

ETSI EN 301 785 V1.1.1 (2001-04)

European Standard (Telecommunications series)

**Fixed Radio Systems;
Point-to-point equipment;
Parameters for packet data radio systems
for transmission of digital signals operating
in the frequency range 23, 26, 28 or 38 GHz**



Reference

DENTM-04092a

Keywords

digital, DRRS, point-to-point, radio, transmission

ETSI

650 Route des Lucioles
F-06921 Sophia Antipolis Cedex - FRANCE

Tel.: +33 4 92 94 42 00 Fax: +33 4 93 65 47 16

Siret N° 348 623 562 00017 - NAF 742 C
Association à but non lucratif enregistrée à la
Sous-Préfecture de Grasse (06) N° 7803/88

Important notice

Individual copies of the present document can be downloaded from:

<http://www.etsi.org>

The present document may be made available in more than one electronic version or in print. In any case of existing or perceived difference in contents between such versions, the reference version is the Portable Document Format (PDF). In case of dispute, the reference shall be the printing on ETSI printers of the PDF version kept on a specific network drive within ETSI Secretariat.

Users of the present document should be aware that the document may be subject to revision or change of status. Information on the current status of this and other ETSI documents is available at <http://www.etsi.org/tb/status/>

If you find errors in the present document, send your comment to:
editor@etsi.fr

Copyright Notification

No part may be reproduced except as authorized by written permission.
The copyright and the foregoing restriction extend to reproduction in all media.

© European Telecommunications Standards Institute 2001.
All rights reserved.

Contents

| | |
|--|----|
| Intellectual Property Rights | 5 |
| Foreword | 5 |
| 1 Scope..... | 6 |
| 2 References | 7 |
| 3 Symbols and abbreviations..... | 8 |
| 3.1 Symbols | 8 |
| 3.2 Abbreviations..... | 9 |
| 4 General characteristics | 9 |
| 4.1 Channel arrangements | 9 |
| 4.2 Channel Spacing..... | 10 |
| 4.3 Compatibility requirements between systems | 10 |
| 4.4 Performance and availability requirements..... | 10 |
| 4.5 Environmental conditions | 10 |
| 4.5.1 Equipment within weather protected locations (indoor locations)..... | 10 |
| 4.5.2 Equipment for non-weather protected locations (outdoor locations)..... | 11 |
| 4.6 Power supply..... | 11 |
| 4.7 Electromagnetic compatibility | 11 |
| 4.8 System block diagram | 11 |
| 4.9 Management Interface | 11 |
| 4.10 Branching/feeder/antenna characteristics..... | 11 |
| 4.10.1 Antenna radiation patterns..... | 11 |
| 4.10.2 Antenna cross-Polar Discrimination (XPD) | 11 |
| 4.10.3 Antenna Inter-Port Isolation (IPI) | 12 |
| 4.10.4 Waveguide flanges (or other connectors)..... | 12 |
| 4.10.5 Return loss..... | 12 |
| 5 System Parameters..... | 12 |
| 5.1 Transmission capacity | 12 |
| 5.2 Data Interface parameters | 12 |
| 5.2.1 Ethernet Data interface..... | 12 |
| 5.3 Transmitter characteristics | 12 |
| 5.3.1 Transmitter power range | 13 |
| 5.3.2 Transmit power and frequency control..... | 13 |
| 5.3.2.1 Automatic Transmit Power Control (ATPC)..... | 13 |
| 5.3.2.2 Remote Transmit Power Control (RTPC) | 13 |
| 5.3.2.3 Remote Frequency Control (RFC)..... | 13 |
| 5.3.3 Transmitter output power tolerance | 14 |
| 5.3.4 Transmit Local Oscillator (LO) frequency arrangements..... | 14 |
| 5.3.5 RF spectrum mask..... | 14 |
| 5.3.6 Discrete CW lines exceeding the spectrum mask limit | 16 |
| 5.3.6.1 Spectral lines at the symbol rate | 16 |
| 5.3.6.2 Other spectral lines | 16 |
| 5.3.7 Spurious emissions..... | 17 |
| 5.3.7.1 Spurious emissions - external..... | 17 |
| 5.3.7.2 Spurious emissions - internal | 17 |
| 5.3.8 Radio frequency tolerance | 17 |
| 5.4 Receiver characteristics | 17 |
| 5.4.1 Input level range | 17 |
| 5.4.2 Receiver local oscillator frequency arrangements..... | 17 |
| 5.4.3 Spurious emissions..... | 17 |
| 5.5 System performance without diversity | 18 |
| 5.5.1 FER as a function of Receiver input Signal Level (RSL)..... | 18 |
| 5.5.2 Equipment Residual FER | 19 |
| 5.5.3 Interference sensitivity | 19 |

| | | |
|--|---|-----------|
| 5.5.3.1 | Co-channel interference sensitivity..... | 19 |
| 5.5.3.2 | Adjacent channel Interference..... | 20 |
| 5.5.3.3 | CW Spurious Interference..... | 20 |
| 5.5.3.4 | Front-end non-linearity requirements (two-tone CW spurious interference)..... | 20 |
| 5.5.4 | Distortion sensitivity..... | 20 |
| 5.6 | System characteristics with diversity..... | 21 |
| Annex A (informative): Additional information | | 22 |
| A.1 | Feeder/antenna return loss..... | 22 |
| A.2 | Automatic Transmit Power Control (ATPC) | 22 |
| A.3 | Co-channel and adjacent channel interference | 23 |
| A.4 | RFER | 25 |
| Annex B (normative): System type codes for regulatory procedures | | 26 |
| Annex C (informative): FER/BER equivalence and FER performance measurement equipment settings (example) | | 27 |
| C.1 | FER/BER equivalence | 27 |
| C.2 | FER equipment settings and measurement techniques (example)..... | 27 |
| History | | 28 |

Intellectual Property Rights

IPRs essential or potentially essential to the present document may have been declared to ETSI. The information pertaining to these essential IPRs, if any, is publicly available for **ETSI members and non-members**, and can be found in ETSI SR 000 314: "*Intellectual Property Rights (IPRs); Essential, or potentially Essential, IPRs notified to ETSI in respect of ETSI standards*", which is available from the ETSI Secretariat. Latest updates are available on the ETSI Web server (<http://www.etsi.org/ipr>).

Pursuant to the ETSI IPR Policy, no investigation, including IPR searches, has been carried out by ETSI. No guarantee can be given as to the existence of other IPRs not referenced in ETSI SR 000 314 (or the updates on the ETSI Web server) which are, or may be, or may become, essential to the present document.

Foreword

This European Standard (Telecommunications series) has been produced by ETSI Technical Committee Transmission and Multiplexing (TM).

The present document has already been published as an ETSI Technical Specification, under TS 101 785.

| National transposition dates | |
|--|-----------------|
| Date of adoption of this EN: | 13 April 2001 |
| Date of latest announcement of this EN (doa): | 31 July 2001 |
| Date of latest publication of new National Standard or endorsement of this EN (dop/e): | 31 January 2002 |
| Date of withdrawal of any conflicting National Standard (dow): | 31 January 2002 |

1 Scope

The present document specifies the minimum performance parameters for terrestrial fixed packet data service radio communications equipments operating at 23, 26, 28, or 38 GHz. Such digital systems are intended to be used for point-to-point connections in local and regional networks at data rates of 10 Mbit/s and 100 Mbit/s and operate in full-duplex mode.

The parameters to be specified fall into two categories:

- a) those that are required to provide compatibility between channels from different sources of equipment on the same route, connected either:
 - to separate antennas; or
 - to separate polarizations of the same antenna;
- b) parameters defining the transmission quality of the proposed system.

The present document deals with Radio Frequency (RF) and baseband characteristics relevant to packet data networking equipment. Antenna/feeder system requirements are covered in EN 300 833 [2].

The present document does not focus on aspects related to test procedures and test conditions, however they are to be found in EN 301 126-1 [1], IEEE 1802.3 [15], and IEEE 1802.3d [16].

As the maximum transmission rate in a given bandwidth depends on system spectral efficiency, different equipment classes are defined:

- | | |
|----------|--|
| Class 2: | equipment spectral efficiency based on typically 4-states modulation scheme (e.g. 4-FSK, 4-QAM, or equivalent); |
| Class 4: | equipment spectral efficiency based on typically 16 or 32-states modulation scheme (e.g. 16-QAM, 32-QAM, or equivalent); |
| Class 5: | equipment spectral efficiency based on typically 64 or 128-states modulation scheme (e.g. 64-QAM, 128-QAM, or equivalent). |

The above classes are indicative only and do not imply any constraint to the actual modulation format, provided that all the requirements in the present document are met.

Safety aspects are outside the mandate of ETSI and they will not be considered in the present document. However compliance to EN 60950 [22] will be required to comply with 1999/5/EC [24] Directive (R&TTE).

Technical background for most of the parameters and requirements referred in the present document may be found in TR 101 036-1 [11] and IEEE 802.3 [14].

The present document does not address SDH/PDH radio requirements, therefore equipment with SDH/PDH interfaces should meet the requirements of the appropriate SDH/PDH radio specifications.

2 References

The following documents contain provisions which, through reference in this text, constitute provisions of the present document.

- References are either specific (identified by date of publication, edition number, version number, etc.) or non-specific.
- For a specific reference, subsequent revisions do not apply.
- For a non-specific reference, the latest version applies.

- [1] ETSI EN 301 126-1: "Fixed Radio Systems; Conformance testing; Part 1: Point-to-Point equipment - Definitions, general requirements and test procedures".
- [2] ETSI EN 300 833: "Fixed Radio Systems; Point-to-Point Antennas; Antennas for point-to-point fixed radio systems operating in the frequency band 3 GHz to 60 GHz".
- [3] ETSI ETS 300 019: "Equipment Engineering (EE); Environmental conditions and environmental tests for telecommunications equipment".
- [4] ETSI ETS 300 132-1: "Equipment Engineering (EE); Power supply interface at the input to telecommunications equipment; Part 1: Operated by alternating current (ac) derived from direct current (dc) sources".
- [5] ETSI ETS 300 132-2: "Equipment Engineering (EE); Power supply interface at the input to telecommunications equipment; Part 2: Operated by direct current (dc)".
- [6] ETSI EN 300 385: "Electromagnetic compatibility and Radio spectrum Matters (ERM); ElectroMagnetic Compatibility (EMC) standard for fixed radio links and ancillary equipment".
- [7] ITU-R Recommendation F.1102: "Characteristics of radio-relay systems operating in frequency bands above about 17 GHz".
- [8] ITU-R Recommendation F.1191-1: "Bandwidths and unwanted emissions of digital radio-relay systems".
- [9] ITU-R Recommendation P.530-8: "Propagation data and prediction methods required for the design of terrestrial line-of-sight systems".
- [10] IEC 60154-2: "Flanges for waveguides. Part 2: Relevant specifications for flanges for ordinary rectangular waveguides".
- [11] ETSI TR 101 036-1 (V1.1.2): "Transmission and Multiplexing (TM); Digital Radio Relay Systems (DRRS); Generic wordings for standards on DRRS characteristics; Part 1: General aspects and point-to-point equipment parameters".
- [12] IEC 60153-2: "Hollow metallic waveguides. Part 2: Relevant specifications for ordinary rectangular waveguides".
- [13] CEPT/ERC Recommendation 74-01: "Spurious emissions".
- [14] IEEE 802.3 (1998): "Information technology - Telecommunications and information exchange between systems - Local and metropolitan area networks - Specific requirements - Part 3: Carrier sense multiple access with collision detection (CSMA/CD) access method and physical layer specifications".
- [15] IEEE 1802.3 (1991): "Conformance Test Methodology for IEEE Standards for Local and Metropolitan Area Networks: Carrier Sense Multiple Access with Collision Detection (CSMA/CD) Access Method and Physical Layer Specifications: Currently Contains Attachment Unit Interface (AUI) Cable (Section 4)".
- [16] IEEE 1802.3d (1993): "Supplement to IEEE Std 1802.3-1991, Type 10BASE-T Medium Attachment Unit (MAU) Conformance Test Methodology (Section 6)".

- [17] CEPT Recommendation T/R 12-01: "Harmonized radio frequency channel arrangements for analogue and digital terrestrial fixed systems operating in the band 37-39,5 GHz".
- [18] CEPT Recommendation T/R 13-02E: "Preferred channel arrangements for fixed services in the range 22,0-29,5 GHz".
- [19] ITU-R Recommendation F.748-3: "Radio-frequency channel arrangements for radio-relay systems operating in the 25, 26 and 28 GHz bands".
- [20] ITU-R Recommendation F.637-3: "Radio-frequency channel arrangements for radio-relay systems operating in the 23 GHz band".
- [21] IEEE 802.1Q (1998): "IEEE Standard for Local and Metropolitan Area Networks: Virtual Bridged Local Area Networks".
- [22] EN 60950: "Safety of information technology equipment".
- [23] Council Directive 89/336/EEC of 3 May 1989 on the approximation of the laws of the Member States relating to electromagnetic compatibility.
- [24] Directive 1999/5/EC of the European Parliament and of the Council of 9 March 1999 on radio equipment and telecommunications terminal equipment and the mutual recognition of their conformity.
- [25] ETSI EN 301 489-4: "Electromagnetic compatibility and Radio spectrum Matters (ERM); ElectroMagnetic Compatibility (EMC) standard for radio equipment and services; Part 4: Specific conditions for fixed radio links and ancillary equipment and services".

3 Symbols and abbreviations

3.1 Symbols

For the purposes of the present document, the following symbols apply:

| | |
|-----------------|---|
| dB | deciBel |
| dBc | deciBel relative to mean carrier power |
| dB _i | deciBel relative to an isotropic radiator |
| dB _m | deciBel relative to 1 milliWatt |
| dBW | deciBel relative to 1 Watt |
| GHz | GigaHertz |
| kHz | kiloHertz |
| Mbit/s | Mega-bits per second |
| MHz | MegaHertz |
| ppm | parts per million |

3.2 Abbreviations

For the purposes of the present document, the following abbreviations apply:

| | |
|-------|--|
| ac | alternating current |
| ATPC | Automatic Transmit Power Control |
| BER | Bit Error Ratio |
| C/I | Carrier to Interference ratio |
| CSmin | minimum practical channel separation (for a given radio-frequency channel arrangement) |
| CW | Continuous Wave |
| dc | direct current |
| DRRS | Digital Radio Relay Systems |
| EMC | ElectroMagnetic Compatibility |
| FER | Frame Error Ratio |
| FSK | Frequency-Shift Keying (modulation) |
| IF | Intermediate Frequency |
| IPI | Inter-Port Isolation |
| LO | Local Oscillator |
| QAM | Quadrature Amplitude Modulation |
| RF | Radio Frequency |
| RFC | Remote Frequency Control |
| RFER | Residual FER |
| RSL | Receive Signal Level |
| RTPC | Remote Transmit Power Control |
| XPD | cross-Polar Discrimination |

4 General characteristics

4.1 Channel arrangements

The equipment shall operate on one or more of the channels as defined below:

The frequency range shall be 22,0 GHz to 22,6 GHz paired with 23 GHz to 23,6 GHz The channel arrangements shall be in accordance with CEPT Recommendation T/R 13-02E [18].

NOTE: In a transition period for the adoption of CEPT Recommendation T/R 13-02E [18], different plans, derived by ITU-R Recommendation F.637-3 [20], may be required on national basis.

The frequency range shall be 24, 50 GHz to 29,50 GHz. The channel arrangements shall be in accordance with CEPT Recommendation T/R 13-02E [18] or ITU-R Recommendation F.748-3 [19].

The frequency range shall be 37,0 GHz to 39,5 GHz. The channel arrangements shall be in accordance with CEPT Recommendation T/R 12-01 [17].

4.2 Channel Spacing

System bit rates and their relevant channel spacing in the present document are reported in table 1 (for the precise payload bit rates, see clause 5.1).

NOTE: According to systems characteristics the equipment can be connected either to separate antennas or on a separate polarization to the same antenna.

Table 1: Digital systems channel spacing for various bit rates

| Channel Spacing [MHz] | Payload Bit Rate [Mbit/s]⇒ | 10 | 100 |
|-----------------------|----------------------------|--------------------|-------|
| | | Class 2 equipments | 7 |
| | Class 4 equipments | 3,5 | 56/28 |
| | Class 5 equipments | | 28 |

For regulatory purposes in national procedures for licensing radio equipments according to the present document, the above system types shall be identified by the "system type codes" reported in normative annex B.

4.3 Compatibility requirements between systems

The compatibility requirements between systems are as follows:

- there shall be no requirement to operate transmitting equipment from one manufacturer with receiving equipment from another;
- there shall not be a requirement to multiplex different manufacturers equipment on the same antenna;
- depending on the application, it shall be possible to operate the system in vertical and/or horizontal polarization, if required by the channel arrangement.

4.4 Performance and availability requirements

The requirements for digital equipment defined in clause 5 of the present document are intended to meet the network performance requirements defined by IEEE for 10 Mbit/s and 100 Mbit/s Ethernet networks. The implication of the link design on the performance is recognized and the general design criteria reported in ITU-R Recommendations P.530-8 [9] and F.1102 [7] shall be applied. Performance requirements for public networks are under study by the ITU-T.

All performance measurements shall be done with 64 octet frames.

4.5 Environmental conditions

The equipment shall be required to meet the environmental conditions set out in ETS 300 019 [3] which defines weather protected and non-weather protected locations, classes and test severity.

The manufacturer shall state which class the equipment is designed to withstand.

4.5.1 Equipment within weather protected locations (indoor locations)

Equipment intended for operation within temperature controlled locations or partially temperature controlled locations shall meet the requirements of ETS 300 019 [3] classes 3.1 and 3.2 respectively.

Optionally, the more stringent requirements of ETS 300 019 [3] classes 3.3 (non-temperature controlled locations), 3.4 (sites with heat trap) and 3.5 (sheltered locations) may be applied.

4.5.2 Equipment for non-weather protected locations (outdoor locations)

Equipment intended for operation within non-weather-protected locations shall meet the requirements of ETS 300 019 [3], class 4.1 or 4.1E.

Class 4.1 applies to many European countries and class 4.1E applies to all European countries.

4.6 Power supply

The power supply interface shall be in accordance with the characteristics of one or more of the secondary voltages foreseen in ETS 300 132-1 [4] and ETS 300 132-2 [5].

NOTE: Some applications may require secondary voltages that are not covered by ETS 300 132-1 [4] and ETS 300 132-2 [5].

4.7 Electromagnetic compatibility

Equipment shall operate under the conditions specified in EN 300 385 [6] or EN 301 489-4 [25].

4.8 System block diagram

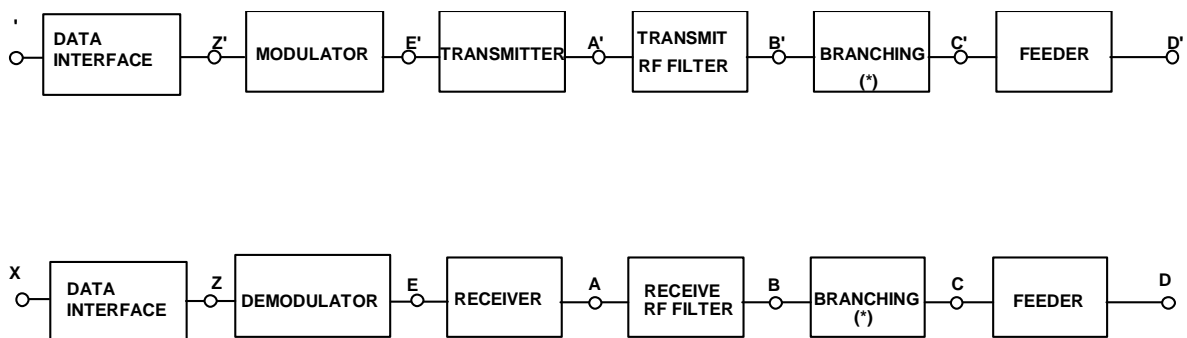

NOTE 1: For the purpose of defining the measurement points, the branching network does not include a hybrid.

NOTE 2: The points shown above are reference points only; points C and C', D and D' in general coincide.

NOTE 3: Points B and C, B' and C' may coincide when simple duplexer is used.

Figure 1: System block diagram

4.9 Management Interface

There is no specific requirement for the management interface.

4.10 Branching/feeder/antenna characteristics

4.10.1 Antenna radiation patterns

See EN 300 833 [2].

4.10.2 Antenna cross-Polar Discrimination (XPD)

See EN 300 833 [2].

4.10.3 Antenna Inter-Port Isolation (IPI)

See EN 300 833 [2].

4.10.4 Waveguide flanges (or other connectors)

When flanges are required at reference point C, C', the following shall be used according to IEC 60154-2 [10]:

- UBR/PBR/CBR 260, for the complete 26/28 GHz frequency range;
- UBR/PBR/CBR 220, for the complete 23 GHz frequency range and the lower part of the 26/28 GHz frequency range (The upper frequency limit for waveguide R 220 is 26,50 GHz, according to IEC 60153-2 [12]);
- UBR/PBR/CBR 320, for the complete 38 GHz frequency range and the higher part of the 26/28 GHz frequency range (The lower frequency limit for waveguide R 320 is 26,50 GHz, according to IEC 60153-2 [12]).

4.10.5 Return loss

Equipment according to the present document are likely to have integral antennas or very similar technical solutions, without long feeder connections; return loss is not considered an essential requirement. When an antenna is an integral part of the equipment there shall be no requirement.

For feeder/antenna return loss requirement see clause A.1.

5 System Parameters

5.1 Transmission capacity

Data Interface bit rates at points X and X' considered in the present document are:

- 10 Mbit/s; and
- 100 Mbit/s.

In the following clauses, these capacities will be simply referred as 10 Mbit/s and 100 Mbit/s.

5.2 Data Interface parameters

All of the following specified data interface parameters refer to point X and X' of figure 1. Parameters for service channels and wayside traffic channels are outside the scope of the present document.

FER/BER equivalence explanation for all parameters is given in clause C.1.

5.2.1 Ethernet Data interface

10 Mbit/s and 100 Mbit/s interfaces shall comply with the OSI physical layer requirements for Medium Dependent Interfaces defined in IEEE 802.3 [14]. 10 Mbit/s and 100 Mbit/s interfaces shall comply with the maximum packet sizes defined in IEEE 802.1Q [21].

5.3 Transmitter characteristics

The specified transmitter characteristics shall be met with the appropriate baseband signals applied at reference point X' of figure 1. The Ethernet interface shall be a test signal according to IEEE 1802.3 [15] and IEEE 1802.3d [16].

5.3.1 Transmitter power range

Transmitter maximum mean output power at reference point C' of the system block diagram (figure 1) shall not exceed +30 dBm (including tolerance and, if applicable, ATPC/RTPC influence).

Regulatory administrations may define nominal sub-ranges below this maximum limit.

NOTE: The technological evolution may result in equipment falling outside of the range(s) foreseen in this clause. In this case the equipments of different output power sub-ranges are not considered to require individual type approval, however their use is subject to individual national agreements.

A capability for output power level adjustment may be required for regulatory purposes, in which case the range of adjustment, either by fixed or automatic attenuators, should be in steps of 5 dB or less.

5.3.2 Transmit power and frequency control

5.3.2.1 Automatic Transmit Power Control (ATPC)

ATPC is an optional feature. Equipment with ATPC will be subject to manufacturer declaration of ATPC ranges and related tolerances. The manufacturer shall declare if the equipment is designed with ATPC as a fixed permanent feature. Testing shall be carried out with output power level corresponding to:

- ATPC set manually to a fixed value for system performance (clauses 5.5 and 5.6);
- ATPC set at maximum available power for transmit performance (clause 5.3).

It shall be verified that the emitted RF spectrum is within the absolute RF spectrum mask evaluated for the maximum available output power of the equipment, including attenuation introduced by RTPC, if any.

Where the use of ATPC is considered compulsory for regulatory purposes the transmitter output shall meet the spectrum mask limits throughout the ATPC range.

5.3.2.2 Remote Transmit Power Control (RTPC)

RTPC is an optional feature. Equipment with RTPC will be subject to manufacturer declaration of RTPC ranges and related tolerances. Testing shall be carried out with output power level corresponding to:

- RTPC set to the maximum nominal power for transmit performance (clause 5.3) and for system performance (clause 5.5 and 5.6);
- the RF spectrum mask shall be verified in three points (low, medium, and high) of the RTPC power excursion and with ATPC set to maximum available power (if any). When these spectrum measurements are made difficulties may be experienced. Actual measurement methods shall be addressed in further investigations and will be defined in the conformance testing standard, EN 301 126-1 [1].

RTPC range should be restricted, taking into account the wideband noise generated by the transmitter chain, to ensure the spectrum mask requirements are met throughout the transmitter output power range.

Where the use of ATPC is considered compulsory for regulatory purposes the transmitter output shall meet the spectrum mask limits throughout the ATPC range.

5.3.2.3 Remote Frequency Control (RFC)

RFC is an optional feature. Equipment with RFC will be subject to manufacturer declaration of RFC ranges and related change frequency procedure. Testing shall be carried out including:

- RFC setting procedure at least for three frequencies (lower, centre and higher of the covered range);
- RFC setting procedure shall not produce emissions outside the previous and final frequency spectrum mask.

5.3.3 Transmitter output power tolerance

The nominal output power shall be declared by the supplier.

The tolerance of the nominal output power shall be within:

- nominal output power ± 2 dB: for classes 3.1 and 3.2 as defined by ETS 300 019 [3];
- nominal output power ± 2 dB (± 3 dB for 38 GHz): for classes 3, 4 and 5 systems operating within non-weather protected locations and within classes 3.3, 3.4 and 3.5 weather protected locations as defined by ETS 300 019 [3].

5.3.4 Transmit Local Oscillator (LO) frequency arrangements

There shall be no requirement on LO frequency arrangement.

5.3.5 RF spectrum mask

The spectrum masks are shown in figures 2a and 2b.

The 0 dB level shown on the spectrum masks relates to the spectral power density of the nominal centre frequency disregarding residual carrier.

The recommended spectrum analyser settings for measuring the RF spectrum mask detailed in figures 2a and 2b are shown in the table 2:

Table 2: Spectrum analyser settings for RF power spectrum measurement

| Channel Spacing [MHz] | 3,5 | 7 | 28 | 56 |
|-----------------------|------|------|------|------|
| Sweep width [MHz] | 20 | 40 | 160 | 320 |
| Scan time | Auto | Auto | Auto | Auto |
| IF bandwidth [kHz] | 30 | 30 | 100 | 100 |
| Video bandwidth [kHz] | 0,1 | 0,3 | 0,3 | 0,3 |

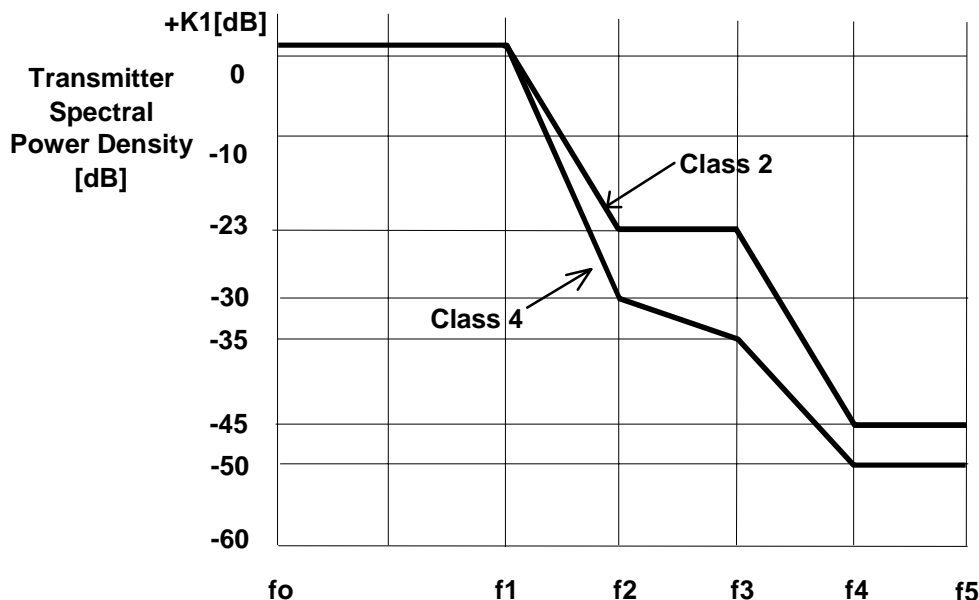

NOTE: Frequency from actual transmitter centre frequency [MHz].

Figure 2a: Limits of spectral power density for class 2 and 4 systems

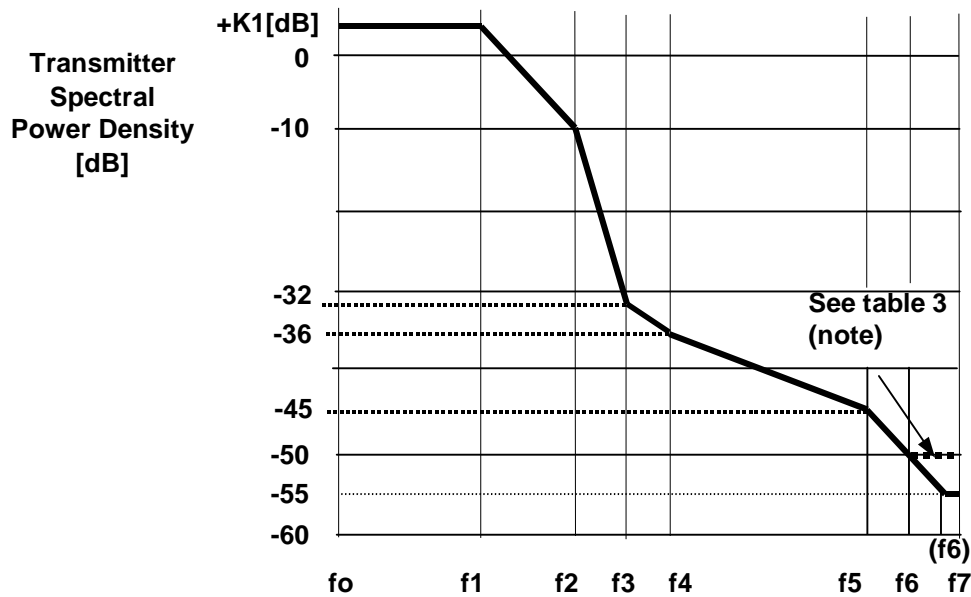

NOTE: Frequency from actual transmitter centre frequency [MHz].

Figure 2b: Limits of spectral power density for Class 5 systems

Due to limitations of some spectrum analysers, difficulties may be experienced when testing high capacity/wideband systems. In this event, the following options are to be considered: measurement using high performance spectrum analyser, use of notch filters and two-step measurement technique. Where difficulties are experienced, the plots of one test conducted at ambient and environmental extremes may be produced as evidence to conformance to the spectrum mask.

Reference frequencies f_1 to f_7 and relative attenuation K_1 [dB] are reported in table 3 for the bit rate and channel spacing foreseen:

Table 3: Spectrum mask frequency limits

| Spectrum efficiency class | Bit-rate [Mbit/s] | Channel spacing [MHz] | Figure | K_1 [dB] | f_1 [MHz] | f_2 [MHz] | f_3 [MHz] | f_4 [MHz] | f_5 [MHz] | f_6 [MHz] | f_7 [MHz] |
|---------------------------|-------------------|-----------------------|--------|------------|-------------|-------------|-------------|-------------|-------------|-------------|-------------|
| 2 | 10 | 7 | 2a | +1 | 2,8 | 5,6 | 7 | 14 | 17,5 | n.a. | n.a. |
| 4 | 10 | 3,5 | 2a | +1 | 1,4 | 2,8 | 3,5 | 6,15 | 8,75 | n.a. | n.a. |
| | 100 | 56 | 2a | +1 | 22,5 | 33 | 65 | 74 | 140 | n.a. | n.a. |
| 5 | 100 | 28 | 2a | +1 | 11,3 | 16,5 | 32,5 | 37 | 70 | n.a. | n.a. |
| | 100 | 28 | 2b | +2 | 12 | 14,5 | 15,5 | 17 | 25 | 30 | 70 |

n.a.: not applicable

NOTE: The mask floor at 55 dB is required for guaranteeing RFER performance in the presence of multiple adjacent channels regardless of the FEC algorithm implemented, however for regulatory purposes attenuation greater than 50 dB is not required. The corresponding f_1 - f_7 values for a mask floor of 50 dB is as follows.

Table 4

| Spectrum efficiency class | Bit-rate [Mbit/s] | Channel spacing [MHz] | Figure | K_1 [dB] | f_1 [MHz] | f_2 [MHz] | f_3 [MHz] | f_4 [MHz] | f_5 [MHz] | f_6 [MHz] | f_7 [MHz] |
|---------------------------|-------------------|-----------------------|--------|------------|-------------|-------------|-------------|-------------|-------------|-------------|-------------|
| 5 | 100 | 28 | 2b | +2 | 12 | 14,5 | 15,5 | 17 | 25 | 27,5 | 70 |

5.3.6 Discrete CW lines exceeding the spectrum mask limit

5.3.6.1 Spectral lines at the symbol rate

The power level (reference point B') of spectral lines at a distance from the channel centre frequency equal to the symbol rate shall be more than 23 dB below the average power level of the carrier for class 2, 37 dB for class 4 and 43 dB for class 5.

5.3.6.2 Other spectral lines

In case some CW components exceed the spectrum mask, an additional allowance is given.

Those lines shall not:

- exceed the mask by a factor more than $\{10 \log (CS_{min}/IFbw) - 10\}$ dB;
- be spaced each other in frequency by less than CS_{min} .

Where:

$CS_{min} = 1\,750$ kHz for all 23 GHz, 26 GHz, 28 GHz and 38 GHz bands.

IFbw is the recommended resolution IF bandwidth, expressed in kHz, reported in table 2.

Figure 3 shows a typical example of this requirement.

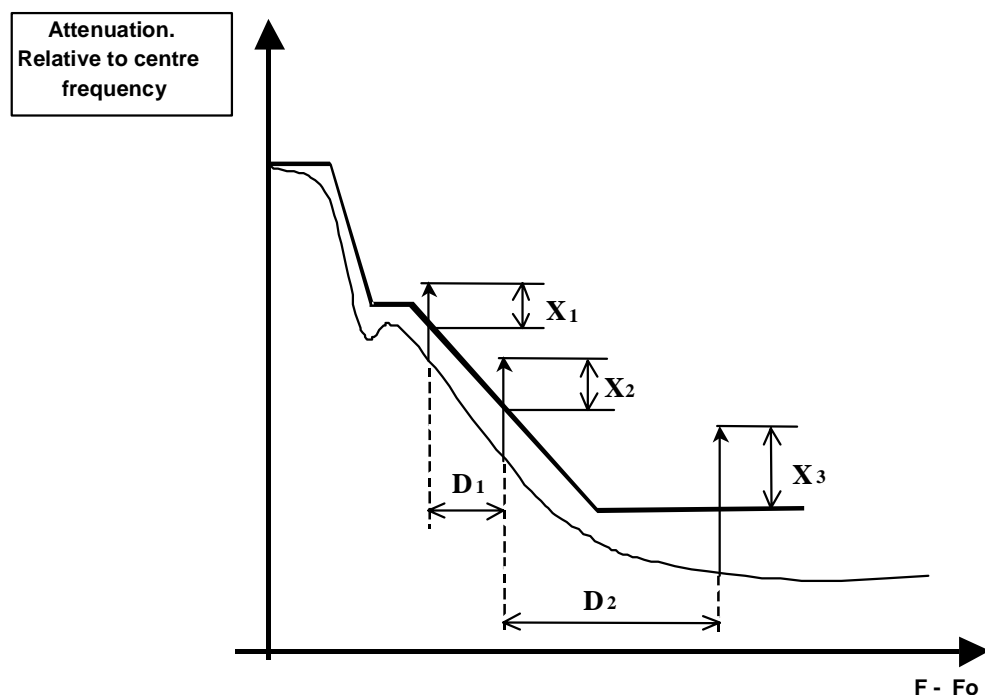

$$X_1, X_2, X_3 \text{ [dB]} \leq 10 \log (CS_{min} / IFbw) - 10$$

$$D_1, D_2 \geq CS_{min}$$

Figure 3: CW lines exceeding the spectrum mask (typical example)

5.3.7 Spurious emissions

It is necessary to define spurious emissions from transmitters for two reasons:

- to limit interference into systems operating wholly externally to the system channel plan (external emissions);
- to limit local interference within the system where transmitters and receivers are directly connected via the filter and branching systems (internal emissions).

This leads to two sets of spurious emission limits where the specific limits given for "internal" interference are required to be no greater than the "external" level limits at reference point B' for indoor systems and C' for outdoor systems (where a common Tx/Rx duplexer is used).

5.3.7.1 Spurious emissions - external

According to ITU-R Recommendation F.1191-1 [8], and CEPT/ERC Recommendation 74-01 [13], the external spurious emissions are defined as emissions at frequencies which are outside the nominal carrier frequency $\pm 250\%$ of the relevant channel separation.

The limits of these emissions shall conform to CEPT/ERC Recommendation 74-01 [13].

5.3.7.2 Spurious emissions - internal

Given that there is no requirement to multiplex equipment of different manufacturers on the same antenna, there is no requirement for internal spurious emissions.

5.3.8 Radio frequency tolerance

Maximum radio frequency tolerance shall not exceed ± 15 ppm. This limit includes both short-term factors (environmental effects) and long-term ageing effects.

In the type test the manufacturer shall state the guaranteed short-term part and the expected ageing part.

5.4 Receiver characteristics

FER/BER equivalence explanation for all parameters is given in clause C.1.

5.4.1 Input level range

The input level range for a FER $< 5 \times 10^{-4}$ shall extend for a minimum of 45 dB above the threshold limit specified for FER = 5×10^{-4} in clause 5.5.1 referenced to point C.

The input level range for a FER $< 5 \times 10^{-6}$ shall extend for a minimum of 41 dB above the threshold limit specified for FER = 5×10^{-6} in clause 5.5.1 referenced to point C.

However an upper limit above -22 dBm is not required for FER = 5×10^{-4} and -24 dBm for FER = 5×10^{-6} .

For equipment designed to operate only with ATPC as a fixed permanent feature, the above maximum input levels are reduced by an amount up to the ATPC range.

5.4.2 Receiver local oscillator frequency arrangements

There shall be no requirement on receiver LO frequency arrangement.

5.4.3 Spurious emissions

The limits of these emissions shall conform to CEPT/ERC Recommendation 74-01 [13].

5.5 System performance without diversity

All parameters are referred to reference point C of figure 2. Losses in RF couplers used for protected systems are not taken into account in the limits specified below.

All measurements shall be carried out with the test signals defined in clause 5.3.

FER/BER equivalence explanation for all parameters is given in clause C.1.

5.5.1 FER as a function of Receiver input Signal Level (RSL)

Receiver FER thresholds (dBm) referred to reference point C of the system block diagram (see figure 1) for a FER of 5×10^{-4} and 5×10^{-6} shall be equal to or lower than those stated in tables 5.1 to 5.3:

Table 5.1: FER performance thresholds for 23 GHz

| Spectrum efficiency class | Bit-rate [Mbit/s] | Channel spacing [MHz] | RSL @ 5×10^{-4} [dBm] | RSL @ 5×10^{-6} [dBm] |
|---------------------------|-------------------|-----------------------|--------------------------------|--------------------------------|
| 2 | 10 | 7 | -79,5 | -77 |
| 4 | 10 | 3,5 | -75,5 | -73 |
| | 100 | 56 | -68,5 | -66 |
| | 100 | 28 | -65,5 | -63 |
| 5 | 100 | 28 | -65 | -63 |

Table 5.2: FER performance thresholds for 26/28 GHz

| Spectrum efficiency class | Bit-rate [Mbit/s] | Channel spacing [MHz] | RSL @ 5×10^{-4} [dBm] | RSL @ 5×10^{-6} [dBm] |
|---------------------------|-------------------|-----------------------|--------------------------------|--------------------------------|
| 2 | 10 | 7 | -78,5 | -76 |
| 4 | 10 | 3,5 | -74,5 | -72 |
| | 100 | 56 | -67,5 | -65 |
| | 100 | 28 | -64,5 | -62 |
| 5 | 100 | 28 | -64 | -62 |

Table 5.3: FER performance thresholds for 38 GHz

| Spectrum efficiency class | Bit-rate [Mbit/s] | Channel spacing [MHz] | RSL @ 5×10^{-4} [dBm] | RSL @ 5×10^{-6} [dBm] |
|---------------------------|-------------------|-----------------------|--------------------------------|--------------------------------|
| 2 | 10 | 7 | -75,5 | -73 |
| 4 | 10 | 3,5 | -71,5 | -69 |
| | 100 | 56 | -64,5 | -62 |
| | 100 | 28 | -61,5 | -59 |
| 5 | 100 | 28 | -61 | -59 |

5.5.2 Equipment Residual FER

The RFER level under simulated operating conditions without interference shall be guaranteed with a signal level at reference point C which is between 10 dB and 35 dB above the level which gives $FER = 5 \times 10^{-4}$ (as specified in clause 5.5.1).

To guarantee a higher degree of service, see informative clause A.4, the network operator may require equipment to meet a RFER limit with the first adjacent channel interferer. In this case the RFER level under simulated operating conditions with interference shall be guaranteed with a signal level at reference point C which is between 15 dB and 35 dB above the level which gives $FER = 5 \times 10^{-4}$ (as specified in clause 5.5.1). The interferer level shall be set to represent a Carrier to Interference ratio (C/I) of -4 dB for all system classes.

The RBER shall be:

- for systems capacity at 10 Mbit/s: RFER < 5×10^{-8} ;
- for systems capacity at 100 Mbit/s: RFER < 5×10^{-10} .

This requirement is intended for the payload bit rates defined in clause 5.1.

EN 301 126-1 [1] recognizes that this requirement is subject to a supplier declaration only. However, in informative clause A.4 some background information relating to the actual test methods and test confidence is given.

5.5.3 Interference sensitivity

All receive signal levels and Carrier to Interference ratio (C/I) measurements are referred to reference point C of the RF system block diagram (see figure 1).

5.5.3.1 Co-channel interference sensitivity

The limits of Co-channel Interference shall be as in table 6, giving maximum C/I values for 1 dB and 3 dB degradation of the 5×10^{-4} FER limits specified in clause 5.5.1.

The Indicative behaviour for these and other values of degradation may be found in figures A.3.1a and A.3.1b.

Table 6: Co-channel interference sensitivity

| co-channel interference | | degradation → | C/I at FER @ 5×10^{-4} RSL degradation | |
|--------------------------------|------------------------|----------------------------|---|----------|
| | | | 1 dB | 3 dB |
| Spectrum efficiency class ↓ | Bit rate [Mbit/s] ↓ | Channel spacing [MHz] ↓ | C/I (dB) | C/I (dB) |
| 2 | 10 | 7 | 23 | 19 |
| 4 | 10 | 3,5 | 30 | 26 |
| | 100 | 56 | 30 | 26 |
| | 100 | 28 | 33 | 29 |
| 5 | 100 | 28 | 37 | 33 |

5.5.3.2 Adjacent channel Interference

The limits of adjacent channel interference shall be as given in table 7 for like modulated signals spaced of 1 channel spacing, giving maximum C/I values for 1 dB and 3 dB degradation of the 5×10^{-4} FER limits specified in clause 5.5.1.

The Indicative behaviour for these and other values of degradation may be found in figure A.3.2.

Table 7: First adjacent channel interference sensitivity

| First adjacent channel interference | | degradation → | C/I at FER @ 5×10^{-4} degradation | |
|-------------------------------------|---------------------|-------------------------|---|----------|
| | | | 1 dB | 3 dB |
| Spectrum efficiency class ↓ | Bit rate [Mbit/s] ↓ | Channel spacing [MHz] ↓ | C/I (dB) | C/I (dB) |
| 2 | 10 | 7 | 0 | -4 |
| 4 | 10 | 3,5 | -1 | -5 |
| | 100 | 56 | -10 | -14 |
| | 100 | 28 | -1 | -5 |
| 5 | 100 | 28 | -8 | -12 |

5.5.3.3 CW Spurious Interference

For a receiver operating at the 5×10^{-4} FER threshold given in table 5, the introduction of a CW interferer at a certain level specified below, with respect to the wanted signal and at any frequency in the range 30 MHz to the second harmonic of the upper frequency band, excluding frequencies either side of the wanted centre frequency of the RF channel by up to 250 % the channel spacing, shall not result in a threshold degradation greater than 1 dB.

The level of the CW interferer shall be:

- for a channel spacing lower than or equal to 14 MHz:
 - +20 dB at any frequency either side of the wanted centre frequency of the RF channel from 250 % up to 500 % the channel spacing;
 - +30 dB outside 500 % the channel spacing;
- for a channel spacing greater than 14 MHz:
 - +30 dB.

NOTE: When waveguide is used between ref. point A and C, which length is higher than twice the free space wavelength of the cut-off frequency (F_c), the lower limit of measurement will be increased to $0,7 F_c$ and to $0,9 F_c$ when the length is higher than 4 times the same wavelength.

This test is designed to identify specific frequencies at which the receiver may have a spurious response, e.g. image frequency, harmonics of the receive filter, etc. The actual test range should be adjusted accordingly. The test is not intended to imply a relaxed specification at all out of band frequencies elsewhere specified in the present document.

5.5.3.4 Front-end non-linearity requirements (two-tone CW spurious interference)

For a receiver operating at the RSL specified in clause 5.5.1 for 5×10^{-4} FER threshold, the introduction of two equal CW interferers each with a level of +19 dB, with respect to the wanted signal and located at the second and fourth adjacent channel in the receive half-band, shall not result in a threshold degradation greater than 1 dB.

5.5.4 Distortion sensitivity

Outage from multi-path phenomena is not considered relevant for the systems subject to the present document.

5.6 System characteristics with diversity

Space diversity receive is not relevant for the systems subject to the present document.

Annex A (informative): Additional information

A.1 Feeder/antenna return loss

When separated antenna and radio equipment are concerned the antenna/feeder system return loss should be considered not less than 20 dB for class 2 systems, 23 dB for class 4 systems and 26 dB for class 5 systems. The measurement should be referred to reference point D/D' of figure 1 towards the antenna.

A.2 Automatic Transmit Power Control (ATPC)

ATPC may be useful in some circumstances, e.g.:

- to reduce interference between neighbouring systems or adjacent channels of the same system;
- to improve compatibility with analogue and digital systems at nodal stations;
- to improve residual FER performance;
- to reduce upfading problems;
- to reduce transmitter power consumption;
- to reduce digital-to-digital and digital to analogue distant interference between hops which re-use the same frequency;
- to increase system gain as a countermeasure against rainfall attenuation.

ATPC as an optional feature is aimed at driving the transmit power amplifier output level from a proper minimum which facilitates the radio network planning requirements and which is used under normal propagation conditions up to a maximum value which fulfils all the specifications defined in the present document.

ATPC may also be used to increase the output power above the nominal level up to the maximum level specified by the manufacturer, with the agreement of administrations and operators, during fading conditions. This can be useful because in frequency ranges above 13 GHz the main limiting factors are given by non-selective fading events.

For planning considerations in a nodal environment a system equipped with ATPC can be considered to operate with its minimum transmitter power.

When ATPC is a fixed feature the ATPC range is defined as the power interval from the maximum (including tolerances) output power level to the lowest transmitter output power level (at reference point B') with ATPC; when it is optional two ranges may be defined, a "down-range" from the nominal level to the minimum (including tolerances) and an "up-range" from the nominal level to the maximum (including tolerances).

A.3 Co-channel and adjacent channel interference

The performances for co-channel and adjacent channel spaced by one channel spacing C/I are reported in clauses 5.5.3.1 and 5.5.3.2 respectively, for 1 dB and 3 dB degradation only; figures A.3.1 and A.3.2 give the indicative behaviour for other values of degradation. The values represented should not be used for frequency co-ordination purposes.

**Receiver Input Level at Reference Point C
relative to FER 5×10^{-4} threshold**

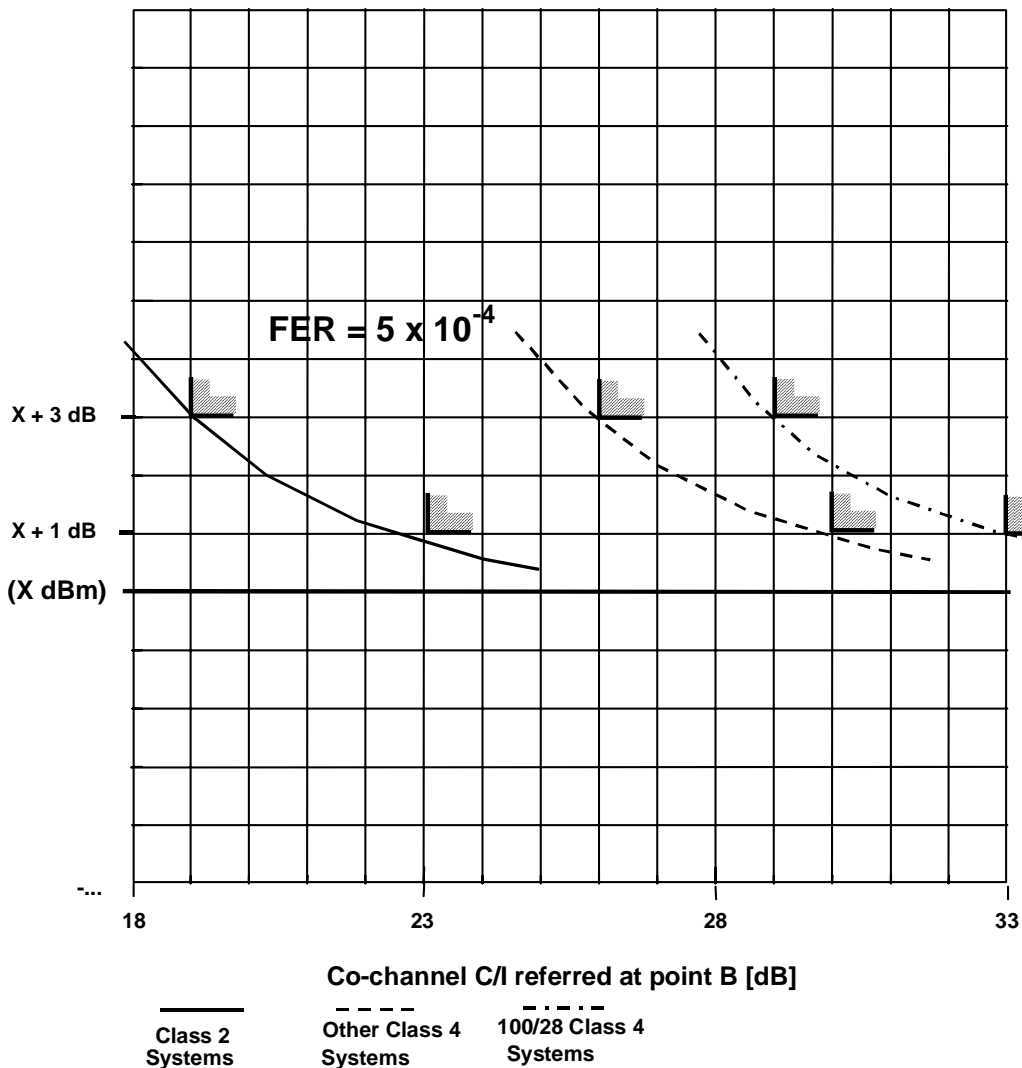

NOTE: X dBm = 5×10^{-4} FER threshold provided by clause 5.5.1.

Figure A.3.1a: Co-channel interference threshold degradation

Receiver Input Level at Reference Point C
relative to FER 5×10^{-4} threshold

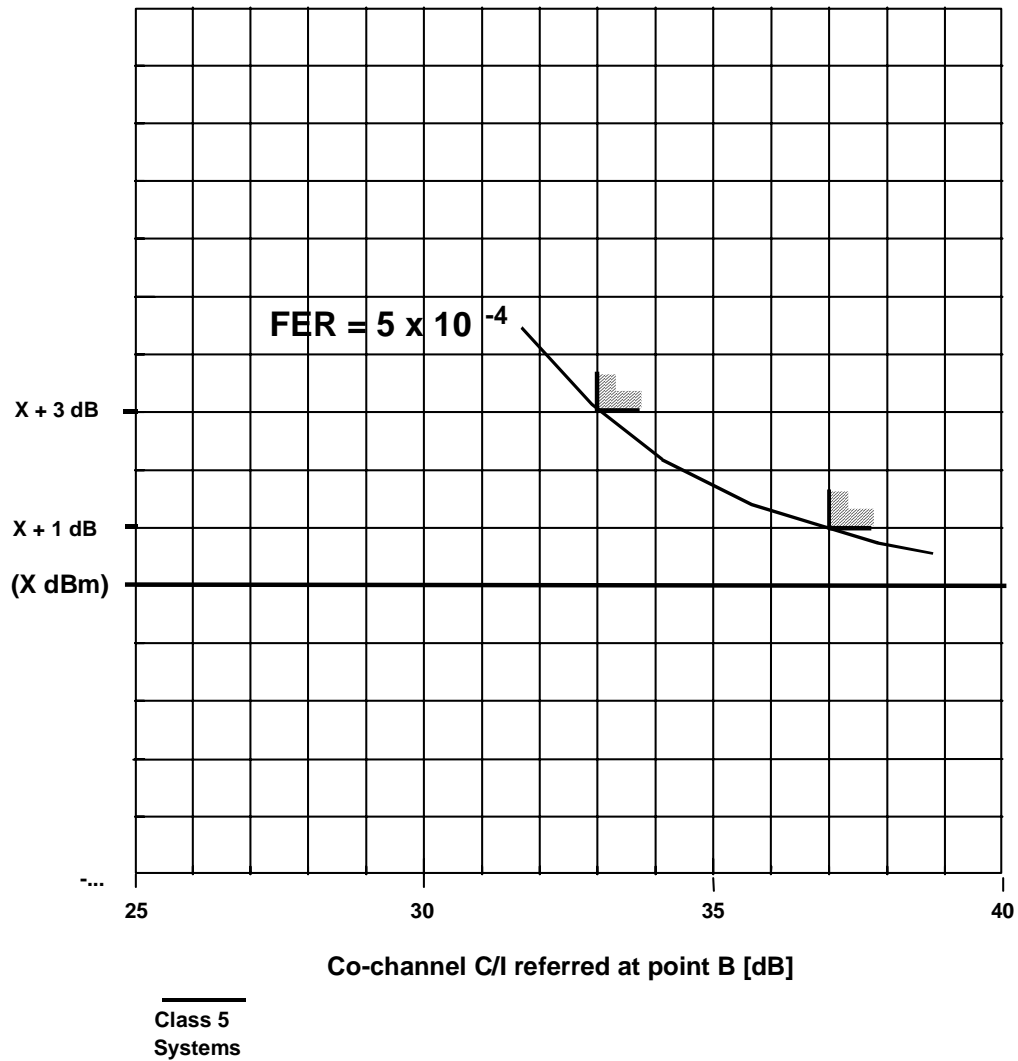

NOTE: X dBm = 5×10^{-4} FER threshold provided by clause 5.5.1.

Figure A.3.1b: Co-channel interference threshold degradation

Receiver Input Level at Reference Point C
relative to FER = 5 x 10⁻⁴ threshold

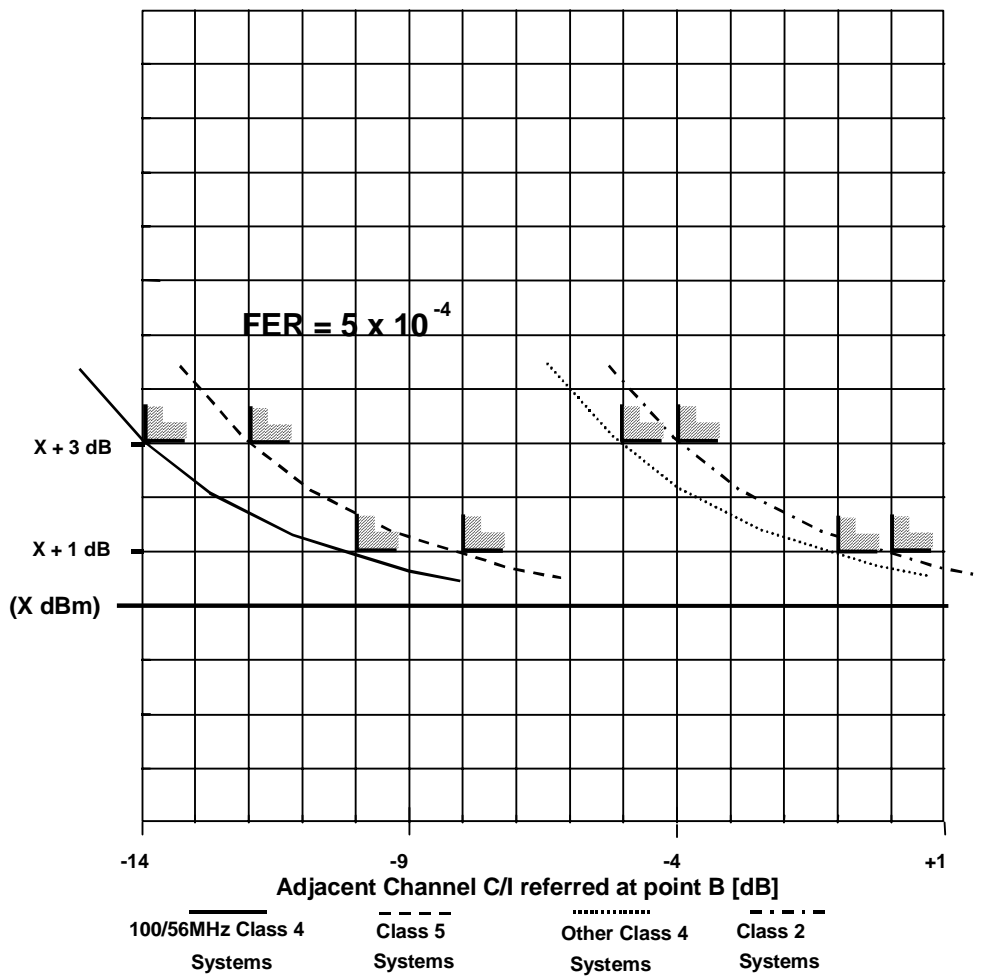

NOTE: X dBm = 5 x 10⁻⁴ FER threshold provided by clause 5.5.1.

Figure A.3.2: First adjacent channel interference threshold degradation

A.4 RFER

In particular applications, where there is a high density of radio links in a specific area, e.g. nodal site, closely located radios may use adjacent channels. Therefore to guarantee the grade of service the equipment will need to meet RFER criteria in the presence of an adjacent channel interferer.

To have sufficient confidence in the measurement, where the FER is relatively low compared to the actual pay load, the test time is very long. The actual background to this measurement and the FER figures are detailed in TR 101 036-1 [11].

When error correction is a fitted feature it may be possible to reduce the measurement time by estimating the RFER using the relevant formula declared by the supplier.

Another option is to ensure that no errors occur during the minimum recording time shown in table A.4.

Table A.4: Zero errors recording times

| Bit-rate under test [Mbit/s] | Minimum recording time [minutes] | errors |
|------------------------------|----------------------------------|--------|
| 10 | 17 | 0 |
| 100 | 160 | 0 |

Annex B (normative): System type codes for regulatory procedures

System types reported in the present document: "Fixed Radio Systems; Point-to-point packet data; Parameters for the transmission of digital signals operating in the 23, 26, 28 or 38 GHz", shall be identified with the codes reported in table B.1.

Table B.1: System type codes for radio equipments reported in the present document, relevant to regulatory procedures for national licensing

| Frequency [GHz] ↓ | Spectrum efficiency class ↓ | Bit-rate [Mbit/s] ↓ | Channel spacing [MHz] ↓ | Frequency Band (note) | System type codes ↓ |
|----------------------|--------------------------------|------------------------|----------------------------|-----------------------|------------------------|
| 23 | 2 | 10 | 7 | n.a. | 01 |
| | 4 | 10 | 3,5 | n.a. | 02 |
| | | 100 | 56 | n.a. | 03 |
| | 5 | 100 | 28 | n.a. | 04 |
| 26 and 28 | 2 | 10 | 7 | B1 | 06 |
| | 4 | 10 | 3,5 | B2 | 07 |
| | | | | B1 | 08 |
| | | 100 | 56 | B2 | 09 |
| | | | | B1 | 10 |
| | 100 | 28 | B1 | 12 | |
| | | | B2 | 13 | |
| | 5 | 100 | 28 | B1 | 14 |
| B2 | 15 | | | | |
| 38 | 2 | 10 | 7 | n.a. | 16 |
| | 4 | 10 | 3,5 | n.a. | 17 |
| | | 100 | 56 | n.a. | 18 |
| | 5 | 100 | 28 | n.a. | 19 |
| 5 | 100 | 28 | n.a. | 20 | |

NOTE 1: Option B1 refers to systems operating in frequency band 24 500 MHz to 26 500 MHz (CEPT Recommendation. T/R 13-02E [18]).

NOTE 2: Option B2 refers to systems operating in frequency band 27 500 MHz to 29 500 MHz (CEPT Recommendation. T/R 13-02E [18], annex B).

Annex C (informative): FER/BER equivalence and FER performance measurement equipment settings (example)

C.1 FER/BER equivalence

FER and BER can be translated as described herein. Ethernet frames can range from 64 octets up to 1 522 octets. We use 64 octet frames for this proposal. An Ethernet frame is considered errored if at least one bit in the frame is errored. Assuming a normal distribution the probability of there being exactly one errored bit in a 64 octet frame is:

$$P = p \times (1 - p)^{64 \times 8 - 1} \times (64 \times 8) \quad \text{where } p = \text{BER}$$

The probability that a frame contains exactly two errors is:

$$P = p^2 \times (1 - p)^{64 \times 8 - 2} \times (64 \times 8)(64 \times 8 - 1)/2$$

From these formulas we can determine the following probabilities and FER:

Table C.1: FER/BER equivalence

| Channel BER | 1 bit error in frame | 2 bit errors in frame | FER |
|---------------------|----------------------|-----------------------|---------------------|
| 1×10^{-6} | 5×10^{-4} | 1×10^{-7} | 5×10^{-4} |
| 1×10^{-8} | 5×10^{-6} | 1×10^{-11} | 5×10^{-6} |
| 1×10^{-10} | 5×10^{-8} | 1×10^{-15} | 5×10^{-8} |
| 1×10^{-12} | 5×10^{-10} | 1×10^{-19} | 5×10^{-10} |

C.2 FER equipment settings and measurement techniques (example)

Equipment used: IEEE 802.3 [14] compliant Ethernet frame test equipment.

The transmitting Ethernet port of the test equipment should be configured to the following settings:

- Mode: Single burst
- Count: 10,000,000 frames
- Length: Fixed, 64 bytes
- Interspaced Gap: 0,96 μ s for 100 Mbit/s, 9,6 μ s for 10 Mbit/s

FER can be calculated by the following formula after using the above measurements:

$$\text{FER} = 1 - (\text{number of non-errored frames received}) / (\text{number of frames transmitted}).$$

For example if 50 frames are lost or errored then the number of non-errored frames indicated by the test equipment will be 9,999,950.

The resulting FER = $1 - 9,999,950 / 10,000,000 = 5 \times 10^{-6}$.

History

| Document history | | |
|-------------------------|----------------|--|
| V1.1.1 | April 2000 | Publication as TS 101 785 |
| V1.1.1 | September 2000 | Public Enquiry PE 20010126: 2000-09-27 to 2001-01-26 |
| V1.1.1 | February 2001 | Vote V 20010413: 2001-02-12 to 2001-04-13 |
| V1.1.1 | April 2001 | Publication |
| | | |