

Draft **ETSI EN 301 783-1** V1.1.1 (2000-03)

European Standard (Telecommunications series)

**Electromagnetic compatibility
and Radio Spectrum Matters (ERM);
Land Mobile Service;
Commercially available amateur radio equipment;
Part 1: Technical characteristics and methods of measurement**



Reference

DEN/ERM-RP02-48-1

Keywords

amateur, EMC, mobile, radio, service

ETSI

Postal address

F-06921 Sophia Antipolis Cedex - FRANCE

Office address

650 Route des Lucioles - Sophia Antipolis
Valbonne - FRANCE
Tel.: +33 4 92 94 42 00 Fax: +33 4 93 65 47 16
Siret N° 348 623 562 00017 - NAF 742 C
Association à but non lucratif enregistrée à la
Sous-Préfecture de Grasse (06) N° 7803/88

Internet

secretariat@etsi.fr
Individual copies of this ETSI deliverable
can be downloaded from
<http://www.etsi.org>
If you find errors in the present document, send your
comment to: editor@etsi.fr

Important notice

This ETSI deliverable may be made available in more than one electronic version or in print. In any case of existing or perceived difference in contents between such versions, the reference version is the Portable Document Format (PDF). In case of dispute, the reference shall be the printing on ETSI printers of the PDF version kept on a specific network drive within ETSI Secretariat.

Copyright Notification

No part may be reproduced except as authorized by written permission.
The copyright and the foregoing restriction extend to reproduction in all media.

© European Telecommunications Standards Institute 2000.
All rights reserved.

Contents

Intellectual Property Rights	4
Foreword	4
Introduction	4
1 Scope	5
2 References	5
3 Definitions, symbols and abbreviations	5
3.1 Definitions.....	5
3.2 Symbols.....	5
3.3 Abbreviations	5
4 Technical requirements specifications	6
4.1 Environmental profile	6
4.2 Conformance requirements	6
4.2.1 Unwanted emissions, conducted.....	6
4.2.1.1 Definition	6
4.2.1.2 Limits	6
4.2.2 Unwanted emissions, radiated	6
4.2.2.1 Definition	6
4.2.2.2 Limits	7
4.2.3 Conducted RF immunity.....	7
4.2.3.1 Definition	7
4.2.3.2 Limits	7
5 Testing for compliance with technical requirements	8
5.1 Environmental conditions for testing	8
5.1.1 EUT test frequencies	8
5.2 Methods of measurement, test sites and general arrangements for measurements involving the use of radiated fields	8
5.2.1 Using the outdoor test site	8
5.2.2 Alternative test site using a fully anechoic RF chamber	9
5.3 Essential radio test suites	9
5.3.1 Unwanted emissions, conducted.....	9
5.3.1.1 Method of measurement	9
5.3.1.2 Limits	10
5.3.2 Unwanted emissions, radiated	10
5.3.2.1 Method of measurement	10
5.3.2.2 Limits	12
5.4 Other test specifications	12
5.4.1 Conducted RF immunity.....	12
5.4.1.1 Method of measurement	12
5.4.1.2 Limits	13
Bibliography	14
History	15

Intellectual Property Rights

IPRs essential or potentially essential to the present document may have been declared to ETSI. The information pertaining to these essential IPRs, if any, is publicly available for **ETSI members and non-members**, and can be found in SR 000 314: *"Intellectual Property Rights (IPRs); Essential, or potentially Essential, IPRs notified to ETSI in respect of ETSI standards"*, which is available from the ETSI Secretariat. Latest updates are available on the ETSI Web server (<http://www.etsi.org/ipr>).

Pursuant to the ETSI IPR Policy, no investigation, including IPR searches, has been carried out by ETSI. No guarantee can be given as to the existence of other IPRs not referenced in SR 000 314 (or the updates on the ETSI Web server) which are, or may be, or may become, essential to the present document.

Foreword

This European Standard (Telecommunications series) has been produced by ETSI Technical Committee Electromagnetic compatibility and Radio spectrum Matters (ERM), and is now submitted for the ETSI standards One-step Approval Procedure.

The present document is part 1 of a multi-part EN covering the Electromagnetic compatibility and Radio Spectrum Matters (ERM); Land Mobile Service; Commercially available amateur radio equipment, as identified below:

Part 1: "Technical characteristics and methods of measurement";

Part 2: "Harmonized EN under article 3.2 of the R&TTE Directive".

The present document has been produced by ETSI in response to a mandate from the European Commission issued under Council Directive 98/34/EC [5] laying down a procedure for the provision of information in the field of technical standards and regulations.

Proposed national transposition dates	
Date of latest announcement of this EN (doa):	3 months after ETSI publication
Date of latest publication of new National Standard or endorsement of this EN (dop/e):	6 months after doa
Date of withdrawal of any conflicting National Standard (dow):	6 months after doa

Introduction

The present document is the "radio product standard" corresponding to commercially available amateur radio equipment.

1 Scope

The present document applies to the following radio equipment types:

- Radio equipment intended to be used by radio amateurs within the meaning of Article 1, definition 53, of the International Telecommunications Union (ITU) Radio Regulations [1] and which is available commercially.

NOTE: It is noted that this sort of equipment is traditionally supplied with an antenna connector.

2 References

The following documents contain provisions which, through reference in this text, constitute provisions of the present document.

- References are either specific (identified by date of publication, edition number, version number, etc.) or non-specific.
- For a specific reference, subsequent revisions do not apply.
- For a non-specific reference, the latest version applies.
- A non-specific reference to an ETS shall also be taken to refer to later versions published as an EN with the same number.

[1] ITU Radio Regulations (Geneva 1994).

[2] ETSI ETS 300 684: "Radio Equipment and Systems (RES); ElectroMagnetic Compatibility (EMC) standard for commercially available amateur radio equipment".

[3] EN 50147 (all parts): "Anechoic chambers".

[4] CISPR 16-1: "Specification for radio disturbance and immunity measuring apparatus and methods - Part 1: Radio disturbance and immunity measuring apparatus".

[5] Directive 98/34/EC of the European Parliament and of the Council of 22 June 1998 laying down a procedure for the provision of information in the field of technical standards and regulations.

3 Definitions, symbols and abbreviations

3.1 Definitions

For the purposes of the present document the definitions in the harmonized standards ETS 300 684 [2] EMC and EN 50147 [3] "Anechoic chambers" as well as the following terms and definitions apply:

Environmental profile: range of environmental conditions under which equipment within the scope of the present document is required to comply with the provisions of the present document.

3.2 Symbols

For the purposes of the present document the symbols in the harmonized standards ETS 300 684 [2] EMC and EN 50147 [3] "Anechoic chambers" apply.

3.3 Abbreviations

For the purposes of the present document the abbreviations in the harmonized standards ETS 300 684 [2] EMC and EN 50147 [3] "Anechoic chambers" apply.

4 Technical requirements specifications

4.1 Environmental profile

The environmental profile for operation of the equipment shall be declared by the supplier. The equipment shall comply with all the technical requirements of the present document at all times when operating within the boundary limits of the required operational environmental profile.

4.2 Conformance requirements

4.2.1 Unwanted emissions, conducted

4.2.1.1 Definition

These are any emissions from the antenna port of the equipment in receive (or transmit standby) mode, or any emission outside of exclusion band defined from the necessary bandwidth in transmit mode.

4.2.1.2 Limits

Table 1: Antenna port limits in transmit mode

Frequency range	Test Limits	Remarks
0,15 MHz to 1,7 MHz	-36 dBm or -60 dBc whichever is higher	
1,7 MHz to 35 MHz	-36 dBm or -40 dBc whichever is higher	
35 MHz to 50 MHz	-40 to -60 dBc or -36 dBm whichever is higher	(note 1)
50 MHz to 1 000 MHz	-36 dBm or -60 dBc whichever is higher	
> 1 000 MHz	-30 dBm or -50 dBc whichever is higher	(note 2)
NOTE 1: The limit in dBc decreases linearly with the logarithm of frequency in the range 35 MHz to 50 MHz.		
NOTE 2: For measurement at frequencies greater than 40 GHz no test limits are specified.		

Where limits are stated using dBc, the reference level is the maximum RF output PEP of the transmitter measured at the antenna port.

Table 2: Antenna port limits in receive or transmit standby mode

Frequency Range	Test Limits	Remarks
0,15 MHz to 1 000 MHz	-57 dBm	
> 1 000 MHz	-47 dBm	(note)
NOTE: For measurement at frequencies greater than 40 GHz no test limits are specified.		

4.2.2 Unwanted emissions, radiated

4.2.2.1 Definition

These are any emissions from the enclosure of the equipment in active, receive (or transmit standby) mode, or any emission outside of exclusion band defined from the necessary bandwidth in transmit mode.

4.2.2.2 Limits

Table 3: Enclosure port limits in active mode

Frequency range	Test limits	Remarks
30 MHz to 35 MHz	-36 dBm or -40 dBc whichever is higher	
35 MHz to 50 MHz	-40 to -60 dBc or -36 dBm whichever is higher	(note 1)
50 MHz to 1 000 MHz	-36 dBm or -60 dBc whichever is higher	
> 1 000 MHz	-30 dBm or -50 dBc whichever is higher	(note 2)
NOTE 1: The limit in dBc decreases linearly with the logarithm of frequency in the range 35 MHz to 50 MHz.		
NOTE 2: For measurement at frequencies greater than 40 GHz no test limits are specified.		

Where limits are stated using dBc, the reference level is the maximum RF output PEP of the transmitter measured at the antenna port.

Table 4: Enclosure port limits in receive or transmit standby mode

Frequency Range	Test Limits	Remarks
30 MHz to 1 000 MHz	-57 dBm	
> 1 000 MHz	-47 dBm	(note)
NOTE: For measurement at frequencies greater than 40 GHz no test limits are specified.		

4.2.3 Conducted RF immunity

4.2.3.1 Definition

This test assesses the ability of receivers, transmitters, transceivers, transverters, RF amplifiers to operate as intended in the presence of a radio frequency conducted disturbance at the receiver antenna port.

This test is applicable to base station, mobile, portable and ancillary equipment.

This test shall not apply to RF low-noise preamplifiers intended for location directly at the antenna.

In normal use, amateur radio transmitting equipment is not collocated with other radio transmitters operating within 10 % of its own carrier frequency, so that inter-transmitter intermodulation will not occur. Therefore immunity testing of the transmitter antenna port is not justified and is not included in the present document.

4.2.3.2 Limits

Table 5: Conducted RF immunity limits

Environmental phenomena	Operating frequency range of EUT	Characteristics of the unwanted signal	Units	Performance criteria
RF conducted immunity	< 30 MHz	90 80 0,15 - 1 000	dB μ V emf % AM (400 Hz) MHz	see subclause 5.3.1
	> 30 MHz	80 80 0,15 - 1 000		See subclause 5.3.1

5 Testing for compliance with technical requirements

5.1 Environmental conditions for testing

5.1.1 EUT test frequencies

Testing shall be performed with the EUT set to frequencies as follows:

- single-band equipment: test at the centre of the band;
- double-band equipment: test at the centre of both bands;
- HF multi-band equipment or VHF/UHF multi-band equipment: test at the centre of the lowest, the centre of the middle, and the centre of the highest band;
- HF/VHF, HF/UHF or HF/VHF/UHF combined equipment: test at the centre of the lowest HF band, the centre of the middle HF band, the centre of the highest HF band, the centre of the lowest VHF/UHF band, the centre of the middle VHF/UHF band, and the centre of the highest VHF/UHF band.

5.2 Methods of measurement, test sites and general arrangements for measurements involving the use of radiated fields

5.2.1 Using the outdoor test site

The outdoor test site shall comply with the requirements of CISPR 16-1 [4]. The standard position for the test sample shall be 1,5 m above the ground plane, supported by a non conductive structure.

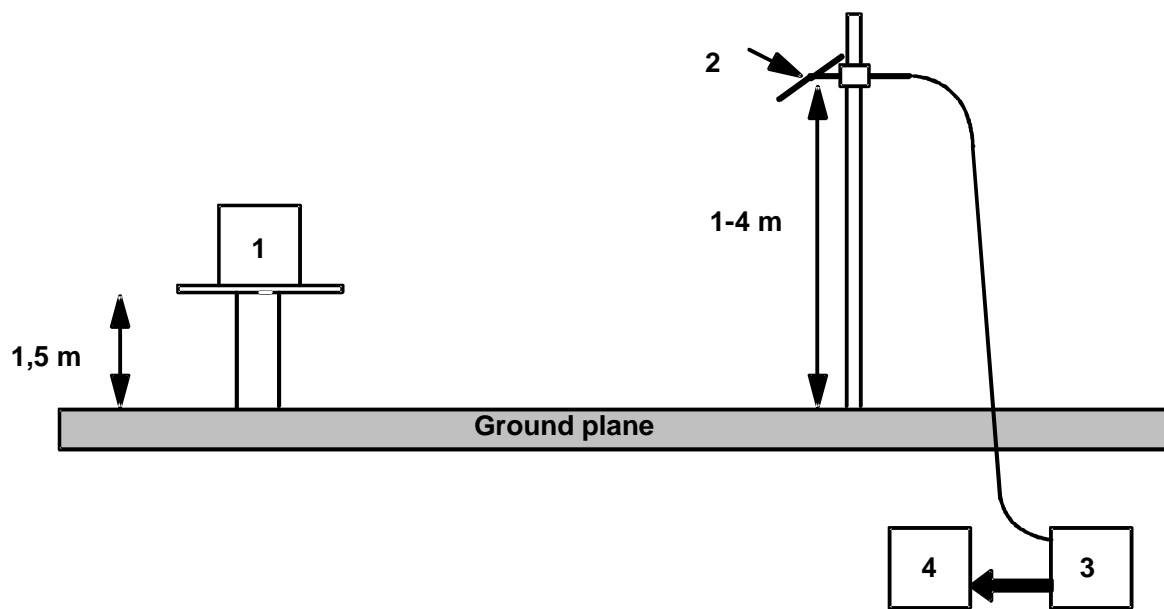

- NOTE:
- 1 Equipment under test.
 - 2 Test antenna.
 - 3 High pass filter (may not be necessary).
 - 4 Spectrum analyser or measuring receiver.

Figure 1: General arrangement

5.2.2 Alternative test site using a fully anechoic RF chamber

Radiated measurements may be performed in a fully anechoic RF chamber simulating a free-space EMC environment. The chamber shall comply with the return loss characteristics of EN 50147 [3]. If such a chamber is used, this fact shall be recorded in the test report.

5.3 Essential radio test suites

5.3.1 Unwanted emissions, conducted

5.3.1.1 Method of measurement

The EUT shall be terminated in a non radiating load and power attenuator according to the manufacturer's specifications. The output of the power attenuator shall be connected to a measuring receiver. The measuring receiver (or spectrum analyser) shall comply with the bandwidth and detector requirements as stated below.

The EUT shall be modulated such that the maximum PEP output is achieved, either by single or multiple tones, or by a suitable bit stream, or in the case of transmitters for other than analogue voice or data, by test modulation representative of normal use. Where thermal limitations prevent continuous transmissions under such conditions, the measurements may be made using gated methods. Under these circumstances, the test method shall be documented in the test report.

The manufacturer shall declare the test modulation. In the case of analogue voice modulation for a Single SideBand (SSB) or Double SideBand Suppressed Carrier (DSB-SC) transmitter, the modulation shall consist of two sinusoidal, non-harmonically related frequencies such as to produce signals of equal output power. In the case of an AM transmitter, one such signal shall be used, with a modulation depth of the rated value. In the case of a narrow band FM transmitter, the modulation shall consist of a single audio frequency of such level that the deviation shall be the rated value as declared by the manufacturer.

In the case of equipment intended for data transmission, the manufacturer shall declare a Test Data Sequence with which the transmitter shall be modulated. The Test Data Sequence shall be such that:

- the generated RF signal is the same for each transmission;
- the transmissions occur regularly in time;
- sequences of transmissions can be repeated accurately;
- the format of the signal is such that the transmitted data (as opposed to any preamble or synchronization sequences) is essentially random in nature;
- the modulation depth (or deviation) attained is representative of the normal intended use of the equipment.

The same Test Data Sequence shall be used for all emissions measurements on the same equipment.

For equipment intended for modulation by signals other than those defined above, the modulation shall be representative of that in normal use. In all cases, the details of the modulation shall be documented in the test report.

The measuring receiver shall be tuned over the measurement frequency range and at each frequency at which a spurious component is detected, the power level shall be recorded as the conducted spurious emission level delivered into the specified load. The measurements shall be repeated with the EUT in standby-mode and with the EUT in receive mode.

The measurement frequency range extends from 150 kHz to 12,5 GHz or $2 \times F_c$ (table 7) if greater than 12,5 GHz, excluding the transmitter exclusion band for emissions. If spurious emissions are detected within -10 dB of the specified limit between 1,5 and 4 GHz, then the measurement shall continue to 12,75 GHz. If the operating frequency of the EUT is greater than 6,375 GHz, the measurement frequency range shall extend up to and including twice the maximum operating frequency.

Table 6: Bandwidth requirements

Frequency range	6 dB bandwidth
150 kHz to 30 MHz	9 MHz to 10 kHz
30 MHz to 1 000 MHz	100 MHz to 120 kHz
> 1 000 MHz	1 MHz

To improve measurement sensitivity or to avoid spillover from the wanted emission into the measurement receiver bandwidth filters, the measurement bandwidth B may be reduced when measuring close to F_c . Where spectrum analysers or similar instruments are used to perform the measurement, the measurement bandwidth may be reduced in order to improve measurement sensitivity. The total peak power of the all spurious emissions in the bandwidth above shall be used to determine whether the requirements are met. A peak detector complying with CISPR 16-1 [4] shall be used.

Table 7: Transmitter exclusion band for emissions

Necessary bandwidth of emission	Exclusion band	Exclusion band centre
$F_n < 0,05 F_c$	$3 F_n + F_b$	F_c
$F_n > 0,05 F_c$	$1,1 F_n + F_b$	F_c

Where:

- F_n = Necessary bandwidth of the wanted class of emission as defined in ITU RR [1] 1-18 clause 146;
- F_b = 200 kHz in the frequency range below 30 MHz;
- F_b = 2 MHz in the frequency range above 30 MHz;
- F_c = Centre frequency of the transmitter necessary bandwidth.

5.3.1.2 Limits

In transmit mode the equipment shall comply with the limits in subclause 4.2.1.2, table 1.

In receive and/or standby mode the equipment shall comply with the limits in subclause 4.2.1.2, table 2.

5.3.2 Unwanted emissions, radiated

5.3.2.1 Method of measurement

Radiated emission measurements shall be performed using the substitution method.

A test antenna shall be used to detect the radiation from the EUT. This antenna is mounted on a non conducting support such as to allow the antenna to be used in either horizontal or vertical polarization and for the height of its centre above ground to be varied over the range 1 to 4 m. Preferably a test antenna with pronounced directivity should be used. The size of the test antenna along the measurement axis shall not exceed 20 % of the measuring distance.

For EUT radiation measurements, the test antenna is connected to a measuring receiver, capable of being tuned to any frequency under investigation and of measuring the levels of signals at its input.

The substitution antenna and signal generator is used to replace the equipment under test in substitution measurements. For measurements below 1 GHz, the substitution antenna shall be half wavelength dipole resonant at the frequency under consideration, or a shortened dipole, calibrated to the half wavelength dipole. For measurements between 1 and 4 GHz, either a half wavelength dipole or a horn radiator may be used. For measurements above 4 GHz a horn radiator shall be used. The centre of this antenna shall coincide with the reference point of the test sample it has replaced. This reference point shall be the volume centre of the sample when its antenna is mounted inside the cabinet, or the point where an outside antenna is connected to the cabinet.

The distance between the lower extremity of the test antenna and the ground shall not be less than 0,3 m.

Evidence indicates that the measuring distance is not critical and does not significantly affect the measuring results, provided that the distance is not less than $\lambda/2$ at the frequency of measurement, and the precautions described in this clause are observed. Measuring distances of 3, 5, 10 and 30 m are in common use in European test laboratories.

For frequencies above 1 GHz, a smaller measuring distance may be used provided it is greater than five times the maximum dimension of the EUT and five times the maximum dimension of the measurement antenna and five times the dimension of the substitution antenna and exceeds one half-wavelength at the test frequency.

The position of auxiliary cables (power supply etc.) which are not adequately decoupled may cause variations in the measuring results. In order to get reproducible results, cables and wires of auxiliary equipment should be arranged vertically downwards decoupled to the ground plane.

The EUT shall be placed on the support in its standard position and switched on.

The test antenna shall be oriented initially for vertical polarization. The test antenna shall be raised or lowered through the specified height range until the maximum signal level is detected.

The EUT shall be rotated through 360° about a vertical axis to maximize the detected signal.

The test antenna shall be raised or lowered again, if necessary, through the specified height range until a maximum is obtained. This level shall be recorded.

This measurement shall be repeated for horizontal polarization.

The substitution antenna shall replace the EUT in the same position and with vertical polarization. The frequency of the signal generator shall be adjusted to the frequency under investigation.

The rotation and height scans to maximize the detected signal shall be repeated.

The input signal to the substitution antenna shall be adjusted in level until an equal or a known related level to that detected from the EUT is obtained in the test receiver.

The entire measurement sequence shall be repeated with horizontal positioning of the antennas.

The radiated power is equal to the power supplied by the signal generator, modified by the known relationship if necessary and after corrections due to the gain of the substitution antenna and the cable loss between the signal generator and the substitution antenna.

The measurement frequency range extends from 30 MHz to 12,5 GHz or $2 \times F_c$ if greater than 12,5 GHz, excluding the transmitter exclusion band for emissions. If spurious emissions are detected within -10 dB of the specified limit between 1,5 and 4 GHz, then the measurement shall continue to 12,75 GHz. If the operating frequency of the EUT is greater than 6,375 GHz, the measurement frequency range shall extend up to and including twice the maximum operating frequency.

Table 8: Bandwidth requirements

Frequency range	6 dB Bandwidth
30 MHz to 1 000 MHz	100 MHz to 120 kHz
> 1 000 MHz	1 MHz

To improve measurement sensitivity or to avoid spillover from the wanted emission into the measurement receiver bandwidth filters when measuring close to F_c , the measurement of narrow band spurious emissions may be performed with a bandwidth smaller than the above. The total peak power of the all spurious emissions in the bandwidth above shall be used to determine whether the requirements are met. A peak detector complying with CISPR 16-1 [4] shall be used.

Table 9: Transmitter exclusion band for emissions

Necessary bandwidth of emission	Exclusion band	Exclusion band centre
$F_n < 0,05 F_c$	$3 F_n + F_b$	F_c
$F_n > 0,05 F_c$	$1,1 F_n + F_b$	F_c

Where:

- F_n = Necessary bandwidth of the wanted class of emission as defined in ITU RR [1] 1-18 clause 146;
- F_b = 200 kHz in the frequency range below 30 MHz;
- F_b = 2 MHz in the frequency range above 30 MHz;
- F_c = Centre frequency of the transmitter necessary bandwidth.

5.3.2.2 Limits

In transmit mode the equipment shall comply with the limits shown in subclause 4.2.2.2, table 3.

In receive and/or standby mode the equipment shall comply with the limits shown in subclause 4.2.2.2, table 4.

5.4 Other test specifications

5.4.1 Conducted RF immunity

5.4.1.1 Method of measurement

The two input signals shall be connected to the receiver via a combining network.

Test signal sources which are applied to the receiver shall present an impedance of 50 Ω to the receiver input. This requirement shall be met irrespective whether one or more signals using a combining network are applied to the receiver simultaneously.

Receivers which require source impedances other than 50 Ω as specified by the manufacturer, shall be achieved by an impedance transformer placed between the 50 Ω combining network and the receiver input.

The levels of the test signals shall be expressed in terms of the electromotive force (e.m.f.) at the receiver input connector.

The effects of any intermodulation products and noise produced in the test signal sources shall be negligible.

The wanted test signal, at the nominal frequency of the receiver, with normal test modulation, (see table 10), shall be applied to the receiver input connector via one input of the combining network at a nominal value of 60 dB (or a lower value as declared by the manufacturer) above the maximum usable sensitivity of the EUT as declared by the manufacturer in the product documentation.

Table 10: test signal

Mode	Units	Modulation
AM	60	% AM (1 kHz)
FM	60	% of the maximum permissible frequency deviation (1 kHz)
SSB	1 kHz offset	None
Other modes	as declared by the manufacturer	as declared by the manufacturer

For analogue communication (speech):

- where possible, the receiver volume control shall be adjusted to give at least 50 % of the rated output power as declared by the manufacturer, or in the case of stepped volume controls, to the first step that provides an output power of at least 50 % of the rated output power.

For non-speech communication:

- the modulation facilities shall be declared by the manufacturer.

The test shall be performed over the frequency range 150 kHz to 1 GHz using stepped increments of maximum 1 % of the momentary frequency with the exception of the exclusion band.

The exclusion band for a receiver and the receiver of a transceiver is determined by the characteristics of the equipment.

In the case of receivers operating on a fixed single frequency, the exclusion band extends from minus 5 % to plus 5 % of the fixed single frequency.

In the case of receivers operating, or capable of operating, on a number of spot frequencies in a narrow operating frequency band which is less than 20 % of the centre frequency of the operating band, the exclusion band extends from minus 5 % of the lowest frequency of the narrow operating frequency band to plus 5 % of the highest frequency of that band.

In the case of receivers operating, or capable of operating on a number of spot frequencies over a wide frequency band, the exclusion band for each of the wanted signal test frequencies shall extend from minus 5 % to plus 5 % of each wanted signal test frequency.

The test shall be applied to the receiver input connector via the second input of the combining network.

Application of the test signal shall not cause the demodulated receiver output to:

- be reduced to less than 12dB SINAD for analogue speech equipment; or
- be reduced to less than 80% of the original data throughput for non-speech equipment; or
- be degraded to a level declared by the manufacturer as appropriate for the type of signal conveyed.

Discrete spurious responses shall be ignored.

5.4.1.2 Limits

The equipment shall comply with the limits shown in subclause 4.2.3.2.

Bibliography

The following material, though not specifically referenced in the body of the present document (or not publicly available), gives supporting information.

- ETSI EN 301 489-15: "Electromagnetic Compatibility and Radio Spectrum Matters (ERM); EMC standard for radio equipment and services. Part 15: Specific requirements for Amateur Radio".

History

Document history			
V1.1.1	March 2000	One-step Approval Procedure	OAP 20000728: 2000-03-29 to 2000-07-28