

Draft **ETSI EN 301 776** V1.1.1 (2000-02)

---

*European Standard (Telecommunications series)*

**Broadband Private Integrated Services Networks (B-PISNs);  
Inter-exchange signalling protocol;  
Separated Bearer Control (SBC)**

---



---

**Reference**

DEN/ECMA-00160

---

**Keywords**B-ISDN, B-QSIG, broadband, PINX, PISN,  
private, protocol**ETSI**

---

**Postal address**

F-06921 Sophia Antipolis Cedex - FRANCE

---

**Office address**650 Route des Lucioles - Sophia Antipolis  
Valbonne - FRANCE  
Tel.: +33 4 92 94 42 00 Fax: +33 4 93 65 47 16  
Siret N° 348 623 562 00017 - NAF 742 C  
Association à but non lucratif enregistrée à la  
Sous-Préfecture de Grasse (06) N° 7803/88

---

**Internet**secretariat@etsi.fr  
Individual copies of this ETSI deliverable  
can be downloaded from  
<http://www.etsi.org>  
If you find errors in the present document, send your  
comment to: editor@etsi.fr

---

**Important notice**

This ETSI deliverable may be made available in more than one electronic version or in print. In any case of existing or perceived difference in contents between such versions, the reference version is the Portable Document Format (PDF). In case of dispute, the reference shall be the printing on ETSI printers of the PDF version kept on a specific network drive within ETSI Secretariat.

---

**Copyright Notification**

No part may be reproduced except as authorized by written permission.  
The copyright and the foregoing restriction extend to reproduction in all media.

© European Telecommunications Standards Institute 2000.  
All rights reserved.

# Contents

Intellectual Property Rights.....	5
Foreword .....	5
Brief History.....	5
1 Scope.....	6
2 Conformance .....	6
3 References.....	6
4 Definitions.....	7
4.1 External definitions .....	7
4.2 Other definitions.....	7
5 Abbreviations .....	8
6 Description .....	8
6.1 Separation of call control and bearer control.....	8
6.2 Relationship to call control architecture .....	9
6.3 Capabilities supported by the present document .....	9
6.4 General overview.....	9
7 Operational requirements .....	10
7.1 Provision and withdrawal .....	10
7.2 Requirements on the preceding side .....	10
7.3 Requirements on the succeeding side .....	10
8 Primitive definitions and state definitions .....	10
8.1 Primitive definitions .....	10
8.2 State definitions.....	10
8.2.1 B-QSIG connection states.....	10
9 Coding requirements .....	11
9.1 Messages .....	11
9.1.1 Modification to messages defined in ECMA-266.....	11
9.1.1.1 SETUP .....	11
9.1.1.2 Other messages.....	11
9.2 Information elements.....	11
9.2.1 Call association.....	12
9.2.2 Bearer identifier.....	13
9.2.3 Other information elements.....	13
10 Signalling procedures at the Q reference point.....	13
10.1 Introduction .....	13
10.2 Establishment of a bearer .....	14
10.2.1 Additional procedures at a preceding side .....	14
10.2.1.1 Additional procedures at a preceding PINX with coordination function.....	14
10.2.1.2 Additional procedures at a preceding PINX without co-ordination function .....	14
10.2.2 Additional procedures at a succeeding side .....	14
10.2.2.1 Additional procedures at a succeeding PINX without co-ordination function .....	15
10.2.2.2 Additional procedures at a succeeding PINX with co-ordination function .....	15
10.3 Procedures for joining bearer connections on adjacent call segments.....	15
10.4 Additional procedures at a Transit PINX .....	15
10.5 Clearing of a Connection.....	15

11	Interworking with other networks .....	16
12	Interworking with supplementary services .....	16
13	Parameter values .....	16
14	Dynamic description SDLs .....	16
<b>Annex A (normative): Protocol Implementation Conformance Statement (PICS) proforma .....</b>		<b>17</b>
A.1	Introduction .....	17
A.1.1	Basic reference documents for PICS proforma specifications .....	17
A.1.2	Copyright Information .....	17
A.1.3	Structure of this PICS proforma .....	17
A.2	Instructions .....	18
A.2.1	Purpose of a PICS proforma .....	18
A.2.2	Instructions for completing the PICS proforma .....	19
A.2.3	Additional Information .....	19
A.2.4	Exception Information .....	19
A.2.5	Legend for the columns of the PICS proforma tables .....	19
A.2.6	Legend for further indications of the PICS proforma tables .....	20
A.3	Identification of the implementation .....	21
A.3.1	Date of statement .....	21
A.3.2	Identification of the implementation .....	21
A.3.3	Identification of the system in which it resides .....	22
A.3.4	Product supplier .....	22
A.3.5	Client .....	23
A.3.6	PICS contact person .....	23
A.3.7	Protocol for which this PICS applies .....	24
A.4	Global Statement of Conformance .....	24
A.5	Roles .....	25
A.6	Major capabilities .....	25
A.7	Subsidiary capabilities .....	26
A.8	PDU parameters received by the succeeding side .....	26
A.9	PDU parameters sent by the preceding side .....	27
A.10	PDU parameters received by the succeeding side .....	26
A.11	Timers .....	27
A.12	Call states .....	27
<b>Annex B (informative): Guidelines for the use of the instruction indicator .....</b>		<b>28</b>
History .....		29

---

## Intellectual Property Rights

IPRs essential or potentially essential to the present document may have been declared to ETSI. The information pertaining to these essential IPRs, if any, is publicly available for **ETSI members and non-members**, and can be found in SR 000 314: "*Intellectual Property Rights (IPRs); Essential, or potentially Essential, IPRs notified to ETSI in respect of ETSI standards*", which is available from the ETSI Secretariat. Latest updates are available on the ETSI Web server (<http://www.etsi.org/ipr>).

Pursuant to the ETSI IPR Policy, no investigation, including IPR searches, has been carried out by ETSI. No guarantee can be given as to the existence of other IPRs not referenced in SR 000 314 (or the updates on the ETSI Web server) which are, or may be, or may become, essential to the present document.

---

## Foreword

This European Standard (Telecommunications series) has been produced by ETSI Technical Committee European Computer Manufacturers Association (ECMA) on behalf of its members and those of the European Telecommunications Standards Institute (ETSI), and is now submitted for the ETSI standards One-step Approval Procedure.

<b>Proposed national transposition dates</b>	
Date of latest announcement of this EN (doa):	3 months after ETSI publication
Date of latest publication of new National Standard or endorsement of this EN (dop/e):	6 months after doa
Date of withdrawal of any conflicting National Standard (dow):	6 months after doa

---

## Brief History

The present document is one of a series of ECMA Standards defining services and signalling protocols applicable to Broadband Private Integrated Services Networks (B-PISNs). The series uses B-ISDN concepts as developed by ITU-T and conforms to the framework of International Standards for Open Systems Interconnection as defined by ISO/IEC. It has been produced under ETSI work item DEN/ECMA-00160.

The present document specifies the signalling protocol for use at the Q reference point for separated bearer control (B-QSIG-SBC).

The present document is based upon the practical experience of ECMA member companies and the results of their active and continuous participation in the work of ISO/IEC JTC1, ITU-T, ETSI and other international and national standardization bodies. It represents a pragmatic and widely based consensus.

The present document has been adopted by the ECMA General Assembly of December 1999.

---

## 1 Scope

The present document defines the signalling protocol for the purpose of bearer control at the Q-reference point between Private Integrated Services Network Exchanges (PINXs) connected together within a Broadband Private Integrated Services Network (B-PISN) employing Asynchronous Transfer Mode (ATM). The present document is part of the B-QSIG signalling system.

The present document specifies the essential features, procedures, and messages required for establishing, maintaining and clearing of bearer connections to point-to-point multiconnection calls at the B-QSIG interface in a functionally separated call and bearer control environment. Bearers are controlled independently by means of a separated call control protocol. The separated call control protocol is assumed to be that specified in ECMA-294 [4].

The present document is applicable to PINXs that support separated call and bearer control protocol at the Q reference point. The Q reference point is defined in ISO/IEC 11579-1 [2].

---

## 2 Conformance

In order to conform to the present document, a PINX shall satisfy the requirements identified in the Protocol Implementation Conformance Statement (PICS) proforma in annex A.

---

## 3 References

The following documents contain provisions which, through reference in this text, constitute provisions of the present document.

- References are either specific (identified by date of publication, edition number, version number, etc.) or non-specific.
- For a specific reference, subsequent revisions do not apply.
- For a non-specific reference, the latest version applies.
- A non-specific reference to an ETS shall also be taken to refer to later versions published as an EN with the same number.

- [1] ECMA-266: "Broadband Private Integrated Services Network (B-PISN) – Inter-Exchange Signalling Protocol – Basic Call/Connection Control (B-QSIG-BC) (International Standard ISO/IEC 13247)".
- [2] ISO/IEC 11579-1: "Information technology - Telecommunications and information exchange between systems - Private integrated services network - Part 1: Reference configuration for PISN Exchanges (PINX)".
- [3] ITU-T Recommendation I.371: "Traffic control and congestion control in B-ISDN".
- [4] ECMA-294: "Broadband Integrated Services Digital Network (B-ISDN) and Broadband Private Integrated Services Network (B-PISN) - Digital Subscriber Signalling System No. two (DSS2), Broadband Inter-Exchange Signalling (B-QSIG), and Signalling System No. 7 (SS7) - Call Control in a Separated Call and Bearer Control Environment - Part 1: Protocol Specification".
- [5] CCITT Recommendation Q.9: "Vocabulary of switching and signalling terms".
- [6] ITU-T Recommendation I.112: "Vocabulary of terms for ISDNs".
- [7] ITU-T Recommendation I.321: "B-ISDN protocol reference model and its application".
- [8] ISO/IEC 9646-1: "Information technology - Open Systems Interconnection - Conformance testing methodology and framework - Part 1: General concepts".

- [9] ISO/IEC 9646-7: "Information technology - Open Systems Interconnection - Conformance testing methodology and framework - Part 7: Implementation Conformance Statements".

---

## 4 Definitions

For the purposes of the present document the following terms and definitions apply.

### 4.1 External definitions

The present document uses the following terms defined in other documents:

**ATM transfer capability (ATC):** see ITU-T Recommendation I.371 [3]

**bearer:** see ECMA-294 [4]

**bearer control:** see ECMA-294 [4]

**bearer control entity (BC entity):** see ECMA-294 [4]

**call:** see ECMA-294 [4]

**call control:** see ECMA-294 [4]

**call control entity (CC entity):** see ECMA-294 [4]

**call control signalling service user:** see ECMA-294 [4]

**connection:** see CCITT Recommendation Q.9 [5]

**Inter-PINX Link (IPL):** see ECMA-266 [1]

**private integrated services network (PISN):** see ISO/IEC 11579-1 [2]

**private integrated services network exchange (PINX):** see ISO/IEC 11579-1 [2]

**signalling:** see ITU-T Recommendation I.112 [6]

**user plane:** see ITU-T Recommendation I.321 [7]

### 4.2 Other definitions

**connection state:** state for each connection which is known by the layer 3 bearer control entity

**bearer identifier:** identifier used to identify a bearer instance within a call segment. The value of the bearer identifier is significant between two adjacent call control entities. This value is unique within a call segment

**call segment:** part of a call located between two adjacent call control entities

**call segment identifier:** identifier used to identify a multiconnection call instance to which a particular bearer establishment request relates between two call control entities at a given B-QSIG interface. The value of a call segment identifier is unique within two adjacent call control entities

**preceding side:** with respect to a given bearer, the side of a B-QSIG interface from which bearer establishment across the interface originates

**succeeding side:** with respect to a given bearer, the side (opposite to the preceding side) of a B-QSIG interface which receives the bearer establishment request across the interface

**side:** protocol control entity in a PINX at one end of an IPL

**signalling AAL (SAAL):** AAL used for the bi-directional transfer of layer 3 signalling information

**preceding PINX:** PINX at the preceding side

**succeeding PINX:** PINX at the succeeding side

**preceding PINX with call/bearer co-ordination:** preceding PINX providing co-ordination between the call control (CC) and the bearer control (BC) entity functionality. Both CC and BC entity functionality have to be supported on this PINX

**preceding PINX without co-ordination function:** preceding PINX providing no co-ordination between the call control (CC) and the bearer control (BC) entity functions. Only BC entity functions have to be supported on this PINX

**succeeding PINX without co-ordination function:** succeeding PINX providing no co-ordination between the call control (CC) and the bearer control (BC) entity functions. Only BC entity functions have to be supported on this PINX

**succeeding PINX with co-ordination function:** succeeding PINX providing co-ordination between the call control (CC) and the bearer control (BC) entity functions. Both CC and BC entity functions have to be supported on this PINX

## 5 Abbreviations

For the purposes of the present document, the following abbreviations apply:

AAL	ATM Adaptation Layer
ATM	Asynchronous Transfer Mode
BC	Bearer Control
B-ISDN	Broadband Integrated Services Digital Network
B-PISN	Broadband Private Integrated Services Network
CC	Call Control
DSS2	Digital Subscriber Signalling System No 2
IPL	Inter- PINX Link
PINX	Private Integrated services Network eXchange
SAAL	Signalling ATM Adaptation Layer
SBC	Separated Bearer Control
SDL	Specification and Description Language

## 6 Description

### 6.1 Separation of call control and bearer control

The protocol specified in the present document is applicable to an environment in which the control of a call is separate from the control of the bearer or bearers that exist within the context of that call.

In order for two users to communicate using a telecommunication service, an association, or call, is established between the two users. Within the context of the call, one or more bearers can be established for transporting user plane information between the users. However, bearers are not normally established until the call has been accepted by the called terminal, and therefore resources required by bearers are not occupied unnecessarily if the call cannot be established, e.g., if the called terminal is unable to accept the call because resources are not available. During the lifetime of the call, bearers can be added or cleared down as required. The call is terminated by one of the two users when there is no further need for communication. Termination of the call implies that all bearers (if any) are cleared down.

Although for some telecommunication services a single bearer is sufficient, other telecommunication services benefit from the use of multiple bearers; each tailored to suit the characteristics of the user plane information to be transported. This is particularly true for multi-media applications involving audio, video and data. The call provides a context in which the various bearers can exist and a means of binding the bearers together.



## 6.2 Relationship to call control architecture

Bearer control requires functionality, and hence a BC entity, at each terminal and at every network node through which the bearer is routed. This is in contrast to call control, which involves a CC entity only at the terminals and selected network nodes. Each bearer can be routed independently of other bearers and independently of the routing of call control signalling associations. However, each bearer is required to be routed through each network node at which there is a CC entity, and hence have a BC entity at each of these nodes, so that the CC entity can manage the bearer if required. This is illustrated in Figure 1 and a single bearer that has a BC entity collocated with each CC entity and an additional BC entity (e.g. at a transit node) located between the second and third CC entities.

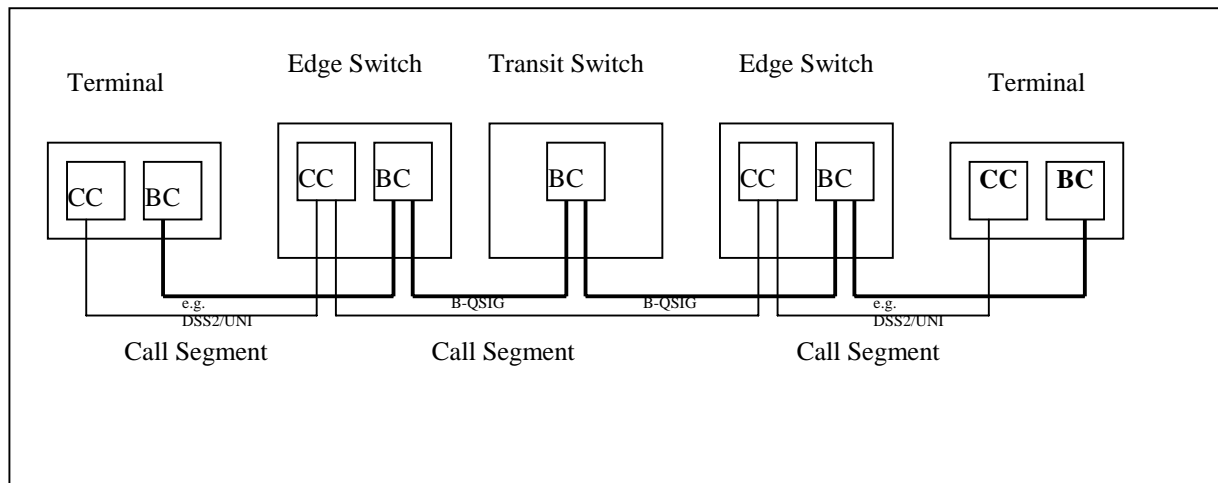

NOTE: Signalling between CC entities is outside the scope of the present document.

**Figure 1: Relationship of call control and bearer control architecture**

## 6.3 Capabilities supported by the present document

The present document builds upon the capabilities in ECMA-266 [1] to enable the separate control of bearers being associated to a multiconnection call.

## 6.4 General overview

The present document presents the procedures, messages and information elements needed for establishing, maintaining and clearing of bearer connections being associated to a point-to-point multiconnection call.

After a multiconnection call has been initiated or has progressed to the active state, bearer connections can be added to the call by individual bearer connection setup requests from the calling party or the called party, using the separated bearer control protocol specified in the present document, which are based on the procedures of ECMA-266 [1]. Each new connection setup request shall use a new call reference (see clause 9 of ECMA-266 [1]). Bearers may be established or released from the multiconnection call at any time while not modifying the call state. New connections can be established by the calling party or the called party by sending a SETUP message as defined in ECMA-266 [1], which in addition contains the Call association information element in order to associate that bearer to the multiconnection call. The calling party or the called party can release connections from the call by sending a RELEASE message as defined in ECMA-266 [1].

The individual bearers are controlled independently. In particular multiple bearer connection establishment requests may be initiated in parallel (i.e. the requesting party does not need to wait for a response related to one bearer connection setup request before issuing another one). Similarly, multiple bearer connection release requests may be pending at the same time (i.e. the requesting party does not need to wait for a response related to one release connection request before issuing the next one).

Any ATM transfer capability available at the interface may be requested independently for each of the bearers associated to a multiconnection call, using appropriate basic call information elements (see subclauses 8.5.7 to 8.5.10 of ECMA-266 [1]). Furthermore, the ATM traffic parameter negotiation applies independently to each bearer at bearer establishment time using the procedures defined in subclause 9.2 of ECMA-266 [1].

---

## 7 Operational requirements

### 7.1 Provision and withdrawal

The provision of this capability is within a single private network.

### 7.2 Requirements on the preceding side

None beyond the support of the multiconnection call capability related control protocols.

### 7.3 Requirements on the succeeding side

None beyond the support of the multiconnection call capability related control protocols.

---

## 8 Primitive definitions and state definitions

### 8.1 Primitive definitions

Subclause 6.3 of ECMA-266 [1] shall apply. No additional primitives between B-QSIG layer 3 and the Signalling ATM Adaptation Layer are defined for the purpose of the present document.

### 8.2 State definitions

#### 8.2.1 B-QSIG connection states

The bearer connection states that may exist on the preceding or succeeding side of the B-QSIG interface coincide with the call/connection states defined in subclause 6.4.1 of ECMA-266 [1]. The bearer control entity maintains the current state of each individual bearer independently.

The bearer connection states corresponding to the call/connection states relating to Transit PINX shall be applicable as defined in subclause 6.5 of ECMA-266 [1].

The bearer connection states corresponding to the additional call/connection states relating to interworking requirements, as defined in subclause 6.4.2 of ECMA-266 [1], are not applicable although may be available if the point-to-point call/connection control capability (using the ECMA-266 [1] basic call control protocol) interworking with existing services or networks (i.e. operating exclusively the combined call/bearer control protocols) is supported.

## 9 Coding requirements

### 9.1 Messages

Messages are defined in accordance with the principles given by the introductory paragraph in clause 7 of ECMA-266 [1]. Only changes to messages defined in subclause 7.1 of ECMA-266 [1] are specified in this clause. Messages defined for point-to-multipoint call/connection in subclause 7.3 of ECMA-266 [1] are not applicable for the present document.

#### 9.1.1 Modification to messages defined in ECMA-266

The following modifications apply to the messages defined in subclause 7.1 of ECMA-266 [1]. However they do not apply, unless otherwise explicitly stated, to the messages relating to the support of 64 kb/s based ISDN circuit-mode services (subclause 7.2 of ECMA-266 [1]) even if the interworking of multiconnection calls with these services (or interworking with networks providing these services) is supported.

Table 1 lists the existing subclause 7.1 of ECMA-266 [1] messages that have had their contents modified to support the establishment/release of bearer connections in a point-to-point multi-connection call controlled by means of separated call and bearer control protocols.

**Table 1: Modified ECMA-266 [1] messages**

Message	Reference
SETUP	9.1.1.1

##### 9.1.1.1 SETUP

This message is sent by the preceding side to the succeeding side to initiate an individual bearer connection establishment.

See table 2 for additions to the structure of this message shown in table 5 of ECMA-266 [1].

**Table 2: SETUP message additional contents**

Information Element	Reference	Type	Length
Call association	9.2.1	O (Note)	9
Bearer identifier	9.2.2	O	7
NOTE: Mandatory when the message is used to add a bearer to a multiconnection call			

##### 9.1.1.2 Other messages

If interworking between multiconnection call supported services and 64 kb/s based ISDN circuit mode services is supported, the messages defined in subclause 7.2 of ECMA-266 [1] apply. In addition the SETUP ACKNOWLEDGE and INFORMATION (subclause 7.2.7 of ECMA-266 [1]) message are not supported.

### 9.2 Information elements

The information elements and coding rules of subclauses 8.1 to 8.6 of ECMA-266 [1] shall apply with the additions or modifications identified in the following subclauses.

## 9.2.1 Call association

The purpose of the Call association information element is to identify the call to which the bearer in the process of being established relates. The call segment identifier value has significance between the two peer call control entities between which the bearer is being established.

NOTE: The assignment of the call segment identifier value is initiated by the originating side of the first message referring to the establishment of the multi-connection call.

The Call association information element is coded as shown in figure 2 and table 3.

Bits								Octets
8	7	6	5	4	3	2	1	
Call association								1
1	0	0	1	0	0	1	1	
Information element identifier								
1	Coding standard		IE instruction field					2
ext			Flag	Res.	IE Action Ind			
Length of Call association contents								3
Length of Call association contents (continued)								4
Identifier for Call segment identifier value								5
0	0	0	0	0	0	1	0	
Call segment identifier value								5.1 to 5.4

**Figure 2: Call association information element**

**Table 3: Call association information element coding**

- |   |
|---|
| - Octets 1 through 4 are coded according to the coding rules specified in subclause 8.5 of ECMA-266 [1]. A call segment identifier (octet group 5) shall be included. |
| - The call segment identifier value field (octets 5.1 to 5.4), contains the call segment identifier value, as defined in Standard ECMA-294 [4].                       |

## 9.2.2 Bearer identifier

The purpose of the Bearer identifier information element is to relate a bearer in the process of being established to a bearer object known to peer call control entities within the context of a multiconnection call. The bearer identifier value has significance only between the two peer call control entities between which the bearer is being established.

The Bearer identifier information element is coded as shown in figure 3 and in table 4.

Bits	7	6	5	4	3	2	1	Octets
Bearer identifier	1	0	0	1	0	0	0	1
Information element identifier								1
1	Coding standard		IE instruction field					2
ext			Flag	Res.	IE Action Ind			
Length of Bearer identifier contents								3
Length of Bearer identifier contents (continued)								4
0/1	Bearer identifier value							5
Bearer identifier flag								
Bearer identifier value (continued)								6
Bearer identifier value (continued)								7

**Figure 3: Bearer identifier information element**

**Table 4: Bearer identifier information element coding**

- Octets 1 through 4 are coded according to the coding rules specified in subclause 8.5 of ECMA-266 [1].
- Bearer identifier flag (Octet 5)

Bit

8

0 The message is sent from the side that originated the bearer identifier.

1 The message is sent to the side that originated the bearer identifier.

- Bearer identifier value (Octets 5, 6 and 7)

The bearer identifier is a 23-bit integer (coded in binary) to uniquely identify a bearer within a multiconnection call.

## 9.2.3 Other information elements

The Broadband sending complete information element (subclause 8.5.14 of ECMA-266 [1]) is not applicable. However its use is optional and its presence or absence in the SETUP message shall not incur an error situation.

The information elements defined for the support of 64 kb/s based ISDN circuit mode services (subclause 8.6 of ECMA-266 [1]) apply only when their interworking with multiconnection call supported services is provided.

---

# 10 Signalling procedures at the Q reference point

## 10.1 Introduction

Before the procedures described in this clause are invoked, an assured mode signalling AAL connection shall be established as specified in subclause 9.1 of ECMA-266 [1].

The procedures specified in this clause cover the following capabilities:

- a) addition of bearers to multiconnection call being established or having progressed to the active state;
- b) release of bearers from an existing call, while maintaining the call active, including when no more bearers exist.

NOTE: Any of the users may initiate bearer establishment or clearing.

The procedures for basic (and simultaneous) call/connection control as defined in clause 9 of ECMA-266 [1] shall apply as the basis for the separated bearer control. Only additional procedures required to handle the separated bearer control functions of a multiconnection call are described in the following subclauses.

## 10.2 Establishment of a bearer

As soon as the multiconnection call has been initiated and the initiating call control entity has received an indication that call establishment is proceeding, one or more bearer additions to the call may be initiated.

### 10.2.1 Additional procedures at a preceding side

The bearer control entity requesting the addition of a bearer to a multiconnection call shall send a SETUP message with a new call reference and containing a Call association information element specifying the call to which the bearer establishment request relates.

The SETUP message shall contain the Called party number information element, and optionally a Called party subaddress information element, containing the address(es) provided by the call control entity.

Upon receipt from bearer control of an indication that the bearer establishment request has been accepted and proceeds, the local call control signalling service user entity can associate the bearer (identified by the bearer identifier value in the Bearer identifier information element, if present, or the call reference in the received message) to the multiconnection call (identified by the call segment identifier value contained in the Call association information element).

#### 10.2.1.1 Additional procedures at a preceding PINX with coordination function

When sending a SETUP message, a preceding side that is a point of call/bearer co-ordination shall place in the Called party number information element the called party number supplied by the local call control signalling service user.

It shall also include in the SETUP message a Call association information element containing a call segment identifier value supplied by the local call control signalling service user.

In addition, it shall include in the SETUP message a Bearer identifier information element containing a bearer identifier value if supplied by the local call control signalling service user.

#### 10.2.1.2 Additional procedures at a preceding PINX without co-ordination function

When sending a SETUP message, a preceding side that is not a point of call/bearer co-ordination shall place in the Called party number information element the called party number received in the SETUP message from the previous point of call/bearer co-ordination.

It shall also include in the SETUP message a Call association information element containing a call segment identifier value that has been received in the SETUP message from the previous point of call/bearer co-ordination.

In addition, it shall include in the SETUP message a Bearer identifier information element if a bearer identifier value has been received in the SETUP message from the previous point of call/bearer co-ordination. Otherwise the Bearer identifier information element shall be omitted.

### 10.2.2 Additional procedures at a succeeding side

On receipt of a SETUP message containing a Call association information element, the succeeding side shall determine whether it is the point of call/bearer co-ordination addressed by the Called party number information element. If so, the procedures of 10.2.2.2 shall apply, otherwise the procedures of 10.2.2.1 shall apply.

The bearer control entity receiving a SETUP message specifying a call segment identifier value which is not recognized as relating to an existing multiconnection call, shall reject the bearer establishment request by sending a RELEASE COMPLETE message with cause #101, 'message not compatible with call state'.

### 10.2.2.1 Additional procedures at a succeeding PINX without co-ordination function

A succeeding side that is not a point of call/bearer co-ordination shall forward the bearer establishment request, based on information in the received SETUP message, towards the next point of call/bearer co-ordination, as addressed by the number in the received Called party number information element.

It shall also pass forward in the SETUP message towards the next point of call/bearer co-ordination the call segment identifier value received in the Call association information element present in the received SETUP message.

In addition, it shall pass forward in the SETUP message towards the next point of call/bearer co-ordination the bearer identifier value received in the Bearer identifier information element, if present in the received SETUP message.

### 10.2.2.2 Additional procedures at a succeeding PINX with co-ordination function

A succeeding side that is a point of call/bearer co-ordination shall forward the bearer establishment request based on information in the received SETUP message to the local call control signalling service user.

It shall also pass to the local call control signalling service user the call segment identifier value received in the Call association information element present in the received SETUP message.

NOTE 1: The call control service user can use this value to relate the bearer to an existing multiconnection call. Failure to relate the bearer to an existing multiconnection call can result in a rejection by the call control signalling service user of the bearer being requested to be established.

In addition, it shall pass to the local call control signalling service user the bearer identifier value in the Bearer identifier information element, if present in the received SETUP message.

NOTE 2: The call control service user can use this value to correlate the bearer against the call's object model. Failure to correlate can result in the call control signalling service user to reject the bearer being requested to be established.

## 10.3 Procedures for joining bearer connections on adjacent call segments

On request by CC, BC shall join corresponding bearer connections associated with the call. The corresponding bearer connections are identified by the call segment identifier value(s) and bearer identifier value(s).

## 10.4 Additional procedures at a Transit PINX

The procedures for handling of information elements at a Transit PINX as specified in subclause 12.1.9 of ECMA-266 [1] apply. The information elements: Call association and Bearer identifier shall be treated as Category 2 information elements (i.e. if they are present, they shall be passed unchanged onto the next PINX) by the Transit PINX.

## 10.5 Clearing of a Connection

Normal bearer connection clearing shall be initiated when requested by CC. Clearing procedures as specified in subclause 9.3 of ECMA-266 [1] apply. Clearing of a bearer connection does not affect the call state.

NOTE: Connection clearing is performed on a single call segment and does not imply automatic clearing of bearer connections on adjacent call segments.

In some abnormal conditions, BC can initiate bearer connection clearing. In this case, CC shall be notified.

---

## 11 Interworking with other networks

Interworking occurs with other networks, which do not support the separation of call control and bearer control or which send simultaneous call and bearer establishment requests.

Interworking with such networks requires both call control and bearer control functions in the gateway node at the boundary to these networks.

For interworking with networks which do not support the separation of call control and bearer control, see subclause C.1.1 to C.1.3 in annex C of ECMA-294 [4].

For interworking with networks that supports only simultaneous call and bearer establishment, see subclause C.2.2 and C.2.3 in annex C of ECMA-294 [4].

---

## 12 Interworking with supplementary services

Beyond the scope of the present Document.

---

## 13 Parameter values

No additional parameter required in addition to those defined in ECMA-266 [1].

---

## 14 Dynamic description SDLs

None required beyond those in annex D of ECMA-266 [1].

The messages SETUP ACKNOWLEDGE and INFORMATION are not supported in the present document, so the transitions associated with these messages are not applicable.



---

# Annex A (normative): Protocol Implementation Conformance Statement (PICS) proforma

Notwithstanding the provisions of the copyright clause related to the text of the present document, ETSI grants that users of the present document may freely reproduce the PICS proforma in this annex so that it can be used for its intended purposes and may further publish the completed PICS.

---

## A.1 Introduction

### A.1.1 Basic reference documents for PICS proforma specifications

General rules for the specification of PICS proforma are provided by ISO/IEC 9646-1 [8] . Detailed guidance for the specification of PICS proforma is provided by ISO/IEC 9646-7 [9] ; in particular the structure of a PICS proforma, the questions to be asked, the syntax and notation to be used and the semantics of the questions and expected answers.

For a PICS proforma, specific acronyms and terms are used as defined in ISO/IEC 9646-1 [8] or ISO/IEC 9646-7 [9] , e.g.:

ICS	Implementation Conformance Statement.
ICS proforma	Implementation Conformance Statement proforma.
ICS (proforma) item	A row in an ICS (proforma) table.
PICS	Protocol ICS.
PICS proforma	Protocol ICS proforma.
status (value)	An allowed entry in the status column for an item in an ICS proforma table.
(support) answer	An allowed entry in the support or supported values columns for an item in an ICS question.

### A.1.2 Copyright Information

Users of this specification may freely reproduce the PICS proforma of this annex A so that it can be used for its intended purpose and may further publish the completed PICS.

### A.1.3 Structure of this PICS proforma

This PICS proforma is subdivided into (sub-)clauses as follows:

- Instructions (A.2)
- Purpose of a PICS proforma (A.2.1)
- Instructions for completing the PICS proforma (A.2.2)
- Additional Information (A.2.3)
- Exception Information (A.2.4)
- Legend for the columns of the PICS proforma tables (A.2.5)

- Legend for further indications of the PICS proforma tables (A.2.6)
- Identification of the implementation (A.3), including:
- Identification of the protocol for which this PICS applies (A.3.7)
- Global statement of conformance (A.4)
- Roles (A.5)
- Major capabilities (A.6)
- Subsidiary capabilities (A.7)
- PDUs (A.8)
- PDU parameters received by the succeeding side (A.9)
- PDU parameters sent by the preceding side (A.10)
- Timers (A.11)
- Call states (A.12)

---

## A.2 Instructions

### A.2.1 Purpose of a PICS proforma

To evaluate conformance of a particular implementation, it is necessary to have a statement of which capabilities and options have been implemented for a given OSI specification. Such a statement is called an Implementation Conformance Statement (ICS).

For protocol specifications, this statement is called "Protocol Implementation Conformance Statement" (PICS). For the provision of this statement, a fixed format questionnaire called PICS proforma has to be used. A completed PICS proforma is the PICS for the implementation in question. It is an ICS (as defined in ISO/IEC 9646-7 [9] ) for an implementation or system which claims to conform to a given specification.

The PICS can have a number of uses, including:

- by the protocol implementor, as a check list for implementations to reduce the risk of unintended non-conformance, e.g. through oversight;
- by the supplier and acquirer, or potential acquirer, of the implementation, as a detailed indication of the capabilities of the implementation, stated relative to the common basis for understanding provided by the Standard's PICS proforma;
- by the user or potential user of the implementation, as a basis for initially checking the possibility of interworking with another implementation - while interworking can never be guaranteed, failure to interwork can often be predicted from incompatible PICS;
- by a protocol tester, as the basis for selecting appropriate tests against which to assess the claim for conformance of the implementation.

The PICS proforma of this annex therefore reflect a compromise between these different requirements.

## A.2.2 Instructions for completing the PICS proforma

The supplier of a protocol implementation which is claimed to conform to the present document shall complete the following Protocol Implementation Conformance Statement (PICS) proforma.

The PICS proforma is a fixed format questionnaire. The supplier of the implementation shall complete this questionnaire, in particular identify the implementation, complete the global statement of conformance, and provide the answers in the rows of the tables in clauses A.5 - A.12. The structure of the tables is explained in subclauses A.2.5 and A.2.6. For each row in each table, the supplier shall enter an explicit answer (i.e. by ticking the appropriate "yes", "no", or "N/A" in each of the support column boxes provided. Where a support column box is left blank, or where it is marked "N/A" without any tick box, no answer is required. If a "prerequisite line" (see A.2.6 below) is used after a subclause heading or table title, and its predicate is false, no answer is required for the whole subclause or table, respectively.

A supplier may also provide - or be required to provide - further information, categorized as either Additional Information or Exception Information. When present, each kind of further information is to be provided in a further subclause of items labelled:

- "a.<i>" for additional information;
- "x.<i>" for exceptional information

for cross-referencing purposes, where <i> is any unambiguous identification for the item (e.g., simply a numeral); there are no other restrictions on its format and presentation.

## A.2.3 Additional Information

Items of Additional Information allow a supplier to provide further information intended to assist the interpretation of the PICS. It is not intended or expected that a large quantity will be supplied, and a PICS can be considered complete without any such information. Examples might be an outline of the ways in which a (single) implementation can be set up to operate in a variety of environments and configurations.

References to items of Additional Information may be entered next to any answer in the questionnaire, and may be included in items of Exception information.

## A.2.4 Exception Information

It may occasionally happen that a supplier will wish to answer an item with mandatory or prohibited status (after any conditions have been applied) in a way that conflicts with the indicated requirement. No pre-printed answer will be found in the Support column for this. Instead, the supplier is required to write into the support column an x.<i> reference to an item of Exception Information, and to provide the appropriate rationale in the Exception item itself.

An implementation for which an Exception item is required in this way does not conform to the present document; and the answer to the global statement of conformance (see A.4) cannot be "yes". A possible reason for the situation described above is that a defect in the Standard has been reported, a correction for which is expected to change the requirement not met by the implementation.

## A.2.5 Legend for the columns of the PICS proforma tables

The questionnaire in clauses A.5-A.12 is structured as a set of tables in accordance with the guidelines presented in ISO/IEC 9646-7 [9]. The columns of the tables shall be interpreted as follows:

"Item"

The item column contains a unique reference (a mnemonic plus a number) for each item within the PICS proforma. Items need not always be numbered sequentially.

"Item Description"

The item description column contains a brief summary of the static requirement for which a support answer is required. This may be done by a question or a reference to a specific feature.

### "Conditions for Status"

The conditions for status column contains a specification, if appropriate, of the predicate upon which a conditional status is based. The indication of an item reference in this column indicates a simple-predicate condition (support of this item is dependent on the support marked for the referenced item).

Within the "conditions for status" column, the logical symbol "]" is used to indicate a logical negation ("NOT").

### "Status"

The following notations, as defined in ISO/IEC 9646-7 [9] , are used for the status column:

I	Irrelevant or out-of-scope - this capability is outside the scope of the Standard to which this PICS proforma applies and is not subject to conformance testing in this context.
M	Mandatory - the support of this capability is required for conformance to the Standard.
N/A	Not Applicable - in the given context, it is impossible to use the capability. No answer in the support column is required.
O	Optional - the capability is not required for conformance to the protocol and may be supported or not. However, if the capability is implemented, it is required to conform to the protocol specifications.
O.<n>	Qualified optional - in this case, <n> is an integer that identifies a unique group of related optional items. If no additional qualification is indicated, the support of at least one of the optional items is required for conformance to the Standard. Otherwise, the qualification and logic of the selection among the optional items is defined below the table explicitly.
X	eXcluded or prohibited - there is a requirement not to use this capability in a given context.

### "Reference"

Except where explicitly stated, the reference column refers to the appropriate subclause(s) of the present document describing the particular item. The reference merely indicates the place(s) where the core of a description of an item can be found; additional information on this item may be contained in other parts of the present document, and has to be taken into account when making a statement about the conformance to that particular item.

### "Support"

In the support column, the supplier of the implementation shall enter an explicit answer. The following notation is used:

Yes  No    Tick "yes", if item is supported; tick "No", if item is not supported.

N/A        Tick "N/A", if the item is "not applicable".

In specific cases, the indication of explicit values may be requested. Where a support column box is left blank, or where it is marked "N/A" without any tick box, no answer is required.

## A.2.6 Legend for further indications of the PICS proforma tables

In addition to the columns of a table, the following information may be indicated:

### "Prerequisite line"

A prerequisite line after a subclause heading or table title indicates that the whole subclause or the whole table is not required to be completed if the predicate is false. The prerequisite line takes the form:

Prerequisite:<predicate>.

### "Qualification"

At the end of a table, a detailed qualification for a group of optional items may be indicated, as specified in the description of the status "qualified optional" in subclause A.2.5.

"Comments"

This box at the end of a table allows a supplier to enter any comments to that table. Comments may also be provided separately (without using this box).

## A.3 Identification of the implementation

Identification of the implementation and the system in which it resides should be filled in to provide as much detail as possible regarding version numbers and configuration options.

The implementation about which this PICS proforma asks questions corresponds to a B-QSIG SBC implementation at the Q reference point.

Configuration options outlined in B-QSIG SBC have been incorporated into this PICS proforma. They are referred to by qualified options or prerequisite lines, in order to reflect that an implementation only needs to provide the addressed functions at an interface, if it is configured accordingly (e.g. an implementation only needs to provide gateway call handling functions, if it is configured to act as gateway PINX at an interface).

The contact person indicated (see A.3.6) should be able to answer queries regarding information supplied in the PICS.

As specified in clause 5 of ISO/IEC 9646-7 [9] , it is required for all implementations to at least provide the identification of the implementation (A.3.2), product supplier information (A.3.4), identification of a contact person (A.3.6), and detailed identification of the protocol for which the PICS applies (A.3.7). Identification of the system in which the implementation resides (A.3.3) is recommended in order to facilitate full identification of the system, and avoid possible problems during conformance testing. The client information (A.3.5) only needs to be filled in if it is relevant and different from the product supplier information.

### A.3.1 Date of statement

.....

### A.3.2 Identification of the implementation

The terms "name" and "version" should be interpreted appropriately to correspond with a suppliers terminology (e.g. Type, Series, Model).

Name of the implementation:

.....  
 .....

Implementation version:

.....  
 .....

### A.3.3 Identification of the system in which it resides

Name of the system:

.....  
.....

Hardware configuration:

.....  
.....  
.....

Operating system:

.....  
.....

### A.3.4 Product supplier

Name:

.....

Address:

.....  
.....  
.....

Telephone number:

.....

Facsimile number:

.....

E-Mail address:

.....

Additional information:

.....  
.....  
.....

### A.3.5 Client

Name:

.....

Address:

.....

.....

.....

Telephone number:

.....

Facsimile number:

.....

E-Mail address:

.....

Additional information:

.....

.....

.....

### A.3.6 PICS contact person

Name:

.....

Address:

.....

.....

.....

Telephone number:

.....

Facsimile number:

.....

E-Mail address:

.....

Additional information:

.....  
.....  
.....

### A.3.7 Protocol for which this PICS applies

Protocol:

B-QSIG-SBC - B-PISN inter-exchange signalling protocol – Separated bearer control

Protocol Version - please identify the standards document unambiguously, including e.g. reference number (ECMA-XXX), edition number (if applicable) and publication date:

.....  
.....

Corrigenda Implemented (if applicable):

.....  
.....

Addenda Implemented (if applicable):

.....  
.....

Amendments Implemented (if applicable):

.....  
.....

---

## A.4 Global Statement of Conformance

Does the implementation described in this PICS meet all the mandatory requirements of the referenced standard:

Yes

No

NOTE A.1

Answering "No" to this question indicates non-conformance to the protocol specification. In this case, an explanation shall be given of the nature of non-conformance either below or on a separate sheet of paper. Further the instructions outlined in subclause A.2.4 ("Exception Information") shall be followed when completing the PICS proforma tables.



Nature of non-conformance (if applicable):

.....

.....

.....

.....

.....

.....

.....

.....

.....

.....

.....

.....

.....

.....

.....

.....

.....

.....

.....

.....

.....

---

## A.5 Roles

The concept of roles is illustrated in subclause 8.5.2 of ISO/IEC 9646-7 [9] . For implementations, it is required to identify which roles are supported.

Roles are used in PICS proformas as predicates for the "conditions for status" column if an item is conditional upon the role(s) supported.

**Table A.1: Roles**

Item	Roles Is the implementation capable of ...	Conditions for status	Status	Reference	Support
<b>Role1</b>	functioning as a Transit PINX?		O.1		[ ]Yes [ ]No
<b>Role2</b>	functioning as a Preceding PINX with call/bearer co-ordination function?		O.1		[ ]Yes [ ]No
<b>Role3</b>	functioning as a Succeeding PINX with call/bearer co-ordination function?		O.1		[ ]Yes [ ]No
Comments:					

---

## A.6 Major capabilities

**Table A.2: Major capabilities**

Item	Major capability: Does the implementation ...	Conditions for status	Status	Reference	Support
<b>MC1</b>	support the separated bearer establishment/release ?		M	10	[ ] Yes [ ] No
Comments:					

## A.7 Subsidiary capabilities

Table A.3: Subsidiary capabilities

Item	Subsidiary capability Does the implementation...	Conditions for status	Status	Reference	Support
SC1	support procedures for bearer connection establishment at the preceding side?	Role1 OR Role2 ( Role1 OR Role2)	M N/A	10.2.1	[ ]Yes [ ]No [ ]N/A
SC2	support procedures for bearer connection establishment at the succeeding side?	Role1 OR Role3 (Role1 OR Role3)	M N/A	10.2.2	[ ]Yes [ ]No [ ]N/A
SC3	Support procedures for bearer connection establishment at the Transit PINX	Role1 (Role1)	M N/A	10.4	[ ]Yes [ ]No [ ]N/A
SC4	Support procedures for joining bearer connections on adjacent call segments	Role2 OR Role3 (Role2 OR Role3)	M N/A	10.3	[ ]Yes [ ]No [ ]N/A
SC4	support connection clearing procedures		M	10.5	[ ]Yes [ ]No
SC5	Support procedures for interworking with other networks not supporting separated bearer control	Role2 OR Role3 (Role2 OR Role3)	M N/A	11	[ ]Yes [ ]No [ ]N/A
Comments:					

## A.8 PDUs

No items requiring response.

## A.9 PDU parameters received by the succeeding side

Table A.4: Information elements in the SETUP message received by the succeeding side

Item	SETUP message received by the succeeding side: Does the implementation ...	Conditions for status	Status	Reference	Support
IES1	support the Call association information element (Note) ?		M	9.1.1.1	[ ] Yes [ ] No
IES2	support the Bearer identifier information element (Note) ?		M	9.1.1.1	[ ] Yes [ ] No
NOTE: Not applicable for the basic point-to-point combined call/bearer control protocol defined in ECMA-266 [1].					
Comments:					

## A.10 PDU parameters sent by the preceding side

Table A.5: Information elements in the SETUP message sent by the preceding side

Item	SETUP message sent by the preceding side: Does the implementation ...	Conditions for status	Status	Reference	Support
IEP1	support the Call association information element (Note) ?		M	9.1.1.1	<input type="checkbox"/> Yes <input type="checkbox"/> No
IEP2	support the Bearer identifier information element (Note) ?		M	9.1.1.1	<input type="checkbox"/> Yes <input type="checkbox"/> No
NOTE: Not applicable for the basic point-to-point combined call/bearer control protocol defined in ECMA-266 [1].					
Comments:					

## A.11 Timers

No items requiring response.

## A.12 Call states

No items requiring response.

---

## Annex B (informative): Guidelines for the use of the instruction indicator

This annex provides guidelines for the setting of the instruction indicator field in the Call association and Bearer identifier information elements. An implementation may choose to set the instruction indicator differently, depending on possible specific requirements beyond those covered explicitly within the present Document.

Recommended setting of the instruction indicator in the Call association information element:

Flag: "ignore explicit instructions"

Action indicator: "not significant".

Recommended setting of the instruction indicator in the Bearer identifier information element:

Flag: "ignore explicit instructions"

Action indicator: "not significant".

---

## History

<b>Document history</b>			
V1.1.1	February 2000	One-step Approval Procedure	OAP 200025: 2000-02-23 to 2000-06-23