

ETSI EN 301 744 V1.1.1 (2000-10)

European Standard (Telecommunications series)

**Fixed Radio Systems;
Point-to-multipoint equipment;
Direct Sequence Code Division/
Time Division Multiple Access (DS-CD/TDMA);
Point-to-multipoint digital packet radio systems
in frequency bands in the range 3 GHz to 11 GHz**



Reference

DEN/TM-04080

Keywords

CDMA, DRRS, multipoint, TDMA, transmission

ETSI

650 Route des Lucioles
F-06921 Sophia Antipolis Cedex - FRANCE

Tel.: +33 4 92 94 42 00 Fax: +33 4 93 65 47 16

Siret N° 348 623 562 00017 - NAF 742 C
Association à but non lucratif enregistrée à la
Sous-Préfecture de Grasse (06) N° 7803/88

Important notice

Individual copies of the present document can be downloaded from:

<http://www.etsi.org>

The present document may be made available in more than one electronic version or in print. In any case of existing or perceived difference in contents between such versions, the reference version is the Portable Document Format (PDF). In case of dispute, the reference shall be the printing on ETSI printers of the PDF version kept on a specific network drive within ETSI Secretariat.

Users of the present document should be aware that the document may be subject to revision or change of status. Information on the current status of this and other ETSI documents is available at <http://www.etsi.org/tb/status/>

If you find errors in the present document, send your comment to:
editor@etsi.fr

Copyright Notification

No part may be reproduced except as authorized by written permission.
The copyright and the foregoing restriction extend to reproduction in all media.

© European Telecommunications Standards Institute 2000.
All rights reserved.

Contents

Intellectual Property Rights	5
Foreword.....	5
Introduction	5
1 Scope	7
1.1 Applications	7
1.2 Frequencies.....	7
1.3 Access method.....	7
1.4 Compatibility.....	7
2 References	8
3 Definitions, symbols and abbreviations	8
3.1 Definitions	8
3.2 Symbols.....	9
3.2 Abbreviations	9
4 General system architecture	10
4.1 Sub-system types.....	10
4.2 System characteristics	11
4.2.1 Transparency.....	11
5 Radio characteristics.....	11
5.1 Frequency bands.....	11
5.2 Channel arrangement.....	11
5.2.1 System loading.....	12
5.3 Transmitter characteristics.....	12
5.3.1 Tx power range	12
5.3.1.1 Automatic Transmit Power Control (ATPC)	12
5.3.1.2 Remote Transmit Power Control (RTPC).....	12
5.3.2 Spectrum mask.....	13
5.3.3 Transmitter spurious emissions.....	13
5.3.4 Radio frequency tolerance	14
5.4 Receiver characteristics	14
5.4.1 Dynamic range.....	14
5.4.2 Broadband CW interference rejection capability	14
5.4.3 Spurious emissions	14
5.4.4 BER performance	14
5.4.4.1 Single Signal performance	14
5.4.4.2 Loaded BER performance.....	14
5.4.4.3 Maximum system loading.....	15
5.4.5 Interference sensitivity.....	15
5.4.5.1 Co-channel interference sensitivity.....	15
5.4.5.2 First offset channel interference sensitivity.....	15
5.4.5.3 Second offset channel interference sensitivity	15
5.4.5.4 Adjacent channel interference sensitivity.....	16
5.5 Antenna port characteristics	16
5.5.1 RF interface	16
5.5.2 Return loss	16
6 Types of subscriber equipment and network router interface	16
7 Power supply and environmental characteristics	17
7.1 Power supply	17
7.2 Environmental conditions.....	17
7.2.1 Equipment within weather-protected locations.....	17
7.2.2 Equipment for non weather-protected locations	17
7.3 Electromagnetic compatibility conditions	17

Bibliography18
History19

Intellectual Property Rights

IPRs essential or potentially essential to the present document may have been declared to ETSI. The information pertaining to these essential IPRs, if any, is publicly available for **ETSI members and non-members**, and can be found in ETSI SR 000 314: "*Intellectual Property Rights (IPRs); Essential, or potentially Essential, IPRs notified to ETSI in respect of ETSI standards*", which is available from the ETSI Secretariat. Latest updates are available on the ETSI Web server (<http://www.etsi.org/ipr>).

Pursuant to the ETSI IPR Policy, no investigation, including IPR searches, has been carried out by ETSI. No guarantee can be given as to the existence of other IPRs not referenced in ETSI SR 000 314 (or the updates on the ETSI Web server) which are, or may be, or may become, essential to the present document.

Foreword

This European Standard (Telecommunications series) has been produced by ETSI Technical Committee Transmission and Multiplexing (TM).

National transposition dates	
Date of adoption of this EN:	25 August 2000
Date of latest announcement of this EN (doa):	30 November 2000
Date of latest publication of new National Standard or endorsement of this EN (dop/e):	31 May 2001
Date of withdrawal of any conflicting National Standard (dow):	31 May 2001

Introduction

The main field of application of Point-to-Multipoint (P-MP) Systems is to provide access to both public and private networks (PSTN, PDN, ...). By means of P-MP systems the network service area may be extended to cover both distant and scattered subscriber locations; and the systems may be applied to build new access networks covering both urban and rural areas.

Subscribers are offered the full range of services by the particular public or private network. Subscribers have access to these services by means of a standard data port, e.g. Ethernet.

P-MP systems provide standard network interfaces and transparently connect subscribers to the appropriate network node. These systems allow a service to be connected to a number of subscribers ranging from a few users to several thousand, and over a wide range of distances.

Point-to-Multipoint systems are generally configured as Pre-Assigned Multiple Access (PAMA) Systems or as Demand-Assigned Multiple Access (DAMA) Radio Systems.

The essential features of a typical P-MP DAMA Radio Systems are:

- efficient use of the radio spectrum;
- concentration;
- and transparency.

Radio is often the ideal way of obtaining communications at low cost, almost independent of distance and difficult topography. Moreover, a small number of sites is required for these installations, thus facilitating rapid implementation and minimizing maintenance requirements of the systems.

Concentration in a packet radio system means that subscribers can share the radio resource by sequential allocation of time to each subscriber. Slowing of the system performance can be minimized by adaptive time allocation, whereby subscribers with no recent transactions are not polled as frequently as currently active subscribers.

Concentration requires the use of distributed intelligent control which in turn allows many other operation and maintenance functions to be added.

Transparency means that the exchange or router and the subscriber equipment communicate with each other without being aware of the radio link.

1 Scope

1.1 Applications

The scope of the present document covers the following typical point-to-multipoint data applications.

- Wide Area Networks.
- Internet data.
- Voice over IP.
- Data.

1.2 Frequencies

The present document covers fixed service allocations in the 3 to 11 GHz band. Bands identified by CEPT for P-MP applications between 3 and 11 GHz are:

- 3 410 MHz to 3 600 MHz [5];
- 3 600 MHz to 3 800 MHz [6]; and
- 10,15 GHz to 10,3 GHz paired with 10,5 GHz to 10,65 GHz [7].

1.3 Access method

The standard covers DS-CD/TDMA systems.

The dual definition of the access method arises from the particular features of this system, whereby multiple access is available firstly through the code division, which allows multiple carriers within the channel, and then by sequential time allocation to individual users. The multiple carriers are not co-channel, but are offset from each other by up to half the channel spacing, so packet data systems employing DS-CDMA for multiple co-channel bearers are not within the scope of the present document.

1.4 Compatibility

There shall be no requirement to operate Central Station (CS) equipment from one manufacturer with Terminal Station (TS) or Repeater Station (RS) equipment from another manufacturer.

2 References

The following documents contain provisions which, through reference in this text, constitute provisions of the present document.

- References are either specific (identified by date of publication, edition number, version number, etc.) or non-specific.
- For a specific reference, subsequent revisions do not apply.
- For a non-specific reference, the latest version applies.
- A non-specific reference to an ETS shall also be taken to refer to later versions published as an EN with the same number.

- [1] ETSI ETS 300 019: "Equipment Engineering (EE); Environmental conditions and environmental tests for telecommunications equipment".
- [2] ETSI EN 300 385: "Electromagnetic compatibility and Radio spectrum Matters (ERM); ElectroMagnetic Compatibility (EMC) standard for fixed radio links and ancillary equipment".
- [3] ETSI ETS 300 132: "Equipment Engineering (EE); Power supply interface at the input to telecommunications equipment".
- [4] ITU-R Radio Regulations - Volume 1 to 4 - Part 1: General provisions.
- [5] CEPT/ERC/Recommendation T/R 14-03: "Harmonized radio frequency channel arrangements for low and medium capacity systems in the band 3 400 MHz to 3 600 MHz".
- [6] CEPT/ERC/Recommendation T/R 12-08: "Harmonized radio frequency channel arrangements and block allocations for low, medium and high capacity systems in the band 3 600 MHz to 4 200 MHz".
- [7] CEPT/ERC/Recommendation T/R 12-05: "Harmonized radio frequency channel arrangements for digital terrestrial fixed systems operating in the band 10,0 GHz to 10,68 GHz".
- [8] CEPT/ERC/Recommendation 74-01: "Spurious emissions".
- [9] ISO/IEC 8802-3 (1996): "Information technology - Telecommunications and information exchange between systems - Local and metropolitan area networks - Specific requirements - Part 3: Carrier sense multiple access with collision detection (CSMA/CD) access method and physical layer".
- [10] ITU-T Recommendation X.21 (1992): "Interface between Data Terminal Equipment and Data Circuit-terminating Equipment for synchronous operation on public data networks".

3 Definitions, symbols and abbreviations

3.1 Definitions

For the purposes of the present document, the following terms and definitions apply:

chip: unit of modulation used in Direct Sequence Spread Spectrum modulation.

chip rate: number of chips per second e.g. Mchip/s.

chip sequence: sequence of chips with defined length and chip polarities.

direct sequence spread spectrum modulation: form of modulation whereby a combination of data to be transmitted and a fixed code sequence (chip sequence) is used to directly modulate a carrier, e.g. by phase shift keying.

single DS-CD/TDMA signal: single traffic channel and any associated signalling and synchronization overhead.

system loading: total payload data rate on a single RF channel.

maximum system loading: maximum possible payload data rate on a single RF channel.

offset channel: radio channel at a frequency other than co-channel but closer than half the adjacent channel spacing.

3.2 Symbols

For the purposes of the present document, the following symbols apply:

dB	decibel
dBm	decibels relative to one milliwatt
kbit/s	kilobits per second
Mbit/s	megabits per second

3.3 Abbreviations

For the purposes of the present document, the following abbreviations apply:

BER	Bit Error Rate
BW	Bandwidth
CCS	Central Controller Station
CRS	Central Radio Station
CS	Central Station
CW	Continuous Wave
DS-CD/TDMA	Direct Sequence Code Division/Time Division Multiple Access
PRBS	Pseudo Random Bit Sequence
RF	Radio Frequency
RS	Repeater Station
RSL	Received Signal Level
Rx	Receiver
TE	Terminal Equipment
TS	Terminal Station
Tx	Transmitter

4 General system architecture

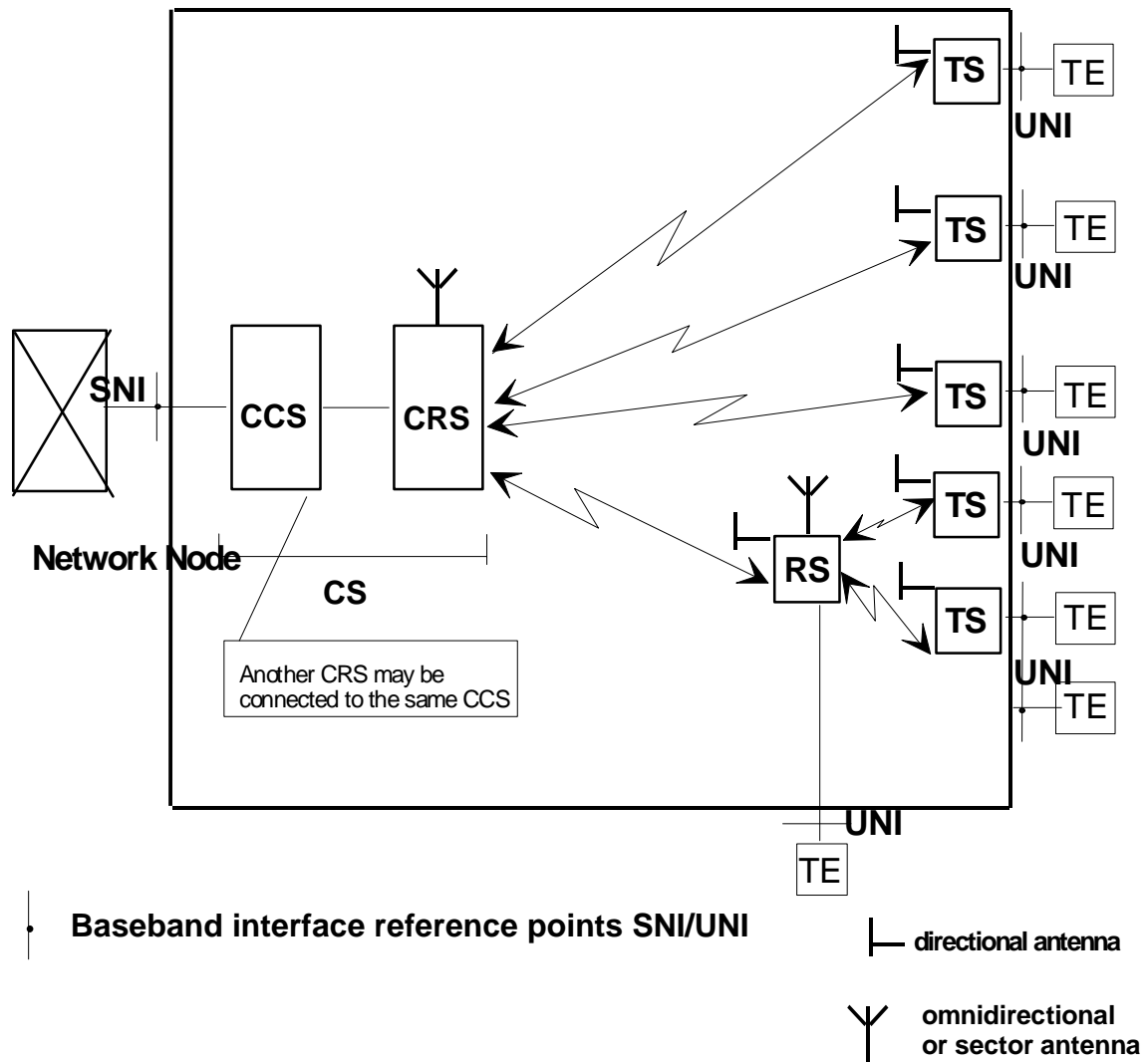

Figure 1: General System Architecture

4.1 Sub-system types

CS Central Station which may be subdivided in to two units:

CCS: Central Controller Station which provides the interface to the network node;

CRS: Central Radio Station which is the central base station containing at least the radio transceiver equipment providing the interface to the terminal station via the air. Each transceiver is connected to a separate antenna. This is used e.g. if sectored cells are applied to increase the capacity of each cell;

TS: Terminal station which provides the interfaces to the subscriber equipment;

RS: Repeater Station which may also provide the interfaces to the subscriber, if applicable. An RS may serve one or more TSs;

SNI: Service Network Interface;

UNI: User Network Interface;

TE: Terminal (Subscriber) Equipment.

NOTE 1: Central Controller Station (CCS) may control more than one Central Radio Station (CRS).

NOTE 2: A TS may serve more than one TE.

The central station performs the interconnection with the network node (local router or Ethernet switch) carrying out a concentration function by sharing the total number of available channels in the system. The central station is linked by microwave transmission paths to each Terminal Station (TS) either directly or via one or more Repeater Stations (RS).

Whenever an existing digital transmission link is available, the network implementation can be optimized by separating the CCS, installed at the exchange/router site, and the CRS.

The general characteristics which are typical for point-to-multipoint systems are considered in the present document. These characteristics have been categorized under four headings:

1. system characteristics;
2. radio characteristics;
3. types of subscriber equipment and network router interface;
4. power supply and environmental characteristics.

4.2 System characteristics

4.2.1 Transparency

The system should be fully transparent: the router and the subscriber equipment (points SNI and UNI in figure 1) communicate with each other without being aware of the radio link.

5 Radio characteristics

5.1 Frequency bands

The present document is intended to be generic and does not contain specific frequency plans. It may be applied to fixed service allocations in the range 3 GHz to 11 GHz. Bands identified by CEPT for P-MP applications between 3 GHz and 11 GHz are:

- 3 410 MHz to 3 600 MHz [5];
- 3 600 MHz to 3 800 MHz [6]; and
- 10,15 GHz to 10,3 GHz paired with 10,5 GHz to 10,65 GHz [7].

National Authorities may allocate specific bands for P-MP systems on a national / geographic basis.

5.2 Channel arrangement

In DS-CD/TDMA systems the required channel spacing is determined by the chip rate as well as the data rate. The following channel spacings have currently been identified (see table 1). Future developments may require different channel spacings.

Table 1: Channel spacing

Channel Spacing (MHz)	24,0		
-----------------------	------	--	--

Further channel spacings are available by scaling proportionally all channel-related parameters in the present document.

5.2.1 System loading

Due to particular features of the polling system used to access users, there is no limit to system loading. In practice, operational requirements will determine the maximum acceptable system loading.

5.3 Transmitter characteristics

5.3.1 Tx power range

Maximum averaged output power shall not exceed 43 dBm (27 dBm in the band 10,6 GHz to 10,65 GHz [4]) at point C' of the RF block diagram (see figure 2). For channel spacings of 10 MHz or greater, in the bands below 10,6 GHz the maximum averaged output power shall not exceed 46 dBm.

An internal or external means of adjustment shall be provided.

The transmitted output power means the value measured where the output is connected to a dummy load, e.g. power meter or spectrum analyser. The transmitter is modulated with a test data signal to simulate traffic.

NOTE: Points B & C and B' & C' will coincide if branching networks are not used.

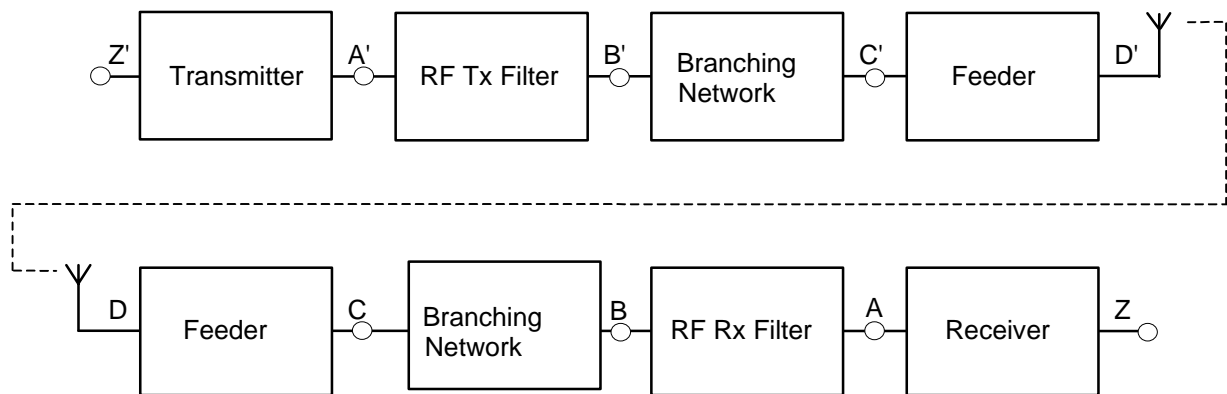

Figure 2: RF system block diagram

5.3.1.1 Automatic Transmit Power Control (ATPC)

Equipment with ATPC will be subject to manufacturer declaration of the ATPC range and related tolerances. Testing shall be carried out with output level corresponding to:

- ATPC set manually to a fixed value for system performance;
- ATPC set at maximum provided output power for Tx performance.

5.3.1.2 Remote Transmit Power Control (RTPC)

Equipment with RTPC will be subject to manufacturer declaration of the RTPC range and related tolerances. Testing shall be carried out with output level corresponding to:

- RTPC set manually to the maximum and to the minimum values for System performance;
- RTPC set at maximum provided output power for Tx performance.

RF spectrum mask will be verified at three points (lower, medium and upper part of the frequency band envisaged), if applicable.

5.3.2 Spectrum mask

The spectrum mask is given in figure 3. No allowance is made for frequency tolerance.

The transmitted output power spectrum is defined as the spectrum when modulated with a test data signal that simulates a system operating under maximum system loading conditions. In case of multiple carrier operation, each individual DS-CD/TDMA carrier is defined by the mask.

The spectrum measurement at point C' of the RF system block diagram figure 2 shall be performed with the max. hold function on the spectrum analyser selected.

The reference level of the output spectrum means that the 0 dB level is the top of the modulated spectrum, disregarding residual carrier.

Table 2: Spectrum Analyser Settings

Res. BW	Video BW	Sweep time
30 kHz	300 Hz	10 s

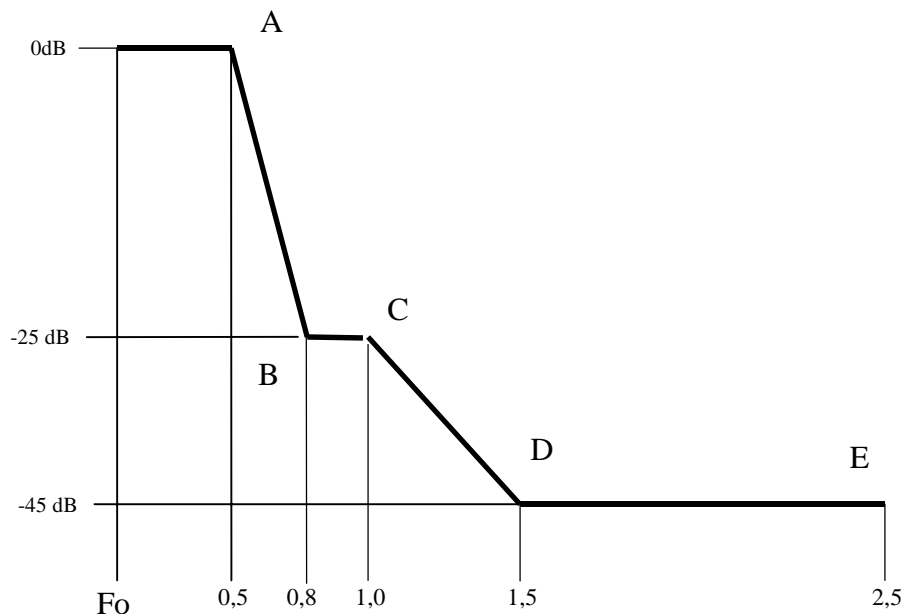

Figure 3: DS-CD/TDMA spectrum mask normalized for channel spacing

Table 3: Channel spacing against spectrum mask reference points

Relative Level→	Point A 0 dB	Point B -25 dB	Point C -25 dB	Point D -45 dB	Point E -45 dB	
Channel Spacing MHz↓	0,5 x Channel Spacing	0,8 x Channel Spacing	1,0 x Channel Spacing	1,5 x Channel Spacing	2,5 x Channel Spacing	
	24	12 MHz	19,2 MHz	24 MHz	36 MHz	60 MHz

5.3.3 Transmitter spurious emissions

Outside the frequency range $\pm 250\%$ of the relevant channel spacing, across the nominal centre frequency, CEPT/ERC Recommendation 74-01 [8] shall apply.

5.3.4 Radio frequency tolerance

Maximum radio frequency tolerance shall not exceed 20 ppm. This limit includes both short-term factors and long-term ageing effects. For the purpose of type-testing the manufacturer shall state the guaranteed short-term part and the expected ageing part.

5.4 Receiver characteristics

5.4.1 Dynamic range

Table 4 defines, for the appropriate receiver type and a single DS-CD/TDMA signal, the dynamic range above the receiver threshold level defined in table 5, for which the BER shall be 10^{-3} or less.

NOTE: The dynamic range for receivers facing terminal stations is lower because of the use of automatic transmitter power control.

Table 4: Dynamic range

Terminal Station	60 dB
Repeater Station (facing Central Station)	60 dB
Repeater Station (facing Terminal Station)	20 dB
Central Station	20 dB

5.4.2 Broadband CW interference rejection capability

For a receiver operating at the RSL specified in subclause 5.4.4.1 for 10^{-6} BER threshold, the introduction of a CW interferer at a level of +30dB with respect to the wanted signal and at any frequency up to 26 GHz, excluding frequencies either side of the wanted frequency up to 450 % of the channel spacing, shall not result in a BER greater than 10^{-5} . This is considered equivalent to a 1dB degradation of the 10^{-6} BER threshold.

5.4.3 Spurious emissions

CEPT/ERC Recommendation 74-01 [8] shall apply.

5.4.4 BER performance

5.4.4.1 Single Signal performance

For a single DS-CD/TDMA signal receiver BER thresholds (dBm) referred to point C of the RF block diagram (figure 2) for a BER of 10^{-3} and 10^{-6} shall be equal to or lower than those stated in table 5. These values do not include any contribution due to the necessary signalling and synchronization overhead.

Table 5: BER performance thresholds

User Bit Rate (kbit/s)	RSL for BER 10^{-3} (dBm)	RSL for BER 10^{-6} (dBm)
4 500	-85	-83

5.4.4.2 Loaded BER performance

Radio traffic is sequential and loading imposes no penalty upon BER threshold. The thresholds given in table 5 apply to the total bit rate.

5.4.4.3 Maximum system loading

There is no limit to the system loading. Net throughput per user is inversely proportional to loading and maximum loading is a matter of operational choice.

5.4.5 Interference sensitivity

5.4.5.1 Co-channel interference sensitivity

All receive signal levels and interference level measurements are referred to point C of the system block diagram, given in figure 2.

The limits of co-channel interference for uncorrelated, like-modulated signals shall be as in table 6.

For a signal applied to the receiver at a level greater by 1 or 3 dB than the relevant level specified in table 5 an applied additional co-channel interferer with uncorrelated, like modulation in the same bandwidth at the relevant level specified in table 6 shall not cause the BER to exceed the relevant specified figure.

Table 6: Co-channel Sensitivity

Threshold Degradation→	BER 10 ⁻⁶	
	1 dB	3 dB
Channel Spacing MHz ↓	Interference level (dBm)	Interference level (dBm)
24	-105	-103

5.4.5.2 First offset channel interference sensitivity

All receive signal levels and interference level measurements are referred to point C of the system block diagram, given in figure 2.

The limits of first offset channel interference for an uncorrelated, like-modulated signal shall be as in table 7.

Table 7: First Offset Channel Sensitivity

Threshold Degradation→	Channel Spacing MHz ↓	BER 10 ⁻⁶	
		1 dB	3 dB
Offset MHz	Interference level (dBm)	Interference level (dBm)	
5,5	-97	-95	

5.4.5.3 Second offset channel interference sensitivity

All receive signal levels and interference level measurements are referred to point C of the system block diagram, given in figure 2.

The limits of second offset channel interference for an uncorrelated, like-modulated signal shall be as in table 8.

Table 8: Second Offset Channel Sensitivity

	Threshold Degradation→	BER 10 ⁻⁶	
		1 dB	3 dB
Channel Spacing MHz ↓	Offset MHz	Interference level (dBm)	Interference level (dBm)
24	11,0	-93	-91

5.4.5.4 Adjacent channel interference sensitivity

All receive signal levels and interference level measurements are referred to point C of the system block diagram, given in figure 2.

The limits of adjacent channel interference for an uncorrelated, like-modulated signal shall be as in table 9.

Table 9: Adjacent Channel Sensitivity

	BER 10 ⁻⁶	
	1 dB	3 dB
Threshold Degradation→	Interference level (dBm)	Interference level (dBm)
Channel Spacing MHz ↓		
24	-82	-80

5.5 Antenna port characteristics

5.5.1 RF interface

For equipment without an integral antenna, the RF interface at reference points C and C' of the system block diagram, figure 2 shall be either coaxial 50 Ohms or an appropriate waveguide flange.

5.5.2 Return loss

For equipment without an integral antenna, the return loss at reference points C and C' of the RF system block diagram (figure 2) shall be more than 10 dB at the reference impedance.

6 Types of subscriber equipment and network router interface

The equipment covered by the present document shall use one or more of the standardized interfaces given in table 10.

Table 10: Types of interface

Subscriber and Network Router Equipment Interfaces	
Ethernet	ISO/IEC 8802-3 [9]
X21	[10]

Other standard data interfaces may also be implemented.

7 Power supply and environmental characteristics

7.1 Power supply

The equipment shall operate from one or more of the power supplies within the ranges specified in tables 11 and 12.

Table 11: Power Supplies - DC

Nominal voltage	Voltage range
12	10,8 to 13,6
24	21,8 to 28,1 ETS 300 132 [3]
48	40,5 to 57,0 ETS 300 132 [3]
60	50,0 to 72,0

Table 12: Power Supplies - AC

For 110 V AC nominal	99 to 121 V	60 Hz \pm 2 Hz
For 230 V AC nominal	207 to 253 V	50 Hz \pm 2 Hz ETS 300 132 [3]

7.2 Environmental conditions

The equipment shall meet the environmental conditions set out in ETS 300 019 [1] which defines weather-protected and non weather-protected location classes and test severity.

7.2.1 Equipment within weather-protected locations

Equipment intended for operation in temperature-controlled locations or partially temperature-controlled locations shall meet the requirements of ETS 300 019 [1] classes 3.1 and 3.2 respectively.

Optionally, the more stringent requirements of ETS 300 019 [1] classes 3.3 (Non temperature controlled locations), 3.4 (Sites with heat trap) and 3.5 (Sheltered locations) may be applied.

7.2.2 Equipment for non weather-protected locations

Equipment intended for operation within non weather-protected locations shall meet the requirements of ETS 300 019 [1], class 4.1 or 4.1E.

Class 4.1 applies to many ETSI countries and class 4.1E applies to all ETSI countries.

Weather-protected equipment conforming to class 3.3, 3.4 or 3.5 together with an enclosure or cabinet may fulfil the requirements for operating in a non weather-protected environment but this is outside the scope of the present document.

7.3 Electromagnetic compatibility conditions

The equipment shall operate under the conditions of EN 300 385 [2].

Bibliography

The following material, though not specifically referenced in the body of the present document (or not publicly available), gives supporting information.

- ITU-T Recommendation G.773: "Protocol suites for Q-interfaces for management of transmission systems".
- ITU-R Recommendation SM.329-7: "Spurious emissions".

History

Document history		
V1.1.1	September 1999	Public Enquiry PE 9961: 1999-09-29 to 2000-01-28
V1.1.1	June 2000	Vote V 20000825: 2000-06-26 to 2000-08-25
V1.1.1	October 2000	Publication