

ETSI EN 301 709 V8.0.1 (2000-10)

European Standard (Telecommunications series)

Digital cellular telecommunications system (Phase 2+); Link Adaptation (GSM 05.09 version 8.0.1 Release 1999)

The GSM logo consists of the letters 'GSM' in a bold, blue, sans-serif font. A small red square is positioned to the right of the 'M'. A registered trademark symbol (®) is located to the right of the 'M'.

GSM®

GLOBAL SYSTEM FOR
MOBILE COMMUNICATIONS



Reference

REN/SMG-020509Q8

Keywords

Digital cellular telecommunications system,
Global System for Mobile communications (GSM)

ETSI

650 Route des Lucioles
F-06921 Sophia Antipolis Cedex - FRANCE

Tel.: +33 4 92 94 42 00 Fax: +33 4 93 65 47 16

Siret N° 348 623 562 00017 - NAF 742 C
Association à but non lucratif enregistrée à la
Sous-Préfecture de Grasse (06) N° 7803/88

Important notice

Individual copies of the present document can be downloaded from:

<http://www.etsi.org>

The present document may be made available in more than one electronic version or in print. In any case of existing or perceived difference in contents between such versions, the reference version is the Portable Document Format (PDF). In case of dispute, the reference shall be the printing on ETSI printers of the PDF version kept on a specific network drive within ETSI Secretariat.

Users of the present document should be aware that the document may be subject to revision or change of status. Information on the current status of this and other ETSI documents is available at <http://www.etsi.org/tb/status/>

If you find errors in the present document, send your comment to:
editor@etsi.fr

Copyright Notification

No part may be reproduced except as authorized by written permission.
The copyright and the foregoing restriction extend to reproduction in all media.

© European Telecommunications Standards Institute 2000.
All rights reserved.

Contents

Intellectual Property Rights	4
Foreword.....	4
1 Scope	5
1.1 References	5
1.2 Abbreviations	5
2 General	6
3 Adaptive Multi-Rate inband control and link adaptation	6
3.1 General operation	6
3.1.1 Operation without Tandem Free Operation	6
3.1.2 Operation with ongoing Tandem Free Operation	7
3.1.3 Operation at handover with ongoing Tandem Free Operation.....	7
3.2 Inband Signalling	7
3.2.1 Frequent inband signalling for AMR codec mode adaptation	8
3.2.1.1 General aspects	8
3.2.1.2 Operation with DTX enabled	8
3.2.1.3 Transmitter/Receiver Synchronisation	8
3.2.2 Robust inband signalling for AMR configuration modification	8
3.2.2.1 General aspects	8
3.2.2.2 RATSCCH protocol	9
3.2.2.3 RATSCCH messages	10
3.2.2.3.1 ACK_OK message	10
3.2.2.3.2 ACK_ERR message	10
3.2.2.3.3 ACK_UNKNOWN message	10
3.2.2.3.4 CMI_PHASE_REQ message	10
3.2.2.3.5 AMR_CONFIG_REQ message.....	11
3.2.2.3.6 THRESH_REQ message	12
3.3 Codec mode adaptation	12
3.3.1 Channel quality measure.....	12
3.3.2 Generation of Codec Mode Commands and Requests.....	13
3.3.3 Performance requirements	13
3.3.3.1 MS response to the Codec Mode Command	13
3.3.3.2 BTS response to the Codec Mode Request	13
3.3.3.3 Performance of the Codec Mode Request Generation	13
3.4 Setup procedures	14
3.4.1 Definition of the AMR Active Codec Set.....	14
3.4.2 Definition of Codec Mode Command/Request decision thresholds	14
3.4.3 Initial Codec Mode Selection at Call Setup and Handover.....	15
Annex A (informative): Example Solution for Link quality estimation	16
Annex B (informative): Example Definition of Mode Command/Request decision thresholds	17
Annex C (informative): Principles for AMR codec mode adaptation with TFO.....	18
C.1 Downgrading.....	18
C.1.1 Uplink downgrading.....	18
C.1.2 Downlink downgrading	19
C.2 Upgrading.....	20
C.2.1 Downlink upgrading.....	20
C.2.2 Uplink upgrading.....	21
Annex D (informative): Change control history	22
History	23

Intellectual Property Rights

IPRs essential or potentially essential to the present document may have been declared to ETSI. The information pertaining to these essential IPRs, if any, is publicly available for **ETSI members and non-members**, and can be found in ETSI SR 000 314: "*Intellectual Property Rights (IPRs); Essential, or potentially Essential, IPRs notified to ETSI in respect of ETSI standards*", which is available from the ETSI Secretariat. Latest updates are available on the ETSI Web server (<http://www.etsi.org/ipr>).

Pursuant to the ETSI IPR Policy, no investigation, including IPR searches, has been carried out by ETSI. No guarantee can be given as to the existence of other IPRs not referenced in ETSI SR 000 314 (or the updates on the ETSI Web server) which are, or may be, or may become, essential to the present document.

Foreword

This European Standard (Telecommunications series) has been produced by ETSI Technical Committee Special Mobile Group (SMG).

The present document specifies the relevant procedures for link adaptation implemented in the Mobile Station (MS) and Base Station System (BSS) of the digital mobile cellular and personal communication systems operating in the 900 MHz, 1 800 MHz and 1 900 MHz band (GSM 900, DCS 1 800 and PCS 1 900).

The contents of the present document are subject to continuing work within SMG and may change following formal SMG approval. Should SMG modify the contents of the present document it will then be republished by ETSI with an identifying change of release date and an increase in version number as follows:

Version 8.x.y

where:

- 8 indicates release 1999 of GSM Phase 2+.
- x the second digit is incremented for all changes of substance, i.e. technical enhancements, corrections, updates, etc.
- y the third digit is incremented when editorial only changes have been incorporated in the specification.

National transposition dates	
Date of adoption of this EN:	1 September 2000
Date of latest announcement of this EN (doa):	31 December 2000
Date of latest publication of new National Standard or endorsement of this EN (dop/e):	30 June 2001
Date of withdrawal of any conflicting National Standard (dow):	30 June 2001

1 Scope

The requirements described in the present document are mandatory for implementation in all GSM MSs and BSSs capable of supporting the Adaptive Multi-Rate speech traffic channel, unless otherwise stated.

Unless otherwise specified, references to GSM include GSM at any frequency band.

1.1 References

The following documents contain provisions which, through reference in this text, constitute provisions of the present document.

- References are either specific (identified by date of publication, edition number, version number, etc.) or non-specific.
- For a specific reference, subsequent revisions do not apply.
- For a non-specific reference, the latest version applies.
- A non-specific reference to an ETS shall also be taken to refer to later versions published as an EN with the same number.
- For this Release 1999 document, references to GSM documents are for Release 1999 versions (version 8.x.y).

- [1] GSM 01.04: "Digital cellular telecommunications system (Phase 2+); Abbreviations and acronyms".
- [2] GSM 04.08: "Digital cellular telecommunications system (Phase 2+); Mobile radio interface layer 3 specification".
- [3] GSM 05.02: "Digital cellular telecommunications system (Phase 2+); Multiplexing and multiple access on the radio path".
- [4] GSM 05.03: "Digital cellular telecommunications system (Phase 2+); Channel Coding".
- [5] GSM 05.05: "Digital cellular telecommunications system (Phase 2+); Radio transmission and reception".
- [6] GSM 08.08: "Digital cellular telecommunications system (Phase 2+); Mobile-services Switching Centre - Base Station System (MSC - BSS) interface, Layer 3 specification".
- [7] GSM 08.62: "Digital cellular telecommunications system; Inband Tandem Free Operation (TFO) of Speech Codecs".

1.2 Abbreviations

For the purposes of the present document, the following abbreviations apply. Further GSM related abbreviations are listed in GSM 01.04.

AMR	Adaptive Multi-Rate
ACS	Active Codec Set
CMC	Codec Mode Command
CMI	Codec Mode Indication
CMR	Codec Mode Request
ICM	Initial Codec Mode
RATSCCH	Robust AMR Traffic Synchronized Control Channel

2 General

The present document gives the detailed requirements for the correct operation of in call service specific link adaptation and control for GSM services implemented in GSM Mobile Stations (MS)s and Base Station Systems (BSS)s.

For the Adaptive Multi-Rate (AMR) speech service, the detailed description and requirements for the associated inband signaling, AMR codec mode adaptation, and AMR codec configuration are given.

An inband signaling channel is defined for AMR which enables the MS and the BTS to exchange messages on applied or requested speech and channel codec modes. Codec mode adaptation for AMR is based on received channel quality estimation in both MS and BTS, followed by a decision on the most appropriate speech and channel codec mode to apply at a given time.

The overall operation of AMR, in terms of used codec modes as well as general adaptation behaviour is controlled by the network.

3 Adaptive Multi-Rate inband control and link adaptation

3.1 General operation

3.1.1 Operation without Tandem Free Operation

A high-level block diagram of the complete AMR system is depicted in figure 1. The system consists of the major components TRAU and BTS on the network side and the MS. On the network side, speech encoder (SPE) and channel encoder (CHE) as well as channel decoder (CHD) and speech decoder (SPD) are connected via the serial A-bis interface. For each link, quality information is derived by estimating the current channel state. Based on the channel state, and also taking into consideration possible constraints from network control, the codec mode control, which is located on the network side, selects the codec modes to be applied.

The channel mode to use (TCH/AFS or TCH/AHS) is controlled by the network. Uplink and downlink always apply the same channel mode.

For codec mode adaptation the receiving side performs link quality measurements of the incoming link. The measurements are processed yielding a Quality Indicator. For uplink adaptation, the Quality Indicator is directly fed into the UL mode control unit. This unit compares the Quality Indicator with certain thresholds and generates, also considering possible constraints from network control, a Codec Mode Command indicating the codec mode to be used on the uplink. The Codec Mode Command is then transmitted inband to the mobile side where the incoming speech signal is encoded in the corresponding codec mode. For downlink adaptation, the DL Mode Request Generator within the mobile compares the DL Quality indicator with certain thresholds and generates a Codec Mode Request indicating the preferred codec mode for the downlink. The Codec Mode Request is transmitted inband to the network side where it is fed into the DL Mode Control unit. This unit generally grants the requested mode. However, considering possible constraints from network control, it may also override the request. The resulting codec mode is then applied for encoding of the incoming speech signal in downlink direction. Both for uplink and downlink, the presently applied codec mode is transmitted inband as Codec Mode Indication together with the coded speech data. At the decoder, the Codec Mode Indication is decoded and applied for decoding of the received speech data.

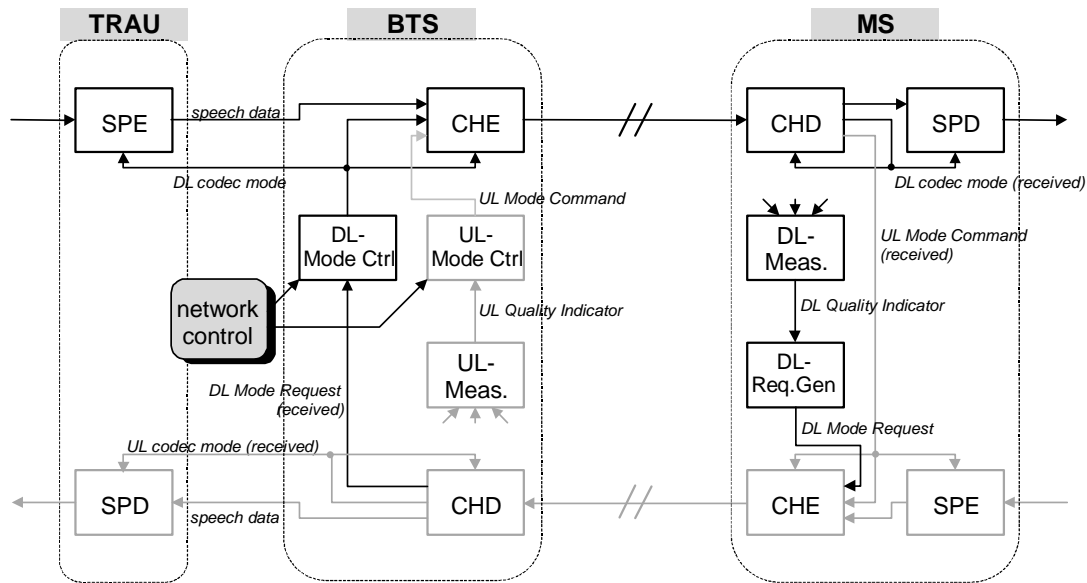

Figure 1: High level AMR block diagram

Codec mode selection is done from a set of codec modes (ACS, Active Codec Set), which may include 1 to 4 AMR codec modes. Associated with this set is a list of 1 to 3 switching thresholds and hysteresises used by the DL Mode Request Generator and the UL mode control unit to generate the Codec Mode Requests and Codec Mode Commands. These configuration parameters (ACS, thresholds, hysteresises) are defined at call setup and can be modified at handover or during a call.

3.1.2 Operation with ongoing Tandem Free Operation

If tandem free operation is ongoing (see GSM 08.62) then the speech signal has to be transmitted over two radio links, first uplink (MS1 to BTS1) and then downlink (BTS2 to MS2), respectively symmetrically in the reverse direction. The optimal Codec Mode in direction MS1 to MS2 shall be derived from the Codec Mode Request for the first uplink (CMC1, within BTS1) and the Codec Mode Request derived for the second downlink (CMR2 within MS2) in the following way: MS2 shall send the CMR2 back to BTS2 in the usual way. BTS2 shall either accept this CMR2 (default) or may modify it according to network control needs: CMR2'. Then BTS2 shall send the CMR2' further uplink to its TRAU2, to TRAU1 and downlink to BTS1 (see GSM 08.62 on how this transmission shall be handled on Abis and A interfaces). BTS1 combines the received CMR2' with its own derived CMC1 by taking the minimum of both values. If needed, BTS1 may modify this minimum value according to own network control (--> CMC1'') and shall send it finally downlink to MS1 as CMC. The identical procedure shall be performed in the reverse direction. Annex C gives an informative description.

3.1.3 Operation at handover with ongoing Tandem Free Operation

Before and during an handover at one or both sides of the MS-to-MS connection, it may be needed to freeze the codec mode adaptation for a short while, e.g. to optimise the common Active Codec Set, or to allow fast (re-)synchronisation between BTS and TRAU or to optimise the CMI Phase in downlink. Both BTSs may therefore enable or disable the codec mode adaptation (see GSM 08.62). As long as the codec mode adaptation is frozen to a specific codec mode, then this codec mode shall be used in both directions as long as tandem free operation is ongoing, or tandem free operation shall be discontinued. The Codec Mode Requests from the MSs may be taken into account to decide whether to continue TFO or not, but not for codec mode adaptation.

3.2 Inband Signalling

The AMR inband signalling consists of two parts:

- Frequent signalling, used for Codec Mode Indication and Codec Mode Command/Request.
- Robust, less frequent signalling, based on frame stealing, used for changing the AMR configuration (RATSCCH).

3.2.1 Frequent inband signalling for AMR codec mode adaptation

3.2.1.1 General aspects

The codec mode information, which has to be transmitted on each link, consists of Codec Mode Indications and Codec Mode Commands in the downlink, respectively Codec Mode Indications and Codec Mode Requests in the uplink. Codec Mode Indications inform the receiver about the currently applied codec mode. Codec Mode Commands inform the other end about the codec mode to be applied on the other link. Codec Mode Requests inform the other end about the preferred codec mode on the other link.

Codec mode information is transmitted inband in the speech traffic channel, using a part of its transmission capacity. The coding of codec modes in the inband signalling is given in subclause 3.4.1. Channel coding of codec mode information is specified in GSM 05.03 [4] for all frame types.

Codec modes are constrained to change only every second speech frame. Codec Mode Commands/Requests and Codec Mode Indications are sub-sampled such that they occur only every second frame. Codec Mode Indications and Codec Mode Commands/Requests shall be transmitted alternating within consecutive speech frames.

Both, Codec Mode Indication and Codec Mode Command/Request, shall be transmitted together within every RATSCCH frame.

3.2.1.2 Operation with DTX enabled

For SID_FIRST frames, the Codec Mode Indication or Codec Mode Command/Request in phase with the alternating transmission shall be transmitted (same phase as in speech frames).

Both, Codec Mode Indication and Codec Mode Command/Request, shall be transmitted together in every SID_UPDATE frame (as in RATSCCH frames).

For ONSET frames the Codec Mode Indication for the subsequent speech frame shall be transmitted, regardless of the phase of the inband signalling. The general phase of the inband signalling shall not be changed by that.

3.2.1.3 Transmitter/Receiver Synchronisation

The alternating transmission of the codec mode information requires synchronisation of transmitting and receiving ends, such that Codec Mode Indications and Codec Mode Commands/Requests are decoded in correct order. To ensure proper synchronisation, the codec mode information shall be transmitted aligned to the (SACCH) multi-frame structure of the GSM system.

For TCH/AFS, the default transmission phase shall be such that Codec Mode Indications are sent aligned with TDMA frame 0 in the uplink and with TDMA frame 4 in the downlink as defined in GSM 05.02 [3]. For TCH/AHS, the default transmission phase shall be such that Mode Indications are sent aligned with TDMA frame 0 or 1 depending on the subchannel in the uplink and with TDMA frame 4 or 5 depending on the subchannel, in the downlink, as defined in GSM 05.02 [3].

This default phase of the Codec Mode Indication in downlink direction is called "odd", the alternative phase, one speech frame shifted, is called "even". The phase in uplink is always the same and is never changed.

At call setup and after every handover the default phase (odd) shall be used in downlink direction. During a call, the phase of Codec Mode Indication may be changed in downlink by using a RATSCCH message. In case of handover failure and fall back to the BTS before the handover attempt, the phase before the handover attempt shall be used again.

3.2.2 Robust inband signalling for AMR configuration modification

3.2.2.1 General aspects

The RATSCCH mechanism may be used in case of Tandem Free Operation to modify the AMR Configuration on the radio interface without interruption of the speech transmission. Its application for TFO is described in GSM 08.62. This recommendation defines the RATSCCH protocol and the RATSCCH messages. The channel coding is defined in GSM 05.03 and the receiver performance in GSM 05.05. RATSCCH handling is mandatory for MS and optional for BTS.

RATSCCH is based on frame stealing. On TCH/AFS, one speech frame is stolen for each RATSCCH message, and on TCH/AHS two speech frames are stolen. In TCH/AHS RATSCCH is mapped onto two consecutive speech frames, the RATSCCH_MARKER and the RATSCCH_DATA. Both shall be sent always as one pair.

FACCH frames have higher priority than RATSCCH frames. If FACCH and RATSCCH are scheduled for transmission for the same speech frame, then the FACCH shall be sent first, followed by the RATSCCH. If the RATSCCH is delayed due to FACCH, then the appropriate counters (see 3.2.2.2) shall also be started one (TCH/AFS) respectively two (TCH/AHS) frames later. If in the case of TCH/AHS, FACCH steals the second frame of one RATSCCH message (RATSCCH_DATA), the complete RATSCCH message (RATSCCH_MARKER and RATSCCH_DATA) shall be sent following the FACCH frame.

3.2.2.2 RATSCCH protocol

The RATSCCH protocol elements consist of a number of REQuest Messages and three ACKnowledgement Messages. One information exchange consists typically of one REQ-ACK cycle between the "Initiator" and the "Addressee". While the Initiator is waiting for an ACK, it shall not send any new REQ message, i.e. transmission and acknowledgement of one REQ-ACK cycle shall be completed before the next cycle is started. ACK messages, as reaction to received REQ messages, shall always be sent back as soon as possible, and latest within 3 speech frames. Both sides shall continuously monitor the radio reception for the RATSCCH pattern and decode the RATSCCH message.

The typical REQ-ACK cycle is defined as:

- 1) If one side ("Initiator") wants to initiate the information exchange, it shall send the desired REQ message. At the same time the Initiator shall start two counters:
ACK_Timeout that shall count the elapsed speech frames (after REQ) in receive direction and
REQ_Activation that shall count the elapsed speech frames after REQ in send direction.
- 2) If the REQ message was decoded error-free (by CRC check, see GSM 05.03 [4]) and is defined (see subclause 3.2.2.3) at receiver side ("Addressee"), then the Addressee shall send an ACK_OK message back. At the same time the Addressee shall start (or restart) two own counters:
REQ_Activation that shall count the elapsed speech frames after REQ in receive direction and
ACK_Activation that shall count the elapsed speech frames after ACK in send direction.
- 3) If the Initiator receives an ACK_OK, then it shall ignore its ACK_Timeout counter and shall start an ACK_Activation counter instead that shall count the elapsed speech frames after ACK_OK in receive direction.
- 4) The contents of the REQ messages shall become valid in the direction from Initiator to Addressee exactly in that frame, where the REQ_Activation counters reach the value 12 and for all following frames.
The contents of the REQ message shall become valid in the direction from Addressee to Initiator exactly in that frame, where the ACK_Activation counters reach the value 12 and for the following frames.

NOTE: Due to the transmission delay and the reaction time within the Addressee (REQ to ACK) the activation takes place in general at four different points in time, but exactly synchronised and defined in both directions.

Error Handling:

- 1) If the REQ message was decoded error-free (no CRC error), but the message is not defined at the Addressee side, then the Addressee shall send an ACK_UNKNOWN message back. No counters are needed in this case. The Initiator, when receiving this ACK_UNKNOWN message shall terminate the exchange for this type of REQ message.
- 2) If the RATSCCH message was detected, but could not be decoded correctly (CRC failure), or its contents was not consistent, then the Addressee shall send an ACK_ERR message back. No counters are needed in this case.
- 3) If the Initiator does not receive an ACK_OK or ACK_UNKNOWN before the ACK_Timeout counter reaches 10, or it receives an ACK_ERR instead, then it shall initiate the exchange again by resending the REQ and starting the timers anew.
- 4) If the Initiator has sent the REQ unsuccessfully for three times, the retransmission shall be stopped.
- 5) If at either side an ACK_ERR or ACK_UNKNOWN is received although no corresponding REQ has been sent before, this ACK messages shall be ignored.

If the BTS receives an ACK_OK although it has not sent a corresponding REQ before, then the BTS shall initiate the sending of the used AMR Configuration down to the MS.

3.2.2.3 RATSCCH messages

Each RATSCCH message consists of its RATSCCH message identifier and potentially message parameters. In total 35 net bits are available for each message. They are numbered 34...0 in the message descriptions below, and correspond to d(34) ... d(0) in GSM 05.03. Three different ACKnowledgement message are defined.

3.2.2.3.1 ACK_OK message

The ACK_OK message serves as an acknowledgement that a RATSCCH REQ message has been detected, correctly decoded (no CRC error) and that it is defined for the Addressee. It defines the exact activation time in direction from Addressee to Initiator. Table 3.2.2.3.1 shows the definition of the ACK_OK.

Table 3.2.2.3.1: Definition of the ACK_OK message

Bit	34 ... 2 1 0
Value	0 ... 0 0 1

3.2.2.3.2 ACK_ERR message

The ACK_ERR message serves as a negative acknowledgement that a RATSCCH REQ message has been detected, i.e. the RATSCCH pattern was detected, but could not be decoded correctly (CRC error). Table 3.2.2.3.2 shows the definition of the ACK_ERR.

Table 3.2.2.3.2: Definition of the ACK_ERR message

Bit	34 ... 2 1 0
Value	0 ... 0 1 0

3.2.2.3.3 ACK_UNKNOWN message

The ACK_UNKNOWN message serves as an acknowledgement that a RATSCCH REQ message has been detected and correctly decoded, but was unknown to the Addressee. Table 3.2.2.3.3 shows the definition of the ACK_UNKNOWN.

Table 3.2.2.3.3: Definition of the ACK_UNKNOWN message

Bit	34 ... 2 1 0
Value	0 ... 0 1 1

ACKnowledge messages shall only be sent in response to a REQuest message.

3.2.2.3.4 CMI_PHASE_REQ message

The CMI_PHASE_REQ message may be sent by the BTS to change the phase of the Codec Mode Indication in downlink. CMI_PHASE_REQ has only parameter, Codec Mode Indication Phase (CMIP). Table 3.2.2.3.4a shows the format.

Table 3.2.2.3.4a: Format of the CMI_PHASE_REQ message

Bit	34 ... 2 1	0
Value	0 ... 1 0	CMIP

Assuming the CMI_PHASE_REQ message replaces DL speech frame N (frames $N-1$ and N for TCH/AHS), then the new phase shall be used starting with DL speech frame $N+12$. The CMI Phase in uplink shall not be affected. The new CMI phase in downlink shall be active until it is modified by a new CMI_PHASE_REQ or until a handover is successfully executed.

Table 3.2.2.3.6b shows how Codec Mode Indications and Codec Mode Commands shall be transmitted in even and odd speech frames depending on the value of MIP. See subclause 3.2.1.4 for the definition of even and odd speech frames.

Table 3.2.2.3.4b: Phase of Codec Mode Indication/Command in DL depending on CMIP

Value of CMIP	Information transmitted in even speech frames	Information transmitted in odd speech frames
0	Codec Mode Indication	Codec Mode Command
1 (default)	Codec Mode Command	Codec Mode Indication

3.2.2.3.5 AMR_CONFIG_REQ message

The AMR_CONFIG_REQ message may be sent by the BTS during a call to change the AMR configuration on the radio interface without interruption of the speech transmission. AMR_CONFIG_REQ contains several parameters: Active Codec Set (ACS), Initial Codec Mode (ICM), some pairs of threshold and hysteresis values (THRESH $_j$ and HYST $_j$) and two flags indicating whether the configuration parameters shall be valid for the uplink (UL), downlink (DL), or both. Table 3.2.2.3.4 shows the format.

Table 3.2.2.3.5a: Main Format of the AMR_CONFIG_REQ message

Bit	34...32	31	30	29 ... 28	27 ... 20	19 ... 16	15 ... 10	9 ... 6	5 ... 0
Value	0 0 1	DLF	ULF	ICM	ACS	HYST2	THRESH2	HYST1	THRESH1

The ACS and ICM parameters are coded in the same way as defined in GSM 04.08 [2].

All threshold and hysteresis parameters in the AMR_CONFIG_REQ are valid only for downlink direction. The coding of these parameters is given in subclause 3.4.2.

If the ACS consists of n modes ($n=1,2,3$), then only THRESH1...THRESH $n-1$ and HYST1...HYST $n-1$ are defined. The remaining bits are reserved for future use and shall be set to "1".

If the ACS consists of four modes, then the complete set of thresholds/hysteresises can not be sent with this message. In that case, all THRESH $_j$ and HYST $_j$ fields are reserved for future use and shall be set to "1". Similar, if the BTS has no threshold and hysteresis parameters for the given configuration, then all THRESH $_j$ and HYST $_j$ field bits shall be set to "1" to indicate that they are undefined. The THRESH_REQ message shall be used to transmit these parameters at a later point in time. As long as the MS has no defined threshold and hysteresis parameters it shall use the Initial Codec Mode for the Codec Mode Request.

Alternatively, in case of four codec modes, the BTS may send the three threshold and hysteresis parameters as shown in table 3.2.2.3.5.b. The coding of HYST $_c$ is given in subclause 3.4.2. All three hysteresis values (HYST1/2/3) are in that case represented by one common HYST $_c$ value (HYST1 = HYST2 = HYST3 = HYST $_c$).

Table 3.2.2.3.5b: Alternative Format of the AMR_CONFIG_REQ message for four modes

Bit	34...32	31	30	29 ... 28	27 ... 20	19 ... 18	17 ... 12	11 ... 6	5 ... 0
Value	0 0 1	DLF	ULF	ICM	ACS	HYST $_c$	THRESH3	THRESH2	THRESH1

In this way the ACS and the associated thresholds may be sent in one single message, allowing an immediate Codec Mode Request generation within the MS for the new configuration. If needed the hysteresis parameters may be modified in a later THRESH_REQ message.

The DLF and/or ULF flags are set to "1", if the configuration shall apply to the respective link (DL or UL).

Three different cases are possible when this AMR_CONFIG_REQ message is sent:

- 1) DLF is set to "1", ULF is set to "0":
Assuming the AMR_CONFIG_REQ message replaces DL speech frame N (speech frames $N-1$ and N for TCH/AHS), then the BTS and MS shall use the new ACS and ICM starting with DL speech frame $N+12$. This means that from that speech frame on, Mode Commands and Mode Indications on the DL shall be interpreted relative to the new ACS. The Configuration in the UL direction is not affected.
- 2) ULF is set to "1", DLF is set to "0":
Assuming the ACK_OK to the AMR_CONFIG_REQ message replaces UL speech frame M (speech frames $M-1$ and M for TCH/AHS), then the BTS and MS shall use the new ACS and ICM starting with UL speech frame $M+12$. This means that from that speech frame on, Mode Commands and Mode Indications on the UL shall be interpreted relative to the new ACS. The Configuration in the DL direction is not affected.
- 3) Both, DLF and ULF are set to "1":
Actions described under point 1 and 2 occur in parallel and the Configuration shall become active in both directions.

The AMR_CONFIG_REQ message with both DLF and ULF set to "0" is not defined and reserved for future use.

NOTE: During a short time in the transition period the configuration is different in uplink and downlink direction.

3.2.2.3.6 THRESH_REQ message

The THRESH_REQ message may be sent by the BTS to change the thresholds in the DL Mode Request Generator. The THRESH_REQ message contains up to three pairs of threshold and hysteresis values (THRESH $_j$ and HYST $_j$).

Table 3.2.2.3.5 shows the format.

Table 3.2.2.3.6: Format of the THRESH_REQ message

Bit	34...30	29 ... 26	25 ... 20	19 ... 16	15 ... 10	9 ... 6	5 ... 0
Value	0 0 0 0 1	HYST3	THRESH3	HYST2	THRESH2	HYST1	THRESH1

The coding of the THRESH $_j$ and HYST $_j$ values is given in section 3.4.2. If the ACS consists of n ($n=1,2,3,4$) modes, only THRESH $_1$...THRESH $_{n-1}$ and HYST $_1$...HYST $_{n-1}$ are defined. The remaining THRESH $_j$ and HYST $_j$ fields are reserved for future use and shall be set to "1".

New threshold and hysteresis parameters shall be applied in the next possible Codec Mode Request decision.

3.3 Codec mode adaptation

3.3.1 Channel quality measure

Codec mode adaptation is based on a normalized, one-dimensional measure of the channel quality, called the Quality Indicator. For reference purposes, the Quality Indicator is defined as an equivalent carrier to interferer ratio, C/I_{norm} . The MS and BSSs shall continuously update the Quality Indicator estimates.

The Quality Indicator may be derived from an estimate of the current carrier to interferer ratio, C/I_{est} , or an estimate of the current raw bit error rate (BER_{est}). A fixed normalization factor may be applied between the estimate (C/I_{est} or BER_{est}) and the Quality Indicator to compensate for higher receiver performance.

A second normalization factor should be applied to normalize the estimate with respect to different channel types, such that, with given C/I_{norm} and given codec mode, the FER after channel decoding becomes independent of the channel type. An example of channel quality measuring for the case of an Ideal Frequency Hopping channel in a Typical Urban Environment is given in annex A.

3.3.2 Generation of Codec Mode Commands and Requests

For codec mode adaptation, the channel Quality Indicators are mapped to Codec Mode Commands/Requests, by quantizing the Quality Indicators. The output values of the quantizer shall represent the different codec modes.

Hysteresis in the mapping from Quality Indicators to Codec Mode Commands/Requests should be used to prevent undesirable fast switching of CodecMode Commands/Requests. The hysteresis in the mapping is defined in the following way. The previously sent Codec Mode Command, CMC' (respectively Codec Mode Request, CMR') is used as the current state of the adaptation logic. For each state, lower and upper thresholds THR_MC_Dn(CMC') and THR_MC_Up(CMC') for the downlink, and THR_MR_Dn(CMR') and THR_MR_Up(CMR') for the uplink are defined. If the measure falls below the lower threshold, the next lower Codec Mode Command/Request commanding/requesting a more robust codec mode shall be generated. If the measure exceeds the upper threshold, then the next higher Codec Mode Command/Request commanding/requesting a less robust codec mode shall be issued. Otherwise, the previous Codec Mode Command/Request shall be repeated.

The degree of hysteresis is controlled by appropriately setting the upper and lower decision thresholds. The thresholds shall be defined by layer 3 signaling, as described in subclause 3.4.2, or by RATSCCH messages. An example of decision thresholds for the case of an Ideal Frequency Hopping channel in a Typical Urban Environment is given in annex B.

For reasons of channel error robustness of the codec mode information, both Codec Mode Commands and Requests shall be restricted to change at maximum to their nearest neighbours within the Active Codec Set. This means that mode switches to modes that are not direct neighbours to the previously transmitted mode shall be avoided. Exceptions may occur at handover and when the AMR configuration is changed by an AMR_CONFIG_REQ message.

3.3.3 Performance requirements

3.3.3.1 MS response to the Codec Mode Command

The MS shall after the reception of a Codec Mode Command apply the corresponding codec mode in uplink direction for the next possible speech frame and, and no more than three speech frames later. This shall be independent of the fact that TFO is ongoing or not. If the Codec Mode Command would require a change of the uplink codec mode by more than one step within the defined Active Codec Set, then the MS shall perform the transition from the currently used codec mode into the commanded codec mode in several steps, one step every second speech frame. Exceptions may occur only at call setup and after handover, (where the MS shall start with the Initial Codec Mode, regardless, which codec mode was used before), and when the AMR configuration is modified with an AMR_CONFIG_REQ message.

3.3.3.2 BTS response to the Codec Mode Request

The BTS should apply the requested mode for the earliest possible speech frame, unless the BTS intends to override the Codec Mode Request from the MS due to network control needs.

3.3.3.3 Performance of the Codec Mode Request Generation

For TU50 channel conditions with ideal frequency hopping without DTX activated, the MS shall produce Codec Mode Requests with the following accuracy:

- When a carrier to interferer ratio 4 dB higher than a defined upper threshold is applied to the antenna connector, the MS shall request a higher mode with a probability exceeding 90%. This shall be measured immediately after a settling-time of 200 ms.
- When a carrier to interferer ratio 4 dB lower than a defined lower threshold is applied to the antenna connector, the MS shall request a lower mode with a probability exceeding 90%. This shall be measured immediately after a settling-time of 200 ms.

3.4 Setup procedures

3.4.1 Definition of the AMR Active Codec Set

AMR codec mode adaptation is done within a set of up to four codec modes. The codec mode set (Active Codec Set) to be used by the BSS and the MS is defined during call setup and/or handover by layer 3 signalling defined in GSM 04.08 [2]. The Active Codec Set (ACS) can be changed during a call using a RATSCCH message.

The following convention (see table 3.4.1) applies for the coding of the codec modes for the inband signalling (Codec Mode Indications, Codec Mode Commands/ Requests).

Table 3.4.1: Identification of the codec modes within the Active Codec Set

Identifier	Legend
CODEC_MODE_1	Represents the lowest codec mode (lowest bit-rate) of the ACS
CODEC_MODE_2	Represents the second lowest mode, if the ACS includes more than one mode
CODEC_MODE_3	Represents the third lowest mode, if the ACS includes more than two modes
CODEC_MODE_4	Represents the highest mode, if the ACS includes four modes

If less than four Codec Modes are defined in the ACS, the unused codec Mode Indications and Mode Commands/Mode Requests shall not be signalled. Unused codec modes shall not be detected by the inband signalling decoder.

3.4.2 Definition of Codec Mode Command/Request decision thresholds

The Codec Mode Command/Request decision thresholds shall be defined at call setup and/or handover by layer 3 signalling as defined in GSM 04.08 [2]. The decision thresholds may be changed during a call using a RATSCCH message. For each pair of neighbouring codec modes in the Active Codec Set, a threshold and a hysteresis value in terms of normalized carrier to interference ratio (C/I_{norm}), is defined. The lower decision threshold for switching from mode j to mode $j-1$ is given by the signalled threshold. The threshold is referred to as $THR_MC_Dn(j)$ or, $THR_MR_Dn(j)$ in subclause 3.3.2.

The sum of the signalled threshold and hysteresis constitutes the upper threshold between the codec modes, referred to as $THR_MC_Up(j-1)$ or, $THR_MR_Up(j-1)$. Figure 2 illustrates the definition of the decision thresholds, and the operational range of the Codec Modes.

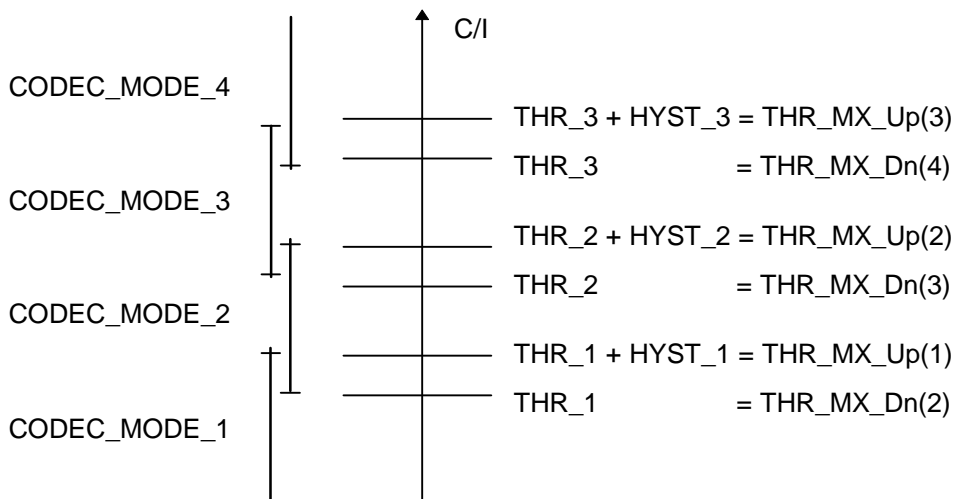

Figure 2: Definition of Threshold and Hysteresis for codec mode adaptation

The switching thresholds shall be given by the network in a consistent order, i.e. such that:

- $THR_1 \leq THR_2 \leq THR_3$, and
- $THR_1 + HYST_1 \leq THR_2 + HYST_2 \leq THR_3 + HYST_3$.

Parameter name	Description	Range	Bits
THR_1/2/3	Lower thresholds for switching between between mode j and j-1	0-63	6
HYST_1/2/3	Hysteresis values to obtain the higher thresholds for switching between mode j and j+1	0-15	4

A threshold (THR) is given as an absolute value in 0.5 dB steps. The THR values between 0 and 63 shall be mapped to normalized C/I values as follows:

THR 1/2/3	0	=	0.0 dB
THR 1/2/3	1	=	0.5 dB
THR 1/2/3	2	=	1.0 dB
	:		
	:		
THR 1/2/3	62	=	31.0 dB
THR 1/2/3	63	=	31.5 dB

NOTE: The threshold for codec mode j should be set to such a normalized C/I value that codec mode j starts to degrade and that a FER of less than 1% is observed.

When using the RATSCCH format defined by table 3.2.2.3.5a or table 3.2.2.3.6 or when using layer 3 signalling for the definition of the threshold and hysteresis parameters, the HYST1/2/3 shall be coded in 0,5 dB steps as follows:

HYST 1/2/3	0	=	0.0 dB
HYST 1/2/3	1	=	0.5 dB
HYST 1/2/3	2	=	1.0 dB
	:		
	:		
HYST 1/2/3	14	=	7.0 dB
HYST 1/2/3	15	=	7.5 dB

When using the RATSCCH format defined by table 3.2.2.3.5b for the definition of the threshold and hysteresis parameters, HYSTC shall be coded in 1 dB steps as follows:

HYSTc	0	=	1.0 dB
HYSTc	1	=	2.0 dB
HYSTc	2	=	3.0 dB
HYSTc	3	=	4.0 dB

3.4.3 Initial Codec Mode Selection at Call Setup and Handover

The Initial Codec Mode (ICM), to start the speech coding operation with at call setup and after handover may be signalled by layer 3 signalling. It may also be signalled by a RATSCCH message. This explicitly signalled ICM shall have preference over the default ICM, as describe below:

If the Initial Codec Mode is not signalled, then the default Initial Codec Mode is given by the following implicit rule. If the Active Codec Set contains:

- 1 mode, then this shall be the Initial Codec Mode;
- 2 or 3 modes, then the Initial Codec mode shall be the most robust mode of the set (with lowest bit rate);
- 4 modes, then the Initial Codec Mode shall be the second most robust mode of the set (with second lowest bit rate. If the Active Codec Set is changed during the call, then this default Initial Codec Mode shall used until an other ICM is explicitly signalled.

Annex A (informative): Example Solution for Link quality estimation

Link adaptation is based on a normalized measure C/I_{norm} of the carrier to interferer ratio. This measure is composed of an estimate of the actual carrier to interferer ratio C/I_{est} (or equivalently the actual C/N). For ideal FH-hopping channels in a typical urban environment no further adjustment or normalization is required, as described in section 3.3.1.

C/I estimates are derived by taking C and I measurements burst by burst from the equaliser algorithm. Intermediate processing results of the equaliser are estimates of the “useful” received signal and the received noise or interference signal. Taking the ratio of the energies of both signals gives a C/I estimate for the present burst.

The further processing of the burst-wise C/I estimates is as follows:

- The C/I estimates are converted to dB.
- Then FIR filtering is done with non-adaptive filters of order 100 for FR and 50 for HR channels (Filter coefficients are given in Table 1 and Table 2, which is read left to right line by line). The purpose of the filter is smoothing and prediction such that the filter output is an estimate of the expected C/I at the time instant for which the link adaptation operation, i.e. the codec mode selection, becomes effective.

Table 1: Filter coefficients of C/I measuring filter for TCH/AFS

0.02737	0.02692	0.02643	0.02573	0.02527	0.02499	0.02448	0.02393	0.02335	0.02286
0.02240	0.02203	0.02158	0.02106	0.02072	0.02032	0.01993	0.01956	0.01923	0.01877
0.01825	0.01782	0.01743	0.01715	0.01682	0.01642	0.01614	0.01566	0.01520	0.01489
0.01465	0.01422	0.01382	0.01340	0.01303	0.01273	0.01236	0.01205	0.01178	0.01141
0.01102	0.01068	0.01031	0.00998	0.00958	0.00928	0.00909	0.00882	0.00854	0.00827
0.00800	0.00784	0.00757	0.00729	0.00693	0.00659	0.00629	0.00601	0.00586	0.00565
0.00540	0.00510	0.00491	0.00473	0.00464	0.00443	0.00424	0.00397	0.00385	0.00360
0.00351	0.00311	0.00290	0.00269	0.00232	0.00204	0.00180	0.00165	0.00137	0.00119
0.00098	0.00073	0.00052	0.00031	0.00006	-0.00018	-0.00027	-0.00034	-0.00043	-0.00064
-0.00079	-0.00104	-0.00107	-0.00122	-0.00146	-0.00162	-0.00183	-0.00195	-0.00208	-0.00232
-0.00253									

Table 2: Filter coefficients of C/I measuring filter for TCH/AHS

0.03998	0.03903	0.03781	0.03650	0.03513	0.03406	0.03296	0.03223	0.03116	0.03036
0.02911	0.02832	0.02756	0.02682	0.02585	0.02524	0.02441	0.02368	0.02277	0.02194
0.02118	0.02032	0.01923	0.01837	0.01788	0.01712	0.01636	0.01544	0.01474	0.01431
0.01370	0.01297	0.01263	0.01221	0.01181	0.01135	0.01080	0.00974	0.00919	0.00836
0.00790	0.00748	0.00681	0.00647	0.00613	0.00558	0.00534	0.00494	0.00436	0.00403
0.00351									

Annex B (informative): Example Definition of Mode Command/Request decision thresholds

Following table 3 gives an example definition of Mode Command/Request decision thresholds for the TCH/AFS traffic channel employing a codec mode set which contains the 12.2 kbit/s, the 7.95 kbit/s, and the 5.9 kbit/s codec modes. Table 4 gives an example definition of Mode Command/Request decision thresholds for the TCH/AHS traffic channel employing a codec mode set which contains the 7.95 kbit/s, the 6.7 kbit/s, the 5.9 kbit/s, and the 5.15 kbit/s codec modes.

Table 3: MC/MR decision thresholds for TCH/AFS

MC'/MR'	THR_MC_Dn(MC')/ THR_MR_Dn(MR')	THR_MC_Up(MC')/ THR_MR_Up(MR')
12.2 kbit/s	11.5 dB	+ ∞
7.95 kbit/s	6.5 dB	13.5 dB
5.9 kbit/s	- ∞	8.5 dB

Table 4: MC/MR decision thresholds for TCH/AHS

MC'/MR'	THR_MC_Dn(MC')/ THR_MR_Dn(MR')	THR_MC_Up(MC')/ THR_MR_Up(MR')
7.95 kbit/s	15.0 dB	+ ∞
6.7 kbit/s	12.5 dB	17.0 dB
5.9 kbit/s	11.0 dB	15.0 dB
5.15 kbit/s	- ∞	13.0 dB

Annex C (informative): Principles for AMR codec mode adaptation with TFO

This annex C describes the procedures that are used for the codec mode adaptation of an Adaptive Multi-Rate (AMR) call over two radio links when Tandem Free Operation (TFO) is active between them. The mechanism to initiate TFO between AMR calls is described in GSM 08.62. It is considered as a prerequisite that a common Active Codec Set has been defined between the BSSs (by the TFO_Protocol) and that TFO is ongoing with the same Active Codec Set on each side.

The codec mode used in one direction may be different from the one used in the other direction, but for one direction the same codec mode is used from one MS to the other MS. The codec mode adaptation is performed independently on each direction, but in one direction the codec mode adaptation is triggered by both radio interfaces.

The principle for codec mode adaptation in ongoing TFO is always that the BTS controlling the MS takes the final decision to upgrade or downgrade its local uplink direction. This BTS sends the Codec Mode Command downlink.

The Codec Mode Request for the local uplink direction is taken directly into account and the effective delay is not higher than in normal connections.

The Codec Mode Request from the remote side in the remote downlink direction is also taken into account, but it becomes active with a reaction time increased by the round trip delay between both BTSs.

Upgrading is possible only if both radio links in one direction (first uplink then downlink) are good enough.

Downgrading is necessary already if one (or both) radio link is not good enough.

C.1 Downgrading

For an active AMR call without TFO, the codec mode is downgraded when the quality of the radio link decreases. In that case the codec bit rate is reduced so that more throughput is left on the radio interface to add protection. The principle when TFO is active is that as soon as one side detects the need to downgrade the codec rate, it informs the other side and the codec mode is immediately downgraded. There is no negotiation before downgrading.

C.1.1 Uplink downgrading

Figure C.1.1 shows the uplink adaptation due to detection by the BTS1 of a bad quality in the uplink from the MS1. In that case the round trip delay between BTS1 and BTS2 has no impact, as the uplink codec adaptation is decided immediately by BTS1 and performed by the MS1.

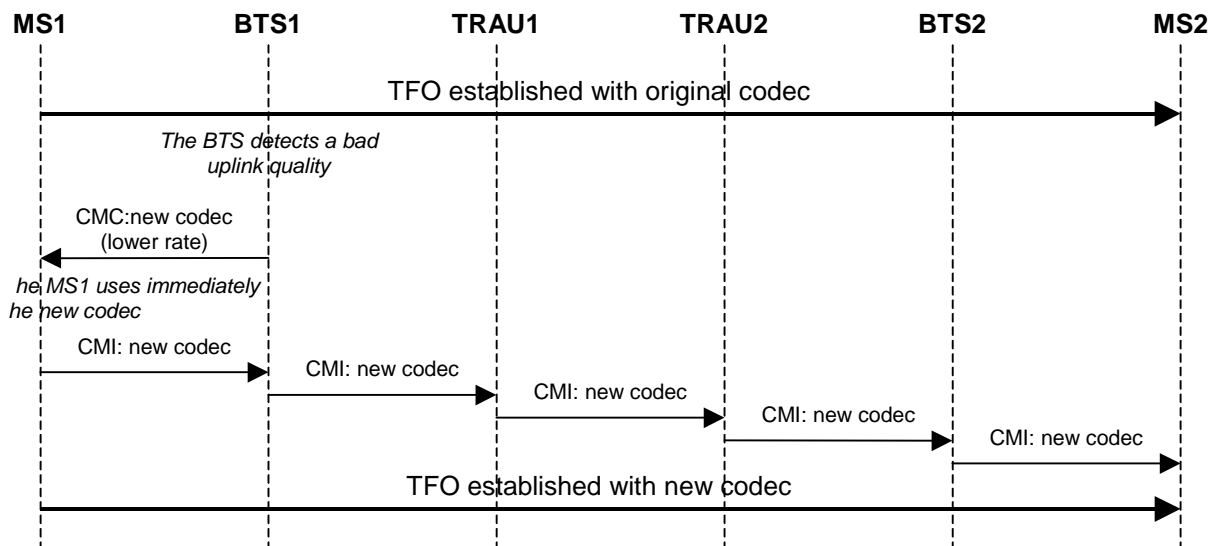

Figure C.1.1: Uplink Downgrading

C.1.2 Downlink downgrading

Figure C.1.2 shows the downlink adaptation due to detection by the MS1 of a bad quality of the downlink from the BTS1. The codec mode adaptation must be performed on the far end MS (MS2), where the source encoder is located. In that case the round trip delay before the downlink adaptation is effective has an high impact. If TFO would not be active, the round trip delay would be smaller, because the Codec Mode Request sent by the BTS1 to the TRAU1 would be immediately taken into account by the TRAU1 and the new codec mode applied in downlink: without TFO ongoing the (tandem) source encoder is located in TRAU1.

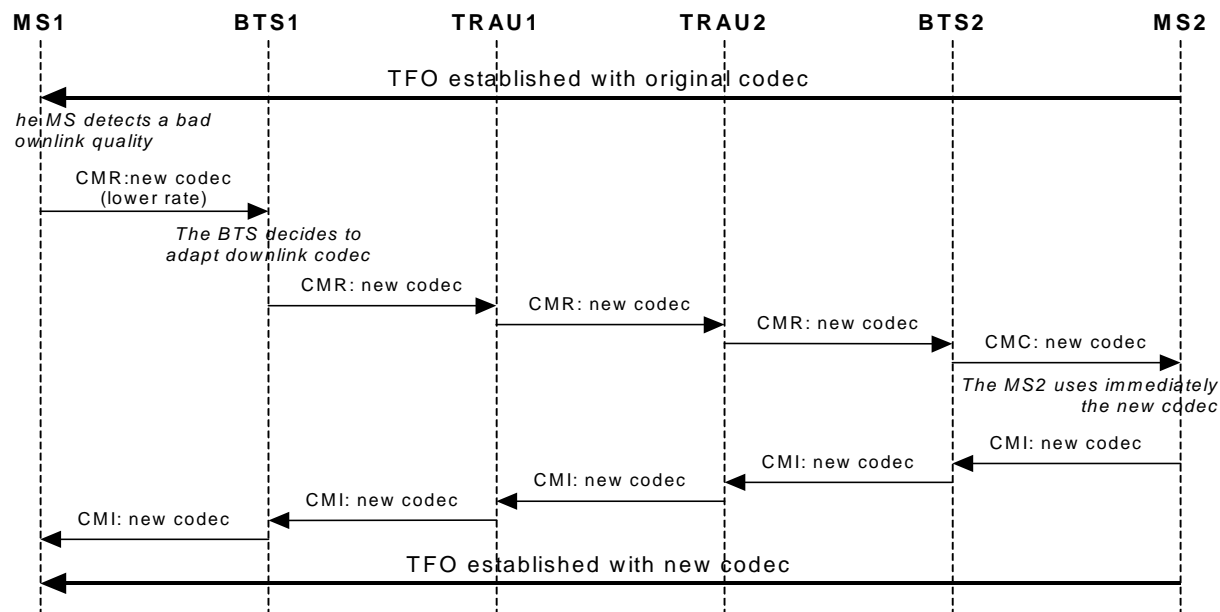

Figure C.1.2: Downlink Downgrading

C.2 Upgrading

When the radio quality becomes better in one direction on both BSSs, then the signal on the radio interfaces needs less protection and consequently the useful speech information can be increased: the codec can be changed to a codec with a higher bit rate. The principle when TFO is active is that the decision to upgrade the codec is taken by the side that monitors the uplink quality. If a good quality has been detected in the uplink direction by this BTS2, then this BTS2 upgrades the Codec Mode, if the Code Mode Request from the peer MS1 allows that (when the downlink of the other side is also good).

C.2.1 Downlink upgrading

In figure C.2.1 the downlink is monitored by MS1 and the uplink by BTS2.

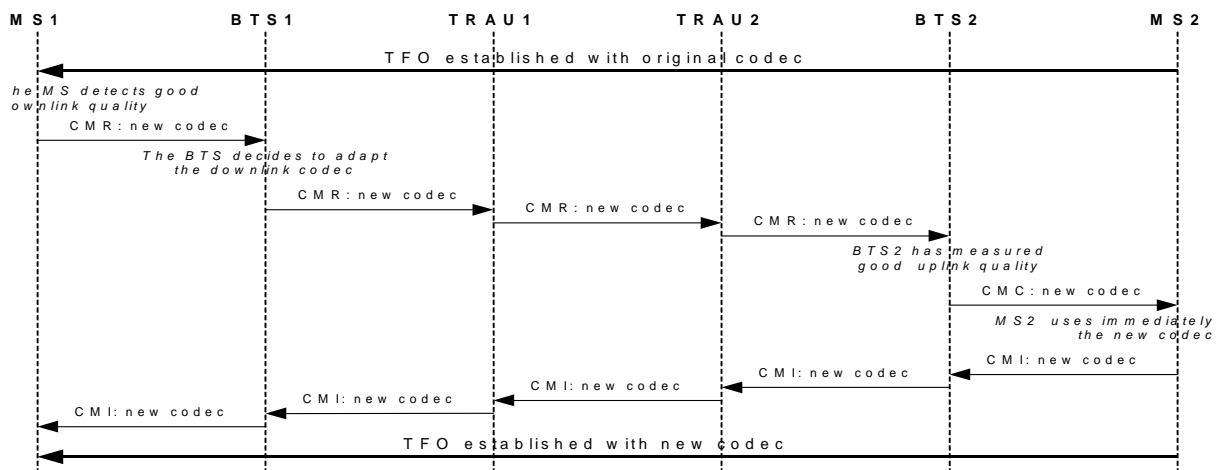

Figure C.2.1: Downlink Upgrading

In that case the round trip delay from BTS1 to BTS2 before the codec adaptation is effective in downlink to MS1 has an high impact. The delay from the BTS2 to the MS2 before the codec adaptation is effective in uplink is small. The "effective" round trip delay may even be "indefinite" if either MS1 or BTS2 is not able to upgrade its codec mode.

In the figure above, if BTS2 had not measured a good uplink radio quality, then no adaptation would have been performed. The MS1 respectively BTS1 would go on sending continuously Code Mode Request for the higher codec mode.

C.2.2 Uplink upgrading

In figure C.2.2 the downlink is monitored by BTS 2.

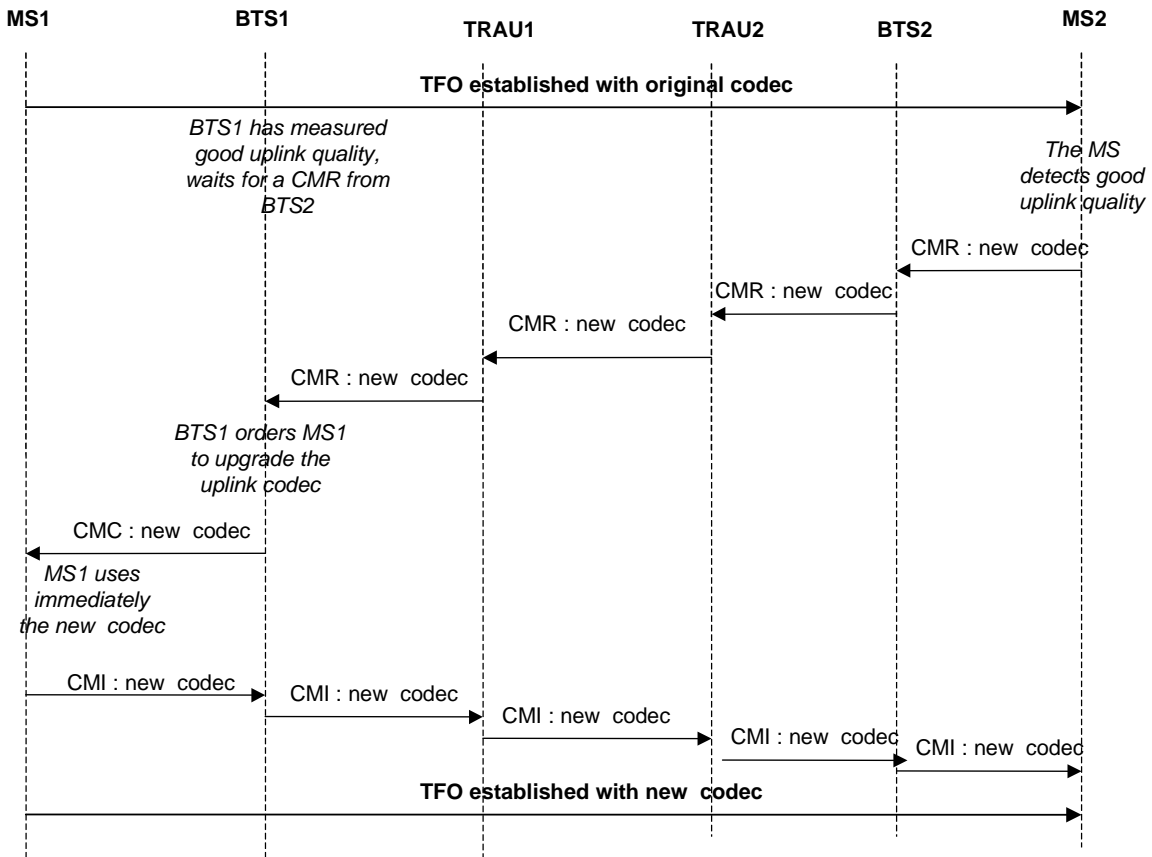

Figure C.2.2: Uplink Upgrading

The round trip delay before the codec adaptation is effective has a low impact, if the peer MS is able to upgrade its downlink codec mode. The round trip delay may even be indefinite if the peer MS is not able to upgrade its downlink codec mode.

In the figure above, if MS2 had not measured a good downlink radio quality, then no adaptation would have been performed.

Annex D (informative): Change control history

SPEC	SMG#	CR	PHS	VERS	NEW_V	SUBJECT
05.09	s30	A001	R98	70.1	7.1.0	Transmission Phase of AMR Inband Information
05.09	s30	A004	R98	7.0.1	7.1.0	Introduction of RATSCCH for AMR
05.09	s31	A005	R98	7.1.0	7.2.0	Clarification of the identification of the codec modes within the active codec set
05.09	s31			7.2.0	8.0.0	Version 8.0.0 for Release 1999
05.09				8.0.0	8.0.1	Update to Version 8.0.1 for Publication

History

Document history		
V8.0.0	May 2000	One-step Approval Procedure OAP 20000901: 2000-05-03 to 2000-09-01
V8.0.1	October 2000	Publication