

Draft **ETSI EN 301 708** V7.1.0 (1999-07)

---

*European Standard (Telecommunications series)*

**Digital cellular telecommunications system (Phase 2+);  
Voice Activity Detector (VAD) for Adaptive Multi-Rate (AMR)  
speech traffic channels;  
General description  
(GSM 06.94 version 7.1.0 Release 1998)**

---



**GSM**®  
GLOBAL SYSTEM FOR  
MOBILE COMMUNICATIONS

**ETSI** 

---

Reference

---

DEN/SMG-110694Q7 (ftc03ic0.PDF)

Keywords

---

Digital cellular telecommunications system,  
Global System for Mobile communications (GSM)

**ETSI**

Postal address

---

F-06921 Sophia Antipolis Cedex - FRANCE

Office address

---

650 Route des Lucioles - Sophia Antipolis  
Valbonne - FRANCE  
Tel.: +33 4 92 94 42 00 Fax: +33 4 93 65 47 16  
Siret N° 348 623 562 00017 - NAF 742 C  
Association à but non lucratif enregistrée à la  
Sous-Préfecture de Grasse (06) N° 7803/88

Internet

---

[secretariat@etsi.fr](mailto:secretariat@etsi.fr)  
Individual copies of this ETSI deliverable  
can be downloaded from  
<http://www.etsi.org>  
If you find errors in the present document, send your  
comment to: [editor@etsi.fr](mailto:editor@etsi.fr)

---

**Copyright Notification**

---

No part may be reproduced except as authorized by written permission.  
The copyright and the foregoing restriction extend to reproduction in all media.

© European Telecommunications Standards Institute 1999.  
All rights reserved.

# Contents

Intellectual Property Rights.....	4
Foreword .....	4
1 Scope.....	5
2 References.....	5
3 Technical Description of VAD Option 1 .....	5
3.1 Definitions, symbols and abbreviations .....	5
3.1.1 Definitions.....	5
3.1.2 Symbols.....	5
3.1.2.1 Variables.....	6
3.1.2.2 Constants .....	6
3.1.2.3 Functions .....	8
3.1.3 Abbreviations .....	8
3.2 General.....	8
3.3 Functional description.....	8
3.3.1 Filter bank and computation of sub-band levels.....	9
3.3.2 Pitch detection.....	11
3.3.3 Tone detection.....	12
3.3.4 Correlated Complex Signal Analysis (and detection).....	12
3.3.5 VAD decision.....	13
3.3.5.1 Hangover addition .....	14
3.3.5.2 Background noise estimation.....	15
4 Technical Description of VAD Option 2.....	18
4.1 Definitions, symbols and abbreviations .....	18
4.1.1 Definitions.....	18
4.1.2 Symbols.....	18
4.1.2.1 Variables.....	18
4.1.2.2 Constants .....	19
4.1.2.3 Functions .....	20
4.1.3 Abbreviations .....	21
4.2 General.....	21
4.3 Functional description.....	21
4.3.1 Frequency Domain Conversion .....	22
4.3.2 Channel Energy Estimator.....	22
4.3.3 Channel SNR Estimator .....	23
4.3.4 Voice Metric Calculation .....	23
4.3.5 Frame SNR and Long-Term Peak SNR Calculation .....	23
4.3.6 Negative SNR Sensitivity Bias.....	24
4.3.7 VAD Decision .....	24
4.3.8 Spectral Deviation Estimator.....	25
4.3.9 Sinewave Detection.....	26
4.3.10 Background Noise Update Decision .....	27
4.3.10 Background Noise Estimate Update.....	27
5 Computational details .....	28
<b>Annex A (informative): Document change history.....</b>	<b>29</b>
History .....	30

---

## Intellectual Property Rights

IPRs essential or potentially essential to the present document may have been declared to ETSI. The information pertaining to these essential IPRs, if any, is publicly available for **ETSI members and non-members**, and can be found in SR 000 314: "*Intellectual Property Rights (IPRs); Essential, or potentially Essential, IPRs notified to ETSI in respect of ETSI standards*", which is available **free of charge** from the ETSI Secretariat. Latest updates are available on the ETSI Web server (<http://www.etsi.org/ipr>).

Pursuant to the ETSI IPR Policy, no investigation, including IPR searches, has been carried out by ETSI. No guarantee can be given as to the existence of other IPRs not referenced in SR 000 314 (or the updates on the ETSI Web server) which are, or may be, or may become, essential to the present document.

---

## Foreword

This European Standard (Telecommunications series) has been produced by ETSI Technical Committee Special Mobile Group (SMG), and is now submitted to the ETSI standards One-step Approval Procedure.

The present document specifies two options (Option 1 and Option 2) for the Voice Activity Detector (VAD) to be used in the Discontinuous Transmission (DTX) for Adaptive Multi Rate (AMR) speech traffic channels within the digital cellular telecommunications system. Implementors of mobile station and infrastructure equipment conforming to the AMR specifications can choose which of the two VAD options to implement. There are no interoperability factors associated with this choice.

The contents of the present document is subject to continuing work within SMG and may change following formal SMG approval. Should SMG modify the contents of the present document it will be re-released with an identifying change of release date and an increase in version number as follows:

Version 7.x.y

where:

- 7 indicates Release 1998 of GSM Phase 2+
- x the second digit is incremented for all changes of substance, i.e. technical enhancements, corrections, updates, etc.
- y the third digit is incremented when editorial only changes have been incorporated in the specification.

<b>Proposed national transposition dates</b>	
Date of latest announcement of this EN (doa):	3 months after ETSI publication
Date of latest publication of new National Standard or endorsement of this EN (dop/e):	6 months after doa
Date of withdrawal of any conflicting National Standard (dow):	6 months after doa

---

# 1 Scope

The present document specifies two alternatives for the Voice Activity Detector (VAD) to be used in the Discontinuous Transmission (DTX) as described in [3]. Implementors of mobile station and infrastructure equipment conforming to the AMR specifications can choose which of the two VAD options to implement. There are no interoperability factors associated with this choice.

The requirements are mandatory on any VAD to be used either in GSM Mobile Stations (MS)s or Base Station Systems (BSS)s that utilize the AMR speech traffic channel.

---

# 2 References

The following documents contain provisions which, through reference in this text, constitute provisions of the present document.

- References are either specific (identified by date of publication, edition number, version number, etc.) or non-specific.
- For a specific reference, subsequent revisions do not apply.
- For a non-specific reference, the latest version applies.
- A non-specific reference to an ETS shall also be taken to refer to later versions published as an EN with the same number.
- For this Release 1998 document, references to GSM documents are for Release 1998 versions (version 7.x.y).

- [1] GSM 06.73: "Digital cellular telecommunications system (Phase 2+); ANSI-C code for the Adaptive Multi Rate (AMR) speech codec".
- [2] GSM 06.90: "Digital cellular telecommunications system (Phase 2+); Adaptive Multi Rate (AMR) speech transcoding".
- [3] GSM 06.93: "Digital cellular telecommunications system (Phase 2+); Discontinuous transmission (DTX) for Adaptive Multi Rate (AMR) speech traffic channels".
- [4] ITU, The International Telecommunications Union, Blue Book, Vol. III, Telephone Transmission Quality, IXth Plenary Assembly, Melbourne, 14-25 November, 1988, Recommendation G.711, Pulse code modulation (PCM) of voice frequencies.

---

# 3 Technical Description of VAD Option 1

## 3.1 Definitions, symbols and abbreviations

### 3.1.1 Definitions

For the purposes of this ETS, the following definitions apply:

**frame:** Time interval of 20 ms corresponding to the time segmentation of the speech transcoder.

### 3.1.2 Symbols

For the purposes of this ETS, the following symbols apply.

### 3.1.2.1 Variables

<b>bckr_est[n]</b>	background noise estimate
<b>burst_count</b>	counts length of a speech burst, used by VAD hangover addition
<b>hang_count</b>	hangover counter, used by VAD hangover addition
<b>complex_hang_count</b>	hangover counter, used by CAD hangover addition
<b>complex_hang_timer</b>	hangover initiator, used fo Complex Activity Estimation
<b>lagcount</b>	pitch detection counter
<b>level[n]</b>	signal level
<b>new_speech</b>	pointer of the speech encoder, points a buffer containing last received samples of a speech frame [2]
<b>noise_level</b>	average level of the background noise estimate
<b>oldlagcount</b>	lagcount of the previous frame
<b>pitch</b>	flag indicating presence of a periodic signal
<b>complex_warning</b>	flag indicating the presence of a complex signal.
<b>best_corr_hp</b>	normalized and limited value from maximum HP filtered correlation vector
<b>corr_hp</b>	filtered best_corr_hp values
<b>pow_sum</b>	power of the input frame
<b>s(i)</b>	samples of the input framer
<b>snr_sum</b>	measure between input frame and noise estimate
<b>stat_count</b>	stationarity counter
<b>stat_rat</b>	measure indicating stationary
<b>T_op[n]</b>	open-loop lags [2]
<b>t0</b>	autocorrelation maxima calculated by the open-loop pitch analysis [2]
<b>t1</b>	signal power related to the autocorrelation maxima t0 [2]
<b>tone</b>	flag indicating the presence of a tone
<b>vad_thr</b>	VAD threshold
<b>VAD_flag</b>	boolean VAD flag
<b>vadreg</b>	intermediate VAD decision
<b>complex_low</b>	intermediate complex signal decisions
<b>complex_high</b>	intermediate complex signal decisions

### 3.1.2.2 Constants

<b>ALPHA_UP1</b>	constant for updating noise estimate (see subclause 5.4.2)
<b>ALPHA_DOWN1</b>	constant for updating noise estimate (see subclause 5.4.2)

<b>ALPHA_UP2</b>	constant for updating noise estimate (see subclause 5.4.2)
<b>ALPHA_DOWN2</b>	constant for updating noise estimate (see subclause 5.4.2)
<b>ALPHA3</b>	constant for updating noise estimate (see subclause 5.4.2)
<b>ALPHA4</b>	constant for updating average signal level (see subclause 5.4.2)
<b>ALPHA5</b>	constant for updating average signal level (see subclause 5.4.2)
<b>BURST_LEN_HIGH_NOISE</b>	constant for controlling VAD hangover addition (see subclause 5.4.1)
<b>BURST_LEN_LOW_NOISE</b>	constant for controlling VAD hangover addition (see subclause 5.4.1)
<b>COEFF3</b>	coefficient for the filter bank (see subclause 5.1)
<b>COEFF5_1</b>	coefficient for the filter bank (see subclause 5.1)
<b>COEFF5_2</b>	coefficient for the filter bank (see subclause 5.1)
<b>HANG_LEN_HIGH_NOISE</b>	constant for controlling VAD hangover addition (see subclause 5.4.1)
<b>HANG_LEN_LOW_NOISE</b>	constant for controlling VAD hangover addition (see subclause 5.4.1)
<b>HANG_NOISE_THR</b>	constant for controlling VAD hangover addition (see subclause 5.4.1)
<b>L_FRAME</b>	size of a speech frame, 160
<b>L_NEXT</b>	length for the lookahead of the speech encoder, 40
<b>LTHRESH</b>	threshold for pitch detection (see subclause 5.2)
<b>NOISE_MAX</b>	maximum value for noise estimate (see subclause 5.4.2)
<b>NOISE_MIN</b>	minimum value for noise estimate (see subclause 5.4.2)
<b>NTHRESH</b>	threshold for pitch detection (see subclause 5.2)
<b>POW_PITCH_THR</b>	threshold for pitch detection (see subclause 5.4)
<b>POW_COMPLEX_THR</b>	threshold for complex detection (see subclause 5.4)
<b>STAT_COUNT</b>	threshold for stationary detection (see subclause 5.4.2)
<b>CAD_MIN_STAT_COUNT</b>	minimum threshold after complex warning
<b>STAT_THR</b>	threshold for stationary detection (see subclause 5.4.2)
<b>STAT_THR_LEVEL</b>	threshold for stationary detection (see subclause 5.4.2)
<b>TONE_THR</b>	threshold for tone detection (see subclause 5.3)
<b>VAD_P1</b>	constant of computation for VAD threshold (see subclause 5.4.2)
<b>VAD_POW_LOW</b>	constant for controlling VAD hangover addition (see subclause 5.4.1)
<b>VAD_SLOPE</b>	constant of computation for VAD threshold (see subclause 5.4)
<b>VAD_THR_HIGH</b>	constant of computation for VAD threshold (see subclause 5.4)
<b>CVAD_THRESH_ADAPT_HIGH</b>	constant for updating complex_high
<b>CVAD_THRESH_ADAPT_LOW</b>	constant for updating complex_low
<b>CVAD_THRESH_HANG</b>	constant for updating complex_hang_timer
<b>CVAD_HANG_LIMIT</b>	constant for initiating complex_hang_count

**CVAD\_HANG\_LENGTH** constant for resetting complex\_hang\_count

### 3.1.2.3 Functions

+	addition
-	subtraction
*	multiplication
/	division
x	absolute value of x
<b>AND</b>	Boolean AND
<b>OR</b>	Boolean OR

$$\sum_{n=a}^b x(n) = x(a) + x(a+1) + \dots + x(b-1) + x(b)$$

$$\text{MIN}(x,y) = \begin{cases} x, & x \leq y \\ y, & y < x \end{cases}$$

$$\text{MAX}(x,y) = \begin{cases} x, & x \geq y \\ y, & y > x \end{cases}$$

### 3.1.3 Abbreviations

<b>ANSI</b>	American National Standards Institute
<b>DTX</b>	Discontinuous Transmission
<b>VAD</b>	Voice Activity Detector
<b>CAD</b>	Complex Activity Detection
<b>CNG</b>	Comfort Noise Generation

## 3.2 General

The function of the VAD algorithm is to indicate whether each 20 ms frame contains signals that should be transmitted, i.e. speech, music or information tones. The output of the VAD algorithm is a Boolean flag (VAD\_flag) indicating presence of such signals.

## 3.3 Functional description

The block diagram of the VAD algorithm is depicted in figure 1. The VAD algorithm uses parameters of the speech encoder to compute the Boolean VAD flag (VAD\_flag). Samples of the Input frame (s(i)) are divided into sub-bands and level of the signal in each band (level[n]) is calculated. Input for the pitch detection function are open-loop lags (T\_op[n]), which are calculated by open-loop pitch analysis of the speech encoder. The pitch detection function computes a flag (pitch) which indicates presence of pitch. Tone detection function calculates a flag (tone), which indicates presence of an information tone. Tones are detected based on pitch gain of the open-loop pitch analysis. The pitch gain is estimated using autocorrelation values (t0 and t1) received from the pitch analysis. Complex Signal Detection function calculates a flag (complex\_warning), which indicates presence of a correlated complex signal such as music. Correlated complex signals are detected based on analysis of the correlation vector available in the open-loop pitch analysis. The VAD decision function estimates background noise levels. Intermediate VAD decision is calculated based on the comparison of the background noise estimate and levels of the input frame (level[n]). Finally, the VAD flag is calculated by adding hangover to the intermediate VAD decision.



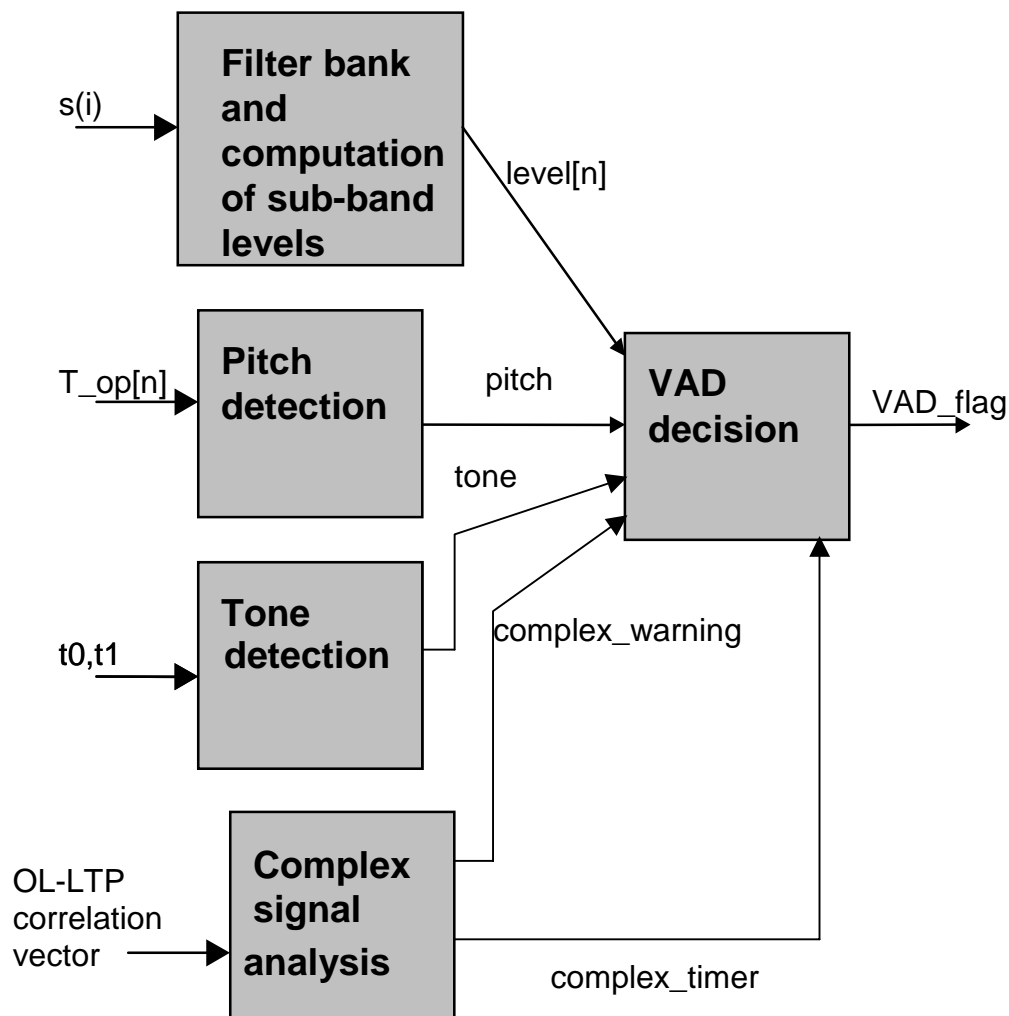

Figure 3.1: Simplified block diagram of the VAD algorithm: Option 1

### 3.3.1 Filter bank and computation of sub-band levels

The input signal is divided into frequency bands using 9-band filter bank (figure 2). Cut-off frequencies for the filter bank are shown in table 3.1.

**Table 3.1: Cut-off frequencies for the filter bank**

Band number	Frequencies
1	0 - 250 Hz
2	250 - 500 Hz
3	500 - 750 Hz
4	750 - 1000 Hz
5	1000 - 1500 Hz
6	1500 - 2000 Hz
7	2000 - 2500 Hz
8	2500 - 3000 Hz
9	3000 - 4000 Hz

Input for the filter bank is the speech frame pointed by the new\_speech pointer of the speech encoder [1]. Input values for the filter bank are scaled down by one bit. This ensures safe scaling, i.e. saturation can not occur during calculation of the filter bank.

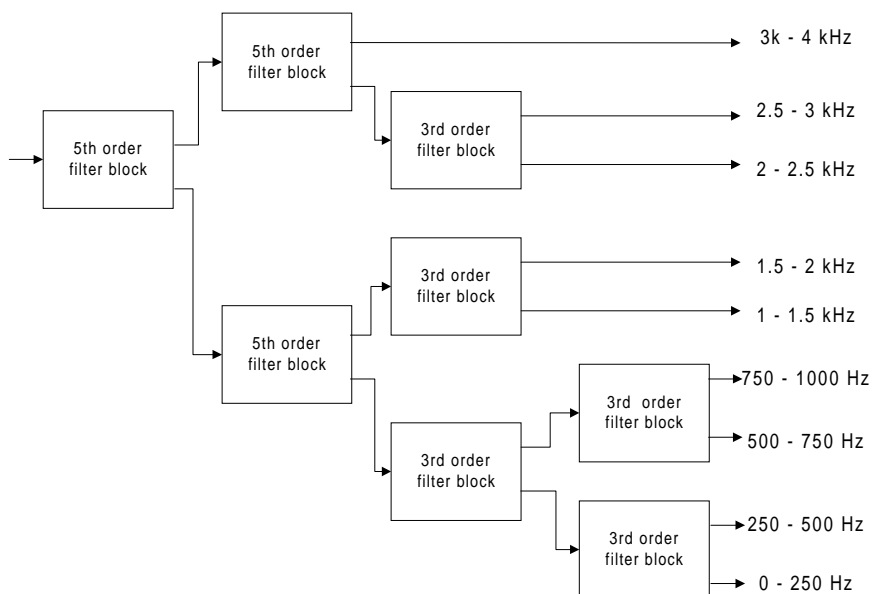

**Figure 3.2: Filter bank**

The filter bank consists of 5<sup>th</sup> and 3<sup>rd</sup> order filter blocks. Each filter block divides the input into high-pass and low-pass parts and decimates the sampling frequency by 2. The 5<sup>th</sup> order filter block is calculated as follows:

$$x_{lp}(i) = 0.5 * (A_1(x(i-1)) + A_2(x(i))) \tag{3.1a}$$

$$x_{hp}(i) = 0.5 * (A_1(x(i-1)) - A_2(x(i))) \tag{3.1b}$$

where

x(i) input signal for a filter block

$x_{lp}(i)$  low-pass component

$x_{hp}(i)$  high-pass component

The 3<sup>rd</sup> order filter block is calculated as follows:

$$x_{lp}(i) = 0.5 * (x(i) + A_3(x(i-1))) \quad (3.2a)$$

$$x_{hp}(i) = 0.5 * (x(i) - A_3(x(i-1))) \quad (3.2b)$$

The filters  $A_1()$ ,  $A_2()$ , and  $A_3()$  are first order direct form all-pass filters, whose transfer function is given by:

$$A(z) = \frac{C + z^{-1}}{1 + C * z^{-1}}, \quad (3.3)$$

where C is the filter coefficient.

Coefficients for the all-pass filters  $A_1()$ ,  $A_2()$ , and  $A_3()$  are COEFF5\_1, COEFF5\_2, and COEFF3, respectively.

Signal level is calculated at the output of the filter bank at each frequency band as follows:

$$level(n) = \sum_{i=START_n}^{END_n} |x_n(i)|, \quad (3.4)$$

where:

n index for the frequency band

$x_n(i)$  sample i at the output of the filter bank at frequency band n

$$START_n = \begin{cases} -2, & n \leq 4 \\ -4, & 5 \leq n \leq 8 \\ -8, & n = 9 \end{cases}$$

$$END_n = \begin{cases} 9, & n \leq 4 \\ 19, & 5 \leq n \leq 8 \\ 39, & n = 9 \end{cases}$$

Negative indices of  $x_n(i)$  refer to the previous frame.

### 3.3.2 Pitch detection

The purpose of the pitch detection function is to detect vowel sounds and other periodic signals. The pitch detection is based on comparison of open-loop lags ( $T_{op}[n]$ ), which are calculated by the speech encoder [2]. If the difference of consecutive open-loop lags ( $T_{op}[n]$ ) is smaller than a threshold, lagcount is incremented. If the sum of the lagcounts of two consecutive frames is high enough, the pitch flag is set. For 5.15 and 4.75 kbit/s rates, only one open-loop lag is calculated, and therefore only the first lag-comparison is made every frame. The pitch flag is calculated as follows:

Lagcount = 0;

If ( $|T\_op[-1] - T\_op[0]| < LTHRESH$ )

Lagcount = Lagcount + 1

If ( $|T\_op[0] - T\_op[1]| < LTHRESH$ )

Lagcount = Lagcount + 1

If (Lagcount + oldlagcount > NTHRESH)

pitch = 1

else

pitch = 0

oldlagcount = Lagcount

T\_op[-1] refers to the open-loop lag of the previous frame.

### 3.3.3 Tone detection

Tone detection is used to detect information tones, since the pitch detection function can not always detect these signals. Also, other signals which contain very strong periodic component are detected, because it may sound annoying if these signals are replaced by comfort noise. If the open-loop pitch gain is higher than the constant TONE\_THR, tone is detected and tone flag is set. The pitch gain can be tested by comparing variables t0 and t1 as follows:

if ( $t0 > TONE\_THR * t1$ )

tone = 1

The speech encoder calculates the pitch in three delay ranges, except for mode 10.2 kbit/s, where only one range is used. The above comparison is made once for each delay range and the tone flag should be set if the condition is true at least in one range. Otherwise, the tone flag should be set to zero.

The variables t0 and t1 are calculated by the open-loop pitch analysis of the speech encoder [2]. The variable t0 is autocorrelation maxima given by:

$$t0 = \sum_n s_w(n)s_w(n-k) \quad (3.5)$$

The variable t1 is the signal power related to the autocorrelation maxima t0 at the delay value k:

$$t1 = \sum_n s_w^2(n-k) \quad (3.6)$$

The open-loop pitch search and correspondingly the tone flag is computed twice in each frame, except for modes 5.15 kbit/s and 4.75 kbit/s, where it is computed only once.

### 3.3.4 Correlated Complex Signal Analysis (and detection)

Correlated complex signal detection is used to detect correlated signals in the highpass filtered weighted speech domain, since the pitch and tone detection functions can not always detect these signals. Signals which contain very strong correlation values in the high pass filtered domain are taken care of, because it may sound really annoying if these signals are replaced by comfort noise. If the statistics of the maximum normalized correlation value of a high pass filtered input signal indicates the presence of a correlated complex signal a flag **complex\_warning** is set. To reduce complexity the high band correlation analysis is performed in a simplified manner by analysing the high pass filtered fullband correlation vector which is available from the OL-LTP analysis performed by the speech encoder at least once in each frame.

$best\_corr\_hp_m$  is the maximum normalized value of the high pass filtered correlation in the range 19-146 limited to be in the range [1.0, 0.0]. (Note that the  $best\_corr\_hp$  value is delayed one frame). The high pass filter is a simple first order filter with coefficients [1, -1] The  $best\_corr\_hp$  value is filtered according to :

$$corr\_hp_{m+1} = (\alpha) * corr\_hp_m + (1 - \alpha) * best\_corr\_hp_m ,$$

where  $\alpha$  is varied between 0.98 and 0.8 as a function of  $corr\_hp_m$  and  $best\_corr\_hp_m$

The  $corr\_hp$  output value is thresholded into two to registers  $complex\_high$ ,  $complex\_low$  and one *counter*  $complex\_hang\_timer$ .

$complex\_low$  is set to 1 if the  $corr\_hp$  value is greater than CVAD\_THRESH\_ADAPT\_LOW.

$complex\_high$  is set to 1 if the  $corr\_hp$  value is greater than CVAD\_THRESH\_ADAPT\_HIGH.

$complex\_hang\_timer$  is increased by 1 if the  $corr\_hp$  value is greater than CVAD\_THRESH\_HANG. If the  $corr\_hp$  value is lower than or equal to CVAD\_THRESH\_HANG the  $complex\_hang\_timer$  value is set to 0.

The flag **complex\_warning** is set if  $complex\_low$  have been set for 15 consecutive frames or  $complex\_high$  has been set for 8 consecutive frames.

The open-loop pitch search and correspondingly the tone flag is computed twice in each frame, except for modes 5.15 kbit/s and 4.75 kbit/s, where it is computed only once. The computation of the  $corr\_hp$  value is however always done only once per frame using the newest correlation vector available.

### 3.3.5 VAD decision

Power of the input frame is calculated as follows:

$$pow\_sum = \sum_{i=L\_NEXT}^{L\_FRAME-L\_NEXT-1} s(i) * s(i) , \tag{3.7}$$

where samples  $s(i)$  of the input frame are pointed by the  $new\_speech$  pointer of the speech encoder. If the power of the input frame ( $pow\_sum$ ) is lower than the constant POW\_PITCH\_THR, last pitch flag is set to zero. If the power of the input frame ( $pow\_sum$ ) is lower than the constant POW\_COMPLEX\_THR, last  $complex\_low$  flag is set to zero.

The difference between the signal levels of the input frame and background noise estimate is calculated as follows:

$$snr\_sum = \sum_{n=1}^9 MAX(1.0, \frac{level[n]}{bckr\_est[n]})^2 , \tag{3.8}$$

where:

$level[n]$  signal level at band n

$bckr\_est[n]$  level of background noise estimate at band n

VAD decision is made by comparing the variable  $snr\_sum$  to a threshold. The threshold ( $vad\_thr$ ) is tuned to get desired sensitivity at each background noise level. The higher the noise level the lower is the threshold. Specially, a low threshold at high-level background noise is needed to detect speech reliably enough, although probability of detecting noise as speech also increases.

Average level of background noise is calculated by adding noise estimates at each band:

$$noise\_level = \sum_{n=1}^9 bckr\_est[n] \tag{3.9}$$

Threshold is calculated using average noise level as follows:

$$vad\_thr = VAD\_SLOPE * (noise\_level - VAD\_PI) + VAD\_THR\_HIGH, \quad (3.10)$$

where VAD\_SLOPE, VAD\_PI, and VAD\_THR\_HIGH are constants.

The variable vadreg indicates intermediate VAD decision and it is calculated as follows:

```
if (snr_sum > vad_thr)
```

```
    vadreg = 1
```

```
else
```

```
    vadreg = 0
```

### 3.3.5.1 Hangover addition

Before the final VAD flag is given, a hangover is added. The hangover addition helps to detect low power endings of speech bursts, which are subjectively important but difficult to detect. Also a long hangover is added if the signal has been found to be of very complex nature for a long time (2 seconds) since the VAD is not likely to work reliably for such a complex signal.

VAD flag is set to “1” if less than hang\_len frames with “0” decision have been elapsed since burst\_len consecutive “1” decisions have been detected. The variables hang\_len and burst\_len are set depending on the average noise level (noise\_level). The *vad\_flag* is also controlled by the *complex\_hang\_count* which indicates that the signal is too complex for the VAD and should not be used with a Comfort noise generation algorithm. The filtered correlation value *corr\_hp* is also used as an activity indication after the VAD has indicated noise for a while (during 200 ms), this will aid in situations where the VAD noise estimate has adapted to a rather stationary but still all to complex signal to make it sound well with CNG.

The power of the input frame is compared to a threshold (VAD\_POW\_LOW). If the power is lower, the VAD flag is set to “0” and no hangover is added. The VAD\_flag is calculated as follows:

```
if (noise_level > HANG_NOISE_THR)
```

```
    burst_len = BURST_LEN_HIGH_NOISE
```

```
    hang_len = HANG_LEN_HIGH_NOISE
```

```
else
```

```
    burst_len = BURST_LEN_LOW_NOISE
```

```
    hang_len = HANG_LEN_LOW_NOISE
```

```
if (complex_hang_timer > CVAD_HANG_LIMIT) {
```

```
    if (complex_hang_count < CVAD_HANG_LENGTH {
```

```
        complex_hang_count = CVAD_HANG_LENGTH;
```

```
    }
```

```
}
```

```
if (powsum < VAD_POW_LOW){
```

```
    burst_count = 0
```

```
    hang_count = 0
```

```
    complex_hang_count = 0;
```

```
    complex_hang_timer = 0;
```

```
    Vad_flag=0;
```

```

    Goto Exit;
}
VAD_flag=0;
if(complex_hang_count != 0){
    burst_count = BURST_LEN_HIGH_NOISE;
    complex_hang_count = complex_hang_count - 1 ;
    VAD_flag=1;
    goto Exit
} else {
    if ( (the 10 last out of 11 vadreg values all are zero) AND
        (corr_hp > CVAD_THRESH_IN_NOISE) ) {
        VAD_flag = 1;
        Goto Exit
    }
}

```

```

if (vadreg = 1){
    burst_count = burst_count + 1 }
    if (burst_count >= burst_len){
        hang_count = hang_len
    }
    VAD_flag = 1
} else {
    burst_count = 0
    if (hang_count > 0){
        hang_count = hang_count - 1
        VAD_flag=1
    }
}

```

Label **Exit**

### 3.3.5.2 Background noise estimation

Background noise estimate (bckr\_est[n]) is updated using amplitude levels of the previous frame. Thus, the update is delayed by one frame to avoid undetected start of speech bursts to corrupt the noise estimate. If the internal VAD

decision is "1" or if pitch has been detected, the noise estimate is not updated upwards. The update speed for the current frame is selected as follows:

if ((vadreg for the last 4 frames has been zero) AND

(pitch for the last 4 frames has been zero) AND

(we are not in complex signal hangover))

alpha\_up = ALPHA\_UP1

alpha\_down = ALPHA\_DOWN1

else

if ((stat\_count = 0) AND

(not in complex\_signal hangover))

alpha\_up = ALPHA\_UP2

alpha\_down = ALPHA\_DOWN2

else

alpha\_up = 0

alpha\_down = ALPHA3

The variable stat\_count indicates stationary and its propose is explained later in this subclause. The variables alpha\_up and alpha\_down define the update speed to upwards and downwards. The update speed for each band n is selected as follows:

if ( $bckr\_est_m[n] < level_{m-1}[n]$ )

alpha = alpha\_up

else

alpha = alpha\_down

Finally, noise estimate is updated as follows:

$$bckr\_est_{m+1}[n] = (1.0 - alpha) * bckr\_est_m[n] + alpha * level_{m-1}[n], \quad (3.11)$$

where:

n index of the frequency band

m index of the frame

Level of the background estimate (bckr\_est[n]) is limited between constants NOISE\_MIN and NOISE\_MAX.

If level of background noise increases suddenly, vadreg will be set to "1" and background noise is not updated upwards. To recover from this situation, update of the background noise estimate is enabled if the intermediate VAD decision (vadreg) is "1" for enough long time and spectrum is stationary. Stationary (stat\_rat) is estimated using following equation:

$$stat\_rat = \sum_{n=1}^9 \frac{MAX(STAT\_THR\_LEVEL, MAX(ave\_level_m[n], level_m[n]))}{MAX(STAT\_THR\_LEVEL, MIN(ave\_level_m[n], level_m[n]))} \quad (3.12)$$

If the stationary estimate (stat\_rat) is higher than a threshold, the stationary counter (stat\_count) is set to the initial value defined by constant STAT\_COUNT. The stationary counter (stat\_count) is also initialised if pitch or tone or a complex\_warning is detected. If the signal is not stationary but speech has been detected (VAD decision is "1"), stat\_count is decreased by one in each frame until it is zero.



```

if (complex_warning){
  If(stat_count < CAD_MIN_STAT_COUNT)
    stat_count = < CAD_MIN_STAT_COUNT
}

```

if ( ( 8 last vadreg flags have been zero) OR ( 2 last pitch flags have been one) OR ( 5 last tone flags have been one) )

```

  stat_count = STAT_COUNT

```

else

```

  if (stat_rat > STAT_THR)

```

```

    stat_count = STAT_COUNT

```

else

```

  if ((vadreg) AND (stat_count ≠ 0))

```

```

    stat_count = stat_count - 1

```

The average signal levels (*ave\_level*[*n*]) are calculated as follows:

$$ave\_level_{m+1}[n] = (1.0 - \alpha) * ave\_level_m[n] + \alpha * level_m[n] \quad (3.13)$$

The update speed (*alpha*) for the previous equation is selected as follows:

```

if (stat_count = STAT_COUNT)

```

```

  alpha = 1.0

```

else if (vadreg = 1)

```

  alpha=ALPHA5

```

else

```

  alpha = ALPHA4

```

---

## 4 Technical Description of VAD Option 2

### 4.1 Definitions, symbols and abbreviations

#### 4.1.1 Definitions

For the purposes of the present document, the following definitions apply:

**codec:** The combination of an encoder and decoder in series (encoder/decoder).

**compand:** The process of compressing and expanding a signal. In this text, the process is described in terms of PCM [4].

**Decoder:** Generally, a device for the translation of a signal from a digital representation into an analog format. For this standard, a device which converts speech encoded in the format specified in this standard to analog or an equivalent PCM representation.

**DFT:** See Discrete Fourier Transform.

**Discrete Fourier Transform (DFT):** A method of transforming a time domain sequence into a corresponding frequency domain sequence.

**Encoder:** Generally, a device for the translation of a signal into a digital representation. For this standard, a device which converts speech from an analog or its equivalent PCM representation to the digital representation described in this standard.

**Fast Fourier Transform (FFT):** An efficient implementation of the Discrete Fourier Transform.

**FFT:** See Fast Fourier Transform.

**Vocoder:** Voice coder.

**frame:** Time interval of 20 ms corresponding to the time segmentation of the speech transcoder.

#### 4.1.2 Symbols

For the purposes of this ETS, the following symbols apply.

##### 4.1.2.1 Variables

$\alpha_{ch}(m)$	channel energy smoothing factor
$\alpha(m)$	exponential windowing factor
$\Delta_E(m)$	estimated spectral deviation between current power spectrum and average long term power spectral estimate
$\phi(m)$	spectral peak-to-average ratio
$\sigma_q^{(i)}$	quantized channel SNR indices
$b(m)$	burst count
$b_{th}$	burst count threshold
$\{d(m)\}$	overlapped portion of the frame buffer of input samples

$E_{ch}(m,i)$	channel energy estimate; channel $i$ , subframe $m$
$\mathbf{E}_{ch}(m)$	vector of channel energy estimates, $0 \leq i < N_c$
$E_{dB}(m,i)$	estimated log power spectrum
$\mathbf{E}_{dB}(m)$	vector of log power spectrum estimates, $0 \leq i < N_c$
$\bar{E}_{dB}(m,n)$	average long term power spectral estimate
$\bar{\mathbf{E}}_{dB}(m)$	vector of average long term power spectral estimates, $0 \leq i < N_c$
$E_n(m,i)$	channel noise estimate
$\mathbf{E}_n(m)$	vector of channel noise estimates, $0 \leq i < N_c$
$E_{tn}(m)$	total estimated noise energy
$E_{tot}(m)$	total channel energy
$E'_{tot}(m)$	modified total channel energy
$h(m)$	hysteresis counter
$h_{cnt}$	hangover count
$h_o(n)$	overlap-and-add buffer of samples
$hyster\_cnt$	hysteresis counter to avoid long term creeping of $update\_cnt$
$last\_update\_cnt$	previous value of $update\_cnt$
$s_{hp}(n)$	sample at the output of the speech encoder high pass filter
$sinewave\_flag$	boolean flag, set TRUE when spectral peak-to-average ratio is greater than 10dB and the spectral deviation is less than DEV_THLD
$SNR$	Signal to Noise ratio
$SNR_p(m)$	long-term peak SNR
$SNR_q(m)$	quantized version of $SNR_p(m)$
$update\_cnt$	counter gating noise estimate update process
$update\_flag$	flag controlling noise estimate updating
$VAD(m)$	boolean VAD flag for subframe $m$
$VAD\_flag$	boolean VAD Flag
$v(m)$	sum of voice metrics
$v_{th}$	voice metric threshold

#### 4.1.2.2 Constants

$\alpha_H$	upper limit for values of $\alpha(m)$
$\alpha_L$	lower limit for values of $\alpha(m)$
$\alpha_n$	channel noise smoothing factor
$\zeta_p$	pre-emphasis factor
$b_{table}$	table to generate $b_{th}$

D	overlap (delay) in sample intervals
DEV_THLD	threshold for setting <i>sinewave_flag</i>
$E_{\text{floor}}$	low threshold for $E_{\text{tot}}(m)$
$E_H$	high energy endpoint for linear interpolation of $E_{\text{tot}}(m)$
$E_{\text{init}}$	minimum allowable channel noise initialisation energy
$E_L$	low energy endpoint for linear interpolation of $E_{\text{tot}}(m)$
$E_{\text{min}}$	minimum allowable channel energy
$f_H$	high channel combining table
$f_L$	low channel combining table
$g(n)$	trapezoidal window, $n = 0$ to $M$
$G(k)$	frequency domain transformation of $g(n)$
$h_{\text{table}}$	table to generate $h_{\text{cnt}}$
HYSTER_CNT_THLD	threshold for <i>hyster_cnt</i>
L	subframe length in samples
M	DFT sequence length
$N_c$	number of combined channels
NOISE_FLOOR_D	low threshold for $E_{\text{tot}}(m)$ in dB
UPDATE_CNT_THLD	threshold for <i>update_cnt</i>
UPDATE_THLD	threshold for $v(m)$
V	voice metric table
$v_{\text{table}}$	table to generate $v_{\text{th}}$

#### 4.1.2.3 Functions

+	addition
-	subtraction
*	multiplication
/	division
$\lfloor x \rfloor$	largest integer $\leq x$
<b>AND</b>	Boolean AND
<b>OR</b>	Boolean OR
$\sum_{n=a}^b x(n)$	$= x(a) + x(a+1) + \dots + x(b-1) + x(b)$

### 4.1.3 Abbreviations

<b>ANSI</b>	American National Standards Institute
<b>DTX</b>	Discontinuous Transmission
<b>VAD</b>	Voice Activity Detector
<b>CAD</b>	Complex Activity Detection
<b>CNG</b>	Comfort Noise Generation

## 4.2 General

The function of the VAD algorithm is to indicate whether each 20 ms frame contains signals that should be transmitted, i.e. speech, music or information tones. The output of the VAD algorithm is a Boolean flag (VAD\_flag) indicating presence of such signals.

## 4.3 Functional description

The block diagram of the VAD algorithm is depicted in figure 1. The VAD algorithm uses parameters of the speech encoder to compute the Boolean VAD flag (VAD\_flag).

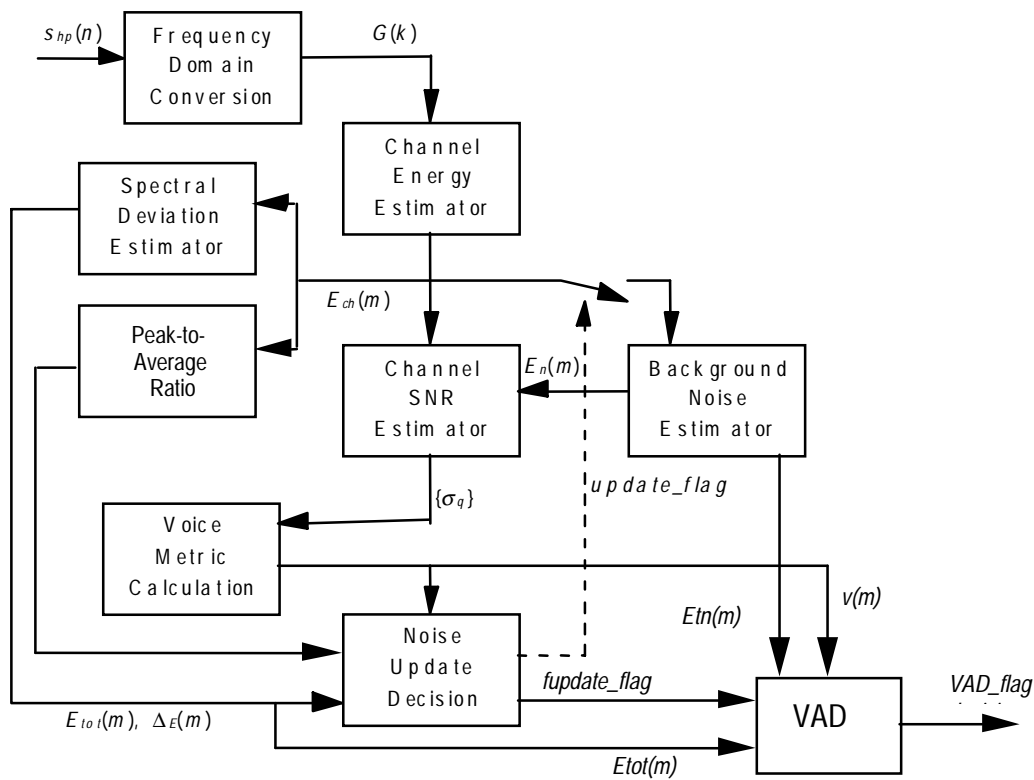

Figure 4.1: Block Diagram of the VAD algorithm: Option 2

**Input:**

- The output of the High-Pass Filter,  $\{s_{hp}(n)\}$
- $LTP\_flag$  is generated by the comparison of the long-term prediction gain to a constant threshold  $LTP\_THLD$ , where the long-term prediction gain  $\beta$  is derived from the speech encoder[2] open-loop pitch predictor.

**Output:**

- \_ The output of the vad is designated as VAD\_flag

**Initialization:**

The following variables shall be set to zero at initialization (frame  $m = 0$ ):

- \_ The pre-emphasis memory

The following shall be initialized to a startup value other than zero:

- \_ The channel energy estimate,  $\mathbf{E}_{ch}(m)$ , (see Section 4.3.2)
- \_ The long-term power spectral estimate,  $\bar{\mathbf{E}}_{dB}(m)$ , (see Section 4.3.5)
- \_ The channel noise estimate,  $\mathbf{E}_n(m)$ , (see Section 4.3.8)

**Processing:** The following procedures shall be executed two times per 20 ms speech frame and the current 10 ms subframe shall be denoted  $m$ .

### 4.3.1 Frequency Domain Conversion

The input signal is pre-emphasised and windowed prior to frequency domain conversion. This process is defined as

$$d(n) = s_{hp}(n) + \zeta_p s_{hp}(n-1), \quad 0 \leq n < L, \tag{4.1}$$

where  $d(n)$  is the pre-emphasised speech buffer,  $\zeta_p$  is the pre-emphasis factor, and  $L$  is the subframe length. A rectangular window is then used to frame the speech prior to frequency domain conversion, which is expressed as:

$$g(n) = \begin{cases} 0, & 0 \leq n < D, L + D \leq n < M \\ d(n - D), & D \leq n < L + D \end{cases}, \tag{4.2}$$

where  $D$  is the zero-padding offset into the DFT buffer, and  $M$  is the DFT length. The transformation of  $g(n)$  to the frequency domain is performed using the Discrete Fourier Transform (DFT) defined as:

$$G(k) = \frac{2}{M} \sum_{n=0}^{M-1} g(n) e^{-j2\pi nk/M}, \quad 0 \leq k < M \tag{4.3}$$

where  $e^{j\omega}$  is a unit amplitude complex phasor with instantaneous radial position  $\omega$ .

### 4.3.2 Channel Energy Estimator

Calculate the channel energy estimate  $\mathbf{E}_{ch}(m)$  for the current subframe,  $m$ , as:

$$E_{ch}(m, i) = \max \left\{ E_{\min}, \alpha_{ch}(m) E_{ch}(m-1, i) + (1 - \alpha_{ch}(m)) \frac{1}{f_H(i) - f_L(i) + 1} \sum_{k=f_L(i)}^{f_H(i)} |G(k)|^2 \right\}, \quad 0 \leq i < N_c \tag{4.4}$$

where  $E_{\min}$  is the minimum allowable channel energy,  $\alpha_{ch}(m)$  is the channel energy smoothing factor (defined below),  $N_c$  is the number of combined channels, and  $f_L(i)$  and  $f_H(i)$  are the  $i$ -th elements of the respective low and high channel combining tables.

The channel energy smoothing factor,  $\alpha_{ch}(m)$ , is defined as:

$$\alpha_{ch}(m) = \begin{cases} 0, & m \leq 1 \\ 0.45, & m > 1 \end{cases} \quad (4.5)$$

So, this means that  $\alpha_{ch}(m)$  assumes a value of zero for the first frame ( $m = 1$ ) and a value of 0.45 for all subsequent frames. This allows the channel energy estimate to be initialized to the unfiltered channel energy of the first frame.

### 4.3.3 Channel SNR Estimator

Estimate the channel SNR vector  $\{ \sigma \}$  as:

$$\sigma(i) = 10 \log_{10} \left( \frac{E_{ch}(m, i)}{E_n(m, i)} \right), \quad 0 \leq i < N_c \quad (4.6)$$

where  $E_n(m)$  is the current channel noise energy estimate (see Section 4.3.8), and then quantify the channel SNR estimate in 3/8 dB steps to yield the channel SNR indices  $\{ \sigma_q \}$  given as:

$$\sigma_q(i) = \max\{0, \min\{89, \text{round}\{\sigma(i)/0.375\}\}\}, \quad 0 \leq i < N_c \quad (4.7)$$

where the values of  $\{ \sigma_q \}$  are constrained to be between 0 and 89, inclusive.

### 4.3.4 Voice Metric Calculation

Next, calculate the sum of voice metrics as:

$$v(m) = \sum_{i=0}^{N_c-1} V(\sigma_q(i)), \quad (4.8)$$

where  $V(k)$  is the  $k^{\text{th}}$  value of the 90 element voice metric table **V**.

### 4.3.5 Frame SNR and Long-Term Peak SNR Calculation

The instantaneous frame SNR,  $SNR$ , and long-term peak SNR,  $SNR_p(m)$ , are used to calibrate the responsiveness of the VAD decision. When the frame count is less than or equal to four ( $m \leq 4$ ) or the forced update flag (sec 4.3.10) is set (`fupdate_flag == TRUE`), then the SNR's are initialized as:

$$SNR_p(m) = SNR = 56 - 10 \log_{10} \left( \sum_{i=0}^{N_c-1} E_n(m, i) \right). \quad (4.9)$$

Otherwise, the instantaneous frame SNR is generated by:

$$SNR = 10 \log_{10} \left( \frac{1}{N_c} \sum_{i=0}^{N_c-1} 10^{\sigma(i)/10} \right) \quad (4.10)$$

and the long-term peak SNR is derived by the following expression:

$$SNR_p(m) = \begin{cases} 0.9SNR_p(m-1) + 0.1SNR, & SNR > SNR_p(m-1) \\ 0.998SNR_p(m-1) + 0.002SNR, & 0.625SNR_p(m-1) < SNR \leq SNR_p(m-1) \\ SNR_p(m-1), & otherwise \end{cases} \quad (4.11)$$

The long-term peak SNR is then quantized in 3 dB steps and limited to be between 0 and 19, as follows:

$$SNR_q = \max\{\min\{\lfloor SNR_p(m)/3 \rfloor, 19\}, 0\} \quad (4.12)$$

where  $\lfloor x \rfloor$  is the largest integer  $\leq x$  (floor function).

### 4.3.6 Negative SNR Sensitivity Bias

In order for the VAD decision to overcome the problem of being over-sensitive to fluctuating, non-stationary background noise conditions, a bias factor is used to increase the threshold on which the VAD decision is based. This bias factor is derived from an estimate of the variability of the background noise estimate. The variability estimate is further based on negative values of the instantaneous SNR. It is presumed that a negative SNR can only occur as a result of fluctuating background noise, and not from the presence of voice. Therefore, the bias factor  $\mu(m)$  is derived by first calculating the variability factor  $\psi(m)$  as:

$$\psi(m) = \begin{cases} 0.99\psi(m-1) + 0.01SNR^2, & SNR < 0 \\ \psi(m-1) & otherwise \end{cases} \quad (4.13)$$

which is then clamped in magnitude to  $0 \leq \psi(m) \leq 4.0$ . In addition, the variability factor is reset to zero when the frame count is less than or equal to four ( $m \leq 4$ ) or the forced update flag (sec 4.XX) is set (*fupdate\_flag* == TRUE). The bias factor  $\mu(m)$  is then calculated as:

$$\mu(m) = \max\{\lfloor 2.0(\psi(m) - 0.65) \rfloor, 0\} \quad (4.14)$$

### 4.3.7 VAD Decision

The quantized SNR  $SNR_q$  is used to determine the respective voice metric threshold  $v_{th}$ , hangover count  $h_{cnt}$ , and burst count threshold  $b_{th}$  parameters:

$$v_{th} = v_{table}(SNR_q), \quad h_{cnt} = h_{table}(SNR_q), \quad b_{th} = b_{table}(SNR_q) \quad (4.15)$$

where  $SNR_q$  is the index of the respective table elements. The VAD decision can then be made according to the following pseudocode:

```

if (  $v(m) > v_{th} + \mu(m)$  ) { /* if the voice metric > voice metric threshold*/
  VAD(m) = ON
   $b(m) = b(m-1) + 1$  /* increment burst counter */
  if (  $b(m) > b_{th}$  ) { /* compare counter with threshold */
     $h(m) = h_{cnt}$  /* set hangover */
  }
} else {
   $b(m) = 0$  /* clear burst counter */
   $h(m) = h(m-1) - 1$  /* decrement hangover /
  if (  $h(m) \leq 0$  ) { /* check for expired hangover /
    VAD(m) = OFF

```



```

        h(m) = 0
    } else {
        VAD(m) = ON          /* hangover not yet expired */
    }
}

```

Note that two 10 ms subframes are required to determine one VAD decision. The final decision is determined by the maximum of two subframe decisions, i.e.

```

if(VAD(m) == ON OR VAD(m-1) == ON) {
    VAD_flag = TRUE
} else {
    VAD_flag = FALSE
}

```

### 4.3.8 Spectral Deviation Estimator

The spectral deviation estimator is used as a safeguard against erroneous updates of the background noise estimate. If the spectral deviation of the input signal is too high, then the background noise estimate update may not be permitted. Calculate the estimated log power spectrum as:

$$E_{dB}(m, i) = 10 \log_{10}(E_{ch}(m, i)), \quad 0 \leq i < N_c \quad (4.16)$$

Then, calculate the estimated spectral deviation between the current power spectrum and the average long-term power spectral estimate:

$$\Delta_E(m) = \sum_{i=0}^{N_c-1} |E_{dB}(m, i) - \bar{E}_{dB}(m, i)| \quad (4.17)$$

where  $\bar{E}_{dB}(m)$  is the average long-term power spectral estimate calculated during the previous subframe, as defined in Equation 4.20. The initial value of  $\bar{E}_{dB}(m)$ , however, is defined to be the estimated log power spectrum of subframe 1, or:

$$\bar{E}_{dB}(m) = E_{dB}(m), \quad m = 1 \quad (4.18)$$

The exponential windowing factor,  $\alpha(m)$ , is then calculated as a function of the instantaneous frame SNR  $SNR$  and the long-term peak SNR  $SNR_p(m)$ , as:

$$\alpha(m) = \alpha_H - \left( (\alpha_H - \alpha_L) \frac{SNR_p(m) - SNR}{SNR_p(m)} \right), \quad (4.19)$$

which is then limited to  $\alpha_L \leq \alpha(m) \leq \alpha_H$ .

The average long-term power spectral estimate is then updated for the next frame by:

$$\bar{E}_{dB}(m+1, i) = \alpha(m) \bar{E}_{dB}(m, i) + (1 - \alpha(m)) E_{dB}(m, i), \quad 0 \leq i < N_c \quad (4.20)$$

where all the variables are previously defined.

### 4.3.9 Sinewave Detection

Next the *sinewave\_flag* is set TRUE when the spectral peak-to-average ratio  $\phi(m)$  is greater than 10, i.e.

$$\textit{sinewave\_flag} = \begin{cases} \text{TRUE}, & \phi(m) > 10 \\ \text{FALSE}, & \textit{otherwise} \end{cases} \quad (4.21)$$

where:

$$\phi(m) = 10 \log_{10} \left( \frac{\max\{E_{ch}(m, i)\}}{\sum_{j=0}^{N_c-1} E_{ch}(m, j) / N_c} \right), \quad 2 \leq i < N_c \quad (4.22)$$

### 4.3.10 Background Noise Update Decision

The following logic, as shown in pseudo-code, demonstrates how the noise estimate update decision is ultimately made:

```

/* Normal update logic */
update_flag = fupdate_flag = FALSE
if ( v(m) ≤ UPDATE_THLD and b(m) == 0 ) {
    update_flag = TRUE
    update_cnt = 0
}

/* Forced update logic (for over-riding the normal update logic)*/
else if (( E_tot > NOISE_FLOOR) and ( Δ_E(m) < DEV_THLD )
and ( sinewave_flag == FALSE ) and ( LTP_flag == FALSE)) {
    update_cnt = update_cnt + 1
    if ( update_cnt ≥ UPDATE_CNT_THLD )
        update_flag = fupdate_flag = TRUE
}

/* "Hysteresis" logic to prevent long-term creeping of update_cnt */

if ( update_cnt == last_update_cnt )
    hyster_cnt = hyster_cnt + 1
else
    hyster_cnt = 0
last_update_cnt = update_cnt
if ( hyster_cnt > HYSTER_CNT_THLD )
    update_cnt = 0
    
```

where  $E_{tot}$  is the total channel energy defined as:

$$E_{tot} = \sum_{i=0}^{N_c-1} E_{ch}(m,i) \tag{4.23}$$

and  $LTP\_flag$  is generated by the comparison of the long-term prediction gain to a constant threshold  $LTP\_THLD$ , i.e.:

$$LTP\_flag = \begin{cases} \text{TRUE,} & \beta > LTP\_THLD \\ \text{FALSE,} & \text{otherwise} \end{cases} \tag{4.24}$$

where the long-term prediction gain  $\beta$  is derived from the speech encoder[2] open-loop pitch predictor, and can be expressed as:

$$\beta = \frac{\sum_{n=0}^{N_p-1} s_w(n)s_w(n-k)}{\sum_{n=0}^{N-1} s_w^2(n)} \tag{4.25}$$

where  $s_w(n)$  is the weighted speech,  $k$  is the optimal open-loop lag, and  $N_p$  is the pitch analysis frame length. This expression is calculated in the speech encoder on the previous frame.

### 4.3.10 Background Noise Estimate Update

If (and only if) the update flag is set ( $update\_flag == \text{TRUE}$ ), then update the channel noise estimate for the next subframe by:

$$E_n(m+1,i) = \max\{E_{\min}, \alpha_n E_n(m,i) + (1-\alpha_n)E_{ch}(m,i)\}, \quad 0 \leq i < N_c \tag{4.26}$$

where  $E_{\min}$  is the minimum allowable channel energy, and  $\alpha_n$  is the channel noise smoothing factor. The channel noise estimate shall be initialized for each of the first four frames to the estimated channel energy, i.e.:

$$E_n(m,i) = \max\{E_{init}, E_{ch}(m,i)\}, \quad m \leq 4, \quad 0 \leq i < N_c, \quad (4.27)$$

where  $E_{init}$  is the minimum allowable channel noise initialization energy.

---

## 5 Computational details

A low level description has been prepared in form of ANSI C source code [].

---

## Annex A (informative): Document change history

SMG	SPEC	CR	PH	VERS	NEW_VERS	SUBJECT
29	06.94	A001	R98	7.0.0	7.1.0	AMR VAD/DTX - Merging of both AMR VAD options into one
29	06.94	A002	R98	7.0.0	7.1.0	AMR VAD/DTX Description - Alignment of 06.94 with the ANSI C
29	06.94	A003	R98	7.0.0	7.1.0	AMR VAD/DTX Description - Alignment of 06.94 with approved

---

# History

<b>Document history</b>			
V7.1.0	July 1999	One-step Approval Procedure	OAP 9952: 1999-07-28 to 1999-11-26