

ETSI EN 301 688 V1.1.1 (2000-07)

European Standard (Telecommunications series)

**Electromagnetic compatibility
and Radio spectrum Matters (ERM);
Technical characteristics and methods of measurement
for fixed and portable VHF equipment operating
on 121,5 MHz and 123,1 MHz**



Reference

DEN/ERM-RP01-031

Keywords

Maritime, radio, SAR

ETSI

650 Route des Lucioles
F-06921 Sophia Antipolis Cedex - FRANCE

Tel.: +33 4 92 94 42 00 Fax: +33 4 93 65 47 16

Siret N° 348 623 562 00017 - NAF 742 C
Association à but non lucratif enregistrée à la
Sous-Préfecture de Grasse (06) N° 7803/88

Important notice

Individual copies of the present document can be downloaded from:

<http://www.etsi.org>

The present document may be made available in more than one electronic version or in print. In any case of existing or perceived difference in contents between such versions, the reference version is the Portable Document Format (PDF).

In case of dispute, the reference shall be the printing on ETSI printers of the PDF version kept on a specific network drive within ETSI Secretariat.

Users of the present document should be aware that the document may be subject to revision or change of status.

Information on the current status of this and other ETSI documents is available at <http://www.etsi.org/tb/status/>

If you find errors in the present document, send your comment to:

editor@etsi.fr

Copyright Notification

No part may be reproduced except as authorized by written permission.
The copyright and the foregoing restriction extend to reproduction in all media.

© European Telecommunications Standards Institute 2000.
All rights reserved.

Contents

Intellectual Property Rights	6
Foreword	6
1 Scope	7
2 References	7
3 Symbols and abbreviations	7
3.1 Symbols	7
3.2 Abbreviations	8
4 General requirements	8
4.1 Construction	8
4.2 Controls	8
4.3 Operating frequencies	9
4.4 Labelling	9
4.5 Power source	9
5 Test conditions, power sources and ambient temperatures	10
5.1 Determination of the lower extreme test voltage	10
5.2 Normal and extreme test conditions	10
5.3 Test power source	10
5.4 Normal test conditions	10
5.4.1 Normal temperature and humidity	10
5.4.2 Normal power source	10
5.5 Extreme test conditions	11
5.5.1 Extreme temperatures	11
5.5.1.1 Upper extreme temperature	11
5.5.1.2 Lower extreme temperature	11
5.5.2 Extreme test power supply values	11
5.5.2.1 Upper extreme test voltage	11
5.5.2.2 Lower extreme test voltage	11
5.6 Procedure for tests at extreme temperatures	11
6 General conditions of measurements	12
6.1 Test connections	12
6.2 Arrangements for test signals applied to receiver input	12
6.3 Squelch	12
6.4 Normal test modulation	12
6.5 Artificial antenna	12
6.6 Test frequencies	12
6.7 Measurement uncertainty and interpretation of the measuring results	13
6.7.1 Measurement uncertainty	13
6.7.2 Interpretation of the measurement results	13
7 Environmental tests	13
7.1 Introduction	13
7.2 Procedure	13
7.3 Performance check	14
7.4 Drop test on hard surface	14
7.4.1 Definition	14
7.4.2 Method of measurement	14
7.4.3 Limit	14
7.5 Vibration test	14
7.5.1 Method of measurement	14
7.5.2 Limits	15
7.6 Temperature tests	15
7.6.1 General	15

7.6.2	Dry heat cycle	15
7.6.2.1	Method of measurement	15
7.6.2.2	Limits	15
7.6.3	Damp heat cycle.....	15
7.6.3.1	Method of measurement	15
7.6.3.2	Limits	16
7.6.4	Low temperature cycle.....	16
7.6.4.1	Method of measurement	16
7.6.4.2	Limits	16
7.7	Immersion test	16
7.7.1	Method of measurement.....	16
7.7.2	Requirements	16
8	Transmitter	17
8.1	Carrier power.....	17
8.1.1	Definition.....	17
8.1.2	Method of measurement.....	17
8.1.3	Limit	17
8.2	Frequency error	17
8.2.1	Definition.....	17
8.2.2	Method of measurement.....	17
8.2.3	Limit	17
8.3	Modulation of the transmitter.....	17
8.3.1	Definition.....	17
8.3.2	Method of measurement.....	17
8.3.3	Limit	18
8.4	Conducted spurious emissions conveyed to the antenna	18
8.4.1	Definition.....	18
8.4.2	Method of measurement.....	18
8.4.3	Limit	18
8.5	Cabinet radiation	18
8.5.1	Definitions	18
8.5.2	Method of measurement.....	18
8.5.3	Limits.....	19
9	Receiver.....	19
9.1	Harmonic distortion and audio frequency output power.....	19
9.1.1	Definition.....	19
9.1.2	Method of measurement.....	20
9.1.3	Limit	20
9.2	Maximum usable sensitivity	20
9.2.1	Definition.....	20
9.2.2	Method of measurement.....	20
9.2.3	Limit	20
9.3	Spurious response rejection.....	20
9.3.1	Definition.....	21
9.3.2	Introduction to the method of measurement.....	21
9.3.3	Method of search of the limited frequency range.....	21
9.3.4	Method of measurement.....	21
9.3.5	Limit	22
9.4	Conducted spurious emissions.....	22
9.4.1	Definition.....	22
9.4.2	Method of measurement.....	22
9.4.3	Limit	22
Annex A (normative): Radiated measurements.....		23
A.1	Test sites and general arrangements for measurements involving the use of radiated fields	23
A.1.1	Outdoor test site	23
A.1.2	Test antenna.....	23
A.1.3	Substitution antenna	24
A.1.4	Optional additional indoor site	24

A.2	Guidance on the use of radiation test sites.....	25
A.2.1	Measuring distance.....	25
A.2.2	Test antenna.....	25
A.2.3	Substitution antenna.....	25
A.2.4	Artificial antenna.....	26
A.2.5	Auxiliary cables.....	26
A.2.6	Acoustic measuring arrangement.....	26
A.3	Further optional alternative indoor test site using an anechoic chamber.....	26
A.3.1	Example of the construction of a shielded anechoic chamber.....	27
A.3.2	Influence of parasitic reflections in anechoic chambers.....	29
A.3.3	Calibration of the shielded anechoic chamber.....	29
	History.....	30

Intellectual Property Rights

IPRs essential or potentially essential to the present document may have been declared to ETSI. The information pertaining to these essential IPRs, if any, is publicly available for **ETSI members and non-members**, and can be found in ETSI SR 000 314: "*Intellectual Property Rights (IPRs); Essential, or potentially Essential, IPRs notified to ETSI in respect of ETSI standards*", which is available from the ETSI Secretariat. Latest updates are available on the ETSI Web server (<http://www.etsi.org/ipr>).

Pursuant to the ETSI IPR Policy, no investigation, including IPR searches, has been carried out by ETSI. No guarantee can be given as to the existence of other IPRs not referenced in ETSI SR 000 314 (or the updates on the ETSI Web server) which are, or may be, or may become, essential to the present document.

Foreword

This European Standard (Telecommunications series) has been produced by ETSI Technical Committee Electromagnetic compatibility and Radio spectrum Matters (ERM).

National transposition dates	
Date of adoption of this EN:	26 May 2000
Date of latest announcement of this EN (doa):	31 August 2000
Date of latest publication of new National Standard or endorsement of this EN (dop/e):	28 February 2001
Date of withdrawal of any conflicting National Standard (dow):	28 February 2001

1 Scope

The present document specifies the minimum technical requirements for maritime two-way AM VHF radiotelephone apparatus for communications between ships in distress and rescuing aircraft. The standard incorporates relevant provisions of the ITU Radio Regulations [1], of IMO Assembly Resolutions [2] and of Annex 10 to the ICAO Convention [3].

The maritime VHF equipment described in the present document is intended for communications on the aeronautical emergency frequencies 121,5 MHz and 123,1 MHz only.

The present document is applicable to portable and fixed installed equipment.

The intention of the present document is to define equipment that in all respects have mechanical and electrical design, construction and finish in conformance with good engineering practice and that is suitable for use on board ships at sea in distress situations.

2 References

The following documents contain provisions which, through reference in this text, constitute provisions of the present document.

- References are either specific (identified by date of publication, edition number, version number, etc.) or non-specific.
- For a specific reference, subsequent revisions do not apply.
- For a non-specific reference, the latest version applies.
- A non-specific reference to an ETS shall also be taken to refer to later versions published as an EN with the same number.

- | | |
|-----|---|
| [1] | ITU Radio Regulations. |
| [2] | IMO International Convention for the Safety Of Life At Sea (SOLAS). |
| [3] | ICAO Convention on International Civil Aviation, annex 10. |
| [4] | ETSI ETS 300 225: "Radio Equipment and Systems (RES); Technical characteristics and methods of measurement for survival craft portable VHF radiotelephone apparatus". |
| [5] | ISO/R 694: "Positioning of magnetic compasses in ships". |
| [6] | EUROCAE ED-14C: "Environmental conditions and test procedures for airborne equipment". |
| [7] | ETSI ETR 028: "Radio Equipment and Systems (RES); Uncertainties in the measurement of mobile radio equipment characteristics". |

3 Symbols and abbreviations

3.1 Symbols

For the purposes of the present document, the following symbols apply:

A3E	amplitude modulation with double sideband and full carrier
dBA	acoustic level in dB relative to 2×10^{-5} Pa
dBd	antenna gain in dB relative to dipole radiation

3.2 Abbreviations

For the purposes of the present document, the following abbreviations apply:

AM	Amplitude Modulation
emf	electro-motive force
ERP	Effective Radiated Power
EUT	Equipment Under Test
pep	peak envelope power
RF	Radio Frequency
rms	root mean square
SINAD	Signal + Noise + Distortion/Noise + Distortion
VHF	Very High Frequency

4 General requirements

4.1 Construction

Portable equipment shall in one unit comprise at least transmitter, receiver, antenna, battery, operating controls including press-to-transmit switch, microphone and loudspeaker.

For portable equipment, the antenna gain shall be declared by the manufacturer and shall be at least -12 dBd.

Equipment intended for fixed installations shall have an 50 Ω RF socket.

Portable equipment shall be of small size and light in weight.

Portable equipment shall include provision for the connection of external microphone and headset.

The equipment shall have a colour which distinguishes it from the portable VHF equipment specified in ETS 300 225 [4].

The equipment shall be operational within 5 seconds of switching on.

Any part of the equipment required to be checked during inspection or maintenance operations as laid down by the manufacturer, shall be readily accessible.

4.2 Controls

The number of controls shall be the minimum necessary for simple operation. With the possible exception of channel selection, it shall be possible to operate the equipment using only one hand.

The equipment shall be provided with an on-off switch and a visual indication that the equipment is switched on.

The equipment shall be provided with a manual volume control by which the audio output may be varied.

The press-to-transmit switch shall be non-locking and return to standby (receive) mode when released. The time necessary to change from transmission to reception, or vice versa, shall not exceed 0,3 seconds.

The equipment shall have a channel selector and shall clearly indicate which frequency the equipment is set to. The channel switching arrangement shall be such that the time necessary to change from one frequency to the other does not exceed 5 seconds. It shall not be possible to transmit during channel switching operations. Independent selection of transmitting and receiving frequencies shall not be possible. In the transmission mode, the output of the receiver shall be muted.

If the equipment includes a test facility, the switch which operates this facility shall be so designed that it automatically returns to normal position when released.

4.3 Operating frequencies

The equipment shall be capable of operating on the single frequency channels 121,5 MHz and 123,1 MHz only, with manual control (simplex).

The equipment shall operate with class of emission A3E.

4.4 Labelling

The labels on the equipment shall be permanently fixed to the exterior of the equipment.

All controls and indicators shall be clearly labelled.

The labelling shall at least comprise the following information:

- text containing the words: "Only for emergency communications with aircraft";
- brief operating instructions;
- type designation of the equipment and serial number;
- expiry date for any primary batteries;
- for portable equipment, compass safe distance, according to ISO Recommendation 694 Method B [5] or Eurocae [6].

4.5 Power source

For portable equipment, the source of energy shall be a primary battery that may be replaceable by the user without the use of special tools and without degrading the performance of the equipment. In addition, provisions may be made to operate the equipment using an external source of electrical energy.

Fixed radio installation should be powered from the ship's main source of electrical energy. In addition, it should be possible to operate the installation from an alternative source of electrical energy. Alternatively, the source of energy may be a primary battery integrated in the equipment and may be replaceable by the user.

Primary batteries shall have a shelf life of at least 2 years.

Provisions shall be made for protecting the equipment from damage due to accidental reversal of the polarity of the battery or of any external power supply.

The capacity of the primary battery shall be sufficient to operate the equipment continuously for at least 10 hours at normal temperature condition (see subclause 5.4.1) with the following duty cycle:

- 6 seconds transmit without modulation followed by 6 seconds reception with an RF input signal at the nominal frequency of the receiver at a level of +60 dB μ V using normal test modulation (subclause 6.4) with the audio volume control set to give minimum 200 mW output power followed by 48 seconds reception without input signal under muted condition (operational squelch condition).

5 Test conditions, power sources and ambient temperatures

5.1 Determination of the lower extreme test voltage

When determining the capacity of the primary battery, the battery voltage shall be measured at the end of a duration test. During this duration test, when activated, the transmitter should be modulated to give maximum output power (pep at 100 % modulation). However, this measurement would require an acoustic modulation signal and is complicated to perform. This test may therefore be performed with no modulation (unmodulated carrier) of the transmitter during the periods when the transmitter is activated and it is estimated that an 8 hours duration test with the transmitter modulated to 100 % modulation depth corresponds to a 10 hours duration test with the transmitter keyed without modulation. The equipment shall be operated with the following duty cycle:

- 6 seconds transmission without modulation followed by 6 seconds reception with an RF input signal at the nominal frequency of the receiver at a level of +60 dB μ V using normal test modulation (subclause 6.4) with the audio volume control set to give minimum 200 mW output power followed by 48 seconds reception without input signal under muted condition (operational squelch condition).

The lower extreme test voltage is the voltage of the battery at the end of this duration test measured with the transmitter activated.

5.2 Normal and extreme test conditions

Testing of the equipment shall be made under normal test conditions and also, where stated, under extreme test conditions.

5.3 Test power source

During testing, the equipment shall be supplied from a test power source capable of producing normal and extreme test voltages as specified in subclauses 5.4.2 and 5.5.2. The test power source shall only be used in measurements where its effect on the test results are negligible. The power source voltage shall be measured at the input terminals of the equipment.

During testing, the power source voltages shall be maintained within a tolerance of ± 3 % relative to the voltage level at the beginning of each test.

5.4 Normal test conditions

5.4.1 Normal temperature and humidity

The normal temperature and humidity conditions for tests shall be a combination of temperature and humidity within the following limits:

- Temperature +15°C to +35°C;
- Relative humidity 20 % to 75 %.

5.4.2 Normal power source

For portable equipment, the normal test voltage shall be the nominal voltage of the battery as declared by the manufacturer.

For fixed installation equipment, the normal test voltage shall be the nominal mains voltage. The frequency of the test voltage shall be 50 Hz \pm 1 Hz.

5.5 Extreme test conditions

5.5.1 Extreme temperatures

5.5.1.1 Upper extreme temperature

Tests at the upper extreme temperature shall be made at a temperature of +55°C.

5.5.1.2 Lower extreme temperature

Tests at the lower extreme temperature shall be made at a temperature of -20°C.

5.5.2 Extreme test power supply values

5.5.2.1 Upper extreme test voltage

For portable equipment, the upper extreme test voltage shall be determined in each case and should be the voltage corresponding to the voltage that the battery gives at the upper extreme temperature at the beginning of the battery test cycle with a load equal to that of the equipment in the transmit condition without modulation.

For fixed installation equipment, the upper extreme test voltage shall be the nominal mains voltage +10 %. The frequency shall be 50 Hz \pm 1 Hz.

5.5.2.2 Lower extreme test voltage

The equipment fitted with an unused primary battery shall be placed in a climatic chamber and cooled to -20°C allowing a stabilization period of 2 hours. The equipment shall be activated as described in subclause 4.5. After this test the battery voltage shall be measured during equipment transmission. This voltage shall be taken as the lower extreme test voltage, and shall be measured before disconnecting the load.

For fixed installation equipment, the lower extreme test voltage shall be the nominal mains voltage -10 %. The frequency shall be 50 Hz \pm 1 Hz.

5.6 Procedure for tests at extreme temperatures

The equipment shall be switched off during the temperature-stabilizing periods.

Before conducting tests at the upper temperature, the equipment shall be placed in the test chamber and left until thermal equilibrium is reached. The equipment shall then be switched on for half an hour during which the transmitter shall be keyed with a duty cycle of 5 minutes transmission and 5 minutes reception.

For tests at the lower temperature, the equipment shall be left in the test chamber until thermal equilibrium is reached and shall then be switched to the standby or receive position for 1 minute.

6 General conditions of measurements

6.1 Test connections

For the purpose of testing, the equipment shall be provided with suitable connections to test points within the equipment, which allow easy access to:

- the transmitter output (for 50 Ω connection);
- the receiver input (for 50 Ω connection);
- the transmitter audio input(s);
- the receiver audio output(s);
- the push-to-talk switch;
- power supply input.

6.2 Arrangements for test signals applied to receiver input

Test signal generators shall be connected to the receiver input in such a way that the impedance presented to the receiver input is 50 Ω , irrespective of whether one or more test signals are applied to the receiver simultaneously.

The levels of the test signals shall be expressed in terms of the electromotive force (emf) at the terminals to be connected to the receiver.

The effects of any intermodulation product and noise product in the test signal generators shall be negligible.

The nominal frequency of the receiver is the carrier frequency of the selected channel.

6.3 Squelch

Unless otherwise stated, the receiver squelch facility, if any, shall be made inoperative for the duration of the conformance tests.

6.4 Normal test modulation

For signals applied to the receiver, the normal test modulation frequency shall be 1 kHz and the modulation depth shall be 30 %, unless otherwise stated.

6.5 Artificial antenna

When tests are conducted with an artificial antenna, this shall be a 50 Ω non-reactive, non-radiating load.

6.6 Test frequencies

Tests shall be made on 123,1 MHz, unless otherwise stated. When testing on 121,5 MHz, care should be taken to avoid radiation that could cause false distress alerts.

6.7 Measurement uncertainty and interpretation of the measuring results

6.7.1 Measurement uncertainty

Absolute measurement uncertainties: maximum values

RF frequency	$\pm 1 \times 10^{-7}$
RF power	$\pm 0,75$ dB
Audio output power	$\pm 0,5$ dB
Sensitivity at 12 dB SINAD	± 3 dB
Two signal measurement	± 4 dB

For the test methods according to this report the uncertainty figures are valid to a confidence level of 95 % calculated according to the methods described in ETR 028 [7].

6.7.2 Interpretation of the measurement results

The interpretation of the results recorded in a test report for the measurements described in this report shall be as follows:

- the measured value related to the corresponding limit will be used to decide whether an equipment meets the proposed limits of this report;
- the measurement uncertainty value for the measurement of each parameter should be included in the test report;
- the recorded value of the measurement uncertainty should be, for each measurement, equal to or lower than the maximum values given above.

7 Environmental tests

7.1 Introduction

The tests in this clause are performed in order to simulate the environment in which the equipment is intended to operate.

7.2 Procedure

All test with respect to the requirements of the present document shall be carried out on a single sample of the EUT.

Environmental tests shall be carried out before tests with respect to the other requirements of the present document.

The following tests shall be carried out in the order they appear.

Unless otherwise stated, the equipment shall be connected to an electrical power source only during the periods for which it is specified that electrical tests shall be carried out. These shall be done with normal test voltage.

7.3 Performance check

The term performance check shall be taken to mean an inspection to check if there is any visible damage or deterioration and the following measurements:

- for the transmitter: carrier frequency power and frequency error (subclause 8.1 and 8.2);
- for the receiver: maximum usable sensitivity (subclause 9.2).

7.4 Drop test on hard surface

This test is applicable only for portable equipment.

7.4.1 Definition

The immunity against the effects of dropping is the ability of the equipment to maintain the specified mechanical and electrical performance after being subjected to a series of drops on a hard wooden test surface.

7.4.2 Method of measurement

The test shall consist of a series of 6 drops, one on each surface of the equipment. During the test the equipment shall be fitted with a suitable set of batteries and antenna but it shall be switched off. The test shall be carried out under normal temperature and humidity conditions.

The hard wooden test surface should consist of a piece of solid hard wood with a thickness of minimum 15 cm and a mass of 30 kg or more.

The height of the lowest part of the equipment under test relative to the test surface at the moment of release shall be 1 metre.

Equipment shall be subjected to this test configured for use as in operational circumstances.

If the equipment is to be used with, for example, a separate microphone and/or loudspeaker, the test shall be carried out for those accessories separately.

Following the test, the equipment shall be subjected to a performance check.

7.4.3 Limit

The limits for the performance check shall be met.

7.5 Vibration test

7.5.1 Method of measurement

For portable equipment, the equipment with any accessory for storing, shall be clamped to the vibration table as it is intended to be stored on board a ship.

Equipment for fixed installations shall be clamped to the vibration table in its intended normal installation attitude.

The equipment shall be subjected to sinusoidal vertical vibration at all frequencies between:

- 5 Hz and 13,2 Hz with an excursion of $\pm 1 \text{ mm} \pm 10 \%$ (7 m/s^2 maximum acceleration at 13,2 Hz)
- 13,2 Hz and 100 Hz with constant acceleration of 7 m/s^2 .

The frequency sweep rate shall be slow enough to allow detection of resonances in any part of the equipment.

A resonance search shall be carried out throughout the test. If any resonance of the equipment with $Q \geq 5$ relative to the base of the vibration table is measured, the equipment shall be subjected to a 2 hours vibration endurance test at each of the found resonance frequencies at the level specified above. If no resonance or resonances with $Q < 5$ occur, the 2 hours endurance test shall be carried out at the frequency 30 Hz with acceleration 7 m/s^2 .

Performance check shall be carried out at least once during the endurance test period and once before the end of each endurance period.

The procedure shall be repeated with vibration in each of the two mutually perpendicular directions in the horizontal plane.

After conducting the vibration tests, the equipment shall be inspected for any mechanical deterioration.

7.5.2 Limits

The limits for the performance check shall be met.

There shall be no visible deterioration of the equipment.

7.6 Temperature tests

7.6.1 General

The maximum rate of raising or reducing the temperature of the chamber in which the equipment is being tested shall be $1^\circ\text{C}/\text{min}$.

7.6.2 Dry heat cycle

7.6.2.1 Method of measurement

The equipment shall be placed in a chamber at normal temperature. The temperature shall then be raised to, and maintained at, $+70^\circ\text{C} (\pm 3^\circ\text{C})$ for a period of at least 10 hours. After this period the chamber shall be cooled to $55^\circ\text{C} (\pm 3^\circ\text{C})$. The cooling of the chamber shall be completed within 30 minutes.

The equipment shall then be switched on and be kept working continuously for a period of 2 hours. The transmitter shall be keyed with a duty cycle of 5 minutes transmission and 5 minutes reception. The equipment shall be subjected to a performance check during the 2 hours period.

The temperature of the chamber shall be maintained at $+55^\circ\text{C} (\pm 3^\circ\text{C})$ during the 2 hours period.

At the end of the test, and with the equipment still in the chamber, the chamber shall be brought to room temperature in not less than 1 hour. The equipment shall then be exposed to normal room temperature and humidity for not less than 3 hours before the next test is carried out.

7.6.2.2 Limits

The limits for the performance check shall be met.

7.6.3 Damp heat cycle

7.6.3.1 Method of measurement

The equipment shall be placed in a chamber at normal room temperature and humidity and then, steadily over a period $3 (\pm 0,5)$ hours, the chamber shall be heated to $+40^\circ\text{C} (\pm 2^\circ\text{C})$ and over the same period brought to a relative humidity of 93 % (± 3 %) so that excessive condensation is avoided. These conditions shall be maintained for a period of at least 10 hours.

30 minutes later the equipment shall be switched on and be kept working continuously for a period of 2 hours. The transmitter shall be keyed with a duty cycle of 5 minutes transmission and 5 minutes reception.

The equipment shall be subjected to a performance check during the 2 hours period.

The temperature and relative humidity of the chamber shall be maintained at $+40^{\circ} \pm 2^{\circ} \text{C}$ and $93 \% \pm 3 \%$ during the 2 hours and 30 minutes period.

At the end of the test, and with the equipment still in the chamber, the chamber shall be brought to room temperature in not less than 1 hour. The equipment shall then be exposed to normal room temperature and humidity for not less than 3 hours, or until moisture has dispersed, whichever is longer, before the next test is carried out.

7.6.3.2 Limits

The limits for the performance check shall be fulfilled.

7.6.4 Low temperature cycle

7.6.4.1 Method of measurement

The equipment shall be placed in a chamber at normal room temperature. Then the temperature shall be reduced to, and maintained at, $-25^{\circ}\text{C} (\pm 3^{\circ}\text{C})$ for a period of at least 10 hours.

The chamber shall be warmed up to $-20^{\circ}\text{C} (\pm 3^{\circ}\text{C})$. The warming of the chamber shall be completed within 30 minutes (± 5).

The temperature of the chamber shall be then maintained at $-20^{\circ}\text{C} (\pm 3^{\circ}\text{C})$ during a period of 1 hour and 30 minutes.

The equipment shall be subjected to a performance check during the last 30 minutes of the test.

At the end of the test, and with the equipment still in the chamber, the chamber shall be brought to room temperature in not less than 1 hour. The equipment shall then be exposed to normal room temperature for not less than 3 hours, or until moisture has dispersed, which ever is longer, before the next test is carried out.

Throughout the test the equipment shall be in the receive condition.

7.6.4.2 Limits

The limits for the performance check shall be fulfilled.

7.7 Immersion test

This test is only applicable to portable equipment.

7.7.1 Method of measurement

A hydraulic pressure of 10 kPa, corresponding to a depth of 1 meters, shall be applied for a period of 5 minutes.

Within 2 minutes after the end of the test period, the equipment shall be subjected to a performance check and be inspected for damage and visible ingress of water.

Following inspection, the equipment shall be resealed in accordance with the manufacturer's instructions.

7.7.2 Requirements

The requirements of the performance check shall be met.

No damage or ingress of water shall be visible to the naked eye.

8 Transmitter

8.1 Carrier power

8.1.1 Definition

The carrier power is the mean power delivered to the artificial antenna during one radio frequency cycle in the absence of modulation.

8.1.2 Method of measurement

The transmitter shall be connected to an artificial antenna (subclause 6.5) and activated without modulation. The power delivered to the antenna shall be measured.

The measurement shall be made on both 121,5 MHz and 123,1 MHz under normal test conditions and also under extreme test conditions.

8.1.3 Limit

The carrier power shall be between 50mW and 1,5W ERP.

For fixed installations, assume antenna gain of 0 dBd.

For portable equipment, apply the antenna gain as declared by the manufacturer.

8.2 Frequency error

8.2.1 Definition

The frequency error is the difference between the measured carrier frequency and its nominal value.

8.2.2 Method of measurement

The transmitter shall be connected to an artificial antenna (subclause 6.5) and activated without modulation. The carrier frequency shall be measured under normal test conditions and also under extreme test conditions.

8.2.3 Limit

The frequency error shall be less than ± 2 kHz.

8.3 Modulation of the transmitter

8.3.1 Definition

The modulation of the transmitter is the depth of modulation that is produced at the transmitter output when a certain sound level is applied to the microphone.

8.3.2 Method of measurement

An acoustic signal with a frequency of 1 kHz and a level of 94 dBA ± 3 dB at the microphone shall be applied. The depth of modulation at the transmitter output and the distortion in the recovered transmit audio shall be measured.

8.3.3 Limit

The depth of modulation shall be at least 70 %.

The distortion shall be less than 10 %.

8.4. Conducted spurious emissions conveyed to the antenna.

8.4.1 Definition

Conducted spurious emissions are emissions on a frequency or frequencies which are outside the necessary bandwidth and the level of which may be reduced without affecting the corresponding transmission of information. Spurious emissions include harmonic emissions, parasitic emissions, intermodulation products and frequency conversion products, but exclude out of band emissions.

8.4.2 Method of measurement

Conducted spurious emissions shall be measured with the unmodulated transmitter connected to the artificial antenna (subclause 6.5).

The measurements shall be made over the range from 9 kHz to 2 GHz, excluding the channel on which the transmitter is operating and its adjacent channels.

The measurements shall be made using a selective measuring devices such as a tuned radio measuring instrument or a spectrum analyser.

8.4.3 Limit

The power of any conducted spurious emission on any discrete frequency shall not exceed 0,25 μ W.

8.5 Cabinet radiation

8.5.1 Definitions

Cabinet radiation consists of emissions radiated by the equipment cabinet and structures. These spurious emissions are measured in terms of effective radiated power (ERP).

8.5.2 Method of measurement

On a test site, selected from annex A, the equipment shall be placed at the specified height on a non-conducting support and in position closest to normal use as declared by the manufacturer.

The EUT antenna connector shall be connected to a non-radiating load.

The test antenna shall be orientated for vertical polarization.

The output of the test antenna shall be connected to a measuring receiver.

The transmitter shall be switched on without modulation, and the measuring receiver shall be tuned over the frequency range 30 MHz to 2 GHz, except for the channel on which the transmitter is intended to operate and its adjacent channels.

At each frequency at which a spurious component is detected:

- a) the test antenna shall be raised and lowered through the specified range of heights until a maximum signal level is detected on the measuring receiver;
- b) the EUT shall be rotated through 360° in the horizontal plane, until the maximum signal level is detected by the measuring receiver;
- c) the maximum signal level detected by the measuring receiver shall be noted;
- d) the transmitter shall be replaced by a calibrated substitution antenna as defined in annex A;
- e) the substitution antenna shall be orientated for vertical polarization and the length of the substitution antenna shall be adjusted to correspond to the frequency of the spurious component detected;
- f) the substitution antenna shall be connected to a calibrated signal generator;
- g) the frequency of the calibrated signal generator shall be set to the frequency of the spurious component detected;
- h) if necessary, the input attenuator setting of the measuring receiver shall be adjusted in order to increase the sensitivity of the measuring receiver;
- i) the test antenna shall be raised and lowered through the specified range of heights to ensure that the maximum signal is received;
- j) the input signal to the substitution antenna shall be adjusted to produce a level detected by the measuring receiver, equal to the level noted while the spurious component was measured (taking into account any change of input attenuator setting of the measuring receiver);
- k) the input power level to the substitution antenna shall be recorded;
- l) the measurement shall be repeated with the test antenna and the substitution antenna orientated for horizontal polarization;
- m) at each spurious emission frequency the ERP is the larger of the two power levels recorded, for horizontal and vertical polarization at the input to the substitution antenna. The measurement shall be corrected for the gain of the substitution antenna, in dBd, and for any change to the input attenuation of the measuring receiver between the EUT and substitution phases of the measurement;
- n) the measurements shall be repeated with the EUT on stand-by.

8.5.3 Limits

When the transmitter is in stand-by the cabinet radiation shall not exceed 2 nW.

When the transmitter is in operation the cabinet radiation shall not exceed 0,25 µW.

9 Receiver

9.1 Harmonic distortion and audio frequency output power

9.1.1 Definition

The harmonic distortion at the receiver output is defined as the ratio, expressed as a percentage, of the total rms voltage of all the harmonic components of the modulation audio frequency to the total rms voltage of the signal delivered by the receiver.

The audio-frequency output power is the maximum power available at the output, for which the harmonic distortion is below a certain level.

9.1.2 Method of measurement

A test signal with normal test modulation (subclause 6.4) and with a level of +120 dB μ V at one of the two nominal frequencies of the receiver shall be applied to the receiver input.

The output of the receiver shall be connected to a resistive load simulating the receiver's operating load.

The harmonic distortion and output power shall be measured.

The audio frequency volume control of the receiver shall be set so that the harmonic distortion is 10 % or so that the volume control is in the maximum position whichever comes first.

9.1.3 Limit

The audio frequency output power shall be at least 200 mW.

9.2 Maximum usable sensitivity

9.2.1 Definition

The maximum usable sensitivity of the receiver is the minimum level of the RF signal at the nominal frequency of the receiver which, when applied to the receiver input with normal test modulation, will produce an audio frequency output power equal to at least 50 % of the maximum audio frequency output power (see subclause 9.1) and a SINAD ratio of 12 dB.

9.2.2 Method of measurement

A test signal modulated with normal test modulation (subclause 6.4) at one of the two nominal frequencies of the receiver shall be applied to the receiver input.

The output of the receiver shall be connected to a resistive load simulating the receiver's operating load.

The SINAD ratio shall be measured.

The level of the test signal should be adjusted until a SINAD ratio of 12 dB is obtained, using the receiver's audio frequency power control adjusted to produce 50 % of the maximum audio frequency output power measured in subclause 9.1.

The measurement should be made on both 121,5 MHz and 123,1 MHz under normal test conditions and also under extreme test conditions.

9.2.3 Limit

The maximum usable sensitivity shall be better than + 30 dB μ V.

9.3 Spurious response rejection

Spurious responses may occur at all frequencies throughout the frequency spectrum and the requirements of the present document shall be met for all frequencies. However, for practical reasons the measurements for type testing shall be performed as specified in the present document. More specifically, this method of measurement is not intended to capture all spurious responses but selects those that have a high probability of being present. However, in a limited frequency range close to the nominal frequency of the receiver, it has been considered impossible to determine the probability of spurious responses and therefore a search shall be performed over this limited frequency range. This method provides a high degree of confidence that the equipment also meets the requirements at frequencies not being measured.

9.3.1 Definition

The spurious response rejection is a measure of the capability of the receiver to discriminate between the wanted modulated signal at the nominal frequency and an unwanted signal at any other frequency at which a response is obtained.

9.3.2 Introduction to the method of measurement

To determine the frequencies at which spurious responses can occur the following calculations shall be made:

a) Calculation of the limited frequency range

The limited frequency range is defined as the frequency of the local oscillator signal (f_{LO}) applied to the first mixer of the receiver plus or minus the sum of the intermediate frequencies ($f_{i1} \dots f_{in}$) and a half of the maximum frequency range (fr_m) of the receiver.

Hence the frequency f_L of the limited frequency range is

$$f_{LO} - \sum_{j=1..n} f_{ij} - fr_m/2 \leq f_L \leq f_{LO} + \sum_{j=1..n} f_{ij} + fr_m/2$$

b) Calculation of frequencies outside the limited frequency range

The frequencies outside the limited frequency range determined in a) are equal to the harmonics of the frequency of the local oscillator signal (f_{LO}) applied to the first mixer of the receiver plus or minus the first intermediate frequency (f_{i1}) of the receiver.

Hence the frequencies of these spurious responses are $nf_{LO} \pm f_{i1}$, where n is an integer greater than or equal to 2.

The measurement of the first image response of the receiver shall initially be made to verify the calculation of spurious response frequencies.

For calculations a) and b), the manufacturer shall state the frequency of the receiver, the frequency of the local oscillator signal (f_{LO}) applied to the first mixer of the receiver, the intermediate frequencies (f_{i1} , f_{i2} etc.), and the maximum frequency range (fr_m) of the receiver.

9.3.3 Method of search of the limited frequency range

The test signal shall be at the nominal frequency and amplitude modulated by 1 kHz at a modulation depth of 30 %.

The test signal shall be adjusted to a level corresponding to a SINAD ratio of 12 dB and recorded as the reference level.

The input level of the test signal shall then be adjusted to 80 dB above the reference level.

The frequency shall be varied continuously over the limited frequency range determined in subclause 9.3.2 a) and over the frequencies outside the frequency range in accordance with the calculations in subclause 9.3.2 b).

The frequency of any spurious responses detected during the search shall be recorded for the use in the measurement described in the following subclause.

9.3.4 Method of measurement

The test signal from a signal generator shall be applied to the receiver input. A rms voltmeter shall be connected to the receiver output.

The test signal shall have normal test modulation (subclause 6.4) at the nominal frequency of the receiver.

The RF signal level shall be adjusted to produce a SINAD ratio according of 12 dB, recorded as the reference level.

The signal generator shall then be tuned to a spurious response frequency detected according to subclause 9.3.3 and modulated with normal test modulation.

The level of the RF signal is increased until the receiver output signal produces an SINAD ratio of 12 dB.

This RF signal level shall be recorded as the unwanted signal level.

The spurious response rejection ratio is the ratio in dB of the unwanted signal level to the reference level.

This measurement shall be made for each frequency detected according to subclause 9.3.3.

9.3.5 Limit

At any frequency separated from the nominal frequency of the receiver by more than two channels, the spurious response rejection ratio shall be not less than 70 dB.

9.4 Conducted spurious emissions

9.4.1 Definition

Conducted spurious emissions from the receiver are defined as components at any frequency, conducted to the antenna of the equipment.

9.4.2 Method of measurement

Conducted spurious emissions shall be measured with the receiver switched on and connected to the artificial antenna (subclause 6.5).

The measurements shall be made over the range from 9 kHz to 2 GHz.

The measurements for each spurious emission shall be made using a selective measuring device such as a tuned radio measuring instrument or a spectrum analyser.

9.4.3 Limit

The power of any conducted spurious emission shall not exceed 2 nW.

Annex A (normative): Radiated measurements

A.1 Test sites and general arrangements for measurements involving the use of radiated fields

A.1.1 Outdoor test site

The outdoor test site shall be on a reasonably level surface or ground. At one point on the site, a ground plane of at least 5 m diameter shall be provided. In the middle of this ground plane, a non-conducting support, capable of rotation through 360° in the horizontal plane, shall be used to support the test sample at 1,5 m above the ground plane. The test site shall be large enough to allow the erection of a measuring or transmitting antenna at a distance of $\lambda/2$ or 3 m whichever is the greater. The distance actually used shall be recorded with the results of the tests carried out on the site.

Sufficient precautions shall be taken to ensure that reflections from extraneous objects adjacent to the site and ground reflections do not degrade the measurements results.

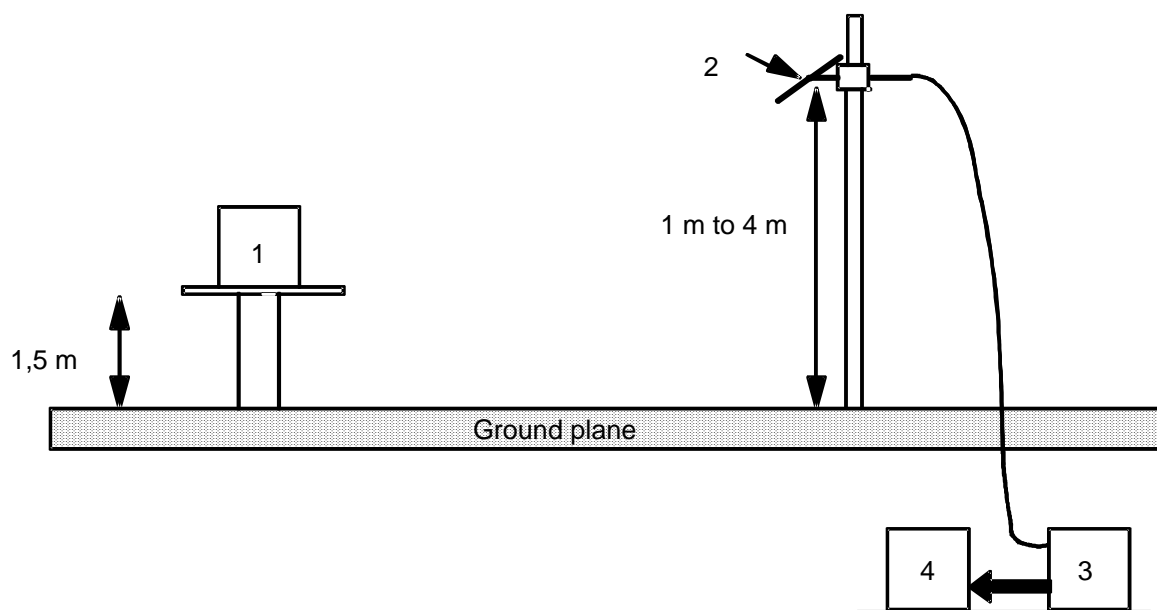

Key:

- 1 Equipment under test
- 2 Test antenna
- 3 High pass filter (necessary for strong fundamental Tx radiation)
- 4 Spectrum analyser or measuring receiver

Figure A.1

A.1.2 Test antenna

The test antenna is used to detect the radiation from both the test sample and the substitution antenna, when the site is used for radiation measurements; where necessary, it is used as a transmitting antenna, when the site is used for the measurement of receiver characteristics.

This antenna is mounted on a support such as to allow the antenna to be used in either horizontal or vertical polarization and for the height of its centre above ground to be varied over the range 1 m to 4 m. Preferably a test antenna with pronounced directivity should be used. The size of the test antenna along the measurement axis shall not exceed 20 % of the measuring distance.

For receiver and transmitter radiation measurements, the test antenna is connected to a measuring receiver, capable of being tuned to any frequency under investigation and of measuring accurately the relative levels of signals at its input. For receiver radiated sensitivity measurements the test antenna is connected to a signal generator.

A.1.3 Substitution antenna

When measuring in the frequency range up to 1 GHz the substitution antenna shall be a $\lambda/2$ dipole, resonant at the frequency under consideration, or a shortened dipole, calibrated to the $\lambda/2$ dipole. When measuring in the frequency range above 4 GHz a horn radiator shall be used. For measurements between 1 GHz and 4 GHz either a $\lambda/2$ dipole or a horn radiator may be used. The centre of this antenna shall coincide with the reference point of the test sample it has replaced. This reference point shall be the volume centre of the sample when its antenna is mounted inside the cabinet, or the point where an external antenna is connected to the cabinet.

The distance between the lower extremity of the dipole and the ground shall be at least 0,3 m.

The substitution antenna shall be connected to a calibrated signal generator when the site is used for spurious radiation measurements and transmitter effective radiated power measurements. The substitution antenna shall be connected to a calibrated measuring receiver when the site is used for the measurement of receiver sensitivity.

The signal generator and the receiver shall be operating at the frequencies under investigation and shall be connected to the antenna through suitable matching and balancing networks.

NOTE: The gain of a horn antenna is generally expressed relative to an isotropic radiator.

A.1.4 Optional additional indoor site

When the frequency of the signals being measured is greater than 80 MHz, use may be made of an indoor site. If this alternative site is used, this shall be recorded in the test report.

The measurement site may be a laboratory room with a minimum area of 6 m by 7 m and at least 2,7 m in height.

Apart from the measuring apparatus and the operator, the room shall be as free as possible from reflecting objects other than the walls, floor and ceiling.

The potential reflections from the wall behind the equipment under test are reduced by placing a barrier of absorbent material in front of it. The corner reflector around the test antenna is used to reduce the effect of reflections from the opposite wall and from the floor and ceiling in the case of horizontally polarized measurements. Similarly, the corner reflector reduces the effects of reflections from the side walls for vertically polarized measurements. For the lower part of the frequency range (below approximately 175 MHz) no corner reflector or absorbent barrier is needed. For practical reasons, the $\lambda/2$ antenna in figure A.2 may be replaced by an antenna of constant length, provided that this length is between $\lambda/4$ and λ at the frequency of measurement and the sensitivity of the measuring system is sufficient. In the same way the distance of $\lambda/2$ to the apex may be varied.

The test antenna, measuring receiver, substitution antenna and calibrated signal generator are used in a way similar to that of the general method.

To ensure that errors are not caused by the propagation path approaching the point at which phase cancellation between direct and the remaining reflected signals occurs, the substitution antenna shall be moved through a distance of $\pm 0,1$ m in the direction of the test antenna as well as in the two directions perpendicular to this first direction.

If these changes of distance cause a signal change of greater than 2 dB, the test sample should be re-sited until a change of less than 2 dB is obtained.

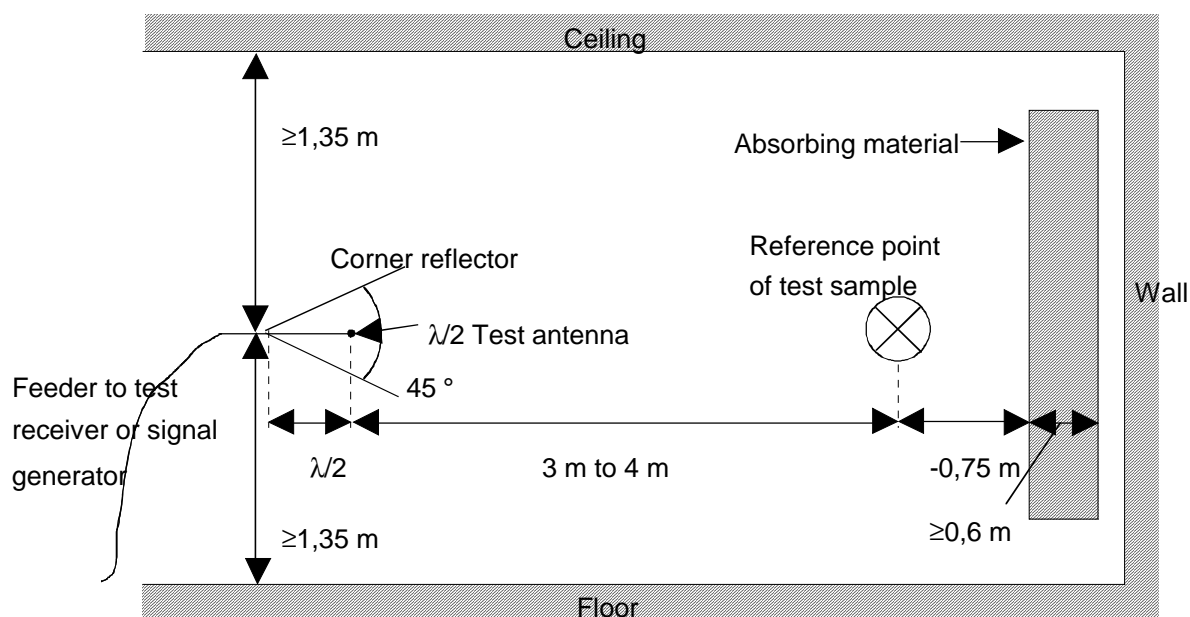

Figure A.2: Indoor site arrangement (shown for horizontal polarization)

A.2 Guidance on the use of radiation test sites

For measurements involving the use of radiated fields, use may be made of a test site in conformity with the requirements of clause A.1 of this annex. When using such a test site, the following conditions should be observed to ensure consistency of measuring results.

A.2.1 Measuring distance

Evidence indicates that the measuring distance is not critical and does not significantly affect the measuring results, provided that the distance is not less than $\lambda/2$ at the frequency of measurement, and the precautions described in this annex are observed. Measuring distances of 3 m, 5 m, 10 m and 30 m are in common use in European test laboratories.

A.2.2 Test antenna

Different types of test antenna may be used, since performing substitution measurements reduces the effect of the errors on the measuring results.

Height variation of the test antenna over a range of 1 m to 4 m is essential in order to find the point at which the radiation is a maximum.

Height variation of the test antenna may not be necessary at the lower frequencies below about 100 MHz.

A.2.3 Substitution antenna

Variations in the measuring results may occur with the use of different types of substitution antenna at the lower frequencies below about 80 MHz.

Where a shortened dipole antenna is used at these frequencies, details of the type of antenna used should be included with the results of the tests carried out on the site. Correction factors shall be taken into account when shortened dipole antennas are used.

A.2.4 Artificial antenna

The dimensions of the artificial antenna used during radiated measurements should be small in relation to the sample under test.

Where possible, a direct connection should be used between the artificial antenna and the test sample.

In cases where it is necessary to use a connecting cable, precautions should be taken to reduce the radiation from this cable by, for example, the use of ferrite cores or double screened cables.

A.2.5 Auxiliary cables

The position of auxiliary cables (power supply and microphone cables etc.) which are not adequately decoupled may cause variations in the measuring results. In order to get reproducible results, cables and wires of auxiliaries should be arranged vertically downwards (through a hole in the non conducting support).

A.2.6 Acoustic measuring arrangement

When carrying out measurements of the maximum usable sensitivity (radiated) of the receiver, the audio output shall be monitored by acoustically coupling the audio signal from the receiver loudspeaker/transducer to the test microphone. On the radiation test site all conducting materials shall be placed below the ground surface and the acoustic signal is conveyed from the receiver to the test microphone in a non-conducting acoustic pipe.

The acoustic pipe shall have an appropriate length. The acoustic pipe shall have an inner diameter of 6 mm and a wall thickness of 1,5 mm. A plastic funnel of a diameter corresponding to the receiver loudspeaker/transducer shall be attached to the receiver surface centred in front of the receiver loudspeaker/transducer. The plastic funnel shall be very soft at the attachment point to the receiver in order to avoid mechanical resonance. The narrow end of the plastic funnel shall be connected to the one end of the acoustic pipe and the test microphone to the other.

A.3 Further optional alternative indoor test site using an anechoic chamber

For radiation measurements when the frequency of the signals being measured is greater than 30 MHz, use may be made of an indoor site being a well-shielded anechoic chamber simulating free space environment. If such a chamber is used, this shall be recorded in the test report.

The test antenna, measuring receiver, substitution antenna and calibrated signal generator are used in a way similar to that of the general method, clause A.1. In the range between 30 MHz and 100 MHz some additional calibration may be necessary.

An example of a typical measurement site may be an electrically shielded anechoic chamber being 10 m long, 5 m broad and 5 m high.

Walls and ceiling should be coated with RF absorbers of 1 m height.

The base should be covered with absorbing material 1 m thick, and a wooden floor, able to carry test equipment and operators.

A measuring distance of 3 m to 5 m in the long middle axis of the chamber can be used for measurements up to 12,75 GHz.

The construction of the anechoic chamber is described in the following subclauses.

A.3.1 Example of the construction of a shielded anechoic chamber

Free-field measurements can be simulated in a shielded measuring chamber where the walls are coated with RF absorbers.

Figure A.3 shows the requirements for shielding loss and wall return loss of such a room.

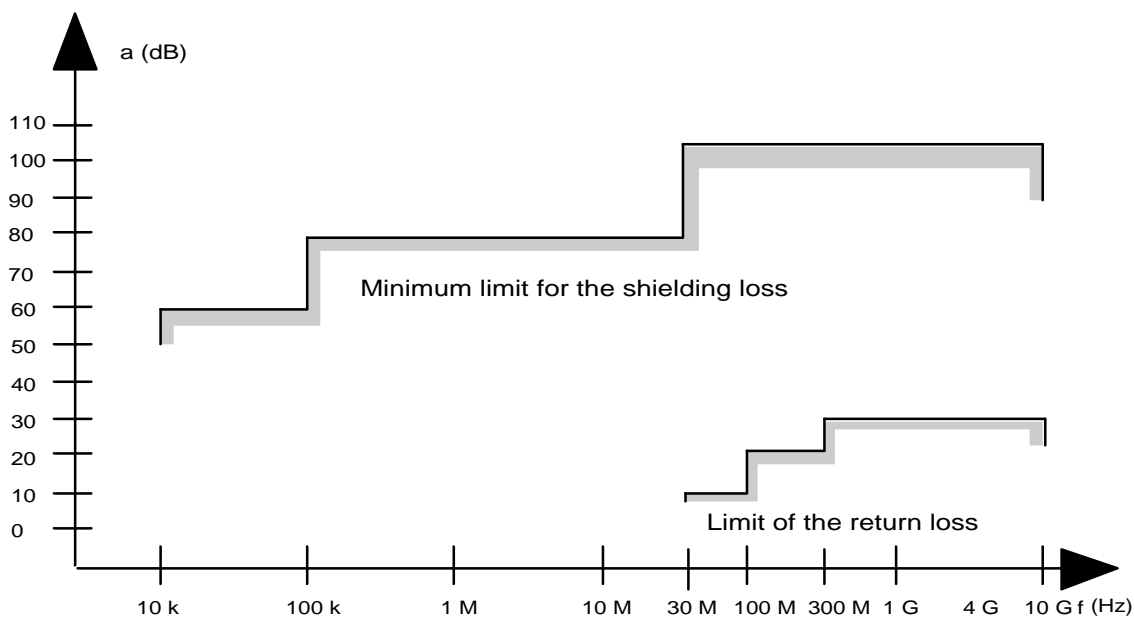

Figure A.3

As dimensions and characteristics of usual absorber materials are critical below 100 MHz (height of absorbers < 1 m, reflection attenuation < 20 dB) such a room is preferably suitable for measurements above 100 MHz.

Figure A.4 shows the construction of a shielded measuring chamber having a base area of 5 m by 10 m and a height of 5 m.

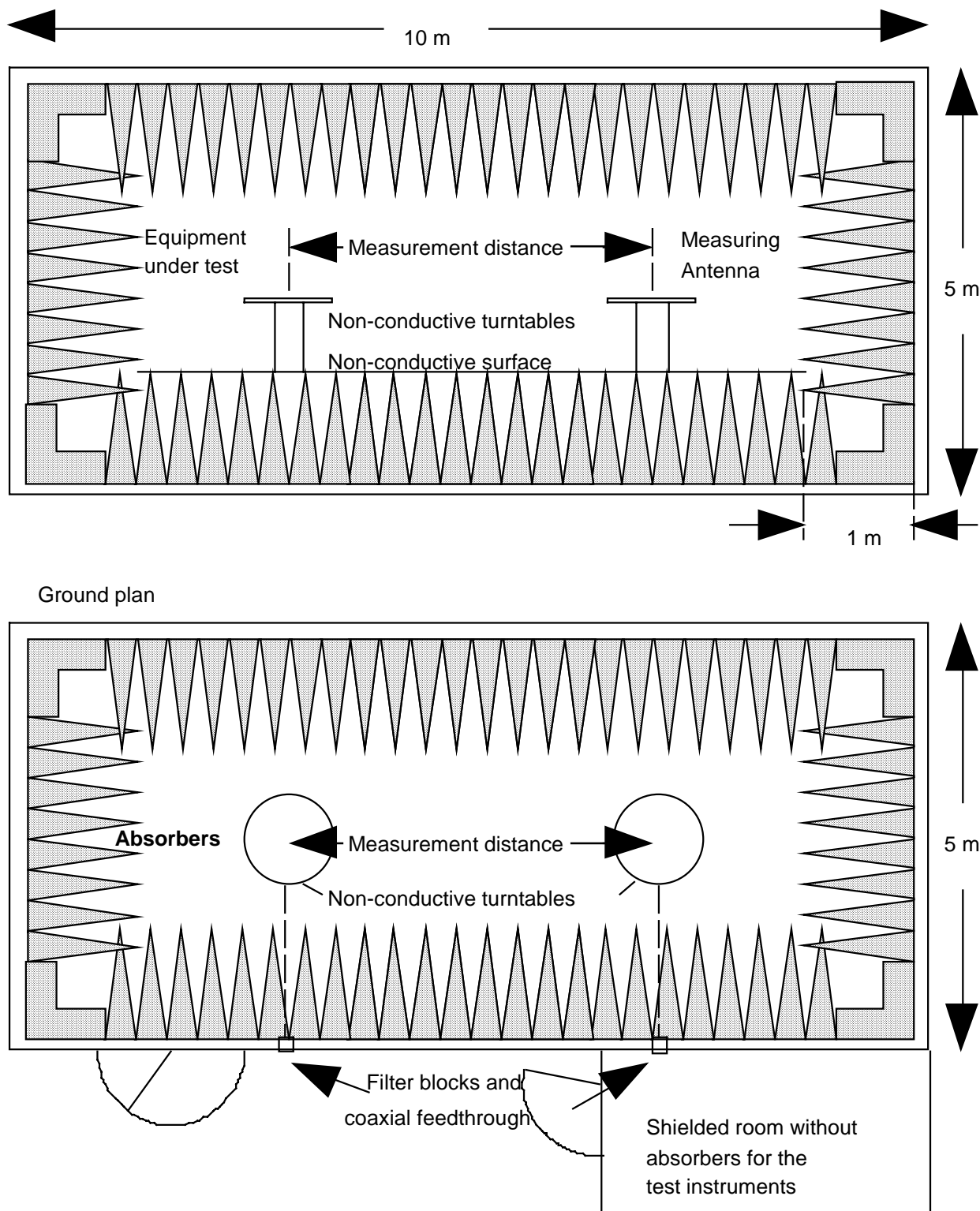

Figure A.4

Ceilings and walls are coated with pyramidal formed absorbers approximately 1 m high. The base is covered with absorbers which are able to carry and which forms a sort of floor.

The available internal dimensions of the room are 3 m x 8 m x 3 m, so that a measuring distance of maximum 5 m length in the middle axis of this room is available.

At 100 MHz the measuring distance can be extended up to a maximum of 2 lambda wavelength.

The floor absorbers reject floor reflections so that the antenna height need not be changed and floor reflection influences need not be considered.

All measuring results can therefore be checked with simple calculations and the measuring tolerances have the smallest possible values due to the simple measuring configuration.

For special measurements it can be necessary to re-introduce floor reflections. Taking away the floor absorbers would mean a removal of approximately 24 m³ absorber material. Therefore the floor absorbers are covered with metal plates of metallic nets instead.

A.3.2 Influence of parasitic reflections in anechoic chambers

For free-space propagation in the far field condition the correlation $E = E_0 (R_0/R)$ is valid for the dependence of the field strength E on the distance R , whereby E_0 is the reference field strength in the reference distance R_0 .

It is useful to use just this correlation for comparison measurements, as all constants are eliminated with the ratio and neither cable attenuation nor antenna mismatch or antenna dimensions are of importance.

Deviations from the ideal curve can be seen easily if the logarithm of the above equation is used, because the ideal correlation of field strength and distance can then be shown as a straight line and the deviations occurring in practice are clearly visible. This indirect method shows the disturbances due to reflections more readily and is far less problematical than the direct measurement of reflection attenuation.

With an anechoic chamber of the dimensions suggested in clause A.3 at low frequencies up to 100 MHz there are no far field conditions, and therefore reflections are stronger so that careful calibration is necessary.

In the medium frequency range from 100 MHz to 1 GHz the dependence of the field strength on the distance meets the expectations very well.

In the frequency range of 1 GHz to 12,75 GHz, because more reflections will occur, the dependence of the field strength on the distance will not correlate so closely.

A.3.3 Calibration of the shielded anechoic chamber

Careful calibration of the chamber shall be performed over the range 30 MHz to 12,75 GHz.

History

Document history		
V1.1.1	August 1999	Public Enquiry PE 9953: 1999-08-04 to 1999-12-03
V1.1.1	March 2000	Vote V 20000526: 2000-03-27 to 2000-05-26
V1.1.1	July 2000	Publication