

**Satellite Personal Communications Networks (S-PCN);
Mobile Earth Stations (MESs),
including handheld earth stations,
for S-PCN in the 1,5/1,6 GHz bands,
providing voice and/or data communications
under the Mobile Satellite Service (MSS)**



Reference

DEN/SES-00035

Keywords

S-PCN, mobile, satellite, service, MSS, earth station, MES, multimode, radio

ETSI

Postal address

F-06921 Sophia Antipolis Cedex - FRANCE

Office address650 Route des Lucioles - Sophia Antipolis
Valbonne - FRANCE
Tel.: +33 4 92 94 42 00 Fax: +33 4 93 65 47 16
Siret N° 348 623 562 00017 - NAF 742 C
Association à but non lucratif enregistrée à la
Sous-Préfecture de Grasse (06) N° 7803/88

Internetsecretariat@etsi.fr
Individual copies of this ETSI deliverable
can be downloaded from
<http://www.etsi.org>
If you find errors in the present document, send your
comment to: editor@etsi.fr

Important notice

This ETSI deliverable may be made available in more than one electronic version or in print. In any case of existing or perceived difference in contents between such versions, the reference version is the Portable Document Format (PDF). In case of dispute, the reference shall be the printing on ETSI printers of the PDF version kept on a specific network drive within ETSI Secretariat.

Copyright Notification

No part may be reproduced except as authorized by written permission.
The copyright and the foregoing restriction extend to reproduction in all media.

© European Telecommunications Standards Institute 1999.
All rights reserved.

Contents

Intellectual Property Rights	6
Foreword.....	6
1 Scope	7
2 References	7
3 Definitions and abbreviations	8
3.1 Definitions	8
3.2 Abbreviations	9
4 General	10
4.1 Presentation of equipment for testing purposes	10
4.2 Description of equipment	10
4.3 Host-connected equipment	11
5 Unwanted emissions outside the band 1 626,5 MHz to 1 660,5 MHz (carrier-on)	11
5.1 Purpose	11
5.2 Conformance requirements	12
5.3 Method of test.....	12
5.3.1 Peak measurement	13
5.3.2 Average measurement	13
5.4 Test requirements	14
6 Unwanted emissions within the bands 1 626,5 MHz to 1 660,5 MHz, 1 624,5 MHz to 1 626,5 MHz and 1 660,5 MHz to 1 662,5 MHz (carrier-on)	14
6.1 Purpose	14
6.2 Conformance requirements	14
6.3 Method of test.....	15
6.3.1 Measurement method.....	16
6.4 Test requirements	16
7 Unwanted emissions in carrier-off state.....	16
7.1 Purpose	16
7.2 Conformance requirements	17
7.3 Method of test.....	17
7.3.1 Measurement method.....	17
7.4 Test requirements	18
8 MES Control and Monitoring Functions (CMF)	18
8.1 Special test equipment	18
8.2 Self-monitoring functions	18
8.2.1 Processor monitoring	18
8.2.1.1 Purpose.....	18
8.2.1.2 Conformance requirements	18
8.2.1.3 Method of test	18
8.2.2 Transmit frequency generation sub-system monitoring	19
8.2.2.1 Purpose.....	19
8.2.2.2 Conformance requirements	19
8.2.2.3 Method of test	19
8.3 Network control authorization and reception	19
8.3.1 Network control authorization	19
8.3.1.1 Purpose.....	19
8.3.1.2 Conformance requirements	19
8.3.1.3 Method of test	19
8.3.1.4 Test procedure.....	20
8.3.1.5 Test requirement.....	20
8.3.2 Network Control Reception	20
8.3.2.1 Transmission disable/enable	20

8.3.2.1.1	Purpose	20
8.3.2.1.2	Conformance requirements	20
8.3.2.1.3	Method of test	21
8.3.2.1.4	Test procedure	21
8.3.2.1.5	Test requirement	21
8.3.2.2	Transmit frequency control	22
8.3.2.2.1	Purpose	22
8.3.2.2.2	Conformance requirements	22
8.3.2.2.3	Method of test	22
8.3.2.2.4	Test procedure	22
8.3.2.2.5	Test requirement	22
8.4	Fellow radio stations in a dual-mode or multi-mode terminal	23
8.4.1	Purpose	23
8.4.2	Conformance requirements	23
8.4.3	Method of test	23
8.4.4	Test procedure	23
8.4.5	Test requirements	23
9	Equipment identity	23
9.1	Purpose	23
9.2	Conformance requirements	23
9.3	Method of test	23
9.4	Test procedure	24
9.5	Test requirements	24
10	Protection of the radio astronomy service operation in the band 1 660 MHz to 1 660,5 MHz	24
10.1	Purpose	24
10.2	Conformance requirements	24
10.3	Method of test	24
10.4	Test procedure	24
10.5	Test requirements	24
Annex A (normative):	General test requirements.....	25
A.1	MES test modes	25
A.2	Special Test Equipment	25
A.2.1	STE description	25
A.2.2	Use of STE for control and monitoring functions tests	26
A.2.3	Test modulating signal	26
A.3	Laboratory Test Equipment (LTE)	27
A.4	Methods of test for MES RF emissions	27
A.5	Interpretation of the measurement results	27
A.6	Test report	28
Annex B (normative):	Environmental conditions and host connected equipment	29
B.1	General	29
B.2	Environmental requirements	29
B.2.1	Temperature	29
B.2.2	Voltage	29
B.2.3	Vibration	29
B.3	Environmental test conditions	29
B.3.1	Specification of the environmental test conditions	29
B.3.2	Tests under extreme voltage conditions	30
B.4	Testing of host-connected equipment and plug-in modules	30
B.4.1	Alternative A: combined equipment	30
B.4.2	Alternative B: use of a test jig	30

Annex C (normative):	Procedures for measurement of radiated emissions	31
C.1	General	31
C.1.1	Test site	31
C.1.2	Test set up for radiated emissions of the MES	31
C.1.3	Reference position of the MES.....	32
C.2	Measurement procedure for radiated emissions (peak)	32
C.2.1	Measurement procedure for peak radiated emissions of the MES.....	32
C.2.2	Measurement procedure for peak radiated emissions of the cabinet	34
C.3	Measurement procedure for radiated emissions (average)	35
C.3.1	Measurement procedure for average radiated emissions of the MES.....	35
C.3.2	Measurement procedure for average radiated emissions of the cabinet.....	36
Annex D (normative):	Procedures for measurement of conducted emissions	37
D.1	General	37
D.1.1	Test site	37
D.1.2	Test set-up	37
D.2	Measurement procedure for conducted emissions (peak).....	38
D.3	Measurement procedure for conducted emissions (average).....	38
Annex E (informative):	Explanation of nominated bandwidth	39
E.1	Introduction	39
E.2	Interpretation of Parameters [B_n, f_c, a, b]	39
E.3	Choice of nominated bandwidth	39
E.4	Maximum value for nominated bandwidth	41
	Bibliography	43
	History	44

Intellectual Property Rights

IPRs essential or potentially essential to the present document may have been declared to ETSI. The information pertaining to these essential IPRs, if any, is publicly available for **ETSI members and non-members**, and can be found in SR 000 314: *"Intellectual Property Rights (IPRs); Essential, or potentially Essential, IPRs notified to ETSI in respect of ETSI standards"*, which is available from the ETSI Secretariat. Latest updates are available on the ETSI Web server (<http://www.etsi.org/ipr>).

Pursuant to the ETSI IPR Policy, no investigation, including IPR searches, has been carried out by ETSI. No guarantee can be given as to the existence of other IPRs not referenced in SR 000 314 (or the updates on the ETSI Web server) which are, or may be, or may become, essential to the present document.

Foreword

This European Standard (Telecommunications series) has been produced by ETSI Technical Committee Satellite Earth Stations and Systems (SES), and is now submitted for the Public Enquiry phase of the ETSI standards Two-step Approval Procedure.

Proposed national transposition dates	
Date of latest announcement of this EN (doa):	3 months after ETSI publication
Date of latest publication of new National Standard or endorsement of this EN (dop/e):	6 months after doa
Date of withdrawal of any conflicting National Standard (dow):	6 months after doa

1 Scope

The present document applies to S-PCN MES with an EIRP less than or equal to 15 dBW.

The present document sets out the minimum performance requirements and technical characteristics of Mobile Earth Stations (MES) with both transmit and receive capabilities for operation in a Satellite Personal Communication Network (S-PCN) in one or more of the Mobile Satellite Service (MSS) frequency bands given in table 1.

Table 1: Mobile Satellite Service (MSS) frequency bands

	MSS frequency bands
MESs transmit	1 626,5 MHz to 1 660,5 MHz
MESs receive	1 525 MHz to 1 559 MHz

An S-PCN MES may be handheld, portable, vehicle-mounted, host connected, semi-fixed or fixed equipment, or may be an element in a multi-mode terminal; it may consist of a number of modules with associated connections and user interface, or may be a self contained single unit.

If the MES is an element in a multi-mode terminal, unless otherwise stated in the present document, its requirements apply only to the S-PCN MES element of the terminal operating in one or more of the MSS frequency bands given in table 1.

The requirements of the present document are divided in two major categories:

- **unwanted emission limits:** to protect other radio services from harmful interference generated by the MES in normal use;
- **MES Control and Monitoring Functions (CMF):** to protect other radio services from unwanted transmissions from the MES. The CMF in each MES is capable of answering to commands from the Network Control Facilities (NCF) for its S-PCN.

NOTE: The requirements for NCF for S-PCN are contained in EN 301 682 [2].

2 References

The following documents contain provisions which, through reference in this text, constitute provisions of the present document.

- References are either specific (identified by date of publication, edition number, version number, etc.) or non-specific.
- For a specific reference, subsequent revisions do not apply.
- For a non-specific reference, the latest version applies.
- A non-specific reference to an ETS shall also be taken to refer to later versions published as an EN with the same number.

- [1] ITU-T Recommendation O.153 (1988): "Characteristics of distortion and error-rate measuring apparatus for data transmission".
- [2] EN 301 682: "Satellite Personal Communications Networks (S-PCN); Network Control Facilities (NCF) for Mobile Earth Stations (MESs), including handheld earth stations, for S-PCN in the 1,5/1,6 GHz bands, providing voice and/or data communications under the Mobile Satellite Service (MSS)".
- [3] IEC 60068-2-1: "Environmental testing - Part 2: Tests. Tests A: Cold".
- [4] IEC 60068-2-2: "Environmental testing - Part 2: Tests. Tests B: Dry heat".

- [5] IEC 60068-2-36: "Environmental testing. Part 2: Tests. Test Fdb: Random vibration wide band - Reproducibility Medium".

3 Definitions and abbreviations

3.1 Definitions

For the purposes of the present document, the following terms and definitions apply:

applicant: party seeking an approval, or to place an S-PCN MES on the market, i.e. the manufacturer of the equipment, or his authorized representative, or an equipment supplier to the market

carrier-on time (initial bursts): carrier-on time is the period when an MES is transmitting a signal. For MESs that transmit in a non-continuous mode, the carrier-on time only includes the times when the MES is transmitting a signal

carrier-on state (allocated a channel): MES is in this state when it is transmitting a signal in a continuous or non-continuous mode

carrier-off state (idle mode): MES is in this state when it is powered-on but not transmitting a signal, i.e. not in carrier-on state

conducted measurement: measurement of emissions from an antenna port of the MES made by direct wired connection to the port

Equivalent Isotropically Radiated Power (EIRP): product of transmitter power and maximum antenna gain, equivalent to an isotropic source radiating uniformly in all directions

fellow radio station: one of the (other) modes of a multi-mode MES

handheld: indicates an MES which is self-contained and is small enough and light enough to be carried and used during a call with one hand

host-connected: indicates an MES for which connection to or integration with host equipment is necessary to offer functionality

host equipment: any equipment which has a complete user functionality when not connected to the MES, and to which the MES provides additional functionality, and to which connection is necessary for the MES to offer functionality

Installable Equipment (IE), Internally Mounted Equipment (IME) and Externally Mounted Equipment (EME): Installable Equipment (IE) is an equipment which is intended to be installed in a vehicle. An IE may consist of one or several interconnected modules. The IE is composed of modules intended to be externally mounted as declared by the applicant, and defined as Externally Mounted Equipment (EME) and the remaining module(s) as Internally Mounted Equipment (IME)

Laboratory Test Equipment (LTE): logical grouping that contains the standard test equipment provided by a test laboratory

MSS band: continuous range of frequencies allocated by the ITU to the MSS

multi-mode: indicates equipment that accommodates radio stations of different radio networks

narrow-band system: narrow band system is one in which the nominal carrier frequency spacing for MESs in the earth-to-space direction is less than 300 kHz

network control channel: channel by which an MES receives general control information from the NCF of its S-PCN

NCF control message: message, normally originating from a network, to a specified terminal or set of terminals of the network which indicates to the terminal or set of terminals that it/they should carry out some specific action or should enter or maintain some specific state. For test purposes NCF control messages may originate from Special Test Equipment (STE)

nominated bandwidth (B_n): B_n of the Mobile Earth Station (MES) radio frequency transmission is wide enough to encompass all spectral elements of the transmission which have a level greater than the specified levels of unwanted emissions. The B_n is defined relative to the MES actual carrier frequency f_c .

B_n is the width of the frequency interval ($f_c - a$, $f_c + b$), where a and b, which shall be specified by the applicant, may vary with f_c .

The frequency interval ($f_c - a$, $f_c + b$) shall not encompass more than either:

- 1) when $a = b$, 4 nominal carrier frequencies for narrow-band systems;
- 2) when $a \neq b$, 1 nominal carrier frequency for narrow-band systems; or
- 3) 1 nominal carrier frequency for wide-band systems.

The frequency interval ($f_c - a$, $f_c + b$) shall be within the operational band of the MES

operational band: sub-portion of the band 1 626,5 MHz to 1 660,5 MHz which has been assigned in the earth-to-space direction to the MSS network, within which the MES is operating

Portable Equipment (PE): Portable Equipment (PE) is generally intended to be self-contained, free standing and portable. A PE would normally consist of a single module, but may consist of several interconnected modules

radiated measurement: measurement of an actual radiated field

Special Test Equipment (STE): equipment which allows a test laboratory to control the MES so that the tests required by the present document can be performed

test laboratory: laboratory authorized by an accreditation body, which performs conformance testing in accordance with the SES and TTE directives

test load: test load is a substantially non-reactive, non-radiating power attenuator which is capable of safely dissipating the power from the transmitter(s)

transmission format: physical characteristics of the signal that is transmitted by an MES. An MES may use more than one transmission format within a single S-PCN

unwanted emissions: unwanted emissions are those falling outside the nominated bandwidth in the carrier-on state and those generated in the carrier-off state

wide-band system: wide-band system is one in which the nominal carrier frequency spacing for MESs in the earth-to-space direction is equal or greater than 300 kHz

3.2 Abbreviations

For the purposes of the present document, the following abbreviations apply:

B _n	nominated Bandwidth
CCITT	Comité Consultatif International Télégraphique et Téléphonique (now ITU-T)
CDMA	Code Division Multiple Access
CMF	Control and Monitoring Functions
dBW	decibels relative to 1 Watt
EIRP	Equivalent Isotropically Radiated Power
EMC	Electro-Magnetic Compatibility
EME	Externally Mounted Equipment
IE	Installable Equipment
IEC	International Electrotechnical Commission/Committee
IME	Internally Mounted Equipment
ITU	International Telecommunications Union
LTE	Laboratory Test Equipment

MES	Mobile Earth Station
MSS	Mobile Satellite Service
MIC	MES Identification Code (unique within its S-PCN)
NCF	Network Control Facility
PE	Portable Equipment
RF	Radio Frequency
SES	Satellite Earth Stations and Systems or, in the case of the SES Directive, Satellite Earth Station
S-PCN	Satellite Personal Communications Network
STE	Special Test Equipment
TDMA	Time Division Multiple Access
TTE	Telecommunications Terminal Equipment

4 General

4.1 Presentation of equipment for testing purposes

The applicant may provide to a test laboratory one or more preliminary or production models of the MES equipment, as appropriate, for testing for conformance against the technical requirements of the present document.

If the MES is intended for use with an active antenna, this shall be provided as part of the MES.

If a statement of conformance with the present document is given by the test laboratory on the basis of tests on a preliminary model, then the statement of conformance shall apply to corresponding production models only if they are identical in all technical respects with the preliminary model tested.

4.2 Description of equipment

The applicant shall provide to the test laboratory a statement which contains all of the information related to the MES and its testing environment which will enable the test laboratory to run an appropriate test suite against the MES.

This shall include:

- Self contained or host-connected;
- Single-mode or multi-mode;
- Antenna:
 - active or;
 - passive, with an antenna port available or;
 - passive, no antenna port available;
- The method by which the equipment can be switched into its test modes;
- the fault conditions which cause transmission shut-down;
- the nominal, the lower extreme and the higher extreme operational voltages;

- In an information leaflet, for each S-PCN for which the MES is designed to operate:
 - (a) the name of the S-PCN;
 - (b) the maximum value of nominated bandwidth for that S-PCN;
 - (c) the a and b values of the nominated bandwidth for each nominal carrier frequency of the MES;
 - (d) the operating frequency range(s) of the MES;
 - (e) the frequency sub-bands and operating conditions for which the different EIRP density limits apply;
 - (f) the transmission formats for which the different EIRP density limits apply and the maximum gross data rate at which the MES is designed to operate for each of those formats;
 - (g) the agreement of the network operator to the above information.

NOTE 1: In the case of a multi-mode MES, the other modes of operation shall be stated.

NOTE 2: If the MES has an active antenna, the antenna is regarded as an integral part of the MES and the antenna port if available shall not be used for testing.

NOTE 3: If the MES is intended for use with a passive antenna, the maximum gain of any antenna intended to be used with the equipment is to be stated.

NOTE 4: If conducted emissions measurements are to be performed, at the choice of the applicant, the maximum antenna gain at the frequency of particular measured spurious emissions may be stated.

NOTE 5: If Special Test Equipment (STE) is required see clause A.2.

NOTE 6: Transmission formats include all relevant differences in the format of the transmitted data e.g. the different modulations schemes and/or burst sizes that are used within the relevant S-PCN.

4.3 Host-connected equipment

For testing of equipment for which connection to, or integration with, host equipment is required to offer functionality, the applicant shall supply a statement indicating which of the test configurations detailed in clause B.4 shall be used.

5 Unwanted emissions outside the band 1 626,5 MHz to 1 660,5 MHz (carrier-on)

5.1 Purpose

Protection of other radio services operating outside the band 1 626,5 MHz to 1 660,5 MHz from emissions caused by S-PCN MESs operating within the band 1 626,5 MHz to 1 660,5 MHz.

5.2 Conformance requirements

The maximum EIRP density of the unwanted emissions from the MES outside the band 1 626,5 MHz to 1 660,5 MHz shall not exceed the limits in table 2.

In table 2, whenever a change of limit between adjacent frequency bands occurs, the lower of the two limits shall apply at the transition frequency.

Table 2: Unwanted emissions outside the band 1 626,5 MHz to 1 660,5 MHz

Frequency (MHz)	Carrier - on		
	EIRP (dBW)	Measurement bandwidth	Measurement method
0,1 to 30	-66	10 kHz	Peak Hold
30 to 1 000	-66	100 kHz	Peak Hold
1 000 to 1 559	-60	3 MHz	Average
1 559 to 1 605,0	-70	1 MHz (note3)	Average (note2)
1 605,0 to 1 612,5	-70 to - 58,5 (note4)	1 MHz (note3)	Average
1 612,5 to 1 616,5	-60	300 kHz	Average
1 616,5 to 1 621,5	-60	100 kHz	Average
1 621,5 to 1 624,5	-60	30 kHz	Average
1 624,5 to 1 626,5	The levels in table 3b shall apply from 1 624,5 MHz to 1 626,5 MHz		
1 626,5 to 1 660,5	NOT APPLICABLE	NOT APPLICABLE	NOT APPLICABLE
1 660,5 to 1 662,5	The levels in table 3a shall apply from 1 660,5 MHz to 1 662,5 MHz		
1 662,5 to 1 665,5	-60	30 kHz	Average
1 665,5 to 1 670,5	-60	100 kHz	Average
1 670,5 to 1 680,5	-60	300 kHz	Average
1 680,5 to 1 690,5	-60	1 MHz	Average
1 690,5 to 2 250	-60	3 MHz	Average
2 250 to 12 750	-60	3 MHz	Peak Hold (note1)
NOTE 1: In each of the bands 3 253,0 MHz to 3 321,0 MHz; 4 879,5 MHz to 4 981,5 MHz and 6 506,0 MHz to 6 642,0 MHz the maximum EIRP in one, and only one, 100 kHz measurement bandwidth shall not exceed -65 dBW. An average measurement method shall be used. Elsewhere in this band the power limit in table 2 shall be applied.			
NOTE 2: The average measurement method defined in subclause 5.3.2. shall apply except that a measurement time of 20 ms shall be used in the sub-band 1 573,42 to 1 580,42 MHz.			
NOTE 3: Measurement bandwidths less than 1 MHz are allowable provided the power in the narrower bandwidth is integrated over 1 MHz.			
NOTE 4: Linearly interpolated in dBW vs. Frequency.			

The conformance requirements apply for the full range of environmental conditions corresponding to the type of equipment as specified in clause B.2.

5.3 Method of test

This test shall be carried out for the minimum and for the maximum MES transmit frequencies for which the MES is designed to operate, as specified by the applicant.

If the MES supports multiple transmission formats, each of the relevant transmission formats shall be tested at each frequency.

The transmit frequencies and the transmission formats used for the test shall be entered in the test report.

The environmental test conditions are given in clause B.3.

For each test, the MES shall be set to transmit (carrier-on) on one of the specified transmitting frequencies to be tested and in one of the specified transmission formats to be tested and shall be set to transmit at its maximum power for that transmit frequency and transmission format, by means of the STE or by another test facility provided by the applicant.

If there is a handover function in the MES (to allow change of frequency channel during a call), this function shall be disabled.

The transmitted carrier shall be modulated by a test signal as specified in subclause A.2.3.

In the test equipment, the spectrum analyser noise floor shall be at least 6 dB below the appropriate limits given in table 2.

The measurements are performed with the radiated or with the conducted method according to the cases defined in clause A.4.

For measurements of radiated unwanted emissions, annex C applies.

For measurements of conducted unwanted emissions, annex D applies.

5.3.1 Peak measurement

In the case of peak measurement, the spectrum analyser shall be set in sweep mode and shall be operated under the following conditions:

- frequency sweep: as required for frequency range to be assessed;
- resolution bandwidth: measurement bandwidth specified in table 2;
- display bandwidth: at least three times the measurement bandwidth;
- averaging: no;
- peak hold: yes.

The sweep time shall be the shortest possible time consistent with proper calibration and ease of operation.

The spectrum analyser shall be stepped over the frequency ranges specified in table 2 for peak measurement.

5.3.2 Average measurement

In the case of average measurement, the spectrum analyser shall be set in sweep mode and shall be operated under the following conditions:

- frequency sweep: as required for frequency range to be assessed;
- resolution bandwidth: measurement bandwidth specified in table 2;
- display bandwidth: equal to the measurement bandwidth;
- averaging: yes;
- peak hold: no.

The measurement time shall be such that the difference of the measured levels, averaged over subsequent measurement samples, is less than 1 dB.

For a MES operating in a non-continuous carrier mode, the measurement shall be performed over the active part of the transmitted bursts. The total sample time used for measurement shall be not less than 40 % of the duration of the active part of the transmitted burst. The measurement shall be made over the random part of the burst, excluding any preambles or synchronization sequences.

The spectrum analyser shall be stepped over the frequency ranges specified in table 2 for average measurement.

5.4 Test requirements

For measurements of radiated unwanted emissions of the MES, the measured values shall in no case exceed the limits given in table 2.

For measurements of conducted unwanted emissions of the MES, the measured values plus the maximum antenna gain shall in no case exceed the limits given in table 2.

6 Unwanted emissions within the bands 1 626,5 MHz to 1 660,5 MHz, 1 624,5 MHz to 1 626,5 MHz and 1 660,5 MHz to 1 662,5 MHz (carrier-on)

6.1 Purpose

Protection of radio services and systems operating within the frequency bands 1 624,5 MHz to 1 626,5 MHz, 1 626,5 MHz to 1 660,5 MHz and 1 660,5 MHz to 1 662,5 MHz from unwanted emissions caused by S-PCN MESs operating in the band 1 626,5 MHz to 1 660,5 MHz.

6.2 Conformance requirements

The maximum EIRP spectral density of the unwanted emissions from the MES within the 1 624,5 MHz to 1 662,5 MHz shall not exceed the limits in tables 3a and 3b.

When conflicts between multiple requirements exist, the more stringent requirement applies.

In the table 3a, whenever a change of limit between adjacent frequency bands occurs, the lower of the two limits shall apply at the transition frequency.

Table 3a: Maximum unwanted emissions in the bands 1 626,5 MHz to 1 660,5 MHz and 1 660,5 MHz to 1 662,5 MHz caused by S-PCN MESs operating in the band 1 626,5 MHz to 1 660,5 MHz

Frequency offset (kHz) (note1)	Carrier - on		
	EIRP (dBW) (note2)	Measurement bandwidth (kHz)	Measurement method
0 to 25	0 to -15	3	Average
25 to 125	-15 to -50	3	Average
125 to 425	-50	3	Average
425 to 1 500	-50 to -65	3	Average
1 500 to 36 000	-55	30	Average

NOTE 1: Frequency offset is determined from edge of nominated bandwidth.
NOTE 2: Linearly interpolated in dBW vs. Frequency offset.

Table 3b: Maximum unwanted emissions in the bands 1 624,5 MHz to 1 626,5 MHz caused by S-PCN MESs operating in the band 1 626,5 MHz to 1 660,5 MHz

Frequency (MHz)	Carrier - on		
	EIRP (dBW)	Measurement bandwidth (kHz)	Measurement method
1 624,5 – 1 625,0	-65	3	Average
1 625,0 to 1 625,8	-65 to -50 (note1)	3	Average
1 625,8 – 1 626,5	-50	3	Average

NOTE: Linearly interpolated in dBW vs. Frequency.

For systems employing CDMA, the EIRP limits in tables 3a and 3b above shall be decreased by $10 \log(N)$ dB, where N is the maximum number of MESs in the receive beam of the satellite to which these MESs are communicating and which are expected to transmit simultaneously in the same frequency band within that same beam. This number shall be declared by the manufacturer.

NOTE: N = 1 in a TDMA system.

The conformance requirements apply for the full range of environmental conditions corresponding to the type of equipment as specified in clause B.2.

6.3 Method of test

This test shall be carried out for the minimum and for the maximum MES transmit frequency for which the MES is designed to operate, as specified by the applicant.

If the MES supports multiple transmission formats, each of the relevant transmission formats shall be tested at each frequency.

The transmit frequencies and the transmission formats used for the test shall be entered in the test report.

The environmental test conditions are given in clause B.3.

For each test, the MES shall be set to transmit (carrier-on) on one of the specified transmitting frequencies to be tested and in one of the specified transmission formats to be tested and shall be set to transmit at its maximum power for that transmit frequency and transmission format, by means of the STE or by another test facility provided by the applicant.

If there is a handover function in the MES (to allow change of frequency channel during a call), this function shall be disabled.

The transmitted carrier shall be modulated by a test signal at maximum rate as specified in subclause A.2.3.

In the test equipment, the spectrum analyser noise floor shall be at least 6 dB below the appropriate limits given in tables 3a and 3b.

The measurements are performed with the radiated or with the conducted method according to the cases defined in clause A.4.

For measurements of radiated unwanted emissions, annex C applies.

For measurements of conducted unwanted emissions, annex D applies.

6.3.1 Measurement method

The spectrum analyser shall be set in sweep mode and shall be operated under the following conditions:

frequency sweep:	as required for frequency range to be assessed;
resolution bandwidth:	measurement bandwidth specified in tables 3a and 3b;
display bandwidth:	equal to the measurement bandwidth;
averaging:	yes;
peak hold:	no.

The measurement time should be such that the difference of the measured levels, averaged over subsequent measurement samples, is less than 1 dB.

For a MES operating in a non-continuous carrier mode, the measurement shall be performed over the active part of the transmitted bursts. The total sample time used for measurement shall be not less than 40 % of the duration of the active part of the transmitted burst. The measurement shall be made over the random part of the burst, excluding any preambles or synchronization sequences.

For each of the transmit frequencies to be used for the test, measurements shall be made over the frequency ranges from 1 624,5 MHz to $f_c - a$ and from $f_c + b$ to 1 662,5 MHz, $f_c - a$ being the lower boundary frequency of the nominated bandwidth for the transmit frequency being tested, and $f_c + b$ being the upper boundary frequency of the nominated bandwidth for the transmit frequency being tested.

6.4 Test requirements

For measurements of radiated unwanted emissions of the MES, the measured values shall in no case exceed the limits given in tables 3a and 3b over the frequency range 1 624,5 MHz to 1 662,5 MHz.

For measurements of conducted unwanted emissions, the measured values plus the maximum antenna gain, shall in no case exceed the limits given in tables 3a and 3b over the frequency range 1 624,5 MHz to 1 662,5 MHz.

7 Unwanted emissions in carrier-off state

7.1 Purpose

Protection of other radio services and systems from unwanted emissions caused by MESs in the carrier-off state.

7.2 Conformance requirements

The maximum EIRP of the unwanted emissions from the MESs in the carrier-off state shall not exceed the limits in table 4.

In table 4, whenever a change of limit between adjacent frequency bands occurs, the lower of the two limits shall apply at the transition frequency.

Table 4: Maximum EIRP of the unwanted emissions in the carrier-off state

Frequency (MHz)	EIRP (dBW)	Measurement bandwidth	Measurement method
0,1 to 30	-87	10 kHz	peak hold
30 to 1 000	-87	100 kHz	peak hold
1 000 to 1 525	-77	100 kHz	peak hold
1 525 to 1 559	-97 (note3)	100 kHz	average
1 559 to 1 610	-70	1 MHz (note1)	Average (note2)
1 610 to 12 750	-77	100 kHz	peak hold
NOTE 1: Measurement bandwidths less than 1 MHz are allowable provided the power in the narrower bandwidth is integrated over 1 MHz.			
NOTE 2: The average measurement method defined in subclause 5.3.2. shall apply except that a measurement time of 20 ms shall be used in the sub-band 1 573,42 MHz to 1 580,42 MHz.			
NOTE 3: If MES antenna gain is higher than 8dBi, the unwanted emission limit in the band 1 525 MHz to 1 559 MHz shall be considered to be -90 dBW in 100 kHz.			

The conformance requirements apply for the full range of environmental conditions corresponding to the type of equipment as specified in clause B.2.

7.3 Method of test

The MES shall be switched-on and set in a non-transmitting (carrier-off) mode.

If there is a periodic automatic transmission of bursts (e.g. for location updating), the STE shall provide a means to inhibit it, or to trigger the measurement in order to analyse only the non-transmitting periods.

The environmental test conditions are given in clause B.3.

In the test equipment, the spectrum analyser noise floor shall be at least 6 dB below the appropriate limits given in table 4.

The measurements are performed with the radiated or with the conducted method according to the cases defined in clause A.5.

For measurements of radiated unwanted emissions, annex C applies.

For measurements of conducted unwanted emissions, annex D applies.

7.3.1 Measurement method

The spectrum analyser shall be set in sweep mode and shall be operated under the following conditions:

- frequency sweep: as required for frequency range to be assessed;
- resolution bandwidth: measurement bandwidth specified in table 4;
- display bandwidth: at least 3 times the measurement bandwidth;
- averaging: no;
- peak hold: yes.

The sweep time shall be the shortest possible time consistent with proper calibration and ease of operation.

The spectrum analyser shall be stepped over the frequency ranges specified.

7.4 Test requirements

For measurements of radiated unwanted emissions of the MES, the measured values shall in no case exceed the limits given in table 4.

For measurements of conducted unwanted emissions of the MES, the measured values plus the maximum antenna gain shall in no case exceed the limits given in table 4.

8 MES Control and Monitoring Functions (CMF)

8.1 Special test equipment

Many of the tests in this clause require that the MES be situated in an environment where receipt of the appropriate network control channel(s) and of NCF commands is controlled by the test laboratory. This will require the provision by the applicant of Special Test Equipment (see clause A.2). This STE shall provide the means to generate and to communicate to the MES, either radiated via its antenna or conducted via direct connection to its antenna port, the appropriate network control channel(s) and the required NCF commands, under the control of the test laboratory. The STE shall also provide means for the test laboratory to interface its test equipment with the MES for the purpose of monitoring the MES responses.

8.2 Self-monitoring functions

8.2.1 Processor monitoring

8.2.1.1 Purpose

Protection of radio services and systems from uncontrolled RF transmissions from the MES.

8.2.1.2 Conformance requirements

The MES shall incorporate a processor monitoring function for each of its processors involved in the manipulation of traffic and in control and monitoring functions.

The processor monitoring function shall detect failure of the processor hardware and software.

Not later than 1 s after any detectable fault condition occurs, the transmissions shall be suppressed (carrier-off) until the processor monitoring function has determined that all fault conditions have been cleared.

The fault conditions which cause transmission shutdown shall be specified by the applicant and declared by the applicant.

The conformance requirements apply for the environmental conditions as specified in clause B.2.

8.2.1.3 Method of test

As it is considered impracticable to artificially induce processor faults in an MES, no test is given for the processor monitoring function.

8.2.2 Transmit frequency generation sub-system monitoring

8.2.2.1 Purpose

Protection of radio services and systems from uncontrolled RF transmissions from the MES.

8.2.2.2 Conformance requirements

The MES shall incorporate a transmit frequency generation sub-system monitoring function.

Not later than 5 s after any detectable failure of the transmit frequency generation sub-system occurs, the transmissions shall be suppressed (carrier-off) until the transmit frequency generation sub-system monitoring function has determined that all fault conditions have been cleared.

The fault conditions which cause transmission shutdown shall be specified by the applicant and declared by the applicant.

The conformance requirements apply for the environmental conditions as specified in clause B.2.

8.2.2.3 Method of test

As it is considered impracticable to artificially induce transmit frequency generation sub-system faults in an MES, no test is given for the transmit frequency generation sub-system monitoring function.

8.3 Network control authorization and reception

8.3.1 Network control authorization

8.3.1.1 Purpose

Protection of radio services and systems from uncontrolled RF transmissions from the MES.

8.3.1.2 Conformance requirements

During POWER-on no transmissions shall occur from the MES.

Following POWER-on the MES shall enter a controlled, non-transmitting (carrier-off) state. This state shall be maintained whilst the MES is not synchronized with the appropriate network control channel(s).

Without synchronizing to the appropriate network control channel(s), it shall not be possible to initiate the carrier-on state.

Within 30 s of having lost the appropriate network control channel(s) the MES shall suppress transmissions (carrier-off).

The conformance requirements apply for the environmental conditions as specified in clause B.2.

8.3.1.3 Method of test

The MES shall be cycled through its power-on and power-off states. Attempts shall be made to initiate calls using normal user operational procedures. The transmitting state of the MES shall be monitored to ensure compliance with the test requirements.

The environmental test conditions are given in clause B.3.

8.3.1.4 Test procedure

The MES shall be situated in an environment where receipt of the appropriate network control channel(s) is controlled by the test laboratory.

- The MES shall be in a power-off state, situated such that it is not in receipt of the appropriate network control channel(s).
- The MES shall be powered-on.
- An attempt shall be made, using normal user operational procedures, to initiate a call.
- The appropriate network control channel(s) shall be activated and a call shall be initiated using normal user operational procedures.
- The appropriate network control channel(s) shall then be deactivated.
- An attempt shall be made, using normal user operational procedures, to initiate a call.
- The appropriate network control channel(s) shall be reactivated and a call shall be initiated using normal user operational procedures.

Throughout this procedure, the transmission state of the MES shall be monitored.

8.3.1.5 Test requirement

During and after test procedure step a), the MES shall be in power-off state.

During and after test procedure step b), no transmissions shall occur (carrier-off).

During and after test procedure step c), no transmissions shall occur (carrier-off).

After test procedure step d), the MES shall be transmitting (carrier-on).

Within 30 seconds of test procedure step e), MES transmissions shall cease (carrier-off).

During and after test procedure step f), no transmissions shall occur (carrier-off).

After test procedure step g), the MES shall be transmitting (carrier-on).

8.3.2 Network Control Reception

8.3.2.1 Transmission disable/enable

8.3.2.1.1 Purpose

Protection of radio services and systems from uncontrolled RF transmissions from the MES.

8.3.2.1.2 Conformance requirements

After power-on the MES shall remain in the carrier-off state until it receives a transmission enable command. For systems where no transmission enable command is expected after power-on the MES may only transmit initial bursts.

An MES which is transmitting (carrier-on) shall not continue transmissions for a period of time longer than 1 second after receipt of a transmission disable command. After ceasing transmissions the MES shall then not transmit until it receives a transmission enable command, or it is powered-off and then powered-on again. For systems where no transmission enable command is expected when not transmitting (carrier-off), the MES may only transmit initial bursts until it receives a transmission enable command, or until it is powered-off and then powered-on again.

An MES which is powered-on but not transmitting (carrier-off) when it is in receipt of a transmission disable command from its NCF shall then not transmit until it receives a transmission enable command from its NCF, or until it is powered-off and then powered-on again. For systems where no transmission disable command is expected when not transmitting (carrier-off) the MES may only transmit initial bursts until it receives a transmission enable command.

The initial bursts shall be subject to the following restrictions:

- a) an initial burst may be transmitted in a continuous or non-continuous mode (i.e. as a single burst or as a sequence of bursts);
- b) the carrier-on time of an initial burst transmission sequence shall not exceed one second;
- c) the total carrier-on time for multiple initial bursts shall not exceed 1 % of the time.

The conformance requirements apply for the environmental conditions as specified in clause B.2.

8.3.2.1.3 Method of test

The MES shall be sent transmission enable and transmission disable commands. Attempts shall be made to initiate calls using normal user operational procedures. The transmitting state of the MES shall be monitored to ensure compliance with the test requirements.

The method of enabling the MES in steps (d) and (g) of the test procedure shall be declared by the manufacturer. The declared method shall conform to the requirements defined in subclause 8.3.2.1.2.

The environmental test conditions are given in clause B.3.

8.3.2.1.4 Test procedure

The MES shall be situated in an environment where receipt of the appropriate network control channel(s) and of NCF commands is controlled by the test laboratory.

- a) The appropriate network control channel(s) shall be activated, the MES shall be powered-on, and a call shall be initiated using normal user operational procedures.
- b) An NCF command to disable transmissions shall be invoked with the STF and the STF shall transmit a transmission disable command to the MES.
- c) Whilst the disable command applies, an attempt shall be made to initiate a call using normal user operational procedures.
- d) The MES shall be enabled by performing the procedure declared by the manufacturer and a call shall be initiated using normal user operational procedures.
- e) The MES shall be set to a carrier-off state, and an NCF command to disable transmissions shall be invoked with the STF. The STF may transmit a transmission disable command to the MES.
- f) Whilst the disable command applies, an attempt shall be made to initiate a call using normal user operational procedures.
- g) The MES shall be enabled by performing the procedure declared by the manufacturer and a call shall be initiated using normal user operational procedures.

Throughout this procedure, the transmission state of the MES shall be monitored.

8.3.2.1.5 Test requirement

After test procedure step a), the MES shall be transmitting (carrier-on).

During test procedure step b), within 1 second of receipt of the transmission disable command by the MES, the MES transmissions shall cease (carrier-off).

During and after test procedure step c), only initial burst transmissions shall occur.

After test procedure step d), the MES shall be transmitting (carrier-on).

During and after test procedure steps e) and f), only initial burst transmissions shall occur.

After test procedure step g), the MES shall be transmitting (carrier-on).

Each initial burst transmission sequence shall have a total carrier-on time that is less than one second and the total carrier-on time for repeated initial bursts shall not exceed 1 % of the time.

8.3.2.2 Transmit frequency control

8.3.2.2.1 Purpose

Protection of radio services and systems from uncontrolled RF transmissions from the MES.

8.3.2.2.2 Conformance requirements

The MES shall set the carrier frequency of its transmission according to the command of the NCF. The carrier frequency has to be controlled such, that the entire nominated bandwidth of the terminal falls completely within the operational frequency band(s) specified by the applicant and declared by the applicant.

The conformance requirements apply for the environmental conditions as specified in clause B.2.

8.3.2.2.3 Method of test

The nominated bandwidth of the MES shall be monitored relative to the carrier frequency commanded, and relative to the operational frequency bands for the MES specified by the applicant.

The environmental test conditions are given in clause B.3.

8.3.2.2.4 Test procedure

This test shall be carried out at least twice, once for the minimum and once for the maximum MES transmit frequency for which the MES is designed to operate, as specified by the applicant.

Where available, two additional transmit frequencies shall also be tested. These frequencies shall be equally spaced between the minimum and maximum frequencies. The commanded transmit frequencies used for the test shall be entered in the test report.

The MES shall be situated in an environment where receipt of the network control channel(s) and of NCF commands is controlled by the test laboratory.

- a) The appropriate network control channel(s) shall be activated and the MES powered-on.
- b) An appropriate NCF control message shall be sent, commanding the MES to set its carrier frequency to one of the transmit frequencies to be tested.
- c) The test shall be repeated for the other transmit frequencies to be tested.

The carrier mask for the transmit frequency under test shall be monitored on a spectrum analyser, using the procedures given in subclause 6.4.

8.3.2.2.5 Test requirement

The MES shall set the centre frequency of its transmission according to the NCF command.

The entire nominated bandwidth for each transmit frequency tested shall be contained completely within the operational frequency band(s) specified by the applicant.

8.4 Fellow radio stations in a dual-mode or multi-mode terminal

8.4.1 Purpose

Protection of radio services and systems from uncontrolled RF transmissions from the MES.

8.4.2 Conformance requirements

Any fellow radio station in a multi-mode MES shall not transmit without reception of the appropriate network control channel(s) for the system for which it is designed. The conformance requirements apply for the environmental conditions as specified for the fellow radio station.

8.4.3 Method of test

The MES shall be placed in a suitable environment which isolates the MES from the networks of each of its fellow modes. It shall be verified that no transmissions are made from any of the fellow modes.

8.4.4 Test procedure

The MES shall be placed in an environment where the receipt of the appropriate network control channel(s) of all the fellow modes is prevented. For each fellow mode radio station, an attempt shall be made, using normal user operational procedures, to initiate a call. Throughout this procedure, the transmission state of the MES shall be monitored.

8.4.5 Test requirements

Throughout the test procedure, no transmission shall occur.

9 Equipment identity

9.1 Purpose

Protection of radio services and systems from uncontrolled RF transmissions from the MES.

9.2 Conformance requirements

Each MES shall have a unique MES Identification Code (MIC) within its S-PCN.

It shall not be possible for the user to alter the MIC using any normally accessible procedure.

The MES shall be capable of transmitting its MES Identification Code upon reception of an appropriate NCF command addressed to it.

The conformance requirements apply for the environmental conditions as specified in clause B.2.

9.3 Method of test

It is impracticable to test that each MES has a unique MES Identification Code (MIC) within its S-PCN, and that it is not possible for the user to alter the MIC using any normally accessible procedure. Consequently, no tests are given for these requirements.

The transmissions of the MES in response to an NCF command to send its MES Identification Code shall be monitored and the identification code received shall be verified.

The environmental test conditions are given in clause B.3.

9.4 Test procedure

The MES shall be situated in an environment where receipt of the appropriate network control channel(s) and of NCF commands is controlled by the test laboratory.

- a) The appropriate network control channel(s) shall be activated and the MES powered-on.
- b) An appropriate NCF control message shall be sent, commanding the MES to transmit its MES Identification Code.
- c) The message sent by the MES shall be analysed.

9.5 Test requirements

The MES identification code in the message sent in step c) shall be verified against that supplied by the applicant for the MES.

10 Protection of the radio astronomy service operation in the band 1 660 MHz to 1 660,5 MHz

10.1 Purpose

To protect the radio astronomy service in the 1 660 MHz to 1 660,5 MHz band from emissions produced by MESs.

10.2 Conformance requirements

Covered by subclause 8.3.2.1.2.

This is a minimum requirement for the purposes of demonstrating compliance with the essential requirements under SES Directive Articles 4.1 and 4.3. The actual procedure used in an S-PCN network to protect the radio astronomy service in the 1 660 MHz to 1 660,5 MHz band may utilize additional features of the MES.

10.3 Method of test

Covered by subclause 8.3.2.1.3.

10.4 Test procedure

Covered by subclause 8.3.2.1.4.

10.5 Test requirements

Covered by subclause 8.3.2.1.5.

Annex A (normative): General test requirements

A.1 MES test modes

The MES is required to be placed in a number of different test modes in order for the various tests specified within the present document to be carried out:

- 1) power-off;
- 2) power-on (applies to all the following test modes);
- 3) carrier-off;
- 4) carrier-on, maximum transmit power, in a specified channel in an operational band, transmitting with a specified transmission format and modulated with the test modulating signal as specified in subclause A.2.3;
- 5) carrier-on, maximum transmit power, in a specified channel in an operational band, set by NCF command, transmitting with a specified transmission format and modulated with the test modulating signal as specified in subclause A.2.3;

NOTE: If this is available for all tests (4) is not required separately.

- 6) carrier-on at any detectable power.

The MES may be placed into test modes 4 and 5 either by means of a special facility existing internally in the MES, or by means of a Special Test Equipment (STE).

If the MES has been modified by the applicant for these tests, then full documentation showing such modification(s) shall be provided to demonstrate that the modification(s) will not cause the test results to deviate from normal operational performance.

A.2 Special Test Equipment

A.2.1 STE description

The STE shall provide the necessary facilities for tests which require that the MES be operated in its normal operating manner, situated in an environment where receipt of the appropriate network control channel(s) and of NCF commands is under the control of the test laboratory.

The STE shall also provide means for the test laboratory to interface its test equipment with the MES for the purpose of monitoring the MES responses.

For other tests, where the required test mode cannot be, or is not, provided by a special test facility within the MES, then STE shall also provide the facility to put the MES into these required test modes.

A.2.2 Use of STE for control and monitoring functions tests

The test arrangement shall be as shown in figure A.1 for radiated and conducted measurements.

This test arrangement assumes that the STE is responsible for simulating the NCF commands and/or the appropriate network control channel(s) in the same way as they are received by the MES in normal operating mode. The response received by the STE from the MES shall be routed to the LTE without modification that would significantly affect the measurement.

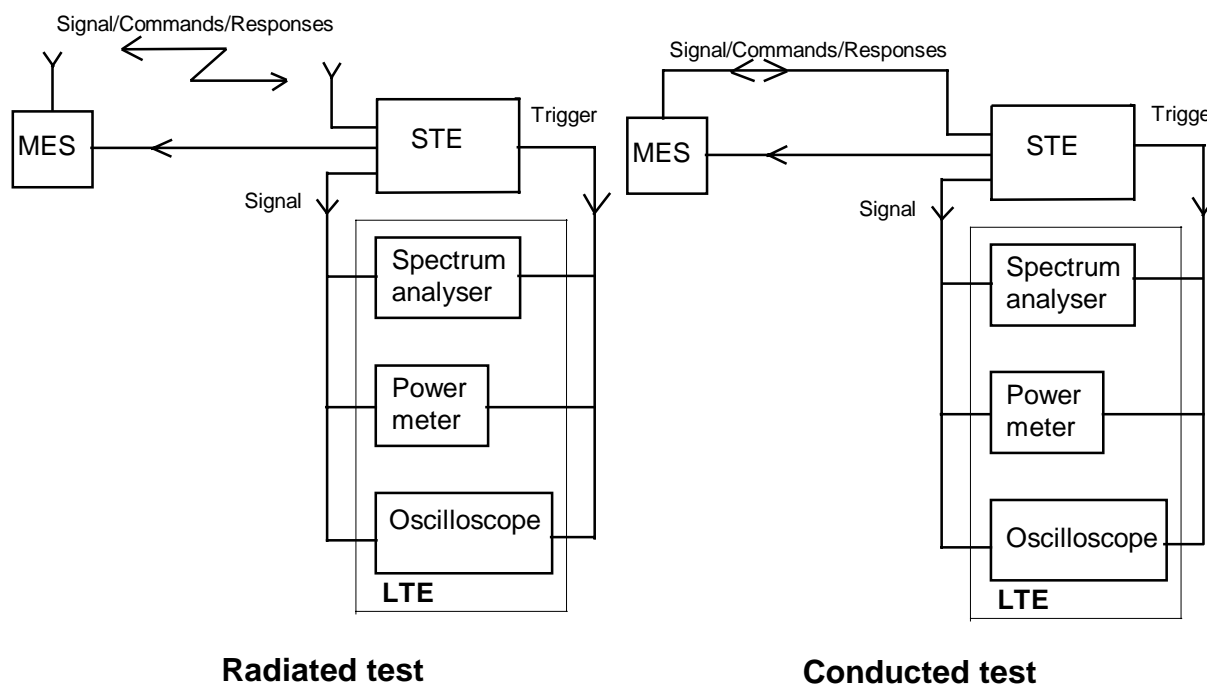

Figure A.1: General test arrangement for control and monitoring tests

The dual trace storage oscilloscope, or other suitable method, may be used to monitor the response of the MES to the simulated events by measuring the time difference between the event or command reception, and the compliance with that event.

The power meter and spectrum analyser shall be used to monitor the MES output signal during all the test procedure.

A.2.3 Test modulating signal

The test modulating signal is a baseband signal which modulates the carrier of the MES and is dependent upon the type of equipment under test. It is a signal representing a pseudo-random bit sequence of at least 511 bits in accordance with ITU-T Recommendation O.153 [1]. This sequence shall be continuously repeated and shall be at the maximum bit rate declared by the applicant at which the MES is able to operate.

If not internally generated by the MES, this test modulating signal shall be provided by the STE.

A.3 Laboratory Test Equipment (LTE)

The Laboratory Test Equipment (LTE) is a logical grouping that contains the measurement equipment provided by the test laboratory.

It shall be verified that the responses of the LTE, including any test antenna, to a constant amplitude sine wave signal remain within ± 1 dB of calibration across the frequency range of interest.

The maximum values of measurement uncertainty for the LTE associated with each measurement parameter given in table A.1 for a 95 % confidence level, shall apply as appropriate to the test cases described in the present document.

Table A.1: Measurement uncertainties

Measured parameter	Measurement uncertainty
Radio Frequency above 1 MHz	± 1 part in 10^7
EIRP density within the operational band	$\pm 0,75$ dB
Unwanted radiated emissions	± 6 dB
Unwanted conducted emissions	± 4 dB

A.4 Methods of test for MES RF emissions

Measurements shall be performed according to the equipment type:

Table A.2: Options for testing

Equipment with passive antenna port available (external, internal or temporary)	Radiated from cabinet from 30 MHz to 4 GHz (passive antenna port connected to a dummy load), and conducted from the passive antenna port, from 100 kHz to 12,75 GHz.
Equipment with no passive antenna port available (see note)	Radiated from complete MES, including its antenna, from 30 MHz to 12,75 GHz.
NOTE: Equipment with an active antenna shall assume to have no antenna port available.	

The methods of measurement for radiated emissions are described in annex C.

The methods of measurement for conducted emissions are described in annex D.

A.5 Interpretation of the measurement results

The interpretation of the results for the measurements described in the present document shall be as follows:

- a) the measured value related to the corresponding limit shall be used to decide whether an equipment meets the minimum requirements of the standard;
- b) the actual measurement uncertainty of the test laboratory carrying out the measurement, for each particular measurement, shall be included in the test report;
- c) the values of the actual measurement uncertainty shall be, for each measurement, equal to or lower than the figures in clause A.3.

A.6 Test report

All results of the tests performed shall be recorded in a test report.

For each test, the test report shall also include the test conditions (status of the MES, frequency of operation, transmission format), the measurement uncertainties and the environmental test conditions.

Annex B (normative): Environmental conditions and host connected equipment

B.1 General

This normative annex specifies the environmental conditions under which the relevant requirements of the present document shall be fulfilled.

B.2 Environmental requirements

B.2.1 Temperature

The MES shall fulfil all the requirements in the full temperature ranges of:

- -10°C to +55 C;

(taken from IEC 60068-2-1 [3] and IEC 60068-2-2 [4]).

B.2.2 Voltage

The applicant shall declare the nominal, lower and the higher extreme voltages.

The MES shall fulfil all the requirements in the full voltage range between the extreme voltages.

B.2.3 Vibration

The MES shall fulfil all the requirements when vibrated at the frequency/amplitudes given in table B.1.

Table B.1: Vibration characteristics

Frequency range	ASD (Acceleration Spectral Density) random vibration
5 Hz to 20 Hz	0,96 m ² /s ³ (+0 %/-5 %)
20 Hz to 500 Hz	0,96 m ² /s ³ (+0 %/-5 %) at 20 Hz, thereafter -3 dB/Octave (+0 %/-5 %) (taken from IEC 60068-2-36 [5])

B.3 Environmental test conditions

B.3.1 Specification of the environmental test conditions

The tests in clauses 5, 6 and 7 shall be performed under the conditions given in table B.2.

Table B.2: Environmental test conditions

Equipment Category	Temperature	Voltage
handheld	Normal	Normal condition voltage (± 1 %)
other than handheld	Normal	Higher extreme voltage (+0 %/-2 %)
other than handheld	Normal	Lower extreme voltage (-0 %/+2 %)

Normal temperature shall be between +15°C and +35°C.

All other tests shall be performed under normal conditions for temperature and voltage, and without vibration.

B.3.2 Tests under extreme voltage conditions

During tests under extreme voltage conditions, the power source of the equipment shall be replaced by a test power source, capable of producing extreme test voltages as specified in subclause B.3.1. The internal impedance of the test power source shall be low enough for its effect on the test results to be negligible. For the test purposes, the voltage of the power source shall be measured at the input terminals of the equipment.

If the equipment is provided with a permanently connected power cable, the test voltage shall be measured at the point of connection of the power cable to the equipment.

In equipment with incorporated batteries, the test power source shall be applied as close to the battery terminals as is practical. In each case connections shall be made readily available by the applicant.

During tests, the power source voltages shall be maintained within a tolerance of ± 3 % relative to the voltage at the beginning of each test.

B.4 Testing of host-connected equipment and plug-in modules

For equipment for which connection to or integration with host equipment is required to offer functionality, two alternative approaches are permitted. The applicant shall declare which alternative shall be used.

B.4.1 Alternative A: combined equipment

Under alternative A, a combination of MES and a specific type of host equipment shall be used for testing according to the present document.

Where more than one such combination is intended, testing shall not be repeated for combinations of MES and other host equipment where the latter are substantially similar, in particular such that the host models are unlikely to significantly influence the emissions of the MES.

Where more than one such combination is intended and host equipment are not substantially similar, one combination shall be tested against the full set of requirements of the present document; other combinations shall be tested separately for radiated emissions only.

B.4.2 Alternative B: use of a test jig

Under alternative B, where the MES is intended for use with a variety of host equipment, the applicant shall supply a suitable test jig that is representative of the range of host equipment in which the MES may be used. In particular, the test jig shall be designed such that any alteration of the MES's emissions is minimized. The test jig shall allow the MES part to be powered and stimulated in a way similar to the way it would be powered and stimulated when connected to or inserted into the host equipment.

The MES shall be tested against the full set of requirements of the present document.

Annex C (normative): Procedures for measurement of radiated emissions

C.1 General

This annex contains methods for tests involving the measurement of a radiated field. This field may be radiated by an antenna and/or by the cabinet of the equipment itself.

It is recognized that for some parameters, alternative test methods may exist. It is the responsibility of the test laboratory to ensure that any alternative test method used yields results identical to those described in the present document.

C.1.1 Test site

The standard test site shall be a calibrated open air test site, whose dimensions are appropriate to the frequency range of measurements.

All radiated measurement tests shall be conducted in such a way as to ensure that there is no interference to operational satellite and terrestrial systems. In some cases operating on a test site may produce electromagnetic perturbation or, conversely, external radiation may disturb the measurement. For these reasons, and also in order to reduce the space required, or to perform tests under extreme environmental conditions, other arrangements may be used, such as:

- anechoic chamber;
- indoor test site.

In addition, it shall be verified that the test site shall be suitable with respect to ambient noise which shall be at least 6 dB lower than the lowest specification value being measured.

The methods of measurement described in this annex are based on an open air test site. If an anechoic chamber or an indoor test site are used, some changes may apply to the method of measurement. For each radiated measurement, the nature and the dimensions of the test arrangement used shall be recorded in the test report.

C.1.2 Test set up for radiated emissions of the MES

The tests shall be carried out with the MES at the specified environmental conditions and for the specified power supply voltages.

For IE, EME and IME it shall be installed with a separation of approximately 0,5 m. Between the two equipment, the maximum length connection cable specified by the applicant shall be installed. The height of the cable shall be between 0,5 m and 1 m. The cable shall be maintained in that position by non-metallic means. The EME shall be set, in its normal operating configuration on a non-conducting support at a height between 0,5 m and 1 m. The IME shall be set on a non-conducting support at a height between 0,5 m and 1 m. Any associated equipment, if required for normal operation of the MES, shall be placed next to, and at the same height as the IME.

For PE, the equipment shall be arranged in its normal operating configuration as recommended by the applicant on a non-metallic table at a height between 0,5 m and 1 m.

The MES under test shall be placed on the support in its standard position and shall be switched-on.

Each antenna (MES antenna and test antenna) shall be positioned to be outside the near field of the other antenna.

The spectrum analyser noise floor shall be at least 6 dB below the minimum value to be measured.

C.1.3 Reference position of the MES

During radiated measurements, the MES is required to be oriented specifically in relation to the test antenna connected to the LTE. This position is called the reference position and is determined as follows:

- The MES shall be placed in a mode whereby it is transmitting.
- The MES shall be rotated in both horizontal and vertical planes in order to locate the direction of maximum field strength that is detected by the test antenna. This orientation shall be called the reference position.

C.2 Measurement procedure for radiated emissions (peak)

C.2.1 Measurement procedure for peak radiated emissions of the MES

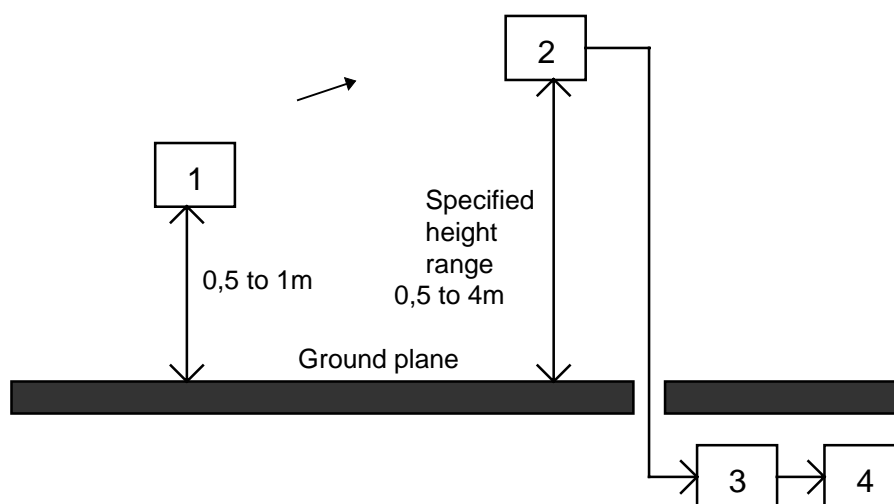

NOTE:

- 1) MES under test (with antenna);
- 2) Test antenna;
- 3) Input filter (if necessary);
- 4) Spectrum analyser.

Figure C.1: Measurement arrangement No.1

Measurement arrangement No.1 of figure C.1 shall be used.

- a) For each measurement bandwidth, the following actions shall be performed:
- The MES shall be placed in the reference position as described in subclause C.1.3.
 - The test antenna shall have the same polarization as the MES and connected to a spectrum analyser, eventually through a suitable entry filter to avoid overloading of the spectrum analyser.
 - Precautions may be required to ensure that the filter does not attenuate the harmonics of the carrier.
 - The test antenna and the entry filter shall be suitable for the measured frequency band, and replaced by other each time it will be necessary.
 - The spectrum analyser shall be tuned to the measurement bandwidth to analyse.
 - The resolution bandwidth of the spectrum analyser shall be set to a suitable value to correctly perform the measurement, and the peak hold function shall be activated. The video bandwidth shall be set to at least 3 times the resolution bandwidth.
- b) Only the discrete signals having a level equal or greater than 6 dB below the specified limit shall be precisely measured.
- The test antenna shall be raised or lowered through the specified height range to look for the maximum signal on the spectrum analyser (this may not be necessary if the test site is an anechoic chamber or an indoor test site).
 - The maximum measured value shall be recorded.
- c) The procedure is repeated from a) to b) with the other measurement bandwidths to cover all the frequency range to be analysed.
- d) In the case where the test site has been calibrated before, the absolute measurement is sufficient to determine the actual value of EIRP of the radiated emissions. The precise knowledge of distance between the MES and the test antenna, and the characteristics of the test antenna and the input filter allow the determination of the EIRP radiated by the MES.
- e) In the case where the test site cannot be calibrated, a relative measurement can be done according to the following procedure:

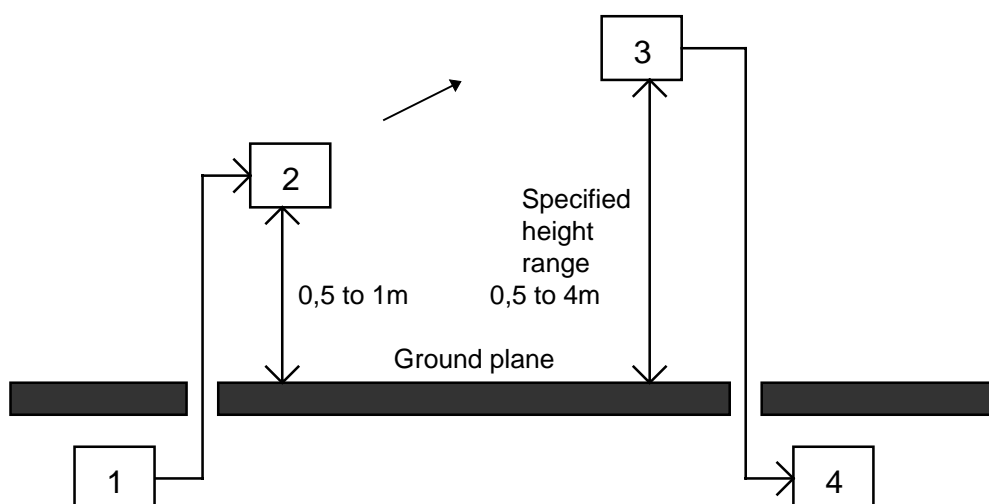

NOTE:

- 1) Sinusoidal RF signal generator;
- 2) Substitution antenna;
- 3) Test antenna;
- 4) Spectrum analyser.

Figure C.2: Measurement arrangement No.2

Using measurement arrangement No.2 of figure C.2, a substitution antenna shall replace the MES in the same position where was the MES antenna. It shall be connected to the signal generator.

- a) The signal generator shall be tuned to each frequency at which an emission has been detected in the case of unwanted emissions measurement, or to the frequency at the middle of each measurement bandwidth in the case of EIRP density measurement, The substitution antenna shall be suitable for this frequency.
 - The spectrum analyser shall be tuned to the measurement bandwidth to analyse and put in the same conditions as for the measurement with the MES, with the peak hold function activated.
 - The level of the signal generator shall be adjusted to give the same signal level on the spectrum analyser as in b).
 - The output level of the signal generator shall be recorded. This value, after corrections due to the gain of the substitution antenna and the cable loss between the signal generator and the substitution antenna, is the radiated emission level of the MES.
- b) The f) procedure is repeated with the other measurement bandwidths to cover the whole frequency range to be analysed.
- c) a) to g) shall be repeated with test antennas of the opposite polarization for the unwanted emission measurements.

C.2.2 Measurement procedure for peak radiated emissions of the cabinet

This method of measurement applies to transmitters having an antenna socket and has to be performed in addition to conducted measurements of the MES in the case of unwanted emissions.

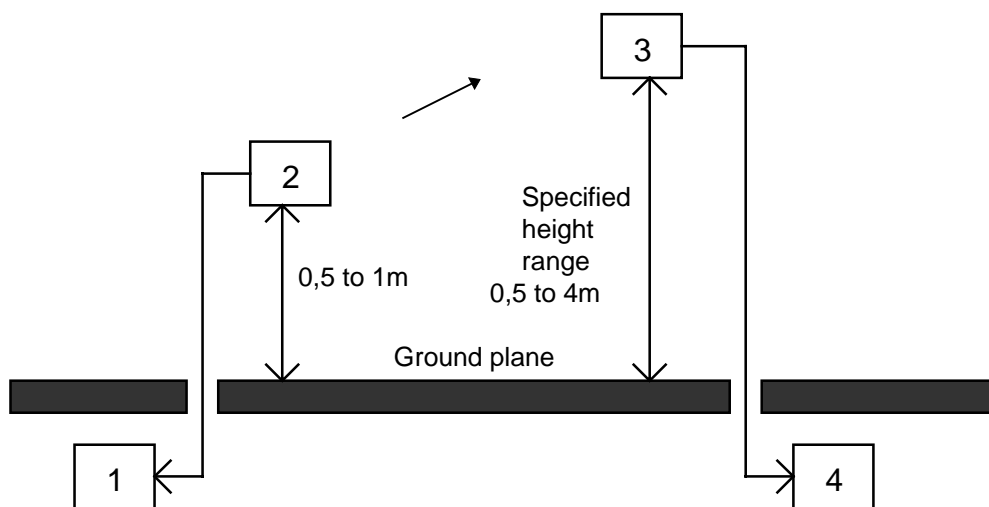

NOTE:

- 1) Test load;
- 2) MES under test (antenna port connected to the test load);
- 3) Test antenna;
- 4) Spectrum analyser.

Figure C.3: Measurement arrangement No.3

Measurement arrangement No.3 of figure C.3 shall be used for measurement of radiated emissions of the cabinet.

The procedure is a peak measurement as in subclause C.2.1.

The same method as in subclause C.2.1 shall be applied with the exception that measurement arrangement No.3 replaces measurement arrangement No.1 (measurement arrangement No.2 remains the same for the relative measurement).

C.3 Measurement procedure for radiated emissions (average)

C.3.1 Measurement procedure for average radiated emissions of the MES

Measurement arrangement No.1 of figure C.1 shall be used.

- a) For each measurement bandwidth, the following actions shall be performed:
 - The MES shall be placed in the reference position as described in subclause C.1.3.
 - The test antenna shall have the same polarization as the MES and connected to a spectrum analyser, eventually through a suitable entry filter to avoid overloading of the spectrum analyser.
 - Precautions may be required to ensure that the filter does not attenuate the harmonics of the carrier.
 - The test antenna and the entry filter shall be suitable for the measured frequency band, and replaced by other each time it will be necessary.
 - The spectrum analyser shall be tuned to the measurement bandwidth to analyse.
 - The resolution bandwidth of the spectrum analyser shall be set to a suitable value to correctly perform the measurement, and the average function shall be activated. The video bandwidth shall be set to the same value as the resolution bandwidth.
- b) The test antenna shall be raised or lowered through the specified height range to look for the maximum received signal on the spectrum analyser (this step may not be necessary if the test site is an anechoic chamber or an indoor test site).
 - The EIRP shall be averaged until the variance over the measured bandwidth is less than 1 dB. The averaged value shall be recorded.
- c) The procedure shall be repeated from a) to b) with the other measurement bandwidths to cover the whole frequency range to be analysed.
- d) In the case where the test site has been calibrated before, the absolute measurement is sufficient to determine the actual value of EIRP of the radiated emissions. The precise knowledge of distance between the MES and the test antenna, the characteristics of the test antenna and the input filter allow the determination of the EIRP radiated by the MES.
- e) In the case where the test site cannot be calibrated, a relative measurement can be done according to the following procedure:
 - Using measurement arrangement No.2 of figure C.2, a substitution antenna shall replace the MES in the same position where was the MES antenna. It shall be connected to the signal generator.
- f) The signal generator shall be tuned to the centre frequency of each measurement bandwidth. The substitution antenna shall be suitable for this frequency.
 - The spectrum analyser shall be tuned to the measurement bandwidth to analyse and put in the same conditions as for the measurement with the MES with the average function activated.
 - The level of the signal generator shall be adjusted to give the same signal level on the spectrum analyser as in b) when averaged until the variance over the measured bandwidth is less than 1 dB. The output level of the signal generator shall be recorded.
 - This value, after corrections due to the gain of the substitution antenna and the cable loss between the signal generator and the substitution antenna, is the radiated emission level of the MES.

- g) The f) procedure shall be repeated with the other measurement bandwidths to cover the whole frequency range to be analysed.
- h) a) to g) shall be repeated with test antennas of the opposite polarization for the unwanted emission measurements.

C.3.2 Measurement procedure for average radiated emissions of the cabinet

This method of measurement applies to transmitters having an antenna socket and has to be performed in addition to conducted measurements of the MES for unwanted emissions.

Measurement arrangement No.3 of figure C.3 shall be used for measurement of radiated emissions of the cabinet.

The procedure is an average measurement as in subclause C.3.1.

The same method as in subclause C.3.1 shall be applied with the exception that measurement arrangement No.3 replaces measurement arrangement No.1 (measurement arrangement No.2 remains the same for the relative measurement).

Annex D (normative): Procedures for measurement of conducted emissions

D.1 General

This annex contains the procedure for conducted emission measurements.

It is recognized that for some parameters, alternative test methods may exist. It is the responsibility of the test laboratory to ensure that any alternative test method used yields results identical to those described in the present document.

D.1.1 Test site

There are no specific requirements for the test site for conducted measurements except that they shall be performed in such a way as to ensure that there is no interference to operational satellite and terrestrial systems.

D.1.2 Test set-up

Measurement arrangement of figure D.1 shall be used.

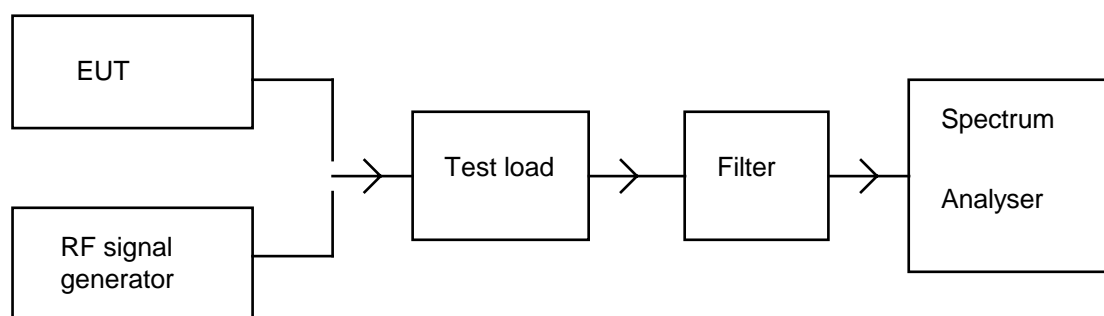

Figure D.1: Measurement arrangement for conducted emissions

The antenna port of the MES shall be connected to a spectrum analyser through a test load and eventually an appropriate filter to avoid overloading of the spectrum analyser.

Precautions may be required to ensure that the test load does not generate or that the filter does not attenuate, the harmonics of the carrier. The entry filter shall be suitable for the measured frequency band, and replaced by another each time it will be necessary.

The spectrum analyser noise floor shall be at least 6 dB below the minimum value to be measured.

D.2 Measurement procedure for conducted emissions (peak)

- a) For each measurement bandwidth, the following actions shall be performed:
 - The spectrum analyser shall be tuned to the measurement bandwidth to analyse.
 - The resolution bandwidth of the spectrum analyser shall be set to a suitable value to correctly perform the measurement, and the peak hold function shall be activated. The video bandwidth shall be set to at least 3 times the resolution bandwidth.
- b) The peak power detected value of each discrete signal having a level equal or greater than 6 dB below the specified limit shall be recorded.
- c) The procedure shall be repeated from a) to b) with the other measurement bandwidths to cover all the spectrum band which is required to be measured.
- d) The actual value of EIRP of the equivalent radiated emissions in each measurement bandwidth shall be derived by adding either the MES maximum antenna gain or the declared gain at the spurious emission frequency to the power value read from the spectrum analyser.

D.3 Measurement procedure for conducted emissions (average)

- a) For each measurement bandwidth, the following actions shall be performed:
 - The resolution bandwidth of the spectrum analyser shall be set to a suitable value to correctly perform the measurement, and the average function shall be activated. The video bandwidth shall be set to the same value as the resolution bandwidth.
 - The measurement time should be such that the difference of the measured levels, averaged over subsequent measurement samples, is less than 1 dB, or a measurement time of 100 ms may be used if the measured values comply with the applicable limits.
- b) The averaged power density value within the measured bandwidth shall be recorded.
- c) The procedure shall be repeated from a) to b) with the other measurement bandwidths to cover the whole frequency range to be analysed.
- d) The actual value of EIRP of the radiated emissions in each measurement bandwidth shall be derived by adding the MES maximum antenna gain measured at the normal operating frequency to the power spectral density value read from the spectrum analyser.

Annex E (informative): Explanation of nominated bandwidth

E.1 Introduction

This annex contains a graphical representation of the nominated bandwidth definition given in subclause 3.1.

E.2 Interpretation of Parameters [B_n, f_c, a, b]

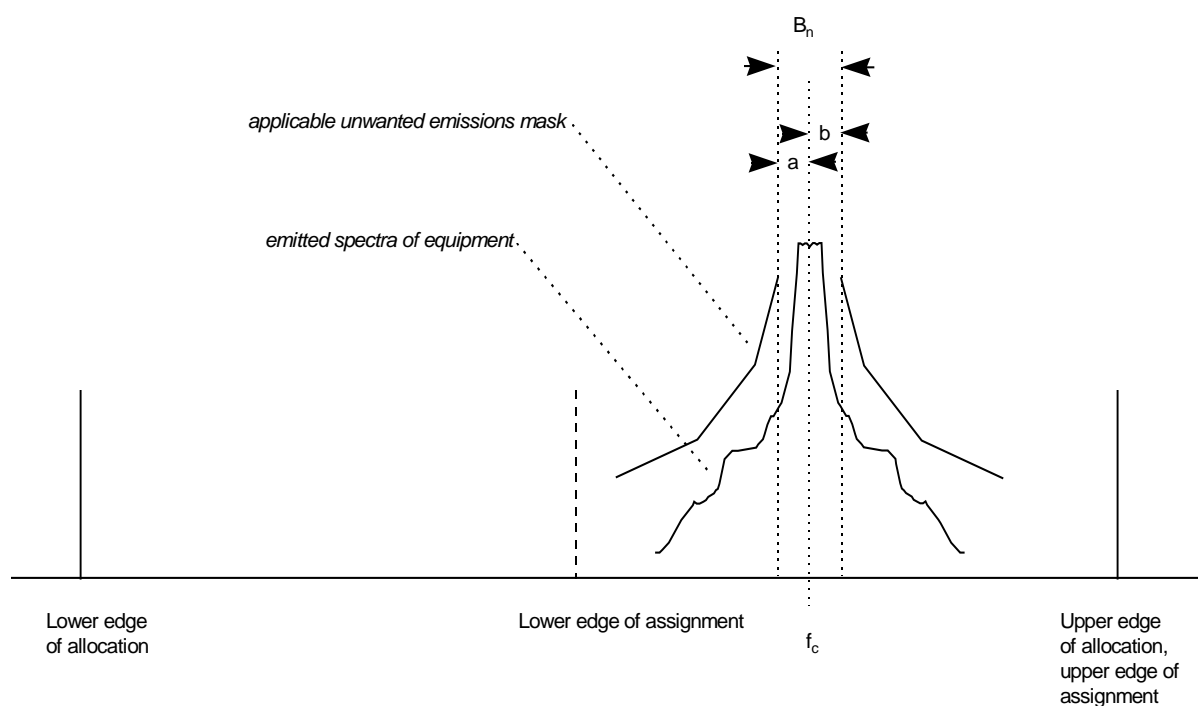

Figure E.1: Nominated bandwidth and Unwanted Emissions Mask

The centre frequency of the emitted spectra has been defined as f_c ; the values of a and b define the *nominated bandwidth* B_n . The value of B_n is chosen, such that the unwanted emissions mask is not exceeded by the emitted spectra in this example, it can be seen that the nominated bandwidth could be reduced without exceeding the limits of the mask.

E.3 Choice of nominated bandwidth

The choice of the nominated bandwidth is made by the applicant according to the bandwidth and shape of the spectral emission of the equipment. The optimum choice of nominated bandwidth will maximize the available operating frequency range of the MES, and this is achieved by selecting nominated bandwidth as narrow as possible without exceeding the applicable unwanted emissions masks. To illustrate this, two examples are given in figure E.2. The figures show occupied channels represented by carrier frequency (f_1, f_2) and the unwanted emission mask.

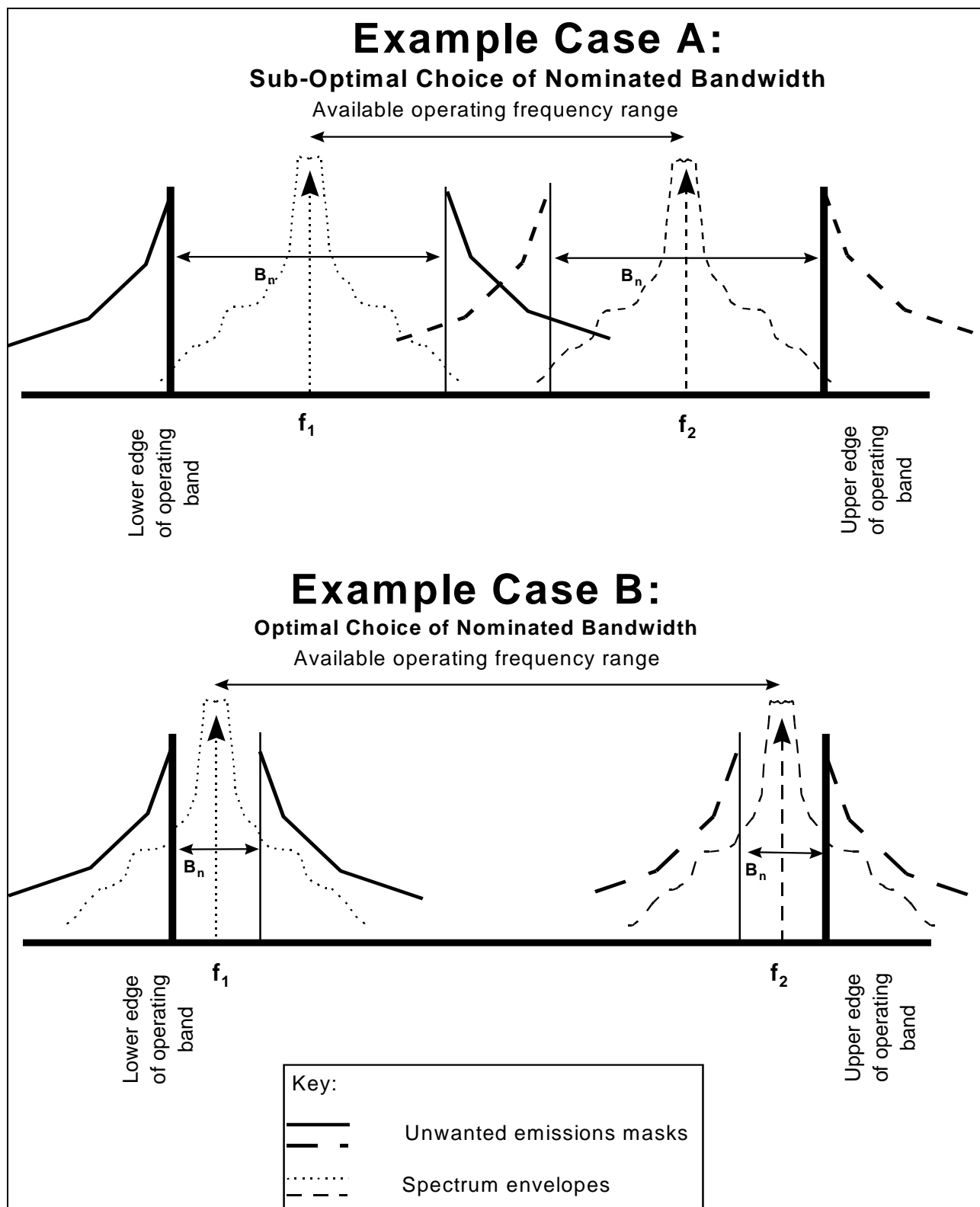

Figure E.2: Choice of nominated bandwidth

In Case A, the lower carrier (centre frequency f_1) is shown operating at its lowest allowable frequency, with the nominated bandwidth adjacent to the edge of the assignment. Similarly, the upper carrier is shown in the highest allowable frequency, centre frequency f_2 . The available tuning range for the carrier is shown.

In Case B, a similar situation is shown, but with a smaller nominated bandwidth. The uppermost and lowermost channels are operating closer to the band edges, and thus the available tuning range is greater.

E.4 Maximum value for nominated bandwidth

The maximum value for the nominated bandwidth (B_n) is defined in subclause 3.1 so that the frequency interval ($f_c - a$, $f_c + b$) shall not encompass more than either:

1. when $a = b$, 4 nominal carrier frequencies (i.e. five channel spacing) for narrow-band systems;
2. when $a \neq b$, 1 nominal carrier frequency (i.e. two channel spacing) for narrow-band systems; or
3. nominal carrier frequency (i.e. two channel spacing) for wide-band systems.

NOTE: In the following diagrams, f_c represents the actual frequency of transmission.

For case (1), the maximum value for the value of B_n is thus:

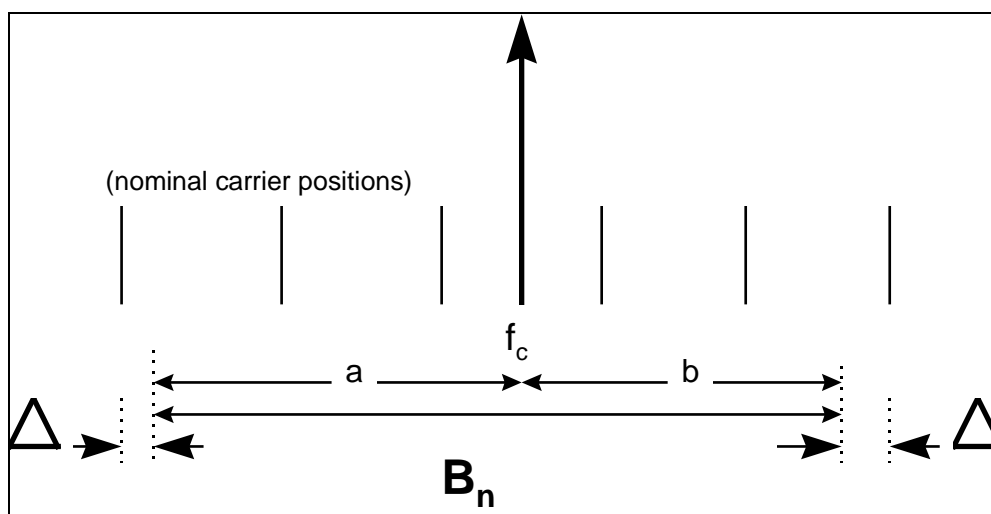

Figure E.3: Maximum value of nominated bandwidth for Case (i)

(When Δ is very small, B_n approaches 5 channel spacing and contains only 4 nominal carriers).

For case (2), the maximum value for the value of B_n is thus:

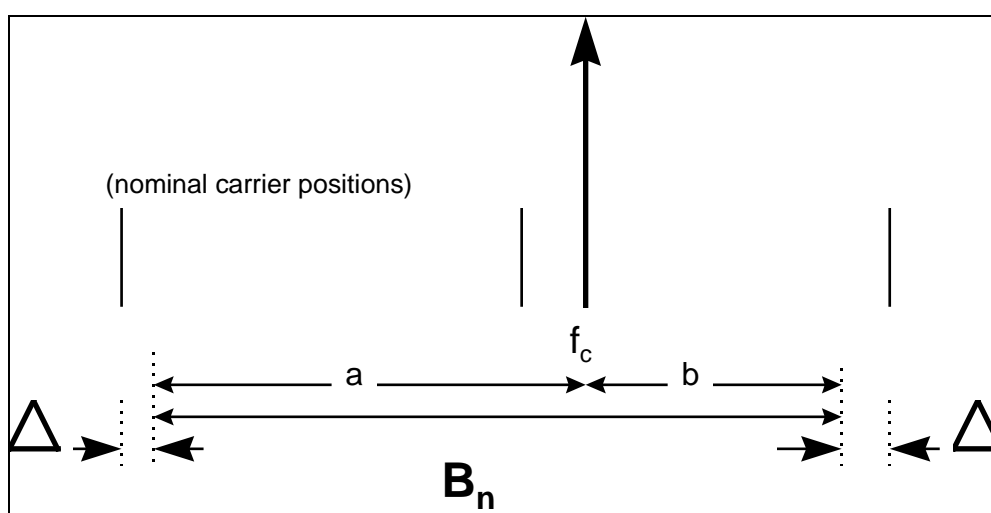

Figure E.4: Maximum value of nominated bandwidth for Case (ii)

(When Δ is very small, B_n approaches 2 channel spacing and contains only 1 nominal carrier).

For case (3), where the values of a and b are equal, the maximum value for the value of B_n is thus:

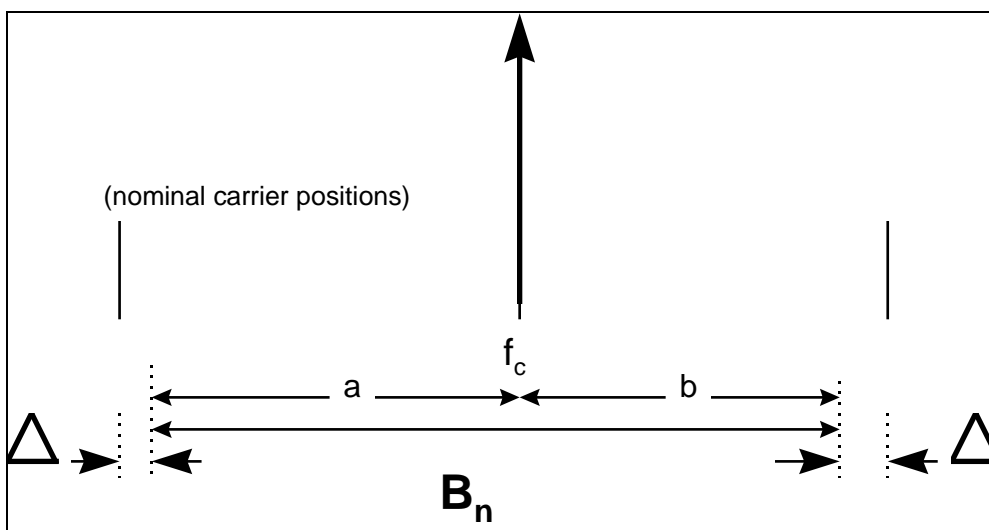

Figure E.5: Maximum value of nominated bandwidth for Case (iii)

(When Δ is very small, B_n approaches 2 channel spacing and contains only 1 nominal carrier).

For case (3), where the values of a and b are not equal, the maximum value for the value of B_n is thus:

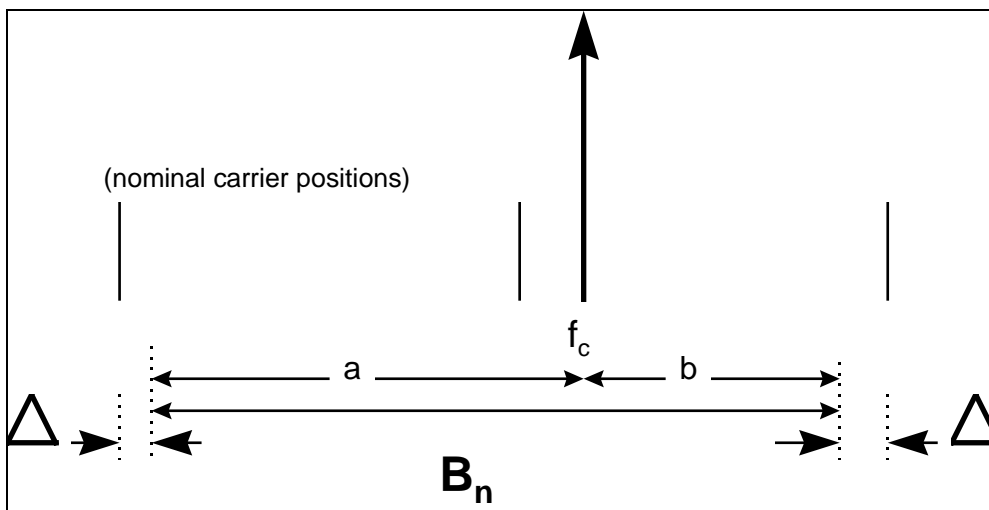

Figure E.6: Maximum value of nominated bandwidth for Case (iii)

(When Δ is very small, B_n approaches 2 channel spacing and contains only 1 nominal carrier).

Bibliography

The following material, though not specifically referenced in the body of the present document (or not publicly available), gives supporting information.

Council Directive 93/97/EEC of 29 October 1993 supplementing Directive 91/263/EEC in respect of satellite earth station equipment (Satellite Earth Station or SES Directive).

Council Directive 91/263/EEC of 29 April 1991 on the approximation of the laws of the Member States concerning telecommunications terminal equipment, including the mutual recognition of their conformity (Terminal or TTE Directive).

Council Directive 73/23/EEC of 19 February 1973 on the harmonization of the laws of the Member States relating to electrical equipment designed for use within certain voltage limits (Low Voltage Directive).

Council Directive 92/31/EEC of 28 April 1992 amending Directive 89/336/EEC on the approximation of the laws of the Member States relating to electromagnetic compatibility (EMC Directive).

CEN/CENELEC EN 55022: "Limits and methods of measurements of radio disturbance characteristics of information technology equipment".

Construction of an Anechoic Chamber: Technical Report ZVEI AK-R 90/20.

History

Document history			
V1.1.2	December 1999	Public Enquiry	PE 200015: 1999-12-15 to 2000-04-14