

# ETSI EN 301 649 V1.1.1 (2000-03)

---

*European Standard (Telecommunications series)*

## **Digital Enhanced Cordless Telecommunications (DECT); DECT Packet Radio Service (DPRS)**

---

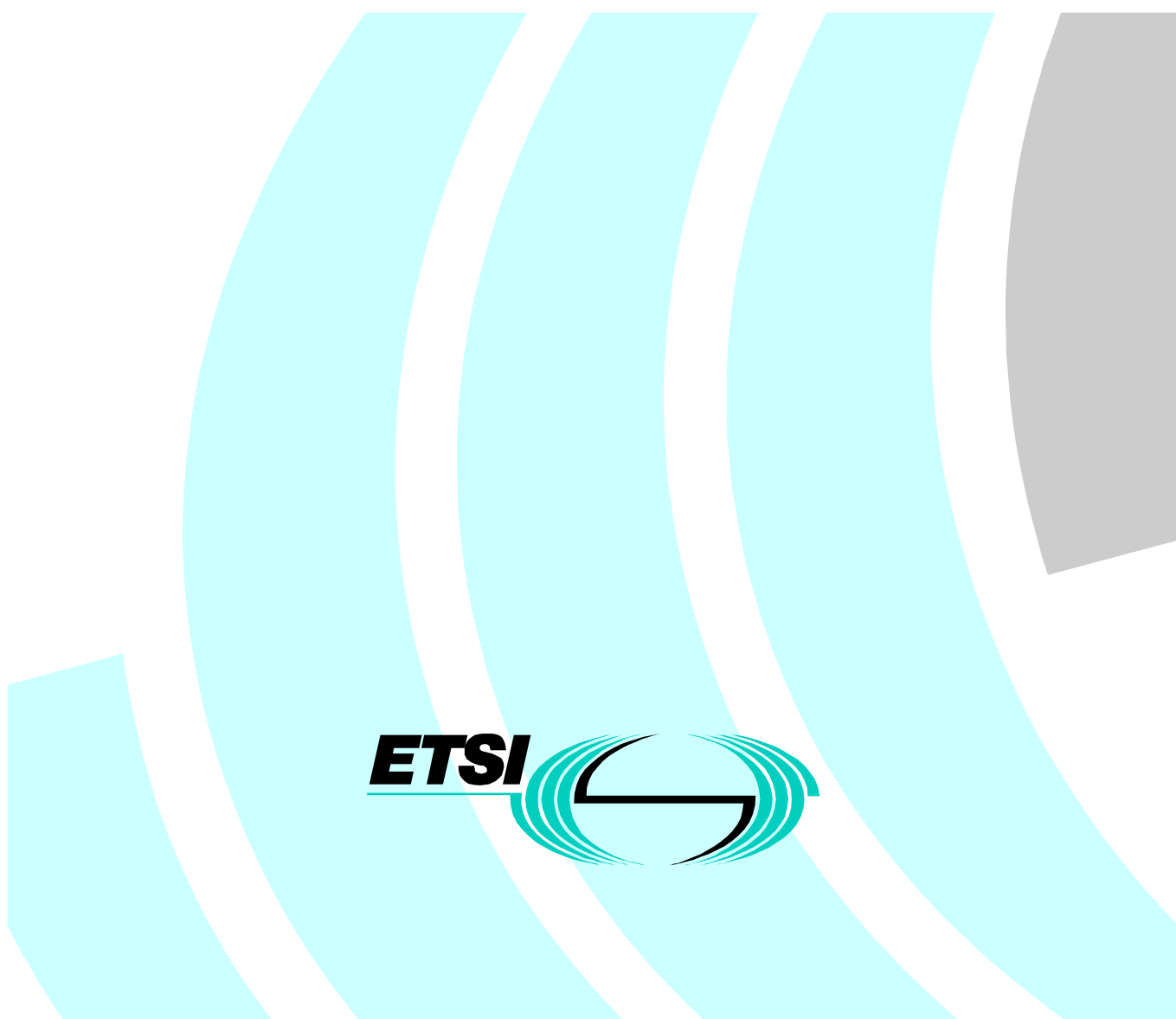

---

**Reference**DEN/DECT-020159

---

---

**Keywords**data, DECT, mobility, profile, radio

---

**ETSI**

---

**Postal address**F-06921 Sophia Antipolis Cedex - FRANCE

---

---

**Office address**

650 Route des Lucioles - Sophia Antipolis  
Valbonne - FRANCE  
Tel.: +33 4 92 94 42 00 Fax: +33 4 93 65 47 16  
Siret N° 348 623 562 00017 - NAF 742 C  
Association à but non lucratif enregistrée à la  
Sous-Préfecture de Grasse (06) N° 7803/88

---

**Internet**

secretariat@etsi.fr  
Individual copies of this ETSI deliverable  
can be downloaded from  
<http://www.etsi.org>  
If you find errors in the present document, send your  
comment to: editor@etsi.fr

---

**Important notice**

---

This ETSI deliverable may be made available in more than one electronic version or in print. In any case of existing or perceived difference in contents between such versions, the reference version is the Portable Document Format (PDF). In case of dispute, the reference shall be the printing on ETSI printers of the PDF version kept on a specific network drive within ETSI Secretariat.

---

**Copyright Notification**

---

No part may be reproduced except as authorized by written permission.  
The copyright and the foregoing restriction extend to reproduction in all media.

© European Telecommunications Standards Institute 2000.  
All rights reserved.

# Contents

Intellectual Property Rights .....	11
Foreword .....	11
1 Scope .....	12
2 References .....	12
3 Definitions, symbols and abbreviations .....	13
3.1 Definitions .....	13
3.2 Symbols .....	14
3.3 Abbreviations .....	15
4 Description of services .....	17
4.1 Data services structure .....	17
4.2 Service objectives .....	18
4.3 Service definitions .....	18
4.3.1 PHL service definitions .....	19
4.3.2 MAC service definitions .....	19
4.3.3 DLC service definitions .....	20
4.3.4 NWK feature definitions .....	21
4.3.5 Application service definitions .....	23
4.3.6 Distributed Communication .....	23
5 PHL requirements .....	23
6 MAC layer requirements .....	23
6.1 MAC services .....	24
6.2 MAC service to procedure mapping .....	25
7 DLC-layer requirements .....	26
7.1 DLC services .....	26
7.2 DLC feature to procedure mapping .....	27
8 NWK layer requirements .....	28
8.1 NWK features .....	29
8.2 NWK feature to procedure mapping .....	30
8.3 Application features .....	32
8.4 Application feature to procedure mapping .....	33
8.5 Distributed Communications .....	33
9 Management Entity Requirements .....	34
9.1 Introduction .....	34
9.2 Description of the DPRS operation principles .....	34
9.2.1 General .....	34
9.2.2 Service class 1 .....	34
9.2.3 Service class 2 .....	34
9.3 Resource and physical connection management .....	35
9.3.1 Requirements applicable to the Fixed Part (FP) .....	35
9.3.1.1 Conditions for resumption and management procedures .....	35
9.3.1.1.1 General .....	35
9.3.1.1.2 ME procedures for FT initiated connection resumption .....	35
9.3.1.2 Connection Suspension conditions .....	36
9.3.1.2.1 General .....	36
9.3.1.2.2 Connection suspension due to no data activity .....	36
9.3.1.2.3 Connection suspension due to violation of the minimum number of bearers (MAC Bandwidth command) .....	36
9.3.1.2.4 Connection suspension by loss of all received bearers .....	36
9.3.1.3 Activation of Fast Scan mode after Connection suspension .....	37
9.3.1.4 Conditions for Bandwidth modification .....	37

9.3.1.4.1	General .....	37
9.3.2	Requirements applicable to the Portable Part (PP) .....	37
9.3.2.1	Conditions for connection resumption .....	37
9.3.2.1.1	Procedure for PT initiated Connection resumption. ....	37
9.3.2.1.2	"RFP-busy-for-data" flag .....	37
9.3.2.1.3	Waiting time for collision avoidance after deactivation of "RFP-busy-for-data" flag .....	38
9.3.2.1.4	Bandwidth after resumption.....	38
9.3.2.1.5	Resumption rejection by the FP .....	38
9.3.2.2	Conditions for Connection Suspension .....	38
9.3.2.2.1	General .....	38
9.3.2.2.2	Connection suspension due to no data activity .....	38
9.3.2.2.3	Connection suspension due to violation of the minimum number of bearers (MAC Bandwidth command) .....	38
9.3.2.2.4	Connection suspension by loss of all received bearers .....	39
9.3.2.2.5	Activation of fast scan mode after Connection suspension.....	39
9.3.2.3	Conditions for Bandwidth modification .....	39
9.3.2.3.1	General .....	39
9.4	Logical Connection management .....	39
9.4.1	Requirements for class 1 devices .....	39
9.4.2	Requirements for class 2 devices .....	39
9.4.2.1	General Description .....	39
9.4.2.2	Normal procedures of virtual call set-up and release .....	40
9.4.2.3	Abnormal release of Virtual Calls .....	40
9.4.2.4	Release of Logical Connection.....	40
9.4.2.5	The handshake (stay alive) procedure .....	40
10	MAC layer procedures .....	41
10.1	General .....	41
10.1.1	Frame and multiframe structure .....	41
10.1.2	Bit mappings .....	41
10.1.3	Time multiplexers .....	41
10.1.5	Scrambling .....	41
10.1.6	Error control .....	41
10.1.7	A-tail identifications .....	41
10.1.8	B-field identifications .....	41
10.1.9	RFP idle receiver scan sequence.....	41
10.1.10	PT receiver scan sequence .....	41
10.1.11	PP states and state transitions .....	41
10.1.12	Identities .....	42
10.2	Non continuous broadcast .....	42
10.2.1	Request for specific Q-channel information .....	42
10.2.2	Request for a new dummy.....	42
10.3	Downlink broadcast.....	42
10.3.1	$Q_T$ messages .....	42
10.3.2	$Q_T$ messages .....	43
10.3.2.1	$Q_T$ - static system information .....	43
10.3.2.2	$Q_T$ - FP capabilities .....	44
10.3.2.2.1	Standard FP Capabilities .....	44
10.3.2.2.2	Extended FP Capabilities.....	44
10.3.2.3	Multiframe number.....	45
10.3.2.4	$Q_T$ - SARI list contents .....	45
10.4	Paging broadcast .....	46
10.4.1	Paging message formats.....	46
10.4.1.1	Long or full page message format .....	46
10.4.1.2	short page message format .....	47
10.4.1.3	Zero length page message format .....	47
10.4.1.4	MAC resume page message format.....	48
10.4.2	MAC layer information in zero and short length paging messages.....	48
10.4.3	FP paging procedure .....	48

10.4.4	PP paging procedure (Detection of paging message in idle locked mode)	48
10.5	Logical Connection Setup	49
10.6	Logical Connection Release	49
10.7	Connection Modification	49
10.7.1	Bandwidth negotiation	49
10.7.2	Bandwidth modification	51
10.7.3	Suspend	51
10.7.4	Resume	51
10.8	Physical Connection Setup	51
10.8.1	Single bearer physical connection setup	51
10.8.2	Multibearer Physical Connection setup	52
10.9	Physical Connection Release	52
10.10	Bearer Setup	52
10.10.1	Single duplex bearer setup	52
10.10.1.1	PT initiated Single duplex bearer setup	53
10.10.1.2	FT initiated Single duplex bearer setup	53
10.10.1.3	Usage of channel list messages for single duplex bearer setup	54
10.10.2	Double simplex bearer setup	54
10.11	Bearer Release	55
10.11.1	Unacknowledged release	55
10.11.2	Acknowledged release	56
10.11.3	Fast release	56
10.12	Advanced connection handover	56
10.13	I-channel operation	57
10.13.1	I <sub>p</sub> -error-detect mode	57
10.13.2	I <sub>p</sub> -error-correct mode	57
10.13.2.1	Unilateral jump	57
10.13.2.2	Bearer reset	57
10.13.3	Connectionless SI <sub>p</sub> mode	57
10.14	C-channel operation	58
10.14.1	C <sub>S</sub> -channel	58
10.14.2	C <sub>F</sub> -channel	58
10.15	Encryption	58
10.15.1	Encryption process - initialization and synchronization	58
10.15.2	Encryption mode control	58
10.15.2.1	M <sub>T</sub> message	58
10.15.2.2	PT procedure for enabling encryption	58
10.15.2.3	PT procedure for disabling encryption	59
10.15.3	Handover encryption process	59
10.16	Quality control	59
10.16.1	RFPI handshake	59
10.16.2	PT frequency correction	59
10.16.3	Bearer quality report	59
10.16.4	Bearer and connection control	60
10.16.5	A-CRC handshake	60
10.17	Physical channel selection	60
10.18	Bearer replacement	60
10.19	Bearer handover request	61
10.20	G <sub>F</sub> -channel	61
10.20.1	G <sub>F</sub> -channel data	61
11	DLC layer procedures	61
11.1	LU10 Enhanced Frame RELay service (EFREL)	61
11.1.1	Window size	61
11.1.2	U-plane transmission class 2	62
11.1.2.1	Sending side procedures	62
11.1.2.2	Receiving side procedure	62
11.2	FU 10 framing (FU10a, FU10b, FU10c)	62
11.2.1	FU10a	62
11.2.2	FU10b	62
11.2.3	FU10c	63

11.3	Class A operation .....	63
11.3.1	Class A link establishment .....	63
11.3.1.1	Lower Layer Management Entity (LLME) establishment of a MAC connection.....	63
11.3.2	Class A acknowledged information transfer .....	65
11.3.3	Class A link release.....	65
11.3.4	Class A link re-establishment.....	65
11.4	Class U operation .....	65
11.4.1	Class U use of LLN for unacknowledged information transfer.....	65
11.4.2	Class U link establishment.....	65
11.4.3	Class U unacknowledged information transfer .....	66
11.4.4	Class U unacknowledged release .....	66
11.5	Lc frame delimiting and sequencing service.....	66
11.5.1	C <sub>S</sub> -channel fragmentation and recombination .....	66
11.5.2	C <sub>F</sub> -channel fragmentation and recombination .....	66
11.5.3	Selection of logical channels (C <sub>S</sub> and C <sub>F</sub> ) .....	66
11.6	Broadcast Lb service .....	66
11.6.1	Normal broadcast.....	66
11.6.2	Expedited broadcast.....	68
11.7	Connection handover.....	68
11.7.1	Class A connection handover.....	68
11.7.1.1	Voluntary handover.....	69
11.7.1.2	Associated procedure .....	69
11.7.1.2.1	LLME connection handover management .....	69
11.7.1.3	Exceptional case.....	69
11.7.1.3.1	Receipt of a request for link release.....	69
11.8	Connection modification .....	69
11.9	Encryption switching .....	71
11.9.1	Associated procedure.....	71
11.9.1.1	Providing Encryption key to the MAC layer .....	71
11.9.2	Exceptional cases.....	71
11.9.2.1	Encryption fails .....	71
11.9.2.2	Connection handover of ciphered connections.....	71
12	NWK layer procedures.....	72
12.1	Outgoing call request.....	72
12.2	Incoming call request .....	72
12.3	Terminal capability indication.....	73
12.4	Internal call keypad .....	73
12.5	Call Resources/Parameters negotiation .....	73
12.5.1	Default values .....	79
12.6	Bandwidth Change .....	81
12.6.1	Associated procedures .....	82
12.6.1.1	Timer F/P <CC_service> management .....	82
12.6.2	Exceptional cases.....	82
12.6.2.1	Service change request is rejected.....	82
12.6.3	Examples.....	83
12.7	Connection Reversal.....	83
12.8	IWU-attributes change.....	84
12.9	Dynamic Parameters Allocation .....	85
12.10	Cipher-switching initiated by PT .....	90
12.11	Temporary Identity Assign .....	90
12.11.1	Associated procedures .....	91
12.11.1.1	Timer F-<MM_ident.1> management.....	91
12.11.2	Exceptional cases.....	91
12.11.2.1	PT rejects the identity assignment.....	91
12.12	Indirect FT initiated link establishment .....	92
12.13	Fast paging .....	92
12.14	Collective and Group Ringing .....	93
12.15	Direct FT initiated link establishment .....	93
12.15.1	Exceptional case .....	94
12.15.1.1	Link establishment failure .....	94

12.16	Resume Paging .....	94
12.17	Broadcast attributes management .....	95
12.18	U-plane handling .....	96
12.19	Management of MM procedures .....	97

## **Annex A (normative):      Operating parameters .....98**

A.1	ME operating parameters .....	98
A.1.1	Constants (applicable to class 1 and class 2 devices) .....	98
A.1.2	Equations .....	98
A.1.2.1	Waiting time for collision avoidance (WtA) .....	98
A.1.2.1.1	Description .....	98
A.1.2.1.2	Formula .....	98
A.1.2.2	Waiting time for congestion avoidance (WtB) .....	98
A.1.2.2.1	Description .....	99
A.1.2.2.2	Formula .....	99
A.1.3	Variable parameters (class 2 systems only) .....	99
A.1.3.1	Parameters set by the FP (class 2 systems only) .....	99
A.1.3.2	Negotiable parameters between FP and PP (class 2 systems only) .....	100
A.1.3.2.1	Conditions of negotiation .....	100
A.2	Configuration capabilities for class 1 devices .....	100

## **Annex B (normative):      Interworking conventions for the Frame Relay (FREL) service .....101**

B.1	Scope of this annex .....	101
B.1.1	Typical configuration for the Frame Relay Service .....	101
B.2	Specific codings for mobility class 2 .....	102
B.2.1	IWU-Attribute coding .....	102
B.2.1.1	Profile subtype byte (byte 6) of <<IWU-attributes>> .....	103
B.2.1.1.1	ISO 8802-3 (Ethernet) .....	103
B.2.1.1.2	ISO 8802-5 (Token-Ring) .....	103
B.2.1.1.3	Internet Protocol .....	103
B.2.2	IWU attributes implemented .....	104
B.3	Generic Frame Relay service interworking conventions .....	104
B.3.1	DLC U-plane service .....	104
B.3.2	SDU checksum .....	104
B.3.3	Transmission bit order .....	104
B.3.4	Support of SDU size .....	104
B.3.5	SI <sub>p</sub> connectionless downlink .....	105
B.4	ISO 8802-3 (Ethernet) .....	105
B.4.1	Typical configuration .....	105
B.4.1.1	Examples of implementation of the external transport network .....	105
B.4.2	Specific interworking conventions .....	105
B.4.2.1	Use of the connectionless downlink SI <sub>p</sub> service .....	106
B.4.2.2	Special conventions for mobility class 1 systems .....	106
B.5	IEE 802-5 (Token Ring) .....	106
B.5.1	Typical configuration .....	106
B.5.1.1	Examples of implementation of the external transport network .....	106
B.5.2	Specific interworking conventions .....	107
B.5.2.1	Special conventions for mobility class 1 systems .....	107
B.5.2.2	Use of the connectionless downlink SI <sub>p</sub> service .....	107
B.6	Internet protocol .....	108
B.6.1	Typical configuration .....	108
B.6.1.1	Examples of implementation of the external transport network .....	108
B.6.2	Specific interworking conventions .....	108
B.6.2.1	Special conventions for mobility class 1 systems .....	108

B.7	Point-to-Point Protocol.....	109
B.7.1	Typical configuration .....	109
B.7.1.1	Examples of implementation of the external transport network.....	109
B.7.2	Specific interworking conventions .....	109
B.7.2.1	Special conventions for mobility class 1 systems .....	109
<b>Annex C (normative): Interworking conventions character-oriented services.....</b>		<b>110</b>
C.1	Scope of this annex .....	110
C.1.1	Scenario A .....	111
C.1.2	Scenario B .....	112
C.2	Specific coding for mobility class 2.....	112
C.2.1	IWU-Attribute coding .....	112
C.2.2	Default-values.....	115
C.2.3	Negotiation of the V.24-parameters .....	115
C.3	Generic interworking conventions .....	115
C.3.1	PAD functionality.....	115
C.3.1.1	Character formatting .....	116
C.3.2	Support of SDU size.....	116
C.4	V.24 circuits .....	117
C.4.1	General .....	117
C.4.2	Encapsulation .....	117
C.4.2.1	Description.....	117
C.4.2.2	Framing.....	117
C.4.2.3	Coding of encapsulation .....	117
C.4.2.3.1	DCE-emulation side interpretation.....	118
C.4.2.3.2	DTE-emulation side interpretation.....	118
C.4.2.4	SDU Structure.....	119
C.4.3	Interworking procedures and conventions .....	120
C.4.3.1	General.....	120
C.4.3.1.1	Data forwarding conditions .....	120
C.4.3.1.2	Dataflow Control.....	120
C.4.3.1.2.1	Software dataflow control.....	120
C.4.3.1.2.2	Hardware dataflow control .....	120
C.4.3.1.3	Transmission of U-plane data procedure.....	120
C.4.3.1.4	Receive of U-plane data procedure .....	120
C.4.3.1.5	V.24 signalling .....	121
C.4.3.1.6	Configuration a V.24 interface during a Connection.....	121
C.4.3.2	Fall back procedure.....	121
C.4.3.3	Procedure at the DCE-emulation side IWU .....	121
C.4.3.3.1	DTE- initiated VC establishment .....	121
C.4.3.3.2	DCE-initiated VC establishment .....	121
C.4.3.3.3	V.24 call release .....	122
C.4.3.4	Procedure at the DTE-emulation side IWU .....	122
C.4.3.4.1	DCE-initiated VC establishment .....	122
C.4.3.4.2	DTE-initiated VC establishment .....	122
C.4.3.4.3	V.24 call release.....	122
C.5	Definition of User Control Information Elements .....	123
C.5.1	Mandatory UIEs .....	123
C.5.2	Optional UIEs.....	123
C.5.3	Information Element Identifier .....	123
<b>Annex D (normative): Amendments to EN 300 175.....</b>		<b>124</b>
D.1	Amendments to EN 300 175-3.....	124
D.1.2	MAC resume page message.....	124
D.1.2.1	MAC page message (add to subclause 7.2.4.1 of EN 300 175-3).....	124
D.1.2.1.1	P <sub>T</sub> format for MAC_resume page message (7.2.4.1.4).....	124



D.1.2.1.2	B <sub>S</sub> SDU length indication (7.2.4.2.3) .....	124
D.1.3	Bearer and connection control (7.3.4.2) .....	125
D.1.4	Unilateral jump procedure .....	125
D.1.4.1	Bearer quality in an asymmetric connection (7.3.4.4).....	125
D.1.4.2	General (10.6.1).....	126
D.1.4.3	Q2 bit settings (10.8.1.3.1) .....	127
D.1.4.4	MOD-2 protected I-channel operation (I <sub>p</sub> ) (10.8.2).....	128
D.1.4.4.1	General (10.8.2.1) .....	128
D.1.4.4.2	Use of the acknowledge bits (10.8.2.4).....	128
D.1.4.4.3	Q2 bit setting for I <sub>p_error_correction</sub> services (10.8.2.4.1) .....	128
D.1.4.4.4	Unilateral jump (10.8.2.5.2).....	129
D.1.5	Bearer Replacement .....	130
D.1.6	Extended FP capabilities .....	131
D.2	Amendments to EN 300 175-4.....	131
D.2.1	FU-10 frame structure .....	131
D.2.2	Length indicator elements.....	132
D.2.3	Sequence number elements.....	134
D.2.4	Class 2: variable throughput, maximum delay LUX retransmission.....	135
D.2.5	Class 2 procedures.....	135
D.2.6	LU10 Enhanced Frame RELay (EFREL) Service .....	138
D.3	Amendments to EN 300175-5.....	140
D.3.1	Changes to subclause 7.7.43.....	140
D.3.2	Changes to subclause 7.7.41.....	141
D.3.3	Changes to subclause 7.7.21.....	141
D.3.4	Changes to subclause 7.7.5.....	142
D.3.5	Changes to subclause A.1.....	142
D.3.6	Changes to subclause 6.3.6.1.....	142
D.3.7	Changes to subclause 6.3.6.17.....	143
D.3.8	Changes to subclause 6.3.6.22.....	144
D.3.9	Changes to subclause 7.7.40.....	144
D.3.10	Changes to subclause 6.3.....	145
D.3.11	Changes to subclause 8.3.....	145
D.3.12	Changes to subclause 7.7.20.....	146
D.3.13	Changes to subclause 8.2.1.....	147
D.3.14	Changes to subclause 8.2.2.....	147
D.3.15	Add subclause 14.5.....	148
D.3.16	Add Distributed Communication changes to Base standard.....	148
D.3.17	U-plane frame type .....	148

## **Annex E (normative): Distributed Communication Specification Protocol Requirements .....149**

E.1	Definitions and Abbreviations .....	149
E.1.1	Definitions .....	149
E.1.2	Abbreviations .....	149
E.2	General Requirements .....	150
E.2.1	DCDL-net.....	150
E.2.2	Subscription.....	150
E.2.3	Communication .....	151
E.3	Procedure description.....	151
E.3.1	HyP Identities .....	151
E.3.2	Membership Access Rights Allocation.....	151
E.3.3	Re-initialization of membership access rights .....	152
E.3.4	Members Data Transfer .....	152
E.3.5	Presence/Absence Indication.....	154
E.3.6	Bandwidth management .....	154
E.3.7	Direct Link Establishment .....	155
E.3.8	Indirect Link Establishment.....	156
E.3.9	MASTER management.....	157

E.3.9.1	MASTER assign .....	157
E.3.9.2	MASTER Change .....	157
E.3.9.3	DCDL-net System bearer management .....	157
E.3.10	Common Subscription Database management .....	158
E.3.10.1	IdN .....	158
E.3.10.2	RFPI, PARK and PLI .....	158
E.3.10.3	IPUI .....	159
E.3.10.4	TPUI and LAL .....	159
E.3.10.5	Keys .....	159
E.3.11	Handover issues .....	159
E.4	Elements of Messages/Information Elements .....	160
E.4.1	CLMS-FIXED .....	160
E.4.2	IWU-TO-IWU .....	161
E.4.3	Info-type .....	162
E.4.4	CLMS-VARIABLE .....	162
E.5	Examples .....	162
E.5.1	General .....	162
E.5.2	Example 1 .....	163
E.5.3	Example 2 .....	163
E.5.4	Example 3 .....	164
E.5.5	Example 4 .....	165
E.6	Usage of PPs or FPs in DCDL-net .....	167
E.6.1	General .....	167
E.6.2	Requirements to FPs .....	167
E.6.2.1	General .....	167
E.6.2.2	Members Data Transfer .....	167
E.6.2.3	Direct Link Establishment .....	168
E.6.3	Requirements to PPs .....	168
E.6.3.1	General .....	168
E.6.3.2	Membership Access Rights Allocation .....	168
E.6.3.3	Members Data Transfer .....	169
E.6.3.4	Direct Link Establishment .....	169
E.6.3.5	Indirect Link Establishment .....	169
E.6.4	Handling of PP and FP by a HyP .....	169
History	.....	170

---

## Intellectual Property Rights

IPRs essential or potentially essential to the present document may have been declared to ETSI. The information pertaining to these essential IPRs, if any, is publicly available for **ETSI members and non-members**, and can be found in SR 000 314: "*Intellectual Property Rights (IPRs); Essential, or potentially Essential, IPRs notified to ETSI in respect of ETSI standards*", which is available from the ETSI Secretariat. Latest updates are available on the ETSI Web server (<http://www.etsi.org/ipr>).

Pursuant to the ETSI IPR Policy, no investigation, including IPR searches, has been carried out by ETSI. No guarantee can be given as to the existence of other IPRs not referenced in SR 000 314 (or the updates on the ETSI Web server) which are, or may be, or may become, essential to the present document.

---

## Foreword

This European Standard (Telecommunications series) has been produced by ETSI Project Digital Enhanced Cordless Telecommunications (DECT).

<b>National transposition dates</b>	
Date of adoption of this EN:	14 January 2000
Date of latest announcement of this EN (doa):	30 April 2000
Date of latest publication of new National Standard or endorsement of this EN (dop/e):	31 October 2000
Date of withdrawal of any conflicting National Standard (dow):	31 October 2000

---

## 1 Scope

The present document defines the standard for packet radio services for Digital Enhanced Cordless Telecommunications (DECT) systems conforming to EN 300 175, Parts 1 to 7 [1] to [7]. It is the basis of profiles, which define more specific applications (Application Specific Access Profiles ASAPs), aimed at the connection of terminals supporting packet data services to a fixed infra-structure, both private and public.

The present document defines a basic service, with the service classes 1 or 2. Service class 1 provides for applications in closed user groups, whereas service class 2 is intended for use in private and public roaming applications.

Annexes to the present document contain the conventions for interworking of the frame-relay and character oriented services.

The present document defines the additional requirements on the Physical Layer (PHL), Medium Access Control (MAC) layer, Data Link Control (DLC) layer and Network (NWK) layer of DECT. The standard also specifies Management Entity (ME) requirements, which ensure the efficient use of the DECT spectrum.

---

## 2 References

The following documents contain provisions which, through reference in this text, constitute provisions of the present document.

- References are either specific (identified by date of publication, edition number, version number, etc.) or non-specific.
- For a specific reference, subsequent revisions do not apply.
- For a non-specific reference, the latest version applies.
- A non-specific reference to an ETS shall also be taken to refer to later versions published as an EN with the same number.

- [1] EN 300 175-1: "Digital Enhanced Cordless Telecommunications (DECT); Common Interface (CI); Part 1: Overview".
- [2] EN 300 175-2: "Digital Enhanced Cordless Telecommunications (DECT); Common Interface (CI); Part 2: Physical layer (PHL)".
- [3] EN 300 175-3: "Digital Enhanced Cordless Telecommunications (DECT); Common Interface (CI); Part 3: Medium Access Control (MAC) layer".
- [4] EN 300 175-4: "Digital Enhanced Cordless Telecommunications (DECT); Common Interface (CI); Part 4: Data Link Control (DLC) layer".
- [5] EN 300 175-5: "Digital Enhanced Cordless Telecommunications (DECT); Common Interface (CI); Part 5: Network (NWK) layer".
- [6] EN 300 175-6: "Digital Enhanced Cordless Telecommunications (DECT); Common Interface (CI); Part 6: Identities and addressing".
- [7] EN 300 175-7: "Digital Enhanced Cordless Telecommunications (DECT); Common Interface (CI); Part 7: Security features".
- [8] EN 300 444: "Digital Enhanced Cordless Telecommunications (DECT); Generic Access Profile (GAP)".
- [9] EN 300 824: "Digital Enhanced Cordless Telecommunications (DECT); Cordless Terminal Mobility (CTM); CTM Access Profile (CAP)".

- [10] EN 300 176-1: "Digital Enhanced Cordless Telecommunications (DECT); Approval test specification; Part 1: Radio".
- [11] ETR 043: "Digital Enhanced Cordless Telecommunications (DECT); Common Interface (CI); Services and facilities requirements specification".
- [12] ETS 300 476-2: "Digital Enhanced Cordless Telecommunications (DECT); Common Interface (CI); Protocol Implementation Conformance Statement (PICS) proforma; Part 2: Data Link Control (DLC) layer - Portable radio Termination (PT)".
- [13] ETS 300 476-3: "Digital Enhanced Cordless Telecommunications (DECT); Common Interface (CI); Protocol Implementation Conformance Statement (PICS) proforma; Part 3: Medium Access Control (MAC) layer - Portable radio Termination (PT)".
- [14] ETS 300 476-4: "Digital Enhanced Cordless Telecommunications (DECT); Common Interface (CI); Protocol Implementation Conformance Statement (PICS) proforma; Part 4: Network (NWK) layer - Fixed radio Termination (FT)".
- [15] ETS 300 476-5: "Digital Enhanced Cordless Telecommunications (DECT); Common Interface (CI); Protocol Implementation Conformance Statement (PICS) proforma; Part 5: Data Link Control (DLC) layer - Fixed radio Termination (FT)".
- [16] ISO/IEC 8802-3 (1996): "Information technology - Telecommunications and information exchange between systems - Local and metropolitan area networks - Specific requirements - Part 3: Carrier sense multiple access with collision detection (CSMA/CD) access method and physical layer specifications".
- [17] ISO/IEC 8802-5 (1998): "Information technology - Telecommunications and information exchange between systems - Local and Metropolitan Area Networks - Specific requirements - Part 5: Token ring access method and physical layer specifications".
- [18] RFC 791 (1981): "Internet Protocol", J. Postel.
- [19] RFC 1661 (1994): "The Point-to-Point Protocol (PPP)", W. Simpson, Editor.
- [20] RFC 1662 (1994): "PPP in HDLC-like Framing", W. Simpson, Editor.
- [21] CCITT Recommendation V.24 (1988): "List of definitions for interchange circuits between data terminal equipment (DTE) and data circuit-terminating equipment (DCE)".
- [22] ISO/IEC 9646-7: "Information technology - Open Systems Interconnection - Conformance testing methodology and framework - Part 7: Implementation Conformance Statements".

---

## 3 Definitions, symbols and abbreviations

### 3.1 Definitions

For the purposes of the present document, the following terms and definitions apply.

**Access Rights Identity (ARI):** see EN 300 175-6 [6]

**service class 1:** local area applications, for which terminals are pre-registered off-air with one or more specific Fixed Parts (FPs), and establishment of service and user parameters is therefore implicit, according to a profile-defined list

**service class 2:** private and public roaming applications for which terminals may move between FPs within a given domain and for which association of service parameters is explicit at the time of service request

**multiframe:** repeating sequence of 16 successive Time Division Multiple Access (TDMA) frames, that allows low rate or sporadic information to be multiplexed (e.g. basic system information or paging)

**TDMA frame:** time-division multiplex of 10 ms duration, containing 24 successive full slots. A TDMA frame starts with the first bit period of full slot 0 and ends with the last bit period of full slot 23

**Physical Connection:** association between two sets of TBC<sub>S</sub> at MAC layer including the underlying bearers that belong to a single Logical connection

**Logical connection:** association between two instances of the MAC MBC that can be used by higher layers to exchange U-plane or C-plane data

**Link:** association between two DLC layer entities. This can either be one DLC C-plane association or one DLC U-plane association. Usually, but not necessarily, one DLC Link is mapped to one Logical connection

**Virtual circuit:** in service class 2, a Virtual Circuit is any user connection opened at NWK layer. Virtual circuits could be of two types: Virtual Calls (VC) and Permanent Virtual Circuits (PVC). A Virtual circuit is mapped to one Link and to one MBC Logical connection

**Virtual Call (VC):** any packet-mode user connection that can be set up and released by means of NWK layer C-plane procedures. A Virtual Call is the packet-mode equivalent of a circuit-mode call. Virtual Calls can only be provided by DPRS service class 2

**Permanent Virtual Circuit (PVC):** Virtual Circuit that can be established and cleared only by configuration.

NOTE: A Permanent Virtual Circuit is the packet-mode equivalent of a circuit-mode leased line. A PVC can be provided by both DPRS mobility class 1 and 2. Service class 1 provides by construction a PVC between any pair of FP, PP. In service class 2, a PVC is a degenerated case of a VC.

**Suspended state:** state of an established Logical connection with no associated TBC's or physical layer resources

**Suspend:** procedure to release the Physical connection without releasing the Logical connection

**Resumed state:** state of an established Logical connection, open at MB, DLC and NWK, with active TBC's and physical layer

**Resume:** procedure to establish the Physical Connection related to a Suspended Logical connection

**Physical Connection release:** procedure to release all bearers and TBC's associated with a Logical connection. Physical Connection release is always under control of the Management Entity (ME)

**Physical Connection establishment:** procedure to activate all bearers and TBC's related to a single Logical connection. The Physical Connection establishment is always under control of the Management Entity (ME)

**Logical connection establishment:** in service class 2, the procedure to create a logical connection. The Logical connection establishment is instanciated by the DLC upon request of the NWK layer

**Logical connection release:** in service class 2, the procedure to release a logical connection. The Logical connection release is usually instanciated by the DLC upon request of the NWK layer, but under certain circumstances it could also be initiated by the ME

## 3.2 Symbols

The symbols defined in this subclause are applied for procedures, features, and services in the present document if not explicitly otherwise stated. The interpretation of status columns in all tables is as follows:

- M for mandatory to support (provision mandatory, process mandatory);
- O for optional to support (provision optional, process mandatory);
- O.x option comprising number of items;
- I for out-of-scope (provision optional, process optional) not subject for testing;
- C for conditional to support (process mandatory);

N/A for not-applicable (in the given context the specification makes it impossible to use this capability);

X excluded, not allowed.

Provision mandatory, process mandatory means that the indicated feature service or procedure shall be implemented as described in the present document, and may be subject to testing.

Provision optional, process mandatory means that the indicated feature, service or procedure may be implemented, and if implemented, the feature, service or procedure shall be implemented as described in the present document, and may be subject to testing.

NOTE: The used notation is based on the notation proposed in ISO/IEC 9646-7 [22].

### 3.3 Abbreviations

For the purposes of the present document, the following abbreviations apply:

AC	Authentication Code
ACK	Acknowledgement
AMCI	Advanced MAC Connection Identifier
ARI	Access Rights Identity
ARQ	Automatic Retransmission reQuest
BMC	Broadcast Message Controller
BPAD	Bit oriented Packet Assembler/Disassembler
C	higher layer control Channel (see C <sub>S</sub> and C <sub>F</sub> )
C/L	ConnectionLess
C/O	Connection Oriented
CC	Call Control. A NWK layer functional grouping
C <sub>F</sub>	higher layer signalling Channel (Fast)
CNO	ConnectioN Handover
C-plane	Control plane
CRC	Cyclic Redundancy Check
C <sub>S</sub>	higher layer signalling Channel (Slow)
CSMA/CD	Carrier Sense Multiple Access with Collision Detection
CUG	Closed User Group
DCE	Data Circuit terminating Equipment
DECT	Digital Enhanced Cordless Telecommunications
DLC	Data Link Control
DTE	Data Terminal Equipment
ECN	Exchanged Connection Number
EDEL	End DELimiter
FC	Frame Control
FCS	Frame Check Sequence
FP	Fixed Part
FREL	Frame Relay
FS	Frame Status
FT	Fixed radio Termination
GAP	Generic Access Profile
GSM	Global System for Mobile communication
HDLC	High level Data Link Control
I	higher layer Information channel (see I <sub>N</sub> and I <sub>P</sub> )
I <sub>N</sub>	higher layer Information channel (unprotected)
I <sub>P</sub>	higher layer Information channel (protected)
IP	Internet Protocol
IPUI	International Portable User Identity
ISDN	Integrated Services Digital Network
IWF	Interworking Functions
IWU	InterWorking Unit
L	Length

LA	Location Area
LAN	Local Area Network
LAP-B	Link Access Procedure (Balanced)
LAP-C	Link Access Procedure (Control)
LAP-U	Link Access Procedure (U-plane)
LBN	Logical Bearer Number
LCE	Link Control Entity
L <sub>1</sub>	Length Indicator
LLME	Lower Layer Management Entity
LSB	Least Significant Bit
M	MAC control channel
MAC	Medium Access Control
MBC	Multi Bearer Control
MCI	MAC Connection Identifier
ME	Management Entity
MM	Mobility Management
MSB	Most Significant Bit
MUX	time MULTipleXors
N	identities channel
NLF	New Link Flag
NWK	Network
OAM	Operation And Maintenance
P	Paging channel
PAD	Packet Assembler-Disassembler
PARI	Primary Access Rights Identity
PDU	Protocol Data Unit
PHL	PHYSical Layer
PHY	PHYSical
PICS	Protocol Implementation Conformance Statement
PMID	Portable part MAC IDentity
PP	Portable Part
PPP	Point-to-Point Protocol
PT	Portable radio Termination
PVC	Permanent Virtual Circuit
Q	system information channel
RFP	Radio Fixed Part
RFPI	Radio Fixed Part Identity
SAP	Service Access Point
SAPI	Service Access Point Identifier
SARI	Secondary Access Rights Identity
SDEL	Start DELimiter
SDU	Service Data Unit
SFD	Start Frame Delimiter
SI <sub>p</sub>	Higher layer connectionless channel (protected)
TAF	Terminal Adaptation Function
TARI	Tertiary Access Rights Identity
TBC	Traffic Bearer Control
TDMA	Time Division Multiple Access
TPUI	Temporary Portable User Identity
U-plane	User-plane



## 4 Description of services

### 4.1 Data services structure

The DPRS standard defines the way to implement packet-data services on a DECT network. DPRS mandates a set of minimum requirements to be supported, and some additional options, which may be either configured for service class 1, or negotiated at call setup for service class 2 equipment.

The DPRS standard forms the core for DECT packet data applications; it may either be used as a basis for other data profiles, or for direct interworking to other networks. The application service type determines which of the interworking functions has to be selected (from annexes B and C). The application service requirements determine whether a C-plane is needed or not.

The relation between DPRS entities is shown in figure 1.

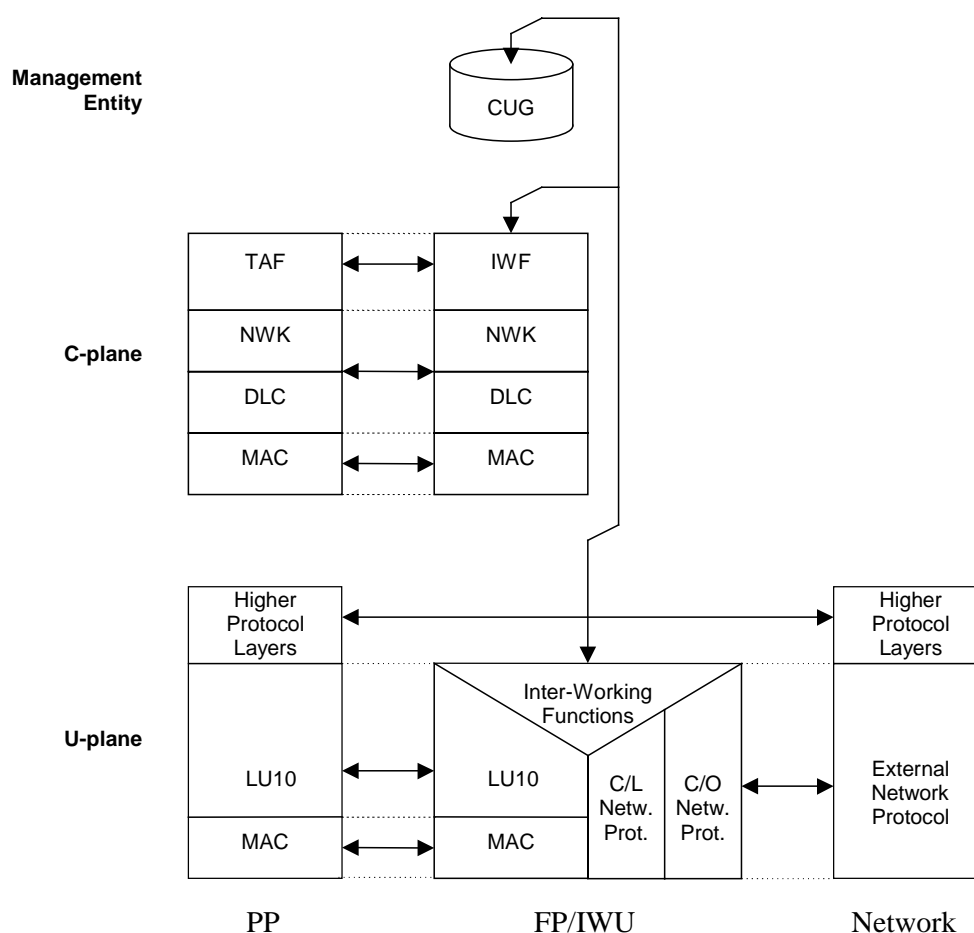

**Figure 1: Reference configuration for DPRS profiles**

DPRS offers to the user a maximum delay frame relay or streamed data service, incorporating procedures for flow control (path by path, using bandwidth control) and automatic retransmission (DLC transmission class 2).

Additional requirements for interworking to external frame relay networks are defined in annex B.

Additional requirements for interworking to external stream-oriented networks are defined in annex C.

Service class 1 excludes call-setup procedures, and therefore in this case the virtual circuit is implicitly and permanently present. These applications are intended for Closed User Groups (CUG). This means that PPs are statically registered within the FP, and service parameters are configured as defined in annex A.

The service offered is analogous to a permanent virtual circuit (PVC), i.e. DECT is required to provide an appropriate bearer between the PT terminal adapter function (TAF) and the FT Interworking unit (IWU), where Interworking is performed with a network that is either connectionless or uses application-based in-band signalling for connection control.

Service class 2 offers a full DECT C-plane, including call-setup procedures, service management and service negotiation. In this case the virtual circuit is only present within the context of a call. The applications are intended for private and public roaming, and service parameters are negotiated during the call-setup phase, and may be changed during the active phase of the call.

For all resulting profiles specific interworking conventions determine the interaction between DECT C-plane and U-plane on one side, and the external network protocol on the other side.

## 4.2 Service objectives

The DPRS has the performance and service objectives given in the following tables.

**Table 1: Performance objectives**

Performance	
Maximum supported SDU size for Frame Relay services (annex B)	≥ 1528 octets
Maximum supported SDU size for character oriented services (annex C)	≥ 29 octets
Maximum one-way delay	Down to 50ms configurable
Maximum sustainable unidirectional throughput (per transceiver)	24 kbit/s-552 kbit/s net
Maximum sustainable full bi-directional throughput (per transceiver)	24 kbit/s-288 kbit/s net
Establishment of PT to FT physical connection (average)	< 50 ms
Establishment of FT to PT physical connection (average)	< 50 ms
Undetected bit error ratio	< 10 <sup>-10</sup>
Uncorrected bit error ratio (for air interface BER 10 <sup>-3</sup> , and delay = 100 ms)	< 10 <sup>-7</sup>

**Table 2: Summary of service capabilities**

Service	Class 1	Class 2
Point-to-point protected data transfer PP-FP with ARQ	YES	YES
Point-to-point protected data transfer FP-PP with ARQ	YES	YES
Point-to-multi-point data transfer FP-PP	OPTIONAL	OPTIONAL
Point-to-point data transfer PP-PP (distributed communication)	OPTIONAL	OPTIONAL
Authentication	-	YES
Encryption	YES	YES
Permanent Virtual Circuit (PVC) operation	YES	YES
Virtual Call (VC) operation	-	YES
Intra-cell bearer handover (see note)	YES	YES
Inter-cell bearer handover (see note)	-	YES
Inter-cell connection handover (for multicell systems)	-	YES
Inter-cell external handover	-	OPTIONAL
NOTE: Bearer handover capability may be provided by the bearer replacement procedure.		

## 4.3 Service definitions

For the purposes of the present document the following service definitions apply.

### 4.3.1 PHL service definitions

See PHL requirements in clause 5.

### 4.3.2 MAC service definitions

**general [DPRS-M.1]:** a set of basic requirements regarding data formats, multiplexing, CRC usage, scanning and locking, which are prerequisites to communication between peer MAC entities.

**non continuous broadcast [DPRS-M.2]:** a simplex service from FT to PT which allow PTs to acquire more Q-channel information (i.e. TARI) and to request a new dummy bearer.

**continuous broadcast [DPRS-M.3]:** a simplex service from FT to PT whereby the FT maintains at least one bearer with continuous transmissions. The PT can use the information carried in this bearer to lock to the FT and to obtain knowledge about the FT. (GAP-M.2)

**paging broadcast [DPRS-M.4]:** a service whereby the identities of specific PTs can be broadcast by the FT. This service is normally used by the FT to request a specific PT to set up a link to the FT. (GAP-M.3)

**advanced connection [DPRS-M.5]:** a service providing connection between FT and PT consisting of one or more duplex and zero or more double simplex bearers. Advanced connections have a common connection number, called Exchanged Connection Number (ECN) which is assigned by the ME. Therefore, more than one advanced connection may exist between a PT and one FT. The service includes the means for setting-up and releasing the required bearer(s).

**Ip\_error\_detection service [DPRS-M.6]:** the I<sub>P</sub> information is protected by DLC layer retransmission procedures based on error detection by means of the B-subfield CRC's. The DLC layer takes care of packet lifetime control.

**Ip\_error\_correction service [DPRS-M.7]:** the I<sub>P</sub> information is protected by MAC layer procedures based on a modulo 2 retransmission scheme. The DLC layer requests the maximum allowed transmission time. Due to the retransmission mechanism, the effective throughput is variable.

**U-plane point-to-multipoint service [DPRS-M.8]:** a simplex service from FT to PT whereby the FT transfers a single SDU of U-plane data from one source point to one (or more) destination points. The service uses the SI<sub>P</sub> logical channel: the SI<sub>P</sub> information is protected by MAC layer error detection procedure based on 16 bit CRC<sub>S</sub>.

**C<sub>S</sub> higher layer signalling [DPRS-M.9]:** a low rate connection oriented data service with ARQ using the C<sub>S</sub>-channel to transfer higher layer signalling data. (GAP-M.5)

**C<sub>F</sub> higher layer signalling [DPRS-M.10]:** a high rate connection oriented data service with ARQ using the C<sub>F</sub>-channel to transfer higher layer signalling data.

**encryption activation [DPRS-M.11]:** a service providing means for enabling the encryption whereby on demand all higher layer data is transferred across the DECT air interface in an encrypted form. Always initiated by the PT. A connection release automatically disables ciphering. (GAP-M.7)

**encryption deactivation [DPRS-M.12]:** a service providing means for disabling the encryption whereby on demand all higher layer data is transferred across the DECT air interface in an encrypted form. A connection release automatically disables ciphering. (GAP-M.14)

**quality control [DPRS-M.13]:** provides means for monitoring and controlling the radio link quality. (GAP-M.6)

**physical channel selection [DPRS-M.14]:** defines the policy for the dynamic selection of a channel, caused by the fact that an old one has to be changed or a new one is needed. Detection of bad quality on the physical channel in use (i.e. due to weak signals or interference), detection of a RFP with a stronger signal than the one of the own RFP, detection of local congestion are all criteria that can be used to select the channel.

**Secondary Access Rights Identity (SARI) support [DPRS-M.15]:** the ability to support, in addition to the primary Access Rights Identity (ARI), secondary ARIs that the FT broadcasts less frequently than PARIs. These may be used to reflect an inter-operators agreement allowing a portable to access more than one operator or services through FT. (GAP-M.13)

**Bearer replacement [DPRS-M.16]:** bearer quality maintenance by setting up a replacement bearer in the same cluster, with different LBN and without the requirement of maintaining identical data on both bearers. Subsequently the old bearer is released; for efficiency, the sequence of setup and release may be reversed.

**Bearer handover [DPRS-M.17]:** bearer quality maintenance by setting up a replacement bearer in the same cluster, with identical LBN and maintaining identical data on both bearers. Subsequently the old bearer is released.

**Connection handover [DPRS-M.18]:** connection quality maintenance by setting up replacement bearers in the same or a different cluster, each with identical LBN and maintaining identical data bearers with identical LBN. Subsequently the old bearers are released.

**G<sub>F</sub>-channel [DPRS-M.19]:** the G<sub>F</sub>-channel is a fast simplex channel that is used to provide control of U-plane entities. For example it is used to carry acknowledgements for asymmetric connections.

### 4.3.3 DLC service definitions

**LU10 Enhanced Frame RELay service (EFREL) [DPRS-D.1]:** an enhanced frame relay service accessed through the LU10 SAP. The LU10 shall operate on a generic field of user data that shall be transferred into and out of the DLC U-plane as a single SDU. This SDU is assumed to contain one external frame, but the operation of LU10 shall be independent of the actual contents of the SDU. LU10 shall provide mechanisms that offer reliable transport of the generic SDUs, and that preserve the SDU boundaries.

**FU10a [DPRS-D.2]:** offers a defined fixed length frame structure and buffering functions for transmission of U-plane data to the MAC layer (at the transmit side) or accepts data from the MAC layer (at the receiving side) on demand and with minimum delay. Frame type FU10a is used for the forward path of unidirectional links.

**FU10b [DPRS-D.3]:** offers a defined fixed length frame structure and buffering functions for transmission of higher layer U-plane control data from the DLC to the MAC layer (at the transmit side) or accepts data from the MAC layer (at the receiving side) on demand and with minimum delay. Only be used for symmetrical connections using bi-directional links.

**FU10c [DPRS-D.4]:** offers a defined fixed length frame structure and buffering functions for transmission of higher layer U-plane control data from the DLC to the MAC layer (at the transmit side) or accepts data from the MAC layer (at the receiving side) on demand and with minimum delay. Used to carry acknowledgements or negative acknowledgement for connections. Frame type FU10c is used for the backward control path of unidirectional links: it contains a list of receive sequence numbers for the forward link.

**Data Link Service (LAPC+Lc) class A service [DPRS-D.5]:** a single frame acknowledged C-plane data link service providing a data link between one FT and one PT. The higher layer information is segmented (if necessary) and transmitted in numbered frames. The Lc service, upon which LAPC is defined, provides frame delimiting, transparency and frame synchronization. (GAP-D.1)

**Data Link Service (LAPC+Lc) class U service [DPRS-D.6]:** an unacknowledged C-plane data link service providing a data link between one FT and one or more PTs. The higher layer information is segmented (if necessary) and transmitted in unnumbered frames. The Lc service, upon which LAPC is defined, provides frame delimiting, transparency and frame synchronization, but no error recovery is defined.

**Lc Service [DPRS-D.7]:** a service providing channel dependant fragmentation, recombination, frame synchronization and frame delimiting transparency. Fragmentation is obtained by means of dividing a LAPC data unit into more than one service data units for delivery to the MAC layer C logical channel, whilst recombination is obtained by means of joining several service units received from the MAC layer C logical channel into a LAPC data unit. Allows the LLME to select the logical channel for Lc operation on a frame-by-frame basis.

**broadcast Lb service [DPRS-D.8]:** a simplex point-to-multipoint transmission using simple fixed length DLC frames providing a restricted broadcast service in direction FP to PP(s). (GAP-D.3)

**intercell voluntary connection handover [DPRS-D.9]:** internal handover process provided and initiated by the DLC layer (as a result of a particular policy, implementers dependent, application on link management. E.g. continued poor quality of service from the MAC layer), whereby one set of DLC entities (C-plane and U-plane) can re-route data from one MAC connection to a second new MAC connection not in the domain of the same cell, while maintaining the service provided to the NWK layer. (GAP-D.5)

**connection modification [DPRS-D.10]:** service that allows the DLC to modify a connection with connection type "Unknown".

**encryption activation [DPRS-D.11]:** transporting the NWK layer encryption request and the cipher key to the MAC layer, thereby enabling the encryption process in the MAC layer. (GAP-D.6)

**encryption deactivation [DPRS-D.12]:** transporting the NWK layer encryption deactivation request to the MAC layer, thereby disabling the encryption process in the MAC layer. (GAP-D.9)

#### 4.3.4 NWK feature definitions

**outgoing call [DPRS-N.1]:** a call initiated at a DECT PP. (GAP-N.1)

**off-hook [DPRS-N.2]:** the ability to indicate the action of going off-hook, e.g. to start call set-up or accept a call. (GAP-N.2)

**on-hook (FULL Release) [DPRS-N.3]:** the ability to indicate the action of going on-hook (e.g. to terminate a call) and fully release the radio resource. (GAP-N.3)

**dialled digits (basic) [DPRS-N.4]:** the capability to dial digits 0-9, \*, #. (GAP-N.4)

**register recall [DPRS-N.5]:** The ability of the PP to request the invocation of the supplementary service "register recall" over the DECT interface and the ability of the FP to transmit the request to the local network. Register recall means to seize a register (with dial tone) to permit input of further digits or other action. (GAP-N.5)

**go to DTMF signalling (defined tone length) [DPRS-N.6]:** go to DTMF signalling with defined tone length. (GAP-N.6)

**pause (dialling pause) [DPRS-N.7]:** the ability to generate or indicate an dialling pause, e.g. to await further dial tone. (GAP-N.7)

**incoming call [DPRS-N.8]:** a call received at a DECT PP. (GAP-N.8)

**authentication of PP [DPRS-N.9]:** the process by which the identity of a DECT PP is checked by the FP. (GAP-N.9)

**authentication of user [DPRS-N.10]:** the process by which the identity of a user of a DECT PP is checked by the FP. The User Personal Identification (UPI), a personal identification of 0 to 8 digits, manually entered by the user, is used for user authentication. (GAP-N.10)

**location registration [DPRS-N.11]:** a facility whereby a PP can be registered with a FP or a cluster of FPs such that incoming calls, radio pages or messages may be routed to it. (GAP-N.11)

**on-air key allocation [DPRS-N.12]:** the capability to transform Authentication Code (AC) into User Authentication Key (UAK) using the key allocation procedure. (GAP-N.12)

**identification of PP [DPRS-N.13]:** the ability for the FP to request and PP to provide specific identification parameters. (GAP-N.13)

**service class indication/assignment [DPRS-N.14]:** assignment by the FP to PP of the service class and indication to the FP by the PP of the contents of its service class. (GAP-N.14)

**alerting [DPRS-N.15]:** activates or deactivates alerting at the PP using any appropriate indication. (GAP-N.15)

**ZAP [DPRS-N.16]:** the ability first to assign and then to re-program the account data held in the PP so that access rights may be suspended subject to the conditions set by the service provider being met, coupled with the ability to re-program the account data again to reinstate access rights once these conditions have been met. One ZAP field shall be provided per account field. The PP has the right to authenticate the FP prior to the execution of ZAP suspend. (GAP-N.16)

**encryption activation FT initiated [DPRS-N.17]:** the activation of the encryption process requested by FT. (GAP-N.17)

**subscription registration procedure on-air [DPRS-N.18]:** a standardized procedure for loading subscription registration data into a PP in real time over the air-interface. (GAP-N.18)

**link control [DPRS-N.19]:** the ability to request, accept, maintain and release a data link for the purposes of a NWK layer procedure. (GAP-N.19)

**terminate access rights FT initiated [DPRS-N.20]:** the ability of the FP to delete a subscription in the PP. (GAP-N.20)

**partial release [DPRS-N.21]:** the ability to release an established or in progress Call Control (CC) call whilst retaining the radio resource for the purpose of accessing further services. (GAP-N.21)

**go to DTMF (infinite tone length) [DPRS-N.22]:** go to DTMF signalling, indicating infinite DTMF tone duration. (GAP-N.22)

**go to pulse [DPRS-N.23]:** go to pulse (decadic) signalling. (GAP-N.23)

**signalling of display characters [DPRS-N.24]:** the transmission to the PP of characters to be displayed on the user's PP display (if provided). (GAP-N.24)

**display control characters [DPRS-N.25]:** characters sent to the PP to control the user's display in the PP (if provided). Such characters include cursor control, clear screen, home, flash, inverse video etc. (GAP-N.25)

**authentication of FT [DPRS-N.26]:** the process by which the identity of a FP is checked by the PP. (GAP-N.26)

**encryption activation PT initiated [DPRS-N.27]:** the activation of the encryption process suggested by PT. The real time start of ciphering is done in the MAC layer and is always initiated by the PT. (GAP-N.27)

**encryption deactivation FT initiated [DPRS-N.28]:** the deactivation of the encryption process requested by FT. The real time stop of ciphering is done in the MAC layer and is always initiated by the PT. (GAP-N.28)

**encryption deactivation PT initiated [DPRS-N.29]:** the deactivation of the encryption process suggested by PT. The real time stop of ciphering is done in the MAC layer and is always initiated by the PT. (GAP-N.29)

**Calling Line Identification Presentation (CLIP) [DPRS-N.30]:** the ability to provide the calling party number to the called party before accepting the call. (GAP-N.30)

**internal call [DPRS-N.31]:** a call between 2 users that does not make use of the local network resources. This is typically useful in residential environments. (GAP-N.31)

**service call [DPRS-N.32]:** a call initiated by a DECT PT for entering of FT related service and adjustment procedures in a transparent way. After having sent the service call indication, the PT behaves according to the rules of a normal call. (GAP-N.32)

**Dynamic parameters allocation [DPRS-N.33]:** the ability to assign/negotiate DPRS protocol handling specific parameters.

**Service Negotiation [DPRS-N.34]:** the ability to negotiate call/service parameters during call set-up.

**In call service change [DPRS-N.35]:** the ability to modify call/service parameters (e.g. bandwidth, IWU parameters etc.) while the call is maintained.

**NWK layer management [DPRS-N.36]:** management of NWK layer related data (e.g. identities, location registration, etc.).

**Identity assignment [DPRS-N.37]:** the ability to assign and store different types of PT related identities.

**DECT external handover [DPRS-N.38]:** external handover is the process of switching a call in progress from one Fixed Part (FP-1) to another Fixed Part (FP-2). This means the handover occurs between two independent systems, where each system has its own lower layers of protocol and has an independent set of network layer Service Access Points (SAPs). To make external handover possible, a common management entity above the two fixed terminations is necessary. (CAP-N.1)

**Message waiting indication [DPRS-N.39]:** this feature enables a user to receive an indication of the status of a message server (e.g. a voice mailbox) to which the user has access to. (CAP-N.4)

**Detach [DPRS-N.40]:** this feature enables a PT to report to the FT that the PT is not ready to receive calls. (CAP-N.5)

**Enhanced location registration [DPRS-N.41]:** this feature enables automatic location registration of PT at expected intervals of time. (CAP-N.6)

**On-air modification of user parameters [DPRS-N.42]:** this feature enables the FT to modify the active subscription data of the PT. (CAP-N.7)

### 4.3.5 Application service definitions

**AC to bitstring mapping [DPRS-A.1]:** mapping of the AC into a bitstring. (GAP-A.1)

**multiple subscription registration [DPRS-A.2]:** the ability of PP to store more than one subscription. (GAP-A.2)

**manual entry of the Portable Access Rights Key (PARK) [DPRS-A.3]:** the ability of the PP to accept a manual entry of the PARK for ensuring attachment to the right FP in a physical area covered by many providers. (GAP-A.3)

### 4.3.6 Distributed Communication

**Distributed Communication [DPRS-DC.1]:** the ability of a DECT terminal to provide means for or assist direct communication between two terminals, members of a closed local DECT network. Such terminals may be of type HyP, or, of type PP or FP (when additional specific procedures are provided).

---

## 5 PHL requirements

The requirements of EN 300 444 [8], clause 11, shall apply.

---

## 6 MAC layer requirements

In case of mobility class 2, the MAC extended fixed part information message shall be used and, therefore, bit a12 of the fixed part information field shall be set to 1.

## 6.1 MAC services

**Table 3: MAC service support for mobility class 1 and 2**

Item	Name of service	Support status	
		PT	FT
DPRS-M.1	General	M	M
DPRS-M.2	Non continuous broadcast	O	O
DPRS-M.3	Continuous broadcast	M	M
DPRS-M.4	Paging broadcast	M	M
DPRS-M.5	Advanced connections	M	M
DPRS-M.6	Ip_error_detection service	M	M
DPRS-M.7	Ip_error_correction service	O	O
DPRS-M.8	U-plane point-to-multipoint service	O	O
DPRS-M.9	C <sub>S</sub> higher layer signalling	C31	C31
DPRS-M.10	C <sub>F</sub> higher layer signalling	C32	C32
DPRS-M.11	Encryption activation	M	M
DPRS-M.12	Encryption deactivation	C33	C33
DPRS-M.13	Quality control	M	M
DPRS-M.14	Physical channel selection	M	M
DPRS-M.15	SARI support	C31	C32
DPRS-M.16	Bearer replacement	M	M
DPRS-M.17	Bearer handover	O	O
DPRS-M.18	Connection handover	M	O
DPRS-M.19	G <sub>F</sub> -channel	M	M
C31:	IF (CLASS 1) THEN I ELSE M.		
C32:	IF (CLASS 1) THEN I ELSE O.		
C33:	If DPRS-N.28 or DPRS-N.29 then M else I.		



## 6.2 MAC service to procedure mapping

**Table 4: MAC service to procedure mapping**

Service	Procedure	Ref.	Status	
			PT	FT
DPRS-M.1 General			M	M
	General	10.1	M	M
DPRS-M.2 Non continuous broadcast			O	O
	Request for specific Q-channel information	10.2.1	O	O
	Request for a new dummy	10.2.2	O	O
DPRS-M.3 Continuous broadcast			M	M
	Downlink broadcast	10.3.1, 10.3.2	M	M
DPRS-M.4 Paging broadcast			M	M
	Normal paging	10.4.1, 10.4.3	M	M
	Fast paging	10.4.1, 10.4.3	O	M
	Low duty cycle paging	10.4.1, 10.4.3	O	O
	MAC paging	10.4.1, 10.4.3	M	M
DPRS-M.5 Advanced connection			M	M
	Fast setup	10.5	O	M
	Logical connection setup	10.5	M	M
	Logical connection release	10.6	M	M
	Connection modification	10.7	M	M
DPRS-M.6 Ip_error_detection service			M	M
	Ip-error-detect mode	10.13.1	M	M
DPRS-M.7 Ip_error_correction service			O	O
	Ip-error-correct mode	10.13.2	M	M
DPRS-M.8 U-plane point-to-multipoint service			O	O
	Connectionless SIp mode	10.13.3	M	M
DPRS-M.9 C <sub>S</sub> higher layer signalling			C41	C41
	C <sub>S</sub> -channel data	10.14.1	M	M
DPRS-M.10 C <sub>F</sub> higher layer signalling			C42	C42
	C <sub>F</sub> -channel data	10.14.2	M	M
DPRS-M.11 Encryption activation			M	M
	Encryption process - initialization and synchronization	10.15.1	M	M
	Encryption mode control	10.15.2	M	M
	Encryption handover control	10.15.3	M	M
DPRS-M.12 Encryption deactivation			C43	C43
	Encryption mode control	10.15.2	M	M
DPRS-M.13 Quality control			M	M
	RFPI handshake	10.16.1	M	M
	PT frequency correction procedure	10.16.2	O	O
	Bearer quality report	10.16.3	M	M
	Bearer and connection quality control	10.16.4	M	M
	A-CRC handshake	10.16.5	M	M
DPRS-M.14 Physical channel selection			M	M
	Physical channel selection	10.17	M	M
DPRS-M.15 SARI support			C41	C42
	Downlink broadcast	10.3.2.4	M	M

Service	Procedure	Ref.	Status	
			PT	FT
DPRS-M.16 Bearer replacement			M	M
	Bearer replacement	10.18	M	M
DPRS-M.17 Bearer handover			O	O
	Bearer handover	10.19	M	M
DPRS-M.18 Connection handover			M	O
	Advanced connection handover	10.12	M	M
DPRS-M.19 G <sub>F</sub> -channel			M	M
	G <sub>F</sub> -channel data	10.20.1	M	M
C41: IF (CLASS 1) THEN I ELSE M.				
C42: IF (CLASS 1) THEN I ELSE O.				
C43: If DPRS-N.28 or DPRS-N.29 then M else I.				

NOTE: The reference column refers to the relevant subclause in the present document.

## 7 DLC-layer requirements

### 7.1 DLC services

Table 5: DLC service status

Item no.	Name of service	Ref.	Status	
			PT	FT
DPRS-D.1	LU10 Enhanced Frame RELay service (EFREL)	4.3.3	M	M
DPRS-D.2	FU10a	4.3.3	M	M
DPRS-D.3	FU10b	4.3.3	O	O
DPRS-D.4	FU10c	4.3.3	M	M
DPRS-D.5	Data Link Service (LAPC+Lc) class A service	4.3.3	M	M
DPRS-D.6	Data Link Service (LAPC+Lc) class U service	4.3.3	O	O
DPRS-D.7	Lc Frame delimiting and sequencing service	4.3.3	M	M
DPRS-D.8	Broadcast Lb service	4.3.3	M	M
DPRS-D.9	Inter-cell voluntary connection handover	4.3.3	M	O
DPRS-D.10	Connection modification	4.3.3	M	M
DPRS-D.11	Encryption activation	4.3.3	M	M
DPRS-D.12	Encryption deactivation	4.3.3	C51	C51
C51: if DPRS-N.28 or DPRS-N.29 then M else I.				

## 7.2 DLC feature to procedure mapping

**Table 6: DLC service to procedure mapping**

Service	Procedure	Ref.	Status	
			PT	FT
DPRS-D.1 LU10 Enhanced Frame RELay service (EFREL)		4.3.3	M	M
	U-plane class 2	11.1.1	M	M
DPRS-D.2 FU10a		4.3.3	M	M
	FU10a frame operation	11.2.1	M	M
DPRS-D.3 FU10b		4.3.3	O	O
	FU10b frame operation	11.2.2	M	M
DPRS-D.4 FU10c		4.3.3	M	M
	FU10c frame operation	11.2.3	M	M
DPRS-D.5 Data Link Service (LAPC+Lc) class A service		4.3.3	M	M
	class A link establishment	11.3.1	M	M
	class A acknowledged information transfer	11.3.2	M	M
	class A link release	11.3.3	M	M
	class A link re-establishment	11.3.4	M	M
DPRS-D.6 Data Link Service (LAPC+Lc) class U service		4.3.3	O	O
	class U link establishment	11.5.1	M	M
	class U use of LLN for unacknowledged information transfer	11.5.2	M	M
	class U unacknowledged information transfer	11.5.3	M	M
	class U unacknowledged release	11.5.4	M	M
DPRS-D.7 Lc Frame delimiting and sequencing service		4.3.3	M	M
	C <sub>S</sub> -channel fragmentation and recombination	11.6.1	M	M
	C <sub>F</sub> -channel fragmentation and recombination	11.6.2	O	O
	Selection of logical channels (C <sub>S</sub> and C <sub>F</sub> )	11.6.3	M	M
DPRS-D.8 Broadcast Lb service		4.3.3	M	M
	Normal operation	11.7.1	M	M
	Expedited operation	11.7.2	C62	C62
DPRS-D.9 Inter-cell voluntary connection handover		4.3.3	M	O
	class A connection handover	11.8.1	M	M
DPRS-D.10 Connection modification		4.3.3	M	M
	Connection modification	11.9	M	M
DPRS-D.11 Encryption activation		4.3.3	M	M
	Encryption switching	11.10	M	M
	Connection handover of ciphered connection	11.10.2.2	M	M
DPRS-D.12 Encryption deactivation		4.3.3	C63	C63
	Encryption switching	11.10	M	M
C62: If N.19 - fast paging implemented then M else I.				
C63: If DPRS-N.28 or DPRS-N.29 then M else I.				

NOTE: The reference column refers to the relevant clause in the present document, except where stated otherwise.

---

## 8 NWK layer requirements

The NWK layer provisions shall include the following entities:

- Call Control (CC);
- Mobility Management (MM);
- Link Control Entity (LCE);
- Connectionless Message Service (CLMS).

Only mobility class 2 equipment requires a NWK layer. For mobility class 1 equipment configuration parameters shall be according to annex A of the present document.

All NWK layer procedures, unless explicitly stated shall be as defined in GAP-EN 300 444 [8], or when relevant, as defined in CAP-EN 300 824 [9].

## 8.1 NWK features

Table 7: NWK features status

Feature supported				
Features			Status	
Item no.	Name of feature	Ref	PT	FT
DPRS-N.1	Outgoing call	4.3.4	O	O
DPRS-N.2	Off hook	4.3.4	M	M
DPRS-N.3	On hook (full release)	4.3.4	M	M
DPRS-N.4	Dialled digits (basic)	4.3.4	O	O
DPRS-N.5	Register recall	4.3.4	O	O
DPRS-N.6	Go to DTMF signalling (defined tone length)	4.3.4	O	O
DPRS-N.7	Pause (dialling pause)	4.3.4	O	O
DPRS-N.8	Incoming call	4.3.4	O	O
DPRS-N.9	Authentication of PP	4.3.4	M	M
DPRS-N.10	Authentication of user	4.3.4	O	O
DPRS-N.11	Location registration	4.3.4	M	O
DPRS-N.12	On air key allocation	4.3.4	M	O
DPRS-N.13	Identification of PP	4.3.4	O	O
DPRS-N.14	Service class indication/assignment	4.3.4	O	O
DPRS-N.15	Alerting	4.3.4	O	O
DPRS-N.16	ZAP	4.3.4	O	O
DPRS-N.17	Encryption activation FT initiated	4.3.4	M	M
DPRS-N.18	Subscription registration procedure on-air	4.3.4	M	M
DPRS-N.19	Link control	4.3.4	M	M
DPRS-N.20	Terminate access rights FT initiated	4.3.4	M	O
DPRS-N.21	Partial release	4.3.4	O	O
DPRS-N.22	Go to DTMF (infinite tone length)	4.3.4	O	O
DPRS-N.23	Go to Pulse	4.3.4	O	O
DPRS-N.24	Signalling of display characters	4.3.4	O	O
DPRS-N.25	Display control characters	4.3.4	O	O
DPRS-N.26	Authentication of FT	4.3.4	O	O
DPRS-N.27	Encryption activation PT initiated	4.3.4	O	O
DPRS-N.28	Encryption deactivation FT initiated	4.3.4	O	O
DPRS-N.29	Encryption deactivation PT initiated	4.3.4	O	O
DPRS-N.30	Calling Line Identification Presentation (CLIP)	4.3.4	O	O
DPRS-N.31	Internal call	4.3.4	O	O
DPRS-N.32	Service call	4.3.4	O	O
DPRS-N.33	Dynamic parameters allocation	4.3.4	M	M
DPRS-N.34	Service Negotiation	4.3.4	M	M
DPRS-N.35	In call service change	4.3.4	O	O
DPRS-N.36	NWK layer management	4.3.4	M	M
DPRS-N.37	Identity assignment	4.3.4	O	O
DPRS-N.38	DECT External handover	5.1 [9]	O	O
DPRS-N.39	Message Waiting Indication	5.1 [9]	O	O
DPRS-N.40	Detach	5.1 [9]	O	O
DPRS-N.41	Periodic location registration	5.1 [9]	O	O
DPRS-N.42	On-air modification of user parameters	5.1 [9]	O	O

## 8.2 NWK feature to procedure mapping

Reference in the following table are to the present document unless otherwise specified.

**Table 8: NWK feature to procedure mapping**

Feature/Procedure mapping			Status	
Feature	Procedure	Ref.	PT	FT
DPRS-N.1, Outgoing call		4.3.4	O	O
	Outgoing call request	12.1	M	M
	Overlap sending	8.3 [8]	M	O
	Outgoing call proceeding	8.4 [8]	M	O
	Outgoing call confirmation	8.5 [8]	M	O
	Outgoing call connection	8.6 [8]	M	M
DPRS-N.2, Off Hook		4.3.4	M	M
	Outgoing call request	8.2 [8]	M	M
	Incoming call connection	8.15 [8]	M	M
DPRS-N.3, On Hook (full release)		4.3.4	M	M
	Normal call release	8.7 [8]	M	M
	Abnormal call release	8.8 [8]	M	M
DPRS-N.4, Dialed digits (basic)		4.3.4	O	O
	Sending keypad information	8.10 [8]	M	M
DPRS-N.5, Register recall		4.3.4	O	O
	Sending keypad information	8.10 [8]	M	M
DPRS-N.6 Go to DTMF signalling (defined tone length)		4.3.4	O	O
	Sending keypad information	8.10 [8]	M	M
DPRS-N.7, Pause (dialling pause)		4.3.4	O	O
	Sending keypad information	8.10 [8]	M	M
DPRS-N.8, Incoming call		4.3.4	O	O
	Incoming call request	12.2	M	M
	Incoming call confirmation	8.13 [8]	M	M
	PT alerting	8.14 [8]	M	M
	Incoming call connection	8.15 [8]	M	M
DPRS-N.9, Authentication of the PP		4.3.4	M	M
	Authentication of PT	8.24 [8]	M	M
DPRS-N.10, Authentication of the user		4.3.4	O	O
	Authentication of user	8.25 [8]	M	M
	Location registration	4.3.4	M	O
DPRS-N.11, Location registration	Location registration	8.28 [8]	M	M
	Location update	8.29 [8]	M	O
	Terminal capability indication	12.3	M	M
		4.3.4	M	O
DPRS-N.12, On air key allocation	Key allocation	8.32 [8]	M	M
		4.3.4	O	O
DPRS-N.13, Identification of PP	Identification of PT	8.22 [8]	M	M
		4.3.4	O	O
DPRS-N.14, Service class indication/assignment	Obtaining access rights	8.30 [8]	M	M
	Authentication of PT	8.24 [8]	M	M
		4.3.4	O	O
DPRS-N.15, Alerting	PT alerting	8.14 [8]	M	M
		4.3.4	O	O
DPRS-N.16, ZAP		4.3.4	O	O
	Obtaining access rights	8.30 [8]	M	M
	Incrementing the ZAP value	8.26 [8]	M	M
	Authentication of FT	8.23 [8]	O	M
DPRS-N.17, Encryption activation FT initiated		4.3.4	M	M
	Cipher-switching initiated by FT	8.33 [8]	M	M
	Storing the Derived Cipher Key (DCK)	8.27 [8]	M	M
DPRS-N.18, Subscription registration user procedure on-air		4.3.4	M	M
	Obtaining access rights	8.30 [8]	M	M

Feature/Procedure mapping			Status	
Feature	Procedure	Ref.	PT	FT
	Terminal capability indication	12.3	M	M
DPRS-N.19, Link control		4.3.4	M	M
	Indirect FT initiated link establishment	12.15	M	M
	Fast Paging	12.15	O	O
	Collective and group ringing	12.17	O	O
	Direct FT initiated link establishment	12.18	O	O
	Direct PT initiated link establishment	8.36 [8]	M	M
	Link release "normal"	8.37 [8]	M	M
	Link release "abnormal"	8.38 [8]	M	M
	Link release "maintain"	8.39 [8]	I	I
	LCE Resume Paging	12.19	M	C81
DPRS-N.20, Terminate access rights FT initiated		4.3.4	M	O
	FT terminating access rights	8.31 [8]	M	M
	Authentication of FT	8.23 [8]	O	O
DPRS-N.21, Partial release		4.3.4	O	O
	Partial release	8.9 [8]	M	M
DPRS-N.22, Go to DTMF (infinite tone length)		4.3.4	O	O
	Sending keypad information	8.10 [8]	M	M
DPRS-N.23, Go to Pulse		4.3.4	O	O
	Sending keypad information	8.10 [8]	M	M
DPRS-N.24, Signalling of display characters		4.3.4	O	O
	Display	8.16 [8]	M	M
	Terminal capability indication	12.3	M	M
DPRS-N.25, Display control characters		4.3.4	O	O
	Display	8.16 [8]	M	M
	Terminal capability indication	12.3	M	M
DPRS-N.26, Authentication of FT		4.3.4	O	O
	Authentication of FT	8.23 [8]	M	M
DPRS-N.27, Encryption activation PT initiated		4.3.4	O	O
	Cipher-switching initiated by PT	12.13	M	M
	Storing the DCK	8.27 [8]	M	M
DPRS-N.28, Encryption deactivation FT initiated		4.3.4	O	O
	Cipher-switching initiated by FT	8.33 [8]	M	M
DPRS-N.29, Encryption deactivation PT initiated		4.3.4	O	O
	Cipher-switching initiated by PT	12.13	M	M
DPRS-N.30, Calling Line Identification Presentation (CLIP)		4.3.4	O	O
	Incoming call request	8.12 [8]	M	M
DPRS-N.31, Internal call		4.3.4	O	O
	Internal call set-up	8.18 [8]	M	M
	Internal call keypad	12.4	O	O
DPRS-N.32, Service call		4.3.4	O	O
	Service call set-up	8.20 [8]	M	M
	Service call keypad	8.21 [8]	O	O
DPRS-N.33, Dynamic parameters allocation		4.3.4	M	M
	Dynamic parameters allocation	12.11	M	M
DPRS-N.34, Service Negotiation		4.3.4	M	M
	Call Resources/Parameters negotiation	12.5	M	M
DPRS-N.35, In call service change		4.3.4	O	O
	Bandwidth Change	12.6	M	M
	Connection Reversal	12.7	M	M
	IWU-attributes change	12.9	M	M
DPRS-N.36, NWK layer management		4.3.4	M	M
	Management of MM procedures	12.19	M	M
	Management - Location registration initiation	13.2 [8]	M	M

Feature/Procedure mapping			Status	
Feature	Procedure	Ref.	PT	FT
	Management - Assigned individual TPUI	13.4 [8]	M	M
	Management - PMID	13.5 [8]	M	M
	Management - DCK	13.6 [8]	M	M
	Management - Broadcast attributes	12.17 [8]	M	M
	Management - Storage of subscription related data	13.7 [8]	M	M
	U-plane handling	12.18	M	M
DPRS-N.37, Identity Assignment		4.3.4	O	O
	Temporary Identity Assign	12.14	M	M
DPRS-N.38, DECT External handover		5.1 [9]	O	O
	Handover candidate indication	9.1.1.1 [9]	M	M
	Handover candidate retrieval	9.1.1.2 [9]	M	O
	Target FP selection	9.1.2 [9]	M	M
	Handover reference indication	9.1.3.1 [9]	M	M
	Handover reference retrieval	9.1.3.2 [9]	M	C82
	External handover call setup	9.1.4 [9]	M	M
	Ciphering procedure PT initiated	9.1.5.1 [9]	O	O
	Ciphering procedure FT initiated	9.1.5.2 [9]	M	M
	U-plane handling	12.21 [9]	M	M
DPRS-N.39, Message Waiting Indication		5.1 [9]	O	O
	Message waiting indication	9.7 [9]	M	M
DPRS-N.40, Detach		5.1 [9]	O	O
	Detach	9.5 [9]	M	M
DPRS-N.41, Periodic location registration		5.1 [9]	O	O
	Enhanced location registration	9.6 [9]	M	M
DPRS-N.42, On-air modification of user parameters		5.1 [9]	O	O
	On-air modification of user parameters	9.8 [9]	M	M
	FT authentication	8.23 [9]	M	M
C81:	If single cluster system: O else M.			
C82:	At least one of these procedures shall be supported.			

## 8.3 Application features

Reference in the following table are to the present document unless otherwise specified.

**Table 9: Application feature to procedure mapping**

Feature supported			Status	
Item no.	Name of feature	Ref.	PT	FT
DPRS-A.1	AC_bitstring_mapping	4.3.5	M	M
DPRS-A.2	Multiple subscription registration	4.3.5	O	N/A
DPRS-A.3	Manual entry of the PARK	4.3.5	O	N/A



## 8.4 Application feature to procedure mapping

Reference in the following table are to the present document unless otherwise specified.

**Table 10: Application feature to procedure mapping**

Feature supported			Status	
Item no.	Name of feature	Ref.	PT	FT
DPRS-A.1, AC to bitstring mapping		4.3.5	M	M
	AC to bitstring mapping	14.2 [8]	M	M
DPRS-A.2, Multiple subscription registration		4.3.5	O	N/A
	Subscription control	14.1 [8]	M	N/A
DPRS-A.3, Manual entry of the PARK		4.3.5	O	N/A
	Manual entry of the PARK	14.3 [8]	M	N/A

## 8.5 Distributed Communications

Reference in the following table are to the present document unless otherwise specified.

**Table 11: Distributed Communication procedure status**

Feature/Procedure mapping					
Feature/Procedure			Status		
Feature Name	Procedure name	Ref.	PT	FT	HyP
DPRS-DC.1		4.3.6	O	O	M
	General Requirements	E.2	M	M	M
	HyP Identities handling	E.3.1	N/A	M	M
	Membership Access Rights Allocation	E.3.2	M	M	M
	Re-initialization of membership access rights	E.3.3	M	M	M
	Members Data Transfer	E.3.4	M	M	M
	Presence/Absence Indication	E.3.5	M	M	M
	Bandwidth management	E.3.6	M	M	M
	Direct Link Establishment	E.3.7	M	M	M
	Indirect Link Establishment	E.3.8	M	M	M
	MASTER management	E.3.9	M	M	M
	Common Subscription Database management	E.3.10	M	M	M
	Handover issues	E.3.11	M	M	M
	Usage of PPs or FPs in DCDL-net	E.6	M	M	M

---

## 9 Management Entity Requirements

### 9.1 Introduction

The Management Entity (ME) is responsible for:

- management of user logical connections;
- management of physical resources;
- maintenance and updating of the logical associations C-plane and U-plane entities inside and among the different levels of the DECT stack: IWUs, NWK, DLC and MAC;
- management of mobility capabilities supported by service class 2;
- MAC MBC logical connection management;
- MAC TBC and physical connection management;
- DLC U-plane management;
- DLC C-plane management;
- connection handover management (optional).

### 9.2 Description of the DPRS operation principles

#### 9.2.1 General

In DPRS, the management of the "physical connections" is always under control of the Management Entity (ME). The ME decides in real time the activation, release, or change of bandwidth of the physical connection, based on the existence of U-plane data or C-plane messages to be transmitted, and according to the requirements described in this subclause. The higher layer entities are responsible for the presence or absence of the valid data at the MAC service boundaries upon which such lower layer resource management is based.

#### 9.2.2 Service class 1

Service class 1 is a simplified version of DPRS that does not incorporate C-plane. Class 1 is intended for small private applications with restricted mobility and control features. Because of back-compatibility reasons, class 1 uses an specific ad-hoc solution with some differences with class 2 equipment.

In service class 1, the "physical connection", the MBC instance, and the DLC link, are permanently associated. The activation and release of the physical resources are done by set-up and release of the DLC "link". All requirements provided in this subclause are valid, taken into account that the activation or release of a "physical connection" have associated the activation or release of the MBC and DLC layers.

Service class 1 provides an user service that is equivalent to a Permanent Virtual Circuit (PVC).

#### 9.2.3 Service class 2

Service class 2 provides additionally the capabilities of the DECT C-plane. In service class 2, any NWK layer service is permanently mapped to a DLC layer "link" and to a MBC logical instance called "logical connection". All these entities exist during the length of an user connection. User connections could be "Virtual calls" (VC) or "Permanent Virtual Circuits" (PVC).

The allocation of physical resources to the "logical connection" is performed in real time by the Management Entity, based on the existence of U-plane data or C-plane messages to be transmitted, and according to the requirements described in this subclause. The set of bearers and TBC's temporally allocated to a "logical connection" is the "physical connection".

A "logical connection" is in active state if it has associated a "physical connection" and in suspended state otherwise.

## 9.3 Resource and physical connection management

This section describes when a "Physical Connection" should be set up or released, and which procedures should be used.

### 9.3.1 Requirements applicable to the Fixed Part (FP)

#### 9.3.1.1 Conditions for resumption and management procedures

##### 9.3.1.1.1 General

The FP may resume a Physical Connection, if any of the following conditions meet:

- there are user plane data to be transmitted downstream;
- there are high layer C-plane data to be transmitted downstream (applicable only to service class 2);
- there are MAC control messages to be transmitted downstream.

NOTE: The activation of the Physical Connection as consequence of the handshake procedure is considered as part of condition 3 (see subclause 9.4.2.5).

##### 9.3.1.1.2 ME procedures for FT initiated connection resumption.

For equipment of both mobility class 1 and mobility class 2, MAC connection establishment from the FP to the PP goes as follows.

The FP shall try to establish the Physical Connection using the FT initiated set-up procedure (fast set-up) (see subclause 10.10.1.2) if the PP supports fast set-up and is supposed to be in idle-locked state with set-up detection.

- The PP will be supposed to be in idle-locked state with set-up detection if the time elapsed since the Physical Connection was released by last time is lower than timer T909.

The fast set-up procedure should result in at least one set-up attempt. If the PP is supposed not to be in idle-locked state with set-up detection, then the fast set-up is not required.

If Fast set-up procedure has failed or has not been used, then the FP may try to establish the Physical Connection using MAC-resume paging (see subclause 10.4), if the PP is known to support MAC-resume paging.

In this case, the FP shall use Fast MAC-resume paging (see subclause 10.4), if the PP is known to support fast paging, and use normal MAC-resume paging (see subclause 10.4) otherwise.

- The ME may freely choose the number of MAC-paging attempts.

NOTE: MAC paging is not required if the FP has done a Fast Setup attempt and Fast Setup is supported by the PP.

If the previous set-up procedures have failed, the FP shall try to establish the Physical Connection using LCE-resume paging (see subclause 12.16). The FP shall use fast LCE-resume paging, if the PP is known to support fast paging, otherwise it shall use normal paging. The fast paging should result in at least one paging attempt.

If the fast paging fails or if the PP does not support fast paging then the FP tries to establish a Physical Connection with normal LCE-resume paging.

In case of no response from the PT, the FT may repeat the paging attempt according to implementation specific algorithms. Process may continue until violation of the handshake (stay alive) procedure (subclause 9.4.2.5), when the connection shall be released.

### Class 1 systems

For class 1 systems, the paging shall be initiated by the ME, by issuing a MAC\_PAGE-req primitive. The SDU passed with the primitive shall be such that the contents of the paging message is as defined in EN 300 175-5 [5], subclause 8.2.1, short format message, using default TPUI, with the following exception:

- the LCE header field shall have the value 111 (Ip-error-correct), or 110 (Ip-error-detect).

Receipt of a paging message with a mobility class 1 TPUI indicates that the paging message should be handled by the ME. Upon receipt of a MAC-PAGE-ind primitive with the TPUI of the PP as parameter, the ME shall issue a MAC\_CON-req primitive.

### Class 2 Systems: MAC-resume paging

The MAC resume paging shall be done according to subclause 10.4.

### Class 2 Systems: LCE-resume paging

The LCE resume paging shall be done according to the procedure described in subclause 12.16.

## 9.3.1.2 Connection Suspension conditions

### 9.3.1.2.1 General

The ME of the FP may request a suspension of the connection at any time according to implementation specific algorithms.

In addition to that, the FP shall request a suspension of the connection in the following cases:

- in case of no user-data or C-plane activity;
- by violation of the minimum number of bearers (MAC Bandwidth command);
- by loss of all received bearers.

The PP is allowed to reject an FP initiated suspension only if the minimum number of bearers negotiated at NWK layer is unequal to zero, and the PP has C-plane or U-plane data ready to be send upstream. In any case, the FP is allowed to force the PP down to the minimum number of bearers, negotiated by the NWK layer.

### 9.3.1.2.2 Connection suspension due to no data activity

The ME of the FP shall request a suspension of the connection if no new PDU or C-plane message has been transmitted or received during a consecutive period of T903.

NOTE: Timer T903 is set by the FP (see annex A).

### 9.3.1.2.3 Connection suspension due to violation of the minimum number of bearers (MAC Bandwidth command)

The FP shall suspend the connection if the MAC layer is unable to set the "minimum number of bearers" for any of the directions of the connection, and this situation exists for more time than T906. See subclause 10.7.3 for the suspend procedure.

NOTE: See annex A for definition and value of T906.

### 9.3.1.2.4 Connection suspension by loss of all received bearers

The FP will suspend the connection if all received bearers of the connection are lost, and this situation exists for more time than T908.

NOTE: See annex A for definition and value of T908.

### 9.3.1.3 Activation of Fast Scan mode after Connection suspension

After the suspension of the connection, if the PP supports fast set-up, and parameter T909 (annex A) (class 2 devices) is different from zero, the PP shall pass to Idle-locked state with set-up detection (fast scan mode), as defined in EN 300 175-3 [3], subclause 11.3.3.2.

The PP shall remain in this state for at least the time specified in the parameter T909. During this time, the PP shall accept FT initiated bearer set-up using the procedure defined in (see to clause 10). After this time the PP may pass to normal Idle-locked state with page detection (EN 300 175-3 [3], subclause 11.3.3.1).

For service class 1 equipment the value of T909 is stored in the PP configuration table (see clause A.2).

For service class 2 equipment, T909 is variable parameter that can be negotiated between FT and PT by means of the <<SETUP-CAPABILITY>> NWK layer information element (see subclause A.1.3.2).

PTs that do not support fast set-up can ignore this information element.

### 9.3.1.4 Conditions for Bandwidth modification

#### 9.3.1.4.1 General

The ME of the FP could decide a change in the bandwidth of a connection at any time according to implementation specific algorithms. The FP will use the Bandwidth modification procedure described in subclause 10.7).

The PP shall mandatorily accept any change of Bandwidth instanced by the FP if the requested bandwidth is within the maximum and minimum values negotiated at NWK layer.

## 9.3.2 Requirements applicable to the Portable Part (PP)

### 9.3.2.1 Conditions for connection resumption

The Connection will be resumed by the PP if and only if any of the following conditions meet:

- the PP has U-plane data ready to be sent upstream;
- the PP has C-plane data ready to be sent upstream;
- the PP has MAC control messages to be transmitted upstream;
- the PP initiated this procedure with the result of being refused by the FP, as described in subclause 9.3.2.1.5, and a time equal to WtB ("Waiting time B"), defined in annex A, has elapsed.

NOTE: The resumption of the Physical Connection as consequence of the handshake procedure is considered as part of condition 3.

If the connection was previously suspended by the FP, (subclause 9.3.1.2.1), the PP shall not request a connection resume during an interval equal to WtB ("Waiting time B") as defined in annex A.

#### 9.3.2.1.1 Procedure for PT initiated Connection resumption.

The sequence of procedures for the resumption of a connection shall consist on PT initiated pilot bearer set-up (subclause 10.10) followed by connection modification (subclause 10.7).

#### 9.3.2.1.2 "RFP-busy-for-data" flag

The PT shall not initiate the PT initiated connection resumption procedure if the RFP has activated the RFP-busy-for-data flag in RFP status (EN 300 175-3 [3], subclause 7.2.4.3.9).

### 9.3.2.1.3 Waiting time for collision avoidance after deactivation of "RFP-busy-for-data" flag

If the RFP had activated the RFP-busy-for-data flag in RFP status (EN 300 175-3 [3], 7.2.4.3.9), after the deactivation of this flag, the PT shall wait a random interval WtA (see subclause A.1.2.1) before initiating any bearer set-up procedure, to prevent access collisions. In case of access collision during the following PT initiated set-up procedure (subclause 10.10), the PT shall wait a random interval WtA before repeating the access request attempt. In case of successive collisions, formula will be applied with successive increment in the spreading range.

### 9.3.2.1.4 Bandwidth after resumption

As consequence of the procedure, the FP will inform the PP about the number of bearers (bandwidth) to be used. This value shall be within the range negotiated by the network layer. The PP will use always the bandwidth mandated by the FP.

### 9.3.2.1.5 Resumption rejection by the FP

If as consequence of the set-up procedure, the FP rejects the access attempt with the message Bandwidth = zero, the PP will do the following actions:

- PT shall immediately release all bearers;
- PT shall wait the waiting time WtB (see subclause A.1.2.2) and shall repeat the pilot bearer set-up procedure (subclause 10.10).

In case of repetitive failures the waiting time WtB shall be increased to obtain congestion avoidance, according to the formulae given in annex A.

## 9.3.2.2 Conditions for Connection Suspension

### 9.3.2.2.1 General

The ME of the PP may request a suspension of the Connection at any time according to implementation specific algorithms.

In addition to that, the PP shall initiate a suspension of the Connection in the following cases:

- in case of no user-data or C-plane activity;
- by violation of the minimum number of bearers (MAC Bandwidth command);
- by loss of all received bearers.

The PP is allowed to reject an FP initiated suspension only if the minimum number of bearers negotiated at NWK layer is unequal to zero, and the PP has C-plane or U-plane data ready to be send upstream. In any case, the FP is allowed to force the PP down to the minimum number of bearers, negotiated by the NWK layer.

### 9.3.2.2.2 Connection suspension due to no data activity

The ME of the PP shall request a suspension of the connection if no new PDU or C-plane message has been transmitted or received during a consecutive period of T903.

NOTE: Timer T903 is broadcasted by the FP (see annex A).

### 9.3.2.2.3 Connection suspension due to violation of the minimum number of bearers (MAC Bandwidth command)

The PP shall suspend a Connection if the MAC layer is unable to set the "minimum number of bearers" for any of the directions of the connection, and this situation exists for more time than T906. See subclause 10.7.3 for suspend procedure.

NOTE: See annex A for definition and value of T906.

#### 9.3.2.2.4 Connection suspension by loss of all received bearers

The PP will suspend a Connection if all received bearers of the connection are lost, and this situation exists for more time than T908.

NOTE: See annex A for definition and value of T908.

#### 9.3.2.2.5 Activation of fast scan mode after Connection suspension

The same requirements specified in clause are applicable in this case.

### 9.3.2.3 Conditions for Bandwidth modification

#### 9.3.2.3.1 General

The ME of the PP could request a change in the bandwidth of a connection at any time according to implementation specific algorithms. The PP will use the Bandwidth modification procedure described in subclause 12.6.

The Bandwidth modification requested by the PP has the nature of suggestion. The FP is free to accept or not the Bandwidth modification requested by the PP. The PP will mandatorily accept the Bandwidth indicated by the FP in the answer to the Bandwidth message if the value is within the maximum and minimum values negotiated at NWK layer.

When as described in subclause 10.7, the PP requests a suspension of the Connection, the FP will decide, taken into account the existence or not of data downstream, whether to suspend the Connection, or to modify the bandwidth (i.e. reverting the direction). Decision is indicated in the values of the bandwidth message sent by the FP.

When a PT has requested a bandwidth modification that involves increasing the number of bearers, and it has been refused by the FT, the PT shall not repeat the request of bandwidth extension during an interval WtB (see subclause A.1.2.2).

NOTE: The PT may request bandwidth modification reducing number of bearers at any time.

## 9.4 Logical Connection management

This section describes when the "Logical Connections" should be suspended or released, and which procedures should be used.

### 9.4.1 Requirements for class 1 devices

In DPRS service class 1, the MBC and the DLC layer instances associated to a single "physical connection" are set up and released together with the "Physical Connection". There are no specific requirements for Logical connection management.

### 9.4.2 Requirements for class 2 devices

#### 9.4.2.1 General Description

DPRS service class 2 supports two types of user Connections: Virtual calls (VC) and Permanent Virtual Circuits (PVC).

"Virtual Calls" (VC) are packet-mode user connections that can be set up and released by means of NWK layer C-plane procedures. A "Virtual Call" is the equivalent in packet-mode to a circuit-mode "Call".

"Permanent Virtual Circuit" (PVC) are packet-mode user connections that are established and cleared by configuration. A "Permanent Virtual Circuit" is the equivalent in packet-mode to a circuit-mode "Leased Line".

In DPRS, service class 2, any user connection has permanently associated a DLC layer "link" and a MBC "logical connection".

### 9.4.2.2 Normal procedures of virtual call set-up and release

Virtual Calls are set up always by means of the NWK layer CC-SETUP (subclause 12.5) procedure. Set up of the Virtual Call will cause the creation of a DLC "link" and a MBC "logical connection" associated to the call.

The normal release of VC's is done by means of the NWK layer Call release procedure (see clause 12) The CC-RELEASE message (see clause 12) shall be exchanged between both peers. The releasing of the virtual call automatically causes the clearing of the DLC and MBC "logical connection" associated to the call.

### 9.4.2.3 Abnormal release of Virtual Calls

Virtual Calls may be released by the ME without NWK layer Call-release procedures in case of violation of the handshake (stay alive) procedure described in next subclause. The abnormal release of a virtual call automatically causes the clearing of the DLC and MBC "logical connection" associated to the call.

In the case of PVC's set up by configuration, the connections shall never be released. In case of failure of the handshake procedure, a notification will be send to the OAM subsystem in the FP side.

### 9.4.2.4 Release of Logical Connection

The MAC logical connection is released in the following cases:

- in case of normal release of the Virtual Call (see subclause 9.4.2.2);
- in case of abnormal release of the Virtual Call (see subclause 9.4.2.3);
- as consequence of connection handover procedure (see subclause 11.7).

### 9.4.2.5 The handshake (stay alive) procedure

To get a handshake control for suspended connections, a connection shall not be in suspended state for more than T910. To meet this rule, the PT is responsible to perform a handshake with the FT at least T910-T200 after entering the suspend state. In order to avoid connection release caused by a single bearer set-up procedure that failed, PTs shall perform such handshake in shorter time intervals than T910. The PT shall try five handshake attempts within T910. After successfull handshake (succesful bearer setup) the Timer T910 and the counter for handshake attempts shall be reset.

To perform a handshake, the PT shall execute a PT initiated pilot bearer set-up procedure (subclause 10.10) followed by a bandwidth modification with a requested value of zero.

NOTE 1: In order to expedite the process, the PT is allowed to send the messages "bearer request" and "bandwidth = 0" in the same frame.

The FP is allowed to initiate a handshake with the PT at any time.

If a MAC connection associated to a Virtual Call has been in suspend state for more than T910, the connection, including the controlling MBC, the associated DLC and the virtual call shall be released.

NOTE 2: As no physical connection is established, this clearing procedure doesn't need any further air interface (bearer release) procedure.

NOTE 3: T200 is the MAC connection set-up timer. Its value can be found in EN 300 175-3 [3], clause A.1.



---

## 10 MAC layer procedures

### 10.1 General

#### 10.1.1 Frame and multiframe structure

The FT and PT shall support frame and multiframe structures as defined in EN 300 175-3 [3] subclause 4.2.

#### 10.1.2 Bit mappings

The FT and PT shall support D-MAP D00 and D32, A-MAP, and protected format B-MAP as defined in EN 300 175-3 [3] subclause 6.2.1.

#### 10.1.3 Time multiplexers

The FT and PT shall support T-MUX, E/U-MUX E32 and U32b, and C-MUX as defined in EN 300 175-3 [3] subclause 6.2.2.

#### 10.1.5 Scrambling

The FT and PT shall support scrambling as defined in EN 300 175-3 [3] subclause 6.2.4.

#### 10.1.6 Error control

The FT and PT shall support R-CRC and X-CRC generation as defined in EN 300 175-3 [3] subclause 6.2.5.

#### 10.1.7 A-tail identifications

The FT and PT shall understand all A-field tail identifications (bits a0 to a2) as defined in EN 300 175-3 [3] subclause 7.1.2.

#### 10.1.8 B-field identifications

The FT and PT shall understand all B-field identifications (bits a4 to a6) as defined in EN 300 175-3 [3] subclause 7.1.4.

#### 10.1.9 RFP idle receiver scan sequence

The FT shall support primary scan as defined in EN 300 175-3 [3] subclause 11.8.

#### 10.1.10 PT receiver scan sequence

The PT receive scan sequence, whenever active, shall lead the RFP primary scan by one frame, as defined in EN 300 175-3 [3] subclause 11.9.

#### 10.1.11 PP states and state transitions

The procedure shall be performed as specified in EN 300 175-3 [3] subclause 11.3.3, with the following provisions:

- The PT shall allow fast setup (if supported) for a period of time immediately following the transition from Active\_Locked to Idle\_Locked state. The duration of this period is communicated to MAC by ME (see subclause 9.3.1.3).

## 10.1.12 Identities

The provisions of EN 300 175-3 [3] subclause 11.7 and EN 300 175-6 [6] shall be implemented with respect to the structure and use of identities.

## 10.2 Non continuous broadcast

### 10.2.1 Request for specific Q-channel information

The PT shall have the capability and the FT shall understand, requests for specific Q-channel information as defined in EN 300 175-3 [3] subclause 9.3.1.2.

The PT shall have the capability to initiate, and the FT shall understand a request for extended system information as defined in EN 300 175-3 [3] subclause 11.2.

### 10.2.2 Request for a new dummy

The PT shall have the capability to initiate, and the FT shall understand a request for a new dummy bearer as defined in EN 300 175-3 [3] subclause 9.3.2.

## 10.3 Downlink broadcast

The procedure shall be performed as defined in EN 300 175-3 [3] subclause 9.1.1.

### 10.3.1 $N_T$ messages

The FT shall be capable of sending and the PT shall be capable of receiving and processing the  $N_T$  message as defined in EN 300 175-3 [3] subclause 7.2.2, with contents as defined in table 12.

**Table 12: Values used within  $N_T$  message**

MAC message/broadcast element	Field within the message/broadcast element	Standard values within the MAC message	Normative action/comment
<<RFPI>>			
	<E-bit>	0	No SARI.
		1	SARI available. Relates to service SARI support.
	<PARI>	All	
	<RPN>	All	

## 10.3.2 Q<sub>T</sub> messages

### 10.3.2.1 Q<sub>T</sub> - static system information

The FT shall be capable of sending and the PT shall be capable of receiving and processing the Q<sub>T</sub> static system information message as defined in EN 300 175-3 [3] subclause 7.2.3.2, with contents as defined below.

**Table 13: Values used within static system info**

MAC message	Field within the message	Standard values within the MAC message	Normative action/comment
<<Static system info>>			
	<Q <sub>H</sub> >	0	
	<NR>	0, 1	PT shall support all values in order to gain lock. Asymmetric connections are not required to be supported by the PT.
	<SN>	0 to 11	PT shall support all values.
	<SP>	0	PT shall support all values in order to gain lock. Half slot connections are not required to be supported by the PT.
	<ESC>	0, 1	PT may ignore and assume the value to be 0.
	<Txs>	0 to 3	PT may ignore and assume the value to be 0.
	<Ext-car>	0, 1	PT shall support all values in order to keep in synchronization with the primary scan.
	<RF-car>	1 to 1 023	The PT shall not use carriers, which are not supported.
	<SPR>	0	PT may ignore.
	<CN>	0 to 9, 10 to 32	PT shall support normal values, and extended frequencies. The PT is not required to support transmission/reception on the extended frequencies.
	<SPR>	0	PT may ignore.
	<PSCN>	0 to 9, 10 to 32	PT shall support normal values, PT may be not able to transmit on any of the extended frequencies, however it shall be able to calculate the exact position of the PSCN based on all indicated to be supported by the FT carriers.

In case the <Ext-car> bit is set to 1, the RFP shall also broadcast the extended RF carrier information message as defined in EN 300 175-3 [3] subclause 7.2.3.3, where the fields are allowed the following values:

**Table 14: Values used within extended RF carrier info**

MAC message	Field within the message	Standard values within the MAC message	Normative action/comment
<<Extended RF carrier information>>			
	<Q <sub>H</sub> >	2	
	<RF carriers>	A12 - a34: {0, 1}	These bits may be set to indicate support for carriers 10-32
	<RF band>	All relevant	For values see physical layer spec
	<SPR>	0	PT may ignore
	<Nr of RF carriers>	all	

### 10.3.2.2 $Q_T$ - FP capabilities

#### 10.3.2.2.1 Standard FP Capabilities

The FP shall indicate its standard capabilities using the fixed part capabilities  $Q_T$  message as described EN 300 175-3 [3] subclause 7.2.3.4, with contents as defined below. The PT shall be able to receive and understand this message.

**Table 15: Values used within Standard FP capabilities**

MAC message	Field within the message	Standard values within the MAC message	Normative action/comment
<<FP capabilities>>			
	< $Q_H$ >	3	
	<a12>	1	Extended FP info ( $Q_H = 4$ )
	<a17>	1	Full slot
	<a19>	[0, 1]	low duty cycle Idle_Locked mode allowed
	<a21>	[0, 1]	C/L uplink, relates to and Distributed communication
	<a22>	[0, 1]	C/L downlink, relates to procedure Dynamic Parameter Allocation, subclause 12.9, SI <sub>P</sub> service and Distributed communication
	<a25>	1	B-field set-up
	<a26>	[0, 1]	C <sub>F</sub> messages, if PT supports only C <sub>S</sub> messages it may ignore this value
	<a29>	1	lp_error_detect
	<a30>	[0, 1]	lp_error_correction, if PT supports only lp_error_detect it may ignore this value
	<a31>	[0, 1]	Multibearer connections

#### 10.3.2.2.2 Extended FP Capabilities

The FP shall indicate its extended capabilities using the Extended fixed part capabilities  $Q_T$  message as described in EN 300 175-3 [3] subclause 7.2.3.5, with contents as defined below. The PT shall be able to receive and understand this message.

**Table 16: Values used within Extended FP capabilities**

MAC message	Field within the message	Standard values within the MAC message	Normative action/comment
<<FP capabilities>>			
	< $Q_H$ >	4	
	<a21>	1	MAC suspend and resume procedure supported.
	<a41>	[0, 1]	Asymmetric connection supported, the PT may ignore this value if it does not support asymmetric connections.
	<a45>	[0, 1]	DPRS stream support (see note).
	<a46>	[0, 1]	DPRS FREL support (see note).
NOTE: At least one of these bits shall be 1.			

## 10.3.2.3 Multiframe number

Table 17: Values used within  $Q_T$  multiframe number message

MAC message	Field within the message	Standard values within the MAC message	Normative action/comment
<<multiframe number>>			
	<Q header>	6	
	<spare>	111100001111b	
	<multi frame number>	All	The number of the multiframe, modulo $2^{**}24$ .

10.3.2.4  $Q_T$  - SARI list contents

The FT may send and the PT shall be capable of receiving and processing (if broadcast by the FT) the  $Q_T$  SARI message as defined in EN 300 175-3 [3] subclause 7.2.3.6, with contents as defined below.

This is relevant if the NT message indicates SARI support.

Table 18: Values used within SARI list contents

MAC message	Field within the message	Standard values within the MAC message	Normative action/comment
<<SARI list contents>>			
	< $Q_H$ >	5	
	<SARI list length>	All	
	<TARIs yes/no>	All	The PP may ignore it if Tertiary Access Rights Identity (TARI) request is not supported (support of TARI is not required).
	<Black yes/no>	All	The PP shall be able of distinguishing ARI from black ARI even if TARI is not supported.
	<ARI or black-ARI>	All	

## 10.4 Paging broadcast

### 10.4.1 Paging message formats

The FT and PT shall support the following paging message formats as defined in EN 300 175-3 [3] subclause 7.2.4.1 and subclause D.1.2 (for MAC resume paging message):

#### 10.4.1.1 Long or full page message format

**Table 19: Values used within long and full page message format**

MAC message	Field within the message	Standard values within the MAC message	Normative action/comment
<<Pt long page format>> or <<Pt full page format>>			
	<Pt-header extend flag > (a8)	0,1	a8 = 1 means another page message shall start in the next frame in this multiframe that is permitted to contain a Pt type.
	<BS SDU length indication> (a9 - a11)		
		010	full page message shall be used to carry LCE resume page message.
		100	not the last 36 bits of a long page (see note).
		101	the first 36 bits of a long page (see note).
		110	the last 36 bits of a long page (see note).
		111	all of a long page (first and last) (see note).
	<BS-channel data> (a12 - a47)	All	The content of the BS-channel data is defined by the LCE-message definition.

NOTE: Long page message format shall be used to carry CLMS-fixed - channel data - otherwise not applicable.

## 10.4.1.2 short page message format

Table 20: Values used within short page message format

MAC message	Field within the message	Standard values within the MAC message	Normative action/comment
<<Pt short page format>>			
	<Pt-header extend flag > (a8)	0,1	a8 = 1 means another page message shall start in the next frame in this multiframe that is permitted to contain a Pt type.
	<BS SDU length indication> (a9 - a11)	001	short page message.
	<BS-channel data> (a12 - a31)	All	The content of the BS-channel data is defined by the LCE-message definition.
	<MAC info type>(a32 - a35)	Various	The definition of MAC layer information to be supported is done by subclause 10.4.2.
	<MAC information> (a36 - a47)	Various	The definition of MAC layer information to be supported is done by subclause 10.4.2.

## 10.4.1.3 Zero length page message format

Table 21: Values used within zero length page message format

MAC message	Field within the message	Standard values within the MAC message	Normative action/comment
<<Pt zero length page format>>			
	<Pt-header extend flag > (a8)	0,1	a8 = 1 means another page message shall start in the next frame in this multiframe that is permitted to contain a Pt type.
	<BS SDU length indication> (a9 - a11)	000	Zero length page message.
	<20 LSBits of RFPI> (a12 - a31)	All	
	<MAC info type>(a32 - a35)	Various	The definition of MAC layer information to be supported is done by subclause 10.4.2.
	<MAC information> (a36 - a47)	Various	The definition of MAC layer information to be supported is done by subclause 10.4.2.

#### 10.4.1.4 MAC resume page message format

**Table 22: Values used within MAC resume page message format**

MAC message	Field within the message2	Standard values within the MAC message	Normative action/comment
<<Pt MAC resume page format>>			
	<Pt-header extend flag > (a8)	0,1	a8 = 1 means another page message shall start in the next frame in this multiframe that is permitted to contain a Pt type.
	<BS SDU length indication> (a9 - a11)	011	MAC resume page.
	<PMID>(a12 - a31)	All	PMID.
	<ECN> (a32-a35)	All	Exchanged connection number.
	(a36 - a47)	1111 1111 1111	Reserved.

#### 10.4.2 MAC layer information in zero and short length paging messages

The following MAC layer information types defined by EN 300 175-3 [3] subclause 7.2.4.3 shall be supported (understood) by a PT:

**Table 23: Types of MAC layer paging information to be supported by a PT**

a32	a33	a34	a35	MAC information type
0	0	0	1	blind slot information
0	0	1	0	other bearer
0	0	1	1	Recommended other bearer
0	1	0	1	dummy or C/L bearer position
1	1	0	0	C/L bearer position
1	0	0	1	bearer handover information
1	0	1	0	RFP-status. The procedure how to react on RFP-status "RFP-busy-for-data" is defined by subclause 9.3.2.1.2.

#### 10.4.3 FP paging procedure

The procedure shall be performed as defined by EN 300 175-3 [3] subclause 9.1.3.1.

The FP shall support normal paging and fast paging procedure as defined by EN 300 175-3 [3] subclause 9.1.3.1. Additionally FP shall support normal and fast paging for MAC resume page in the same way as for full page message format.

The support of low-duty-cycle-mode by page repetition is optional for the FP.

#### 10.4.4 PP paging procedure (Detection of paging message in idle locked mode)

The procedure shall be performed as defined by EN 300 175-3 [3] subclause 9.1.3.2.

If the PP supports fast paging procedure by usage of the high-duty-cycle-mode it shall announce that to the FP by the usage of the <<setup capabilities>> - IE as defined by subclause 12.11.



## 10.5 Logical Connection Setup

Logical Connection Setup is the procedure of creation of MBC. This procedure is immediately followed by a Physical connection setup.

The creation of an MBC is defined by EN 300 175-3 [3], subclause 10.2.4.1.

Physical Connection setup is defined by subclause 10.8.

## 10.6 Logical Connection Release

Logical Connection Release is the procedure of removal of an MBC. This procedure is preceded by either a NWK layer release procedure or by a handshake failure.

The NWK layer release procedure will cause DLC layer to send a MAC\_DIS\_req primitive to MBC.

The handshake procedure as defined in subclause 9.4.2.3 will cause the ME to send a MAC\_DIS\_req primitive.

Logical connection release will also cause Physical Connection release as defined in subclause 10.9.

## 10.7 Connection Modification

The only connection modification procedure that shall be supported is the change of bandwidth. This is defined by EN 300 175-3 [3], subclause 10.3.1.

The procedure shall be used in the following three cases:

- as part of the setup of a multibearer connection;
- modification of the bandwidth of an existing connection;
- release of a Physical Connection (i.e. suspend, modify to zero bandwidth).

The connection modification procedure consists of two phases:

- bandwidth negotiation;
- bandwidth modification.

### 10.7.1 Bandwidth negotiation

The following describes the negotiation, initiating side may be FT or PT.

The initiating side shall indicate the bandwidth request by means of a BANDWIDTH.req message. The receiving side shall reply to this with a BANDWIDTH.cfm message. The bandwidth indicated by the BANDWIDTH.cfm message is the negotiated bandwidth.

In case of call setup, a bandwidth negotiation procedure shall be initiated by the call originating side.

In case of resume, a bandwidth negotiation procedure shall be initiated by the side which initiated the resume.

For FT-initiated bandwidth-negotiation the negotiated values shall be equal to those requested by the initiating side, if these values are within the range configured or negotiated at NWK level.

For PT-initiated bandwidth-negotiation the negotiated values shall be those indicated by the FT. These values shall be within the range configured or negotiated at NWK level.

If the requested values are outside the range configured or negotiated NWK level, then the negotiated values shall be equal to the values before the request. This means a rejection of the bandwidth request.

As the FT is the master side, controlling the bandwidth, the rules for rejecting a bandwidth request are different for FT and PT:

- Rejection of the FT requested bandwidth by the PT can only happen under conditions defined in subclause 9.3.1.3.1. Rejection of the FT requested bandwidth equal to 0 by the PT (suspension) can only happen under conditions defined in subclause 9.3.1.2.1.
- Rejection of the PT requested bandwidth by the FT is always allowed.

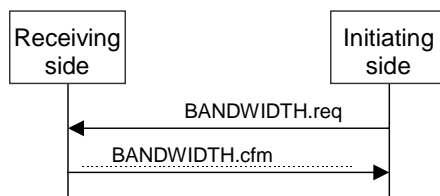

**Figure 2: FT initiated bandwidth modification**

In order to improve efficiency of bandwidth usage, it shall be allowed to use the BANDWIDTH\_T messages instead of the BANDWIDTH\_B messages, wherever appropriate, but the bandwidth-confirm shall be send as the same type of message as the request.

The following fields as defined in EN 300 175-3 [3] subclause 7.2.5.3.9 of the BANDWIDTH\_T request and confirm messages shall be supported by the PT and the FT.

**Table 24: Values used within BANDWIDTH\_T message**

MAC message	Field within the message	Standard values within the MAC message	Normative action/comment
<<M <sub>T</sub> message>>			
	<M <sub>T</sub> header>	0001	"Advanced connection control".
	<Command>	8	"Bandwidth_T.request"
		9	"Bandwidth_T.confirm"
	<FMID>	All	
	<Mup, Mdown, Tup, Tdown>	0, 1 to 23	bandwidth values (see note 1 and 2)
NOTE 1: The bandwidth value 0 is used in these messages to initiate a connection suspension, or in some cases of rejection. Otherwise the bandwidth values shall be within the limits configured (mobility class 1) or negotiated at call setup (mobility class 2).			
NOTE 2: In case of a connection setup due to the handshake procedure, the bandwidth is immediately negotiated to 0, and the pilot bearer released.			

The following fields as defined in EN 300 175-3 [3] subclause 7.3.2.6 of the BANDWIDTH\_B request and confirm messages shall be supported by the PT and the FT.

**Table 25: Values used within BANDWIDTH\_B message**

MAC message	Field within the message	Standard values within the MAC message	Normative action/comment
<<M <sub>Bn</sub> message>>			
	<M <sub>Bn</sub> header>	X001	"Advanced connection control".
	<Command>	8	"Bandwidth_B.request"
		9	"Bandwidth_B.confirm"
	<FMID>	All	
	<Mup, Mdown, Tup, Tdown>	0, 1 to 23	bandwidth values (see note 1 and 2)
NOTE 1: The bandwidth value 0 is used in these messages to initiate a connection suspension, or in some cases of rejection. Otherwise the bandwidth values shall be within the limits configured (mobility class 1) or negotiated at call setup (mobility class 2).			
NOTE 2: In case of a connection setup due to the handshake procedure, the bandwidth is immediately negotiated to 0, and the pilot bearer released.			

## 10.7.2 Bandwidth modification

Depending on the actual situation, different procedures can be used to modify the bandwidth of a connection. To add additional duplex bearers, the single duplex bearer setup procedure shall be used as defined in subclause 10.10.1. To add additional simplex bearers, the double simplex bearer setup procedure shall be used as defined in subclause 10.10.2. To release bearers, the unacknowledged bearer release procedure shall be used as defined in subclause 10.11.1. To reverse double simplex bearers, the fast release procedure shall be used as defined in subclause 10.11.3.

The procedures are symmetric, and for the description below the following definition holds:

**Table 26: Master/Slave definition**

current connection	Modified connection	PT	FT
n.a.	Asymmetric uplink	Master	slave
n.a.	Symmetric	Master	slave
n.a.	Asymmetric downlink	Slave	master
asymmetric uplink	Suspended	Slave	master
Symmetric	Suspended	Slave	master

The order of actions to be performed is as follows:

- release by the slave of any surplus double simplex bearers in the direction slave to master, by either the unacknowledged or fast release procedure;
- release by the master of any surplus bearer;
- set-up by the master of any additional bearer.

## 10.7.3 Suspend

The suspend procedure is a special case of bandwidth modification, with negotiated value equal zero.

Additional situations will also lead to a suspend, without prior exchange of bandwidth negotiation messages:

- loss of all bearers of a connection;
- loss of the last duplex bearer, controlling the connection;
- violation of bandwidth, see subclause 9.3.1.2.3.

In these additional situations, the bandwidth modification is immediately performed.

## 10.7.4 Resume

Resumption is the procedure to leave the suspend state by setting up a pilot duplex bearer, followed by bandwidth modification when necessary. Management Entity will trigger this procedure as defined in subclauses 9.3.1.1 and 9.3.2.1.

In case of a connection resumption in a different cluster than where the connection was suspended, the PT will use the "connection\_handover\_request" rather than the "access\_request" type of bearer request message.

## 10.8 Physical Connection Setup

The MBC will establish a Physical Connection upon request of the ME. It either can be a single bearer Physical Connection or a multibearer Physical Connection.

### 10.8.1 Single bearer physical connection setup

The procedure of single bearer Physical Connection setup shall be performed as defined by EN 300 175-3 [3], subclause 10.2.4.2. Only B-field advanced single bearer setup procedure shall be used (refer to subclause 10.10.1).

## 10.8.2 Multibearer Physical Connection setup

The procedure of multibearer Physical Connection setup shall be performed as defined by EN 300 175-3 [3], subclause 10.2.4.3. Only B-field advanced single bearer setup procedure shall be used for duplex bearer setup (refer to subclause 10.10.1). For creation of double simplex bearers in case of asymmetric connections the B-field advanced double simplex bearer setup procedure shall be used (refer to subclause 10.10.2).

## 10.9 Physical Connection Release

Physical Connection release is the procedure to release all bearers associated to a logical connection (subclause 10.11).

## 10.10 Bearer Setup

### 10.10.1 Single duplex bearer setup

This procedure shall be performed as defined in EN 300 175-3 [3] subclause 10.5.1.3, taking into account the additions defined in the following subclauses. A single duplex bearer setup can either be a pilot bearer setup or a setup of an additional duplex bearer.

The following fields as defined in EN 300 175-3 [3] subclause 7.3.2 of the BEARER\_REQUEST and BEARER\_CONFIRM and WAIT messages shall be supported by the PT and the FT.

**Table 27: Values used within Advanced Connection Control messages during duplex bearer**

MAC message	Field within the message	Standard values within the MAC message	Normative action/comment
<<MBn message>>			
	<MBn header>	X001	"Advanced connection control".
	<Command>	0	"Access_request"
		1	"Bearer handover request" (optional)
		2	"Connection_handover_request" (optional)
		3	Unconfirmed access request (see note 3)
		4	"Bearer_confirm"
		5	"Wait"
		12	Unconfirmed handover (see note 3)
	<FMID>	All	
	<PMID>	All	
	<ECN>	All	(see note 1)
	<LBN>	1 - 15	The value 15 is reserved for the pilot bearer (see note 1)
	<up/down/ss/sm>	All	Connection type; (see note 1 and 2)
	<service type>	2	I <sub>p</sub> -error -detect (see note 1)
		3	I <sub>p</sub> error correct (optional); (see note 1)
	<max. lifetime>	0-7	(see note 1) if only I <sub>p</sub> error detect is supported, this value may be ignored
	<slot type>	0	Full slot (see note 1)
NOTE 1: For command values 0, 1, 2 and 4 only.			
NOTE 2: In case of "up", "down" or "sm", the eventual character of a multibearer connection will be determined during bandwidth negotiation phase.			
NOTE 3: Only for double simplex bearer setup procedures.			

### 10.10.1.1 PT initiated Single duplex bearer setup

This procedure shall be performed as defined by EN 300 175-3 [3], subclause 10.5.1.3.1.

Optionally, a number of WAIT messages may be exchanged.

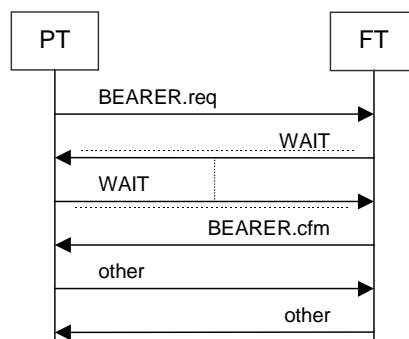

**Figure 3: PT initiated setup of single duplex bearer**

**NOTE:** In case of a multi bearer connection the "other" messages may be replaced by the BANDWIDTH request/confirm, described in the connection modification procedure.

### 10.10.1.2 FT initiated Single duplex bearer setup

This procedure shall be performed as defined by EN 300 175-3 [3], subclause 10.5.1.3.2.

The FT initiated connection setup is also referred to as fast setup. The only bearer-request message allowed in this case is the access-request. Optionally a number of WAIT messages may be exchanged.

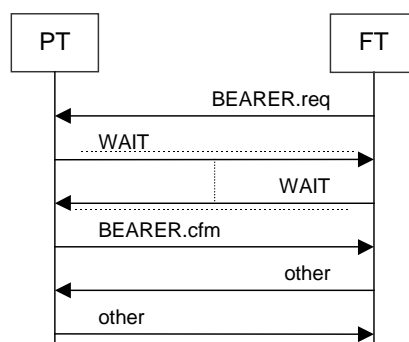

**Figure 4: FT initiated setup of pilot bearer (fast setup)**

**NOTE:** In case of a multi bearer connection the "other" messages may be replaced by the BANDWIDTH request/confirm, described in the connection modification procedure.

### 10.10.1.3 Usage of channel list messages for single duplex bearer setup

The following fields of the CHANNEL\_LIST message as defined in EN 300 175-3 [3] subclauses 7.3.2.7 and 10.5.2 shall be understood by the receiving side and taken into account for channel selection as defined by EN 300 175-3 [3], subclauses 11.4.2 and 11.4.3:

**Table 28: Values used within the MB CHANNEL\_LIST message**

MAC message	Field within the message	Standard values within the MAC message	Normative action/comment
<<MBn message>>			
	<MBnheader>	X001	"Advanced connection control".
	<Command>	10	"Channel_list"
	<RPN>	All	
	<Command>	001	GOOD
	S/D	All	
	SN	0-11	
	SP	0	
	CN	0-9	

### 10.10.2 Double simplex bearer setup

The procedure is defined by EN 300 175-3 [3], subclause 10.5.1.4.

The direct double simplex bearer setup shall be supported.

In case the R-side wants to select a channel it shall use either the GOOD or the LISTEN channel list message.

NOTE 1: The LISTEN message requires a deviation from the scanning sequence on the selected slots, the GOOD message allows channel selection with unmodified scanning.

The direct double simplex bearer setup procedure is defined by EN 300 175-3 [3], subclause 10.5.1.4. Only B-field direct bearer setup procedure shall be used.

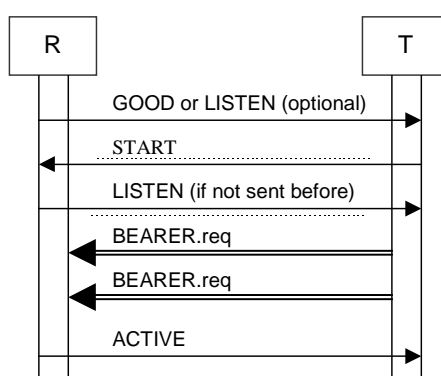

**Figure 5: Successful direct double simplex bearer setup**

NOTE 2: Each side has a line for the duplex bearer and a line for the double simplex bearer. All channel list messages should be sent at the same duplex bearer.

The following fields of the CHANNEL\_LIST message as defined in EN 300 175-3 [3] subclauses 7.3.2.7 and 10.5.2 shall be understood by the receiving side and taken into account for channel selection as defined by EN 300 175-3 [3] subclauses 11.4.2 and 11.4.3:

**Table 29: Values used within the MB CHANNEL\_LIST message**

MAC message	Field within the message	Standard values within the MAC message	Normative action/comment
<<MBn message>>			
	<MBnheader>	X001	"Advanced connection control".
	<Command>	10	"Channel_list"
	<RPN>	All	
	<Command>	000 110 111	ACTIVE LISTEN START Other messages may be send
	S/D	All	
	SN	0 to 11	
	SP	0	
	CN	0 to 9	

NOTE 3: The channel list messages GOOD and POOR should be used to improve the response time of the procedure.

## 10.11 Bearer Release

The following fields of the RELEASE message as defined in EN 300 175-3 [3] subclause 7.3.3.10 shall be supported by the PT and the FT.

**Table 30: Values used within MBn RELEASE message**

MAC message	Field within the message	Standard values within the MAC message	Normative action/comment
<<MBn message>>			
	<MBn header>	X001	"Advanced connection control".
	<Command>	15	"Release"
	<FMID>	All	
	<PMID>	All	
	<LBN>	All	
	<reason>	1 2 3 4 11	Bearer release Connection release (see note 1) Bearer setup or HO failed (see note 2) BHO successfully completed (see note 2) Reversal
NOTE 1: The connection release reason shall only be used during logical connection release.			
NOTE 2: Only used when double simplex bearer handover is supported.			

### 10.11.1 Unacknowledged release

To release a duplex or a double simplex bearer with the unacknowledged release procedure, the transmitting side sends a RELEASE message with reason "bearer release" or "connection release" in two consecutive frames, and then immediately seizes all transmission on this bearer. This is defined in EN 300 175-3 [3] subclause 10.7.2.1.

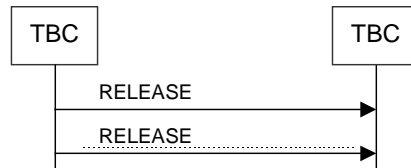

**Figure 6: Unacknowledged release**

### 10.11.2 Acknowledged release

To release a double simplex bearer with the acknowledged release procedure, the receiving side sends a RELEASE message with reason "bearer release" via any bearer in the reverse direction. This is defined in EN 300 175-3 [3], subclause 10.7.2.2.

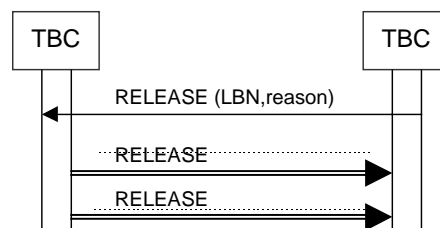

**Figure 7: Acknowledged release**

### 10.11.3 Fast release

To reverse the transmission direction on a double simplex bearer with the fast release procedure, the transmitting side sends a RELEASE message with the reason field set to "reversal" on both simplex bearers, and starts scanning on both released simplex bearers for the next 4 frames. The receiver of the RELEASE message may use the released bearer to set up a double simplex bearer into the other direction, using the normal double simplex bearer setup procedure. This is defined in EN 300 175-3 [3] subclause 10.7.2.3.

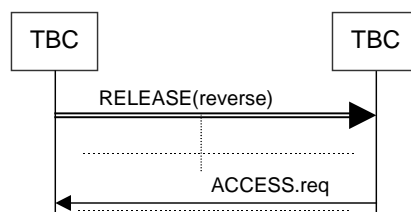

**Figure 8: Fast release**

## 10.12 Advanced connection handover

The procedure shall be performed as defined in subclause 10.5. This procedure will be used only for intercell connection handover, anyhow the procedure is equivalent for intra- and inter-cell handover.

For connection handover in the case of resumption: see subclause 10.7 of the present document.

Before starting the CHO the bandwidth of the old connection may be reduced to the minimum to allow a higher amount of selectable bearers for the new connection.



## 10.13 I-channel operation

### 10.13.1 I<sub>P</sub>-error-detect mode

The FT and PT shall support protected I-channel operation in error-detect mode as defined in EN 300 175-3 [3], subclause 10.8.1.3.

### 10.13.2 I<sub>P</sub>-error-correct mode

The FT and PT shall support protected I-channel operation in error-correct mode as defined in EN 300 175-3 [3], subclause 10.8.2.

#### 10.13.2.1 Unilateral jump

FT and PT shall support unilateral data jump procedure according to subclause D.1.4.4.3 (EN 300 175-3 [3], subclause 10.8.2.5.2).

#### 10.13.2.2 Bearer reset

FT and PT shall support bearer reset according to EN 300 175-3 [3] subclause 10.8.2.5.3.

### 10.13.3 Connectionless SI<sub>P</sub> mode

The SI<sub>P</sub> service uses the connectionless downlink procedure as defined by EN 300 175-3 [3] subclause 9.1.2. The following text together with the associated subclauses define the mandatory requirements with regard to the present document.

The SI<sub>P</sub> protected data connectionless downlink service is used by the FP-PP point-to-multipoint service to transfer the data frames, after the LU10 framing and FU10a segmentation functions have been performed on the point-to-multipoint SDU (see clause 11).

The FP shall only transmit SI<sub>P</sub> data starting at the start of a paging cycle. A PP shall understand the presence of SI<sub>P</sub> data to be indicated by the coding BA = SI<sub>P</sub>.

The connectionless downlink bearer used to carry the SI<sub>P</sub> service shall be announced by the PT MAC layer information = "Dummy or C/L bearer" or "C/L bearer position".

A connectionless bearer is marked as a connectionless bearer by the value of the TA-bits = 010.

The TDMA frame immediately following the frame in which SI<sub>P</sub> data was received shall also be monitored to find out whether it contains SI<sub>P</sub> data.

In this way SI<sub>P</sub> data shall be understood to be present in each subsequent TDMA frame until the BA and MAC layer information codings indicate that the SI<sub>P</sub> data field is no longer present. No further SI<sub>P</sub> information shall then be available until the start of the next paging cycle.

The start of a paging cycle in this context shall be that time-slot in frame 0 of a multiframe that is carrying the start of a paging message. When paging repetition is supported by the fixed part, the modulo 4 of the number of this multiframe shall be 0.

PPs in low\_duty\_cycle mode shall listen to frames where the modulo 4 of the number of the multiframe is 0.

New connectionless downlink bearers shall be announced by the FP by broadcast of the PT MAC layer information = "Dummy or C/L bearer" or "C/L bearer position" at least one multiframe or 4 multiframe if low\_duty\_cycle\_mode is allowed at this FP in advance of the first transmission of SI<sub>P</sub> data.

## 10.14 C-channel operation

### 10.14.1 C<sub>S</sub>-channel

FT and PT shall support C<sub>S</sub>-channel data transmission and reception as defined in EN 300 175-3 [3] subclauses 10.8.1 and 10.8.1.1.

### 10.14.2 C<sub>F</sub>-channel

FT and PT shall support C<sub>F</sub>-channel data transmission and reception as defined in EN 300 175-3 [3] subclauses 10.8.1 and 10.8.1.2.

## 10.15 Encryption

### 10.15.1 Encryption process - initialization and synchronization

The procedure shall use DSCA and shall be performed as defined in EN 300 175-7 [7] subclauses 6.4.4 and 6.4.5. Encryption shall be applied to each of the logical C, I, and G<sub>F</sub>-channels.

If encryption is provided by the FT, the FT shall support broadcast of multiframe number as defined in EN 300 175-3 [3] subclauses 7.2.3.7 and 9.1.1. The multiframenumber shall be synchronized between the RFPs in the whole internal handover area.

### 10.15.2 Encryption mode control

The procedure shall be performed as defined in EN 300 175-7 [7] subclause 6.4.6.

#### 10.15.2.1 M<sub>T</sub> message

The following fields as defined in EN 300 175-3 [3] subclause 7.2.5.7 in the MAC control (M<sub>T</sub>) message shall be supported by the PT and the FT.

**Table 31: Values used within M<sub>T</sub> message**

MAC message	Field within the message	Standard values within the MAC message	Normative action/comment
<<M <sub>T</sub> message>>			
	<M <sub>T</sub> header>	5	Encryption control.
	<Command>	0	Start Encryption Request
		1	Start Encryption Confirm
		2	Start Encryption Grant
		4	Stop Encryption Request. (see note)
		5	Stop Encryption Confirm. (see note)
		6	Stop Encryption Grant. (see note)
NOTE: These commands are only required if encryption deactivation is supported.			

#### 10.15.2.2 PT procedure for enabling encryption

If the PT-MAC receives a MAC\_ENC\_EKS-req primitive then it shall start the encryption switching process on one bearer as described in EN 300 175-7 [7] subclause 6.4.6.3. In case of a multi-bearer connection, all other bearers of the connection shall switch to encrypted mode at the same time as the bearer performing the single bearer encryption mode procedure.

Additional bearers that are setup after the connection has switched to encrypt mode shall switch to encryption mode immediately after the bearer has been established.

### 10.15.2.3 PT procedure for disabling encryption

If the PT-MAC receives a MAC\_ENC\_EKS-req primitive then it shall start the encryption switching process on one bearer as described in EN 300 175-7 [7] subclause 6.4.6.4. In case of a multi-bearer connection, all other bearers of the connection shall switch to clear mode at the same time as the bearer performing the single bearer encryption mode procedure.

### 10.15.3 Handover encryption process

The procedure shall be performed as described in EN 300 175-7 [7] subclause 6.4.7.

The additional bearers of the new multibearer connection shall switch to encrypted at the same time as the bearer performing the single bearer encryption mode procedure.

## 10.16 Quality control

### 10.16.1 RFPI handshake

RFPI handshake procedure shall be performed as defined in EN 300 175-3 [3], subclause 11.5.1.

### 10.16.2 PT frequency correction

PT frequency correction procedure shall be performed as defined in EN 300 175-3 [3], subclause 11.5.2.2.

### 10.16.3 Bearer quality report

Receiver side will send bits Q1 and Q2 reporting quality of received bearers. Report shall be done in bits a3 and a7 of A field in the reverse bearer in case of duplex bearers, or using the MAC-mod2-ACK message, defined in D.1.4.1 (EN 300 175-3 [3], subclause 7.3.4.4) in double simplex bearers. In Ip\_error\_correct, bit BCK shall be send in the place of Q1.

The bit Q1 shall be set as defined in EN 300 175-3 [3], subclause 10.8.1.3.2. The use of bit Q1 is optional. The bit Q2 shall be set as described in D.1.4.3, subclause 10.8.1.3.1).

FT and PT should use the information of the received bits Q1 and Q2 to take the decision to perform bearer replacement procedures.

FT may use the information of the Q1 and Q2-bits sent by the PT, to decide whether to switch antenna or not.

By negotiation it is possible to avoid the insertion of the message in all frames, or to suppress the message. In this case the procedure described in subclause 10.16.4 shall be used for quality control purposes.

The negotiation is performed as described in subclause 12.9.

In absence of negotiation the report shall be send in all frames.

## 10.16.4 Bearer and connection control

PT and FT shall use the "Bearer and connection control" message (subclause D.1.3 - EN 300 175-3 [3], subclause 7.3.4.2) to request the other side to perform antenna switch, bearer replacement or bearer handover. Requests for bearer handover may be understood as requests for bearer replacements or bearer handover in DPRS.

**Table 32: Values used within Bearer and Connection Control messages.**

MAC message	Field within the message	Standard values within the MAC message	Normative action/comment
<<MBn message>>			
	<MBn header>	X011	"Quality Control".
	<Command>	0000-1001	"Bearer and Connection Control"
	<FMID>	All	
	<PMID>	All	
	<param_1>	All	
	<param_2>	All	
	<spare>	0000 1111	

## 10.16.5 A-CRC handshake

If no correct A-CRC has been received during a time of T908, the bearer shall be released. Duplex bearers shall use the unacknowledged bearer release procedure defined in subclause 10.11.1. Double simplex bearers receiving side shall use the acknowledged bearer release procedure as defined in subclause 10.11.2.

NOTE: The normal reaction on the release of a bearer because of A-CRC handshake failure will be a bearer replacement. In case of release of all bearers the suspend-state will be entered.

## 10.17 Physical channel selection

The selection of a physical channel for a new bearer shall be performed according to the requirements in EN 300 175-3 [3], subclause 11.4. The selection procedure for additional bearers in a multibearer connection shall also take into account the channellist procedures as defined in EN 300 175-3 [3], subclause 10.5.2.

## 10.18 Bearer replacement

This procedure is the main way to improve the quality of a connection by changing bearers to different channels within the same cluster.

"Bearer replacement" is defined to be the procedure where an old bearer is replaced with a new bearer that has a different LBN or where the old bearer was lost before the new bearer is setup with the same LBN. The procedure to setup the new bearer is defined by subclause 10.10. The procedure to release the old bearer is defined in subclause 10.11.

For replacement of one bearer of an Ip-error-protected connection the procedure is defined in EN 300 175-3 [3] subclause 10.8.2.5.1.

NOTE: The timer T906 guards the time the amount of bearers is less than the minimum.

It is preferred to first drop the old bearer and then set-up the new bearer, or to do this simultaneously. It is not required to have the new bearer active before the old bearer is released.

## 10.19 Bearer handover request

The procedure shall be performed as defined in EN 300 175-3 [3], subclauses 10.6.2 and 10.6.3. The B-field procedures shall be supported. The bearer setup procedures are defined by subclause 10.10 and the bearer release procedure is defined by subclause 10.11.1.

The procedure is equivalent for intra- and inter-cell handover.

The FT should not release the old bearer within 10 ms after the establishment of the new bearer.

## 10.20 G<sub>F</sub>-channel

### 10.20.1 G<sub>F</sub>-channel data

FT and PT shall support G<sub>F</sub>-channel data transmission and reception as defined in EN 300 175-3 [3] subclauses 7.3.6.

# 11 DLC layer procedures

## 11.1 LU10 Enhanced Frame RELay service (EFREL)

The procedure shall be performed as defined in EN 300 175-4 [4], subclause 11.12.1. The following text together with the associated subclauses define the mandatory requirements with regard to the present document.

The SDU shall be segmented into fixed length segments, where the segment length shall depend on the PDU structure chosen (subclause 11.2).

The MAC Ip\_error\_detection service shall be used. The MAC Ip\_error\_correction service can be negotiated by the network layer and replace the MAC Ip\_error\_detection service.

The transmission class 2 shall be used.

The selective retransmission protocol (SEL) shall be used.

Modulus shall be 512, i.e. the receive sequence number and the send sequence number has a default range from 0 to 511. If the window size  $\leq 128$  both peers shall ignore the 9th bit (ES9) of the sequence numbers.

### 11.1.1 Window size

The window size can be negotiated in the range of 1 to 256 by the NWK-layer.

The default value for the window size is 32.

This default value will be used in absence or failure of NWK-Layer negotiation.

Any DPRS device shall support at least the following values for the window size:

**Table 33: Window size data rates**

Minimum mandatory supported window size	Maximum Data rate supported (at the air i/f)
32	Up to 96 kbit/s
64	> 96 kbit/s to 200 kbit/s
128	> 200 kbit/s

Any PT or FT shall accept in a negotiation any value between the default (32) and the minimum mandatory supported window size.

## 11.1.2 U-plane transmission class 2

### 11.1.2.1 Sending side procedures

The procedure shall be performed as defined in D.2.5, subclause 14.3.4.1. The following text together with the associated subclauses define the mandatory requirements with regard to the present document.

The sequence numbers shall be added using the rules defined below.

If a connection oriented MAC service is used (see EN 300 175-3 [3], subclause 5.6), then the send sequence number shall be set to zero at the start of the MAC connection, and this value shall be used for the first transmitted frame over that MAC connection. The send sequence numbers of successive frames shall be contiguous (Modulus) during the lifetime of that MAC connection.

If a connectionless MAC service is used (see EN 300 175-3 [3], subclauses 5.7 and 9.1.2.2), then the send sequence number of the first segment of a DLC SDU may be arbitrarily chosen. The send sequence numbers of successive frames shall be contiguous (Modulus) within one DLC SDU.

At the transmitting side a complete SDU shall be received in a DL\_U\_DATA-req primitive. The SDU shall be passed to the segmenting function and segmented into an integral number of segments. The last segment shall be filled with fill octets if necessary. The information content of each PDU shall be marked using the length indicator as described in subclause D.2.4.

Several PDUs may be submitted once to the MAC layer in a single MAC\_CO\_DATA-req primitive in response to each MAC\_CO\_DTR-ind primitive. The number of PDUs shall be less than or equal to the maximum number requested in the MAC\_CO\_DTR-ind primitive.

### 11.1.2.2 Receiving side procedure

The procedure shall be performed as defined in D.2.5. The following text together with the associated subclauses defines the mandatory requirements with regard to the present document.

The receive sequence number shall be set to 0 at service establishment.

Several PDUs may be received from the MAC layer in a single MAC\_CO\_DATA-ind primitive. The receive side shall re-order the PDUs using the send sequence numbers. The receive side shall then search for SDU boundaries using the extended more bit as defined in subclause D.2.2.

A complete SDU shall be assumed to exist, and shall be passed to the IWU using a DL\_U\_DATA-ind primitive when the following conditions are satisfied:

- two successive boundaries have been identified using the extended More bit (i.e. there are no intermediate boundaries);
- PDUs have been successfully received for all of the sequence numbers that lie between those boundaries.

## 11.2 FU 10 framing (FU10a, FU10b, FU10c)

The procedure shall be performed as defined in subclause D.2.1. The following text together with the associated subclauses defines the mandatory requirements with regard to the present document.

### 11.2.1 FU10a

FU10a frames with total length of 32 octets shall be used for the forward path of the unidirectional link.

### 11.2.2 FU10b

FU10b frames with total length of 32 octets can only be used for bi-directional links and can only be used after negotiation by the network layer, see subclause 12.5.

### 11.2.3 FU10c

FU10c frames with total length of 7 octets shall be used for the backward control path.

## 11.3 Class A operation

The class A link operation can be either PT or FT initiated. To simplify the description this subclause considers on the PT initiated procedures; for the FT initiated procedures, "PT" shall be replaced with "FT" and vice versa. This is valid for the entire subclause 11.3 and the associated subclauses.

### 11.3.1 Class A link establishment

The procedure shall be performed as defined in EN 300 444 [8], subclause 9.1 except of subclause 9.1.1.4 which is replaced by subclause 11.2.1.1. The following text together with the associated subclauses defines the mandatory requirements with regard to the present document.

If class B acknowledged transfer is requested but not supported by the receiving side (B acknowledged transfer is not required to be supported for DPRS), the I\_frame requesting class B operation shall be treated as though it was a class A frame, see EN 300 175-4 [4], subclauses 9.2.4.3.1 and 9.2.4.3.2 b).

#### 11.3.1.1 Lower Layer Management Entity (LLME) establishment of a MAC connection.

The procedure shall be performed as defined in EN 300 175-4 [4] subclause 10.2 and EN 300 175-3 [3] subclause 8.1.1. The following text together with the associated subclauses defines the mandatory requirements with regard to the present document.

For a link to be established a suitable MAC connection is needed. If such one does not exist the LLME shall request it.

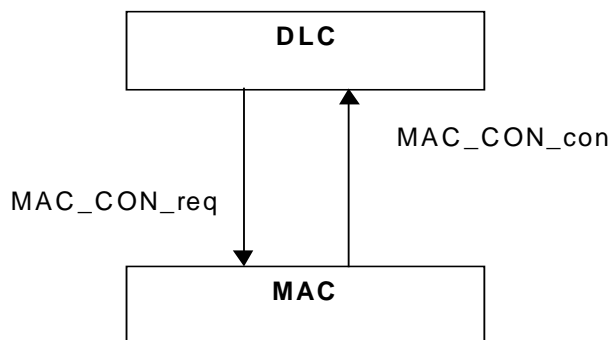

**Figure 9: Establishment of a MAC connection initiating side**

**Table 34: Values used within the MAC\_CON-req primitive**

Parameter	Information within the parameter	Normative action/comment
<<MCEI>>	MAC Connection Endpoint Identifier	Refer to EN 300 175-4 [4] subclause 10.2.4.4
<<PMID>>	Portable part MAC Identity (PMID)	
<<CHO flag>>	Y/N	Y - if the connection is required for Connection handover
<<Old MCEI>>	All relevant	Only needed for Connection handover and Basic type connections
<<C <sub>F</sub> required>>	0, 1	C <sub>F</sub> is optional
<<Slot type>>	Full slot	
<<Service type>>	Ip_error_detection	
	Ip_error_correction	optional
<<up/down/sm/ss>>	All relevant	
<<connection type>>	Advanced	

**Table 35: Values used within the MAC\_CON-cfm primitive**

Parameter	Information within the parameter	Normative action/comment
<<MCEI>>	MAC Connection Endpoint Identifier	Refer to EN 300 175-4 [4] subclause 10.2.4.4
<<Connection type>>	Advanced	The type of the established connection
<<ECN>>	All relevant	Refer to EN 300 175-4 [4] subclause 10.2.4.2

The receiving side shall be informed about the action that has taken place in case it was successful by a MAC\_CON-ind primitive.

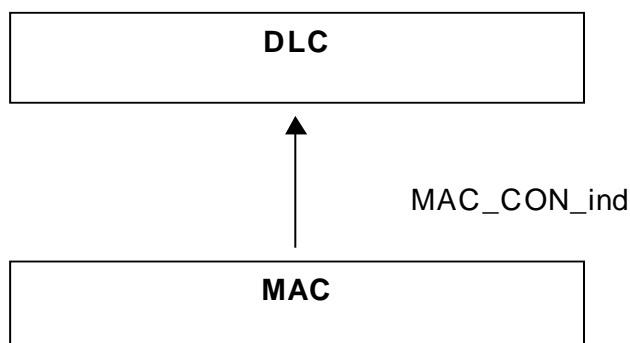
**Figure 10: Establishment of a MAC connection, receiving side**



**Table 36: Values used within the MAC\_CON-ind primitive**

Parameter	Information within the parameter	Normative action/comment
<<MCEI>>	MAC Connection Endpoint Identifier	Refer to EN 300 175-4 [4] subclause 10.2.4.4
<<PMID>>	PMID	
<<CHO flag>>	Y/N	Y - if the connection is required for Connection handover
<<C <sub>F</sub> required>>	0, 1	C <sub>F</sub> is optional
<<Slot type>>	Full slot	
<<Service type>>	Ip_error_detection	
	Ip_error_correction	Optional
<<up/down/sm/ss>>	All relevant	
<<Connection type>>	Advanced	
<<ECN>>	All relevant	Refer to EN 300 175-4 [4] subclause 10.2.4.2

The successful setup of the advanced connection may be followed by a connection modification, as defined in EN 300 175-4 [4] subclause 10.2.3, case B.

### 11.3.2 Class A acknowledged information transfer

The procedure shall be performed as defined in EN 300 444 [8], subclause 9.2.

### 11.3.3 Class A link release

The procedure shall be performed as defined in EN 300 444 [8], subclause 9.3.

### 11.3.4 Class A link re-establishment

The procedure shall be performed as defined in EN 300 444 [8], subclause 9.4.

## 11.4 Class U operation

For class U operation only the U-format is used in the control field defined in EN 300 175-4 [4], subclause 7.4, with contents as defined below.

**Table 37: Values used within DLC command**

DLC command	Field within the command	Standard values within the command	Normative action/comment
<<U-command>>			
	<U U U>	0 0 0	
	<P/F>	0	
	<U U>	0 0	
	1 1	1 1	

### 11.4.1 Class U use of LLN for unacknowledged information transfer

The procedure shall be performed as defined in EN 300 175-4 [4], subclause 9.3.1.

### 11.4.2 Class U link establishment

The procedure shall be performed as defined in EN 300 175-4 [4], subclause 9.3.2.

### 11.4.3 Class U unacknowledged information transfer

The procedure shall be performed as defined in EN 300 175-4 [4], subclause 9.3.3.

### 11.4.4 Class U unacknowledged release

The procedure shall be performed as defined in EN 300 175-4 [4], subclause 9.3.4.

## 11.5 Lc frame delimiting and sequencing service

### 11.5.1 C<sub>S</sub>-channel fragmentation and recombination

The procedure shall be performed as defined in EN 300 175-4 [4], subclauses 6.1.2, 6.1.3 and 6.1.4, 6.1.4.2. The following text together with the associated subclauses define the mandatory requirements with regard to the present document.

The complete frame shall be fragmented into 5 octet fragments.

### 11.5.2 C<sub>F</sub>-channel fragmentation and recombination

The C<sub>F</sub>-channel shall be operated according to the procedures defined in EN 300 175-4 [4] subclauses 6.1.2, 6.1.3, 6.1.4 and 6.1.4.1. The following text together with the associated subclauses define the mandatory requirements with regard to the present document.

The complete frame shall be fragmented into 8 octet fragments.

### 11.5.3 Selection of logical channels (C<sub>S</sub> and C<sub>F</sub>)

The selection of the C<sub>F</sub> instead of the C<sub>S</sub>-channel for Lc operation, shall be done according to the conditions defined in EN 300 175-4 [4], subclause 10.2.5.

## 11.6 Broadcast Lb service

### 11.6.1 Normal broadcast

The procedure shall be performed as defined in EN 300 175-4 [4], subclauses 6.2.1, 8.3.3.1, 9.4.1.1 and 9.4.1.2 and EN 300 175-3 [3], subclause 8.2.1. The following text together with the associated subclauses define the mandatory requirements with regard to the present document.

Short frame format (frame length = 3) and long frame format (frame length = 5) are required to be supported.

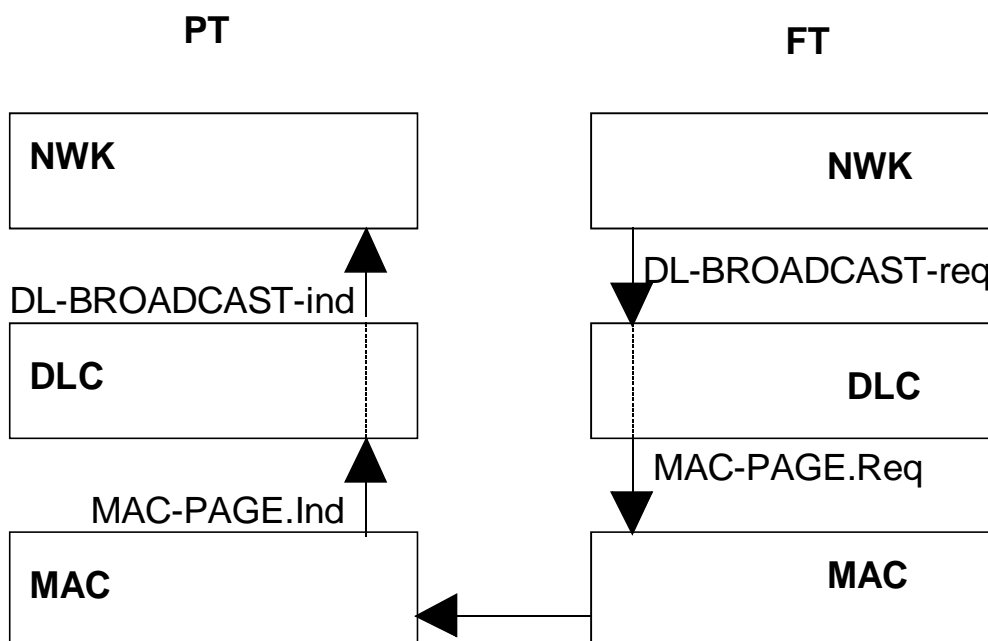

Figure 11: Normal broadcast

Table 38: Information used within the DL-BROADCAST-req primitive

Parameter	Information within the parameter	Normative action/comment
<<Cluster address list>>	all cluster/an integer	
<<Message unit length>>	3, 5 octets	Short and long frame format are required to be supported
<<Message unit>>	From the NWK layer	

Table 39: Information used within the MAC\_PAGE.Req primitive

Parameter	Information within the parameter	Normative action/comment
<<cluster ID>>	all clusters/an integer	
<<page type>>	normal	
<<length of page field>>	0, 20 or 36	
<<long flag>>	long	is only relevant if length of page field = 36
<<SDU>>	The data from the <<Message unit>> received in the DL-BROADCAST-req primitive	

Table 40: Information used within the MAC\_PAGE.Ind primitive

Parameter	Information within the parameter	Normative action/comment
<<length of page field>>	20 or 36	
<<long flag>>	long	is only relevant if length of page field = 36
<<SDU>>		

Table 41: Information used within the DL-BROADCAST-ind primitive

Parameter	Information within the parameter	Normative action/comment
<<Message unit length>>	3, 5 octets	
<< Message unit>>	The data from the <<SDU>> from the MAC_PAGE.Ind primitive	

## 11.6.2 Expedited broadcast

The procedure shall be performed as defined in EN 300 175-4 [4], subclauses 6.2.1, 8.3.3.1, 9.4.2.1 and 9.4.2.2 and EN 300 175-3 [3], subclause 8.2.1. The following text together with the associated subclauses define the mandatory requirements with regard to the present document.

The primitive exchange and their contents is similar to the Normal Broadcast except that the DL\_EXPEDITED primitives are used instead of the DL\_BROADCAST and the type of broadcast is identified as "fast". Short frame format (frame length = 3) and long frame format (frame length = 5) are required to be supported.

**Table 42: Information used within the DL-EXPEDITED-req primitive**

Parameter	Information within the parameter	Normative action/comment
<<Cluster address list>>	all cluster/an integer	
<<Message unit length>>	3, 5 octets	Short and long frame format are required to be supported
<<Message unit>>	From the NWK layer	

**Table 43: Information used within the MAC\_PAGE.Reg primitive**

Parameter	Information within the parameter	Normative action/comment
<<cluster ID>>	all clusters/an integer	
<<page type>>	fast	
<<length of page field>>	20 or 36	
<<long flag>>	long	is only relevant if length of page field = 36
<<SDU>>	The data from the <<Message unit>> received in the DL-EXPEDITED-req primitive	

**Table 44: Information used within the MAC\_PAGE.Ind primitive**

Parameter	Information within the parameter	Normative action/comment
<<length of page field>>	20 or 36	
<<long flag>>	long	is only relevant if length of page field = 36
<<SDU>>		

**Table 45: Information used within the DL-EXPEDITED-ind primitive**

Parameter	Information within the parameter	Normative action/comment
<<Message unit length>>	3, 5 octets	
<< Message unit>>	The data from the <<SDU>> from the MAC_PAGE.Ind primitive	

## 11.7 Connection handover

### 11.7.1 Class A connection handover

For single bearer connections the procedure shall be performed according to EN 300 444 [8] subclause 9.7.

For multi-bearer connections the procedure shall be performed as defined in EN 300 175-4 [4] subclauses 9.2.7.3, 9.2.7.3.1, 9.2.7.3.3, 10.5 and 9.2.7.1.2. The following subclauses define the mandatory requirements with regard to the present document.

If FP receives a connection handover request and this is executed successfully, then the FP shall release the old MAC Logical Connection (MBC) if this is still in suspend state.

### 11.7.1.1 Voluntary handover

As a result of continued poor quality of service from the MAC layer, the LLME in the PT shall inform the PT LAPC entity, the LAPC entity shall enter the Handover pending condition, timer <DL.05> is not needed to be started, a new MAC connection shall be requested to be established.

The establishment of a new MAC connection shall be achieved by the LLME connection setup procedure according to subclause 10.5, immediately followed by a connection modification procedure (see EN 300 175-4 [4] subclause 10.2.3 case B) in case of multibearer connections to restore the attributes of the old connection.

If a new MAC connection is successfully established the LAPC entity shall leave the Handover pending condition, and one of the two MAC connections shall be released by the PT using the LLME MAC connection release procedure (see EN 300 175-4 [4] subclause 9.3.1.2).

This implies that in case of unsuccessful handover the associated links shall not be released since the connection is still operational (even with bad quality).

NOTE 1: Any time an unexpected upward MAC\_DIS-ind primitive is received, the receiver of this primitive may assume that the connection and the far side of the link have been released.

NOTE 2: For multibearer connections the handover may be done by downgrading the bandwidth either to 1 or to 0 bearers.

### 11.7.1.2 Associated procedure

#### 11.7.1.2.1 LLME connection handover management

The procedure shall be performed as defined in EN 300 175-4 [4] subclause 10.5. The following text together with the associated subclauses define the mandatory requirements with regard to the present document.

Timer <DL.06> shall be started either after the connection handover is successfully completed or immediately after N251 successive "unsuccessful" connection handover attempts.

It shall be stopped upon an initiation of a link release "abnormal" (see EN 300 444 [8] subclause 8.38) or release indication from MAC layer (see EN 300 444 [8] subclause 9.3).

As long as <DL.06> is running, no connection handover attempts shall be initiated.

### 11.7.1.3 Exceptional case

#### 11.7.1.3.1 Receipt of a request for link release

If while in the connection handover pending condition a link release request has been received from the own NWK layer the handover pending condition shall be cleared and class A link release procedure (see EN 300 444 [8] subclause 9.3) shall be performed.

The associated connection and the connection for which establishment is in progress shall also be released using the LLME release of the MAC connection procedures (see EN 300 175-4 [4] subclause 9.3.1.2).

## 11.8 Connection modification

The procedure shall be performed as defined in EN 300 175-4 [4], subclause 10.2.3. The following text together with the associated subclauses define the mandatory requirements with regard to the present document.

During the establishment of advanced connections, whenever the MAC\_CON-req primitive has specified a multi-bearer connection or the connection type as "unknown" a MAC\_MOD-req primitive shall be sent to identify the exact connection attributes. The primitive shall not be sent immediately after the MAC\_CON-req primitive instead it shall be delayed in order to allow some higher layer exchanges to occur using a C<sub>S</sub> only MAC service. These higher layer exchanges shall be used to agree the wanted service, which shall then be invoked at the MAC layer using the MAC\_MOD primitives.

Connection modification may be used to modify service attributes of established advanced connections of known service type. This may be used by the LLME to optimize the use of the resources by changing the bandwidth of existing connections (including the complete reversal of unidirectional connections) in response to service demands or it may be used in response to a NWK layer request for changing the connection characteristics (i.e. slot type, service type).  $C_F$  service data integrity shall always be preserved during connection modification. If the "minimum bearers" parameter is changed to a value greater than the actual bandwidth, the physical connection will be released if the MAC cannot achieve the new requirement.

Connection modification may occur during connection handover as well.

**Table 46: Values used within the MAC\_MOD-req primitive**

Parameter	Information within the parameter	Normative action/comment
<<MCEI>>	MAC Connection Endpoint Identifier	Refer to EN 300 175-4 [4], subclause 10.2.4.4
<<ECN>>	All	Refer to EN 300 175-4 [4], subclause 10.2.4.4
<<Slot type>>	Full slot	
<<switching>>	Non	
<<Service type>>	Ip_error_detection	
	Ip_error_correction	Optional
Target number of uplink simplex bearers	All	In the range agreed by the higher layers
Target number of downlink simplex bearers	All	In the range agreed by the higher layers
Minimum acceptable uplink simplex bearers	All	In the range agreed by the higher layers
Minimum acceptable downlink simplex bearers	All	In the range agreed by the higher layers

**Table 47: Values used within the MAC\_MOD-ind primitive**

Parameter	Information within the parameter	Normative action/comment
<<MCEI>>	MAC Connection Endpoint Identifier	Refer to EN 300 175-4 [4], subclause 10.2.4.4
<<ECN>>	All	Refer to EN 300 175-4 [4], subclause 10.2.4.4
<<Slot type>>	Full slot	
<<switching>>	Non	
<<Service type>>	Ip_error_detection	
	Ip_error_correction	Optional
<<Max lifetime>>	All	As agreed by the higher layers
Result	accept/reject	

**Table 48: Values used within the MAC\_MOD-cfm primitive**

Parameter	Information within the parameter	Normative action/comment
<<MCEI>>	MAC Connection Endpoint Identifier	Refer to EN 300 175-4 [4], subclause 10.2.4.4
<<ECN>>		Refer to EN 300 175-4 [4], subclause 10.2.4.4
Result	Accept/reject	

## 11.9 Encryption switching

The procedure shall be performed as defined in EN 300 175-4 [4], subclause 10.6, EN 300 175-7 [7], subclauses 6.5.3 and 6.4.6 and EN 300 175-3 [3], subclause 6.2.3. The following text together with the associated subclauses define the mandatory requirements with regard to the present document.

The procedure for encryption deactivation is not required to be supported since a new connection is always established in clear mode. Therefore any connection or link release implies encryption deactivation.

The encryption deactivation is mandatory only if service DPRS-D.11 (encryption activation) is supported.

### 11.9.1 Associated procedure

#### 11.9.1.1 Providing Encryption key to the MAC layer

On receipt of the DCK in a DL-ENC\_KEY-req primitive the DLC shall transmit it to the MAC layer.

A record shall be kept for the active (the one used for the current encryption) DCK for use in case of connection handover.

### 11.9.2 Exceptional cases

#### 11.9.2.1 Encryption fails

An encryption attempt which fails means the desired "Crypted" mode is not achieved. If the MAC fails to switch from clear to encrypted mode the connection is released and the DLC layer is informed by a MAC\_DIS.Ind primitive. At the peer side this indication shall arrive as a result of the connection release.

#### 11.9.2.2 Connection handover of ciphered connections

During a connection handover the new connection shall always be established in clear (encryption disabled). If the status of the old connection was "Crypted" then the LLME at the PT side shall command the DLC layer to enable ciphering on the new connection as soon as it is established by issuing a MAC\_ENC\_KEY-req primitive to the MAC layer (to provide the cipher key) followed by a MAC\_ENC\_EKS-req primitive with the flag set to "Go Crypted".

NOTE: If during the time that data has been encrypted a new DCK has been produced and stored when a connection handover of ciphered connection is performed the new key is not available at the DLC layer. Therefore the ciphering is performed using the old DCK.

Notification of successful encryption of the new connection shall be indicated by receipt of a MAC\_ENC\_EKS-cfm at the initiating side and a MAC\_ENC\_EKS-ind at the peer side. In this event no indication shall be issued to the NWK layer.

If the encryption of the new connection fails, the connection is released and the DLC layer is informed using the MAC\_DIS-ind primitive. No indication with a MAC\_ENC\_EKS-ind or a MAC\_ENC\_EKS-cfm primitive shall be provided.

## 12 NWK layer procedures

The following clauses define the process mandatory procedures which are in the scope of the DPRS. Some of these procedures introduce modifications to procedures described in GAP-EN 300 444 [8], or, CAP-EN 300 824 [9].

All protocol elements listed in the following clauses are process mandatory i.e. the FT and PT depending on their role in the procedure shall send or shall receive and process the relevant protocol elements as listed in the respective tables if not explicitly stated as being optional.

The primitives used in procedure descriptions are defined only for the purpose of describing layer-to-layer interactions. The primitives are defined as an abstract list of parameters, and their concrete realization may vary between implementations. No formal testing of primitives is intended. The primitive definitions have no normative significance.

This profile does not prevent any PT or FT from transmitting or receiving and processing any other NWK layer message or information element not specified in the profile. A PT or FT receiving an unsupported NWK layer message or information element which it does not recognize shall ignore it, as specified in EN 300 175-5 [5], clause 17. Deviations from this rule, if any, will be explicitly stated.

### 12.1 Outgoing call request

The procedure shall be performed as defined in EN 300 444 [8], subclauses 8.2 with the following modification.

**Table 49: Values used within the {CC-SET-UP} message**

Information element	Field within the information element	Standard values within the field/information element	Normative action/comment
<<Basic service>>			
	<Basic service>	1111	For the additional information elements needed to identify the required service/parameters see DPRS-N.2 Service Negotiation feature.

### 12.2 Incoming call request

The procedure shall be performed as defined in EN 300 444 [8], subclauses 8.12. The following text together with the associated subclauses define the mandatory requirements with regard to the present document.

**Table 50: Values used within the {CC-SET-UP} message**

Information element	Field within the information element	Standard values within the field/information element	Normative action/comment
<<Basic service>>			
	<Basic service>	1111	For the additional information elements needed to identify the required service/parameters see DPRS-N.2 Service Negotiation feature.



## 12.3 Terminal capability indication

The procedure shall be performed as defined in EN 300 444 [8], subclauses 8.17. The following text together with the associated subclauses define the mandatory requirements with regard to the present document.

In addition the following fields need to be supported in regard to the particular DPRS application supported, see annexes B and C.

**Table 51: Values used within the <<TERMINAL CAPABILITY>> information element**

Information element	Field within the information element	Standard values within the field/information element	Normative action/comment
<<Terminal capability>>			
	<Profile indicator_1>	"x1xxxx"B	DPRS FREL support (see note)
	<Profile indicator_1>	"1xxxxx"B	Asymmetric bearer
	<Profile indicator_2>	"xxxxx1"B	DPRS Stream support (see note)
NOTE: At least one of these bit maps shall contain 1.			

## 12.4 Internal call keypad

The procedure shall be performed as defined in EN 300 444 [8], subclauses 8.19. The following text together with the associated subclauses define the mandatory requirements with regard to the present document.

This type of internal calls cannot negotiate service parameters at establishment phase, the negotiated for the existing call service parameters can only be used. If new call service parameters are required the procedures related to feature "In call service change" shall be used.

## 12.5 Call Resources/Parameters negotiation

The procedure relates to feature Service Negotiation [DPRS-N.34] and shall be performed as defined in EN 300 175-5 [5], subclauses 9.3.1.3 and 9.3.2.3, 15.2.4, and, 15.2.5. The following text together with the associated subclauses defines the mandatory requirements with regard to the present document. The procedure introduces modification to the Outgoing call request and Incoming call request procedures as defined in EN 300 444 [8] subclauses 8.2 and 8.12 respectively, and, to the External Handover Setup as defined in EN 300 824 [9]. The procedure introduces as well modification to the Overlap Sending, Outgoing Call connection and Incoming call confirmation procedures as defined in EN 300 444 [8] subclauses 8.3, 8.6 and 8.13 respectively. All modifications constitutes information elements that need to be provided in addition to the already specified elements in other subclauses.

To indicate/negotiate the exact parameters of the requested service the initiating side shall include into the {CC-SETUP} message:

- a <<IWU ATTRIBUTES>> information element used to indicate the type/characteristics of the service requested;
- a <<CALL ATTRIBUTES>> information element;
- a <<CONNECTION ATTRIBUTES>> information element;
- a <<TRANSIT DELAY>> information element;
- a <<WINDOW SIZE>> information element.

Table 52: Values used within the {CC-SETUP} message

Information element	Field within the information element	Standard values within the field/information element	Normative action/comment
<<IWU attributes>>			
	<Coding standard>	01	Profile defined coding
	<Profile>	00000 00001	FREL support Stream support
	<Negotiation Indicator>	000, 010	- Negotiation not possible (see note 1) - Peer attribute negotiation
	<Profile Subtype>	All	The required for support value and the complete structure of the IWU attributes relevant to this standard are defined in the relevant Interworking annexes of the present document.
<<Call attributes>>			DPRS requires for support only one set of Call attributes. If this information element is not included, default values shall be assumed, see subclause 12.5.1.
	<Coding standard>	00	
	<NWK layer attributes>	00010	DPRS
	<C-plane class>	010	Class A shared is only mandatory, rest are optional and need not be supported by the peer side.
	<C-plane routing>	0000, 0001, 0010	C <sub>S</sub> only; C <sub>S</sub> preferred/C <sub>F</sub> accepted; C <sub>F</sub> preferred/C <sub>S</sub> accepted; Support of C <sub>F</sub> is optional.
	<ext5>	1	
	<U-plane symmetry>	00	Symmetric
	<LU identification>	01010	LU10
	<ext6>	1	
	< U-plane class>	101	Class 2; SElective
	< U-plane frame type>	1010	FU10a/c mandatory for support
		1011	FU10b optional, allowed only in symmetric connections - can only be used if both sides indicate the support of FU10b, FU10a shall be used otherwise.
<<Connection attributes>>			Signifies the maximum capabilities of the sender for the requested call. If not included the default value shall be assumed, see subclause 12.5.1.
	<Symmetry>	001, 100, 110	Symmetric Asymmetric FT to PT with at least 1 duplex bearer Asymmetric PT to FT with at least 1 duplex bearer
	<Connection identity>	0000	Not yet numbered
	ext4	0, 1	1 - If "symmetric" has been indicated; in such case Octet 4a and following shall not be included
	<Target bearers (P => F direction)>	00nnnnn nnnnn = 1 to 23	If "Symmetric" has been indicated max. value that need to be supported is 12
	ext4a	0	
	<Minimum bearers (P => F direction)>	01nnnnn nnnnn = 0 to 23	Shall be omitted if "Symmetric" has been indicated
	ext4b	0	
	<Target bearers (F => P direction)>	00nnnnn nnnnn = 1 to 23	Shall be omitted if "Symmetric" has been indicated
	ext4c	1	
	<Minimum bearers (F => P direction)>	01nnnnn nnnnn = 0 to 23	Shall be omitted if "Symmetric" has been indicated
	<ext5>	0, 1	1 - If "symmetric" Octet 5a not included
	<MAC slot size>	100	Full slot

Information element	Field within the information element	Standard values within the field/information element	Normative action/comment
	<MAC service P=>F >	0010, 0011	IP; detect only IP; Mod-2 correct Support of "IP; Mod-2 correct" is optional
	<ext5a>	1	
	<spare>	1000	
	<MAC service F=>P>	0010, 0011	IP; detect only IP; Mod-2 correct Support of "IP; Mod-2 correct" is optional
	<Ext6>	1, 0	1 - If "symmetric" Octet 6a not included
	<C <sub>F</sub> -channel attributes P=>F >	000, 010	C <sub>F</sub> never (C <sub>S</sub> only) C <sub>F</sub> Demand/1 bearer (interrupting) Support of C <sub>F</sub> is optional.
	<MAC packet life time P=>F >	0 to 7	Values > 0 only for I <sub>P</sub> -error-correct
	<Ext6a>	1	
	<C <sub>F</sub> -channel attributes F = > P >	000, 010(check all other tables, if this value is corrected)	C <sub>F</sub> never (C <sub>S</sub> only) C <sub>F</sub> Demand/1 bearer (interrupting) Support of C <sub>F</sub> is optional.
	<MAC packet life time F =>P >	0 to 7	Values > 0 only for I <sub>P</sub> -error-correct
<<Transit delay>>			For the default value in case it is not included see subclause 12.5.1.
	< Forward Delay>	0 All	Infinite - Mandatory for support Rest - optional
	< Backward Delay>	0 All	It is not required to support different values in Backwards direction
<<Window size>>			(see note 2) For the default values if not included see subclause 12.5.1.
	ext3	0	
	<Window size value (forward)>	All	The value shall be placed in both 3 and 3a octets as defined in EN 300 175-5 [5], subclause 7.7.43, see clause D.3. Maximum allowed for this profile value = 256. (see note 3)
	ext3a	1	
	<Window size value (forward) continue>	All	
	ext4	0	
	<Window size value (backward)>	All	The value shall be placed in both 3 and 3a octets as defined in EN 300 175-5 [5], subclause 7.7.43, see clause D.3. Maximum allowed for this profile value = 256.
	ext4a	1	
	<Window size value (backward) continue>	All	
NOTE 1: This value may only be used if all other parameters have values equal to the default values, see subclause 12.5.1.			
NOTE 2: If octet 4 (i.e. 4, 4a, 4b) is omitted the values defined in Octet 3x apply for both directions.			
NOTE 3: The values introduced in 11.1.1 need to be respected in all window-size fields.			

If the parameters as indicated in the {CC-SETUP} message are not acceptable and support of negotiation is indicated in the <<IWU-ATTRIBUTES>> the receiving side shall attempt negotiation if different services are possible, otherwise the call shall be rejected using the Abnormal call release procedure as defined in EN 300 444 [8], subclause 8.7.

For negotiation of <<IWU-ATTRIBUTES>> and <<CONNECTION ATTRIBUTES>> the Peer attribute negotiation procedure as defined in EN 300 175-5 [5], subclause 15.2.5, shall be used. For negotiation of the <<TRANSIT DELAY>> and the <<WINDOW SIZE>> the Operating parameter negotiation procedure as defined in EN 300 175-5 [5], subclause 15.2.4 shall be used. The following text together with the associated subclauses define the mandatory requirements with regard to the present document.

If some of the proposed services in the {CC-SETUP} message are not acceptable the peer entity shall continue the call set-up procedure by including one alternative service description returning the appropriate <<CONNECTION ATTRIBUTES>> and/or <<CALL ATTRIBUTES>> and/or <<IWU-ATTRIBUTES>> and/or <<WINDOW SIZE>> and/or <<TRANSIT DELAY>> elements in the first response message (i.e. {CC-SETUP-ACK} or {CC-CONNECT} for FT, {CC-ALERTING} for PT).

If one or more of the values are acceptable the receiving side shall return unmodified parameters as formal acceptance of these unmodified values.

In all cases, the peer side shall only return a value less than or equal to the initial offer, and the initiating side should normally accept any reduced value, even if this value differs to the default values indicated in subclause 12.5.1. In exceptional circumstances, where the reduced value gives an unacceptable grade of service, the initiating side may release the call.

In the case of the < C-plane routing > of the <<CALL ATTRIBUTES>> the peer side may return any supported value from the values indicated in table 53. The actual C class used shall be based on the requirement for mandatory support of the C<sub>S</sub> and optionally of the C<sub>F</sub>.

The values of <Coding standard> and <Profile> in the <<IWU-ATTRIBUTES>> cannot and shall not be changed; if these values are unacceptable the receiving side shall reject the call.

The initiating entity shall indicate its acceptance of these new attributes by proceeding with the normal call set-up procedures. If it cannot support the new attributes the call shall be released using the normal release procedures. The release procedure should be used for attempt for re-negotiation of new set of attributes and, the release reason "Partial release" should be included to request maintain of the link for the new call set-up attempt. In case the exchanged parameters during the release are still not acceptable for the initiating side, the initiating side should notify the user for the failure of the call and should not immediately initiate a new attempt. If the parameters are acceptable, a new call shall be initiated. To avoid a deadlock the parameters agreed during the release shall be used and accepted.

Table 53: Values used within the response message

Information element	Field within the information element	Standard values within the field/information element	Normative action/comment
<<IWU attributes>>			
	<Coding standard>	The same as in the request	
	<Profile>	The same as in the request	
	<Negotiation Indicator>	000, 010	- Negotiation not possible (see note 1) - Peer attribute negotiation
	<Profile Subtype>	All	The required for support value and the complete structure of the IWU attributes in regard to the present document are defined in the relevant Interworking annexes of the present document.
<<Call attributes>>			
	<Coding standard>	00	
	<NWK layer attributes>	00010	DPRS
	<C-plane class>	010	
	<C-plane routing>	0000, 0001, 0010	C <sub>S</sub> only; C <sub>S</sub> preferred/C <sub>F</sub> accepted; C <sub>F</sub> preferred/C <sub>S</sub> accepted; Support of C <sub>F</sub> is optional.
	<ext5>	1	
	<U-plane symmetry>	00	Symmetric
	<LU identification>	01010	LU10
	<ext6>	1	
	< U-plane class>	101	Class 2; SElective
	< U-plane frame type>	1010	FU10a/c mandatory for support
		1011	FU10b optional, allowed only in symmetric connections - can only be used if both sides indicate the support of FU10b, FU10a shall be used otherwise.
<<Connection attributes>>			Signifies the maximum capabilities of the sender for the requested call
	<Symmetry>	001, 100, 110	Symmetric Asymmetric FT to PT with at least 1 duplex bearer Asymmetric PT to FT with at least 1 duplex bearer
	<Connection identity>	0000	Not yet numbered
	ext4	0, 1	1 - If symmetric" has been indicated; in such case Octet 4a and following shall not be included
	<Target bearers (P => F direction)>	00nnnnn nnnnn = 1 to 23	If "Symmetric" has been indicated max. value that need to be supported is 12
	ext4a	0	
	<Minimum bearers (P => F direction)>	00nnnnn nnnnn = 0 to 23	Shall be omitted if "Symmetric" has been indicated
	ext4b	0	
	<Target bearers (F => P direction)>	00nnnnn nnnnn = 1 to 23	Shall be omitted if "Symmetric" has been indicated
	ext4c	1	
	<Minimum bearers (F => P direction)>	00nnnnn nnnnn = 0 to 23	Shall be omitted if "Symmetric" has been indicated
	<ext5>	0, 1	1 - If "symmetric" Octet 5a not included
	<MAC slot size>	100	Full slot
	<MAC service P=>F >	0010, 0011	IP; detect only IP; Mod-2 correct Support of "IP; Mod-2 correct" is optional
	<ext5a>	1	

Information element	Field within the information element	Standard values within the field/information element	Normative action/comment
	<spare>	1000	
	<MAC service F=>P>	0010, 0011	IP; detect only IP; Mod-2 correct Support of "IP; Mod-2 correct" is optional
	<Ext6>	1, 0	1 - If "symmetric" Octet 6a not included
	<C <sub>F</sub> -channel attributes P=>F >	000, 010	C <sub>F</sub> never (C <sub>S</sub> only) C <sub>F</sub> Demand/1 bearer (interrupting) Support of C <sub>F</sub> is optional.
	<MAC packet life time P=>F >	0 to 7	Values > 0 only for I <sub>P</sub> -error-correct
	<Ext6a>	1	
	<C <sub>F</sub> -channel attributes F=>P >	000, 010	C <sub>F</sub> never (C <sub>S</sub> only) C <sub>F</sub> Demand/1 bearer (interrupting) Support of C <sub>F</sub> is optional.
	<MAC packet life time F=>P >	0 to 7	Values > 0 only for I <sub>P</sub> -error-correct
<<Transit delay>>			(see note 2) For the default value in case it is not included see below.
	< Forward Delay>	0 All	Infinite - Mandatory for support Rest - optional
	< Backward Delay>	0 All	It is not required to support different values in Backwards direction
<<Window size>>			(see note 2) For the default values if not included see below.
	ext3	0	
	<Window size value (forward)>	All	The value shall be placed in both 3 and 3a octets as defined in EN 300 175-5 [5], subclause 7.7.43, see clause D.3. Maximum allowed for this profile value = 256.
	ext3a	1	
	<Window size value (forward) continue>	All	
	ext4	0	
	<Window size value (backward)>	All	The value shall be placed in both 3 and 3a octets as defined in EN 300 175-5 [5], subclause 7.7.43, see clause D.3. Maximum allowed for this profile value = 256.
	ext4a	1	
	<Window size value (backward) continue>	All	
NOTE 1: This value may only be used if all other parameters have values equal to the default values, see subclause 12.5.1.			
NOTE 2: If octet 4 (i.e. 4, 4a, 4b) is omitted the values defined in Octet 3x apply for both directions.			

The negotiation of the lower resources is performed at higher layers where exchange of NWK layer messages is involved. The resources assignment is done at the lower layers. To provide proper functioning the LLME shall ensure that all responsible for the implementation of the agreed parameters layers and processes are informed in time for the result from the NWK layer procedures and specially before a resources allocation/modification is to be made at the lower layers.

The bandwidth negotiation at MAC may fail due to one of the sides being yet not informed for the negotiated values. This shall not lead to release of the call, the procedure shall be repeated.

An example for information exchange sequence is given in figure below.

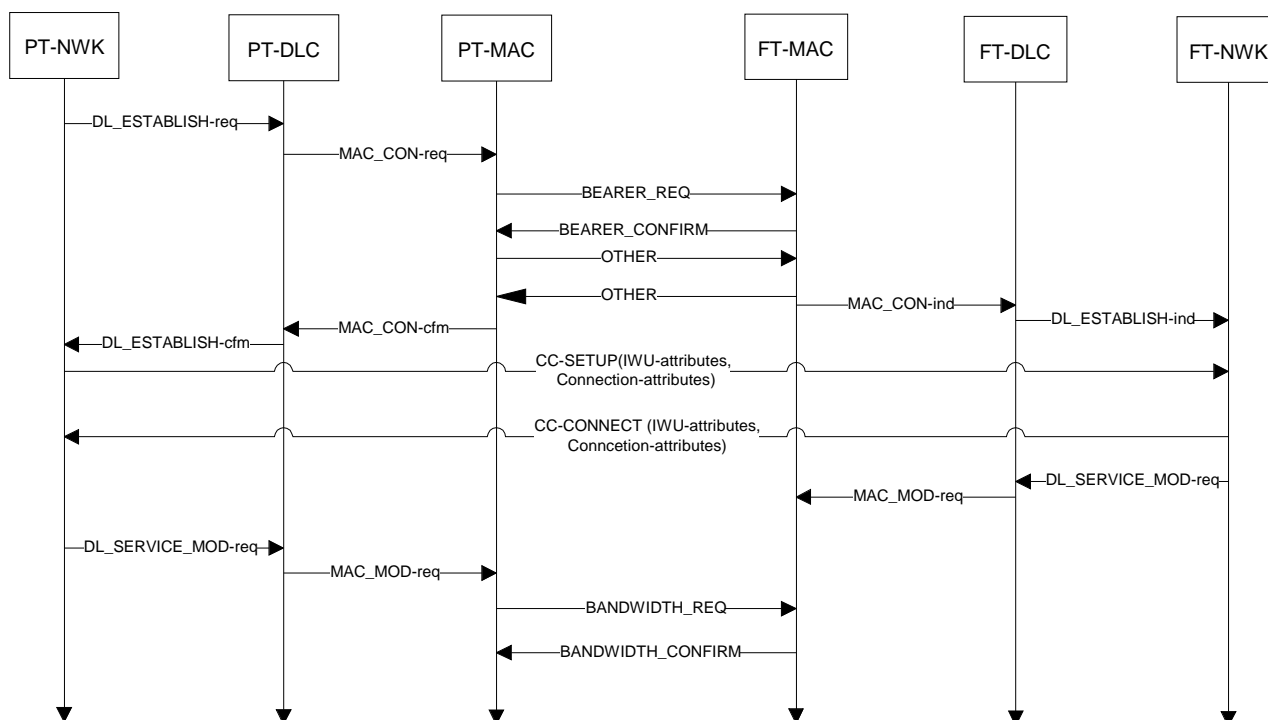

**Figure 12: Service/parameters negotiation interlayer exchange**

NOTE: The transmission of CC-SETUP and CC-CONNECT throughout the layers is not shown. Full contents of messages and primitives is not shown. Primitives are informative.

### 12.5.1 Default values

When an information element as listed below is not included the specified in this subclause default values shall be assumed. In any case, in order to avoid misunderstanding the responding side shall always include the relevant information elements, even if the default values are supported.

**Table 54: Default values for <<Call attributes>> in the "request" message**

Information element	Field within the information element	Standard values within the field/information element	Normative action/comment
<<Call attributes>>			
	<Coding standard>	00	
	<NWK layer attributes>	00010	DPRS
	<C-plane class>	010	
	<C-plane routing>	0000	C <sub>S</sub> only
	<ext5>	1	
	<U-plane symmetry>	00	Symmetric
	<LU identification>	01010	LU10
	<ext6>	1	
	< U-plane class>	101	Class 2; SElective
	< U-plane frame type>	1010	FU10a

Table 55: Default values for &lt;&lt;Connection attributes&gt;&gt; in the "request" message

Information element	Field within the information element	Standard values within the field/information element	Normative action/comment
<<Connection attributes>>			Signifies the maximum capabilities of the sender for the requested call. If not included the default value shall be assumed, see below.
	<Symmetry>	001	Symmetric
	<Connection identity>	0000	Not yet numbered
	ext4	1	
	<Target bearers both direction>	1	
	<ext5>	1	
	<MAC slot size>	100	Full slot
	<MAC service both directions>	0010	IP; detect only
	<Ext6>	1	
	<C <sub>F</sub> -channel attributes P=>F >	000	C <sub>F</sub> never (C <sub>S</sub> only) Both directions
	<MAC packet life time P=>F >	0 (I <sub>P</sub> -error-detect) 4 (I <sub>P</sub> -error-correct)	OK

Table 56: Default values for &lt;&lt;Transit Delay&gt;&gt; in the "request" message

Information element	Field within the information element	Standard values within the field/information element	Normative action/comment
<<Transit delay>>			
	< Forward Delay>	0	Infinite
	< Backward Delay>	0	Infinite

Table 57: Default values for &lt;&lt;Window size&gt;&gt; in the "request" message

Information element	Field within the information element	Standard values within the field/information element	Normative action/comment
<<Window size>>			
	ext3	0	
	<Window size value (forward)>	0000001	The value shall be placed in both 3 and 3a octets as defined in EN 300 175-5 [5], subclause 7.7.43, see clause D.3. Default value = 32
	ext3a	1	
	<Window size value (forward) continue>	0000000	
	ext4	0	
	<Window size value (backward)>	0000001	The value shall be placed in both 3 and 3a octets as defined in EN 300 175-5 [5], subclause 7.7.43, see clause D.3. Default value = 32
	ext4a	1	
	<Window size value (backward) continue>	0000000	



## 12.6 Bandwidth Change

The procedure relates to feature In Call Service Change [DPRS N.35] and shall be performed as defined in EN 300 175-5 [5], subclauses 9.6.1 and 9.6.2. The following text together with the associated subclauses defines the mandatory requirements with regard to the present document.

Bandwidth changes shall be defined as changes that may be realized by modification of the existing MAC connection. The <<CONNECTION-ATTRIBUTES>> element shall always be included to define the new connection bandwidths.

**Table 58: Values used within the {CC-SERVICE-CHANGE} message**

Information element	Field within the information element	Standard values within the field/information element	Normative action/comment
<<Portable identity>>			
	<Type>	0	International Portable User Identity (IPUI)
	<PUT>	All	Area dependent
	<PUN>	All	Area dependent
<< Service Change Info >>			
	<Ext3>	1	
	<Coding standard>	00	DECT standard coding
	<M>	0/1	Initiating/Receiving side is master
	<Change Mode>	0010	Bandwidth change
<<Connection attributes>>			Signifies the maximum capabilities of the sender for the requested call
	<Symmetry>	001,100,110	Symmetric Asymmetric FT to PT with at least 1 duplex bearer Asymmetric PT to FT with at least 1 duplex bearer
	<Connection identity>	0000	Not yet numbered
	ext4	0, 1	1 - If "symmetric" has been indicated; in such case Octet 4a and following shall not be included
	<Target bearers (P => F direction)>	00nnnn nnnn = 1 to 23	If "Symmetric" has been indicated max. value that need to be supported is 12
	ext4a	0	
	<Minimum bearers (P => F direction)>	00nnnn nnnn = 0 to 23	Shall be omitted if "Symmetric" has been indicated
	ext4b	0	
	<Target bearers (F => P direction)>	00nnnn nnnn = 1 to 23	Shall be omitted if "Symmetric" has been indicated
	ext4c	1	
	<Minimum bearers (F => P direction)>	00nnnn nnnn = 0 to 23	Shall be omitted if "Symmetric" has been indicated
	<ext5>	0, 1	1 - If "symmetric" Octet 5a not included
	<MAC slot size>	100	Full slot
	<MAC service P=>F >	0010, 0011	IP; detect only IP; Mod-2 correct Support of "IP; Mod-2 correct" is optional
	<ext5a>	1	
	<spare>	1000	
	<MAC service F=>P>	0010, 0011	IP; detect only IP; Mod-2 correct Support of "IP; Mod-2 correct" is optional

Information element	Field within the information element	Standard values within the field/information element	Normative action/comment
	<Ext6>	1, 0	1 - If "symmetric" Octet 6a not included
	<C <sub>F</sub> -channel attributes P=>F >	000, 010	C <sub>F</sub> never (C <sub>S</sub> only) C <sub>F</sub> Demand/1 bearer (interrupting) Support of C <sub>F</sub> is optional.
	<MAC packet life time P=>F >	0 to 7	values >0 only for I <sub>P</sub> _error_correct
	<Ext6a>	1	
	<C <sub>F</sub> -channel attributes F=>P >	000, 010	C <sub>F</sub> never (C <sub>S</sub> only) C <sub>F</sub> Demand/1 bearer (interrupting) Support of C <sub>F</sub> is optional.
	<MAC packet life time F=>P >	0 to 7	values >0 only for I <sub>P</sub> _error_correct

**Table 59: Values used within the {CC-SERVICE-ACCEPT} message**

Information element	Field within the information element	Standard values within the field/information element	Normative action/comment
			All optional - The receiving side is not allowed to suggest back different to the requested settings

## 12.6.1 Associated procedures

### 12.6.1.1 Timer F/P <CC\_service> management

<CC\_service>: Service Change timer;

Value: 20 seconds

Start: {CC-SERVICE-CHANGE} message is sent;

Stop: An indication for link release from the DLC is received; A {CC-SERVICE-ACCEPT} or a {CC-SERVICE-REJECT} message is received; {CC-RELEASE}, {CC-RELEASE-COM} messages are sent or received.

## 12.6.2 Exceptional cases

### 12.6.2.1 Service change request is rejected

If the receiving side is not able to handle the requested service change it shall reject it.

**Table 60: Values used within the {CC-SERVICE-REJECT} message**

Information element	Field within the information element	Standard values within the field/information element	Normative action/comment
			All optional

### 12.6.3 Examples

The modification of the lower resources is initiated from the higher layers where exchange of NWK layer messages is involved. The resources assignment is done at the lower layers. To provide proper functioning the LLME shall ensure that all responsible layers and processes are informed in time for the result from the NWK layer procedures before a resources allocation/modification is to be made at the lower layers.

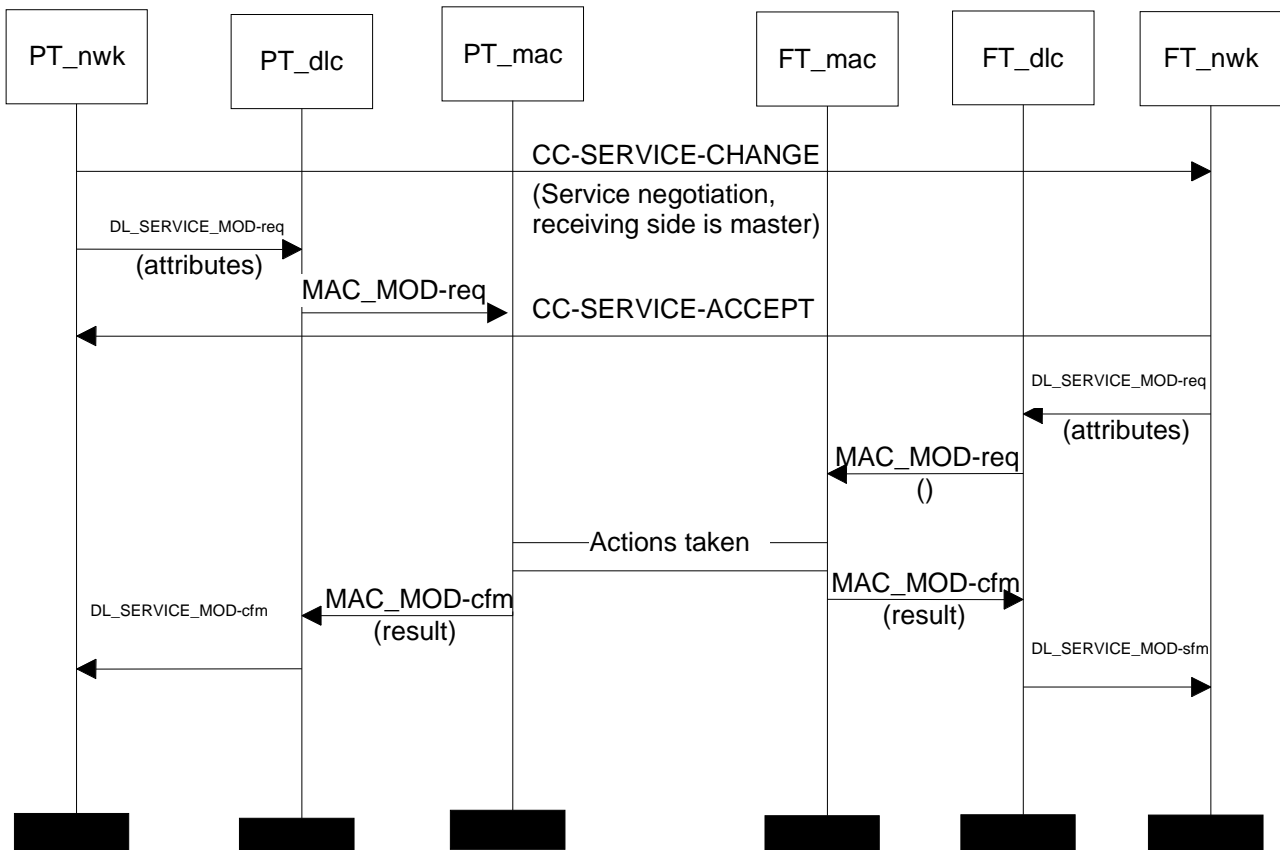

Figure 13: Example of service change with the receiving side initiating the resources allocation

## 12.7 Connection Reversal

The procedure relates to feature In Call Service Change [DPRS-N.35] and shall be performed as defined in EN 300 175-5 [5], subclauses 9.6.1 and 9.6.2. The following text together with the associated subclauses define the mandatory requirements with regard to the present document.

Connection reversal shall be defined as changes that may be realized by modification of the existing MAC connection. The <<CONNECTION-ATTRIBUTES>> element shall always be included to define the new connection bandwidths.

For the {CC-SERVICE-CHANGE}, {CC-SERVICE-ACCEPT} and {CC-SERVICE-REJECT} the requirements from subclause 12.7 apply with the following modification.

Table 61: Values used within the {CC-SERVICE-CHANGE} message

Information element	Field within the information element	Standard values within the field/information element	Normative action/comment
<< Service Change Info >>			
	<Change Mode>	0001	Connection Reversal - the complete reversal of unidirectional connections
<<Connection Attributes>>			
	<Symmetry>	100, 110	Asymmetric FT to PT with at least 1 duplex bearer Asymmetric PT to FT with at least 1 duplex bearer
	<Connection identity>	0000	Not yet numbered
	ext4	0, 1	1 - If symmetric" has been indicated; in such case Octet 4a and following shall not be included
	<Target bearers (P => F direction)>	00nnnnn nnnnn = 1 to 23	
	ext4a	0	
	<Minimum bearers (P => F direction)>	00nnnnn nnnnn = 0 to 23	If this is omitted the default value shall be as defined in "Target bearers (P => F direction)"
	ext4b	0	
	<Target bearers (F => P direction)>	00nnnnn nnnnn = 1 to 23	
	ext4c	1	
	<Minimum bearers (F => P direction)>	00nnnnn nnnnn = 0 to 23	If this is omitted the default value shall be as defined in "Target bearers (F => P direction)"
	<MAC slot size>	100	Full slot
	<ext5>	1	Octet 5a not included
	<MAC service>	0010, 0011	I <sub>P</sub> ; detect only I <sub>P</sub> ; Mod-2 correct Support of "I <sub>P</sub> ; Mod-2 correct" is optional
	<Ext6>	1	Octet 6a not included
	<C <sub>F</sub> -channel attributes>	000, 010	C <sub>F</sub> never (C <sub>S</sub> only) C <sub>F</sub> Demand/1 bearer (interrupting) Support of C <sub>F</sub> is optional
	<MAC packet life time>	All	

## 12.8 IWU-attributes change

The procedure relates to feature In Call Service Change [DPRS-N.35] and is similar to the Bandwidth change procedure as described in subclause 8.3 and in EN 300 175-5 [5], subclauses 9.6.1 and 9.6.2. The following text together with the associated subclauses define the mandatory requirements with regard to the present document.

The IWU- attributes change shall be defined as changes that may be realized by modification of the existing MAC connection. The <<IWU-ATTRIBUTES>> element shall always be included to define the new strings.

For the {CC-SERVICE-CHANGE}, {CC-SERVICE-ACCEPT} and {CC-SERVICE-REJECT} the requirements from subclause 12.7 apply with the following modification.

Table 62: Values used within the {CC-SERVICE-CHANGE} message

Information element	Field within the information element	Standard values within the field/information element	Normative action/comment
<< Service Change Info >>			
	<Ext3>	1,0	Value 0 shall be only used if "Profile/Basic service and IWU attributes change" is indicated below.
	<Change Mode>	"1100"	IWU attribute change
<<IWU attributes>>			
	<Coding standard>	01	
	<Profile>	00001	Stream support
		00000	FREL support
	<Negotiation Indicator>	000, 010	Shall be as set during the call establishment.
	<Profile Subtype>	0000	Interworking to V.24 circuits (RS232)
		1000	B-Ethernet (WLAN)

## 12.9 Dynamic Parameters Allocation

The procedure is related to feature DPRS-N.33, Dynamic parameters allocation.. The following text together with the associated subclauses define the mandatory requirements with regard to the present document.

For proper functioning of the DPRS protocol it is necessary a number of dynamic parameters to be allocated beforehand. For this purpose exchange of information included in <<SETUP-CAPABILITY>> information element is necessary. As this parameters are used in MAC or elsewhere operation for the related behaviour and requirements clauses 9, 10 or 11 may be relevant as well.

For the DPRS profile the <<SETUP-CAPABILITY>> information element as defined in EN 300 175-5 [5] subclause 7.7.40 shall apply with the following additions/modifications:

Bit:	8	7	6	5	4	3	2	1	Octet:
	0	<< SETUP-CAPABILITY >>							1
	Length of Contents (L)								2
	1	0	0	1	Setup	Page			3
	0/1	Service settings_1							4
	0/1	...							...
	1	Service settings_n							4n-1
	Parameters settings_1								5
	T903								5a
	T904								5b
	T905								5c
	T909								5d
	T910								5e
	Bearers number								5f

Figure 14: &lt;&lt;SETUP-CAPABILITY&gt;&gt; information element for DPRS

### Service settings (octet group 4):

This is a bit mapped octet group. A "1" indicates support for the specified service setting. Reserved bits shall be set to zero and need not be checked in the receiver.

**Service\_settings\_1 Coding (Octet 4):**

<b>Bits</b>	<b>7 6 5 4 3 2 1</b>	<b>Meaning</b>
x x x x x x	1	I <sub>p_error_correct</sub> supported
x x x x x	1 x	Allow suppression of bearer quality messages for asymmetric connection (EN 300 175-3 [3], 7.3.5.4) only if all Q2 bits are =1
x x x x	1 x x	Allow suppression of bearer quality messages for asymmetric connection (EN 300 175-3 [3], 7.3.5.4) in any case.
x x x	1 x x x	Q1 bit is used (I <sub>p_error_detect</sub> only).

All the rest reserved for further standardization.

**Service\_settings\_n Coding (Octet 4n-1):**

This is provided in case of demands for further DPRS standardization.

**Parameters\_settings\_1 (octet group 5):**

This is a bit mapped octet group. A "1" indicates that value for the particular parameter is provided otherwise the default value for this parameter shall be assumed. Reserved bits shall be set to zero and need not be checked in the receiver.

<b>Bits</b>	<b>8 7 6 5 4 3 2 1</b>	<b>Meaning</b>
x x x x x x	1	Timer T903 value is provided
x x x x x	1 x	Timer T904 value is provided
x x x x	1 x x	Timer T905 value is provided
x x x	1 x x x	Timer T909 value is provided
x x x	1 x x x x	Timer T910 value is provided
x x	1 x x x x x	Bearer numbers provided

All the rest reserved for further standardization.

When number of values are provided they shall be provided in the order indicated here. For example, if only T905 and T910 values are included octets 5, 5c and 5e need to be included in this order.

More Parameters may be added in future standardization by including of octet 6 and following 6a,...6n.

**Timer T903 value (octet 5a):**

The value shall be binary coded with 1 unit = 2 frames; the value "11111111" is reserved and shall not be used.

**Timer T904 value (octet 5b):**

The value shall be binary coded with 1 unit = 1 frame; the value "11111111" is reserved and shall not be used.

**Timer T905 value (octet 5c):**

The value shall be binary coded with 1 unit = 1 frame; the value "11111111" is reserved and shall not be used.

**Timer T909 value (octet 5d):**

The value shall be binary coded with 1 unit = 1 multi frame; the value "11111111" shall be understood as "infinite"; If the <Setup capability coding> value indicates "01" this value (if included) shall be set to "0".

**Timer T910 value (octet 5e):**

The value shall be binary coded with 1 unit = 4 multi frames; the value "11111111" shall be understood as "infinite"

**Bearers number value (octet 5f):**

The value shall be binary coded with LSB placed on bit 0.

It shall identify the max number of bearers that can be supported per connection.

Table 63: Values used within the &lt;&lt;SETUP-CAPABILITY&gt;&gt; information element

Information element	Field within the information element	Standard values within the field/information element	Normative action/comment
<<Set-up capability>>			
	<ext3>	0	
	<Protocol discriminator>	001	DPRS
	<Set-up>	01, 10	Setting and support depends on the relevant capability. Fast setup is optional for support.
	<Page>	01, 10	Setting and support depends on the relevant capability. Fast paging is optional for support.
	<ext4>	1	
	<Service_settings_1>	0000000	Default value - mandatory for support
		xxxxx1	lp_error_correct supported - optional for support
		xxxx1x	Allow suppression of bearer quality messages for asymmetric connection (EN 300 175-3 [3], 7.3.5.4) only if all Q2 bits are =1 optional for support
		xxxx1xx	Allow suppression of bearer quality messages for asymmetric connection (EN 300 175-3 [3], 7.3.5.4) in any case. optional for support
		xxx1xxx	Q1 bit is used (lp_error_detect only). optional for support
	<Parameter_settings_1 >	As relevant	If a bit is set to "0" the default values as indicated in A.1.3.1 and A.1.3.2 shall be assumed
	T903	For the allowed values see A.1.3.1	If indicated in <Parameter_settings_1> that value for this is included (i.e. xxxxxx1)
	T904	For the allowed values see A.1.3.1	If indicated in <Parameter_settings_1> that value for this is included (i.e. xxxxx1x)
	T905	For the allowed values see A.1.3.1	If indicated in <Parameter_settings_1> that value for this is included (i.e. xxxxx1xx)
	T909	For the allowed values see A.1.3.2	If indicated in <Parameter_settings_1> that value for this is included (i.e. xxx1xxx)
	T910	For the allowed values see A.1.3.1	If indicated in <Parameter_settings_1> that value for this is included (i.e. xxx1xxxx)
	Bearer number	1 to 24	

A PT shall include the <<SETUP-CAPABILITY>> information element in the {ACCESS-RIGHTS-REQUEST} and {LOCATE-REQUEST} messages.

A FT shall include the <<Set-up capability>> information element in the {ACCESS-RIGHTS-ACCEPT} and {LOCATE-ACCEPT} messages. In addition the FT may include the <<SETUP-CAPABILITY>> in a {MM-INFO-SUGGEST} message or in a {CLMS-FIXED} message.

Both sides are required to understand and react properly upon receipt of a <<SETUP-CAPABILITY>> information element as described in this subclause.

In regard to the service support indicated in the <service settings> both sides are allowed to use a particular setting only if both sides have indicated support of this service.

In regard to the values indicated in the <Parameters settings> see subclauses A.1.3.1 and A.1.3.2. For the T910 parameter the lower indicated value by either side shall be considered as the agreed value and used afterwards even if this is lower than the default value as indicated in subclause A.1.3.2. In all cases if a side does not provide setting for a particular parameter the default values as indicated in subclauses A.1.3.1 and A.1.3.2 shall be assumed as being indicated".

For the complete contents of {ACCESS-RIGHTS-REQUEST} and {ACCESS-RIGHTS-ACCEPT} the requirements of EN 300 444 [8], subclause 8.30 shall apply.

For the complete contents of {LOCATE-REQUEST} and {LOCATE-ACCEPT} the requirements of EN 300 444 [8], subclause 8.28 shall apply.

For the transmission of the {MM-INFO-SUGGEST} message the Procedure for parameter retrieval initiated by the FT as specified in EN 300 175-5 [5], subclause 13.7 shall apply.

For the contents of {MM-INFO-SUGGEST} the following requirements apply:



Table 64: Values used within the {MM-INFO-SUGGEST} message

Information element	Field within the information element	Standard values within the field/information element	Normative action/comment
<<Info type>>			
	<Parameter type>	0000110	Dynamic parameters allocation
<<Set-up capability>>			
	<ext3>	0	
	<Protocol discriminator>	001	DPRS
	<Set-up>	01, 10	Setting and support depends on the relevant capability. Fast setup is optional for support.
	<Page>	01, 10	Setting and support depends on the relevant capability. Fast paging is optional for support.
	<ext4>	1	Octet 4 shall always be included even if the default values are only supported
	<Service_settings_1>	0000000	Default value - mandatory for support
		xxxx1x (Sort the codings)	Allow suppression of bearer quality messages for asymmetric connection (EN 300 175-3 [3], 7.3.5.4) only if all Q2 bits are =1 optional for support
		xxx1xxx	Q1 bit is used (I <sub>p</sub> _error_detect only). optional for support
		xxxxx1	I <sub>p</sub> _error_correct supported - optional for support
		xxxx1xx1x	Allow suppression of bearer quality messages for asymmetric connection (EN 300 175-3 [3], 7.3.5.4) in any case. Allow suppression of bearer quality messages for asymmetric connection (EN 300 175-3 [3], 7.3.5.4) - optional for support optional for support
		xx1xxxx	C <sub>F</sub> Supported
	<Parameter_settings_1 >	As relevant	Octet 5 shall always be included, if the default values are only supported it shall be set to "0000000", and if this is the value received the receiving side shall proceed as the default values as indicated in A.1.3.1 and A.1.3.2 were indicated
	T903	For the allowed values see A.1.3.1	If indicated in <Parameter_settings_1> that value for this is included (i.e. xxxxxx1)
	T904	For the allowed values see A.1.3.1	If indicated in <Parameter_settings_1> that value for this is included (i.e. xxxxx1x)
	T905	For the allowed values see A.1.3.1	If indicated in <Parameter_settings_1> that value for this is included (i.e. xxxxx1xx)
	T909	For the allowed values see A.1.3.2	If indicated in <Parameter_settings_1> that value for this is included (i.e. xxx1xxx)
	T910	For the allowed values see A.1.3.1	If indicated in <Parameter_settings_1> that value for this is included (i.e. xxx1xxxx)

For the transmission of the {CLMS-FIXED} message the Procedure for parameter retrieval initiated by the FT as specified in EN 300 175-5 [5], subclause 12.3.1 shall apply with the following clarifications.

For the contents of {CLMS-FIXED} EN 300 175-5 [5], subclause 8.3 shall apply with the following modification/clarifications:

**Table 65: Values used within the {CLMS-FIXED} message address section**

Information element	Field within the information element	Standard values within the field/information element	Normative action/comment
<A>		1	address section
<CLMS header>		100	Bit stream - multi-section
<Address>			2 octets of CLMS TPUI
Protocol Discriminator		00000001	DECT Information Element coding
Length Indicator		Any	

**Table 66: Values used within the {CLMS-FIXED} message data section**

Information element	Field within the information element	Standard values within the field/information element	Normative action/comment
<A>		0	data section
<CLMS header>		n n n	Data section number
<Data/Fill>			A complete <<Set-up capability>> information elements shall be included - more than 1 CLMS fixed data sections may be needed.
< Data/Fill (cont)>			-
< Data/Fill (cont)>			-
< Data/Fill (cont)>			-

## 12.10 Cipher-switching initiated by PT

The procedure shall be performed as defined in EN 300 444 [8], subclauses 8.34. The following text together with the associated subclauses define the mandatory requirements with regard to the present document.

As this procedure is likely to be used during call establishment in order to avoid delay in the call initiation a FT that do not support ciphering shall not ignore the {CIPHER-SUGGEST} message and shall respond with a {CIPHER-REJECT} message.

**Table 67: Standard values used within the {CIPHER-REJECT} message**

Information element	Field within the information element	Standard values within the field/information element	Normative action/comment
<<Reject reason>>			
	< Reject reason code>	17	No cipher algorithm

## 12.11 Temporary Identity Assign

The procedure shall be performed as defined in EN 300 175-5 [5], subclause 13.2.2. The following text together with the associated subclauses define the mandatory requirements with regard to the present document.

This procedure shall not be used for assignment of an individual assigned TPUI - the location registration procedure as described in EN 300 444 [8] shall be used instead. Whenever other TPUIs need to be assigned this procedure shall be used.

Table 68: Values used within the {TEMPORARY-IDENTITY-ASSIGN} message

Information element	Field within the information element	Standard values within the field/information element	Normative action/comment
<<Portable-identity>>			
	<Type>	0100000	TPUI
	<Length of id value>	20	
	<Identity-value>	Values in EN 300 175-6 [6] subclause 6.3.1 are allowed	Individual TPUIs are not allowed to be assigned with this procedure.
<<Duration>>			Inclusion of this information element is optional and PT is not required to understand it.
	<Lock limits>	111 (binary)	No limits
		101 (binary)	Temporary user limit 2
		110 (binary)	Temporary user limit 1
	<Time limits>	1	Defined time limit 1
		2	Defined time limit 2
		15	Infinite
	<Time duration>	All	

Table 69: Values used within the {TEMPORARY-IDENTITY-ASSIGN-ACK} message

Information element	Field within the information element	Standard values within the field/information element	Normative action/comment
			All optional

## 12.11.1 Associated procedures

### 12.11.1.1 Timer F-<MM\_ident.1> management

<MM\_ident.1>: TPUI assignment timer;

Value: Refer to EN 300 175-5 [5], annex A;

Start: {TEMPORARY-IDENTITY-ASSIGN} message assigning a TPUI is sent or an interrupting higher priority transaction is completed;

Stop: An indication for link release from the DLC is received.

A {TEMPORARY-IDENTITY-ASSIGN-ACK} or a {TEMPORARY-IDENTITY-ASSIGN-REJECT} message is received, or, interrupting higher priority transaction begins.

## 12.11.2 Exceptional cases

### 12.11.2.1 PT rejects the identity assignment

If the PT is not able to handle the requested Temporary Identity assignment the should reject it.

Table 70: Values used within the {TEMPORARY-IDENTITY\_ASSIGN-REJECT} message

Information element	Field within the information element	Standard values within the field/information element	Normative action/comment
			All optional

## 12.12 Indirect FT initiated link establishment

The procedure shall be performed as defined in EN 300 444 [8], subclause 8.35. The following text together with the associated subclauses defines the mandatory requirements with regard to the present document.

FT and PT shall only support short format for the {LCE-REQUEST-PAGE} message.

**Table 71: Values used within the {LCE-REQUEST-PAGE} message**

Information element	Field within the information element	Standard values within the field/information element	Normative action/comment
<<LCE Header>>			
	<W>	All	For the relation between this field and the <LDE-header> field see EN 300 175-5 [5], subclause 8.2.1
	<LCE-header>	110	lp-error-detect - mandatory
		"111"	lp-error-correct - optional
		"001"	Unknown (MAC service type) & Ringing only relevant for collective/group ringing
<<Short address>>			
	<TPUI Address>	All	Part of the actual TPUI value or/and Ringing information, see EN 300 175-5 [5], subclause 8.2.1

The message shall be inserted in a DL\_BROADCAST-req primitive:

**Table 72: DL\_BROADCAST-req primitive**

Parameter	Information within the parameter	Normative action/comment
<< Cluster address list >>		FT needs to have knowledge as where (in which cluster) the intended PT is located. Alternatively paging may be sent in the whole system
	Data Link Endpoint Identifier	see EN 300 175-4 [4], subclause 7.3.6
<< Message unit >>	LCE-PAGE-REQUEST	
<< Message unit length >>	3 Octets	short paging format
<< Extended message flag >>		Related to the "long" in MAC paging primitives
	Off	
<< Error flag>>		Usually needed for the "ind" primitive
	Off	

## 12.13 Fast paging

In the case that the PP is capable of supporting fast paging, this shall be signalled to the FP by the appropriate coding of the <<Set-up - capabilities>> information element, which shall be transmitted in the {ACCESS-RIGHTS-REQUEST} and {LOCATE-REQUEST} messages, see subclauses 12.11 and 12.12.

If the PT supports fast paging and when the FT in accordance to the FT call establishment management procedures wants to perform a fast paging, see subclause 9, the FP shall transmit the {LCE-REQUEST-PAGE} to DLC included into a DL\_EXPEDITED\_req primitive. At the receiving side the event shall be indicated to the LCE respectively with a DL\_EXPEDITED\_ind primitive. For the possible contents of the related primitives see the contents of DL\_BROADCAST primitive as defined in subclause 12.12.

## 12.14 Collective and Group Ringing

The procedure shall be performed as defined in EN 300 175-5 [5], subclauses 14.4.

## 12.15 Direct FT initiated link establishment

The procedure shall be performed as defined in EN 300 175-5 [5], subclauses 14.2.4. The following text together with the associated subclauses define the mandatory requirements with regard to the present document.

The FT shall only use this procedure if the relevant PT has indicated in its <<Set-up capability>>, see subclause 12.9, that it supports "Fast Set-up". In this procedure there shall be no peer-to-peer NWK layers message exchange.

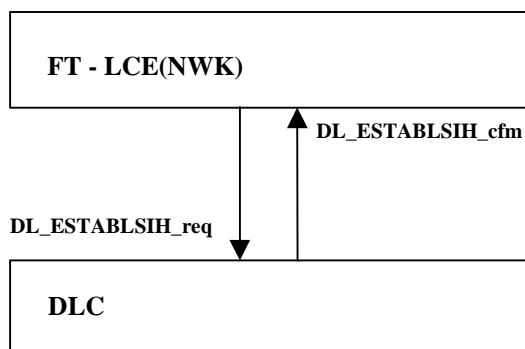

Figure 15: Direct FT initiated link establishment, initiating side

Table 73: Values used within the DL-ESTABLISH-req primitive

Parameter	Information within the parameter	Normative action/comment
<<DLEI>>		
	Data Link Endpoint Identifier	see EN 300 175-4 [4], subclause 7.3.6
<<Establish mode>>		
	Class A operation	
<<Radio Fixed Part (RFP) number>>		FT needs to have knowledge as where (at which RFP) the intended PT is located

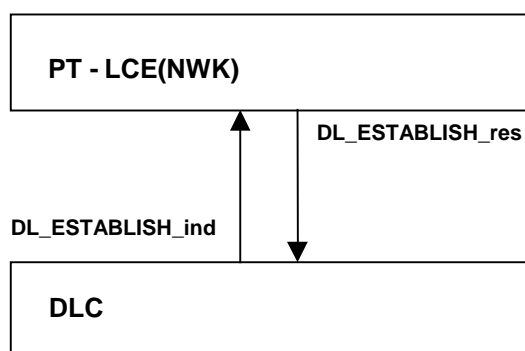

Figure 16: Direct FT initiated link establishment, receiving side

Table 74: Values used within the DL-ESTABLISH-ind primitive

Parameter	Information within the parameter	Normative action/comment
<<DLEI>>		
	Data Link Endpoint Identifier	See EN 300 175-4 [4], subclause 7.3.6
<<Establish mode>>		
	Class A operation	

## 12.15.1 Exceptional case

### 12.15.1.1 Link establishment failure

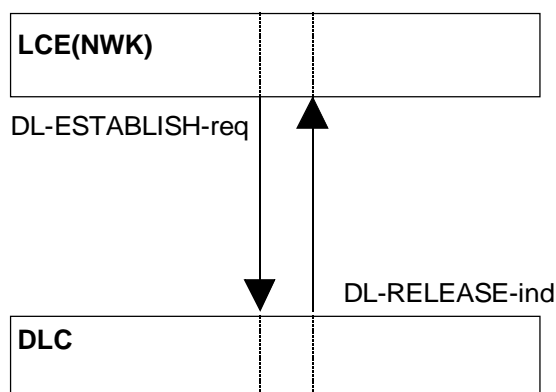

Figure 17: Direct FT initiated link establishment failure

Table 75: Values used within the DL-RELEASE-ind primitive

Parameter	Information within the parameter	Normative action/comment
<<DLEI>>		
	Data Link Endpoint Identifier	See EN 300 175-4 [4], subclause 7.3.6
<<Release mode>>		
	Abnormal	

On receipt of indication for link establishment failure the FT-LCE shall not inform the higher entities requesting the use of the link that the link establishment has failed, shall enter "LINK-RELEASED" state, and shall attempt Indirect Link establishment procedure in accordance to the Call establishment management requirements as specified in clause 9.

## 12.16 Resume Paging

The procedure shall be described as defined in D.3.14 with following clarification:

If MAC layer paging fails (e.g. PP has moved to another cluster) the FT LLME shall request the FT-NWK LCE for initiating a LCE resumption providing the ECN of the related link.

As result the LCE shall construct a Long Page message as defined in EN 300 175-5 [5], subclause 8.2.2 with the following modifications:

**Table 76: Values used within the {LCE-REQUEST-PAGE} message**

Information element	Field within the information element	Standard values within the field/information element	Normative action/comment
<<LCE Header>>			
	<W>	1	
	<LCE-header>	010	Escape
<<discriminator>>		0001	Resume paging
<<Short address>>			
	<TPUI Address>	All	Complete TPUI address
	<spare>	0000	
	<Connection id>	All	The Connection identity of the connection due to resume

NOTE: Connection identity is used in DPRS resume page messages. It contains the NWK layer "connection identity", that equals to the MAC advanced connection LCN.

The message shall be inserted in a DL\_BROADCAST or DL\_EXPEDITED primitive as follows:

**Table 77: DL\_BROADCAST or DL\_EXPEDITED primitive content**

Parameter	Information within the parameter	Normative action/comment
<< Cluster address list >>		FT needs to have knowledge as where (in which cluster) the intended PT is located. Alternatively paging may be sent in the whole system
	Data Link Endpoint Identifier	See EN 300 175-4 [4], subclause 7.3.6
<< Message unit >>		
	LCE-PAGE-REQUEST	
<< Message unit length >>		
	5 Octets	Long paging format - handled as full paging at MAC
<< Extended message flag >>		Related to the "long" in MAC paging primitives
	Off	
<< Error flag>>		Usually needed for the "ind" primitive
	Off	

## 12.17 Broadcast attributes management

RFPs belonging to the same LA shall broadcast the same values of higher layer attributes (see EN 300 175-5 [5], annex F) at any given time.

The Extended Higher Layer Fixed Part Information field shall be used with bit a46 and a45 indicating the support for DPRS frame relay and character oriented service.

In the case that the FP is capable of supporting encryption, this shall use the DECT standard algorithm and shall be signalled to the PP by the setting of the MAC Q-channel Higher Layer Information message bit a37.

The DPRS PP shall be capable to read and interpret at least the following broadcast attributes codings during locking procedure. In the locked state the PP may assume them as static.

**Table 78: Higher Layer Capabilities interpretation by the PP**

BIT Number	Attribute	Value	Note
a36	Standard authentication required	All	
a37	Standard ciphering supported	All	
a38	Location registration supported	All	See location update procedure as an exception.
a40	Non-static FP	All	A FP which is mounted on a moving vehicle.
a44	Access Rights requests supported	All	The FP can toggle this bit to enable or disable on air subscription
a46	Connection handover supported	All	

**Table 79: Extended Higher Layer Capabilities interpretation by the PP**

BIT Number	Attribute	Value	Note
a41	Asymmetric Bearers Supported	All	
a45	DPRS Stream support	All	
a46	DPRS FREL support	All	

## 12.18 U-plane handling

Data calls include service negotiation and as such may have different requirements for connection of the U-plane after some CC-plane data exchange. In any case it shall be kept in mind that there may be service negotiation phase at MAC layer following the negotiation at NWK layer which may require some delay in connection of the U-plane.

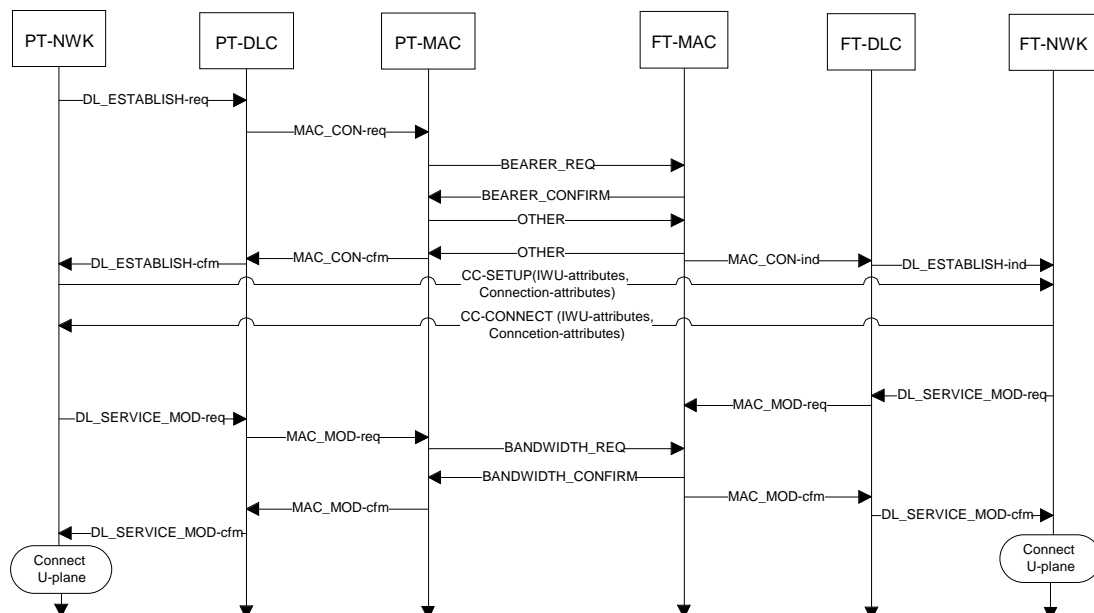
**Figure 18: Example of connection of the U-plane in case of Service negotiation**

NOTE: The transmission of CC-SETUP and CC-CONNECT throughout the layers is not shown. Full contents of messages and primitives is not shown.



## 12.19 Management of MM procedures

The procedure shall be performed as defined in EN 300 444 [8], subclauses 6.9.5 and 13.1. The following text together with the associated subclauses define the mandatory requirements with regard to the present document.

The following table describes whether an MM procedure is supported in any CC state or whether a restriction applies. The restriction has been made in order to limit the complexity of the receiving side so that it is not mandated to understand MM messages in all CC states for the purpose of achieving inter-operability. This table shall be considered in addition to the table included in EN 300 444 [8] subclause 6.9.5.

**Table 80: Support of MM procedures in CC states**

<b>Procedure</b>	<b>Mandatory support in CC state</b>
Detach	F(T)-00
Temporary Identity Assign	F(T)-00

## Annex A (normative): Operating parameters

### A.1 ME operating parameters

#### A.1.1 Constants (applicable to class 1 and class 2 devices)

**Table A.1: Timers T906 and T908**

Timer	Description	value	unit
T906	Time that the real number of bearers have to be lower than the "minimum number of bearers parameter in the "MAC BANDWIDTH" command to consider it a violation of bandwidth.	2	Seconds
T908	Timer that the PP or FP will wait after the unnoticed loss of all bearers received from other side to pass to suspend state	10	DECT Frames

#### A.1.2 Equations

##### A.1.2.1 Waiting time for collision avoidance (WtA)

Formula for waiting time after the end (transition 1->0) of RFP-busy-for data flag (EN 300 175-3 [3], 7.2.4.3.9) to prevent access collisions.

###### A.1.2.1.1 Description

If the RFP had activated the RFP-busy-for-data flag in RFP status (EN 300 175-3 [3], 7.2.4.3.9), after the deactivation of this flag, the PT shall wait a random interval WtA before initiating any bearer setup procedure, to prevent access collisions. In case of access collision during the following PT initiated setup procedure (subclause 10.5.1.1), the PT shall wait a random interval WtA before repeating the access request attempt. In case of successive collisions, formula will be applied with successive increment in the spreading range

###### A.1.2.1.2 Formula

First time:

$$WtA(1) = Rn * T905$$

Successive attempts:  $1 < N \leq 6$

$$WtA(N) = Rn * T905 * 2^{N-1}$$

Successive attempts  $N > 6$

$$WtA(N) = Rn * T905 * 2^5$$

Where N is the number of failures, and Rn is a pseudo-random number in the range 0 to 1, calculated by the PT.

##### A.1.2.2 Waiting time for congestion avoidance (WtB)

Formula for waiting time after a FP bandwidth refuse during a PT resume procedure or a bandwidth modification request.

### A.1.2.2.1 Description

During a PT resume procedure if the FP responds indicating "bandwidth zero", the PT shall release the pilot bearer and wait an interval WtB before repeat the resume procedure. WtB is composed of a fixed part and a random component identical to WtA. In case of successive refusals, formula will be applied with successive increment in the spreading range.

Timer WtB shall be also applied when a PT requests a bandwidth modification that involves increasing the number of bearers, and it is refused by the FT. In such a case, the PT shall not repeat the request of bandwidth extension during an interval WtB.

NOTE: The PT may request bandwidth modification reducing number of bearers at any time.

### A.1.2.2.2 Formula

First time:

$$WtB(1) = T904 + R_n * T905$$

Successive attempts:  $1 < N \leq 6$

$$WtB(N) = T904 + R_n * T905 * 2^{N-1}$$

Successive attempts  $N > 6$

$$WtB(N) = T904 + R_n * T905 * 2^5$$

Where N is the number of failures, and  $R_n$  is a pseudo-random number in the range 0-1, calculated by the PT.

## A.1.3 Variable parameters (class 2 systems only)

### A.1.3.1 Parameters set by the FP (class 2 systems only)

Table A.2: Timers T903, T904, T905 and T910

Timer	Description	Unit	Minimum value	Maximum value	Default value
T903	Maximum time that a PP could wait without transmitting new upstream data or C-plane messages prior to release the Physical Connection	2 DECT Frames =20ms	0	250 (=500 frames)	5 (=10 frames)
T904	Fixed term of the waiting time that a PP should wait after a FP refuse in a PP initiated Physical Connection set up procedure. See equations subclause for formulae.	1 DECT Frame =10ms	0	31	10
T905	Random term of the waiting time that a PP should wait after an access collision or a FP refuse in a PP initiated Physical Connection set up procedure. See equations subclause for formula.	1 DECT Frames =10ms	0	31	10
T910	Handshake procedure timer. A Virtual Call and its associated link and logical connection shall be released if after T910 there has not been any successful handshake between PT and FT.	4 DECT MF's =640ms	1	254+ infinite coded 255 (=1016 MF = 162,56 s)	32 (=128 MF's = 20,48 s)

In class 2 systems, T903, T904, T905 and T910 are chosen by the FP and communicated to the PP's by means of the <<SETUP\_CAPABILITY>> network layer information element. Any PP shall accept any value between minimum and maximum range of the table.

In absence of Network layer communication of the parameter, the default value shall be used.

### A.1.3.2 Negotiable parameters between FP and PP (class 2 systems only)

**Table A.3: Timer T909**

Timer	Description	Unit	Minimum value	Maximum value	Default value
T909	Fast set-up timer: Time in DECT Multiframes to keep the receiver of the PP's in listening for fast set-up mode after any Physical Connection suspend procedure. T909=0 means no fast set-up	1 DECT MF (= 160 ms)	0	254+ infinite coded 255. (40,64 s +infinite)	31 (4,96 sec)

#### A.1.3.2.1 Conditions of negotiation

T909 is negotiable between FP and PP by means of the <<SETUP\_CAPABILITY>> network layer information element according to the following rules:

- if the PP declares to support fast setup in the setup capabilities bit, then it shall accept 4,96 seconds of fast setup timer. Upon this figure, the used value will be the minimum between FP and PP requested values;
- if the PP declares not to support fast setup in the setup capabilities bit, the value of T909 for the PP shall be equal to zero. The value of the network layer information element shall be ignored.

Any PP shall accept any value between and including 0 and 4,96 seconds for the fast setup timer.

---

## A.2 Configuration capabilities for class 1 devices

In order to assure reliable inter-working between devices complying with this profile in mobility class 1, it shall be possible to install the following parameters in the FPs and/or PPs of the system. The values of parameters referring to the PP shall be clearly indicated in the documentation of the PP, and means shall be provided in FPs for such values to be registered. The values of parameters referring to the FP shall be clearly indicated in the documentation of the FP, and means shall be provided in PP for such values to be registered.

**Table A.4: Configuration capabilities for class 1 devices**

Parameter	Value	Configurable in: Fixed(F)/Portable(P)
Service associated with identity	Type A or B	F, P
Data frames	Selected from annex B	F, P
IPUI	Unique value within local environment	F
ARI	Unique value within local environment	P
Maximum supported SDU size	Number of octets	F, P
Multi-bearer capability	1 to 23	F, P
Asymmetric capability	Yes/No	F, P
Diversity capability	Yes/No	F, P
Fast paging available	Yes/No	F, P
Connectionless downlink supported	Yes/No	F, P
Encryption capability	Yes/No	F, P
Static cipher key	64 bits	F, P
T903 Resume timer	0 to 500 DECT Frames	F, P
T904 Wait timer. Fixed part	0 to 31 DECT Frames	F, P
T905 Wait timer. Random part	0 to 14 DECT Frames	F, P
T909 Setup detection timer	0 to 254 DECT Multiframes +infinite	F, P
T910 Handshake procedure timer	0 to 1020 DECT Multiframes +infinite	F, P

## Annex B (normative): Interworking conventions for the Frame Relay (FREL) service

### B.1 Scope of this annex

This annex defines the Interworking conventions for Frame Relay (FREL) service. DPRS Frame Relay Service may be used for the transport of the following protocols:

- ISO 8802-3 (Ethernet) [16];
- ISO 8802-5 (Token Ring) [17];
- Internet Protocol (I<sub>p</sub>) [18];
- Point to Point Protocol (PPP) [19].

Annexes B.1, B.2 and B.3 define a set of conventions applicable to the Frame Relay Service in general, and annexes B.4 to B.7 define the specific conventions for each one of the transported protocols.

#### B.1.1 Typical configuration for the Frame Relay Service

The typical configuration for Frame Relay service is shown in the following figure.

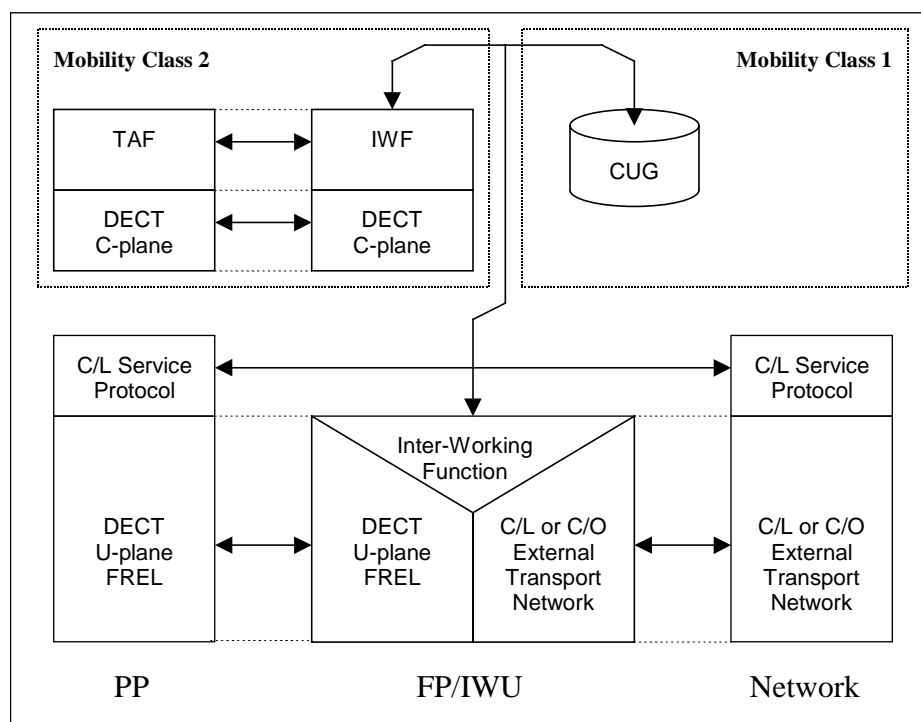

**Figure B.1: Reference configuration for Frame Relay (FREL) Service, including interworking to connection-oriented or connectionless networks**

Mobility class 2 equipment provides a full DECT C-plane, while for mobility class 1 equipment, the C-plane is replaced by a Closed User Group administration.

The specific encapsulation interworking functions are defined in the other clauses of this annex, and are depending on the transported connectionless or connection-oriented protocol. The implementation of the external network used to transport the service protocol outside the DECT system is outside the scope of this profile.

## B.2 Specific codings for mobility class 2

### B.2.1 IWU-Attribute coding

Mobility class 2 equipment, implementing the Interworking Units described in this annex, shall use the following IWU-Attribute coding:

Bit:	8	7	6	5	4	3	2	1	Octet:	
2	0	<<IWU-ATTRIBUTES>>							1	
	Length of Contents (L)									2
	1	CodeStd			Profile					3
	0		1	0	0	0	0	0	0	
	1	Negotiation indicator			Profile subtype					4
	0	Maximum SDU size (Most significant 7 bits)							5	
	1	Maximum SDU size (Least significant 7 bits)							5a	
	1	reserved for profile subtype use							6 (optional)	

Figure B.2: IWU-Attribute Coding

#### Code std (octet 3):

**Bits 7 6 Meaning**  
0 1 Profile defined code

#### Profile (octet 3):

**Bits 5 4 3 2 1 Meaning**  
0 0 0 0 DPRS: Frame Relay services

#### Negotiation indicator (octet 4):

**Bits 7 6 5 Meaning**  
0 0 0 Negotiation not possible;  
0 1 0 Peer attribute negotiation;  
1 0 0 Exchanged attribute negotiation;  
1 1 0 Exchanged attribute negotiation and Peer attribute negotiation;  
All other values are reserved.

#### Profile subtype (octet 4):

##### Frame Relay services (octet 3, bit 1=0):

**Bits 4 3 2 1 Meaning**  
0 0 0 0 ISO 8802-3 [16] (clause B.4);  
0 0 0 1 ISO 8802-5 [17] (clause B.5);  
0 0 1 0 Internet Protocol (I<sub>p</sub>) [18] (clause B.6);  
0 1 0 0 Point-to-Point Protocol [19] (clause B.7)  
All other values are reserved.

#### Maximum SDU size (octets 5 and 5a):

This 14 bit word represents the natural binary coding of the maximum SDU length in units of eight octets used for data transmission, with the least significant bit in position 1 of octet 5a.

### B.2.1.1 Profile subtype byte (byte 6) of <<IWU-attributes>>

The byte 6 of <<IWU-ATTRIBUTES>> shall have a profile subtype specific meaning. The following meaning

#### B.2.1.1.1 ISO 8802-3 (Ethernet)

<b>Bit:</b>	<b>8</b>	<b>7</b>	<b>6</b>	<b>5</b>	<b>4</b>	<b>3</b>	<b>2</b>	<b>1</b>	<b>Octet:</b>
	1	SI <sub>P</sub>	Reserved						6 (optional)

**Figure B.3: Ethernet**

#### SI<sub>P</sub> bit:

This bit indicates if the connectionless downlink service SI<sub>P</sub> is being used (subclause B.4.2.1).

#### Bit 7 Meaning

- 1 SI<sub>P</sub> connectionless downlink is being used
- 0 SI<sub>P</sub> connectionless downlink not used

#### B.2.1.1.2 ISO 8802-5 (Token-Ring)

<b>Bit:</b>	<b>8</b>	<b>7</b>	<b>6</b>	<b>5</b>	<b>4</b>	<b>3</b>	<b>2</b>	<b>1</b>	<b>Octet:</b>
	1	SI <sub>P</sub>	Reserved						6 (optional)

**Figure B.4: Token Ring**

#### SI<sub>P</sub> bit (bit 7 of octet 6):

This bit indicates if the connectionless downlink service SI<sub>P</sub> is being used (subclause B.5.2.2).

#### Bit 7 Meaning

- 1 SI<sub>P</sub> connectionless downlink is being used
- 0 SI<sub>P</sub> connectionless downlink not used

#### B.2.1.1.3 Internet Protocol

<b>Bit:</b>	<b>8</b>	<b>7</b>	<b>6</b>	<b>5</b>	<b>4</b>	<b>3</b>	<b>2</b>	<b>1</b>	<b>Octet:</b>
	1	Reserved					Reserved	6 (optional)	

**Figure B.5: Internet Protocol**

## B.2.2 IWU attributes implemented

Table B.1: IWU attribute support status

Supported parameters						
Field no.	Name of fields	Ref.	Protocol Status	Supp	Values	
					Allowed	Supported
1	ID of IWU attributes of variable length	see note 1	M		18	
2	Length of Contents (L)	see note 2	M		0 to 255	5 to 9
3	Coding standard	see note 2	M		1	
3	Profile	see note 2	M		0	0
4	Negotiation indicator	see note 2	M		0,2	
4	Profile subtype	B.2.1	M		0 to 15	0 to 1, 2,4
5,5a	Maximum SDU size	B.2.1	I	M	0 to 16383	
6	Sl <sub>P</sub> Service	B.2.1.1	I	C.B11	0, 1	
NOTE 1: See 2nd edition of EN 300 175-5 [5], 7.7.1.						
NOTE 2: See 2nd edition of EN 300 175-5 [5], 7.7.21.						
C.B11: O if profile subtype is ISO 8802-3 (Ethernet) or ISO 8802-5 (Token-Ring), else X.						

## B.3 Generic Frame Relay service interworking conventions

The provisions of this subclause shall apply to all applications of the Frame Relay Service.

### B.3.1 DLC U-plane service

The Frame Relay service shall be transported by DLC LU10, (Enhanced Frame Relay Service) with the addition of a SDU checksum of two octets.

### B.3.2 SDU checksum

Each LU10 SDU shall be composed of variable number of bytes of protocol data as defined in each one of the annexes B4 to B.7, plus two bytes of checksum that will be added at the end of the SDU. Checksum shall be used for all Frame Relay services.

The 16-bit checksum shall be identical to that used in DLC C-plane, defined in EN 300 175-4 [4] subclauses 7.9 and 7.10. The checksum shall be calculated over the complete SDU (protocol data + checksum).

The checksum shall provide an error detection capability for the reassembled SDU at the peer side. It does not provide retransmission capability.

### B.3.3 Transmission bit order

All data frames shall always be transmitted as DECT DLC layer SDUs. The Most Significant Bit (MSB) of each octet shall be transmitted first and the Least Significant Bit (LSB) last.

### B.3.4 Support of SDU size

Any DECT equipment supporting any of the DPRS Frame Relay services defined in this annex shall be capable of supporting LU10 SDU frames of at least 1 530 octets, equivalent to 1 528 octets of Frame Relay data plus 2 octets of checksum. The equipment may optionally support larger SDUs.



### B.3.5 SIp connectionless downlink

If the connectionless downlink service (SI<sub>p</sub>) is used, point-to-multipoint and broadcast packets may be transmitted by the connectionless downlink service (SI<sub>p</sub>). These packets may also be transmitted by DECT connection-oriented connections. If the service is not used, all traffic shall be transported by DECT connection-oriented connections.

---

## B.4 ISO 8802-3 (Ethernet)

The provisions of this subclause shall apply if interworking to ISO 8802-3 [16] (Ethernet) LANs is provided.

### B.4.1 Typical configuration

The typical configuration for this specific interworking convention shall be as defined in clause B.1, figure B.1 where the transported protocol is conform to ISO 8802-3 [16].

#### B.4.1.1 Examples of implementation of the external transport network

Implementation of the external network used to transport the ISO 8802-3 [16] frames outside the DECT system is out of the scope of the present document. Typical implementation will be the physical interface of the own ISO 8802-3 [16]. However, alternative implementations are also possible. Some examples of possible implementation and the associated interworking function are given in the following table.

**Table B.2: External network implementation examples**

DPRS Service	External transport network	Referenced standards	IWU Function	Remarks
ISO 8802-3	ISO 8802-3 (any PHY interface)	ISO 8802-3	Bridge	Bridging in IWU.
ISO 8802-3	Frame Relay	Q.922, RFC-1490	Bridge	Bridging function (Ethernet switch) in IWU. ISO 8802-3 [16] over FR as RFC-1490, bridged mode.
ISO 8802-3	Frame Relay	Q.922, RFC-1490.	Switch.	Transparent mapping between each DECT terminal and each FR VC (multiple DLCI's in FR). ISO 8802-3 [16] over FR as RFC-1490, bridged mode

### B.4.2 Specific interworking conventions

The conditions of clause B.3 shall be adhered to in addition to the following:

- the ISO 8802-3 [16] MAC frame shall be transmitted as a single SDU beginning with the ISO 8802-3 [16] MAC Destination Address and ending with the MAC Information field;
- for MAC frames which are less than 64 octets in length, the PAD field shall not be transmitted. This mapping is shown in figure B.6;
- a checksum of two bits shall be added at the end of the SDU as stated by subclause B.3.2.

NOTE: As indicated in clause B.3, The Most Significant Bit (MSB) of each octet shall be transmitted first and the Least Significant Bit (LSB) last.

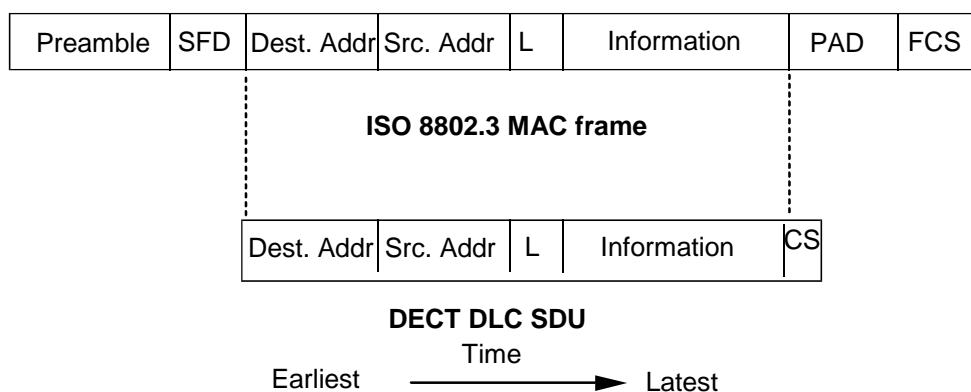

**Figure B.6: Mapping of ISO 8802-3 MAC frames into DECT DLC SDU**

### B.4.2.1 Use of the connectionless downlink $SI_P$ service.

The Connectionless downlink  $SI_P$  service may be used when transporting the ISO 8802-3 [16] (Ethernet) service. The use of this service is indicated by Bit 7 of Octet 6 of <<IWU-ATTRIBUTES>> shown in subclause B.2.1.1.1. If the connectionless downlink service  $SI_P$  is used, the FP is allowed to transmit point-to-multipoint and broadcast packets by the connectionless downlink service ( $SI_P$ ). The FP may also transmit these type of packets by the DECT connection-oriented connections.

If the service is not used, all traffic shall be transported by DECT connection-oriented connections.

### B.4.2.2 Special conventions for mobility class 1 systems

In mobility class 1 equipment IPUIs of type O shall be used, where the full ISO 8802-3 [16] MAC address shall be mapped into the type O IPUI with the Least Significant Bit (LSB) of the ISO 8802-3 [16] MAC address corresponding to the LSB of the IPUI.

## B.5 IEE 802-5 (Token Ring)

The provisions of this subclause shall apply if interworking to ISO 8802-5 [17] (token ring) LANs is provided.

### B.5.1 Typical configuration

The typical configuration for this specific interworking convention shall be as defined in clause B.1, figure B.1 where the transported protocol is conform to ISO 8802-5 [17].

#### B.5.1.1 Examples of implementation of the external transport network

Implementation of the external network used to transport the ISO 8802-5 [17] frames outside the DECT system is out of the scope of the present document. Typical implementation will be the physical interface of the own ISO 8802-5 [17]. However, alternative implementations are also possible. Some examples of possible implementation and the associated interworking function are given in the following table.

Table B.3: Examples of external network implementations

DPRS Service	External transport network	Referenced standards	IWU Function	Remarks
ISO 8802-5	ISO 8802-5	ISO 8802-3	Bridge	Bridging function in IWU.
ISO 8802-5	Frame Relay	Q.922, RFC-1490	Bridge	Bridging function in IWU. ISO 8802-5 [17] over FR.
ISO 8802-5	Frame Relay	Q.922, RFC-1490	Switch.	Transparent mapping between each DECT terminal and each FR VC. Multiple DLCI's in FR.

## B.5.2 Specific interworking conventions

The conditions of clause B.3 shall be adhered to in addition to the following:

- the ISO 8802-5 [17] MAC frame shall be transmitted as a single SDU beginning with the ISO 8802-5 [17] MAC Frame Control (FC) field and ending with the MAC Information field;
- a checksum of two bytes as provisioned by subclause B.3.2 shall be added at the end of the SDU;
- the FP shall not send the token ring MAC Control frames as identified by the FC byte and it shall not send the Frame Status (FS) byte. It shall be the responsibility of the FP to inter-work these to the token ring network. This mapping is shown in figure B.7.

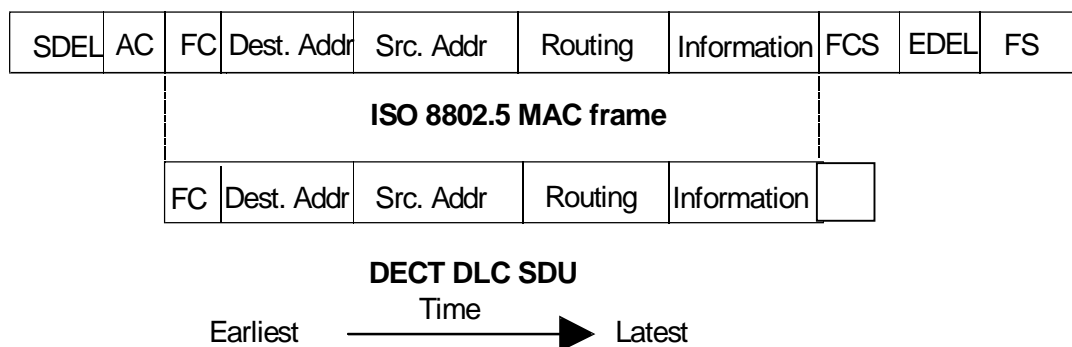

Figure B.7: Mapping of ISO 8802-5 MAC frames into DECT DLC SDU

### B.5.2.1 Special conventions for mobility class 1 systems

In mobility class 1 equipment IPUIs of type O shall be used, where the full ISO 8802-5 [17] MAC address shall be mapped into the type O IPUI with the LSB of the ISO 8802-5 [17] MAC address corresponding to the LSB of the IPUI.

### B.5.2.2 Use of the connectionless downlink SI<sub>P</sub> service.

The Connectionless downlink SI<sub>P</sub> service may be used when transporting the ISO 8802-5 [17] (Token-Ring) service.. The use of this service is indicated by Bit 7 of Octet 6 of <<IWU-ATTRIBUTES>> shown in B.2.1.1.2. If the connectionless downlink service SI<sub>P</sub> is used, the FP is allowed to transmit point-to-multipoint and broadcast packets by the connectionless downlink service (SI<sub>P</sub>). The FP may also transmit these type of packets by the DECT connection-oriented connections.

If the service is not used, all traffic shall be transported by DECT connection-oriented connections.

## B.6 Internet protocol

The provisions of this clause shall apply if interworking to Internet Protocol (IP) version 4 (RFC 791 [18]) or higher is provided.

### B.6.1 Typical configuration

The typical configuration for this specific interworking convention shall be as defined in clause B.1, figure B.1 where the transport protocol is Internet Protocol version 4 (RFC 791 [18]), or higher.

#### B.6.1.1 Examples of implementation of the external transport network

Implementation of the external network used to transport the Internet Protocol outside the DECT system is out of the scope of the present document. Some examples of possible implementations and the associated Interworking function are given in the following table.

**Table B.4: Examples of external network implementations**

DPRS Service	External transport network	Referenced standards	IWU Function	Remarks
IP	Connectionless LAN	ISO 8802-3, ISO 8802-x	Router	IP Routing function in IWU
IP	Frame Relay	Q.922, RFC-1490	Router	IP Routing function in IWU. IP over FR as RFC 1490, routed links.
IP	Frame Relay	Q.922, RFC-1490	Switch	Transparent mapping between each DECT terminal and a FR VC. Multiple DLCI's in FR. IP over FR as RFC 1490, routed links.
IP	ATM	RFC-1483	Router	IP over ATM Adaptation Layer 5
IP	Serial line	PPP RFC-1661, RFC-1662	Router	IP Routing function in IWU. PPP used only in external transport network.

### B.6.2 Specific interworking conventions

The conditions of clause B.3 shall be adhered to in addition to the following:

- IP datagrams shall be transmitted as a single SDU. The SDU contains the IP header followed immediately by the IP data. Since LU10 SDUs can be an arbitrarily short length there are no requirements for adding fill fields or padding;
- a checksum of two octets, as provisioned by subclause B.3.2 shall be added to the end of each SDU.

#### B.6.2.1 Special conventions for mobility class 1 systems

In Mobility class 1 equipment IPUIs of type O shall be used.

## B.7 Point-to-Point Protocol

The provisions of this clause shall apply to transport data encapsulated using the Point-to-Point Protocol (PPP), as defined in RFC 1661 [19].

### B.7.1 Typical configuration

The typical configuration for this specific interworking convention shall be as defined in clause B.1, figure B.1. In this configuration the FP interworking transparently maps any PPP packet coming from a given DECT air interface packet-mode connection to a fixed virtual circuit at the Network interface.

#### B.7.1.1 Examples of implementation of the external transport network

Implementation of the external network used to transport the PPP outside the DECT system is out of the scope of the present document. Some examples of possible implementation are in the following table.

**Table B.5: Examples of external network implementations**

DPRS Service	External transport network	Referenced standards	IWU Function	Remarks
PPP	Modem/PSTN	RFC-1662	Switch	Mapping of C-plane signalling between DECT and PSTN possible
PPP	ISDN (circuit-switch)	RFC-1618	Switch	Mapping of C-plane signalling between DECT and ISDN possible
PPP	Frame Relay	RFC-1973	Switch	PPP over FR.
PPP	ATM	RFC-2364	Switch	PPP over ATM AAL 5
PPP	Tunnel over IP network	L2TP (or PPTP)	Switch	Mapping of C-plane signalling between DECT and L2TP possible

### B.7.2 Specific interworking conventions

The conditions of clause B.3 shall be adhered to in addition to the following:

- the PPP packets, as defined in RFC 1661 [19] shall be transmitted directly as a single U-plane DLC layer SDU. The SDU contains the PPP "protocol field" header followed by the PPP data. The PPP framing, if used (e.g. the one defined in RFC 1662 [20] or other), shall be not transmitted over the DECT air interface;
- a checksum of two octets, as provisioned by subclause B.3.2 shall be added to the end of each SDU;
- the Maximum PPP packet size shall be 1 528 octets, including PPP protocol field.

#### B.7.2.1 Special conventions for mobility class 1 systems

In Mobility class 1 equipment IPUIs of type O shall be used.

## Annex C (normative): Interworking conventions character-oriented services

### C.1 Scope of this annex

This clause specifies the wireless V.24 service conventions applicable for a V.24 service implementation based on the DPRS. The V.24 interface is described in ITU-T Recommendation V.24 [21].

The reference configuration for this interworking is shown in figure C.1a.

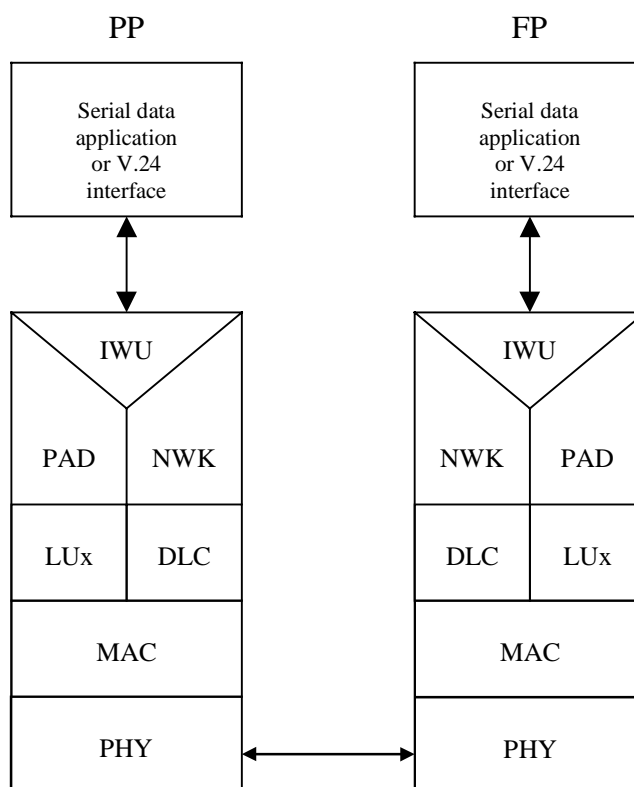

**Figure C.1a: Reference configuration showing the DPRS V.24**

User (and user control) data to be transmitted over the U-plane of the packet mode data profiles is only guaranteed to be protected if passed through the entire U-plane protocol.

After a packet (user or user control data) has been passed to the protection mechanism (LU10) a modification of the content is in general not possible any more as parts of the SDU may already be transmitted over the CI. An expedition of user control frames can only be achieved within the queue on top of the LU10.

**NOTE:** To distinguish user data and user control data, different SAPs including SAP identifiers may be introduced.

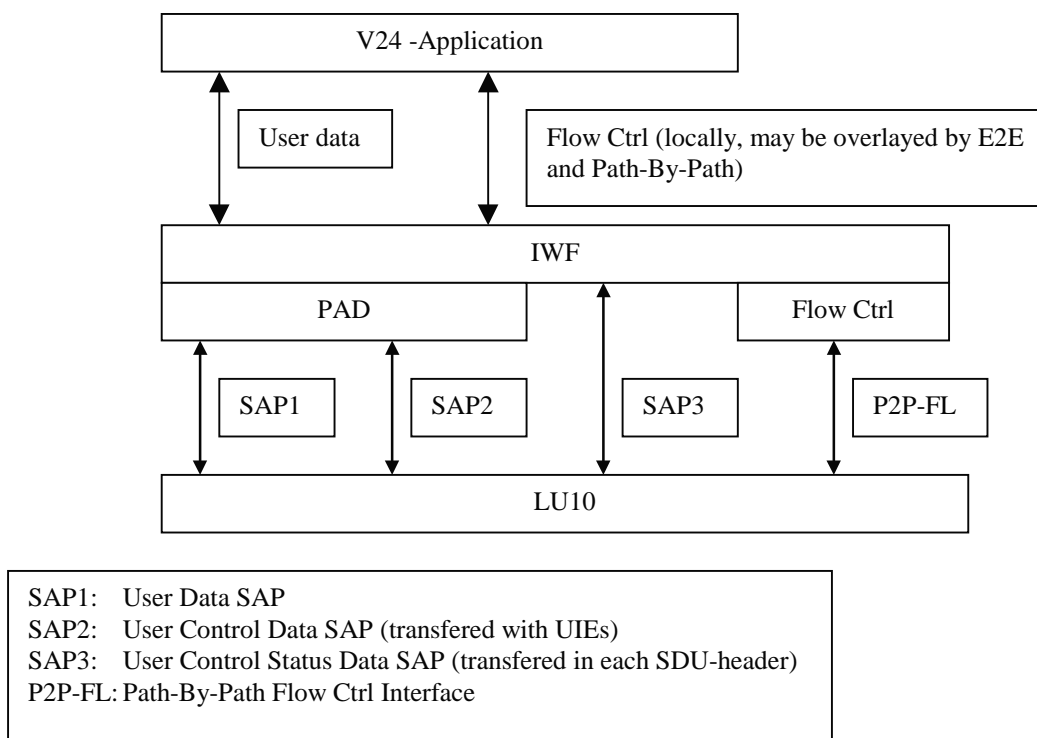

Figure C.1b: SDU Data Flow

The following two scenarios describe different types of V.24-connections. Scenario A shows the normally configuration such as DTE <--> DCE (e.g. computer <--> modem). Scenario B shows a configuration such as DTE <--> DTE (e.g. computer <--> computer). Scenario B is called nullmodem-connection.

DTE: data terminal equipment (e.g. computer).  
 DCE: data circuit-terminating equipment (e.g. modem, ISDN-TA).

### C.1.1 Scenario A

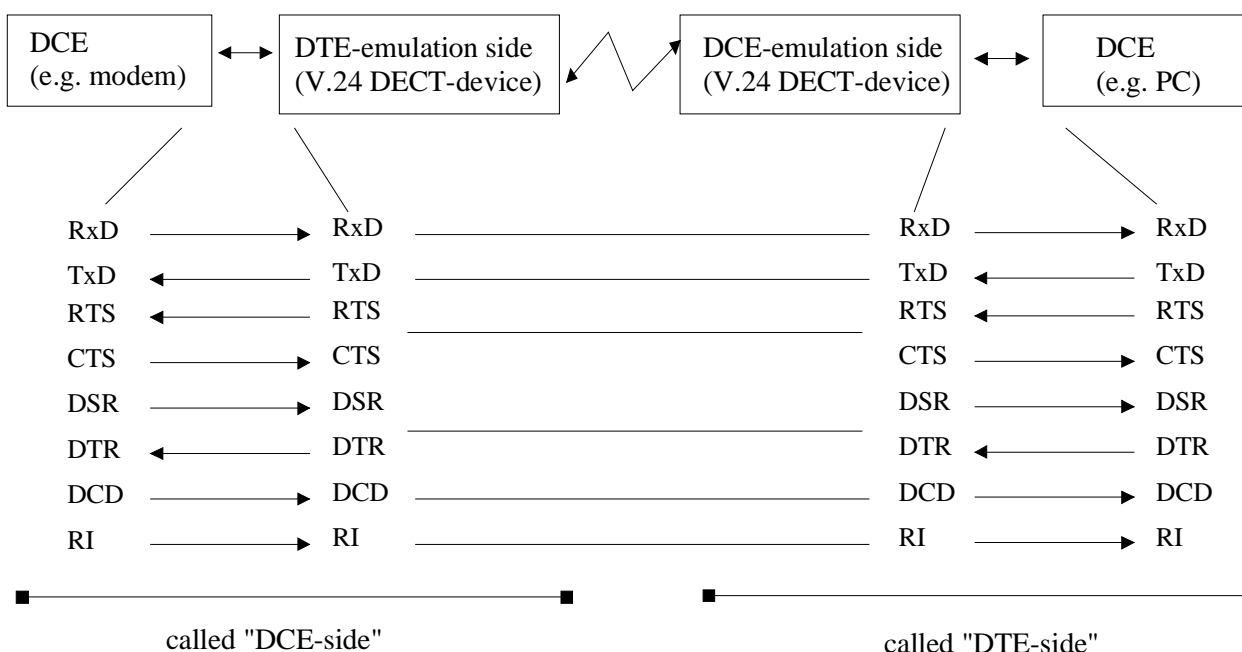

Figure C.1c: Scenario A showing a normally DCE <--> DTE configuration

### C.1.2 Scenario B

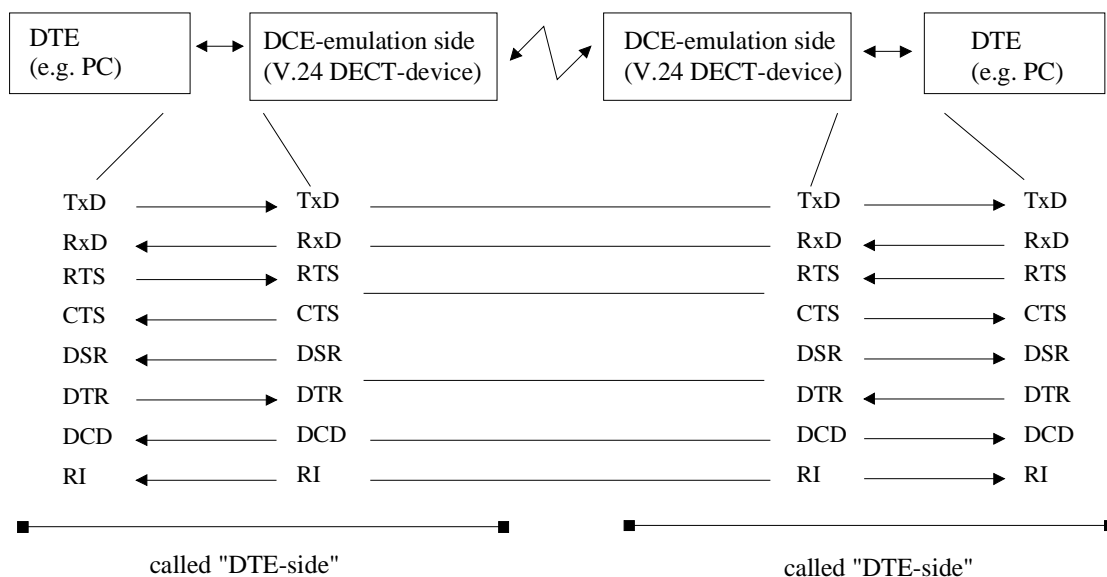

Figure C.1d: Scenario B showing NULL-MODEM configuration

## C.2 Specific coding for mobility class 2

### C.2.1 IWU-Attribute coding

Devices implementing the Interworking Units described in this annex shall use the following IWU-Attribute coding:

Bit:	8	7	6	5	4	3	2	1	Octet:
0	<< IWU-ATTRIBUTES >>								1
Length of Contents (L)									2
1	CodeStd			Profile					3
1	Negotiation indicator			Profile subtype					4
0	Stop bits		Data bits		Parity				5
0	Data rate								5a
1	reserved		Baudrate mode		Flow Control				5b
0	Maximum SDU length (Most significant 7 bits)								6
1	Maximum SDU length (Least significant 7 bits)								6a

Figure C.2: IWU Attribute coding

Profile (octet 3):

Bits 5 4 3 2 1 Meaning  
 0 0 0 0 1 DPRS: character oriented or bit oriented services



**Stop bits coding (octet 5):**

Bits	7	6	Meaning
0	0	0	Not used
0	1		1 bit
1	0		1,5 bits
1	1		2 bits

**Data bits/Parity coding (octet 5):**

Bits	5	4	3	2	1	Meaning
0	0	x	x	x		5 bits
0	1	x	x	x		6 bits
1	0	x	x	x		7 bits
1	1	x	x	x		8 bits
x	x	0	0	0		Odd
x	x	0	1	0		Even
x	x	0	1	1		None
x	x	1	0	0		Forced to 0
x	x	1	0	1		Forced to 1
All other values reserved.						

NOTE 1: The values for the V.24-parameters Data bits and Parity are strongly related. For example: It is possible to support even or none Parity and 7 or 8 data bits, but not in all permutations. Normally you support 8 data bit with no parity and 7 data bits with even or odd parity. So you have always 8 Bit information.

**Examples for Stop bits/Data bits/Parity coding:**

Bits	7	6	5	4	3	2	1	Meaning
0	1	1	1	0	1	1		8N1
0	1	1	0	0	1	0		7E1
0	1	1	0	0	0	0		7O1

**Data rate (octet 5a):**

Bits	7	6	5	4	3	2	1	Meaning
0	0	0	0	0	0	0	0	unspecified
0	0	0	0	1	x	x		$(xx+1) * 50$ bit/s. (50 bit/s to 200 bit/s.)
0	0	0	1	x	x	x		$(xxx+1) * 300$ bit/s. (300 bit/s to 2 400 bit/s.)
0	0	1	x	x	x	x		$(xxxx+2) * 2\ 400$ bit/s. (4 800 bit/s to 40 800 bit/s.)
0	1	x	x	x	x	x		$(xxxxx+1) * 8\ 000$ bit/s. (8 000 bit/s to 256 000 bit/s.) (see note 1)
1	0	x	x	x	x	x		$(xxxxx+6) * 9\ 600$ bit/s. (57 600 bit/s to 35 520 bit/s.) (see note 1)
1	1	0	x	x	x	x		$(xxxx+11) * 24\ 000$ bit/s. (264 000 bit/s to 624 000 bit/s.) (see note 1)
1	1	1	0	0	0	0		75 bit/s.
1	1	1	0	0	0	1		110 bit/s.
1	1	1	0	0	1	0		134,5 bit/s.
1	1	1	0	0	1	1		75 bit/s to 1200 bit/s (see note 2)
1	1	1	0	1	0	0		1200 bit/s to 75 bit/s (see note 2)
All other values reserved.								

NOTE 1: Some bitrates (24 000, 96 000, 144 000, 192 000, 240 000, 288 000, and 336 000 bit/s.) are codeable in several different ways. The different codings are all valid.

NOTE 2: The first rate is the transmit rate in forward direction of the call. The second rate is the transmit rate in backward direction of the call.

**Examples for Data rate:**

<b>Bits</b>	<b>7 6 5 4 3 2 1</b>	<b>Meaning</b>
	0 0 0 0 1 0 0	50 bit/s
	0 0 0 0 1 0 1	100 bit/s
	0 0 0 0 1 1 0	150 bit/s
	0 0 0 0 1 1 1	200 bit/s
	0 0 0 1 0 0 0	300 bit/s
	0 0 0 1 0 0 1	600 bit/s
	0 0 0 1 0 1 1	1 200 bit/s
	0 0 0 1 1 1 1	2 400 bit/s
	0 0 1 0 0 0 0	4 800 bit/s
	0 1 0 0 0 0 0	8 000 bit/s
	0 0 1 0 0 1 0	9 600 bit/s
	0 0 1 0 0 1 1	12 000 bit/s
	0 0 1 0 1 0 0	14 400 bit/s
	0 1 0 0 0 0 1	16 000 bit/s
	0 0 1 0 1 1 0	19 200 bit/s
	0 0 1 1 0 0 0	24 000 bit/s
	0 0 1 1 0 1 0	28 800 bit/s
	0 1 0 0 0 1 1	32 000 bit/s
	0 0 1 1 1 1 0	38 400 bit/s
	0 1 0 0 1 0 1	48 000 bit/s
	0 1 0 0 1 1 0	56 000 bit/s
	1 0 0 0 0 0 0	57 600 bit/s
	0 1 0 0 1 1 1	64 000 bit/s
	1 0 0 0 0 0 1	67 200 bit/s
	1 0 0 0 0 1 0	76 800 bit/s
	0 1 0 1 0 0 0	72 000 bit/s
	0 1 0 1 0 1 1	96 000 bit/s
	1 0 0 0 1 1 0	115 200 bit/s
	0 1 0 1 1 1 0	120 000 bit/s
	0 1 0 1 1 1 1	128 000 bit/s
	1 0 0 1 0 0 1	144 000 bit/s
	1 1 0 1 0 1 0	552 000 bit/s

**Baudrate mode**

<b>Bits</b>	<b>5 4</b>	<b>Meaning</b>
	0 0	Nodynamic detection
	0 1	Dynamic detection at FP
	1 0	Dynamic detection at PP
	1 1	Reserved

**Flow control (octet 5b)**

<b>Bits</b>	<b>3 2 1</b>	<b>Meaning</b>
	0 0 0	No Data Flow Control
	x x 1	Hardware Data Flow Control (RTS/CTS)
	x 1 x	Hardware Data Flow Control (DTR/DSR)
	1 x x	Software Data Flow Control (Xon/Xoff)

NOTE 4: A combination of several Flow control is allowed (for example: RTS/CTS + Xon/Xoff).

## C.2.2 Default-values

It is necessary to have default-values for the V.24-parameters, which can be easily supported by all V.24-devices:

Stop bits:	1
Data bits:	8
Parity:	N
Data rate:	19 200 bit/s
Baudrate mode:	nodynamic detection
Flow control:	no

If dynamic data rate detection is supported the device shall support all data rates of the following list up to and including the negotiated data rate.

300, 600, 1 200, 2 400, 4 800, 9 600, 19 200, 38 400, 57 600, 115 200.

## C.2.3 Negotiation of the V.24-parameters

The FP is the initiating side for the negotiation of the V.24-parameters. The V.24-parameter are negotiated separately. If an V.24-parameters is not negotiated, the default value shall be used. The V.24-parameters should be negotiated call-by-call.

Stop Bits:	The initiating side can suggest any valid value for this V.24-parameter. The receiving side can reject all values except the default value.
Data bits/Parity:	Same as "Stop bits".
Flow control:	Same as "Stop bits".
Data rate:	The initiating side should request any data rate. If the receiving side wants to reject this data rate, it shall answer with the highest supported data rate lower than the requested one. The receiving side is not allowed to reject the default value.

NOTE: The aim of this negotiation is, to negotiate the highest common data rate of both sides as fast as possible. So the "algorithm" is optimized for this aim.

## C.3 Generic interworking conventions

### C.3.1 PAD functionality

This subclause describes the Packet Assembly/Disassembly unit (PAD) functionality for interworking to character oriented (asynchronous) protocols.

### C.3.1.1 Character formatting

Information is transferred between PAD entities using LU10 frames. The LU10 frame Service Data Unit (SDU) has variable length of 1- 1 024 octets. The octets within the LU10 SDU are numbered 0 to n-1, octet 0 is transmitted first. The bits within the octets are numbered 1 to 8, bit 1 is transmitted first. The PAD functions as follows:

Characters are coded into octets in the following way:

- the first bit of the character received/transmitted over the upper PAD interface corresponds to bit position 1 in the octet. The second bit to bit 2, and the eighth bit to bit 8;
- 8 bit characters are transmitted with no padding. Where parity is used it is generated/removed locally;
- 7 bit characters are padded with a "0" in bit position 8. Where parity is used it is inserted in bit position 8;
- 6 bit characters are padded with a "0" in bit positions 7 and 8. Where parity is used it is inserted in bit position 7;
- 5 bit characters are padded with a "0" in bits positions 6, 7 and 8 if no parity is used. Where parity is used it is inserted in bit position 6;
- all start/stop bits are generated/removed locally by the application;
- the character configuration (length, start, stop and parity, etc.) information is conveyed between PAD entities in the {CC-SETUP} message in the <<IWU-ATTRIBUTES>> information element during the call establishment phase;
- characters are inserted into the PAD-buffer in order of transmission in octets 0 to n-1.

### C.3.2 Support of SDU size

All implementations shall support a SDU size of at least the result of the following formula, which depends on the negotiated data rate and other V.24-parameters and shall be calculated at each side. A different value can be negotiated.

The formula:

$$SDU\_size = MAX(29, \frac{data\_rate * (data\_bits + parity\_bits)}{((data\_bits + parity\_bits) + (2 * stop\_bits)) * 8} * t_{TDMA-frame} * (1 + security\_offset) + 1)$$

security\_offset = 7 %

The result of this calculation shall be rounded up to the nearest integer.

A security offset is necessary because of jitter-effects on V.24-interfaces. The value for the security offset is a result of practical experiences.

**Table C.1: values for common data rates and V.24-parameters**

Data rate	Data bits/Parity/Stop bits	Max. supported SDU size
1 200	8N1, 7E1, 7O1	29
2 400	8N1, 7E1, 7O1	29
4 800	8N1, 7E1, 7O1	29
9 600	8N1, 7E1, 7O1	29
19 200	8N1, 7E1, 7O1	29
38 400	8N1, 7E1, 7O1	43
57 600	8N1, 7E1, 7O1	63
115 200	8N1, 7E1, 7O1	125

## C.4 V.24 circuits

### C.4.1 General

The IWU of V.24 DPRS shall support the functionality of CCITT Recommendation V.24 [21] for the following lines:

**Table C.2: IWU V.24 support**

Circuit	Meaning	Direction
103	Transmit Data (TxD)	To DCE
104	Receive Data (RxD)	From DCE
105	Request to Send (RTS)	To DCE
106	Clear to Send (CTS)	From DCE
107	Data Set Ready (DSR)	From DCE
108	Data Terminal Ready (DTR)	To DCE
109	Data Carrier Detect (DCD)	From DCE
125	Ring Indicator (RI)	From DCE

Additional functionality are:

- Xon, Xoff;
- Break and Pause.

NOTE: Indication of break and pause conditions are not foreseen as they are not required for proper operation in nearly all cases.

If supported, the break and pause conditions shall be optional and therefore be transmitted within an optional user control information element as described above.

The V.24 connection establishment shall not influence DECT call control. The call control is only necessary to establish the connection and configure the serial port such as data coding, data rate, etc.

All information (signalling- and user data) of the V.24 connection is transferred via an encapsulation protocol.

### C.4.2 Encapsulation

#### C.4.2.1 Description

For transmission an one byte header is inserted to multiplex signal-, control- or userdata on the same DECT-data link.

#### C.4.2.2 Framing

The framing format is defined as below.

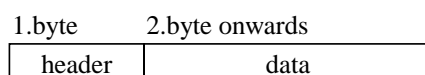

**Figure C.3: Framing of encapsulation**

#### C.4.2.3 Coding of encapsulation

Bit:	8	7	6	5	4	3	2	1
	E	DCD	RI	DTR/DSR	RTS/CTS	Reserved	Reserved	Reserved

**Figure C.4: Header of encapsulation**

The DTR/DSR or RTS/CTS bit respectively indicates that the peer side is not able to receive further data and therefore allows end-to-end flow control (depends on the negotiated type of Dataflow-control). It may be set with respect to the real status of the line and/or by the implementation e.g. due to the buffer status respectively.

NOTE: On the DCE-emulation side is no incoming DCD- or RI-signal from the DTE-device. Therefore the following default values should be set:

RI = 0

DCD = DSR

With these values a proper DCE/DCE-connection (nullmodem) can be guaranteed.

The two bits DTR/DSR and RTS/CTS in the Headerbyte are ambiguous. Therefore we need a rule how the Header shall be interpreted exactly.

#### C.4.2.3.1 DCE-emulation side interpretation

The DCE-emulation side (connected to a DTE) shall interpret received header-bits as follows:

DCD: DCD

RI: RI

DTR/DSR: DSR

RTS/CTS: CTS

#### C.4.2.3.2 DTE-emulation side interpretation

The DTE-emulation side (connected to a DCE) shall interpret the header-bits as follows:

DCD: Ignored

RI: Ignored

DTR/DSR: DTR

RTS/CTS: RTS

### C.4.2.4 SDU Structure

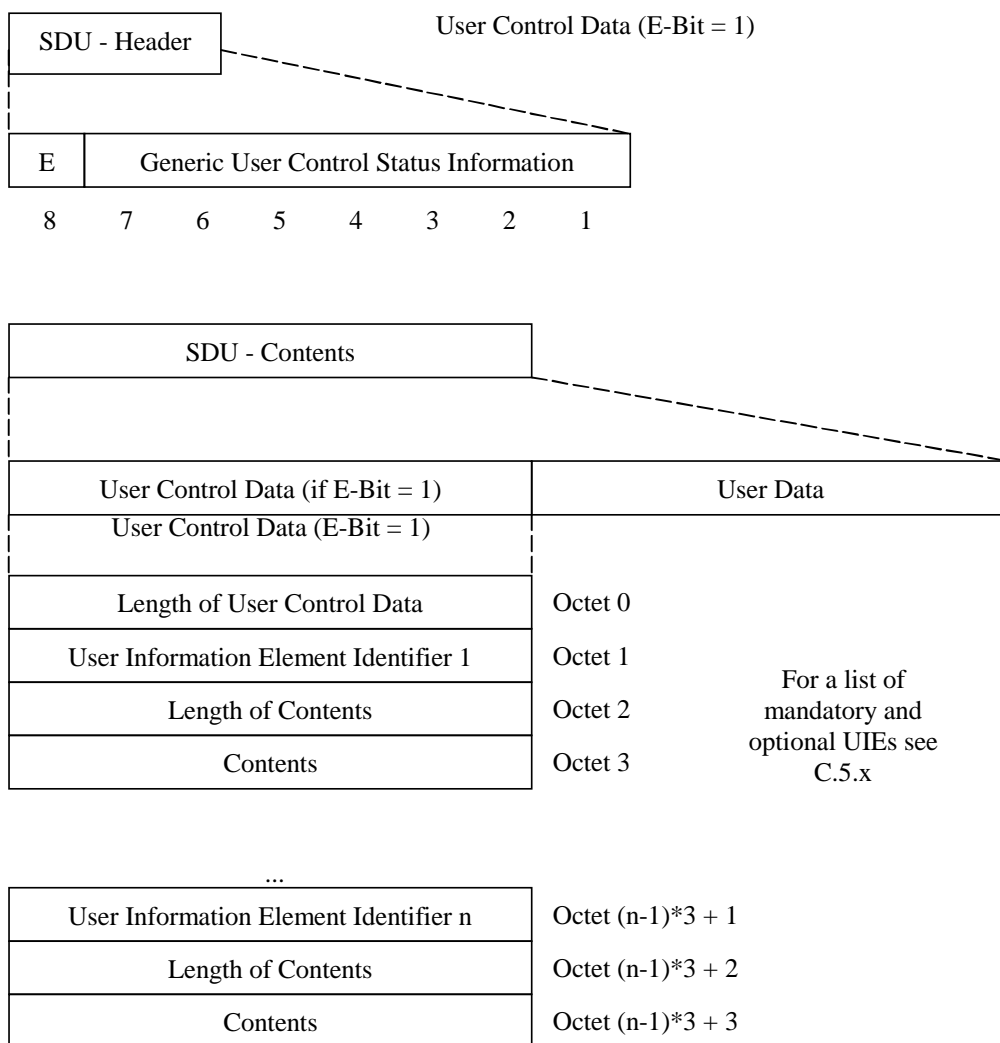

**Figure C.5: Extended field (data) of encapsulation**

The user data is transmitted transparent, but stop and start bits shall not be assembled. These bits shall be generated locally by the application. For 8 bit characters with an additional parity bit, the parity bit shall also be generated locally.

By resetting the extended bit (E = 0), the entire SDU-Contents are equal to the user data.

If the extended bit is set, both user control and user data may be inserted into the extended information field.

The first byte identifies length of directly following user control data. This byte is applied to reroute the user control and user data into the corresponding SAPs (see figure C.1b).

## C.4.3 Interworking procedures and conventions

### C.4.3.1 General

#### C.4.3.1.1 Data forwarding conditions

Userdata and signalling data shall be assembled until one or more of the following conditions is met:

- a timer expires at any time;
- the SDU is forwarded to U-plane service entity.

#### C.4.3.1.2 Dataflow Control

The dataflow shall take action local but shall be overlaid by Path-By-Path or End-2-End Flow Control. Exception: It is not allowed to overlay an active local flow control with an inactive Path-By-Path or End-2-End flow control. The control information shall be generated by U-plane service or set over V.24 interface.

##### C.4.3.1.2.1 Software dataflow control

If the IWU notifies that the U-plane service is not ready to transfer data, it shall generate an Xoff. If the U-plane service indicates the data should be transmitted once again the IWU shall generate an Xon.

If the IWU notifies that an Xoff is received by V.24 interface, the IWU shall stop to transmit data over V.24 interface. If the Xon identify is received at V.24 interface the IWU start to transmit once again.

##### C.4.3.1.2.2 Hardware dataflow control

The flow control condition indication shall be performed using circuits RTS/CTS or circuits DTR/DSR, in these cases:

At DCE-emulation side IWU interface (connected to a DTE):

- a DCE-emulation side IWU not-ready condition, initiated U-plane service, shall be indicated by turning circuit 106 (CTS) or 107 (DSR) OFF and cleared by turning circuit 106(CTS) or 107(DSR) ON;
- a DTE not ready condition shall be recognized by an ON-OFF transition and cleared by an OFF-ON transition of circuit 105 (RTS) or 108 (DTR).

At DTE-emulation side IWU interface (connected to a DCE):

- a DTE-emulation side IWU not-ready condition, initiated U-plane service, shall be indicated by turning circuit 105 (RTS) or 108 (DTR) OFF and cleared by turning circuit 105 (RTS) or 108 (DTR) ON;
- a DCE not ready condition shall be recognized by an ON-OFF transition and cleared by an OFF-ON transition of circuit 106(CTS) or 107(DSR).

NOTE: on running system, either DTR/DSR or RTS/CTS mode is available. This is set in the IWU-Attribute

##### C.4.3.1.3 Transmission of U-plane data procedure

If the SDU is forwarded to U-plane service entity, the actual line states of V.24 are inserted into the header (done by the application).

##### C.4.3.1.4 Receive of U-plane data procedure

The header is to compare if line states of V.24 connection have been changed.



#### C.4.3.1.5 V.24 signalling

The circuits 106 (CTS) /105 (RTS) or 107 (DSR)/108 (DTR) shall be generated locally and maybe overlaid by Path-By-Path or End-2-End flow control.

#### C.4.3.1.6 Configuration a V.24 interface during a Connection

##### The initiating side:

The IWU shall stop the user data transmission by using the dataflow control, it sends also the remaining data into transmit buffers and shall issue MMCC\_MODIFY.req, specifying the configuration of serial interface and link, and shall await a MMCC\_MODIFY.cfm primitive. If this primitive notifies failure, it shall enter the release-procedure, otherwise the dataflow control enable the data flow.

##### The destination side:

If the IWU receives a MMCC\_MODIFY.ind, it shall stop the data transmission by using the dataflow control, afterwards the buffer shall be cleared, the serial port shall be configure and shall await incoming data of the initiating side.

NOTE: It is not necessary in all MNCC\_MODIFY-events to stop the data transmission etc. (for example: bandwidth-modification).

#### C.4.3.2 Fall back procedure

If the DECT-Link breaks off, the DCE-emulation side IWU shall clear the buffer and turn circuit 107 (DSR)/106 (CTS), circuit 125 (RI) and circuit 109 (DCD) off, the DTE-emulation side IWU shall clear the buffer and turn circuit 108 (DTR) and circuit 105 (RTS) off.

#### C.4.3.3 Procedure at the DCE-emulation side IWU

The IWU shall emulate a DCE. Received Data (from the air-interface) shall be forwarded via the circuit RxD to the DTE and V.24-data shall be received via the circuit TxD from the DTE. (see figure C.1c for details).

NOTE: The dataflow control is not special notified. It is defined in C.4.3.1.2.

##### C.4.3.3.1 DTE- initiated VC establishment

If no V.24 call is established, then the IWU shall monitor the value of all state-lines. If DTR line goes ON, the IWU shall monitor the activity of the circuit TxD. The circuit TxD shall also be monitored, if no dataflow mode is negotiated. If data is detected on the circuit TxD line or a state on the state-lines is changed, then the IWU shall issue an MNCC\_SETUP.req primitive and change the state to "V.24 call Requested".

In the "V.24 call Requested" state, if the IWU receives a MNCC\_REJECT.ind primitive, it shall clear the buffer and set DSR-, CTS-, RI- and DCD-line OFF and shall return to the "No V.24 call" state. Its subsequent action shall be locally determined on the basis of the release reason contained in the primitive.

In the "V.24 call Requested" state, if the IWU receives an MNCC\_CONNECT.ind primitive it shall enter a "V.24 call Active" state. Other primitives might be received before MNCC\_CONNECT.

##### C.4.3.3.2 DCE-initiated VC establishment

Upon the receipt of a MNCC\_SETUP.ind primitive, the IWU shall determine that the service requested may be offered, and if so it will issue a MNCC\_CONNECT.ind primitive and enter the "V.24 call Active" state. Other primitives might be sent before MNCC\_CONNECT.

If the service cannot be supported, it will issue a MNCC\_REJECT.req, indicating a release reason, and will return to the "No V.24 call" state.

#### C.4.3.3.3 V.24 call release

The application shall decide in which cases the V.24 call should be released. The V.24 call release shall be done using the NWK Call release procedure (see GAP).

#### C.4.3.4 Procedure at the DTE-emulation side IWU

The IWU shall emulate a DTE. Received data (from the air-interface) shall be forwarded via the circuit TxD to the DCE and V.24-data shall be received via the circuit RxD from the DCE (see figure C.1c for details).

##### C.4.3.4.1 DCE-initiated VC establishment

If no V.24 call is established, then the IWU shall monitor the value of all state-lines. If the DSR line goes ON, then the IWU shall monitor the activity of the circuit RxD. The circuit RxD shall also be monitored, if no dataflow mode is negotiated. If data is then detected on the circuit RxD line, or any state line is changed, then the IWU shall issue an MNCC\_SETUP.req primitive and shall enter the "V.24 Call Requested" state.

In this state, if the IWU receives a MNCC\_REJECT.ind primitive, it shall clear the buffer and shall return to the "No V.24 Call" state. Its subsequent action shall be locally determined on the basis of the release reason contained in the primitive.

In the "V.24 Call Requested" state, if the IWU receives an MNCC\_CONNECT.ind primitive it shall enter a "V.24 Call Active" state. Other primitives might be received before MNCC\_CONNECT.

##### C.4.3.4.2 DTE-initiated VC establishment

Upon the receipt of a MNCC\_SETUP.ind primitive, the IWU shall determine that the service requested may be offered, and if so it will issue a MNCC\_CONNECT.ind primitive and enter the "V.24 Call Active" state. Other primitives might be sent before MNCC\_CONNECT.

Once in this state, it shall set the value of the DTR line to the value communicated to it by U-plane service. If the service cannot be supported, it will issue a MNCC\_REJECT.req, indicating a release reason, and will return to the "No V.24 Call" state.

##### C.4.3.4.3 V.24 call release

The application shall decide in which cases the V.24 call should be released. The V.24 call release shall be done using the NWK Call release procedure (see [8]).

## C.5 Definition of User Control Information Elements

UIEs can be send within each SDU. It is allowed to send user data and UIEs in one SDU (see subclause C.4.2.4).

### C.5.1 Mandatory UIEs

No mandatory UIEs at this time.

### C.5.2 Optional UIEs

A device can send the UIE <release\_reason> at any time. If a device receives this UIE it can decide how to react.

UIE\_RELEASE\_REASON:

Field	Code	Comment
Tag	UIE_RELEASE_REASON	Release Reason
Length	1	1 byte following
Value	Bits 8 7 6 5 4 3 2 1 0 x x x x x x x 1 0 0 0 0 0 0 0 All other values reserved.	Proprietary reasons Reason not known

Some operating systems (e.g. Unix) sometimes use a special behaviour of the start- and stop-bit. To support this behaviour, the following two UIEs are necessary.

BREAK\_CONDITION:

Field	Code	Comment
Tag	UIE_BREAK_CONDITION	Break Condition
Length	1	1 byte following
Value	0 to 255	Unit: 10 milliseconds

PAUSE\_CONDITION:

Field	Code	Comment
Tag	UIE_PAUSE_CONDITION	Pause Condition
Length	1	1 byte following
Value	0 to 255	Unit: 10 milliseconds

### C.5.3 Information Element Identifier

Information Element Identifier (Tag):

Bits	8 7 6 5 4 3 2 1	Meaning
	0 x x x x x x x	proprietary UIEs
	1 0 0 0 0 0 0 1	UIE_BREAK_CONDITION
	1 0 0 0 0 0 1 0	UIE_PAUSE_CONDITION
	1 0 0 0 0 0 1 1	UIE_RELEASE_REASON

All other values reserved.

## Annex D (normative): Amendments to EN 300 175

The following amendments apply to EN 300 175 for the purpose of the present document. Revision marks are used where appropriate.

### D.1 Amendments to EN 300 175-3

#### D.1.2 MAC resume page message

##### D.1.2.1 MAC page message (add to subclause 7.2.4.1 of EN 300 175-3)

###### D.1.2.1.1 P<sub>T</sub> format for MAC\_resume page message (7.2.4.1.4)

P <sub>T</sub> Header=x011	PMID (20 bits)	ECN	Reserved
a8 a11	a12 a31	a32 a35	a36 a47

Figure D.1 ( New MAC figure): P<sub>T</sub> format for MAC\_resume page message

Include the information of the following table in EN 300 175-3.

Table D.1: Values used within MAC resume page message format

MAC message	Field within the message	Standard values within the MAC message	Normative action/comment
<<Pt MAC resume page format>>			
	<Pt-header extend flag > (a8)	0,1	a8 = 1 means another page message shall start in the next frame in this multiframe that is permitted to contain a Pt type.
	<BS SDU length indication> (a9 to a11)	011	MAC resume page
	<PMID>(a12 to a31)	All	PMID
	<ECN> (a32 to a35)	All	Exchanged connection number
	(a36 to a47)	1111 1111	Reserved

###### D.1.2.1.2 B<sub>S</sub> SDU length indication (7.2.4.2.3)

Table D.2

a <sub>9</sub>	a <sub>10</sub>	a <sub>11</sub>	Length indication
0	0	0	Zero length page
0	0	1	Short page
0	1	0	full page
0	1	1	MAC resume page
1	0	0	not the last 36 bits of a long page
1	0	1	the first 36 bits of a long page
1	1	0	the last 36 bits of a long page
1	1	1	all of a long page (first and last)

On receipt of the paging message the PT shall start bearer establishment by sending a B\_field Bearer\_Request (advanced, ECN= 0000).

To provide information to PT to which suspended connection the resumption is related the FT shall response with a B-field Bearer\_Confirm (advanced, ECN =the true ECN related to the connection to be resumed).

### D.1.3 Bearer and connection control (7.3.4.2)

Change the parameters of the following commands.

**Table D.3: Bearer and connection control**

command				param_1	param_2	Meaning
0	0	0	0	LBN LBN	LBN LBN	antenna switch for the single bearer identified by LBN request: PT --> FT reject: FT --> PT
0	0	1	0	0000 LBN	LBN LBN	bearer handover of the bearer identified by LBN request: FT --> PT reject: PT --> FT
0	0	1	0	1111 LBN	LBN LBN	bearer handover of the bearer identified by LBN request: PT --> FT reject: FT --> PT

NOTE: Duplicate the last used LBN to all not used LBN parameter fields to ensure detection capability for the receiver. Values 0000 and 1111 can be ignored.

### D.1.4 Unilateral jump procedure

#### D.1.4.1 Bearer quality in an asymmetric connection (7.3.4.4)

This is the "MAC-Mod2-ACKs" message.

								Acknowledgements for				acknowledgements for											
X	0	1	1	1	1	1	1	Channels in the first				channels in the second											
								Half of the frame				half of the frame											
bn <sub>0</sub>				bn <sub>7</sub>				bn <sub>8</sub>				bn <sub>35</sub>				bn <sub>36</sub>				bn <sub>63</sub>			

**Figure D.2**

Acknowledgements for physical channels in the first half of the TDMA frame.

LBN1		LBN2		LBN3		LBN4		LBN5		...	LBN14	
Q1/	Q2	Q1/	Q2	Q1/	Q2	Q1/	Q2	Q1/	Q2		Q1/	Q2
BCK		BCK		BCK		BCK		BCK			BCK	
bn <sub>8</sub>		Bn <sub>9</sub>		bn <sub>10</sub>							bn <sub>35</sub>	

**Figure D.3**

Acknowledgements for physical channels in the second half of the TDMA frame.

LBN1		LBN2		LBN3		LBN4		LBN5		...	LBN14	
Q1/	Q2	Q1/	Q2	Q1/	Q2	Q1/	Q2	Q1/	Q2		Q1/	Q2
BCK		BCK		BCK		BCK		BCK			BCK	
bn <sub>36</sub>											bn <sub>63</sub>	

**Figure D.4**

In pairs two bits are related to one simplex half of a double simplex bearer identified by the LBN. Depending on the MAC layer service the meaning of these bits is different.

For  $I_N$  and  $I_P$ \_error\_detection services the two bits have the function of the Q1 and Q2 bit. The setting of the Q1 and Q2 bit are described in the procedures of subclause 10.8.1.3.

For the  $I_P$ \_error\_correction service the two bits have the function of the BCK and Q2 bit. The coding of these bits are described in subclause 10.8.2.4.

### D.1.4.2 General (10.6.1)

The MAC layer provides PTs and FTs with several mechanisms to control the quality of transmissions and receptions. Bearer handover may be initiated either by using this quality information or by receiving a bearer handover request message from the far end (see subclauses 7.2.5.5 and 7.2.5). For duplex bearers the PT only can initiate a bearer handover, and for double simplex bearers the transmitting side only can initiate a bearer handover. The existing bearer can be maintained until the new bearer has been established. During bearer handover the two bearers can operate in parallel.

NOTE 1: Bearer handover requires that an MBC for the connection exists on both sides, PT and FT, and that the new selected RFP at the fixed side belongs to the same cluster.

PTs should use bearer handover to attempt to connect to the best RFP of the cluster in which the connection is established. This may be the same RFP as the existing bearer, or may be a new RFP.

DECT equipments may have several indicators to monitor reception quality:

- the A-field CRC;
- the X-field CRC;
- the  $CRC_S$  of the B-subfields in protected mode (E-type or U-type for  $I_P$ );
- X-field to Z-field comparison (for Z-field refer to EN 300 175-2 [2]);
- link identity information;
- synchronization pulse;
- clock jitter;
- signal strength.

To control the quality of transmissions the MAC layer uses the reports from the far end, coded in two bits:

- the (Q1,Q2) bits; or
- the (BCK,Q2) bits (see subclauses 7.1.1 and 7.3.4.4).

There are no specified rules for the PT which define when a bearer handover attempt has to be made. For system reasons the maximum rate at which bearer handovers can be performed is limited by a simple timer. No more than two successful bearer handovers should occur within T202 seconds.

NOTE 2: This should not be confused with multiple attempts for one handover.

NOTE 3: For bearer handover (both intra- and inter-cell) in multibearer connections, each bearer is treated separately.

Different handover procedures exist for duplex and double simplex bearers.

### D.1.4.3 Q2 bit settings (10.8.1.3.1)

For duplex bearers the Q2 bit is the bit  $a_7$  of the A-field header. This bit is used for  $C_S$  and  $C_F$ -channel flow control and may also be used to report bearer quality. The Q2 bit shall be set in response to the last received databurst on this bearer.

The quality of double simplex bearer shall be reported with the bearer quality control message defined in subclause 7.3.4.4. This message provides a Q2 bit for each simplex bearer. The location of the Q2 bits depends on the logical bearer number (LBN). The Q2 bits reserved for established double simplex bearers shall be set according to the last known quality results. The Q2 bits reserved for non-existing double simplex bearers shall be set to "0".

NOTE 1: No C-channel data is transmitted on double simplex bearers.

NOTE 2: For double simplex bearers the bit  $a_7$  of the A-field header is always set to 0.

NOTE 3: During bearer handover of a double simplex bearer the values of the Q2 bits for this logical bearer should be ignored.

Rules for Q2 bit setting:

- a) the Q2 bit is set to "0" whenever the A-field CRC failed. If the A-field CRC passes the Q2 bit setting is determined by the rules b) or c);
- b) when a set of  $C_F$  segments was received (correct A-field and BA bits indicate E-type with  $C_F$ ) the Q2 bit setting depends on the  $C_F$  data only. Setting the bit to "1" indicates an acknowledgement for this set of  $C_F$  data (duplex bearer only);
- c) if the B-field contains an  $I_p$  segment the Q2 bit shall be set to "1";
- d) if the B-field contains an  $I_N$  segment or only MAC control (see BA bit setting in the A-field header) the Q2 bit setting depends on the transmission direction:
  - d.1) **Data from FT to PT, Q2 from PT to FT:** The Q2 bit shall be set to "1";
  - d.2) **Data from PT to FT, Q2 from FT to PT:** The Q2 bit may either be set to "1" or report if the B-field data were accepted. In the latter case the Q2 bit shall be set to "1" for accepted B-field data and to "0" for rejected B-field data. It is the manufacturer's freedom to define the rules for accepting B-field data.

Notes to rule d.2):

NOTE 4: Manufacturers should set the Q2 bit according to B-field data acceptance. This option enables PTs to initiate a bearer handover whenever the bearer quality is bad. Tests may be based e.g. on the X-field CRC result or on  $R_B$  CRC results of B-subfields if MAC control was received.

NOTE 5: Q2 set to "1" is also an acknowledgement for received  $C_S$  data (duplex bearers only). If the setting of the Q2 bit depends on the acceptance of B-field data the Q1 bit setting option to report the A-field CRC result should also be applied. Otherwise the  $C_S$  data throughput may suffer.

## D.1.4.4 MOD-2 protected I-channel operation ( $I_P$ ) (10.8.2)

### D.1.4.4.1 General (10.8.2.1)

The modulo-2 procedure uses a 2-state packet number in the A-field header. This packet number applies to the complete B-field of  $I_P$  data. The first  $I_P$  packet sent on a new logical bearer is labelled with packet number "1".

Successful reception of the data is acknowledged independently for each logical bearer. For duplex bearers the acknowledgement mechanism uses the Q2 and the BCK bits in the return A-field header. For double simplex bearers, these bits, the Q2 and BCK bits, for each logical simplex bearer are multiplexed into a "MAC-MOD2-ACKS" message, and this message is sent in at least one B-subfield on at least one reverse bearer.

MOD-2 operation in the asymmetric case shall use the E32-mux or the E80-mux in the reverse direction.

NOTE: The MOD-2 receiver may use selective reception, or even majority voting to achieve CRC success.

### D.1.4.4.2 Use of the acknowledge bits (10.8.2.4)

During MOD-2 operation two bits are used for  $I_P$ -channel flow control. These bits are located in different positions for duplex and double simplex bearers. The two bits are:

- the Q2 bit and the BCK bit in the A-field header at positions  $a_3$  and  $a_7$  as described in subclause 7.1 for a duplex bearer;
- two pairs of an Q2 and a BCK bit in the quality control message described in subclause 7.3.4.4 for a double simplex bearer.

The settings of the Q2 bit is described in subclause 10.8.2.4.1.

The setting of the BCK bit is described in subclause 10.8.2.4.2.

The two control bits Q2 and BCK in the A-field shall be set individually for each duplex bearer of a symmetric or an asymmetric connection.

The two control bits Q2 and BCK in the quality control message shall be set individually for each logical half of a double simplex bearer in asymmetric connections. The Q2 bits for non-existing logical double simplex bearers shall be set to "0" and the BCK bits to "1".

During bearer handover of a double simplex bearer, the acknowledge results for the old and the new bearer (bearers with the same LBN) should be combined to produce a single set of results.

NOTE: It is not allowed to transmit two different  $I_P$  segments in the same TDMA half frame on the "new" and the "old" double simplex bearer during bearer handover (see subclause 10.6.3).

### D.1.4.4.3 Q2 bit setting for $I_P$ \_error\_correction services (10.8.2.4.1)

#### Q2 bit setting for duplex bearer

The Q2 bit setting influences the retransmission mechanism from  $C_S$ ,  $C_F$  and  $I_P$  data. The setting of the Q2 bit is exactly the same as in  $I_P$ \_error\_detection services (see subclause 10.8.1.3.1).

NOTE: When an  $I_P$  segment was received (A-field CRC correct and the BA bits set to  $I_P$  segment with number 0 or 1) the Q2 bit is set to "1", regardless of the results of the B-field CRCs. The MOD-2 retransmission scheme assumes for proper operation, that the packet number of the  $I_P$  segment is then known to the  $I_P$  data receiver.



**Q2 bit setting for double simplex bearer:**

Data received on a double simplex bearer is acknowledged on another bearer in reverse direction. The reverse bearer provides an Q2 bit for each simplex bearer in forward direction.

The Q2 bit on the reverse bearer does not influence the  $C_S$  and the  $C_F$  retransmission scheme and is set as follows:

- when an  $I_P$  segment was received (A-field CRC correct and the BA bits set to  $I_P$  segment with number 0 or 1) the Q2 bit is set to "1", regardless of the results of the B-field CRCs.

Exception: When receiving a RESET message (during a  $I_P$  bearer reset procedure, see subclause 10.8.2.5.3) the Q2 bit shall be reset to "0".

**D.1.4.4.4 Unilateral jump (10.8.2.5.2)**

The unilateral jump process is described with two state tables, one for the transmitter, and one for the receiver.

**Receiver:**

The three state variables at the receiver are:

- LAST-BCK meaning "what packet number was transmitted in the last BCK bit to indicate the number of the next expected  $I_P$  segment";
- LAST-PKT meaning "what  $I_P$  packet number appeared in the last databurst containing  $I_P$  data";
- THIS-PKT-NO meaning "what  $I_P$  packet number appears in the databurst just received containing  $I_P$  data".
- NEXT-PK-NO meaning "what  $I_P$  packet number the Receiver shall ask for in the next burst".
- The variables LAST-PKT and THIS-PKT-NO can take three values: "0", "1" and "unknown". The value "unknown" is produced if it not possible to determine the  $I_P$  packet number appeared in the databurst. This situation is produced, for instance, when the CRC of A-field is incorrect.

The Receiver, after evaluating the received  $I_P$  packet (see subclause 10.8.2.3.) evaluates the state variables following table D.4 to know how the Transmitter acted; after that, it evaluates the Rb-CRCs of all the B subfields and shall act as indicated in table D.5.

**Table D.4**

	THIS-PKT=LAST-PKT	THIS-PKT=LAST-BCK	How transmitter acted
(a)	yes	Yes	Retransmit
(b)	no	Yes	normal advance
(c)	yes	No	unnecessary retransmit
(d)	no	No	Jump
(e)	Unknown	Yes	Either retransmit or advance
(f)	Unknown	No	Either retransmit or jump
(g)	Unknown	Unknown	Unknown

NOTE 1: the states (e), (f) happens when LAST-PKT is unknown and the state (g) when THIS-PKT is unknown.

Table D.5

Table D.4 state	Rb-CRC result	how Receiver shall act
(g)	Not considered	NEXT-BCK = LAST-BCK
(a), (b), (e)	Rb-CRCs passed	NEXT-BCK = LAST-BCK + 1 (MOD 2)
(a), (b), (e)	Rb-CRCs failed	NEXT-BCK = LAST-BCK
(c)	Rb-CRCs passed	NEXT-BCK = LAST-BCK; RX still requires the same I <sub>p</sub> packet
(c)	Rb-CRCs failed	NEXT-BCK = LAST-BCK; RX still requires the same I <sub>p</sub> packet
(d), (f)	Rb-CRCs passed	NEXT-BCK = LAST-BCK
(d), (f)	Rb-CRCs failed	NEXT-BCK = LAST-BCK + 1 (MOD 2)

NOTE 2: In cases (e) and (f), the receiver can not be sure what was the action in the TX side. In these cases the packet should be delivered to the DLC layer.

#### Transmitter:

Define: **LT<sub>I<sub>p</sub></sub>** = packet number of the last transmitted I<sub>p</sub> segment.

The two state variables at the transmitter are:

- **ACKN** meaning "an I<sub>p</sub> packet has been received in the receiver last databurst":
  - for duplex bearer the reception of the I<sub>p</sub> packet is acknowledged by receiving an A-field correct and with the Q2 bit set to 1 (see subclause 10.8.2.4.1);
  - for double simplex bearer the reception of the I<sub>p</sub> packet is acknowledged by receiving an A-field correct and with Q1 bit set to 1 (see subclause 10.8.2.4.1).

NOTE 3: For double simplex bearer this process is independent for both simplex bearers.

- **LAST-BCK** meaning "what was the setting of the last correct received BCK bit (with the BCK bit the receiver reports the next expected I<sub>p</sub> packet)?".

NOTE 4: If ACKN switches to "yes" also a new BCK is received.

Table D.6

	ACKN	LT <sub>I<sub>p</sub></sub> = LAST-BCK	How transmitter shall act
(a)	Yes	No	normal advance (or retransmit)
(b)	Yes	Yes	retransmit or jump
(c)	No	No	retransmit or jump
(d)	No	Yes	retransmit or jump

The transmitter shall use the jump procedure when the packet limit lifetime expires.

In state (b) the transmitter can choose between retransmission and jump. Its choice is reflected in the pkt number chosen. If jump the pkt number toggles if retransmit the pkt number is unchanged.

## D.1.5 Bearer Replacement

NOTE: It is proposed to change current subclause 10.6.4 Frequency Replacement into Bearer Replacement and to have two subclauses, general bearer replacement and as a special case of bearer replacement the Frequency replacement procedure.

## D.1.6 Extended FP capabilities

Table D.7: Extended FP capabilities

MAC message	Field within the message		Normative action/comment
<<FP capabilities>>			
	<Q <sub>H</sub> >		
NEW	<a21>		MAC suspend and resume procedure supported
NEW, changed meaning	<a41>		asymmetric connection supported
NEW	<a45>		DPRS stream support
NEW	<a46>		DPRS FREL support
Add this values to the existing table in the base standard.			

## D.2 Amendments to EN 300 175-4

### D.2.1 FU-10 frame structure

The text below shall replace the text of the indicated clause.

#### 12.11 FU10 frame structure

##### 12.11.1 General frame structure

FU10 defines three fixed length frames. The total frame length shall always be equal to the segment size of the appropriate logical channel as detailed below.

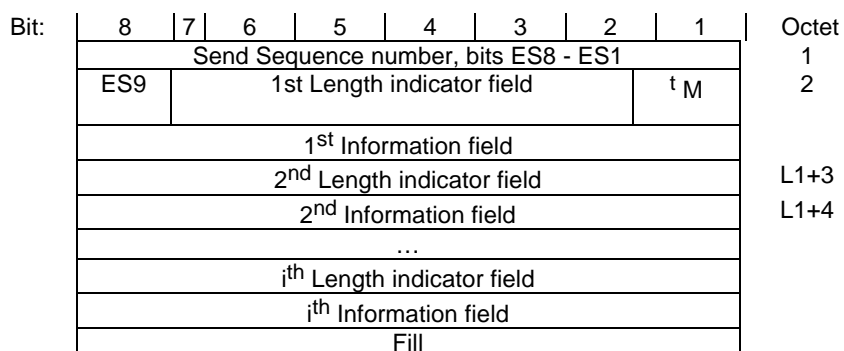

Figure D.5: Frame format type FU10a

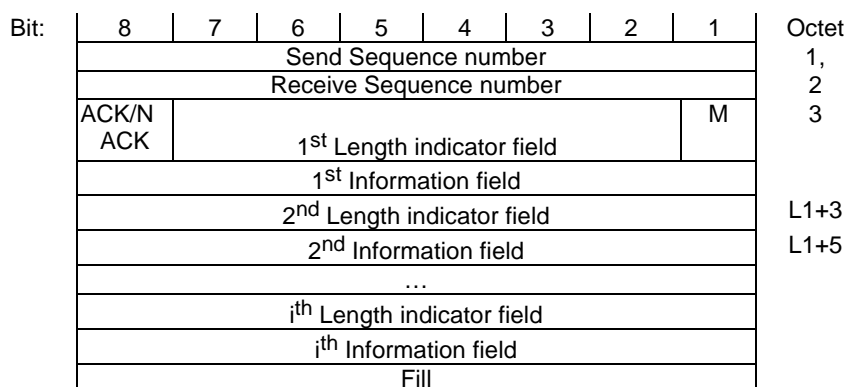

Figure D.6: Frame format type FU10b

Bit:	8	7	6	5	4	3	2	1	Octet
	RSN # 1, ES8 - ES1								1
	RSN # 2, ES8 - ES1								2
	RSN # 3, ES8 - ES1								3
	RSN # 4, ES8 - ES1								4
	RSN # 5, ES8 - ES1								5
	RSN # 6, ES8 - ES1								6
	NA1	NA2	RSN #6, ES9	RSN #5, ES9	RSN #4, ES9	RSN #3, ES9	RSN #2, ES9	RSN #1, ES9	7

**Figure D.7: Frame format type FU10c**

NOTE: For meaning of the NA1 and NA2 bits: see text in 14.3.4.2.

## D.2.2 Length indicator elements

The text below shall replace the text of the indicated clause.

### 13.3 Length indicator elements

#### 13.3.1 Length indicator field format

Bit:	8	7	6	5	4	3	2	1
	L7	L6	L5	L4	L3	L2	L1	M

**Figure D.8: Length indicator field format**

M: More data bit;

$L_I$ :  $I \in \{7..1\}$  Length of Information field (octets).

For D160 and D240 slot formats, the length indicator is 2 bytes long. The format of the additional byte is as follows.

Bit:	8	7	6	5	4	3	2	1
	L15	L14	L13	L12	L11	L10	L9	L8

**Figure D.9: Length indicator field additional byte format**

In case of D160 and D240 slot formats the following applies for the length indicator  $L_I$ :

$L_I$ :  $I \in \{15..1\}$  Length of Information field for D160 and D240 slot format (octets).

For frame type FU10a and FU10b the first length indicator shall be as follows, instead of the description in figure D.8.

Bit:	8	7	6	5	4	3	2	1
	ES9	L6	L5	L4	L3	L2	L1	M

**Figure D.10: FU10a First length indicator format**

Bit:	8	7	6	5	4	3	2	1
	ACK/ NACK	L6	L5	L4	L3	L2	L1	M

**Figure D.11: FU10b First length indicator format**

In case of frame type FU10a and FU10b the following applies for the length indicator  $L_I$ :

$L_I$ :  $I \in \{6..1\}$  Length of Information field for FU10a and FU10b frame type.

In case of frame type FU10a the following applies:

The Send sequence number is extended with bitES9 of the 1<sup>st</sup> length indicator field. In all other length indicator fields this bit shall be ignored.

### 13.3.2 Length indicator field parameters

Extended more data bit M: the extended more data bit, M, is used to indicate segmentation of messages into FUx frames.

M = "1" indicates that the information field only contains part of a message - there is more to follow.

M = "0" indicates one of two things:

- a) that the information field contains a complete message, provided that the M bit of the previous frame was also set to "0";
- b) that the information field contains the last segment of a message, provided that the M bit of the previous frame was set to "1".

When the M bit is set to "1", the information field should contain the maximum number of octets.

NOTE 1: This rule only recommends that each frame contains the maximum amount of information. However, the  $L_1$  field always defines the actual length.

When using frame type FU10a or FU10b a M bit set to "0" means additionally, that the next M bit within this PDU has to be examined, if more data of a further SDU follows in this PDU.

To indicate that there is no data of a further SDU following within the current PDU, both the M bit and  $L_1$  shall be set to "0".

Length parameter  $L_1$ : the length parameter  $L_1$  consists of 7 bits for all slot formats except for D160 and D240 and except the FU10 frame format. For D160 and D240 slot formats, the length parameter  $L_1$  consists of 15 bits. For FU10 the length parameter consists of 6 bits. The length parameter  $L_1$  defines the length of the information field in all frames.

Allowable values for 2 level modulated full slot formats are:

- 0 to 30 for frame types FU2, FU6a and FU10a;
- 0 to 29 for frame types FU4a and FU10b;
- 0 to 28 for frame types FU5a.

NOTE 2: Maximum value for full slot is 30 octets. 7 bits are allowed for possible double slot D80 operation - 100 octets. For D160 and D240 operation, 7 bits are not enough and hence 2 octets are required for the Length Indicator field.

$L_1$  = "0" is used for all frames that contain no higher layer information.

NOTE 3: Frames that contain no higher layer information should not be transmitted.

Remaining (unused) octets shall be filled with the standard fill octet defined in subclause 13.5.

## D.2.3 Sequence number elements

The text below shall replace the text of the indicated clause.

### 13.4 Sequence number elements

#### 13.4.1 Send sequence number format

Bit:	8	7	6	5	4	3	2	1
	I/R	ES7	ES6	ES5	ES4	ES3	ES2	ES1

**Figure D.12: Send sequence number field format**

$ES_I$  = Send Sequence Number (7-bits);  $I \in \{7..1\}$ ;

I/R = Initial/Retransmission bit.

For frame format FU10a and FU10b the following Send sequence number format shall be used:

Bit:	8	7	6	5	4	3	2	1
	ES8	ES7	ES6	ES5	ES4	ES3	ES2	ES1

**Figure D.13: Send sequence number field format for FU10**

For FU10a the ES9 bits from the length indicator shall be added to the 8 bits shown above. (subclause 13.3.1).

$ES_I$  = Send Sequence Number (9-bits);  $I \in \{9..1\}$ .

#### 13.4.2 Send sequence number parameters

At the time that an in-sequence frame is designated for transmission, the value of  $ES_I$  is set equal to the value of the send state variable SN according to the selected transmission class. Refer to subclauses 14.2 and 14.3.

The I/R bit shall define the meaning of the send sequence number contained in the same octet, using the following coding:

I/R = "1" First transmission (of this frame);

I/R = "0" Retransmission (of this frame).

#### 13.4.3 Receive sequence number format

Bit:	8	7	6	5	4	3	2	1
	A/N	ER7	ER6	ER5	ER4	ER3	ER2	ER1

**Figure D.14: Receive sequence number field format**

$ER_I$  = Receive sequence number (7-bits);  $I \in \{7..1\}$ ;

A/N = ACK/NACK bit.

For frame type FU10b the following receive sequence number format shall be used:

Bit:	8	7	6	5	4	3	2	1
	ER8	ER7	ER6	ER5	ER4	ER3	ER2	ER1

**Figure D.15: Receive sequence number field format for FU10b**

$ER_I$  = Receive sequence number (10-bits);  $I \in \{8..1\}$ ;

NOTE: The A/N = ACK/NACK bit. is contained in the length indicator field (octet 3). (subclause 13.3.1).

## D.2.4 Class 2: variable throughput, maximum delay LUx retransmission

The text below shall replace the text of the indicated clause.

### 14.2.3.3 Class 2: variable throughput, maximum delay LU<sub>x</sub> retransmission

This service is characterized by the demands of variable throughput with controlled maximum delay. Each frame is retransmitted until acknowledged, or until a timer expired. The DLC retransmission shall operate in selective retransmission protocol (SEL).

This may use the following MAC services:

I<sub>p</sub>: error-correct

I<sub>p</sub>: error-detect

All error detection uses the normal MAC error detection procedures (see EN 300 175-3 [3]).

NOTE: Care is needed to ensure that the application does not retransmit faster than the DLC retransmission; this could cause the offered throughput to decrease catastrophically.

## D.2.5 Class 2 procedures

The text below shall replace the text of the indicated clause.

### 14.3.4 Class 2 procedures

Class 2 operation uses both SNs and RNs. The RNs provide both window control to avoid possible sequencing errors, and also invoke automatic DLC retransmission. The DLC retransmission shall operate a selective retransmission protocol.

#### 14.3.4.1 Sending side procedure

The sending entity shall add SNs to all PDUs to be transmitted in frames in the order specified by that entity. A synchronization message shall be sent after data has timed out at the transmitter. The synchronization message contains no data (PDU) but it shall be treated by the sending entity as if it were a PDU.

The synchronization frame shall have the following structure:

Bit:	8	7	6	5	4	3	2	1	Octet:
	S8	S7	S6	S5	S4	S3	S2	S1	1
	S9	1	1	1	1	1	1	M	2
	Payload								3
									:
									:
									:
									:
									:
									:
									:
									:
									:
									32

Figure D.16: Synchronization message frame

Where:

- the length indicator is filled with 6 bits as the value "63" is used to indicate a synchronization frame;
- the send sequence number field contains the send sequence number of the last expired PDU;
- the M bit is set to 0;
- the content of the payload is irrelevant.

The PDUs shall be submitted to the MAC layer in the order of ascending SN, taking into account the modulus operation of the sequence numbering.

NOTE 1: sequence number 0 is higher than sequence number (modulus - 1).

NOTE 2: This rule means that retransmissions always have priority relative to first transmissions.

The sending entity shall maintain a maximum window size between the SN and the last received RN. The maximum window size shall be:

- (Modulus-1) when using GbN;
- (Modulus div 2) when using SEL.

A lower maximum value may be negotiated at call establishment (see subclause 14.2.4). A smaller operating window size may be unilaterally adopted by the sending entity at any time.

Due to the modulo operation, each SN may be re-used several times during the life of the link. The minimum interval between reuse shall meet the following requirement:

- an SN shall not be reused within L(S) TDMA frames of the most previous use of that number.

The value of L(S) shall be determined by the protocol used:

- using I<sub>p</sub>-error-correction, L(S) shall be equal to the MAC packet lifetime+1 (as defined at service establishment);
- using I<sub>p</sub>-error-detection, L(S) shall be equal to 2.

Whenever the window size limit is reached (thereby halting further transmissions) the sending side shall commence retransmission of all outstanding PDUs not already expired, starting from the oldest unacknowledged PDU. This automatic retransmission shall be stopped whenever a usable RN is received (i.e. a RN that acknowledges one or more outstanding PDUs), and normal transmission or retransmission procedures will be resumed.

Received RN with the A/N bit set to "1" or with NA bits indicating an acknowledge, shall be treated as a positive acknowledgement for all PDUs up to and including the PDU number RN. This positive acknowledgement shall cause an immediate stop to any redundant (unnecessary) retransmissions that may have been scheduled as a result of previously received negative acknowledgements.

Received RNs with the A/N bit set to "0" shall be treated as a negative acknowledgement for the single PDU number RN. Receipt of a NACK shall cause a retransmission of the indicated PDU(s) using the agreed retransmission protocol (selective or GO\_Back\_N as appropriate).

If the maximum window size is reached, no new PDU's will be inserted in the window.

As soon as a SDU is delivered from the upper layer to the DLC, a timer shall be associated with it. The SDU lifetime shall be equal to T(R) TDMA frames. Whenever a timer reaches the T(R) value, the respective SDU shall be considered expired and not (re)transmitted anymore.

The transmitting window shall not shift due to the expiry of those PDUs belonging to the expired SDU.

If a PDU contains (parts of) more than one SDU, the lifetime is associated to the lifetime of the last SDU in this PDU.

The lifetime limit should be defined at call establishment and shall not be subsequently changed. If the lifetime limit is not specified at call establishment the following value shall apply:

- T(R) = infinite TDMA frames.



NOTE 3: When a PDU is about to be discarded due to lifetime expiry then the transmitter may re-transmit this PDU in an attempt to prevent data loss.

NOTE 4: The value T(R) should normally be negotiated with the <<transit-delay>> element during call establishment (see EN 300 175-5 [5]).

During the lifetime the transmitter may retransmit the PDU. Retransmissions shall be stopped when the PDU is acknowledged.

When one or more PDUs expire, then the last expired PDU shall be replaced by the synchronization message. The synchronization message shall contain the sequence number of this PDU.

NOTE 5: Expiry of all PDUs in the transmit window will cause a re-transmit of the synchronization message only, until acknowledge. Then the transmit window can advance and take new PDUs.

Acknowledge of the synchronization message shall use a special synchronization acknowledge to indicate the correct reception of the synchronization message. When the transmitter receives this acknowledge, it knows the receiver has re-synchronized its window and the transmitter is also allowed to move the transmit window forward, accepting new PDUs for transmission.

#### 14.3.4.2 Receiving side procedure

The receiving entity shall accept data packets from the MAC layer in any order. Packets marked as type "unknown" and any packets that are indicated to contain errors shall be discarded. The remaining packets shall be assumed to contain valid PDUs, and shall be processed in their order of arrival. PDUs with sequence number outside the receive window shall be discarded. Only a synchronization message shall be accepted always, even if the sequence number is outside the receive window. Duplicate PDUs shall also be discarded.

NOTE 6: Discarded valid PDUs should preferably be acknowledged to prevent unnecessary retransmissions, by retransmitting the last acknowledge.

In-sequence PDUs are defined as a series of one or more PDUs that contain no errors and that contain SN(s) that together form a continuous series of SNs when considered together with other received but undelivered PDUs. All in-sequence PDUs shall immediately be delivered to the higher functions and acknowledged.

As soon as a synchronization message has been received, the RN shall be set to one higher than the value of the SN contained in the synchronization message and all the buffered PDUs with an SN lower than or equal to the received one should be discarded.

NOTE 7: Discarding these PDUs guarantees the maximum lifetime. Synchronization indicates their lifetime has expired.

The re-synchronization shall be sent to higher functions to indicate a discontinuity in PDU numbering.

NOTE 8: Actual numbering might be continuous due to the modulo numbering scheme.

The synchronization message shall always be acknowledged using a special synchronization acknowledge, in order to indicate that the transmitter can advance its window. The synchronization acknowledge can have two formats, depending on the connection type:

- symmetric connection uses the same format as the synchronization message for the synchronization acknowledge: the Length Indicator has value 63 and the sequence number of the synchronization message is returned;
- asymmetric connection uses the G<sub>F</sub>-channel ACK/NACK message with a special coding for NA1 and NA2 bits = 0,0 as shown below.

Bit:	8	7	6	5	4	3	2	1	Octet
	RSN # 1, ES8 - ES1								1
	RSN # 2, ES8 - ES1								2
	RSN # 3, ES8 - ES1								3
	RSN # 4, ES8 - ES1								4
	RSN # 5, ES8 - ES1								5
	RSN # 6, ES8 - ES1								6
	NA1	NA2	RSN #6, ES9	RSN #5, ES9	RSN #4, ES9	RSN #3, ES9	RSN #2, ES9	RSN #1, ES9	7

**Figure D.17: Frame FU10c for slot type D32, 9 Bit sequence numbering**

The interpretation of the RSNs as either ACKs or NACKs is indicated by bits NA1 and NA2.

Bit	NA1	NA2	Meaning
0	0	0	this frame contains an Ack of a synchronization message in RSN#1, no NACKs
0	1	0	this frame contains only one ACK message in RSN#1, no NACKs
1	0	0	this frame contains one ACK message in RSN#1 plus five NACK messages in RSN#2-RSN#6
1	1	1	this frame contains six NACK messages

Out-of-sequence PDUs are defined as all other PDUs (i.e. a sequence of one or more PDUs that do not form a continuous series of SNs or contain some errors).

If after buffering for L(R) TDMA frames, out-of-sequence remains out-of-sequence, the receiving entity should return a composed NACK message.

After that, as long as the out-of-sequence PDUs remain out-of-sequence, they shall continue to be buffered and at most one composed NACK message may be sent in any period of L(R) TDMA frames.

Out-of-sequence PDUs may become in-sequence PDUs due to the arrival of one or more of the missing PDUs. In this event, the PDUs shall immediately be delivered to the higher functions.

For the GBN protocol a NACK shall carry a single value of RN, set equal to the lowest numbered missing PDU. For the SEL protocol, multiple RN values shall be returned; one for each missing PDU.

NOTE 9: Out of sequence PDUs may be discarded during this buffer period, in order to limit buffer sizes.

The value of L(R), shall be determined by the service used:

- when using the  $I_p$ -error-correction protocol:  
L(R)=( MAC packet lifetime+1);
- when using the  $I_p$ -error-detection protocol:  
L(R)=1 TDMA frames;

Whenever PDUs are delivered to the higher functions, the RN for all positive acknowledgements shall be set equal to the highest delivered SN + 1.

## D.2.6 LU10 Enhanced Frame RELay (EFREL) Service

### 11.12 LU10 Enhanced Frame RELay (EFREL) Service

#### 11.12.1 General

The LU10 is a general data transmission service for medium data rates, high error correction performance and low complexity. LU10 provides a peer-to-peer connection protocol for an acknowledged exchange of user data within the DLC\_U-Layer.

For LU10 the use of ARQ-type SEL is recommended. Go\_Back\_N is also allowed.

LU10 shall provide the following functions:

- peer-to-peer transmission of user data (SDUs);
- segmentation of SDUs into PDUs;
- management of the V(S), V(R) state variables(s) and handling of N(s) and N(R) according to the transmission class used;
- multiple SDU transfer, which means that more than one SDU (or only a part of it) can be inserted in one PDU.

LU10 shall not provide the following functions:

- add neither additional header nor checksum to SDUs.

### 11.12.2 Segmentation and transmission class

The SDU shall be segmented into fixed length segments, where the segment length shall depend on the PDU structure chosen. The alternative PDU structures shall correspond to one of the internal frame types defined in clause 12, where the type depends on the chosen class of service. LU10 may use any one of the following combinations of transmission class and PDU structure.

**Table D.8: Transmission classes for LU10 operation**

Transmission class	PDU structure
Class 2/bi-directional or unidirectional	FU10
Class 3/bi-directional or unidirectional	FU10
NOTE 1: Other PDU structures/transmission classes are for further study.	
NOTE 2: Each Instance of LU10 only uses a single class of service and a single frame type for all data transmission, and this is defined at service establishment.	

In all cases the original SDU boundaries shall be preserved (i.e. service integrity shall be maintained) by use of a length indicator and extended More bit as defined in subclause 13.3.

### 11.12.3 Data transmission

#### 11.12.3.1 Send side procedures

At the transmitting side a complete SDU shall be received in a DL\_U\_DATA-req primitive. The SDU shall be passed to the segmenting function and segmented into an integral number of segments. The last segment shall be filled with fill octets if necessary. The information content of each PDU shall be marked using the length indicator as described in subclause 13.3, and sequence numbers shall be added using the rules defined in subclauses 13.4.

The resulting PDUs shall be transmitted in ascending order of sequence number (i.e. the lowest numbered segment shall be transmitted first), using the procedures defined in subclause 14.3 for the agreed class of operation.

It is possible to insert several SDUs (or parts of them) in one PDU. For detailed information see 13.3.2.

Several PDUs may be submitted at once to the MAC layer in a single MAC\_CO\_DATA-req primitive in response to each MAC\_CO\_DTR-ind primitive. The number of PDUs shall be less than or equal to the maximum number requested in the MAC\_CO\_DTR-ind primitive.

#### 11.12.3.2 Receive side procedure

Several PDUs may be received from the MAC layer in a single MAC\_CO\_DATA-ind primitive. The receive side shall re-order the PDUs using the send sequence numbers as defined in subclauses 14.2 and 14.3 according to the agreed class of operation. The receive side shall then search for SDU boundaries using the extended more bit as defined in subclause 13.3.

A complete SDU shall be assumed to exist, and shall be passed to the IWU using a DL\_U\_DATA-ind primitive when the following conditions are satisfied:

- 1) two successive boundaries have been identified using the extended More bit (i.e. there are no intermediate boundaries);
- 2) PDUs have been successfully received for all of the sequence numbers that lie between those boundaries.

## D.3 Amendments to EN 300175-5

### D.3.1 Changes to subclause 7.7.43

Modify the contents of the <<WINDOW SIZE>> information element to: repair a number of editorial errors and to extend the possible range of Window size values.

#### 7.7.43 WINDOW SIZE

The purpose of the <<DLC-U-plane-parameters>> element is to indicate (and optionally to negotiate) the window size to be used for frame transmission. replace current content with the following:

Bit:	8	7	6	5	4	3	2	1	Octet:
	0	<< WINDOW SIZE >>							1
	Length of Contents (L)								2
	0	Window size value (forward)							3
	0/1 ext	Window size value continue							3a
	0/1 ext	Maximum PDU length (forward)							3b
	1	SDU LAPU timer (forward)							3c
	0	Window size value (backward)							4
	0/1 ext	Window size value (continue)							4a
	0/1 ext	Maximum PDU length (backward)							4b
	1	SDU LAPU timer (backward)							4c

Figure D.18: WINDOW SIZE information element

If octet group 4 is omitted, the backward values shall be understood to be equal to the forward values.

**Window size value (Forward and backward) octet 3 and 3a (and 4 and 4a):** the <<WINDOW-SIZE>> shall be coded with the natural binary value, and the result placed starting in octet 3a (4a) with the least significant bit in position 1 of octet 3a (4a).

The value "0" shall be used to indicate "not applicable" in the event that no window size is defined for the forward direction.

**Maximum (Forward and backward) PDU length (octets 3b, 4b)** is coded as natural binary value and the value of this field multiplied by 60 bytes shall give the maximum size of the PDU used by a profile.

**SDU LAPU timer (Forward and backward) (octet 3d, 4d)** value is coded as natural binary value.

## D.3.2 Changes to subclause 7.7.41

Modify the description of some fields in the <<Terminal Capability>> information element to:

### Profile Indicator\_1 Coding (Octet 4):

Bits	7 6 5 4 3 2 1	Meaning
x x x x x 1		CAP supported
x x x x x 1 x		GAP supported
x x x x 1 x x		DECT/GSM interworking profile supported
x x x 1 x x x		ISDN supported
x x 1 x x x x		Data Services Profile E, class 2
x 1 x x x x x		<u>DPRS Stream support</u> <del>Data Services Profile A/B, class 2</del>
1 x x x x x x		<u>DPRS asymmetric bearers support</u> <del>Multi-bearers supported for the Data Services Profiles</del>

### Profile Indicator\_2 Coding (Octet 4a):

Bits	7 6 5 4 3 2 1	Meaning
x x x x x 1		<u>DPRS FREL support</u> <del>Data Services Profile C, class 2</del>
x x x x x 1 x		Data Services Profile D, class 2
x x x x 1 x x		Data Services Profile F, class 2
x x x 1 x x x		DECT/GSM interworking - GSM Bearer service
x x 1 x x x x		DECT/GSM interworking - GSM SMS service
x 1 x x x x x		DECT/GSM interworking - GSM Facsimile service
1 x x x x x x		CTM FP 1 32 kbps

### Profile/Application Indicator\_3 Coding (Octet 4b):

Profile/Application indicator\_3 Coding (Octet 4B):

Bits	7 6 5 4 3 2 1	Meaning
x x x x x 1		DECT/GSM dual mode terminal
x x x x x 1 x		WRS
x x x x 1 x x		CTM FP2 SMS
x x x 1 x x x		<u>DMAP support</u> <del>reserved</del>
x x 1 x x x x		MRAP support
x 1 x x x x x		reserved
1 x x x x x x		reserved

## D.3.3 Changes to subclause 7.7.21

Modify the description of some fields in the <<IWU attributes>> information element to:

### Profile (octet 3):

Bits	5 4 3 2 1	Meaning
0 0 0 0 0		<u>DPRS FREL A/B data profile</u>
0 0 0 0 1		<u>DPRS Stream C data profile</u>
0 0 0 1 0		D data profile
0 0 0 1 1		E data profile
0 0 1 0 0		F data profile
0 1 0 0 0		GSM circuit mode NT
0 1 0 0 1		GSM circuit mode T
0 1 0 1 0		GSM packet mode
0 1 0 1 1		GSM messaging
0 1 1 0 0		GSM Facsimile service group 3
0 1 1 0 1		CTM FP1 32 kbps
0 1 1 1 0		<u>DMAP</u>
0 1 1 1 1		<u>MRAP</u>
		All other values reserved.

## D.3.4 Changes to subclause 7.7.5

Modify the description of some fields in the <<Call attributes>> information element to:

### NWK layer attributes (octet 3):

Bits	5 4 3 2 1	Meaning
	0 0 0 0 0	Undefined
	0 0 0 0 1	Basic speech
	0 0 0 1 0	DPRS
	0 1 0 0 0	DECT GSM IWP profile phase 2
All other values reserved.		

## D.3.5 Changes to subclause A.1

Add to the contents description for the following timer:

<CC_service>:	Service Change timer;
Value:	20 sec
Start:	{CC-SERVICE-CHANGE} message is sent;
Stop:	An indication for link release from the DLC is received; A {CC-SERVICE-ACCEPT} or a {CC-SERVICE-REJECT} message is received; {CC-RELEASE}, {CC-RELEASE-COM} messages are sent or received.

## D.3.6 Changes to subclause 6.3.6.1

Add <<Setup capability>> to the list of allowed information elements in the {ACCESS-RIGHTS-ACCEPT} message.

### 6.3.6.1{ACCESS-RIGHTS-ACCEPT}

This message is sent by the FT to the PT to transfer the access rights parameters to the PT.

Table D.9

Message Type		Format		Directions
{ACCESS-RIGHTS-ACCEPT}		S		F=>P
Information Element	Subclause	F to P message	P to F message	Length octets
Protocol Discriminator	7.2	M	-	½
Transaction Identifier	7.3	M	-	½
Message Type	7.4	M	-	1
Portable identity	7.7.30	M	-	7-20
Repeat Indicator 1	7.6.3	O	-	1
Fixed identity(PARK) 1	7.7.18	M	-	5-20
Location area	7.7.25	O	-	3-*
AUTH-TYPE	7.7.4	O	-	5-6
Cipher info	7.7.10	O	-	4-5
ZAP field	7.7.44	O	-	3
Service class	7.7.39	O	-	3-*
Setup capability	7.7.40	O	-	3-*
Model identifier	7.7.46	O	-	5-20
IWU-TO-IWU	7.7.23	O	-	4-*
Escape to proprietary	7.7.45	O	-	2-*
M	= Mandatory;			
N	= Not allowed;			
O	= Optional;			
-	= not applicable.			

NOTE: More than one PARK can be transmitted by using the <<REPEAT-INDICATOR>> information elements. In this case the coding for "non-prioritized list" should be used. Not more than 5 PARKs should be included.

## D.3.7 Changes to subclause 6.3.6.17

Add <<Setup capability>> to the list of allowed information elements in the {LOCATE-ACCEPT} message.

### 6.3.6.17 {LOCATE-ACCEPT}

This message is sent by the FT to the PT to indicate that location updating or attach has been completed.

**Table D.10**

Message Type		Format		Directions
{LOCATE-ACCEPT}		S		F=>P
Information Element	Subclause	F to P message	P to F message	Length octets
Protocol Discriminator	7.2	M	-	½
Transaction Identifier	7.3	M	-	½
Message Type	7.4	M	-	1
Portable identity 1	7.7.30	M	-	2-20
Location area	7.7.25	M	-	3-*
Use TPUI	7.6.2	O	-	1
NWK assigned identity	7.7.28	O	-	5-20
Ext h/o indicator	7.7.51	O	-	3
Setup capability	7.7.40	O	-	3-*
Duration	7.7.13	O	-	4
IWU-TO-IWU	7.7.23	O	-	4-*
Model identifier	7.7.46	O	-	5-20
Escape to proprietary	7.7.45	O	-	2-*
M	= Mandatory.			
O	= Optional.			

NOTE: This element may contain zero length contents if a new TPUI is not assigned.

## D.3.8 Changes to subclause 6.3.6.22

Add <<Setup capability>> to the list of allowed information elements in the {MM-INFO-REQUEST} message

### 6.3.6.23 {MM-INFO-SUGGEST}

This message is sent by the FT to provide information to the PT or to suggest an action to the PT, e.g. to perform location updating or access rights modification or an external handover.

Table D.11

Message Type		Format		Directions
{MM-INFO-SUGGEST}		S		F=>P
Information Element	Subclause	F to P message	P to F message	Length octets
Protocol Discriminator	7.2	M	-	1/2
Transaction Identifier	7.3	M	-	1/2
Message Type	7.4	M	-	1
Info type	7.7.20	M	-	3-*
Call Identity	7.7.6	O	-	3-*
Fixed identity	7.7.18	O	-	5-20
Location area	7.7.25	O	-	3-*
NWK assigned identity	7.7.28	O	-	5-20
Network parameter	7.7.29	O	-	3-*
Ext h/o indicator	7.7.51	O	-	3
KEY	7.7.24	O	-	4-*
Setup capability	7.7.40	O	-	3-*
IWU-TO-IWU	7.7.23	O	-	4-*
Escape to proprietary	7.7.45	O	-	2-*
M	= Mandatory.			
O	= Optional.			
-	= not applicable.			

## D.3.9 Changes to subclause 7.7.40

Change to Setup capability information element to allow additional information.

### 7.7.40 Setup capability

The purpose of the <<SETUP-CAPABILITY>> element is to convey some aspects of the PP call setup capabilities to the FP during location registration.

Bit:	8	7	6	5	4	3	2	1	Octet:
	0	<< SETUP-CAPABILITY >>							1
	Length of Contents (L)								2
	0/1	Protocol Discriminator			Setup		Page		3
	1	0	0	0	0	0	0	0	3a
	Spare (see note 1)								

Figure D.19: SETUP-CAPABILITY information element

### Page capability coding (octet 3):

Bits	2 1	Meaning
	0 1	Normal paging
	1 0	Fast paging
	All other values reserved.	



**Setup capability coding (octet 3):**

Bits	4 3	Meaning
	0 1	Normal setup
	1 0	Fast setup
		All other values reserved.

**Protocol Discriminator (octet 3):**

Bits	7 6 5	Meaning
	0 0 0	Shall not be used (see note 2)
	0 0 1	DPRS (see note 3)
		All other values reserved.

NOTE 1: Explicit provision for extension of this element is provided. Implementors should use the 0/1 ext flag (bit 8) to detect the use of additional octets in future versions. Exact coding may be defined in relevant profiles.

NOTE 2: For backwards compatibility with terminals already using this information element complying with versions of the standard before ed4.

NOTE 3: The exact coding of the octets to follow is to be defined in the DPRS profile.

## D.3.10 Changes to subclause 6.3

Change the possible length indication for <<Setup capability>> in all messages that may include it to 3-\*

## D.3.11 Changes to subclause 8.3

Modify text and Add codings to CLMS-FIXED message.

### 8.3.1 General message structure

Each {CLMS-FIXED} message shall contain 1 or more message sections, where each section shall contain 36 bits of information in a 5 octet frame. {CLMS-FIXED} messages can ~~only~~ carry information equivalent to that contained in the <<ALPHANUMERIC>> information element (see subclause 7.7.3) or other specific information. {CLMS-FIXED} messages shall use the extended format.

The first section of each message shall contain addressing and control information. The remaining sections shall contain any data. The contents of any given section shall be indicated by the A bit.

Each message shall only comprise complete sections, up to a maximum of 6 sections (i.e. one address section followed by up to 5 data sections). All of the sections for a complete message shall be delivered in a single primitive, and should be received in a single primitive. Refer to subclause 12.3.1.

NOTE: The received message may be incomplete. Missing sections may not be detected by the lower layers before delivery. Missing sections may be detected by examining the length indicator element and/or the data segment numbers.

The possible data structures are defined by the protocol discriminator field, ~~this shall use the same coding as octet 3 of the <<ALPHANUMERIC>> information element. This allows for either 8 bit characters, 4 bit characters or application specific codings.~~

/...

### CLMS header coding (octet 1):

The header coding is different for address sections and data sections. The address section allows three ~~two~~ types of message to be defined, a DECT standard message, or, a general alphanumeric message, or, a general bit stream message. The basic structure of these first two messages is the same, but DECT standard messages provide standard codings for the message contents.

**CLMS header coding for address section:**

Bits	3 2 1	Message type	octet 4	octet 5
	0 0 1	One section:	Standard	Data
	0 1 0	Multi-section:	Standard	Length indicator
	0 1 1	One section:	Bit stream	Data
	1 0 0	Multi-section:	Bit stream	Length indicator
	1 0 1	One section:	Alphanumeric	Data
	1 1 0	Multi-section:	Alphanumeric	Length indicator
		All other values reserved.		

**Protocol discriminator (octet 4 of address section):**

/...

Coding as for octet 3 of &lt;&lt;Bit stream&gt;&gt;

Bit:	8	7	6	5	4	3	2	1	Octet:
	0	Second Discriminator							4

**Figure D.20: Format of Protocol Discriminator (PD)**

Bits	7 6 5 4 3 2 1	Meaning
	0 0 0 0 0 0 1	DECT Information elements coding
		All other values reserved.

When this value is used the data field shall contain only DECT information elements as coded in the present document. Multiple information elements may be included.

## D.3.12 Changes to subclause 7.7.20

Add coding to the <<Info type>> information element.

**7.7.20 Info type****Parameter type coding (octet 3):**

Bits	7 6 5 4 3 2 1	Meaning
	0 0 0 0 0 0 0	locate suggest
	0 0 0 0 0 0 1	access rights modify suggest
	0 0 0 0 1 0 0	authentication of PP failure
	0 0 0 0 1 1 0	<u>Dynamic parameters allocation</u>
	0 0 0 1 0 0 0	external handover parameters (see note)
	0 0 0 1 0 0 1	location area
	.....	All other values reserved.

## D.3.13 Changes to subclause 8.2.1

Modify LCE header coding allocation

### 8.2.1 Short format message

/...

#### LCE header coding

The LCE header coding shall indicate the U-plane service (MAC service type) required. In addition it may indicate whether the message is used to start ringing at the portable part, see subclause 14.4:

<b>Bits</b>	<b>3 2 1</b>	<b>U-plane service (MAC service type)</b>
	0 0 0	None
	0 0 1	Unknown (MAC service type) & Ringing
	0 1 0	<u>Escape</u> <del>Reserved</del>
	0 1 1	Unknown

.....

## D.3.14 Changes to subclause 8.2.2

Add to the clause.

### 8.2.2 Long format message

/...

When LCE Header = 010 (escape) different coding is provided as follows:

Bit:	8	7	6	5	4	3	2	1	Octet:
	X	X	X	X	W=1	LCE Header = <b>010</b> <b>(escape)</b>			<b>1</b>
	<b>Attributes</b> <b>Discriminator</b>				TPUI Address				<b>2</b>
	TPUI Address (cont)								<b>3</b>
	TPUI Address (cont)								<b>4</b>
	<b>Target bearers</b> <b>spare (0000)</b>				<b>MAC-pkt life</b> <b>Connection Identity</b>				<b>5</b>

- Discriminator

<b>Bits</b>	<b>8 7 6 5</b>	<b>Meaning</b>
	0 0 0 0	User specific
	0 0 0 1	Resume paging
	All other values reserved.	

- Connection identity

<b>Bits</b>	<b>4 3 2 1</b>	<b>Meaning</b>
	0 0 0 0	Not applicable
	1 n n n	LCE=n n n

## D.3.15 Add subclause 14.5

### 14.5 Resume Paging

This procedure is closely related to MAC resume procedure as defined in EN 300 175-3 [3].

If MAC layer paging fails (e.g. PP has moved to another cluster) the FT LLME shall request the FT-NWK LCE for initiating a LCE resumption providing the ECN of the related link.

As result the LCE shall construct a Long Page message as defined in, subclause 8.2.2 using the LCE header code "escape" and the discriminator code "Resume paging". The Connection identity for the connection to be resumed shall be provided.

The LCE shall issue the {LCE-REQUEST-PAGE} message using either a DL\_BROADCAST-req primitive or a DL\_EXPEDITED-req primitive via the B-SAP. It shall then mark the link as in the "RESUMPTION PENDING" state, and shall start timer <LCE.03>.

If timer <LCE.03> expires before the wanted link is established, the LCE should resubmit the {LCE-REQUEST-PAGE} message. Resubmitted messages shall only be issued at a lower priority than other outstanding B-FORMAT messages. A message may be resubmitted a maximum of N300 times, before it is discarded. (N300 is an application specific value. Recommended value for voice applications is 3).

If the {LCE-REQUEST-PAGE} message is successfully received by the intended PT, it shall check whether there is a link in ACTIVE state which can be identified by the received in the paging message Connection identity. If such link exists the PT shall construct a LCE-PAGE-RESPONSE message following the rules as described in subclause 14.2.3 and shall send it in a DL-DATA-req primitive over the existing link.

**NOTE:** The arrival of this message at PT MAC layer will consequently trigger a PT initiated connection resumption at MAC.

On receipt of the LCE-PAGE-RESPONSE (over the resumed connection) the FT-LCE shall check the identity contained in this response against a list of outstanding {LCE-REQUEST-PAGE} messages, and if the identity matches the identity associated with this link FT-LCE shall mark the link as "LINK ESTABLISHED"; it shall stop timer <LCE.03> and shall continue with normal operation (i.e. with the action that was the reason for the required resumption).

## D.3.16 Add Distributed Communication changes to Base standard

Annex E introduces the concept of the Distributed communications in DECT. Number of changes to the DECT CI, EN 300 175, standard are required.

## D.3.17 U-plane frame type

EN 300 175-5 [5], 7.7.5.

**Bits**    **4 3 2 1**    **Meaning**

....

1 0 1 0 FU10a/c

1 0 1 1 FU10b

All other values reserved.

---

# Annex E (normative): Distributed Communication Specification Protocol Requirements

## E.1 Definitions and Abbreviations

### E.1.1 Definitions

**Active terminal/member:** A member of a DCDL-net that is powered-up, has locked to the MASTER and has announced itself as being present to the MASTER.

**DECT Distributed communications:** DECT Distributed communication is regarded as a communication capability of a DECT Local Network that allows a number of DECT terminals to co-exists and directly communicate with each other, such networks shall be referred hereafter as Distributed Communications DECT Local Network (DCDL-net).

**DECT Local Network (DL-net):** A DL-net is a local network comprising number of DECT terminals capable of inter-communicating which may but need not be connected to an external network.

**Hybrid Part (HyP):** A HyP is a DECT terminal that provides FT as well as PT capabilities:

- it can receive on any slot from 0 to 23;
- it can transmit on any slot from 0 to 23);
- it may transmit at least both a connectionless or a dummy bearer following the EN 300 175-3 [3] specification [1];
- it can listen to any of a connectionless or a dummy bearer transmitted by another HyP;
- it is capable of synchronizing to any of a connectionless or dummy bearer transmitted by another HyP: including synchronization to the transmitter PSCN, frame and multiframe numbers, etc.

whether it is playing the role of a FT or a PT depends on the role the terminal has in the link establishment procedure as defined in the present document.

**MASTER:** A specially dedicated terminal determining the DCDL-net synchronization and providing means of intra DCDL-net control and exchange of information. By definition a MASTER is always an Active terminal.

### E.1.2 Abbreviations

CSDb	Common System Database
DCDL-net	Distributed Communication DECT Local Network
DL-net	DECT Local Network
HyP	Hybrid Part
IdN	Identity Number

---

## E.2 General Requirements

### E.2.1 DCDL-net

A DL-net that supports Distributed communications (DCDL-net) shall:

- Have allocated a MASTER terminal to determine the intra-network synchronization and provide common for the DCDL-net information and control. If there is a terminal that is intended for constant operation (e.g. the terminal that provides voice services to an external network and is not intended to be frequently powered-down) this should be allocated as MASTER.
- Maintain for the whole time of its existence a DCDL-net System Control Bearer transmitted by the MASTER; if the MASTER is to switch-off or leave it should assign another active member as the new MASTER; the System Control Bearer should be a connectionless bearer and shall continuously provide information about the currently active members; all active DCDL-net members shall synchronize to the System Control Bearer, i.e. to the MASTER and shall continuously listen to it and retrieve the necessary information to maintain its communication within the DCDL-net.
- Posses (meaning every member of the DCDL-net shall independently possess) a Common Subscription Database (CSDb) including: common to all members AC, DCK, PLI and LAL (provision of every single value depends on the support of a particular feature); List with all members distinguished by their identification number (IdN); Information for all member including RFPI, PARK, IPUI and TPUI, terminal capabilities, etc.
- Provide means of control of the usage of the resource throughout the DCDL-net by advising reduction of the number of used bearers (valid for multi-bearer connections).

### E.2.2 Subscription

For establishment of the necessary values in the CSDb the following rules shall apply:

- a basic ARI should be assigned to particular DCDL-net at the DCDL-net initialization; this should be the ARI of the terminal assigned to be the DCDL-net MASTER at this time;
- to become a member of a DCDL-net a terminal shall subscribe to the MASTER;
- the Obtain access rights procedure shall be used to provide the PARK, PLI and IPUI; RFPI, as well as, the IdN and the TPUIs may be derived from this information;
- the Location registration procedure shall be used to provide LAL, it may be used to assign the TPUI but it can be as well automatically extracted from the IPUI instead; if TPUI is assigned during Location Registration this shall overwrite any derived TPUI;
- if provision of Encryption is supported after, subscription is accomplished, both terminals shall establish a DCK, shall cipher the link and all common for the DCDL-net keys shall be after that provided by the master to the applicant over this ciphered link - Parameter Retrieval procedure shall be used; Parameter retrieval procedure may be used for assignment of a RFPI as well in this case the assigned value shall overwrite any derived value;
- parameter retrieval procedure shall be used for provision to the applicant of information for all DCDL-net members. If encryption is provided this procedure shall be performed over an encrypted link;
- the DCDL-net's CSDb may be re-established on user request; the MASTER shall perform modification of user parameters procedure to all members; this action should be performed with care as not all members may be active at this moment and the change may make them implicitly excluded from the DCDL-net.

## E.2.3 Communication

A Terminal that wants to participate in a DL-net that supports distributed communication shall behaves as follow:

- only members of a DCDL-net can communicate within the DCDL-net;
- to become a member, a terminal (behaving as a PT ) shall request access rights from the MASTER of the DCDL-net; during the assignment of the membership access rights the applicant shall be allocated all necessary subscription data; its own data shall become part of the CSDB; shall obtain information for all members of the DCDL-net (independent of whether they are currently active or not);
- if a terminal is a member of a DCDL-net when it is powered-up, or switched to search for a DCDL-net MASTER it shall synchronize to the current MASTER (frame and multiframe numbers, PSCN, etc.) and shall constantly from this point of time on update its information as which member is currently active and may be accessed;
- shall announce itself to the MASTER as being active and thereby accessible;
- shall start listening for Paging, and, may start listening to all slots for a direct link establishment;
- if a terminal recognizes a specific Paging message that contains its TPUI and the Id of another terminal, it shall initiate direct link establishment to that terminal behaving as a PT in an Indirect FT initiated link establishment procedure as specified in EN 300 175-5 [5], subclause 14.2.2;
- if the User of a terminal wants to initiate a call and the desired terminal is currently active the User's terminal shall attempt a direct link establishment if this fails it shall request the MASTER to transmit a Paging to the desired terminal; if the desired terminal is not currently active the user shall not initiate this procedure.

It should be preferable that every active HyP terminal constantly listen to all frames thereby direct link establishment towards this terminal shall always succeed. However to allow some terminal to be part of the DCDL-net which due to power consumption would favour low duty cycle mode a special paging procedure need to be applied when such terminals need to be accessed being in low duty cycle mode.

NOTE: See clause E.5 for graphic representation of some of the communications scenarios.

---

## E.3 Procedure description

### E.3.1 HyP Identities

A HyP shall be assigned by the manufacturer a RFPI and an IPEI which should represent the two sides of the HyP.

The IPUI-N (equal to IPEI) shall be used by the HyP to request membership access rights from the DCDL-net MASTER; the RFPI may be used by the HyP for the DCDL-net ARI if a new DCDL-net is to be established and this HyP is been allocated by the user to be the MASTER, see subclause E.3.10.2.

### E.3.2 Membership Access Rights Allocation

For the Membership Access Rights Allocation procedure the normal DECT Obtain access Rights procedure shall be used.

The applicant shall provide its capabilities description indicated in a <<Terminal capability>>, a <<Set-up capability>> and an <<IWU-TO-IWU>> information elements included into the {ACCESS-RIGHTS-REQUEST} message.

**Table E.1: Values for capability description used within the {ACCESS-RIGHTS-REQUEST} message**

<<Set-up capability>>			As defined in EN 300 175-5 [5] or an applicable profile
<<Terminal capability>>			As defined in EN 300 175-5 [5] or an applicable profile
<<IWU-TO-IWU>>			
	<S/R>	1	Transmission of message
	<Protocol discriminator>	100011	Terminal Data
	<Discriminator Type>	0001	HyP Information
	<Command/Action>	0001	capabilities
	<Length of Contents>>	All	
	<Terminal type>	Any relevant	See subclause E.4.2
	<Extended capabilities>	Any	Any relevant, see subclause E.4.2

With the {ACCESS-RIGHTS-ACCEPT} message the Applicant shall be assigned a DCDL-net related PARK, IPUI and PLI according to the values allocated for this DCDL-net. All other DCDL-net terminal specific values shall be extracted from these values. For the applicable rules see subclause E.3.10 below.

Following immediately the Obtain access rights procedure a Location registration shall be performed and the terminal shall be assigned a LAL. This procedure shall indicate to the MASTER that the new member is accessible (i.e. the procedure shall be used with the meaning of an ATTACH procedure).

The procedure may be used to assign TPUI as well. If so used the TPUI shall be assigned according to the values allocated for this DCDL-net, see subclause E.3.10 below.

If DCK (Encryption) is supported, a Store DCK procedure shall take place establishing a temporary (non DCDL-net) DCK. If this key was established for the first time in the DCDL-net life (i.e. the MASTER does not have a record for such key being ever established) this key should be used as a Static CK (SCK) for this DCDL-net for further ciphering procedures. Instead the MASTER may choose to derive a SCK based on some proprietary secure enough algorithm.

As soon as a SCK is available the MASTER shall provide it to the applicant always over a ciphered link (for encrypting this link the temporary DCK shall be used). The key shall be delivered to the applicant using the Parameter retrieval procedure described in E.3.4.

The DCDL-net system SCK may be recalculated on user request in order to provide sufficient system security - such procedure shall be MASTER originated.

### E.3.3 Re-initialization of membership access rights

The DCDL-net membership access rights and hence the CSDB may be re-initialized at any time on user request or predefined periodic update procedure.

The MASTER should advise every member to initiate a new Membership Access Rights procedure during which the allocated DCDL-net related values can be assigned new. The FT initiated On air modification of user parameters procedure shall be used as defined in EN 300 824 [9].

### E.3.4 Members Data Transfer

When membership access rights have been allocated to an applicant the MASTER shall provide the new member with information for the other members and their capabilities. The Parameter Retrieval procedure shall be used as described in EN 300 175-5 [5].

If Encryption is provided the Members data transfer procedures shall take place over a ciphered link.



The information related to every member shall include:

- the IdN of the member - all DCDL-net subscription related data for particular member may be derived from its IdN, see subclause E.3.10 below;
- the Member Capability as provided in the {ACCESS-RIGHTS-REQUEST} message during the membership subscription including the <<Terminal capability>>, the <<Set-up>> capability and specific device information as provided in the <<iwu-to-iwu>>.

**Table E.2: Values used within the {MM-INFO-SUGGEST} message**

Information element	Field within the information element	Standard values within the field/IE	Normative action/comment	
<<Info-type>>	<Length of Contents >	1		
	<ext>	1		
	<Parameter type>	0100101	Distributed communication download	
<<Repeat indicator>>			Optional to use from the MASTER to provide information for number of members in one message. Mandatory to understand from the applicant/member.	
<<IWU-TO-IWU>>	<S/R>	1	Transmission of message	
	<Protocol discriminator>	100011	Terminal Data	
	<Discriminator Type>	0001	HyP Information	
	<Command/Action>	0001	capabilities as provided by the <<iwu-to-iwu>>	
	<Length of Contents>>	All	Determines whether the <Terminal data> field is included or not	
	<Terminal type>	Any	Any relevant, see subclause E.4.2	
	<Extended capabilities>	Any	Any relevant, see subclause E.4.2	
	<Terminal Id>	All	IdN-Mean to distinguish different terminals	
	<Terminal data>			
			<<Terminal Capability >>	The complete information element as received during subscription
			<<Set-up capability>>	The complete information element as received during subscription

This procedure may be used to provide as well RFPI or/and TPUIs by including the corresponding information elements <<Fixed Id>> or/and <<Portable Id>> as defined in EN 300 175-5 [5], into the <Terminal data> field. The values assigned shall be in accordance with the rules provided in subclause E.3.10 and if assigned shall overwrite any derived value.

As a fall back the Members Data Transfer procedure may be used by all members to refresh their information on the available members by requesting update from the MASTER. For these purposes the PT initiated parameter retrieval procedure shall be used.

Table E.3: Values used within the {MM-INFO-REQUEST} message

Information element	Field within the information element	Standard values within the field/IE	Normative action/comment
<<Info-type>>			
	<Length of Contents >	00000001	
	<ext>	1	
	<Parameter type>	0100101	Distributed Communication download
<<IWU-TO-IWU>>			This information element need to be included only if information for particular member is required as indicated in the <Terminal Id> field If it is not included the request shall be understood as request for information for all DCDL-net members
	<S/R>	1	Transmission of message
	<Protocol discriminator>	0100011	Terminal Data
	<Discriminator Type>	0001	HyP Information
	<Command/Action>	0001	capabilities
	<Length of Contents>>	All	Determines whether the <Terminal data> field is included or not
	<Terminal type>	Any	Any relevant, see subclause E.4.2
	<Extended capabilities>	Any	Any relevant, see subclause E.4.2
	<Terminal Id>	All	IdN - Mean to distinguish different terminals

### E.3.5 Presence/Absence Indication

A member shall indicate the MASTER whether it is accessible or not.

To indicate that it is accessible the Attach (Location registration) procedure shall be used.

To indicate that it is inaccessible the Detach procedure shall be used.

### E.3.6 Bandwidth management

When a member would like to establish a call to another member all DCDL-net bandwidth may be in use from other members or may not be sufficient for satisfactory grade of service.

To acquire some bandwidth the member shall request assistance from the MASTER.

On receipt of a bandwidth management assistance request, the MASTER shall broadcast a connectionless message to all involved in communications terminals requiring bandwidth reduction and providing maximum time during which the freed bearers shall not be re-targeted. All communicating terminals, providing that sufficient bandwidth is available to maintain the communication, shall reduce the number of used bearers in number equivalent to a duplex bearer (a peer of bearers 12 slots apart). The freed bearers may be re-targeted for use after the allocated duration time expires.

During this time the member which intended communication may establish the desired call using the freed slots.

To requests bandwidth management assistance from the MASTER the terminal in need shall send a {CLMS-VARIABLE} message to the MASTER utilizing the unused half of the double slot on which the System Control Bearer is transmitted according to the rules in EN 300 175-3 [3]. To reduce the time limits of transmission enforced by the MAC layer CL protocol, the usage of CLF channel is recommended.

Table E.4: Values used within the {CLMS-VARIABLE} message

Information element	Field within the information element	Standard values within the field/IE	Normative action/comment
<<Portable Id>>			"0" length
<<IWU-TO-IWU>>			
	<S/R>	1	Transmission of message
	<Protocol discriminator>	0100011	Terminal Data
	<Discriminator Type>	0001	HyP Information
	<Command/Action>	1001	Reduce number of bearers
	<Length of Contents>>	00000001	
	<Terminal type>	00000000	Unknown
	<Extended capabilities>	00000000	
	<Terminal Id>	All	IdN of the sender

After reception of this request the MASTER shall request all or a set of involved in communication members to reduced the number of used bearers by sending a {CLMS-FIXED} message.

Table E.5: Values used within the {CLMS-FIXED} message for bandwidth change

Information element	Field within the information element	Standard values within the field/IE	Normative action/comment
<<A>>		1	Address section
<<CLMS header>>		011	One section/Bit stream
<<Address>>		Any	lowest 16 bits of connectionless TPUI when one HyP is addressed, or, the last 16 bits of the CBI, see EN 300 175-6 [6] subclause 6.3.1 when all the HyPs are addressed.
<<Protocol Discriminator>>	<Identifier>	0001	Distributed Communications
	<Command/Action>	1001	Reduce number of bearers
<<Data>>		Any	Time limit during which increase of number of used bearers is not allowed The time duration is binary coded (bit 1 being the least significant bit). The time duration defines time in units based on the MAC layer multiframes. Multiframes are defined in EN 300 175-3 [3]. 1 unit = 28 multiframes

Whenever a terminal that is involved in communication receives this message, and, the received Connectionless TPUI matches one of the terminal's Connectionless TPUIs the Terminal shall try to reduce the number of bearers it is currently using.

At some cases however, reduction may not be possible - e.g. the lowest numbers of bearers necessary for maintaining the communication have been used. In such a case the terminal may decide to enforce a suspend procedure (if possible), or, need not to reduce the number of used bearers.

### E.3.7 Direct Link Establishment

At any time an active member may initiate direct link establishment by a bearer establishment procedure as the bearer request may be placed in any slot.

For establishing a new link a HyP shall use the PT initiated bearer establishment procedure as defined in EN 300 175-3 [3]. During the existence of a link the roles of the involved terminals shall be as allocated at the beginning of the link establishment: the initiating HyP shall be recognized and use its PMID; the responding HyP shall be recognized and use its FMID. For the case of communication between a HyP and a voice PT other requirements may apply (e.g. defined in applicable profiles).

A terminal should not attempt bearer establishment with a member that is not indicated as being currently active.

A bearer establishment may fail even the called terminal has been indicated as currently active, e.g. the called terminal is in low duty cycle mode. In such case the Indirect Link Establishment procedure should be used as described in subclause E.3.8. In any case when a HyP is listening for direct link establishment it shall listen for request on any slot.

NOTE: It may happen that though 2 terminals have registered to the MASTER they still cannot establish direct communication, e.g. due to range problems when both are at opposite sides of the MASTER. In such case normally few failures of direct communication should lead to attempt of communication through the MASTER (internal call).

A MASTER may use paging for the purpose of establishing communication with another member of the DCCL-net.

### E.3.8 Indirect Link Establishment

If a direct link establishment procedure to a particular terminal has failed the calling terminal shall request assistance from the MASTER by issuing a connectionless up-link requests providing the IdN of the targeted terminal, as well as, its own Id.

**Table E.6: Values used within the {CLMS-VARIABLE} message**

Information element	Field within the information element	Standard values within the field/IE	Normative action/comment
<<Portable Id>>			"0" length, see note
<<IWU-TO-IWU>>			
	<S/R>	1	Transmission of message
	<Protocol discriminator>	0100011	Terminal Data
	<Discriminator Type>	0001	HyP Information
	<Command/Action>	1010	Page assistance
	<Length of Contents>>	00000001	
	<Target Terminal Id>	All	IdN of the intended for connection terminal
	<Initiator Terminal Id>	All	IdN of the seeking connection terminal
NOTE:	Inclusion of Portable Identity with length "0" is introduced in order to reduce the total length of the message. By this and adding the second Terminal Id the gain is 4 octets less length of the message compare to the case of providing the Caller Id in the portable identity information element.		

To reduce the time limits of transmission enforced by the MAC layer CL protocol, see EN 300 175-3 [3] the usage of CLF channel is recommended. The slot used for the transmission should be the reverse half of the DCCL-net System Control Bearer.

A terminal shall not initiate this procedure if the desired terminal is not indicated as currently available in the Active Members List distributed by the MASTER.

On receipt of the request the MASTER shall send a Connectionless message indication to the called terminal providing the IdN of the calling terminal. If the called terminal is not available the MASTER should ignore the request.

**Table E.7: Values used within the {CLMS-FIXED} message one segment**

Information element	Field within the information element	Standard values within the field/IE	Normative action/comment
<<A>>		1	Address section
<<CLMS header>>		011	One section/Bit stream
<<Address>>		Any	lowest 16 bits of connectionless TPU1
<<Protocol Discriminator>>	<Identifier>	0001	Distributed Communications
	<Command/Action>	1011	direct link establishment
<<Data>>		Any	IdN of the terminal that requested the assistance - the receiver shall use this to identify to which terminal to initiate a direct link establishment

The called terminal should initiate direct link establishment to the calling terminal. As it may not be for whatever reason capable of doing this, the initiating terminal should not wait for ever. It may repeat the procedure max 3 times and in case of all 3 attempts have failed the user should be informed for the call attempt failure.

## E.3.9 MASTER management

### E.3.9.1 MASTER assign

For setting up a DCDL-net a MASTER terminal is needed which shall transmit a System Control Bearer. The User shall ensure that a MASTER is available which MASTER shall start transmission of such a bearer on User request for setting-up a DCDL-net. The invocation of MASTER assign procedure is not specified and is left to the implementers assuming that User intervention shall be always required.

If a DCDL-net has been already set-up, however, during a reasonable time a member of a DCDL-net terminal cannot find the DCDL-net System Control Bearer proper indication shall be provided to the User of the terminal.

The DCDL-net System Control bearer shall be a connectionless bearer due to the fact that the DCDL-net system information it transmitted in connectionless messages.

If a member of DCDL-net has been assigned as MASTER this shall be responsible for the transmission of the Connectionless DCDL-net system bearer. This bearer shall be present if at least one member of a DCDL-net is active.

Establishment and maintenance of this bearer shall be done in accordance to the requirements of the EN 300 175-3 [3].

### E.3.9.2 MASTER Change

If a MASTER is to leave the DCDL-net it shall allocate any of the currently active members as its successor. A connectionless message shall be sent.

**Table E.8: Values used within the {CLMS-FIXED} message one segment**

Information element	Field within the information element	Standard values within the field/IE	Normative action/comment
<<A>>		1	Address section
<<CLMS header>>		011	One section/Bit stream
<<Address>>		Any	lowest 16 bits of connectionless TPU1
<<Protocol Discriminator>>	<Identifier>	0001	Distributed Communications
	<Command/Action>	1100	master change
<<Data>>		Any	do not care bits

The current MASTER shall start a timer and shall monitor the air for a new System Control Bearer establishment - a value of 4 sec is recommended. When such is found the current MASTER shall inform all active members for the change of the bearer position and shall close its activities - "connectionless or dummy bearer position" shall be used.

If during this time no new System bearer is found the MASTER shall request another active member to undertake its responsibilities.

### E.3.9.3 DCDL-net System bearer management

The System bearer shall be a connectionless bearer as defined in EN 300 175-3 [3].

In addition to the information normally transmitted when no additional dummy bearer is available, the MASTER shall transmit specific DCDL-net members related information in regular intervals - it is recommended that the first segment of this message occurs every 4 seconds.

Table E.9: Values used within the {CLMS-FIXED} message 1st segment

Information element	Field within the information element	Standard values within the field/IE	Normative action/comment
<<A>>		1	Address section
<<CLMS header>>		100	Multiple sections/Bit stream
<<Address>>		Any	lowest 16 bits of connectionless TPUI
<<Protocol Discriminator>>	<Identifier>	0001	Distributed Communications
	<Command/Action>	1101	active members list
<<Length Identifier>>		Any	Indicates implicitly the number of data sections to follow.

Table E.10: Values used within the {CLMS-FIXED} message 2nd segment

Information element	Field within the information element	Standard values within the field/IE	Normative action/comment
<<A>>		0	Data section
<<CLMS header>>		000	Data section number - 0 (1st)
<<DATA/Fill>>		IN1	IdN number of an active terminal
		IN2 /Fill	IdN number of an active terminal
		IN3 /Fill	IdN number of an active terminal
		IN4 /Fill	IdN number of an active terminal

Table E.11: Values used within the {CLMS-FIXED} message k segment

Information element	Field within the information element	Standard values within the field/IE	Normative action/comment
<<A>>		0	Data section
<<CLMS header>>		k	Data segment (k +1)
<<DATA/Fill>>		IN4k+1	IdN number of an active terminal
		IN4k+2 /Fill	IdN number of an active terminal
		IN4k+3 /Fill	IdN number of an active terminal
		IN4k+4 /Fill	IdN number of an active terminal

## E.3.10 Common Subscription Database management

### E.3.10.1 IdN

Each member of a DCDL-net shall be assigned an Identity Number (IdN) which shall be of 8 bits length thereby providing 255 distinguishable numbers for 255 possible members of a DCDL-net.

### E.3.10.2 RFPI, PARK and PLI

A DCDL-net is recognized by an ARI, a Common PARK and number of Members specific RFPIs.

For allocation of DCDL-net Common PARK and Members specific RFPIs, a DCDL-net System ARI shall be used. This shall be a unique ARI of this DCDL-net which shall be broadcasted by the MASTER and used for locking and obtaining system information.

For a given DCDL-net ARI the following rules in accordance to EN 300 175-6 [6] shall apply:

- the DCDL-net PARK should equal this ARI
- for one cell systems or systems in which inter-cell handover is not foreseen the members specific RFPIs shall be based on an ARI that equals the DCDL-net ARI, the E bit should be set to 0 and the RPN shall equal the member's IdN (this means that if the RPN in use is only of 3 bits length the assignment of the IdN shall reflect this limitation and the unused MSB shall be set to 0).
- for multi-cell systems (determined by multi RFPs MASTER) with inter-cell handover care shall be taken during allocation providing that the MASTERS RFPs are assigned with IdNs allowing inter-cell handover and being still unique (e.g. not repeating a member IdN). See as well subclause E.3.11.

NOTE: For further extension of this specification assignment of a per Member specific DCDL-net Cell Locator may be foreseen to allow Members to be multi-cell systems as well.

PLI should be assign to cover the PARI and to exclude the RPN.

### E.3.10.3 IPUI

For the member specific IPUIs the IPUI type O as specified in EN 300 175-6 [6] subclause 6.2.3 should be used.

Different Numbers shall be assigned to every member of the DCDL-net, these numbers shall be used to identify every particular member and provide means to derive all subscription related data.

For the assignment of these numbers the following rule apply: the 8 least significant bits shall be the IdN number and they shall be unique within the DCDL-net. The rest of the bits shall be set to "0".

### E.3.10.4 TPUI and LAL

The LAL assigned during Location registration should be the same throughout the entire DCDL-net.

The individual assigned TPUI shall equal the IdN of the particular terminal with most significant bits following the rules of EN 300 175-6 [6] for individual assigned TPUI.

To perform all connectionless operations the MASTER shall assign Connectionless TPUIs to each member that equal the member's IdN with most significant bits following the rules of EN 300 175-6 [6] for.

### E.3.10.5 Keys

A common AC shall be allocated to the DCDL-net by the user and shall be used during subscription and throughout the intra DCDL-net communication whenever authentication between two members is performed.

If encryption is supported a Static CK shall be allocated to the DCDL-net during the first subscription. Establishment of this key should be based on a Store DCK procedure performed using the AC, other proprietary establishment of this key may be applied by the MASTER as well. The resulted key shall be the SCK used by the DCDL-net for further communication.

## E.3.11 Handover issues

For one cell systems bearer handover shall be used to deal with transmission problems.

The MASTER may decide to change the position of the System Control Bearer. The new position shall be announced. As the new position may overlap with a slot on which there is ongoing communication between two members of the DCDL-net, as soon as these members receive the new System Control Bearer slot position they shall attempt handover for the bearer(s) which will overlap.

When the MASTER provides multi-cell environment, the Members should forbid inter-cell handover.

## E.4 Elements of Messages/Information Elements

This clause specifies in details the complete contents of the messages/information elements used by the Distributed Communication Protocol which introduce modifications to the existing DECT protocol specification. Differences to the current DECT specification as in EN 300 175-5 [5] are underlined and due to submission as CRs to EP DECT.

### E.4.1 CLMS-FIXED

**Table E.12: Values used within the {CLMS-FIXED} message one segment**

Information element	Field within the information element	Standard values within the field/IE	Normative action/comment
<<A>>		1	Address section
<<CLMS header>>		011	One section/Bit stream
<<Address>>		Any	lowest 16 bits of connectionless TPUI
<<Protocol Discriminator>>	<Identifier>	0001	Distributed Communications
	<Command/Action>	1001	Reduce number of bearers
		1010	Page assistance
		1011	direct link establishment
		1100	master change
		1101	active members list
<<Data>>		Any	Contents depends on the <Command/Action> field as described in relevant clause in the present document.

For constructing a multi-section {CLMS-FIXED} message the rules as defined in EN 300 175-5 [5] apply.



## E.4.2 IWU-TO-IWU

Table E.13: Values used within the &lt;&lt;IWU-TO-IWU&gt;&gt; Information element for &lt;Command/action&gt; set to "capabilities"

<<IWU-TO-IWU>>			Preceding octets as defined in EN 300 175-5 [5]
	<ext3>	1	
	<S/R>	1/0	Transmission of message
	<Protocol discriminator>	100011	Terminal Data
	<Discriminator Type>	0001	HyP Information
		0000	PP Information
		0010	FP Information
	<Command/Action>	0001	capabilities
	<Length of Contents>>	All	
	<Terminal type>	00000000	unknown
		00000001	PC
		00000010	Printer
		00000011	Scanner
		00000100	Digital Camera
		00000101	Modem
		00000110	Palmheld
		00001000	Voice
		00001001	External line connector (e.g. an ISDN base)
		***	more to be defined
	<Extended capability>		A bit mask
		xxxxxxx1	the device is able to perform internal calls
		xxxxxxx1x	the device is able to perform more than on simultaneous calls
		xxxxx1xx	the device provides access to external line
	<Terminal Id>	All	IdN of the concerned terminal - depends on the values indicated into the <Discriminator type> and the <Command/Action>
	<Terminal data>		The information provided shall be in the form of complete information elements as specified in EN 300 175-5 [5], e.g. <<Terminal capability>>, <<Key>>, <<Portable Identity>>, etc.

Table E.14: Values used within the &lt;&lt;IWU-TO-IWU&gt;&gt; Information element for &lt;Command/action&gt; set to "Page Assistance"

<<IWU-TO-IWU>>			
	<S/R>	1	Transmission of message
	<Protocol discriminator>	0100011	Terminal Data
	<Discriminator Type>	0001	HyP Information
		0000	PP Information
	<Command/Action>	1010	Page assistance
	<Length of Contents>>	00000001	
	<Target Terminal Id>	All	IdN of the intended for connection terminal
	<Initiator Terminal Id>	All	IdN of the seeking connection terminal

## E.4.3 Info-type

**Table E.15: Values used within the <<Info type>> Information element**

<<Info-type>>			
	<Length of Contents >	00000001	
	<ext>	1	
	<Parameter type>	0100101	Distributed Communication download

## E.4.4 CLMS-VARIABLE

The {CLMS-VARIABLE} shall be constructed in accordance to the requirements of EN 300 175-5 [5]. The mandatory information elements are indicated below.

**Table E.16: Values used within the {CLMS-VARIABLE} message**

Information element	Field within the information element	Standard values within the field/IE	Normative action/comment
<<Portable Id>>			contents as specified in the related procedure
<<IWU-TO-IWU>>			contents as specified in the related procedure

---

## E.5 Examples

### E.5.1 General

To ease understanding this annex provides some examples.

For these examples the following basic user configuration is used:

- there are two PCs - PC\_1 and PC\_2 which are connected to a HyP terminals each;
- there is a Printer connected to a HyP terminal, here called "Print";
- there is a Scanner connected to a HyP terminal, here called "Scan";
- there is a Digital Camcorder connected to a HyP terminal, here called "D-Cam";
- there is a GAP voice Portable, here called "Handy";
- there is a Base Station called in here "Switch" (a HyP terminal from type External Line Connector) connected to an external line;
- there is Palmheld computer (organizer, etc.) connected to a HyP terminal, here called "PalmH".

A DCDL-net has been set-up comprising all the eight DECT terminals. The Switch has been assigned as the MASTER of this DCDL-net. Consequently the Switch is transmitting the DCDL-net System Control Bearer. When powered-on all terminals (except the Switch) locked to the MASTER, synchronize, obtain all information relevant to this DCDL-net (e.g. which are the present members, etc.) and are able to set-up connection directly to desired member of the DCDL-net.

## E.5.2 Example 1

In this example all except the Handy and the Switch (MASTER) terminals are switched-off. The Handy is performing a voice session through the Switch and the External network to a far-end terminal.

Using the existing spectrum of 240 slots:

- the Master is transmitting the System Control Bearer occupying a connectionless bearer - 2 slots;
- the session between the Handy and the Switch is occupying 2 slots ( a duplex channel).

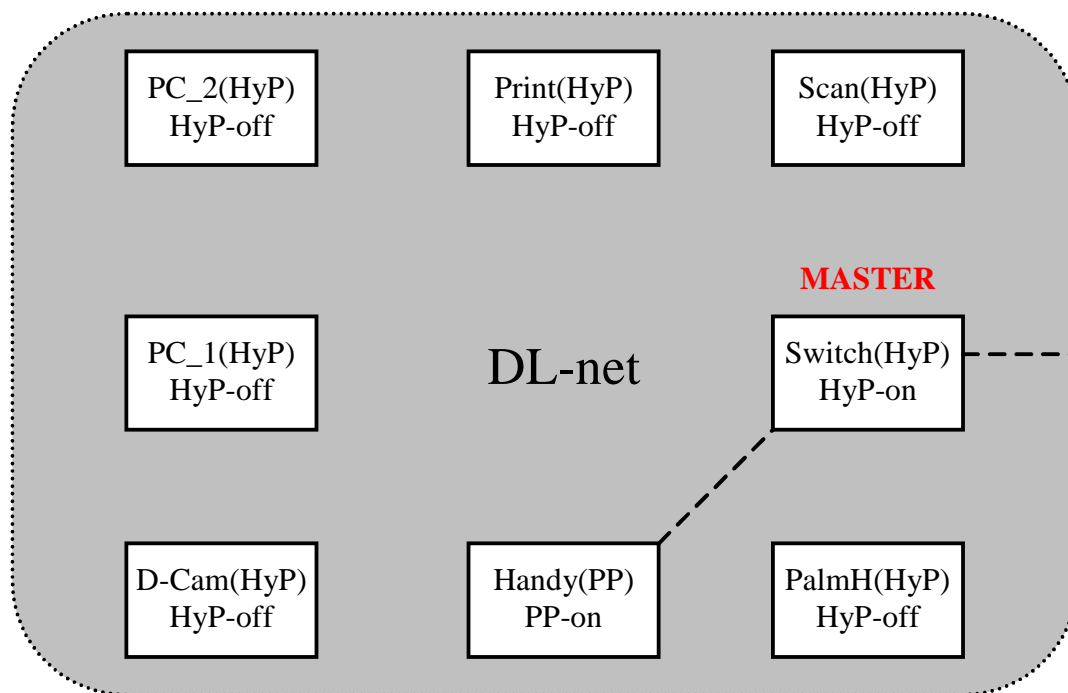

Figure E.1: DL-net - only voice communication enabled - Handy locked to Switch

## E.5.3 Example 2

In this scenario the Handy is continuing its Voice session, and, all the rest of the terminals have been switched-on.

Using the existing spectrum of 240 slots:

- the Master is transmitting the System Control Bearer occupying a connectionless bearer - 2 slots;
- the session between the Handy and the Switch is occupying 2 slots ( a duplex channel);
- PC\_2 is printing having a direct communication with the Printer using let us say 1 duplex and 2 simplex bearers; (4 slots);
- the D-Cam is uploading images to PC\_1 using another 4 slots (1 duplex and 2 simplex bearers).

All in total 12 slots are in use. For comparison, if all the links had to be performed through the Switch (a FP) 20 slots should have been in used.

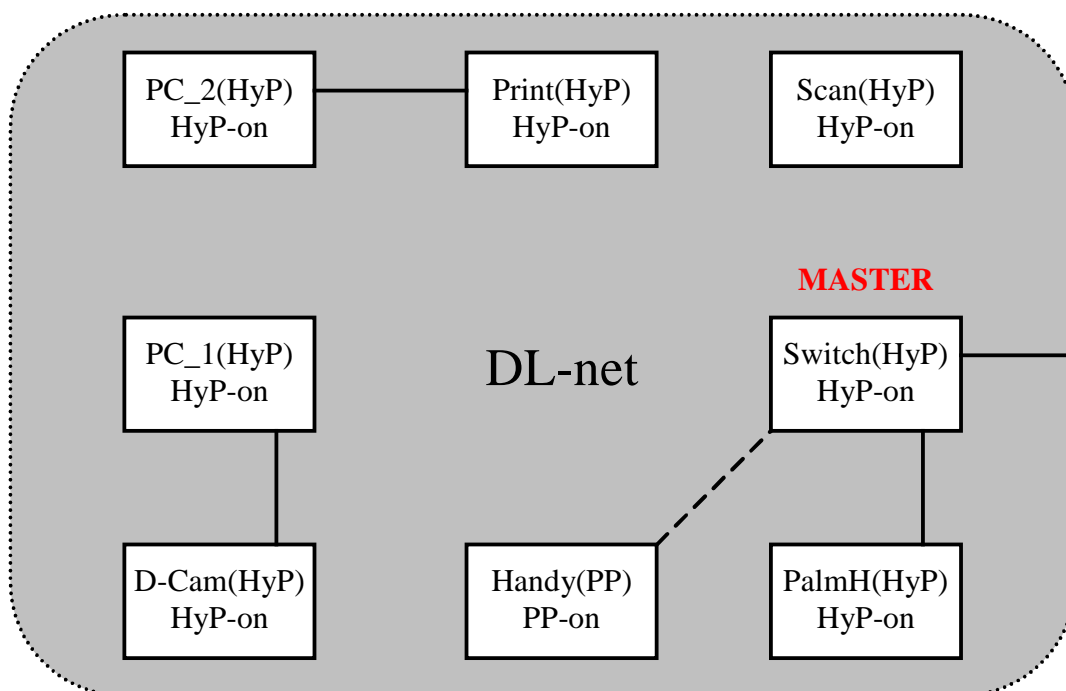

**Figure E.2: DL-net communication - PC\_2 prints; D-CAM uploads to PC\_1; Handy locked to Switch; PalmH gets mails; Scan inactive**

### E.5.4 Example 3

In this scenario the Handy is continuing its Voice session, PC\_2 is still printing, and, all the rest of the terminals have been switched-on.

PC\_1 has established a direct link to the Print as well.

Using the existing spectrum of 240 slots:

- the Master is transmitting the System Control Bearer occupying a connectionless bearer - 2 slots;
- the session between the Handy and the Switch is occupying 2 slots ( a duplex channel);
- a session between the PalmH and the Switch is occupying 2 slots (e.g. Internet session in parallel to a voice one for Switch connected to ISDN);
- PC\_2 is printing having a direct communication with the Printer using let us say 1 duplex and 2 simplex bearers (4 slots);
- the PC\_1 is printing using another 4 slots (1 duplex plus 2 simplex bearers);
- Print, as well as, Switch are handling two parallel links.

All in total 14 slots are in use. For comparison, if all the links had to be performed trough the Switch (a FP) 22 slots should have been in used.

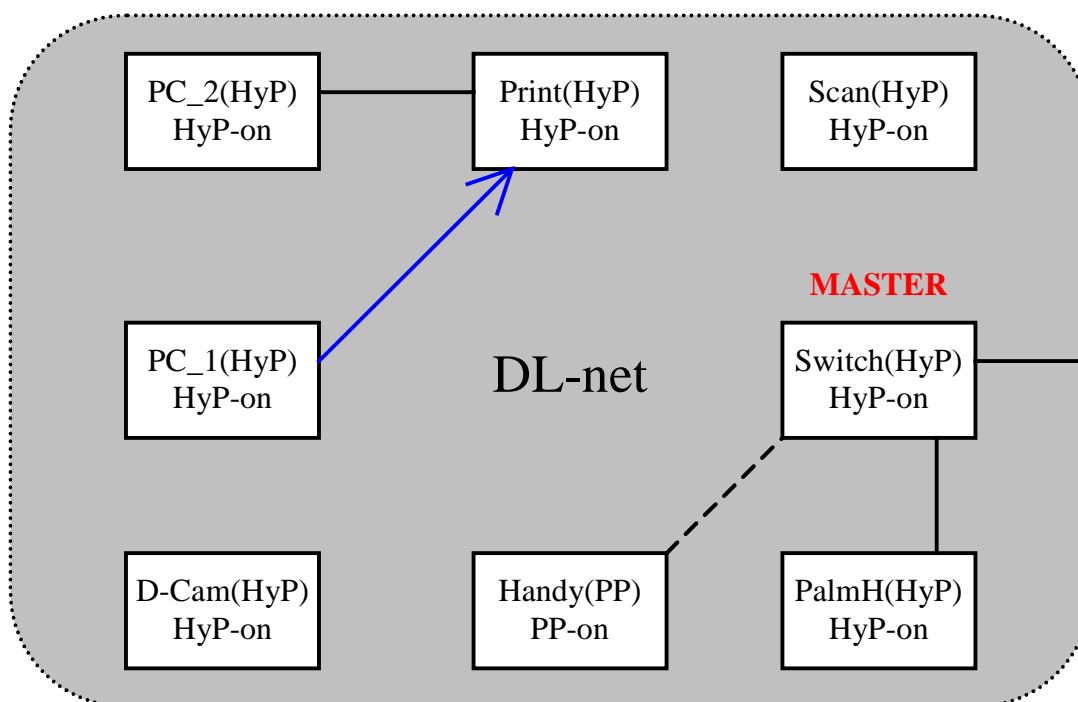

**Figure E.3: DL-net communication - PC\_2 prints; PC\_1 prints (direct link establishment); D-CAM inactive; Handy locked to Switch; PalmH gets mails; Scan inactive**

### E.5.5 Example 4

In this scenario the Handy is continuing its Voice session, PC\_2 is still printing, and, all the rest of the terminals have been switched-on.

In this special example PC\_1 has not been able to successfully perform the direct link establishment procedure to Print (e.g. after being engaged with PC\_2 Print does not listen to other bearer establishment attempts).

PC\_1 has requested assistance from the MASTER in achieving the communication to the Print. The MASTER has send a CL message to the Print requesting it to communicate to PC\_1. Print has not miss it as it is required to listen to the System Control Bearer on which the indication was transmitted.

Finally, Print has establish link to PC\_1 and PC\_1 is able to print.

Using the existing spectrum of 240 slots:

- the Master is transmitting the System Control Bearer occupying a connectionless bearer - 2 slots;
- the session between the Handy and the Switch is occupying 2 slots ( a duplex channel);
- a session between the PalmH and the Switch is occupying 2 slots (e.g. Internet session in parallel to a voice one for Switch connected to ISDN);
- PC\_2 is printing having a direct communication with the Printer using let us say 1 duplex and 2 simplex bearers (4 slots);
- the PC\_1 is printing using another 15 slots (1 duplex plus13 simplex);
- Print, as well as, Switch are handling two parallel links.

All in total 25 slots are in use. In order to work this scenario requires from the involved terminals usage of some same slots on different frequencies which will be possible depending on the location of the terminals.

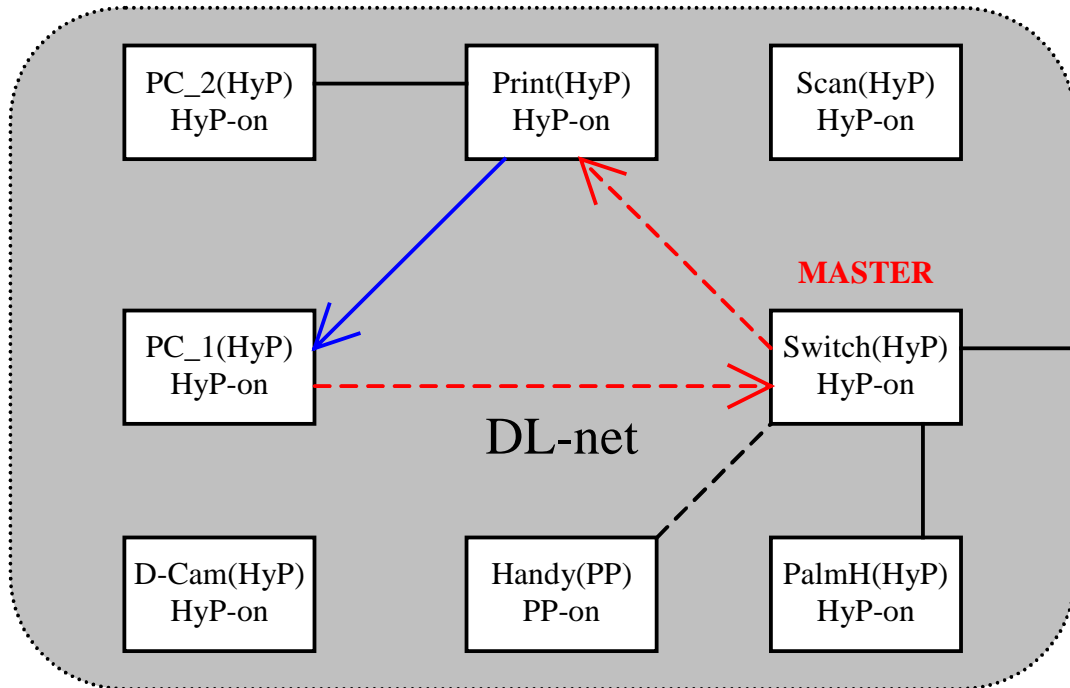

Figure E.4: DL-net communication - PC\_2 prints; PC\_1 prints (Indirect link establishment); D-CAM inactive; Handy locked to Switch; PalmH gets mails; Scan inactive

## E.6 Usage of PPs or FPs in DCDL-net

### E.6.1 General

Apart from HyPs terminals, normal PPs and FPs can become members of a DCDL-net.

Such terminals need to support some of the procedures described earlier in the present document. This subclause describes the necessary requirements.

### E.6.2 Requirements to FPs

#### E.6.2.1 General

A FP can be a member of a DCDL-net only in the role of a MASTER. To operate as MASTER a FP shall support the procedures as indicated in the table below.

**Table E.17: Support of DCDL-net procedures for a member of type FP**

Procedure	Support	Comments
Membership Access Rights Allocation	YES	the MASTER related issues
Re-initialization of membership access rights	YES	the MASTER related issues
Members Data Transfer	YES	the MASTER related issues
Presence/Absence Indication	YES	To understand and handle initiation of this
Bandwidth management	YES	the MASTER related issues
Direct Link Establishment	OPTIONAL to initiate MANDATORY to response	the MASTER related issues
Indirect Link Establishment	YES	the MASTER related issues
MASTER management - MASTER assign	YES	the MASTER related issues
MASTER management - MASTER Change	YES	the MASTER related issues
MASTER management - DCDL-net System bearer management	YES	the MASTER related issues
Common Subscription Database management - RFPI, PARK and PLI	YES	the MASTER related issues
Common Subscription Database management - IPU	YES	the MASTER related issues
Common Subscription Database management - TPUI and LAL	YES	the MASTER related issues
Common Subscription Database management - Keys	YES	the MASTER related issues

Modification to this procedure wherever required are described in the following subclauses.

#### E.6.2.2 Members Data Transfer

The requirements as in subclause E.3.4 shall apply with the following modification.

A FP can be distinguish from a HyP by the indication in the <Discriminator type>:

**Table E.18: Discriminator type for PP**

<<IWU-TO-IWU>>	<Discriminator Type>	0010	FP Information
----------------	----------------------	------	----------------

### E.6.2.3 Direct Link Establishment

The requirements as in subclause E.3.7 shall apply with the following modification.

The FT may be able to listen on all 0 to 23 slots but is not required. If the FT is not able to listen on the frame half designated for FT transmission such a FT can be accessed only when the request for communication is put in the half of the frame designated for the PT transmission, see subclause E.6.4.

## E.6.3 Requirements to PPs

### E.6.3.1 General

A PP can be a member of a DCDL-net but not in the role of a MASTER. To operate as a member a PP shall support the procedures as indicated in the table below.

**Table E.19: Support of DCDL-net procedures for a member of type PP**

Procedure	Support	Comments
Membership Access Rights Allocation	YES	the NON MASTER related issues
Re-initialization of membership access rights	YES	the NON MASTER related issues
Members Data Transfer	YES	the NON MASTER related issues
Presence/Absence Indication	YES	To be able to announce this
Bandwidth management	YES	the NON MASTER related issues
Direct Link Establishment	MANDATORY to initiate & response	the NON MASTER related issues
Indirect Link Establishment	YES	the NON MASTER related issues
MASTER management - MASTER assign	YES	the NON MASTER related issues, e.g. understanding and reacting properly to the MASTER behaviour
MASTER management - MASTER Change	YES	the NON MASTER related issues, e.g. understanding and reacting properly to the MASTER behaviour
MASTER management - DCDL-net System bearer management	YES	the NON MASTER related issues, e.g. understanding and reacting properly to the MASTER behaviour
Common Subscription Database management - RFPI, PARK and PLI	YES	the NON MASTER related issues, e.g. to manage the assignment/usage of related identities
Common Subscription Database management - IPUI	YES	the NON MASTER related issues, e.g. to manage the assignment/usage of related identities
Common Subscription Database management - TPUI and LAL	YES	the NON MASTER related issues, e.g. to manage the assignment/usage of related identities
Common Subscription Database management - Keys	YES	the NON MASTER related issues, e.g. to manage the assignment/usage of related keys

Modification to this procedure wherever required are described in the following subclauses.

### E.6.3.2 Membership Access Rights Allocation

The requirements as in subclause E.3.2 shall apply with the following modification.

The PP shall indicate that this is a PP:

**Table E.20: Values for capability description used within the {ACCESS-RIGHTS-REQUEST} message**

<<IWU-TO-IWU>>	<Discriminator Type>	0000	PP Information
----------------	----------------------	------	----------------



### E.6.3.3 Members Data Transfer

The requirements as in subclause E.3.4 shall apply with the following modification.

A PP can be distinguish from a HyP by the indication in the <Discriminator type>:

**Table E.21: Discriminator type for PP**

<<IWU-TO-IWU>>			
	<Discriminator Type>	0000	PP Information

### E.6.3.4 Direct Link Establishment

The requirements as in subclause E.3.7 shall apply with the following modification.

The PT may be able to listen on all 0 to 23 slots but is not required. If the PT is not able to listen on the frame half designated for PT transmission such a PT can be accessed only via Paging from the MASTER as described in subclause E.3.8 Indirect Link Establishment.

Direct Communication between two PTs that both are not able to listen on the frame half designated for PT transmission is not possible.

However, such PT s could still communicate one with another via a FP or HyP that supports internal calls as indicated in the field <Extended capabilities> of the <<IWU-TO-IWU>> information element.

### E.6.3.5 Indirect Link Establishment

The requirements as in subclause E.3.8 shall apply with the following modification.

A PP can be distinguish from a HyP by the indication in the <Discriminator type>:

**Table E.22: Discriminator type for PP**

<<IWU-TO-IWU>>			
	<Discriminator Type>	0000	PP Information

## E.6.4 Handling of PP and FP by a HyP

The type of a terminal shall be established based on the information provided into the field <Discriminator Type> in the <<IWU-TO-IWU>> information element.

When a HyP recognizes that the MASTER is a FP it shall not use the frame half that is designated for FT transmission for setting-up bearers and transmitting any information to this FT.

When a HyP recognizes that a member of the DCDL-net is from type PP it may still try direct communication placing the request in any slot. In any case if the PP does not answer or without any direct attempts the HyP shall request the MASTER to page such PPs.

---

## History

<b>Document history</b>			
V0.0.2	March 1999	Public Enquiry	PE 9927: 1999-03-05 to 1999-07-02
V0.5.1	November 1999	Vote	V 200001: 1999-11-08 to 2000-01-07
V1.1.1	March 2000	Publication	