

Draft **ETSI EN 301 489-25** V2.3.2 (2004-07)

Candidate Harmonized European Standard (Telecommunications series)

**Electromagnetic compatibility
and Radio spectrum Matters (ERM);
ElectroMagnetic Compatibility (EMC)
standard for radio equipment and services;
Part 25: Specific conditions for CDMA 1x
Spread Spectrum Mobile Stations and ancillary equipment**



Reference

REN/ERM-EMC-240-25

Keywords

cdma2000, EMC, IMT-2000, radio, regulation,
terminal

ETSI

650 Route des Lucioles
F-06921 Sophia Antipolis Cedex - FRANCE

Tel.: +33 4 92 94 42 00 Fax: +33 4 93 65 47 16

Siret N° 348 623 562 00017 - NAF 742 C
Association à but non lucratif enregistrée à la
Sous-Préfecture de Grasse (06) N° 7803/88

Important notice

Individual copies of the present document can be downloaded from:

<http://www.etsi.org>

The present document may be made available in more than one electronic version or in print. In any case of existing or perceived difference in contents between such versions, the reference version is the Portable Document Format (PDF). In case of dispute, the reference shall be the printing on ETSI printers of the PDF version kept on a specific network drive within ETSI Secretariat.

Users of the present document should be aware that the document may be subject to revision or change of status. Information on the current status of this and other ETSI documents is available at

<http://portal.etsi.org/tb/status/status.asp>

If you find errors in the present document, send your comment to:

editor@etsi.org

Copyright Notification

No part may be reproduced except as authorized by written permission.
The copyright and the foregoing restriction extend to reproduction in all media.

© European Telecommunications Standards Institute 2004.
All rights reserved.

DECT™, **PLUGTESTS™** and **UMTS™** are Trade Marks of ETSI registered for the benefit of its Members.
TIPHON™ and the **TIPHON logo** are Trade Marks currently being registered by ETSI for the benefit of its Members.
3GPP™ is a Trade Mark of ETSI registered for the benefit of its Members and of the 3GPP Organizational Partners.

Contents

Intellectual Property Rights	5
Foreword.....	5
1 Scope	6
2 References	6
3 Definitions and abbreviations.....	7
3.1 Definitions	7
3.2 Abbreviations	7
4 Test conditions	8
4.1 General	8
4.2 Arrangements for test signals	8
4.2.1 Arrangements for test signals at the input of transmitters.....	9
4.2.2 Arrangements for test signals at the output of transmitters.....	9
4.2.3 Arrangements for test signals at the input of receivers	9
4.2.4 Arrangements for test signals at the output of receivers	9
4.3 Exclusion bands.....	9
4.3.1 Transmitter exclusion band.....	9
4.3.2 Receiver exclusion band	10
4.4 Narrow band responses on receivers	10
4.5 Normal test modulation	10
5 Performance assessment.....	10
5.1 General	10
5.2 Equipment which can provide a continuous communication link	10
5.3 Equipment which does not provide a continuous communication link	11
5.4 Ancillary equipment	11
5.5 Equipment classification	11
6 Performance criteria	11
6.1 General	11
6.2 Performance criteria for continuous phenomena.....	11
6.3 Performance criteria for transient phenomena.....	12
7 Applicability overview tables.....	12
7.1 Emission.....	12
7.1.1 General.....	12
7.1.2 Special conditions.....	12
7.2 Immunity	12
7.2.1 General.....	12
7.2.2 Special conditions.....	12
Annex A (informative): Examples of mobile and portable radio and ancillary equipment within the scope of the present document.....	13
A.1 Mobile and portable radio equipment, and ancillary equipment for IMT-2000 CDMA Multi- carrier Systems	13
A.2 Mobile and portable radio equipment, and ancillary equipment for CDMA-PAMR Systems	13
Annex B (normative): Performance assessment voice call. Audio break through.....	14
B.1 Calibration of audio levels	14
B.2 Measurement of audio levels.....	15
Annex C (normative): Performance assessment of data transfer call. Error Rates.....	16
C.1 Calibration of data transfer.....	16

C.2	Derivation of Error Rates	16
C.3	EUT without data application ancillary.....	17
C.4	EUT with data application ancillary.....	17
Annex D (informative):	Bibliography.....	18
Annex E (informative):	The EN title in the official languages	19
History		20

Intellectual Property Rights

IPRs essential or potentially essential to the present document may have been declared to ETSI. The information pertaining to these essential IPRs, if any, is publicly available for **ETSI members and non-members**, and can be found in ETSI SR 000 314: "*Intellectual Property Rights (IPRs); Essential, or potentially Essential, IPRs notified to ETSI in respect of ETSI standards*", which is available from the ETSI Secretariat. Latest updates are available on the ETSI Web server (<http://webapp.etsi.org/IPR/home.asp>).

Pursuant to the ETSI IPR Policy, no investigation, including IPR searches, has been carried out by ETSI. No guarantee can be given as to the existence of other IPRs not referenced in ETSI SR 000 314 (or the updates on the ETSI Web server) which are, or may be, or may become, essential to the present document.

Foreword

This Candidate Harmonized European Standard (Telecommunications series) has been produced by ETSI Technical Committee Electromagnetic compatibility and Radio spectrum Matters (ERM), and is now submitted for the Public Enquiry phase of the ETSI standards Two-step Approval Procedure.

The present document has been produced by ETSI in response to a mandate from the European Commission issued under the Council Directive 98/34/EC [4] (as amended) laying down a procedure for the provision of information in the field of technical standards and regulation.

The present document, together with EN 301 489-1 [1], is intended to become a Harmonized Standard, the reference of which will be published in the Official Journal of the European Communities referencing the Council Directive on the approximation of the laws of the Member States relating to ElectroMagnetic Compatibility ("the EMC Directive") (89/336/EEC [3] as amended) and Directive 1999/5/EC [2] of the European Parliament and of the Council of 9 March 1999 on radio equipment and telecommunications terminal equipment and the mutual recognition of their conformity ("the R&TTE Directive").

The present document is part 25 of a multi-part deliverable. Full details of the entire series can be found in part 1 [1].

Proposed national transposition dates	
Date of latest announcement of this EN (doa):	3 months after ETSI publication
Date of latest publication of new National Standard or endorsement of this EN (dop/e):	6 months after doa
Date of withdrawal of any conflicting National Standard (dow):	18 months after doa

1 Scope

The present document, together with EN 301 489-1 [1], covers the assessment of CDMA 1x spread spectrum mobile and portable (UE) radio terminal equipment and associated ancillary equipment in respect of ElectroMagnetic Compatibility (EMC).

Technical specifications related to the antenna port of radio equipment and emission from the enclosure port of radio equipment are not included in the present document. Such technical specifications are found in the relevant product standards for the effective use of the radio spectrum.

The present document specifies the applicable test conditions, performance assessment and performance criteria of CDMA 1x spread spectrum mobile and portable (UE) radio terminal equipment and associated ancillary equipment.

Examples of mobile and portable radio equipment covered by the present document are given in annex A.

In case of differences (for instance concerning special conditions, definitions, abbreviations) between the present document and EN 301 489-1 [1], the provisions of the present document take precedence.

Base Station equipment (BS) operating within network infrastructure is outside the scope of the present document. However, the present document does cover mobile and portable equipment that is intended to be operated in a fixed location while connected to the AC mains (see clause 5.5).

The environment classification and the emission and immunity requirements used in the present document are as stated in EN 301 489-1 [1], except for any special conditions included in the present document.

2 References

The following documents contain provisions which, through reference in this text, constitute provisions of the present document.

- References are either specific (identified by date of publication and/or edition number or version number) or non-specific.
- For a specific reference, subsequent revisions do not apply.
- For a non-specific reference, the latest version applies.

Referenced documents which are not found to be publicly available in the expected location might be found at <http://docbox.etsi.org/Reference>.

- [1] ETSI EN 301 489-1 (V1.5.1): "Electromagnetic compatibility and Radio spectrum Matters (ERM); ElectroMagnetic Compatibility (EMC) standard for radio equipment and services; Part 1: Common technical requirements".
- [2] Directive 1999/5/EC of the European Parliament and of the Council of 9 March 1999 on radio equipment and telecommunications terminal equipment and the mutual recognition of their conformity (R&TTE Directive).
- [3] Council Directive 89/336/EEC of 3 May 1989 on the approximation of the laws of the Member States relating to electromagnetic compatibility (EMC Directive).
- [4] Directive 98/34/EC of the European Parliament and of the Council of 22 June 1998 laying down a procedure for the provision of information in the field of technical standards and regulations.
- [5] TIA-98-E: "Recommended Minimum Performance Standards for cdma2000[®] Spread Spectrum Mobile Stations".
- [6] TIA/EIA-126-D: "Mobile Station Loopback Service Options Standard".
- [7] ETSI ETR 027 (1991): "Radio Equipment and Systems (RES); Methods of measurement for private mobile radio equipment".

- [8] ITU-T Recommendation P.64: "Determination of sensitivity/frequency characteristics of local telephone systems".
- [9] ITU-T Recommendation P.76: "Determination of loudness ratings; fundamental principles", annex A.
- [10] ITU-R Recommendation SM.329-10: "Unwanted emissions in the spurious domain".
- [11] TIA/EIA/IS-2000 Series, Release A: "CDMA 2000[®] Series".

3 Definitions and abbreviations

3.1 Definitions

For the purposes of the present document, the terms and definitions given in EN 301 489-1 [1] and the following apply:

CDMA-PAMR: term used to denote a PAMR system, based on TIA/EIA/IS-2000 [11] Spreading Rate 1 specifications

CDMA 1x Spread Spectrum: term used to denote cdma2000 Spread Spectrum Systems and their evolution with spreading rate 1

data application ancillary: ancillary equipment which provides send and/or receive data access to services via the UE

forward CDMA Channel: CDMA channel from a base station to mobile stations

NOTE: The Forward CDMA Channel contains one or more code channels that are transmitted on a CDMA frequency assignment using a particular pilot PN offset.

Frame Error Rate (FER): Frame Error Rate of the forward traffic channel

NOTE: The value of frame error rate may be estimated by using service options 2, 9, 32, 54 or 55 (see clause 1.3 in TIA-98-E [5]).

idle mode: state of Mobile Station (MS) when switched on, but with no transmission

International Mobile Telecommunications-2000 (IMT-2000): third generation mobile systems which provide access, by means of one or more radio links, to a wide range of telecommunications services supported by the fixed telecommunication networks (e.g. PSTN, ISDN or IP), and to other services which are specific to mobile users

Mobile Station (MS): User Equipment (UE) entity capable of accessing a set of services via one or more radio interfaces

NOTE: This entity may be stationary or in motion within the radio service area while accessing the services, and may simultaneously serve one or more users.

Necessary Bandwidth: As defined in ITU-R Recommendation SM.329-10 [10].

traffic mode: state of Mobile Equipment (MS) when switched on and with a call established, using the radio configuration supported by the mobile station

NOTE: See clause 1.3 in TIA-98-E [5].

3.2 Abbreviations

For the purposes of the present document, the following abbreviations apply:

AC	Alternating Current
BS	Base Station
CDMA	Code Division Multiple Access
DC	Direct Current
EMC	ElectroMagnetic Compatibility
EUT	Equipment Under Test

FER	Frame Error Rate
FL	Forward Link from the BS to MS
IMT-2000	International Mobile Telecommunications
MRP	Mouth Reference Point (artificial head)
MS	Mobile Station
PAMR	Public Access Mobile Radio
PN	Pseudo-random Number
RC	Radio Configuration
RF	Radio Frequency
RL	Reverse Link from MS to BS
SPL	Sound Pressure Level
UE	User Equipment

4 Test conditions

For the purpose of the present document, the test conditions of EN 301 489-1 [1], clause 4, shall apply as appropriate. Further product related test conditions for digital cellular mobile and portable radio equipment are specified in the present document.

4.1 General

For emission and immunity tests, the test modulation, test arrangements, etc. as specified in the present document, clauses 4.1 to 4.5 shall apply.

Whenever the Equipment Under Test (EUT) is provided with a detachable antenna, the EUT shall be tested with the antenna fitted in a manner typical of normal intended use, unless specified otherwise.

4.2 Arrangements for test signals

The provisions of EN 301 489-1 [1], clause 4.2 shall apply with the following modifications.

The wanted RF signal nominal frequency shall be selected by setting the CDMA channel to an appropriate number.

A communication link shall be set up with a suitable base station simulator (hereafter called "the test system") according to the Radio Configuration (RC) supported by the mobile station TIA-98-E [5] using full data rate only. The test system shall be located outside of the test environment.

Where possible the test of the transmitter section and receiver section of the EUT may be carried out simultaneously to reduce test time.

Immunity tests on mobile and portable radio equipment (MS) shall be performed in two modes of operation:

- with a communication link established (traffic mode); and
- in idle mode.

When the EUT is required to be in the traffic mode, a call is set up using Loopback Service Option (see TIA/EIA-126-D [6]) according to the radio configuration supported by the mobile station (see clause 1.3 in TIA-98-E [5]), and the following conditions shall be met:

- the EUT shall be commanded to operate at maximum transmit power;
- the "variable Data Rate Transmission" shall be disabled;
- the MS shall be set for maximum data transmission rate.

When the EUT is required to be in the idle mode, then the following conditions shall be met:

- enable the receiver for CDMA-only mode;

- the test system shall simulate a Base Station with the Paging Channel or the Quick Paging Channel or Forward Common Control Channel/Broadcast Control Channel on one carrier. The MS shall be synchronized and be able to respond to paging messages. The MS shall not initiate a call (mobile station originated call), re-registration, or message transmission.

Adequate measures shall be taken to avoid the effect of the immunity test RF signal on the measuring equipment.

4.2.1 Arrangements for test signals at the input of transmitters

The provisions of EN 301 489-1 [1], clause 4.2.1 shall apply.

4.2.2 Arrangements for test signals at the output of transmitters

The provisions of EN 301 489-1 [1], clause 4.2.2 shall apply with the following modifications.

Where the equipment incorporates an external 50 Ω RF antenna connector that is normally connected via a coaxial cable, then the wanted signal to establish a communication link shall be delivered from that connector by a coaxial cable.

Where the equipment incorporates an external 50 Ω RF antenna connector, but this port is not normally connected via a coaxial cable, and where the equipment does not incorporate an external 50 Ω RF connector (integral antenna equipment), then the wanted signal, to establish a communication link, shall be delivered from the equipment to an antenna located within the test environment.

4.2.3 Arrangements for test signals at the input of receivers

The provisions of EN 301 489-1 [1], clause 4.2.3 shall apply with the following modifications.

Where the equipment incorporates an external 50 Ω RF antenna connector that is normally connected via a coaxial cable, then the wanted signal to establish a communication link shall be delivered to that connector by a coaxial cable.

Where the equipment incorporates an external 50 Ω RF antenna connector, but this port is not normally connected via a coaxial cable, and where the equipment does not incorporate an external 50 Ω RF connector (integral antenna equipment), then the wanted signal, to establish a communication link, shall be presented to the equipment from an antenna located within the test environment.

For immunity testing the wanted RF signal level at the input of the EUT shall be at least 40 dB above the reference sensitivity level to provide a stable communication link.

For emission testing the wanted RF signal level at the input of the measuring receiver shall be no more than 15 dB above the reference sensitivity level, to ensure that it operates within its dynamic range.

The reference sensitivity level is defined in TIA-98-E [5].

The input signal levels used during the tests shall be recorded in the test report.

4.2.4 Arrangements for test signals at the output of receivers

The provisions of EN 301 489-1 [1], clause 4.2.4 shall apply with the following modification.

The specific arrangement for test signals at the output of receivers are found in annex B for receivers operating with analogue speech output (voice), and in annex C for receivers operating with non-speech output (data).

4.3 Exclusion bands

4.3.1 Transmitter exclusion band

The transmitter frequency bands including in band emissions and out of band emissions are covered by the RF spectral mask specification and need no further consideration.

For the purpose of EMC specifications the transmitter exclusion band shall be the carrier centre frequency $\pm (2,5 \times \text{Necessary Bandwidth})$.

4.3.2 Receiver exclusion band

The exclusion band for receivers and receiver sections of transceivers is the band of frequencies over which no immunity tests with radiated RF are made.

The receiver exclusion band for terminals extends from the lower frequency of the relevant receiver band minus 5 % to the upper frequency of the relevant receiver band plus 5 %.

4.4 Narrow band responses on receivers

Responses on receivers or duplex transceivers occurring during immunity tests at discrete frequencies, which are narrow band responses (spurious responses), are identified by the following method:

- if during an immunity test the quantity being monitored goes outside the specified tolerances (see clause 6.2), it is necessary to establish whether the deviation is due to an unwanted effect on the receiver of the MS or on the test system (narrow band response) or to a wideband (EMC) phenomenon. Therefore, the test shall be repeated with the MS channel frequency increased and then decreased to the first adjacent RF CDMA channel;
- if the deviation in either or both frequency offset cases disappears, the response is considered as a narrow band response;
- if the deviation does not disappear, the procedure is repeated with the MS channel frequency increased and then decreased to the second adjacent RF CDMA channels centre frequency;
- if the deviation still does not disappear with the increased and/or decreased MS channel frequency, the phenomenon is considered wide band and therefore an EMC problem and the equipment fails the test.

For immunity tests, narrow band responses shall be disregarded.

4.5 Normal test modulation

For immunity tests in voice call mode, the overall audio reverse link and forward link performance of the radio equipment shall be calibrated before the start of the tests. The calibration procedure is presented in clause B.1.

Immunity tests in voice call mode shall be performed without the application of any external modulation input signal.

For immunity tests in data transfer mode, the tests shall be performed with the application of an appropriate external modulation input signal such that the performance of the data transmission can be monitored. The performance assessment of the data transmission procedure is presented in annex C.

5 Performance assessment

5.1 General

The provisions of EN 301 489-1 [1], clause 5.1 shall apply with the following modification.

The information about the bandwidth of the IF filter immediately preceding the demodulator set out in EN 301 489-1 [1], clause 5.1 is not applicable to radio equipment in the scope of the present document.

5.2 Equipment which can provide a continuous communication link

The provisions of EN 301 489-1 [1], clause 5.2 shall apply.

5.3 Equipment which does not provide a continuous communication link

The provisions of EN 301 489-1 [1], clause 5.3 shall apply.

5.4 Ancillary equipment

The provisions of EN 301 489-1 [1], clause 5.4 shall apply with the following modification.

Ancillary equipment shall be tested with it connected to an MS in which case compliance shall be demonstrated for the combination of ancillary and radio equipment to the appropriate clauses of the present document.

5.5 Equipment classification

The provisions of EN 301 489-1 [1], clause 5.5 shall apply.

6 Performance criteria

6.1 General

The equipment shall meet the performance criteria specified in this clause, clauses 6.2 and 6.3, as appropriate.

The maintenance of a communications link shall be assessed using an indicator, which may be part of the test system, or of the EUT.

If an equipment is of a specialized nature, that the performance criteria described in the following clauses are not appropriate, then the manufacturer shall declare, for inclusion in the test report, his own specification for an acceptable level of performance or degradation of performance during and/or after testing, as required by the present document.

Immunity tests shall be performed with the EUT set into traffic mode of operation. For transmitters, the tests shall also be performed in idle mode and the transmitter shall not unintentionally operate.

6.2 Performance criteria for continuous phenomena

A communication link shall be established at the start of the test, and maintained during the test, see clauses 4.1 and 4.2.

For transmission of digital data (in data transfer mode of operation), the performance criteria shall be the following:

- The Frame Error Rate (FER) using 9 600 bit/s only data rate shall not exceed 0,5 % with 95 % confidence (see clause 6.6 in TIA-98-E [5]). However, in the case of PAMR mobile terminals the Frame Error Rate (FER) using 9 600 bit/s only data rate shall not exceed 2,0 % with 95 % confidence (see clause 6.6 in TIA-98-E [5]).

For transmission of analogue speech or audio signals (in speech mode of operation), the performance criteria is applicable to the Reverse Link (RL) and Forward Link (FL) audio outputs and these shall be at least 35 dB less than the reference levels recorded during the calibration procedure. This measurement is performed using an audio band pass filter of 200 Hz width, centred on 1 kHz (see annex B).

NOTE: If a high level background audio noise is present during the immunity tests, then the audio band pass filter may be reduced down to a minimum of 40 Hz bandwidth with a centre frequency of 1 kHz.

At the conclusion of the test, the EUT shall operate as intended with no loss of user control functions or stored data, and the communication link shall have been maintained.

6.3 Performance criteria for transient phenomena

A communications link shall be established at the start of the test, see clauses 4.1 and 4.2.

At the conclusion of each exposure it shall be verified that the communications link has been maintained. At the conclusion of the total test comprising the series of individual exposures, the EUT shall operate as intended with no loss of user control functions or stored data, as declared by the manufacturer, and the communications link shall have been maintained.

7 Applicability overview tables

7.1 Emission

7.1.1 General

EN 301 489-1 [1], table 2 contains the applicability of EMC emission measurements to the relevant ports of radio and/or associated ancillary equipment.

7.1.2 Special conditions

No special conditions shall apply to UE in the scope of the present document.

7.2 Immunity

7.2.1 General

EN 301 489-1 [1], table 3 contains the applicability of EMC immunity measurements to the relevant ports of radio and/or associated ancillary equipment.

7.2.2 Special conditions

The following special conditions set out in table 1, relate to the immunity test methods used in EN 301 489-1 [1], clause 9.

Table 1: Special conditions for EMC immunity tests

Reference to clauses in EN 301 489-1 [1]	Special product-related conditions, additional to or modifying the test conditions in EN 301 489-1 [1], clause 9
9.2 Radio frequency electromagnetic field 9.2.2 Test method	When using the max hold detector method (see annex B) at each test frequency step initially an unmodulated test signal shall be applied. Then the test modulation shall be applied.
9.5 Radio frequency, common mode; 9.5.2 Test method	There is no exclusion band for the equipment in the scope of the present document. When using the max hold detector method (see annex B) at each test frequency step initially an unmodulated test signal shall be applied. Then the test modulation shall be applied. The procedure used for identifying narrowband responses does not apply to conducted immunity tests in the frequency range 150 kHz to 80 MHz (see clause 4.4).
9.6 Transients and surges in the vehicular environment; 9.6.2 Test method	Mobile radio and ancillary equipment in the scope of the present document are not subject to immunity tests with pulse no 7. For radio equipment designed to operate at 12 V DC and 24 V DC supplies it is sufficient to apply pulse 4 for 12V DC systems and perform the 24 V DC tests set out in clause 9.6.2.2 of EN 301 489-1 [1].
9.6 Transients and surges in the vehicular environment; 9.6.3 Performance criteria	During tests with pulses 3a and 3b, the performance criteria TT shall apply, see clause 6.3.

Annex A (informative): Examples of mobile and portable radio and ancillary equipment within the scope of the present document

The present document covers types of mobile and/or portable equipment using CDMA 1x spread spectrum technology as set out below.

A.1 Mobile and portable radio equipment, and ancillary equipment for IMT-2000 CDMA Multi-carrier Systems

The present document applies to IMT-2000 CDMA Multi-carrier systems digital cellular mobile and portable radio equipment. Definitions for mobile and portable radio and associated ancillary equipment within the scope of the present document are found in the following functional radio specification:

- TIA-98-E: "Recommended Minimum Performance standards for cdma2000[®] Spread Spectrum Mobile stations" [5].

A.2 Mobile and portable radio equipment, and ancillary equipment for CDMA-PAMR Systems

The present document applies to CDMA PAMR systems mobile and portable radio equipment operating in one or more of the band classes defined in TIA-98-E [5] depending upon national regulations. Definitions for mobile and portable radio and associated ancillary equipment within the scope of the present document are found in the following functional radio specification:

- TIA-98-E: "Recommended Minimum Performance standards for cdma2000[®] Spread Spectrum Mobile stations" [5].

Annex B (normative): Performance assessment voice call. Audio break through

B.1 Calibration of audio levels

For the portable the audio calibration is performed as follows:

Set the EUT volume to provide the nominal audio level if specified by the manufacturer. If no such level is specified, the centre volume step shall be used.

Prior to the test sequence, the reference level of the speech output signal on both the forward link and reverse link shall be recorded on the test instrumentation, as shown in figure B.1. The reference level shall be equivalent to the SPL of 0 dBPa at 1 kHz at the input of the acoustical coupler described in ETR 027 [7], for the forward link, and -5 dBPa at 1 kHz at the mouth reference point (MRP) defined in ITU-T Recommendation P.64 [8] for the reverse link.

NOTE 1: The MRP is defined with respect to an artificial head defined in ITU-T Recommendation P.76 [9]. The handset shall be mounted on the artificial head such that the ear piece is centred at the artificial ear.

NOTE 2: If the equipment does not include acoustical transducers (e.g. a microphone or loudspeaker) the manufacturer shall specify the equivalent electrical reference levels.

The voice processor may often apply noise and echo cancellation algorithms, which attempt to eliminate or reduce steady state audio signals as e.g. the 1 kHz calibration signals. These algorithms may be disabled during the calibration procedure. Specialized test software may be required. If the algorithms can not be disabled then the reference level shall be measured using a max-hold detection on the audio level meter in order to determine the level before the noise and echo cancellation algorithms become effective.

In handsfree applications an external loudspeaker is used. The SPL from the external loudspeaker is normally much higher than from the earpiece of the portable in order to overcome a high ambient noise level. The forward link reference level shall be increased in order to compensate for the difference. Alternatively, the distance between the loudspeaker and the measuring microphone shall be adjusted during the measurement procedure in accordance with the manufacturers specification. It is important that the dynamic range of the test instrumentation is not exceeded.

Normally no corrections are made to the reverse link reference level. In case it is not possible to perform the above calibration (e.g. a PC card with headset) the manufacturer shall specify the distance between the MRP and the microphone.

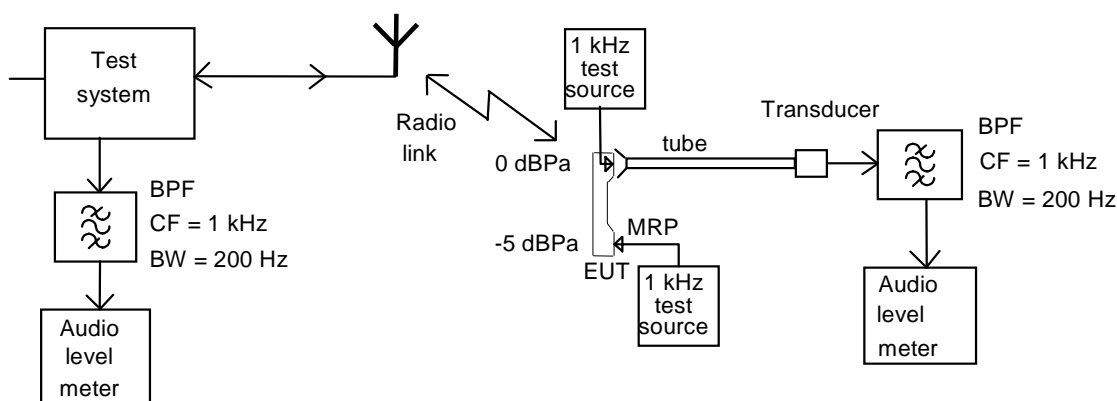

MRP = Mouth Reference Point

NOTE: The EUT is in position during calibration of the reverse link, but not during calibration of the forward link where the EUT is replaced by the 1 kHz test audio source. During calibration of the reverse link the mouthpiece shall be placed with respect to the MRP in a way representing intended use.

Figure B.1: Audio breakthrough measurement, calibration set-up for portable equipment

B.2 Measurement of audio levels

When the audio levels are measured during testing the EUT software shall be configured for voice applications. If the algorithms for noise and echo cancellation are not disabled, then the level shall be measured using a max-hold detection on the audio level meter in order to determine the level before the noise and echo cancellation algorithms become effective.

The level of the output signal from the forward link speech channel of the EUT at the mobile or portable's ear piece shall be assessed by measuring the Sound Pressure Level (SPL) as shown in figure B.2. When an external loudspeaker is used the acoustical coupler shall be fixed to the loudspeaker in the position used during the calibration. The level of the decoded output signal from the reverse link speech channel of the EUT at the analogue output of the test system shall be measured. Pick up of extraneous background noise by the microphone of the EUT shall be minimized.

NOTE: If the equipment is designed for use with external transducers, they shall be included in the test configuration. If the equipment does not include acoustical transducers the line voltage developed across specified termination impedance may be measured.

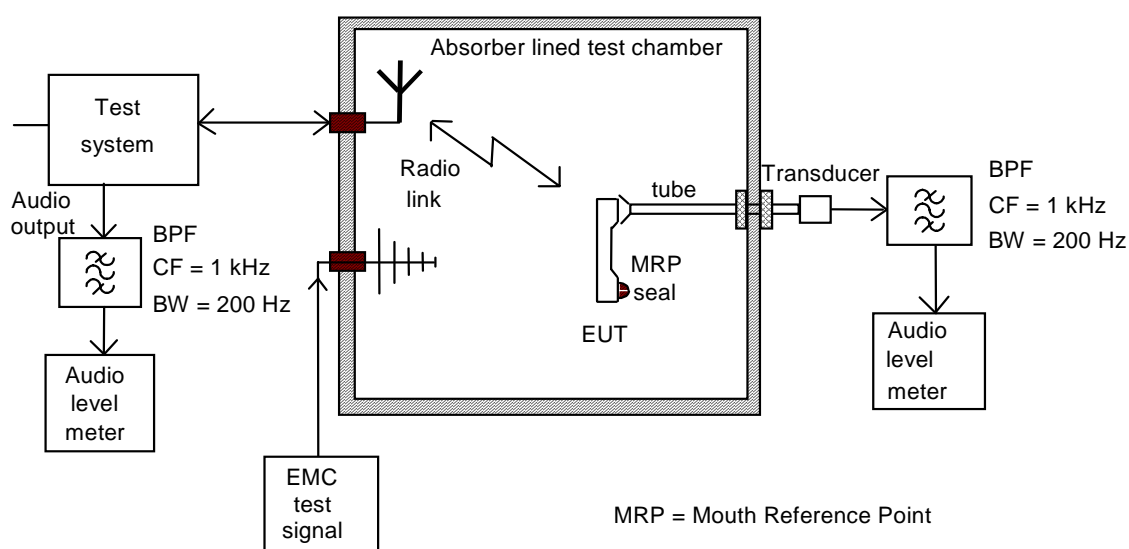

Figure B.2: Audio breakthrough measurement, test set-up for portable equipment

Annex C (normative): Performance assessment of data transfer call. Error Rates

C.1 Calibration of data transfer

For the EUT, calibration of the data transfer may be performed by assessing the Frame Error Rate (FER), or End-User data error ratio before applying the RF immunity test signal (defined in EN 301 489-1 [1], clauses 9.2 and 9.5).

C.2 Derivation of Error Rates

The manufacturer shall provide the method for calculating the Frame Error Ratio. Known data patterns shall be transferred bi-directionally from end-to-end (the whole of the RL and FL will be exercised). Performance assessment shall be made at each frequency step. Comparison between transmitted known data and received data shall result in the Frame Error Rate (FER).

The data patterns used should be of sufficient length to give valid results and should be equivalent to the used channel bit rate.

Possible data patterns for assessing the Error Ratio are FER and User Data. Detailed description of FER can be found from TIA-98-E [5].

End-User Data may be used where FER measurements are not appropriate, and is a manufacturer's decision (see below).

NOTE: For example, in the cases when the EUT consists of MS with data application ancillary and the data application ancillary itself does not support a loopback function that can be applied for the assessment of FER, as specified in TIA-98-E [5]. This would lead into a situation where the data application ancillary is not exercised, i.e. the data transfer loop is not end-to-end.

The characteristics of the End-User Data used for testing (format, size, typical data throughput rate, additional error corrections etc.) and the necessary test equipment shall be delivered to enable the assessment of the EUT.

Following formula may apply to End-User Data:

$$\text{FrameErrorRate} = \left(\frac{\text{erroneous frames}}{\text{total number of frames received}} \times 100 \right) = n \%$$

C.3 EUT without data application ancillary

Data monitoring Devices are here considered as part of the Test System. Arrangements should be made by the manufacturer, if needed, to couple the Data monitoring Device by a method which does not affect the radiated electromagnetic field (e.g. ultrasonic or optical).

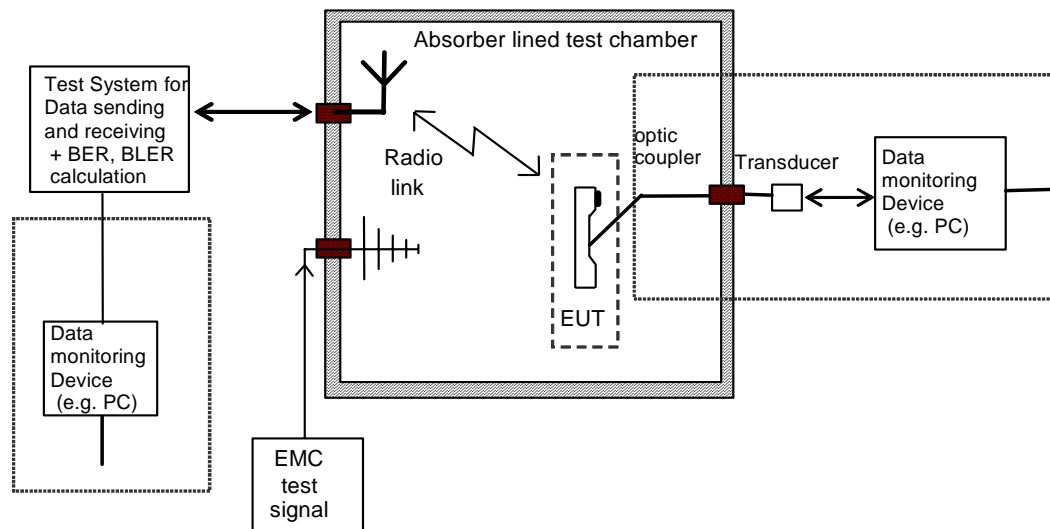

Figure C.1: Error Rate assessment, test set-up for EUT without data application ancillary

C.4 EUT with data application ancillary

The Data monitoring Device is here considered as a part of the Test System. The Data application ancillary should be part of the data transfer (RL and FL) loop and is included in the EUT configuration.

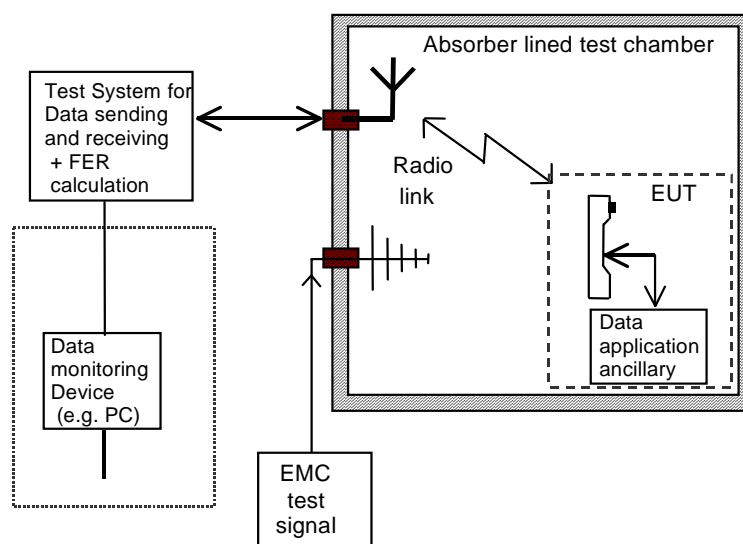

Figure C.2: Error Rate assessment, test set-up for EUT with data application ancillary

Annex D (informative): Bibliography

3GPP2 C.S0002-A: "Physical Layer Standard for cdma2000 Spread Spectrum Systems".

3GPP2 C.S0002-B: "Physical Layer Standard for cdma2000 Spread Spectrum Systems Release B".

3GPP2 C.S0002-C: "Physical Layer Standard for cdma2000 Spread Spectrum Systems Release C".

Annex E (informative): The EN title in the official languages

Language	EN title
Czech	Otázky elektromagnetické kompatibility a rádiového spektra; Normy elektromagnetické kompatibility pro rádiová zařízení a služby; Částka 25: Zvláštní podmínky pro CDMA 1x Rozprostřené Spektrum mobilní stanice a jejich příslušenství.
Danish	Elektromagnetisk kompatibilitet og radiospektrum-anliggender (ERM); Elektromagnetisk kompatibilitet (EMC) for radioudstyr og tjenester; Del 25: Særlige krav til CDMA 1x Spread Spectrum mobilstationer og hjælpeudstyr.
Dutch	Elektromagnetische compatibiliteit en radiospectrumzaken (ERM); Elektromagnetische compatibiliteitsnorm (EMC) voor radioapparatuur en radiodiensten; Deel 25: Specifieke condities voor CDMA 1X Spread Spectrum mobiele stations en hulpparaatuur.
English	Electromagnetic compatibility and radio spectrum matters (ERM); Electromagnetic compatibility (EMC) standard for radio equipment and services; Part 25: Specific conditions for CDMA 1x Spread Spectrum Mobile Stations and ancillary equipment.
Estonian	Elektromagnetilise ühilduvuse ja raadiospektri küsimused (ERM); Raadioseadmete ja teenuste elektromagnetilise ühilduvuse (EMC) standard; Osa 25: Hajaspektriga CDMA 1x liikuvate raadiojaamade ja lisaseadmete eritingimused.
Finnish	Sähkömagneettinen yhteensopivuus ja radiospektriasiat (ERM); sähkömagneettinen yhteensopivuusstandardi (EMC) radiolaitteille ja järjestelmille; Osa 25: Erytisehdot CDMA 1x -hajaspektritekniikkaa käyttäville ajoneuvoon asennettaville tai kannettavilla päätelaitteille ja niiden oheislaitteille.
French	Compatibilité électromagnétique et spectre radioélectrique (ERM); Norme de compatibilité électromagnétique (CEM) pour équipement de communication radio et services; Partie 25: conditions spécifiques pour stations mobiles et équipements auxiliaires utilisant le CDMA 1x à étalement de spectre.
German	Elektromagnetische Verträglichkeit und Funkspektrumsangelegenheiten (ERM); Elektromagnetische Verträglichkeit (EMV) für Funkgeräte und Funkdienste; Teil 25: Spezielle Anforderungen für CDMA 1x Spread Spectrum Mobilstationen und Zusatzeinrichtungen.
Greek	Ηλεκτρομαγνητική συμβατότητα και θέματα ραδιοφάσματος (ERM); Πρότυπο ηλεκτρομαγνητικής συμβατότητας (EMC) που αφορά ραδιοεξοπλισμό και ραδιοπηρεσίες; Μέρος 25: Ειδικές συνθήκες για CDMA 1x κινητούς σταθμούς ευρέως φάσματος, αναμεταδότες και βοηθητικό εξοπλισμό.
Hungarian	Elektromágneses kompatibilitási és rádió spektrum ügyek; Elektromágneses kompatibilitási szabvány rádiókészülékekhez és szolgáltatásokhoz; Rész 25: Speciális feltételek CDMA 1x Szórt Spektrumú mobilállomásokhoz és kiegészítő berendezésekhez.
Italian	Compatibilità elettromagnetica e Questioni relative allo spettro delle radiofrequenze (ERM); Norma di Compatibilità elettromagnetica (EMC) per apparecchiature e servizi radio; Parte 25 Condizioni specifiche per stazioni mobili e apparecchiature ausiliarie per CDMA 1x Spread Spectrum.
Latvian	
Lithuanian	
Maltese	
Polish	Kompatybilność elektromagnetyczna i sprawy widma radiowego (ERM); Standard kompatybilności elektromagnetycznej (EMC) dla sprzętu radiowego i usług; Część 25; Warunki szczególne dla systemów z wielodostepem kodowanym 1x widma rozproszonego Stacje ruchome i sprzęt pomocniczy.
Portuguese	Assuntos de espectro radioelétrico e compatibilidade electromagnética (ERM); norma de compatibilidade electromagnética (EMC) para equipamento de rádio e serviços; parte 25: Condições específicas para as estações móveis e equipamento auxiliar do CDMA 1x Spread Spectrum.
Slovak	Otázky elektromagnetickej kompatibility a rádiového spektra, Normy elektromagnetickej kompatibility pre rádiové zariadenia a služby, Časť 25: Špecifické podmienky pre CDMA 1x rozprestrené spektrum mobilné stanice a ich príslušenstvo.
Slovenian	
Spanish	Compatibilidad electromagnética y cuestiones de espectro de radiofrecuencia (ERM); compatibilidad electromagnética (EMC) estándar para equipos radio y servicios; parte 25: Condiciones específicas para estaciones móviles y equipos auxiliares de espectro ensanchado con CDMA 1x.
Swedish	Elektromagnetisk kompatibilitet och radiospektrumfrågor (ERM); Elektromagnetisk kompatibilitetsstandard (EMC) för radioutrustning och tjänster; Del 25: Specifika villkor för CDMA 1x Spread Spectrum mobila stationer och tillhörande utrustning

History

Document history		
V2.0.0	September 2001	Publication
V2.2.1	May 2003	Publication
V2.3.2	July 2004	Public Enquiry PE 20041105: 2004-07-07 to 2004-11-05