

Draft **ETSI EN 301 489-25** V1.1.1 (2000-12)

---

*Candidate Harmonized European Standard (Telecommunications series)*

**Electromagnetic compatibility  
and Radio spectrum Matters (ERM);  
ElectroMagnetic Compatibility (EMC) standard for  
radio equipment and services;  
Part 25: Specific conditions for IMT-2000  
CDMA Multi-carrier Mobile Stations and  
ancillary equipment**

---



---

**Reference**

REN/ERM-EMC-228-1

---

**Keywords**EMC, IMT-2000, cdma2000, radio, regulation,  
terminal**ETSI**

---

650 Route des Lucioles  
F-06921 Sophia Antipolis Cedex - FRANCE

Tel.: +33 4 92 94 42 00 Fax: +33 4 93 65 47 16

Siret N° 348 623 562 00017 - NAF 742 C  
Association à but non lucratif enregistrée à la  
Sous-Préfecture de Grasse (06) N° 7803/88

---

**Important notice**

Individual copies of the present document can be downloaded from:

<http://www.etsi.org>

The present document may be made available in more than one electronic version or in print. In any case of existing or perceived difference in contents between such versions, the reference version is the Portable Document Format (PDF). In case of dispute, the reference shall be the printing on ETSI printers of the PDF version kept on a specific network drive within ETSI Secretariat.

Users of the present document should be aware that the document may be subject to revision or change of status. Information on the current status of this and other ETSI documents is available at <http://www.etsi.org/tb/status/>

If you find errors in the present document, send your comment to:  
editor@etsi.fr

---

**Copyright Notification**

No part may be reproduced except as authorized by written permission.  
The copyright and the foregoing restriction extend to reproduction in all media.

© European Telecommunications Standards Institute 2000.  
All rights reserved.

---

# Contents

Intellectual Property Rights .....	5
Foreword .....	5
1 Scope.....	7
2 References .....	7
3 Definitions and abbreviations .....	8
3.1 Definitions .....	8
3.2 Abbreviations.....	8
4 Test conditions .....	9
4.1 General .....	9
4.2 Arrangements for test signals.....	9
4.2.1 Arrangements for test signals at the input of transmitters.....	9
4.2.2 Arrangements for test signals at the output of transmitters.....	9
4.2.3 Arrangements for test signals at the input of receivers.....	10
4.2.4 Arrangements for test signals at the output of receivers.....	10
4.3 Exclusion bands .....	10
4.4 Narrow band responses on receivers .....	10
4.5 Normal test modulation .....	11
5 Performance assessment .....	11
5.1 General .....	11
5.2 Equipment which can provide a continuous communication link.....	11
5.3 Equipment which does not provide a continuous communication link.....	11
5.4 Ancillary equipment.....	11
5.5 Equipment classification.....	11
6 Performance criteria.....	11
6.1 General .....	11
6.2 Performance criteria for continuous phenomena.....	12
6.3 Performance criteria for transient phenomena.....	12
7 Applicability overview tables.....	12
7.1 Emission .....	12
7.1.1 General.....	12
7.1.2 Special conditions.....	12
7.2 Immunity .....	13
7.2.1 General.....	13
7.2.2 Special conditions.....	13

<b>Annex A (informative):</b>	<b>Examples of mobile and portable radio and ancillary equipment for digital cellular radio telecommunications systems within the scope of the present document.....</b>	<b>14</b>
A.1	Mobile and portable radio equipment, and ancillary equipment for IMT-2000 CDMA Multi-carrier Systems .....	14
<b>Annex B (normative):</b>	<b>Performance assessment voice call. Audio break through.....</b>	<b>15</b>
B.1	Calibration of audio levels .....	15
B.2	Measurement of audio levels.....	16
<b>Annex C (normative):</b>	<b>Performance assessment of data transfer call. Error Rates .....</b>	<b>17</b>
C.1	Calibration of data transfer.....	17
C.2	Derivation of Error Rates .....	17
C.3	EUT without data application ancillary .....	17
C.4	EUT with data application ancillary .....	18
History	.....	19

---

# Intellectual Property Rights

IPRs essential or potentially essential to the present document may have been declared to ETSI. The information pertaining to these essential IPRs, if any, is publicly available for **ETSI members and non-members**, and can be found in ETSI SR 000 314: "*Intellectual Property Rights (IPRs); Essential, or potentially Essential, IPRs notified to ETSI in respect of ETSI standards*", which is available from the ETSI Secretariat. Latest updates are available on the ETSI Web server (<http://www.etsi.org/ipr>).

Pursuant to the ETSI IPR Policy, no investigation, including IPR searches, has been carried out by ETSI. No guarantee can be given as to the existence of other IPRs not referenced in ETSI SR 000 314 (or the updates on the ETSI Web server) which are, or may be, or may become, essential to the present document.

---

## Foreword

This Candidate Harmonized European Standard (Telecommunications series) has been produced by ETSI Technical Committee Electromagnetic compatibility and Radio spectrum Matters (ERM), and is now submitted for the Public Enquiry phase of the ETSI standards Two-step Approval Procedure.

The present document has been produced by ETSI in response to a mandate from the European Commission issued under the Council Directive 98/34/EC [4] (as amended) laying down a procedure for the provision of information in the field of technical standards and regulation.

The present document is intended to become a Harmonized EMC Standard, the reference of which will be published in the Official Journal of the European Communities referencing the Council Directive on the approximation of the laws of the Member States relating to electromagnetic compatibility (the "EMC Directive" 89/336/EEC [3] as amended), and the Council Directive on the approximation of the laws of the Member States relating to radio equipment and telecommunications terminal equipment and the mutual recognition of their conformity (the "R&TTE Directive" 1999/5/EC [2]).

The present document is part 25 of a multipart deliverable, covering the ElectroMagnetic Compatibility (EMC) standard, as identified below:

- Part 1: "Common technical requirements";
- Part 2: "Specific conditions for radio paging equipment";
- Part 3: "Specific conditions for Short-Range Devices (SRD) operating on frequencies between 9 kHz and 40 GHz";
- Part 4: "Specific conditions for fixed radio links and ancillary equipment and services";
- Part 5: "Specific conditions for Private land Mobile Radio (PMR) and ancillary equipment (speech and non-speech)";
- Part 6: "Specific conditions for Digital Enhanced Cordless Telecommunications (DECT) equipment";
- Part 7: "Specific conditions for mobile and portable radio and ancillary equipment of digital cellular radio telecommunications systems (GSM and DCS)";
- Part 8: "Specific conditions for GSM base stations";
- Part 9: "Specific conditions for wireless microphones and similar Radio Frequency (RF) audio link equipment";
- Part 10: "Specific conditions for First (CT1 and CT1+) and Second Generation Cordless Telephone (CT2) equipment";
- Part 11: "Specific conditions for terrestrial broadcasting transmitters";
- Part 12: "Specific conditions for Very Small Aperture Terminal, Satellite Interactive Earth Stations operated in the frequency ranges between 4 GHz and 30 GHz in the Fixed Satellite Service (FSS)";
- Part 13: "Specific conditions for Citizens' Band (CB) radio and ancillary equipment (speech and non-speech)";

- Part 15: "Specific conditions for commercially available amateur radio equipment";
- Part 16: "Specific conditions for analogue cellular radio communications equipment, mobile and portable";
- Part 17: "Specific conditions for Wideband data and HIPERLAN equipment";
- Part 18: "Specific conditions for Terrestrial Trunked Radio (TETRA) equipment";
- Part 19: "Specific conditions for Receive Only Mobile Earth Stations (ROMES) operating in the 1,5 GHz band providing data communications";
- Part 20: "Specific conditions for Mobile Earth Stations (MES) used in the Mobile Satellite Services (MSS)";
- Part 22: "Specific conditions for ground based VHF aeronautical mobile and fixed radio equipment";
- Part 23: "Specific conditions for IMT-2000 CDMA Direct Spread (UTRA) for Base Station (BS) radio and ancillary equipment";
- Part 24: "Specific conditions for IMT-2000 CDMA Direct Spread (UTRA) for Mobile and portable (UE) radio and ancillary equipment";
- Part 25: "Specific conditions for IMT-2000 CDMA Multi-carrier Mobile Stations and ancillary equipment";**
- Part 26: "Specific conditions for IMT-2000 CDMA Multi-carrier Base Stations and ancillary equipment".

<b>Proposed national transposition dates</b>	
Date of latest announcement of this EN (doa):	3 months after ETSI publication
Date of latest publication of new National Standard or endorsement of this EN (dop/e):	6 months after doa
Date of withdrawal of any conflicting National Standard (dow):	18 months after doa

---

# 1 Scope

The present document, together with EN 301 489-1 [1], covers the assessment of "3rd Generation" digital cellular (IMT-2000 CDMA Multi-carrier) mobile and portable (UE) radio terminal equipment and associated ancillary equipment in respect of ElectroMagnetic Compatibility (EMC).

Technical specifications related to the antenna port of radio equipment and emission from the enclosure port of radio equipment are not included in the present document. Such technical specifications are found in the relevant product standards for the effective use of the radio spectrum.

The present document specifies the applicable test conditions, performance assessment and performance criteria of "3rd Generation" digital cellular (IMT-2000 CDMA Multi-carrier) mobile and portable (UE) radio terminal equipment and associated ancillary equipment.

Examples of digital cellular mobile and portable radio equipment covered by the present document are given in annex A.

In case of differences (for instance concerning special conditions, definitions, abbreviations) between the present document and EN 301 489-1 [1], the provisions of the present document take precedence.

Base station equipment (BS) operating within network infrastructure is outside the scope of the present document. However, the present document does cover mobile and portable equipment that is intended to be operated in a fixed location while connected to the AC mains (see clause 5.5).

The environment classification and the emission and immunity requirements used in the present document are as stated in EN 301 489-1 [1], except for any special conditions included in the present document.

---

# 2 References

The following documents contain provisions which, through reference in this text, constitute provisions of the present document.

- References are either specific (identified by date of publication and/or edition number or version number) or non-specific.
- For a specific reference, subsequent revisions do not apply.
- For a non-specific reference, the latest version applies.

- [1] ETSI EN 301 489-1 (V1.2.1, 2000): "Electromagnetic compatibility and Radio spectrum Matters (ERM); ElectroMagnetic Compatibility (EMC) standard for radio equipment and services; Part 1: Common technical requirements".
- [2] Directive 1999/5/EC of the European Parliament and of the Council of 9 March 1999 on radio equipment and telecommunications terminal equipment and the mutual recognition of their conformity.
- [3] Council Directive 89/336/EEC of 3 May 1989 on the approximation of the laws of the Member States relating to electromagnetic compatibility.
- [4] Directive 98/34/EC of the European Parliament and of the Council of 22 June 1998 laying down a procedure for the provision of information in the field of technical standards and regulations.
- [5] 3GPP2 C.S0011-A (2000): "Recommended Minimum Performance Standards for cdma2000 Spread Spectrum Mobile Stations".
- [6] 3GPP2 C.S0013-A (2000): "Loopback Service Options (LSO) for cdma2000 Spread Spectrum Systems".
- [7] ETSI ETR 027 (1991): "Radio Equipment and Systems (RES); Methods of measurement for private mobile radio equipment".

- [8] ITU-T Recommendation P.64: "Determination of sensitivity/frequency characteristics of local telephone systems".
- [9] ITU-T Recommendation P.76: "Determination of loudness ratings; fundamental principles, annex A".
- [10] 3GPP2 C.S0002-A (2000-06): "Mobile Station-Base Station - Compatibility Standard for Spread Spectrum Systems".

---

## 3 Definitions and abbreviations

### 3.1 Definitions

For the purposes of the present document, the terms and definitions given in EN 301 489-1 [1], clause 3 and the following apply:

**data application ancillary:** ancillary equipment which provides send and/or receive data access to IMT-2000 services via the UE

**Forward CDMA Channel:** CDMA channel from a base station to mobile stations. The Forward CDMA Channel contains one or more code channels that are transmitted on a CDMA frequency assignment using a particular pilot PN offset

**Frame Error Rate (FER):** frame error rate of the forward traffic channel. The value of frame error rate may be estimated by using service option 2, 9, 32, 54, or 55 (see clause 1.3 in 3GPP2 C.S0011-A [5])

**idle mode:** state of Mobile Station (MS) when switched on, but with no transmission

**International Mobile Telecommunications-2000 (IMT-2000):** third generation mobile systems which provide access, by means of one or more radio links, to a wide range of telecommunications services supported by the fixed telecommunication networks (e.g. PSTN, ISDN, or IP), and to other services which are specific to mobile users

**Mobile Station (MS):** user equipment (UE) entity capable of accessing a set of IMT-2000 services via one or more radio interfaces. This entity may be stationary or in motion within the IMT-2000 radio service area while accessing the IMT-2000 services, and may simultaneously serve one or more users

**Traffic mode:** state of Mobile Equipment (MS) when switched on and with a call established, using the radio configuration supported by the mobile station (see clause 1.3 in 3GPP2 C.S0011-A [5])

### 3.2 Abbreviations

For the purposes of the present document, the following abbreviations apply:

AC	Alternating Current
BS	Base Station
CDMA	Code Division Multiple Access
DC	Direct Current
EMC	Electromagnetic Compatibility
ESD	ElectroStatic Discharge
EUT	Equipment Under Test (UE or UE with ancillaries)
FER	Frame Error Rate
FL	Forward link from the BS to MS
IMT-2000	International Mobile Telecommunications 2000MRP Mouth Reference Point (artificial head)
MS	Mobile Station
RC	Radio Configuration
RF	Radio Frequency
RL	Reverse Link from MS to BS
PN	Pseudo-random number
SPL	Sound Pressure Level
UE	User Equipment



---

## 4 Test conditions

For the purpose of the present document, the test conditions of EN 301 489-1 [1], clause 4, shall apply as appropriate. Further product related test conditions for digital cellular mobile and portable radio equipment are specified in the present document.

### 4.1 General

For emission and immunity tests, the test modulation, test arrangements, etc., as specified in the present document, clauses 4.1 to 4.5 shall apply.

Whenever the Equipment under test (EUT) is provided with a detachable antenna, the EUT shall be tested with the antenna fitted in a manner typical of normal intended use, unless specified otherwise.

### 4.2 Arrangements for test signals

The provisions of EN 301 489-1 [1], clause 4.2 shall apply with the following modifications.

The wanted RF signal nominal frequency shall be selected by setting the CDMA channel to an appropriate number.

A communication link shall be set up with a suitable base station simulator (hereafter called "the test system") according to the Radio Configuration (RC) supported by the mobile station (3GPP2 C.S0011-A [5] using full data rate only. The test system shall be located outside of the test environment.

Where possible the test of the transmitter section and receiver section of the EUT may be carried out simultaneously to reduce test time.

Immunity tests on mobile and portable radio equipment (MS) shall be performed in two modes of operation:

- with a communication link established (traffic mode); and
- in idle mode.

When the EUT is required to be in the traffic mode, a call is set up using Loopback Service Option (see 3GPP2 C.S0013-A [6]) according to the radio configuration supported by the mobile station (see clause 1.3 in 3GPP2 C.S0011-A [5]), and the following conditions shall be met:

- the EUT shall be commanded to operate at maximum transmit power;
- variable Rate shall be disabled;
- MS shall be set for maximum rate.

When the EUT is required to be in the idle mode, then the following conditions shall be met:

- enable the receiver for CDMA-only mode;
- the test system shall simulate a Base Station with the Paging Channel or the Quick Paging Channel or Forward Common Control Channel/Broadcast Control Channel on one carrier. The MS shall be synchronized and be able to respond to paging messages. The MS shall not initiate a call (mobile station originated call), re-registration, or message transmission.

Adequate measures shall be taken to avoid the effect of the immunity test RF signal on the measuring equipment.

#### 4.2.1 Arrangements for test signals at the input of transmitters

The provisions of EN 301 489-1 [1], clause 4.2.1 shall apply.

#### 4.2.2 Arrangements for test signals at the output of transmitters

The provisions of EN 301 489-1 [1], clause 4.2.2 shall apply with the following modifications.

Where the equipment incorporates an external 50  $\Omega$  RF antenna connector that is normally connected via a coaxial cable, then the wanted signal to establish a communication link shall be delivered from that connector by a coaxial cable.

Where the equipment incorporates an external 50  $\Omega$  RF antenna connector, but this port is not normally connected via a coaxial cable, and where the equipment does not incorporate an external 50  $\Omega$  RF connector (integral antenna equipment), then the wanted signal, to establish a communication link, shall be delivered from the equipment to an antenna located within the test environment.

### 4.2.3 Arrangements for test signals at the input of receivers

The provisions of EN 301 489-1 [1], clause 4.2.3 shall apply with the following modifications.

Where the equipment incorporates an external 50  $\Omega$  RF antenna connector that is normally connected via a coaxial cable, then the wanted signal to establish a communication link shall be delivered to that connector by a coaxial cable.

Where the equipment incorporates an external 50  $\Omega$  RF antenna connector, but this port is not normally connected via a coaxial cable, and where the equipment does not incorporate an external 50  $\Omega$  RF connector (integral antenna equipment), then the wanted signal, to establish a communication link, shall be presented to the equipment from an antenna located within the test environment.

For immunity testing the wanted input signal level shall be set to no more than 40 dB above the reference sensitivity level to provide a stable communication link.

For emission testing the wanted input signal level shall be no more than 15 dB above the reference sensitivity level, to ensure that the performance of the measuring receiver is operating within its dynamic range.

The reference sensitivity level is defined in 3GPP2 C.S0011-A [5].

The input signal levels used during the tests shall be recorded in the test report.

### 4.2.4 Arrangements for test signals at the output of receivers

The provisions of EN 301 489-1 [1], clause 4.2.4 shall apply with the following modification.

The specific arrangement for test signals at the output of receivers are found in annex B for receivers operating with analogue speech output (voice), and in annex C for receivers operating with non-speech output (data).

## 4.3 Exclusion bands

The provisions of EN 301 489-1 [1], clause 4.3 shall apply.

## 4.4 Narrow band responses on receivers

Responses on receivers or duplex transceivers occurring during immunity tests at discrete frequencies, which are narrow band responses (spurious responses), are identified by the following method:

- if during an immunity test the quantity being monitored goes outside the specified tolerances (see clause 6.2), it is necessary to establish whether the deviation is due to an unwanted effect on the receiver of the MS or on the test system (narrow band response) or to a wide band (EMC) phenomenon. Therefore, the test shall be repeated with the MS channel frequency increased and then decreased to the first adjacent RF CDMA channel;
- if the deviation in either or both frequency offset cases disappears, the response is considered as a narrow band response;
- if the deviation does not disappear, the procedure is repeated with the MS channel frequency increased and then decreased to the second adjacent RF CDMA channels centre frequency.- If the deviation still does not disappear with the increased and/or decreased immunity RF test signal, the phenomenon is considered wide band and therefore an EMC problem and the equipment fails the test.

For immunity tests, narrow band responses shall be disregarded.

## 4.5 Normal test modulation

For immunity tests in voice call mode, the overall audio reverse link and forward link performance of the radio equipment shall be calibrated before the start of the tests. The calibration procedure is presented in annex B.1.

Immunity tests in voice call mode shall be performed without the application of any external modulation input signal.

For immunity tests in data transfer mode, the tests shall be performed with the application of an appropriate external modulation input signal such that the performance of the data transmission can be monitored. The performance assessment of the data transmission procedure is presented in annex C.

---

# 5 Performance assessment

## 5.1 General

The provisions of EN 301 489-1 [1], clause 5.1 shall apply with the following modification.

The information about the bandwidth of the IF filter immediately preceding the demodulator set out in EN 301 489-1 [1], clause 5.1 is not applicable to radio equipment in the scope of the present document.

## 5.2 Equipment which can provide a continuous communication link

The provisions of EN 301 489-1 [1], clause 5.2 shall apply.

## 5.3 Equipment which does not provide a continuous communication link

The provisions of EN 301 489-1 [1], clause 5.3 shall apply.

## 5.4 Ancillary equipment

The provisions of EN 301 489-1 [1], clause 5.4 shall apply with the following modification.

Ancillary equipment shall be tested with it connected to an MS in which case compliance shall be demonstrated for the combination of ancillary and radio equipment to the appropriate clauses of the present document.

## 5.5 Equipment classification

The provisions of EN 301 489-1 [1], clause 5.5 shall apply.

---

# 6 Performance criteria

## 6.1 General

The equipment shall meet the performance criteria specified in this clause, clauses 6.2 and 6.3, as appropriate.

The maintenance of a communications link shall be assessed using an indicator, which may be part of the test system, or of the EUT.

If an equipment is of a specialized nature, that the performance criteria described in the following clauses are not appropriate, then the manufacturer shall declare, for inclusion in the test report, his own specification for an acceptable level of performance or degradation of performance during and/or after testing, as required by the present document.

Immunity tests shall be performed with the EUT set into traffic mode of operation. For transmitters, the tests shall also be performed in idle mode and the transmitter shall not unintentionally operate.

## 6.2 Performance criteria for continuous phenomena

A communication link shall be established at the start of the test, and maintained during the test, see clauses 4.1 and 4.2.

For transmission of digital data (in data transfer mode of operation), the performance criteria shall be the following:

- The Frame Error Rate (FER) using 9600 bps only data rate shall not exceed 0,5% with 95% confidence (see clause 6.6 in 3GPP2 C.S0011-A [5]).

For transmission of analogue speech or audio signals (in speech mode of operation), the performance criteria is applicable to the reverse link (RL) and forward link (FL)) audio outputs and these shall be at least 35 dB less than the reference levels recorded during the calibration procedure. This measurement is performed using an audio band pass filter of 200 Hz width, centred on 1 kHz (see annex A).

NOTE: If a high level background audio noise is present during the immunity tests, then the audio band pass filter may be reduced down to a minimum of 40 Hz bandwidth with a centre frequency of 1 kHz.

At the conclusion of the test, the EUT shall operate as intended with no loss of user control functions or stored data, and the communication link shall have been maintained.

## 6.3 Performance criteria for transient phenomena

A communications link shall be established at the start of the test, see clauses 4.1 and 4.2.

At the conclusion of each exposure it shall be verified that the communications link has been maintained. At the conclusion of the total test comprising the series of individual exposures, the EUT shall operate as intended with no loss of user control functions or stored data, as declared by the manufacturer, and the communications link shall have been maintained.

---

# 7 Applicability overview tables

## 7.1 Emission

### 7.1.1 General

EN 301 489-1 [1], table 2 contains the applicability of EMC emission measurements to the relevant ports of radio and/or associated ancillary equipment.

### 7.1.2 Special conditions

The following special conditions set out in table 1, relate to the emission test methods used in the EN 301 489-1 [1], clause 8.

No special conditions shall apply to UE in the scope of the present document.

## 7.2 Immunity

### 7.2.1 General

EN 301 489-1 [1], table 3 contains the applicability of EMC immunity measurements to the relevant ports of radio and/or associated ancillary equipment.

### 7.2.2 Special conditions

The following special conditions set out in table 2, relate to the immunity test methods used in EN 301 489 1 [1], clause 9.

**Table 2: Special conditions for EMC immunity tests**

Reference to clauses in EN 301 489-1 [1]	Special product-related conditions, additional to or modifying the test conditions in EN 301 489-1 [1], clause 9
9.2 Radio frequency electromagnetic field (80 MHz to 1 000 MHz) 9.2.2 Test method	when using the max hold detector method (see annex B) at each test frequency step initially an unmodulated test signal shall be applied. Then the test modulation shall be applied.
9.5 Radio frequency, common mode; 9.5.2 Test method	There is no exclusion band for the equipment in the scope of the present document. when using the max hold detector method (see annex B) at each test frequency step initially an unmodulated test signal shall be applied. Then the test modulation shall be applied. The procedure used for identifying narrowband responses does not apply to conducted immunity tests in the frequency range 150 kHz to 80 MHz (4.4).

---

## Annex A (informative): Examples of mobile and portable radio and ancillary equipment for digital cellular radio telecommunications systems within the scope of the present document

The present document covers types of mobile and/or portable digital cellular radio telecommunications equipment as set out below.

---

### A.1 Mobile and portable radio equipment, and ancillary equipment for IMT-2000 CDMA Multi-carrier Systems

The present document applies to IMT-2000 CDMA Multi-carrier systems digital cellular mobile and portable radio equipment. Definitions for mobile and portable radio and associated ancillary equipment within the scope of the present document are found in the following functional radio specification:

- 3GPP2 C.S0011-A [5]: "Recommended Minimum Performance Standards for cdma2000 Spread Spectrum Mobile Stations".



## B.2 Measurement of audio levels

When the audio levels are measured during testing the EUT software shall be configured for voice applications. If the algorithms for noise and echo cancellation are not disabled, then the level shall be measured using a max-hold detection on the audio level meter in order to determine the level before the noise and echo cancellation algorithms become effective.

The level of the output signal from the forward link speech channel of the EUT at the mobile or portable's ear piece shall be assessed by measuring the Sound Pressure Level (SPL) as shown in figure B.2. When an external loudspeaker is used the acoustical coupler shall be fixed to the loudspeaker in the position used during the calibration. The level of the decoded output signal from the reverse link speech channel of the EUT at the analogue output of the test system shall be measured. Pick up of extraneous background noise by the microphone of the EUT shall be minimized.

NOTE: If the equipment is designed for use with external transducers, they shall be included in the test configuration. If the equipment does not include acoustical transducers the line voltage developed across specified termination impedance may be measured

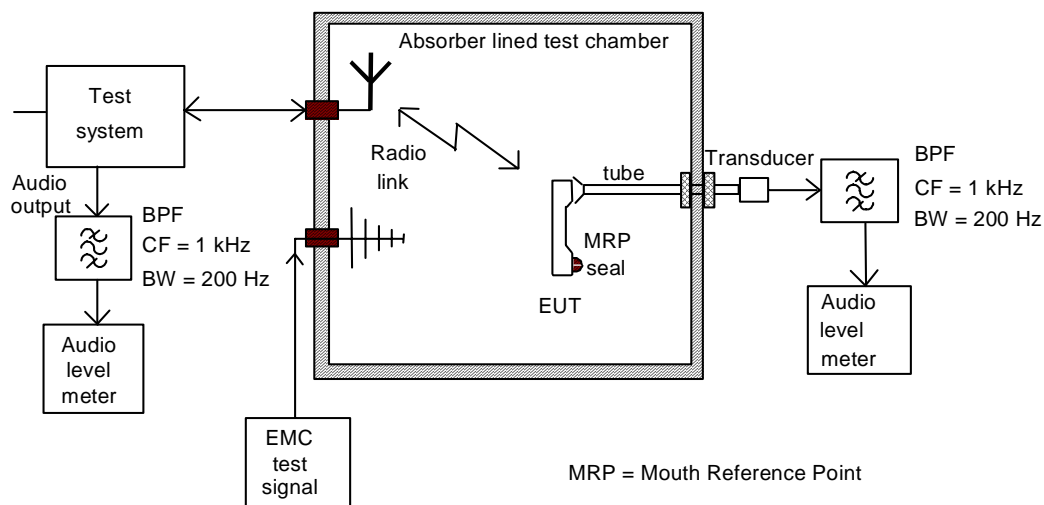

Figure B.2: Audio breakthrough measurement, test set-up for portable equipment



---

## Annex C (normative): Performance assessment of data transfer call. Error Rates

### C.1 Calibration of data transfer

For the EUT, calibration of the data transfer may be performed by assessing the Frame Error Rate (FER), or End-User data error ratio before applying the RF immunity test signal (defined in EN 301 489-1 [1], clauses 9.2 and 9.5).

---

### C.2 Derivation of Error Rates

The manufacturer shall provide the method for calculating the Frame Error Ratio. Known data patterns shall be transferred bi-directionally from end-to-end (the whole of the RL and FL will be exercised). Performance assessment shall be made at each frequency step. Comparison between transmitted known data and received data shall result in the Frame Error Rate (FER).

The data patterns used should be of sufficient length to give valid results and should be equivalent to the used channel bit rate.

Possible data patterns for assessing the Error Ratio are FER and User Data. Detailed description of FER can be found from 3GPP2 C.S0011-A [5] (2000).

End- User Data may be used where FER measurements are not appropriate, and is a manufacturers decision (see below).

NOTE: For example, in the cases when the EUT consists of MS with data application ancillary and the data application ancillary itself does not support a loopback function that can be applied for the assesment of FER, as specified in 3GPP2 C.S0011-A [5] (2000). This would lead into a situation where the data application ancillary is not exercised, i.e. the data transfer loop is not end-to-end.

The characteristics of the End- User Data used for testing (format, size, typical data throughput rate, additional error corrections etc.) and the necessary test equipment shall be delivered to enable the assessment of the EUT.

Following formula may apply to End- User Data:

$$\text{Frame ErrorRate} = \left( \frac{\text{erroneuos frames}}{\text{total number of frames received}} \times 100 \right) = n\%$$

---

### C.3 EUT without data application ancillary

Data monitoring Devices are here considered as part of the Test System. Arrangements should be made by the manufacturer, if needed, to couple the Data monitoring Device by a method which does not affect the radiated electromagnetic field (e.g. ultra sonic or optical).

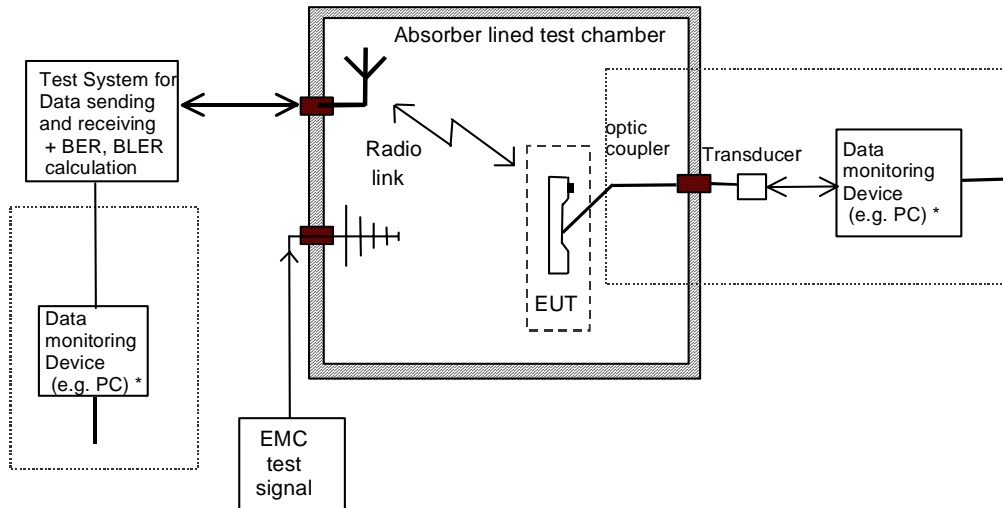

Figure C.1: Error Rate assessment, test set-up for EUT without data application ancillary

## C.4 EUT with data application ancillary

The Data monitoring Device is here considered as a part of the Test System. The Data application ancillary should be part of the data transfer (RL and FL) loop and is included in the EUT configuration.

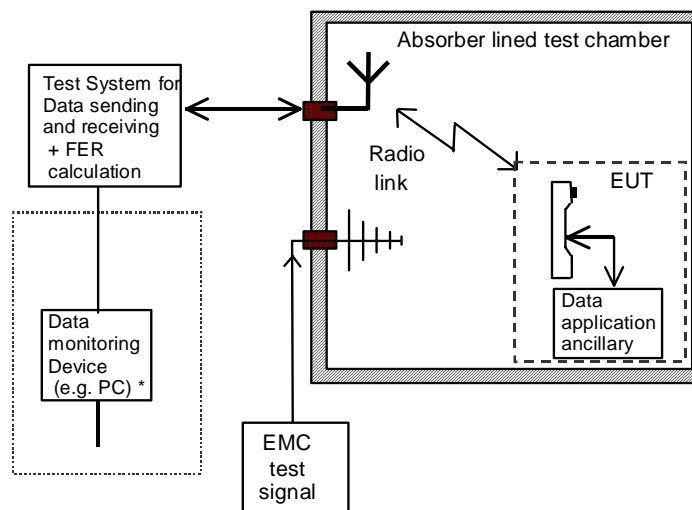

Figure C.2: Error Rate assessment, test set-up for EUT with data application ancillary

---

## History

<b>Document history</b>			
V1.1.1	December 2000	Public Enquiry	PE 20010427: 2000-12-27 to 2001-04-27