

# ETSI EN 301 489-24 V1.1.1 (2001-09)

---

*Candidate Harmonized European Standard (Telecommunications series)*

**Electromagnetic compatibility  
and Radio spectrum Matters (ERM);  
ElectroMagnetic Compatibility (EMC) standard  
for radio equipment and services;  
Part 24: Specific conditions for IMT-2000 CDMA  
Direct Spread (UTRA) for Mobile and  
portable (UE) radio and ancillary equipment**

---



---

**Reference**

REN/ERM-EMC-227-2

---

**Keywords**EMC, IMT-2000, radio, regulation, terminal,  
UMTS**ETSI**

---

650 Route des Lucioles  
F-06921 Sophia Antipolis Cedex - FRANCE

Tel.: +33 4 92 94 42 00 Fax: +33 4 93 65 47 16

Siret N° 348 623 562 00017 - NAF 742 C  
Association à but non lucratif enregistrée à la  
Sous-Préfecture de Grasse (06) N° 7803/88

---

**Important notice**

Individual copies of the present document can be downloaded from:

<http://www.etsi.org>

The present document may be made available in more than one electronic version or in print. In any case of existing or perceived difference in contents between such versions, the reference version is the Portable Document Format (PDF). In case of dispute, the reference shall be the printing on ETSI printers of the PDF version kept on a specific network drive within ETSI Secretariat.

Users of the present document should be aware that the document may be subject to revision or change of status. Information on the current status of this and other ETSI documents is available at

<http://portal.etsi.org/tb/status/status.asp>

If you find errors in the present document, send your comment to:

[editor@etsi.fr](mailto:editor@etsi.fr)

---

**Copyright Notification**

No part may be reproduced except as authorized by written permission.  
The copyright and the foregoing restriction extend to reproduction in all media.

© European Telecommunications Standards Institute 2001.  
All rights reserved.

# Contents

Intellectual Property Rights .....	5
Foreword.....	5
1 Scope .....	7
2 References .....	7
3 Definitions and abbreviations.....	8
3.1 Definitions .....	8
3.2 Abbreviations .....	9
4 Test conditions .....	9
4.1 General .....	9
4.2 Arrangements for test signals .....	9
4.2.1 Arrangements for test signals at the input of transmitters.....	10
4.2.2 Arrangements for test signals at the output of transmitters.....	10
4.2.3 Arrangements for test signals at the input of receivers .....	10
4.2.4 Arrangements for test signals at the output of receivers .....	11
4.3 Exclusion bands.....	11
4.4 Narrow band responses on receivers .....	11
4.5 Normal test modulation .....	11
5 Performance assessment.....	11
5.1 General .....	11
5.2 Equipment which can provide a continuous communication link.....	11
5.3 Equipment which does not provide a communication link.....	11
5.4 Ancillary equipment .....	12
5.5 Equipment classification .....	12
6 Performance criteria .....	12
6.1 General .....	12
6.2 Performance criteria for continuous phenomena.....	12
6.3 Performance criteria for Transient phenomena .....	13
7 Applicability overview tables.....	13
7.1 Emission .....	13
7.1.1 General.....	13
7.1.2 Special conditions .....	13
7.2 Immunity .....	13
7.2.1 General.....	13
7.2.2 Special conditions.....	14
<b>Annex A (informative):</b> <b>Examples of mobile and portable radio and ancillary equipment for digital cellular radio telecommunications systems within the scope of the present document.....</b>	<b>15</b>
A.1 Mobile and portable radio equipment, and ancillary equipment for the IMT-2000 CDMA Direct Spread (UTRA) .....	15
<b>Annex B (normative):</b> <b>Performance assessment voice call. Audio breakthrough.....</b>	<b>16</b>
B.1 Calibration of audio levels .....	16
B.2 Measurement of audio levels.....	17
<b>Annex C (normative):</b> <b>Performance assessment of data transfer call. Error Ratios .....</b>	<b>18</b>
C.1 Calibration of data transfer.....	18
C.2 Derivation of Error Ratios .....	18

C.3	EUT without data application ancillary.....	19
C.4	EUT with data application ancillary.....	19
<b>Annex D (informative):</b>	<b>Bibliography.....</b>	<b>20</b>
History .....		21

---

# Intellectual Property Rights

IPRs essential or potentially essential to the present document may have been declared to ETSI. The information pertaining to these essential IPRs, if any, is publicly available for **ETSI members and non-members**, and can be found in ETSI SR 000 314: *"Intellectual Property Rights (IPRs); Essential, or potentially Essential, IPRs notified to ETSI in respect of ETSI standards"*, which is available from the ETSI Secretariat. Latest updates are available on the ETSI Web server (<http://www.etsi.org/legal/home.htm>).

Pursuant to the ETSI IPR Policy, no investigation, including IPR searches, has been carried out by ETSI. No guarantee can be given as to the existence of other IPRs not referenced in ETSI SR 000 314 (or the updates on the ETSI Web server) which are, or may be, or may become, essential to the present document.

---

## Foreword

This Candidate Harmonized European Standard (Telecommunications series) has been produced by ETSI Technical Committee Electromagnetic compatibility and Radio spectrum Matters (ERM).

The present document has been produced by ETSI in response to a mandate from the European Commission issued under the Council Directive 98/34/EC [4] (as amended) laying down a procedure for the provision of information in the field of technical standards and regulation.

The present document is intended to become a Harmonized Standard, the reference of which will be published in the Official Journal of the European Communities referencing the Council Directive on the approximation of the laws of the Member States relating to electromagnetic compatibility ("the EMC Directive") (89/336/EEC [3] as amended) and Directive 1999/5/EC [2] of the European Parliament and of the Council of 9 March 1999 on radio equipment and telecommunications terminal equipment and the mutual recognition of their conformity ("the R&TTE Directive").

The present document is part 24 of a multipart deliverable, covering the ElectroMagnetic Compatibility (EMC) standard, as identified below:

- Part 1: "Common technical requirements";
- Part 2: "Specific conditions for radio paging equipment";
- Part 3: "Specific conditions for Short-Range Devices (SRD) operating on frequencies between 9 kHz and 40 GHz";
- Part 4: "Specific conditions for fixed radio links and ancillary equipment and services";
- Part 5: "Specific conditions for Private land Mobile Radio (PMR) and ancillary equipment (speech and non-speech)";
- Part 6: "Specific conditions for Digital Enhanced Cordless Telecommunications (DECT) equipment";
- Part 7: "Specific conditions for mobile and portable radio and ancillary equipment of digital cellular radio telecommunications systems (GSM and DCS)";
- Part 8: "Specific conditions for GSM base stations";
- Part 9: "Specific conditions for wireless microphones and similar Radio Frequency (RF) audio link equipment";
- Part 10: "Specific conditions for First (CT1 and CT1+) and Second Generation Cordless Telephone (CT2) equipment";
- Part 11: "Specific conditions for analogue terrestrial sound broadcasting (Amplitude Modulation (AM) and Frequency Modulation (FM)) service transmitters";
- Part 12: "Specific conditions for Very Small Aperture Terminal, Satellite Interactive Earth Stations operated in the frequency ranges between 4 GHz and 30 GHz in the Fixed Satellite Service (FSS)";
- Part 13: "Specific conditions for Citizens' Band (CB) radio and ancillary equipment (speech and non-speech)";

- Part 14: "Specific conditions for analogue and digital terrestrial TV broadcasting service transmitters";
- Part 15: "Specific conditions for commercially available amateur radio equipment";
- Part 16: "Specific conditions for analogue cellular radio communications equipment, mobile and portable";
- Part 17: "Specific conditions for Wideband data and HIPERLAN equipment";
- Part 18: "Specific conditions for Terrestrial Trunked Radio (TETRA) equipment";
- Part 19: "Specific conditions for Receive Only Mobile Earth Stations (ROMES) operating in the 1,5 GHz band providing data communications";
- Part 20: "Specific conditions for Mobile Earth Stations (MES) used in the Mobile Satellite Services (MSS)";
- Part 22: "Specific conditions for ground based VHF aeronautical mobile and fixed radio equipment";
- Part 23: "Specific conditions for IMT-2000 CDMA Direct Spread (UTRA) Base Station (BS) radio, repeater and ancillary equipment";
- Part 24: "Specific conditions for IMT-2000 CDMA Direct Spread (UTRA) for Mobile and portable (UE) radio and ancillary equipment";**
- Part 25: "Specific conditions for IMT-2000 CDMA Multi-carrier Mobile Stations and ancillary equipment";
- Part 26: "Specific conditions for IMT-2000 CDMA Multi-carrier Base Stations and ancillary equipment".

<b>National transposition dates</b>	
Date of adoption of this EN:	31 August 2001
Date of latest announcement of this EN (doa):	30 November 2001
Date of latest publication of new National Standard or endorsement of this EN (dop/e):	31 May 2002
Date of withdrawal of any conflicting National Standard (dow):	31 May 2003

---

# 1 Scope

The present document, together with EN 301 489-1 [1], covers the assessment of 3<sup>rd</sup> generation" digital cellular (IMT-2000 CDMA Direct Spread) (UTRA) mobile and portable (UE) radio terminal equipment and associated ancillary equipment in respect of ElectroMagnetic Compatibility (EMC).

Technical specifications related to the antenna port and emissions from the enclosure port of radio equipment are not included in the present document. Such technical specifications are found in the relevant product standards for the effective use of the radio spectrum.

The present document specifies the applicable test conditions, performance assessment and performance criteria of 3<sup>rd</sup> generation" digital cellular (IMT-2000 CDMA Direct Spread) (UTRA) mobile and portable (UE) radio terminal equipment and associated ancillary equipment.

Examples of digital cellular mobile and portable radio equipment covered by the present document are given in annex A.

In case of differences (for instance concerning special conditions, definitions, abbreviations) between the present document and EN 301 489-1 [1], the provisions of the present document take precedence.

Base station (BS) equipment operating within network infrastructure is outside the scope of the present document. However, the present document does cover mobile and portable equipment that is intended to be operated in a fixed location while connected to the AC mains (see clause 5.5).

The environment classification and the emission and immunity requirements used in the present document are as stated in EN 301 489-1 [1], except for any special conditions included in the present document.

---

# 2 References

The following documents contain provisions which, through reference in this text, constitute provisions of the present document.

- References are either specific (identified by date of publication, edition number, version number, etc.) or non-specific.
- For a specific reference, subsequent revisions do not apply.
- For a non-specific reference, subsequent revisions do apply.

- [1] ETSI EN 301 489-1 (V1.2.1): "Electromagnetic compatibility and Radio spectrum Matters (ERM); ElectroMagnetic Compatibility (EMC) standard for radio equipment and services; Part 1: Common technical requirements".
- [2] Directive 1999/5/EC of the European Parliament and of the Council of 9 March 1999 on radio equipment and telecommunications terminal equipment and the mutual recognition of their conformity.
- [3] Council Directive 89/336/EEC of 3 May 1989 on the approximation of the laws of the Member States relating to electromagnetic compatibility.
- [4] Directive 98/34/EC of the European Parliament and of the Council of 22 June 1998 laying down a procedure for the provision of information in the field of technical standards and regulations.
- [5] Void.
- [6] ETSI TR 125 990: "Universal Mobile Telecommunications System (UMTS); Vocabulary (3G TR 25.990 version 3.0.0 Release 1999)".
- [7] ETSI TR 121 905: "Universal Mobile Telecommunications System (UMTS); Vocabulary for 3GPP Specifications (3GPP TR 21.905 version 3.2.0 Release 1999)".

- [8] ETSI TS 134 108: "Universal Mobile Telecommunications System (UMTS) Common Test Environments for User Equipment (UE) Conformance Testing (3GPP TS 34.108 version 3.1.0 Release 1999)".
- [9] ETSI TS 125 101: "Universal Mobile Telecommunications System (UMTS); UE Radio Transmission and Reception (FDD) (3GPP TS 25.101 version 3.4.0 Release 1999)".
- [10] ETSI TS 134 109: "Universal Mobile Telecommunications System (UMTS); Terminal logical test interface; Special conformance testing functions (3GPP TS 34.109 version 3.1.0 Release 1999)".
- [11] ETSI ETR 027 (1991): "Radio Equipment and Systems (RES); Methods of measurement for private mobile radio equipment".
- [12] ITU-T Recommendation P.64: "Determination of sensitivity/frequency characteristics of local telephone systems".
- [13] ITU-T Recommendation P.76: "Determination of loudness ratings; fundamental principles".
- [14] ETSI TS 125 102: "Universal Mobile Telecommunications System (UMTS); UTRA (UE) TDD; Radio Transmission and Reception (3GPP TS 25.102 version 3.4.0 Release 1999)".

---

## 3 Definitions and abbreviations

### 3.1 Definitions

For the purposes of the present document, the terms and definitions given in EN 301 489-1 [1], clause 3 and the following apply:

**camped on a cell:** UE is in idle mode and has completed the cell selection/reselection process and has chosen a cell. The UE monitors system information and (in most cases) paging information.

NOTE 1: The services may be limited, and the PLMN may not be aware of the existence of the UE within the chosen cell.

**data application ancillary:** ancillary which provides send and/or receive data access to UMTS services via UE

**End-User data:** manufacturer defined data patterns for data transfer testing.

NOTE 2: Represents EUT's typical user application data pattern (e.g. photo, video, text file, message) in its characteristics.

**idle mode:** state of User Equipment (UE) when switched on but with no Radio Resource Control (RRC) connection

**International Mobile Telecommunications-2000 (IMT-2000):** third generation mobile systems which provide access, by means of one or more radio links, to a wide range of telecommunications services supported by the fixed telecommunication networks (e.g. PSTN, ISDN, or IP), and to other services which are specific to mobile users

**maximum average power:** average transmitter output power obtained over any specified time interval, including periods with no transmission, when the transmit time slots are at the maximum power setting

**traffic mode:** state of User Equipment (UE) when switched on and with Radio Resource Control (RRC) connection established

**Universal Terrestrial Radio Access (UTRA):** radio access network of the telecommunications system, incorporating mobile cellular and other functionality, that is the subject of specifications produced by 3GPP

**User Equipment (UE):** "Mobile Station" (MS) which is an entity capable of accessing a set of UTRA services via one or more radio interfaces.

NOTE 3: This entity may be stationary or in motion within the UTRA service area while accessing the UTRA services, and may simultaneously serve one or more users.



## 3.2 Abbreviations

For the purposes of the present document, the following abbreviations apply:

BER	Bit Error Ratio
BLER	Block Error Ratio
BS	Base Station
CRC	Cyclic Redundancy Check
DL	Down Link (From BS to UE)
DTX	Discontinuous Transmission (see note)
FDD	Frequency Division Duplex
IMT-2000	International Mobile Telecommunications 2000
MRP	Mouth Reference Point (artificial head)
MS	Mobile Station
RRC	Radio Resource Control
SPL	Sound Pressure Level
TDD	Time Division Duplex
UARFCN	UTRA Absolute Radio Frequency Channel Number (see note)
UE	User Equipment
UL	Up Link (From UE to BS)
UTRA	Universal Terrestrial Radio Access

NOTE: Refer to Terminology specifications TS 121 905 [7] and TS 125 990 [6] for further details.

---

## 4 Test conditions

For the purpose of the present document, the test conditions of EN 301 489-1 [1], clause 4, shall apply as appropriate. Further product related test conditions for digital cellular mobile and portable radio equipment are specified in the present document.

### 4.1 General

Whenever the Equipment under test (EUT) is provided with a detachable antenna, the EUT shall be tested with the antenna fitted in a manner typical of normal intended use, unless specified otherwise.

### 4.2 Arrangements for test signals

The provisions of EN 301 489-1 [1], clause 4.2 shall apply with the following modifications.

The wanted RF signal nominal frequency shall be selected by setting the UTRA Absolute Radio Frequency Channel Number (UARFCN) to an appropriate number.

A communication link shall be set up with a suitable base station simulator (hereafter called "the test system"). The test system shall be located outside of the test environment.

Where possible the test of the transmitter section and receiver section of the EUT may be carried out simultaneously to reduce test time;

Immunity tests shall be performed in two modes of operation:

- with a communication link established (traffic mode); and
- in the idle mode.

When the EUT is required to be in the traffic mode, a call is set up according to the Generic call set-up procedure and the following conditions shall be met.

See TS 134 108 [8] and TS 134 109 [10] Logical Test Interface for details regarding generic call set-up procedure and BER, BLER test loop scenarios:

- set and send continuously Up power control commands to the UE;
- the DTX shall be disabled;
- Inner Loop Power Control shall be enabled;
- transmitting and/or receiving (UL/DL) bit rate for reference test channel shall be 12,2 kbps.

When the EUT is required to be in the idle mode the following conditions shall be met:

- UE shall be camped on a cell;
- UE shall perform Location Registration (LR) before the test, but not during the test;
- UE's neighbour cell list shall be empty;
- Paging repetition period and DRX cycle shall be set to minimum (shortest possible time interval).

Adequate measures shall be taken to avoid the effect of immunity RF test signals on the measuring equipment.

#### 4.2.1 Arrangements for test signals at the input of transmitters

The provisions of EN 301 489-1 [1], clause 4.2.1 shall apply.

#### 4.2.2 Arrangements for test signals at the output of transmitters

The provisions of EN 301 489-1 [1], clause 4.2.2 shall apply with the following modifications.

Where the equipment incorporates an external 50  $\Omega$  RF antenna connector that is normally connected via a coaxial cable, then the wanted signal to establish a communication link shall be delivered from that connector by a coaxial cable.

Where the equipment incorporates an external 50  $\Omega$  RF antenna connector, but this port is not normally connected via a coaxial cable, and where the equipment does not incorporate an external 50  $\Omega$  RF connector (integral antenna equipment), then the wanted signal, to establish a communication link, shall be delivered from the equipment to an antenna located within the test environment.

#### 4.2.3 Arrangements for test signals at the input of receivers

The provisions of EN 301 489-1 [1], clause 4.2.3 shall apply with the following modifications.

Where the equipment incorporates an external 50  $\Omega$  RF antenna connector that is normally connected via a coaxial cable, then the wanted signal to establish a communication link shall be delivered to that connector by a coaxial cable.

Where the equipment incorporates an external 50  $\Omega$  RF antenna connector, but this port is not normally connected via a coaxial cable, and where the equipment does not incorporate an external 50  $\Omega$  RF connector (integral antenna equipment), then the wanted signal, to establish a communication link, shall be presented to the equipment from an antenna located within the test environment.

For immunity testing the wanted RF signal level at the input of the EUT shall be at least 40 dB above the reference sensitivity level to provide a stable communication link. The reference sensitivity level is defined in TS 125 101 [9] and TS 125 102 [14].

For emission testing the wanted RF signal level at the input of the measuring receiver shall be no more than 15 dB above the reference sensitivity level, to ensure that it operates within its dynamic range.

#### 4.2.4 Arrangements for test signals at the output of receivers

The provisions of EN 301 489-1 [1], clause 4.2.4 shall apply with the following modification.

The specific arrangement for test signals at the output of receivers are in annexes B and C.

### 4.3 Exclusion bands

For radio equipment in the scope of the present document the exclusion band does not apply.

### 4.4 Narrow band responses on receivers

Responses on receivers or duplex transceivers occurring during the immunity tests at discrete frequencies, which are narrow band responses (spurious responses), are identified by the following method:

- if during an immunity test the quantity being monitored goes outside the specified tolerances, it is necessary to establish whether the deviation is due to an unwanted effect on the receiver of the UE or on the test system (narrow band response) or to a wideband (EMC) phenomenon. Therefore, the test shall be repeated with the UARFCN increased or decreased by 25 (DL / UL);
- if the deviation does not disappear, the procedure is repeated with the UARFCN increased or decreased by 50 from the original value (DL / UL);
- if the deviation does not disappear with the increased and/or decreased UARFCN, the phenomenon is considered wideband and therefore an EMC problem and the equipment fails the test.

Narrow band responses are disregarded.

### 4.5 Normal test modulation

For transmission of analogue speech or audio signals (voice call mode), immunity tests shall be performed without the application of any external modulation input signal.

The overall audio uplink (UL) and downlink (DL) performance of the radio equipment shall be calibrated before the start of the tests. The calibration procedure is explained in annex B, clause B.1.

The immunity tests in the data transfer mode shall be performed with the application of an appropriate external modulation input signal such that the performance of the data call can be monitored. For assessment of the data transfer mode, refer to annex C.

---

## 5 Performance assessment

### 5.1 General

The provision of EN 301 489-1 [1], clause 5.1 shall apply.

### 5.2 Equipment which can provide a continuous communication link

The provision of EN 301 489-1 [1], clause 5.2 shall apply.

### 5.3 Equipment which does not provide a communication link

The provision of EN 301 489-1 [1], clause 5.3 shall apply.

## 5.4 Ancillary equipment

The provision of EN 301 489-1 [1], clause 5.4 shall apply with the following modification.

Ancillary equipment shall be tested with it connected to a UE in which case compliance shall be demonstrated to the appropriate clauses of the present document.

## 5.5 Equipment classification

The provision of EN 301 489-1 [1], clause 5.5 shall apply.

---

# 6 Performance criteria

## 6.1 General

The equipment shall meet the performance criteria specified in this clause and clauses 6.2 and 6.3 as appropriate.

The maintenance of a communications link shall be assessed by using an indicator, which may be part of the test system or the equipment under test.

If an equipment is of a specialized nature, that the performance criteria described in the following clauses are not appropriate, then the manufacturer shall declare, for inclusion in the test report, his own specification for an acceptable level of performance or degradation of performance during and/or after testing, as required by the present document.

The performance criteria specified by the manufacturer shall give the same degree of immunity protection as called for in the following clauses.

In addition, the test shall also be performed in idle mode to ensure the transmitter does not unintentionally operate.

The requirements apply to all types of UTRA (FDD or TDD) for the UE.

## 6.2 Performance criteria for continuous phenomena

A communication link shall be established at the start of the test, and maintained during the test, clauses 4.1 and 4.2.

In the data transfer mode, the performance criteria can be one of the following:

- if the BER (as referred in TS 134 109 [10]) is used, it shall not exceed 0,001 during the test sequence;
- if the BLER (as referred in TS 134 109 [10]) is used, it shall not exceed 0,01 during the test sequence.

The BLER calculation shall be based on evaluating the CRC on each transport block.

In the speech mode, the performance criteria shall be that the up link and downlink speech output levels shall be at least 35 dB less than the recorded reference levels, when measured through an audio band pass filter of width 200 Hz, centred on 1 kHz (annex B).

**NOTE:** When there is a high level of background audio noise present, the filter bandwidth can be reduced down to a minimum of 40 Hz.

At the conclusion of the test, the EUT shall operate as intended with no loss of user control functions or stored data, and the communication link shall have been maintained.

In addition to confirming the above performance in traffic mode, the test shall be performed in idle mode, and the transmitter shall not unintentionally operate.

## 6.3 Performance criteria for Transient phenomena

A communications link shall be established at the start of the test, clauses 4.1 and 4.2.

At the conclusion of each exposure the EUT shall operate with no user noticeable loss of the communication link.

At the conclusion of the total test comprising the series of individual exposures, the EUT shall operate as intended with no loss of user control functions or stored data, as declared by the manufacturer, and the communication link shall have been maintained.

In addition to confirming the above performance in traffic mode, the test shall also be performed in idle mode, and the transmitter shall not unintentionally operate.

---

## 7 Applicability overview tables

### 7.1 Emission

#### 7.1.1 General

EN 301 489-1 [1], table 2 contains the applicability of EMC emission measurements to the relevant ports of radio and/or associated ancillary equipment.

#### 7.1.2 Special conditions

No special conditions shall apply to UE in the scope of the present document.

### 7.2 Immunity

#### 7.2.1 General

EN 301 489-1 [1], table 3 contains the applicability of EMC immunity measurements to the relevant ports of radio and/or associated ancillary equipment.

## 7.2.2 Special conditions

The following special conditions set out in table 1, relate to the immunity test methods used in the EN 301 489-1 [1], clause 9.

**Table 1: Special conditions for EMC immunity measurements**

Reference to clauses in EN 301 489-1 [1]	Special product-related conditions, additional to or modifying the test conditions in EN 301 489-1 [1], clause 9
<b>9.2 Radio frequency electromagnetic field (80 MHz to 1 000 MHz);</b> <b>9.2.2 Test method</b>	When using the max hold detector method (see annex B) at each test frequency step initially an unmodulated test signal shall be applied. Then the test modulation shall be applied.
<b>9.5 Radio frequency, common mode;</b> <b>9.5.2 Test method</b>	There is no exclusion band for the equipment in the scope of the present document. when using the max hold detector method (see annex B) at each test frequency step initially an unmodulated test signal shall be applied. Then the test modulation shall be applied. The procedure used for identifying narrowband responses does not apply to conducted immunity tests in the frequency range 150 kHz to 80 MHz (see clause 4.4).
<b>9.6 Transients and surges in the vehicular environment;</b> <b>9.6.2 Test method</b>	Mobile radio and ancillary equipment in the scope of the present document are not subject to immunity tests with pulse no 7. For radio equipment designed to operate at 12 V DC and 24 V DC supplies it is sufficient to apply pulse 4 for 12V DC systems and perform the 24 V DC tests set out in clause 9.6.2.2 of EN 301 489-1 [1].
<b>9.6 Transients and surges in the vehicular environment;</b> <b>9.6.3 Performance criteria</b>	During tests with pulses 3a and 3b, the performance criteria TT shall apply, see clause 6.3.

---

## Annex A (informative): Examples of mobile and portable radio and ancillary equipment for digital cellular radio telecommunications systems within the scope of the present document

The present document covers types of mobile and/or portable digital cellular radio telecommunications equipment as set out below.

---

### A.1 Mobile and portable radio equipment, and ancillary equipment for the IMT-2000 CDMA Direct Spread (UTRA)

The present document applies to the 3rd Generation Partnership Project (UTRA) digital cellular mobile and portable radio equipment. Definitions for mobile and portable radio and associated ancillary equipment within the scope of the present document are found in the following functional radio specification:

- ETSI TS 125 101: "Universal Mobile Telecommunications System (UMTS); UE Radio Transmission and Reception (FDD) (3GPP TS 25.101 version 3.4.0 Release 1999)".
- ETSI TS 125 102: "Universal Mobile Telecommunications System (UMTS); UTRA (UE) TDD; Radio Transmission and Reception (3GPP TS 25.102 version 3.4.0 Release 1999)".

## Annex B (normative): Performance assessment voice call. Audio breakthrough

### B.1 Calibration of audio levels

For the portable the audio calibration is performed as follows.

Set the EUT volume to provide the nominal audio level if specified by the manufacturer. If no such level is specified, the centre volume step shall be used.

Prior to the test sequence, the reference level of the speech output signal on both the downlink and uplink shall be recorded on the test instrumentation, as shown in figure B.1. The reference level shall be equivalent to the SPL of 0 dBPa at 1 kHz at the input of the acoustical coupler described in ETR 027 [11], for the downlink, and -5 dBPa at 1 kHz at the mouth reference point (MRP) defined in ITU-T Recommendation P.64 [12] for the uplink.

NOTE 1: The MRP is defined with respect to an artificial head defined in ITU-T Recommendation P.76 [13]. The handset shall be mounted on the artificial head such that the ear piece is centred at the artificial ear.

NOTE 2: If the equipment does not include acoustical transducers (e.g. a microphone or loudspeaker) the manufacturer shall specify the equivalent electrical reference levels.

The voice processor may often apply noise and echo cancellation algorithms, which attempt to eliminate or reduce steady state audio signals as e.g. the 1 kHz calibration signals. These algorithms may be disabled during the calibration procedure. Specialized test software may be required. If the algorithms cannot be disabled then the reference level shall be measured using a max-hold detection on the audio level meter in order to determine the level before the noise and echo cancellation algorithms become effective.

In handsfree applications an external loudspeaker is used. The SPL from the external loudspeaker is normally much higher than from the earpiece of the portable in order to overcome a high ambient noise level. The downlink reference level shall be increased in order to compensate for the difference. Alternatively, the distance between the loudspeaker and the measuring microphone shall be adjusted during the measurement procedure in accordance with the manufacturers specification. It is important that the dynamic range of the test instrumentation is not exceeded.

Normally no corrections are made to the uplink reference level. In case it is not possible to perform the above calibration (e.g. a PC card with headset) the manufacturer shall specify the distance between the MRP and the microphone.

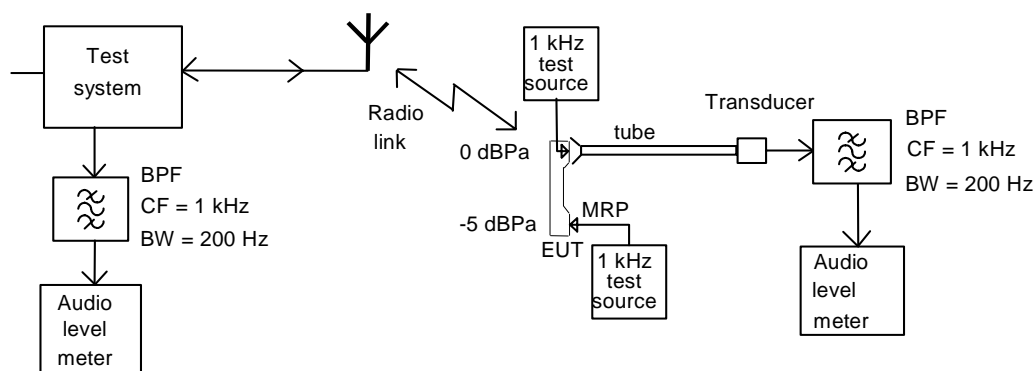

MRP = Mouth Reference Point

NOTE: The EUT is in position during calibration of the uplink, but not during calibration of the downlink where the EUT is replaced by the 1 kHz test audio source. During calibration of the uplink the mouthpiece shall be placed with respect to the MRP in a way representing intended use.

**Figure B.1: Audio breakthrough measurement, calibration set-up for portable equipment**



## B.2 Measurement of audio levels

When the audio levels are measured during testing the EUT software shall be configured for voice applications. If the algorithms for noise and echo cancellation are not disabled, then the level shall be measured using a max-hold detection on the audio level meter in order to determine the level before the noise and echo cancellation algorithms become effective.

The level of the output signal from the downlink speech channel of the EUT at the mobile or portable's ear piece shall be assessed by measuring the Sound Pressure Level (SPL) as shown in figure B.2. When an external loudspeaker is used the acoustical coupler shall be fixed to the loudspeaker in the position used during the calibration. The level of the decoded output signal from the uplink speech channel of the EUT at the analogue output of the test system shall be measured. Pick up of extraneous background noise by the microphone of the EUT shall be minimized.

NOTE: If the equipment is designed for use with external transducers, they shall be included in the test configuration. If the equipment does not include acoustical transducers the line voltage developed across specified termination impedance may be measured

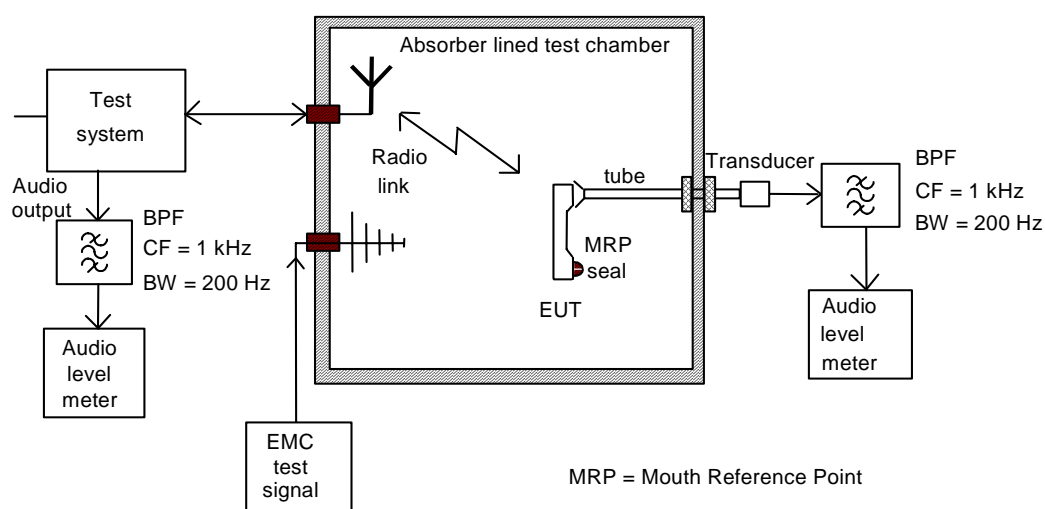

Figure B.2: Audio breakthrough measurement, test set-up for portable equipment

---

## Annex C (normative): Performance assessment of data transfer call. Error Ratios

### C.1 Calibration of data transfer

For the EUT, calibration of the data transfer may be performed by assessing the Bit Error Ratio (BER), Block Error Ratio (BLER) or End-User data error ratio before applying the RF immunity test signal (defined in EN 301 489-1 [1], clauses 9.2 and 9.5)

---

### C.2 Derivation of Error Ratios

The manufacturer shall provide the method for calculating the Error Ratio. Known data patterns shall be transferred bi-directionally from end-to-end (the whole of the UL and DL will be exercised). Performance assessment shall be made at each frequency step. Comparison between transmitted known data and received data shall result in the Error Ratio.

The data patterns used should be of sufficient length to give valid results and should be equivalent to the used channel bit rate.

Possible data patterns for assessing the Error Ratio are BER, BLER and User Data. Detailed description of BER and BLER can be found from TS 134 109 [10].

End-User Data may be used where BER and BLER measurements are not appropriate, and is a manufacturers decision (see below).

NOTE: For example, in the cases when the EUT consists of UE with data application ancillary and the data application ancillary itself does not support a loopback function that can be applied for the assessment of BER or BLER, as specified in TS 134 109 [10]. This would lead into a situation where the data application ancillary is not exercised, i.e. the data transfer loop is not end-to-end.

The characteristics of the End-User Data used for testing (format, size, typical data throughput rate, additional error corrections etc.) and the necessary test equipment shall be delivered to enable the assessment of the EUT.

Following formula may apply to End-User Data:

$$\text{ErrorRatio} = \left( \frac{\text{erroneuos(bits, bytes, symbols, etc.)}}{\text{total number of(bits, bytes, symbols, etc.)}} \times 100 \right) = n\%$$

(In case that high Error Ratios exist, ensure that errors are a consequence of EMC stress).

### C.3 EUT without data application ancillary

Data monitoring Devices are here considered as part of the Test System. Arrangements should be made by the manufacturer, if needed, to couple the Data monitoring Device by a method which does not affect the radiated electromagnetic field (e.g. ultrasonic or optical).

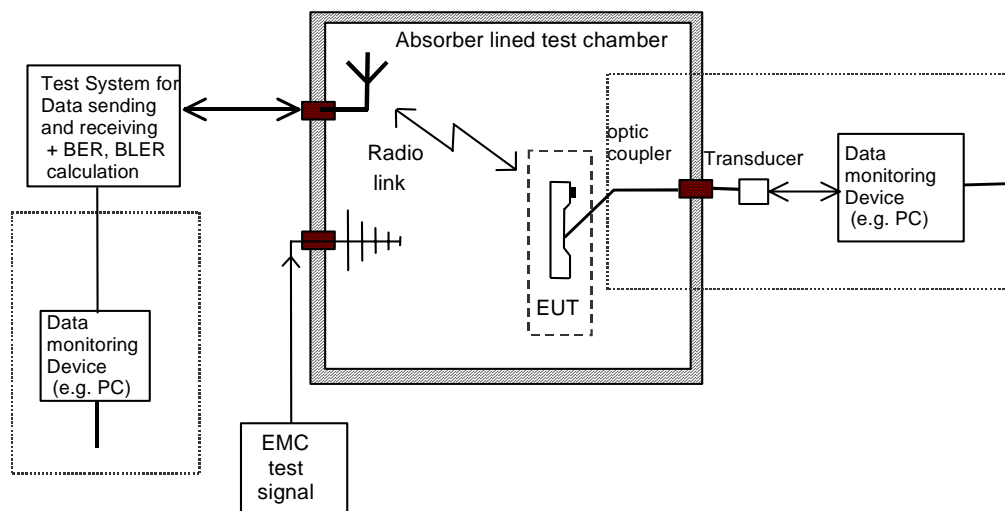

Figure C.1: Error Ratio assessment, test set-up for EUT without data application ancillary

### C.4 EUT with data application ancillary

The Data monitoring Device is here considered as a part of the Test System. The Data application ancillary should be part of the data transfer (UL and DL) loop and is included in the EUT configuration.

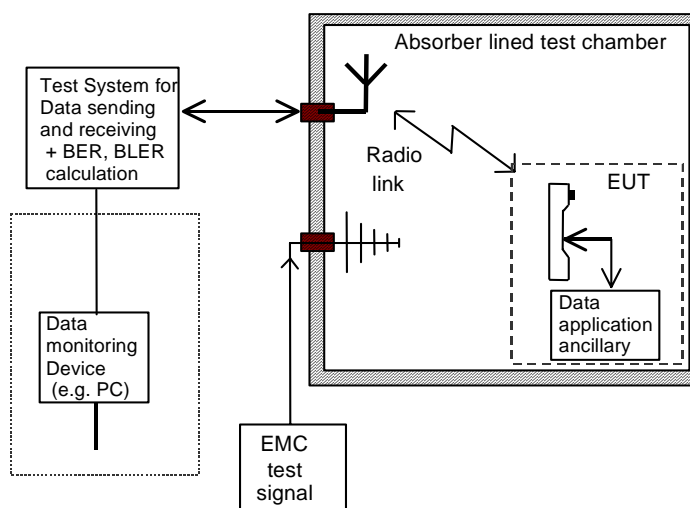

Figure C.2: Error Ratio assessment, test set-up for EUT with data application ancillary

---

## Annex D (informative): Bibliography

ETSI TS 134 121: "Universal Mobile Telecommunications System (UMTS); Terminal Conformance Specification; Radio Transmission and Reception (FDD) (3GPP TS 34.121 version 3.2.0 Release 1999)".

ETSI TS 134 122: "Universal Mobile Telecommunications System (UMTS) Terminal Conformance Specification; Radio Transmission and Reception (TDD) (3GPP TS 34.122 version 3.1.0 Release 1999)".

---

## History

<b>Document history</b>		
V1.1.1	December 2000	Public Enquiry PE 20010427: 2000-12-27 to 2001-04-27
V1.1.1	July 2001	Vote V 20010831: 2001-07-02 to 2001-08-31
V1.1.1	September 2001	Publication