

# ETSI EN 301 489-23 V1.1.1 (2001-09)

---

*Candidate Harmonized European Standard (Telecommunications series)*

**Electromagnetic compatibility  
and Radio spectrum Matters (ERM);  
ElectroMagnetic Compatibility (EMC) standard  
for radio equipment and services;  
Part 23: Specific conditions for IMT-2000 CDMA  
Direct Spread (UTRA) Base Station (BS) radio,  
repeater and ancillary equipment**

---



---

**Reference**

REN/ERM-EMC-227-1

---

**Keywords**Base station, EMC, IMT-2000, radio, regulation,  
UMTS**ETSI**

---

650 Route des Lucioles  
F-06921 Sophia Antipolis Cedex - FRANCE

Tel.: +33 4 92 94 42 00 Fax: +33 4 93 65 47 16

Siret N° 348 623 562 00017 - NAF 742 C  
Association à but non lucratif enregistrée à la  
Sous-Préfecture de Grasse (06) N° 7803/88

---

**Important notice**

Individual copies of the present document can be downloaded from:

<http://www.etsi.org>

The present document may be made available in more than one electronic version or in print. In any case of existing or perceived difference in contents between such versions, the reference version is the Portable Document Format (PDF). In case of dispute, the reference shall be the printing on ETSI printers of the PDF version kept on a specific network drive within ETSI Secretariat.

Users of the present document should be aware that the document may be subject to revision or change of status. Information on the current status of this and other ETSI documents is available at

<http://portal.etsi.org/tb/status/status.asp>

If you find errors in the present document, send your comment to:

[editor@etsi.fr](mailto:editor@etsi.fr)

---

**Copyright Notification**

No part may be reproduced except as authorized by written permission.  
The copyright and the foregoing restriction extend to reproduction in all media.

© European Telecommunications Standards Institute 2001.  
All rights reserved.

# Contents

Intellectual Property Rights .....	5
Foreword.....	5
1 Scope .....	7
2 References .....	7
3 Definitions and abbreviations.....	8
3.1 Definitions .....	8
3.2 Abbreviations .....	8
4 Test conditions .....	8
4.1 General .....	8
4.2 Arrangements for test signals .....	9
4.2.1 Arrangements for test signals at the input of transmitters.....	9
4.2.2 Arrangements for test signals at the output of transmitters.....	9
4.2.3 Arrangements for test signals at the input of receivers .....	9
4.2.4 Arrangements for test signals at the output of receivers .....	9
4.2.5 Arrangements for test signals for repeaters.....	9
4.3 Exclusion bands.....	9
4.4 Narrow band responses of receivers.....	9
4.5 Normal test modulation .....	10
5 Performance assessment.....	10
5.1 General .....	10
5.2 Equipment which can provide a continuous communication link .....	10
5.2.1 Assessment of BLER in Downlink .....	10
5.2.2 Assessment of BLER in Uplink.....	10
5.2.3 Assessment of RF gain variations of repeaters .....	11
5.3 Equipment which does not provide a continuous communication link .....	11
5.4 Ancillary equipment.....	11
5.5 Equipment classification .....	11
6 Performance criteria .....	11
6.1 Performance criteria for continuous phenomena applied to Base Stations (BS) and Repeaters.....	11
6.1.1 Base Stations (BS).....	11
6.1.2 Repeaters .....	11
6.2 Performance criteria for transient phenomena for Base Station (BS) and Repeaters .....	11
6.2.1 Base stations (BS).....	11
6.2.2 Repeaters .....	12
6.2.2.1 Repeaters, Performance criteria for voltage dips (> 60 %) and interruptions .....	12
6.3 Performance criteria for ancillary equipment tested on a stand alone basis .....	12
6.3.1 Performance criteria for continuous phenomena for ancillary equipment .....	12
6.3.2 Performance criteria for transient phenomena for ancillary equipment.....	12
7 Applicability overview tables.....	12
7.1 Emission .....	12
7.1.1 General.....	12
7.1.2 Special conditions .....	13
7.2 Immunity .....	13
7.2.1 General.....	13
7.2.2 Special conditions.....	13
<b>Annex A (informative): Examples of base station radio equipment for digital cellular radio telecommunications systems within the scope of the present document .....</b>	<b>15</b>
A.1 Base station equipment for IMT-2000 CDMA Direct Spread (UTRA).....	15

<b>Annex B (informative):</b>	<b>Bibliography.....</b>	<b>16</b>
History .....		17

---

# Intellectual Property Rights

IPRs essential or potentially essential to the present document may have been declared to ETSI. The information pertaining to these essential IPRs, if any, is publicly available for **ETSI members and non-members**, and can be found in ETSI SR 000 314: *"Intellectual Property Rights (IPRs); Essential, or potentially Essential, IPRs notified to ETSI in respect of ETSI standards"*, which is available from the ETSI Secretariat. Latest updates are available on the ETSI Web server (<http://www.etsi.org/legal/home.htm>).

Pursuant to the ETSI IPR Policy, no investigation, including IPR searches, has been carried out by ETSI. No guarantee can be given as to the existence of other IPRs not referenced in ETSI SR 000 314 (or the updates on the ETSI Web server) which are, or may be, or may become, essential to the present document.

---

## Foreword

This Candidate Harmonized European Standard (Telecommunications series) has been produced by ETSI Technical Committee Electromagnetic compatibility and Radio spectrum Matters (ERM).

The present document has been produced by ETSI in response to a mandate from the European Commission issued under the Council Directive 98/34/EC [4] (as amended) laying down a procedure for the provision of information in the field of technical standards and regulation.

The present document is intended to become a Harmonized Standard, the reference of which will be published in the Official Journal of the European Communities referencing the Council Directive on the approximation of the laws of the Member States relating to electromagnetic compatibility ("the EMC Directive") (89/336/EEC [3] as amended) and Directive 1999/5/EC [2] of the European Parliament and of the Council of 9 March 1999 on radio equipment and telecommunications terminal equipment and the mutual recognition of their conformity ("the R&TTE Directive").

The present document is part 23 of a multi-part deliverable, covering the ElectroMagnetic Compatibility (EMC) standard for radio equipment and services, as identified below:

- Part 1: "Common technical requirements";
- Part 2: "Specific conditions for radio paging equipment";
- Part 3: "Specific conditions for Short-Range Devices (SRD) operating on frequencies between 9 kHz and 40 GHz";
- Part 4: "Specific conditions for fixed radio links and ancillary equipment and services";
- Part 5: "Specific conditions for Private land Mobile Radio (PMR) and ancillary equipment (speech and non-speech)";
- Part 6: "Specific conditions for Digital Enhanced Cordless Telecommunications (DECT) equipment";
- Part 7: "Specific conditions for mobile and portable radio and ancillary equipment of digital cellular radio telecommunications systems (GSM and DCS)";
- Part 8: "Specific conditions for GSM base stations";
- Part 9: "Specific conditions for wireless microphones and similar Radio Frequency (RF) audio link equipment";
- Part 10: "Specific conditions for First (CT1 and CT1+) and Second Generation Cordless Telephone (CT2) equipment";
- Part 11: "Specific conditions for analogue terrestrial sound broadcasting (Amplitude Modulation (AM) and Frequency Modulation (FM)) service transmitters";
- Part 12: "Specific conditions for Very Small Aperture Terminal, Satellite Interactive Earth Stations operated in the frequency ranges between 4 GHz and 30 GHz in the Fixed Satellite Service (FSS)";
- Part 13: "Specific conditions for Citizens' Band (CB) radio and ancillary equipment (speech and non-speech)";

- Part 14: Specific conditions for analogue and digital terrestrial TV broadcasting service transmitters
- Part 15: "Specific conditions for commercially available amateur radio equipment";
- Part 16: "Specific conditions for analogue cellular radio communications equipment, mobile and portable";
- Part 17: "Specific conditions for Wideband data and HIPERLAN equipment";
- Part 18: "Specific conditions for Terrestrial Trunked Radio (TETRA) equipment";
- Part 19: "Specific conditions for Receive Only Mobile Earth Stations (ROMES) operating in the 1,5 GHz band providing data communications";
- Part 20: "Specific conditions for Mobile Earth Stations (MES) used in the Mobile Satellite Services (MSS)";
- Part 22: "Specific conditions for ground based VHF aeronautical mobile and fixed radio equipment";
- Part 23: "Specific conditions for IMT-2000 CDMA Direct Spread (UTRA) Base Station (BS) radio, Repeater and ancillary equipment";**
- Part 24: "Specific conditions for IMT-2000 CDMA Direct Spread (UTRA) for Mobile and portable (UE) radio and ancillary equipment";
- Part 25: "Specific conditions for IMT-2000 CDMA Multi-carrier Mobile Stations and ancillary equipment";
- Part 26: "Specific conditions for IMT-2000 CDMA Multi-carrier Base Stations and ancillary equipment".

<b>National transposition dates</b>	
Date of adoption of this EN:	31 August 2001
Date of latest announcement of this EN (doa):	30 November 2001
Date of latest publication of new National Standard or endorsement of this EN (dop/e):	31 May 2002
Date of withdrawal of any conflicting National Standard (dow):	31 May 2003

---

# 1 Scope

The present document, together with EN 301 489-1 [1], covers the assessment of 3<sup>rd</sup> generation" digital cellular (IMT-2000 CDMA Direct Spread) (UTRA) base station equipment, repeaters and associated ancillary equipment in respect of ElectroMagnetic Compatibility (EMC).

Technical specifications related to the antenna port and emissions from the enclosure port of radio equipment (base station (BS), and repeaters) are not included in the present document. Such technical specifications are found in the relevant product standards for the effective use of the radio spectrum.

The present document specifies the applicable test conditions, performance assessment and performance criteria of 3<sup>rd</sup> generation" digital cellular (IMT-2000 CDMA Direct Spread) (UTRA) base station radio equipment and associated ancillary equipment.

Examples of base station equipment covered by the present document are given in annex A.

In case of differences (for instance concerning special conditions, definitions, abbreviations) between the present document and EN 301 489-1 [1], the provisions of the present document take precedence.

The environmental classification and the emission and immunity requirements used in the present document are as stated in the part 1 of the present document, except for any special conditions included in the present document.

---

# 2 References

The following documents contain provisions which, through reference in this text, constitute provisions of the present document.

- References are either specific (identified by date of publication, edition number, version number, etc.) or non-specific.
- For a specific reference, subsequent revisions do not apply.
- For a non-specific reference, subsequent revisions do apply.

- [1] ETSI EN 301 489-1 (V1.2.1): "Electromagnetic compatibility and Radio spectrum Matters (ERM); ElectroMagnetic Compatibility (EMC) standard for radio equipment and services; Part 1: Common technical requirements".
- [2] Directive 1999/5/EC of the European Parliament and of the Council of 9 March 1999 on radio equipment and telecommunications terminal equipment and the mutual recognition of their conformity.
- [3] Council Directive 89/336/EEC of 3 May 1989 on the approximation of the laws of the Member States relating to electromagnetic compatibility.
- [4] Directive 98/34/EC of the European Parliament and of the Council of 22 June 1998 laying down a procedure for the provision of information in the field of technical standards and regulations.
- [5] ETSI TS 125 141: "Universal Mobile Telecommunications System (UMTS); Base station conformance testing (FDD) (3GPP TS 25.141 version 3.3.0 Release 1999)".
- [6] ETSI TS 125 142: "Universal Mobile Telecommunications System (UMTS); Base station conformance testing (TDD) (3GPP TS 25.142 version 3.3.0 Release 1999)".
- [7] ETSI TS 125 101: "Universal Mobile Telecommunications System (UMTS); UE Radio Transmission and Reception (FDD) (3GPP TS 25.101 version 3.4.0 Release 1999)".
- [8] ETSI TS 125 102: "Universal Mobile Telecommunications System (UMTS); UTRA (UE) TDD; Radio Transmission and Reception (3GPP TS 25.102 version 3.4.0 Release 1999)".

- [9] ETSI TS 125 143: "Universal Mobile Telecommunications System (UMTS); UTRA Repeater conformance testing (3GPP TS 25.143 version 4.0.0 Release 4)".

## 3 Definitions and abbreviations

### 3.1 Definitions

For the purposes of the present document, the terms and definitions given in EN 301 489-1 [1], clause 3 and the following apply:

**International Mobile Telecommunications-2000 (IMT-2000):** third generation mobile systems which provide access, by means of one or more radio links, to a wide range of telecommunications services supported by the fixed telecommunication networks (e.g. PSTN, ISDN, or IP), and to other services which are specific to mobile users

**signal and control port:** port which carries information or control signals, except from antenna and telecommunication ports

### 3.2 Abbreviations

For the purposes of the present document, the following abbreviations apply:

BLER	Block Error Ratio
BS	Base Station
CRC	Cyclic Redundancy Check
EMC	ElectroMagnetic Compatibility
EUT	Equipment Under Test
FDD	Frequency Division Duplex
IMT-2000	International Mobile Telecommunications 2000
Iub	Interface between RNC and BS.
RNC	Radio Network Controller
RF	Radio Frequency
TDD	Time Division Duplex
UTRA	Universal Terrestrial Radio Access

## 4 Test conditions

For the purpose of the present document, the test conditions of EN 301 489-1 [1], clause 4, shall apply as appropriate. Further product related test conditions for base station equipment are specified in the present document.

### 4.1 General

The equipment shall be tested in normal test environment defined in the conformance testing specification for base stations ETSI TS 125 141 [5] (for FDD) or ETSI TS 125 142 [6] (for TDD) or in the UTRA repeater conformance testing specification ETSI TS 125 143 [9]. The test conditions shall be recorded in the test report.

For emission and immunity tests the test arrangements, etc., as specified in the present document, clauses 4.2 to 4.5, shall apply.

For an EUT which contains more than one BS, it is sufficient to perform tests relating to connectors of each representative type of port forming part of the EUT.



## 4.2 Arrangements for test signals

The provisions of EN 301 489-1 [1], clause 4.2 shall apply, with the following modifications.

The wanted RF signal nominal frequency shall be selected by setting the UTRA Absolute Radio Frequency Channel Number (UARFCN) to an appropriate number.

A communication link shall be set up with a suitable test system capable of evaluating the EUT using the specified performance criteria at the air interface and/or the Iub interface. The test system shall be located outside of the test environment.

When the EUT is required to be in the transmit/receive mode, the following conditions shall be met:

- the EUT shall be commanded to operate at maximum rated transmit power;
- adequate measures shall be taken to avoid the effect of the unwanted signal on the measuring equipment.

### 4.2.1 Arrangements for test signals at the input of transmitters

The provisions of EN 301 489-1 [1], clause 4.2.1 shall apply.

### 4.2.2 Arrangements for test signals at the output of transmitters

The provisions of EN 301 489-1 [1], clause 4.2.2 shall apply.

### 4.2.3 Arrangements for test signals at the input of receivers

The provisions of EN 301 489-1 [1], clause 4.2.3 shall apply with the following modification.

The wanted input signal level shall be set to a level where the performance is not limited by the receiver noise floor or strong signal effects e.g. 15 dB above the reference sensitivity level as defined in ETSI TS 125 141 [5] [5] (for FDD) or ETSI TS 125 142 [6] (for TDD), to provide a stable communication link.

### 4.2.4 Arrangements for test signals at the output of receivers

The provisions of EN 301 489-1 [1], clause 4.2.4 shall apply.

### 4.2.5 Arrangements for test signals for repeaters

For immunity tests of repeaters, the wanted RF input signal shall be coupled to one antenna port at a level which will result, when measured, in the maximum rated RF output power per channel, as declared by the manufacturer. The test shall either be repeated with a wanted signal coupled to the other antenna port, or a single test shall be performed with the specified input signals being simultaneously coupled to both antenna ports.

## 4.3 Exclusion bands

For radio equipment in the scope of the present document the exclusion band does not apply.

## 4.4 Narrow band responses of receivers

Responses on receivers or duplex transceivers occurring during the immunity test at discrete frequencies which are narrow band responses (spurious responses), are identified by the following method:

- if during an immunity test the quantity being monitored goes outside the specified tolerances (clause 6.1), it is necessary to establish whether the deviation is due to a narrow band response or to a wide band (EMC) phenomenon. Therefore, the test shall be repeated with the unwanted signal frequency increased, and then decreased by 10 MHz;

- if the deviation disappears in either or both of the above 10 MHz offset cases, then the response is considered as a narrow band response;
- if the deviation does not disappear, this may be due to the fact that the offset has made the frequency of the unwanted signal correspond to the frequency of another narrow band response. Under these circumstances the procedure is repeated with the increase and decrease of the frequency of the unwanted signal set to 12,5 MHz;
- if the deviation does not disappear with the increased and/or decreased frequency, the phenomenon is considered wide band and therefore an EMC problem and the equipment fails the test.

Narrow band responses are disregarded.

## 4.5 Normal test modulation

A communication link shall be set up with a suitable base station system test equipment. The normal test modulation should be a bearer with the characteristics of data rate shown in table 1.

If the test is not performed using one of these bearers, (for example none of them are supported by the BS), the characteristics of the bearer used shall be declared by the manufacturer and recorded in the test report.

**Table 1: Bearer information data rate**

Bearer Information Data Rate
12,2 kbps
64 kbps
144 kbps
384 kbps

---

## 5 Performance assessment

### 5.1 General

The provision of EN 301 489-1 [1], clause 5.1 shall apply with the following modifications.

The characteristics of the bearer shall be recorded in the test report.

The information about the bandwidth of the IF amplifier immediately preceding the demodulator as set out in EN 301 489-1 [1] clause 5.1 is not applicable for radio equipment in the scope of the present document.

### 5.2 Equipment which can provide a continuous communication link

The provision of EN 301 489-1 [1], clause 5.2 shall apply.

#### 5.2.1 Assessment of BLER in Downlink

In order to assess the BLER of the bearer used during the immunity tests, the output of the transmitter shall be connected to an equipment which meets the requirements for the BLER assessment of ETSI TS 125 101 [7] in case of FDD and ETSI TS 125 102 [8] in case of TDD. The level of the signal supplied to the equipment should be within the range for which the assessment of BLER is not impaired. Power control shall be off during the immunity testing.

#### 5.2.2 Assessment of BLER in Uplink

The value of the BLER at the output of the receiver reported by the BS shall be monitored at Iub-interface by using a suitable test equipment.

### 5.2.3 Assessment of RF gain variations of repeaters

The parameter used for the performance assessment of a repeater is the RF gain within the operating frequency band.

## 5.3 Equipment which does not provide a continuous communication link

The provision of EN 301 489-1 [1], clause 5.3 shall apply.

## 5.4 Ancillary equipment

The provision of EN 301 489-1 [1], clause 5.4 shall apply.

## 5.5 Equipment classification

The provision of EN 301 489-1 [1], clause 5.5 shall apply.

---

# 6 Performance criteria

## 6.1 Performance criteria for continuous phenomena applied to Base Stations (BS) and Repeaters

The BLER calculation shall be based on evaluating the CRC on each transport block.

### 6.1.1 Base Stations (BS)

During immunity tests of the BS Uplink and Downlink paths the observed BLER shall be less than  $1 \times 10^{-2}$  and the BS shall operate as intended. If the Uplink and Downlink paths are evaluated as one loop then the criteria is less than  $2 \times 10^{-2}$ .

After each test case the BS shall operate as intended with no loss of user control functions or stored data, the communications link shall be maintained.

### 6.1.2 Repeaters

The RF gain of the EUT shall be measured throughout the period of exposure to the phenomenon. The RF gain measured during the test shall not deviate from the gain measured before the test by more than  $\pm 1$  dB.

At the conclusion of the test the EUT shall operate as intended with no loss of user control functions or stored data.

## 6.2 Performance criteria for transient phenomena for Base Station (BS) and Repeaters

### 6.2.1 Base stations (BS)

During immunity tests of the BS Uplink and Downlink paths, the observed BLER may temporarily be greater than  $1 \times 10^{-2}$ . If the Uplink and Downlink paths are evaluated as one loop then the criteria may temporarily be greater than  $2 \times 10^{-2}$ .

After each test case the BS shall operate as intended with no loss of user control functions or stored data, the communications link shall be maintained.

## 6.2.2 Repeaters

The RF gain of the EUT shall be measured before the test and after each exposure. At the conclusion of each exposure the gain of the EUT shall not have changed by more than  $\pm 1$  dB. At the conclusion of the total test comprising the series of individual exposures, the EUT shall operate as intended with no loss of user control functions or stored data, as declared by the manufacturer, and the gain of the EUT shall not have changed by more than  $\pm 1$  dB.

### 6.2.2.1 Repeaters, Performance criteria for voltage dips (> 60 %) and interruptions

Temporary loss of function is allowed, provided that the function is self-recoverable or can be restored by the operation of controls.

## 6.3 Performance criteria for ancillary equipment tested on a stand alone basis

The provision of EN 301 489-1 [1], clause 6.4 shall apply. In addition, the provisions of clauses 6.3.1 and 6.3.2 of the present document shall apply.

### 6.3.1 Performance criteria for continuous phenomena for ancillary equipment

The EUT shall continue to operate as intended during and after the test. No degradation of performance or loss of function is allowed below the performance level specified by the manufacturer, when the apparatus is used as intended. The performance level may be replaced by a permissible performance loss. If the minimum performance level or the permissible performance loss is not specified by the manufacturer, either of these may be derived from the product description and documentation and what the user may reasonably expect from the apparatus if used as intended.

### 6.3.2 Performance criteria for transient phenomena for ancillary equipment

The EUT shall continue to operate as intended after the test. No degradation of performance or loss of function is allowed below the performance level specified by the manufacturer, when the apparatus is used as intended. The performance level may be replaced by a permissible performance loss. During the test, degradation of performance is however allowed. If the minimum performance level or the permissible performance loss is not specified by the manufacturer, either of these may be derived from the product description and documentation and what the user may reasonably expect from the apparatus if used as intended.

---

## 7 Applicability overview tables

### 7.1 Emission

#### 7.1.1 General

EN 301 489-1 [1], table 2 contains the applicability of EMC emission measurements to the relevant ports of radio and/or associated ancillary equipment.

## 7.1.2 Special conditions

The following special conditions set out in table 2, relate to the emission test methods used in the EN 301 489-1 [1], clause 8.

**Table 2: Special conditions for EMC emission measurements**

Reference to clauses in EN 301 489-1 [1]	Special product-related conditions, additional to or modifying the test conditions in EN 301 489-1 [1], clause 8
<b>8.3 DC power input/output ports</b> <b>8.3.3 Limits</b>	For this type of equipment the limits of table 3 of the present document apply

**Table 3: Limits for conducted emissions**

Frequency range	Quasi-peak	Average
>0,15-0,5 MHz	79 dBuV	66 dBuV
>0,5-30 MHz	73 dBuV	60 dBuV

## 7.2 Immunity

### 7.2.1 General

EN 301 489-1 [1], table 4, contains the applicability of EMC immunity measurements to the relevant ports of radio and/or associated ancillary equipment.

### 7.2.2 Special conditions

The following special conditions set out in table 4 relate to the immunity test configurations set out in EN 301 489-1 [1], clause 9.1.

**Table 4: Special conditions for EMC immunity measurements**

Reference to clauses in EN 301 489-1 [1]	Special product-related conditions, additional to or modifying the test configuration in EN 301 489-1 [1], clause 9.1
<b>9.1 Test configuration</b>	<p>Immunity tests on the entire base station shall be performed by establishing communication links at the air-interface, e.g. with the mobile simulator, and the lub-interface, e.g. with an RNC simulator, and evaluating the BLER (see figure 1).</p> <p>Immunity tests shall be performed on both the Uplink and Downlink paths. The tests shall also include both the air-interface and lub-interface.</p> <p>BLER evaluation may be carried out at either interface, where appropriate, and the measurements for the Uplink and Downlink paths may be carried out as a single path looped at either the air-interface or lub-interface. In case of looping is used care has to be taken that the BLER information does not change due to looping. The BLER evaluation shall be based on the number of transmitted blocks i.e. including possible deleted blocks.</p>

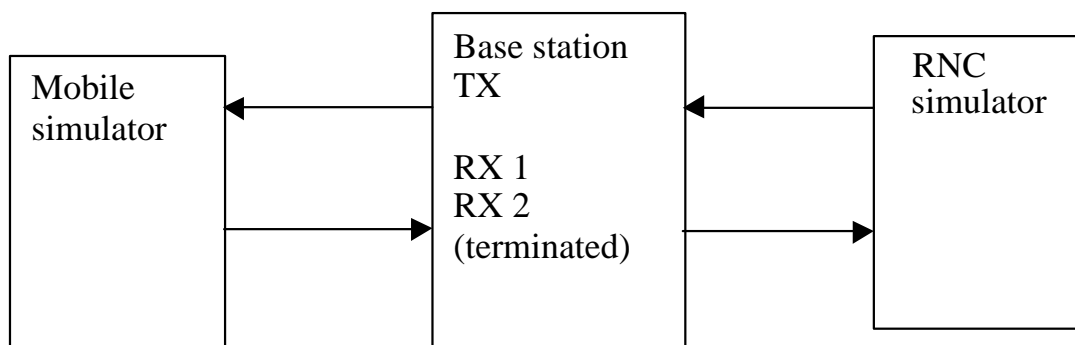

**Figure 1: Communication link set up for BS immunity measurement**

---

## Annex A (informative): Examples of base station radio equipment for digital cellular radio telecommunications systems within the scope of the present document

The present document covers types of base station digital cellular radio telecommunications equipment as set out below.

---

### A.1 Base station equipment for IMT-2000 CDMA Direct Spread (UTRA)

The present document applies to 3rd Generation Partnership Project (UTRA) radio equipment intended for use in digital cellular mobile radio services. Definitions for base station equipment within the scope of the present document are found in the following functional radio specification:

- ETSI TS 125 104: "Universal Mobile Telecommunications System (UMTS); UTRA (BS) FDD; Radio transmission and Reception (3GPP TS 25.104 version 3.4.0 Release 1999)";
- ETSI TS 125 105: "Universal Mobile Telecommunications System (UMTS); UTRA (BS) TDD; Radio transmission and Reception (3GPP TS 25.105 version 3.4.0 Release 1999)";
- ETSI TS 125 106: "Universal Mobile Telecommunications System (UMTS); UTRA Repeater Radio transmission and Reception (3GPP TS 25.106 version 4.0.0 Release 4)".

---

## Annex B (informative): Bibliography

ETSI TS 125 104: "Universal Mobile Telecommunications System (UMTS); UTRA (BS) FDD; Radio transmission and Reception (3GPP TS 25.104 version 3.4.0 Release 1999)".

ETSI TS 125 105: "Universal Mobile Telecommunications System (UMTS); UTRA (BS) TDD; Radio transmission and Reception (3GPP TS 25.105 version 3.4.0 Release 1999)".

ETSI TS 125 106: "Universal Mobile Telecommunications System (UMTS); UTRA Repeater Radio transmission and Reception (3GPP TS 25.106 version 4.0.0 Release 4)".



---

## History

<b>Document history</b>		
V1.1.1	December 2000	Public Enquiry PE 20010427: 2000-12-27 to 2001-04-27
V1.1.1	July 2001	Vote V 20010831: 2001-07-02 to 2001-08-31
V1.1.1	September 2001	Publication