

ETSI EN 301 489-20 V1.1.1 (2000-12)

Candidate Harmonized European Standard (Telecommunications series)

**Electromagnetic compatibility
and Radio spectrum Matters (ERM);
ElectroMagnetic Compatibility (EMC) standard
for radio equipment and services;
Part 20: Specific conditions for Mobile Earth Stations (MES)
used in the Mobile Satellite Services (MSS)**



Reference

DEN/ERM-EMC-219-20

KeywordsEMC, earth station, radio, MSS, regulation,
satellite, testing**ETSI**

650 Route des Lucioles
F-06921 Sophia Antipolis Cedex - FRANCE

Tel.: +33 4 92 94 42 00 Fax: +33 4 93 65 47 16

Siret N° 348 623 562 00017 - NAF 742 C
Association à but non lucratif enregistrée à la
Sous-Préfecture de Grasse (06) N° 7803/88

Important notice

Individual copies of the present document can be downloaded from:

<http://www.etsi.org>

The present document may be made available in more than one electronic version or in print. In any case of existing or perceived difference in contents between such versions, the reference version is the Portable Document Format (PDF). In case of dispute, the reference shall be the printing on ETSI printers of the PDF version kept on a specific network drive within ETSI Secretariat.

Users of the present document should be aware that the document may be subject to revision or change of status. Information on the current status of this and other ETSI documents is available at <http://www.etsi.org/tb/status/>

If you find errors in the present document, send your comment to:
editor@etsi.fr

Copyright Notification

No part may be reproduced except as authorized by written permission.
The copyright and the foregoing restriction extend to reproduction in all media.

© European Telecommunications Standards Institute 2000.
All rights reserved.

Contents

Intellectual Property Rights	4
Foreword.....	4
1 Scope.....	6
2 References.....	6
3 Definitions and abbreviations.....	7
3.1 Definitions.....	7
3.2 Abbreviations.....	7
4 Test conditions	8
4.1 General	8
4.2 Arrangements for test signals.....	8
4.2.1 Arrangements for test signals at the input of transmitters.....	9
4.2.2 Arrangements for test signals at the output of transmitters.....	9
4.2.3 Arrangements for test signals at the input of receivers.....	10
4.2.4 Arrangements for test signals at the output of receivers.....	10
4.2.5 Arrangements for testing transmitter and receiver together (as a system).....	10
4.3 Exclusion bands	10
4.3.1 Transmitter exclusion band	10
4.3.2 Receiver exclusion bands.....	10
4.4 Narrow band responses of receivers.....	10
5 Performance assessment	11
5.1 General	11
5.2 MES connected to host equipment.....	11
5.2.1 Alternative A: combined equipment	11
5.2.2 Alternative B: use of a test jig	11
5.3 Ancillary equipment.....	11
5.4 Equipment classification.....	12
6 Performance criteria.....	12
6.1 General	12
6.2 Performance criteria for Continuous Phenomena (CP).....	12
6.3 Performance criteria for Transient Phenomena (TP).....	12
7 Applicability overview.....	13
7.1 Emission	13
7.1.1 General.....	13
7.1.2 Special conditions.....	13
7.2 Immunity	13
7.2.1 General.....	13
7.2.2 Special conditions.....	13
Annex A (normative): Definitions of MESs within the scope of the present document.....	14
A.1 MESs operating within 1,6 GHz/2,4 GHz band	14
A.2 MESs operating within the 1,5 GHz/1,6 GHz.....	14
A.3 MESs operating within 2,0 GHz band	14
A.4 MESs operating below 1 GHz.....	15
A.5 MESs operating in the 11/12/14 GHz frequency bands.....	15
Bibliography.....	16
History	17

Intellectual Property Rights

IPRs essential or potentially essential to the present document may have been declared to ETSI. The information pertaining to these essential IPRs, if any, is publicly available for **ETSI members and non-members**, and can be found in ETSI SR 000 314: *"Intellectual Property Rights (IPRs); Essential, or potentially Essential, IPRs notified to ETSI in respect of ETSI standards"*, which is available from the ETSI Secretariat. Latest updates are available on the ETSI Web server (<http://www.etsi.org/ipr>).

Pursuant to the ETSI IPR Policy, no investigation, including IPR searches, has been carried out by ETSI. No guarantee can be given as to the existence of other IPRs not referenced in ETSI SR 000 314 (or the updates on the ETSI Web server) which are, or may be, or may become, essential to the present document.

Foreword

This Candidate Harmonized European Standard (Telecommunications series) has been produced by ETSI Technical Committee Electromagnetic compatibility and Radio spectrum Matters (ERM).

The present document has been produced by ETSI in response to a mandate from the European Commission issued under the Council Directive 98/34/EC [5] (as amended) laying down a procedure for the provision of information in the field of technical standards and regulation.

The present document, together with EN 301 489-1[1], is intended to become a Harmonized EMC Standard, the reference of which will be published in the Official Journal of the European Communities referencing the Council Directive on the approximation of the laws of the Member States relating to electromagnetic compatibility (the "EMC Directive" 89/336/EEC [3] as amended), and the Council Directive on the approximation of the laws of the Member States relating to radio equipment and telecommunications terminal equipment and the mutual recognition of their conformity (the "R&TTE Directive" 1999/5/EC [2]).

The present document is part 20 of a multi-part deliverable covering the ElectroMagnetic Compatibility (EMC) standard for radio equipment and services, as identified below:

- Part 1: "Common technical requirements";
- Part 2: "Specific conditions for radio paging equipment";
- Part 3: "Specific conditions for Short-Range Devices (SRD) operating on frequencies between 9 kHz and 40 GHz";
- Part 4: "Specific conditions for fixed radio links and ancillary equipment and services";
- Part 5: "Specific conditions for Private land Mobile Radio (PMR) and ancillary equipment (speech and non-speech)";
- Part 6: "Specific conditions for Digital Enhanced Cordless Telecommunications (DECT) equipment";
- Part 7: "Specific conditions for mobile and portable radio and ancillary equipment of digital cellular radio telecommunications systems (GSM and DCS)";
- Part 8: "Specific conditions for GSM base stations";
- Part 9: "Specific conditions for wireless microphones and similar Radio Frequency (RF) audio link equipment";
- Part 10: "Specific conditions for First (CT1 and CT1+) and Second Generation Cordless Telephone (CT2) equipment";
- Part 11: "Specific conditions for FM broadcasting transmitters";
- Part 12: "Specific conditions for Earth Stations operated in the frequency ranges between 4 GHz and 30 GHz in the Fixed Satellite Service (FSS)";
- Part 13: "Specific conditions for Citizens' Band (CB) radio and ancillary equipment (speech and non-speech)";
- Part 15: "Specific conditions for commercially available amateur radio equipment";

Part 16: "Specific conditions for analogue cellular radio communications equipment, mobile and portable";

Part 17: "Specific conditions for Wideband data and HIPERLAN equipment";

Part 18: "Specific conditions for Terrestrial Trunked Radio (TETRA) equipment";

Part 19: "Specific conditions for Receive Only Mobile Earth Stations (ROMES) operating in the 1,5 GHz band providing data communications";

Part 20: "Specific conditions for Mobile Earth Stations (MES) used in the Mobile Satellite Services (MSS)";

Part 22: "Specific conditions for ground based VHF aeronautical mobile and fixed radio equipment".

National transposition dates	
Date of adoption of this EN:	17 November 2000
Date of latest announcement of this EN (doa):	28 February 2001
Date of latest publication of new National Standard or endorsement of this EN (dop/e):	31 August 2001
Date of withdrawal of any conflicting National Standard (dow):	31 August 2002

1 Scope

The present document, together with EN 301 489-1 [1], covers the assessment of Mobile Earth Stations (MES) as defined in annex A used within Satellite radio services, and ancillary equipment in respect of ElectroMagnetic Compatibility (EMC).

Technical specifications related to the antenna port and emissions from the enclosure port of the equipment are not included in the present document. Such technical specifications are found in the relevant product standards for the effective use of the radio spectrum.

The present document specifies the applicable test conditions, performance assessment and performance criteria for MESs and for the associated ancillary equipment.

In case of differences (for instance concerning special conditions, definitions, abbreviations) between the present document and EN 301 489-1 [1], the provisions of the present document take precedence.

The environmental classification and the emission and immunity requirements used in the present document are as stated in EN 301 489-1 [1], except for any special conditions included in the present document. The applicable environment(s) referred to in EN 301 489-1 [1] where the MES may be used, shall be declared by the manufacturer.

For a multimode radio station, the present document only applies to the radio station when operated in the Mobile Satellite Service mode.

2 References

The following documents contain provisions which, through reference in this text, constitute provisions of the present document.

- References are either specific (identified by date of publication, edition number, version number, etc.) or non-specific.
- For a specific reference, subsequent revisions do not apply.
- For a non-specific reference, subsequent revisions do apply.
- A non-specific reference to an ETS shall also be taken to refer to later versions published as an EN with the same number.

- [1] ETSI EN 301 489-1 (V1.2.1) (2000): "Electromagnetic compatibility and Radio spectrum Matters (ERM); ElectroMagnetic Compatibility (EMC) standard for radio equipment and services; Part 1: Common technical requirements".
- [2] Directive 1999/5/EC of the European Parliament and of the Council of 9 March 1999 on radio equipment and telecommunications equipment and the mutual recognition of their conformity.
- [3] Council Directive 89/336/EEC of 3 May 1989 on the approximation of the laws of the Member States relating to electromagnetic compatibility.
- [4] ITU Radio Regulations (1998).
- [5] Directive 98/34/EC of the European Parliament and of the Council of 22 June 1998 laying down a procedure for the provision of information in the field of technical standards and regulations.

3 Definitions and abbreviations

3.1 Definitions

For the purposes of the present document, the terms and definitions given in EN 301 489-1 [1], clause 3, and the following apply:

carrier-on state (allocated a channel): state of an MES when it is transmitting a signal in a continuous or a non-continuous mode

carrier-off state (idle mode): state of an MES when it is powered-on but not transmitting a signal, i.e. not in a carrier-on state

host equipment: any equipment which has complete user functionality when not connected to the MES, and to which connection is necessary for the MES to offer additional functionality

Installable Equipment (IE), Internally Mounted Equipment (IME) and Externally Mounted Equipment (EME): Installable Equipment (IE) is an equipment which is intended to be installed in a vehicle. An IE may consist of one or several modules. The IE is composed of modules intended to be externally mounted and declared by the manufacturer as Externally Mounted Equipment (EME). The remaining module(s) are defined as Internally Mounted Equipment (IME)

multimode MES: indicates equipment that accommodates radio stations of different radio systems.

occupied bandwidth: see ITU Radio Regulations [4], part A, chapter 1, Terminology RR 147.

Portable Equipment (PE): is generally intended to be self-contained, free standing and portable. A PE would normally consist of a single module, but may consist of several interconnected modules.

NOTE: More than one of the equipment classifications can apply to certain equipment, as described in subclause 5.4, dependent upon the manufacturer's declaration of normal intended use.

transmission disabled state: state of an MES when it is not authorized to transmit by the Network Control Facilities (NCF)

3.2 Abbreviations

For the purposes of the present document, the following abbreviations apply:

BER	Bit Error Ratio
CMF	Control and Monitoring Functions
CP	performance criteria for Continuous Phenomena
EIRP	Equivalent Isotropically Radiated Power
EMC	ElectroMagnetic Compatibility
EME	Externally Mounted Equipment
EUT	Equipment Under Test
F-MES	Fixed MES
IE	Installable Equipment
IME	Internally Mounted Equipment
LBRDC	Low Bit Rate Data Communication
LEO	Low Earth Orbit
MES	Mobile Earth Station
MSS	Mobile Satellite Service
NCF	Network Control Facilities
P-MES	Portable MES
PE	Portable Equipment
PEP	Peak Envelope Power
QTMA	Quality of Transmission Measurement Apparatus
RF	Radio Frequency
STE	Special Test Equipment
S-PCN	Satellite Personal Communications Network

TP performance criteria for Transient Phenomena
V-MES Vehicle mounted MES

4 Test conditions

For the purposes of the present document, the test conditions of EN 301 489-1 [1], clause 4, shall apply as appropriate. Further product related test conditions for MES are specified in the present document.

4.1 General

For MESs with ancillary equipment and/or various ports, the number of test configurations shall be determined. The assessment shall include sufficient representative configurations of the MES to adequately exercise the equipment. These configurations shall be recorded in the test report.

In the following clauses, the Equipment Under Test (EUT) is the MES with the selected configuration of ancillary equipment.

The EUT operational frequencies used during the test, shall be recorded in the test report.

For testing and if physically separated from the MES, any voltage converter shall form part of the EUT.

Whenever the Equipment Under Test (EUT) is provided with an integral antenna, the EUT shall be tested with the antenna fitted in a manner typical of normal intended use.

For MES for which connection to a host equipment is necessary to offer additional functionality, the test configuration shall be as defined in subclause 5.2.

4.2 Arrangements for test signals

The provisions of EN 301 489-1 [1], subclause 4.2 shall apply.

In order to measure the system emission and electromagnetic immunity under operational conditions, proper arrangements shall be provided (by the manufacturer), e.g.:

- a) a Special Test Equipment (STE) to put the MES terminal in its normal operating mode, and providing the MES with a receive signal to emulate the operational conditions of reception. This equipment shall control the EUT, when it is capable of transmission, so that it switches between the transmission disabled, carrier-on and carrier-off states. This Special Test Equipment may also be used to achieve loop back mode operation;
- b) a specific Quality of Transmission Measurement Apparatus (QTMA).

EXAMPLE: The quality of transmission can concern:

- the audio signal;
- the BER;
- the message throughput;
- the continuity of the communication link; or
- a combination of them.

For the immunity tests of the EUT, a communications link shall be established between the EUT and the testing system. The EUT shall be placed in the operating mode.

For EUT for which connection to a host equipment is necessary to offer functionality the manufacturer shall select which of the alternative performance assessment configurations shall be used.

4.2.1 Arrangements for test signals at the input of transmitters

The provisions of EN 301 489-1 [1], subclause 4.2.1 shall apply.

4.2.2 Arrangements for test signals at the output of transmitters

The provisions of EN 301 489-1 [1], subclause 4.2.2 shall apply with the following modifications.

For transmitters, the EUT shall be operated at its maximum rated RF output Peak Envelope Power (PEP), or at a level not less than -6 dB relative to that power level in the event of declared thermal limitations. The transmitter shall be modulated with a test signal which represents normal operation as specified by the manufacturer. A communication link shall be established at the start of the test and be maintained throughout the test. A suggested test configuration is shown in figure 1.

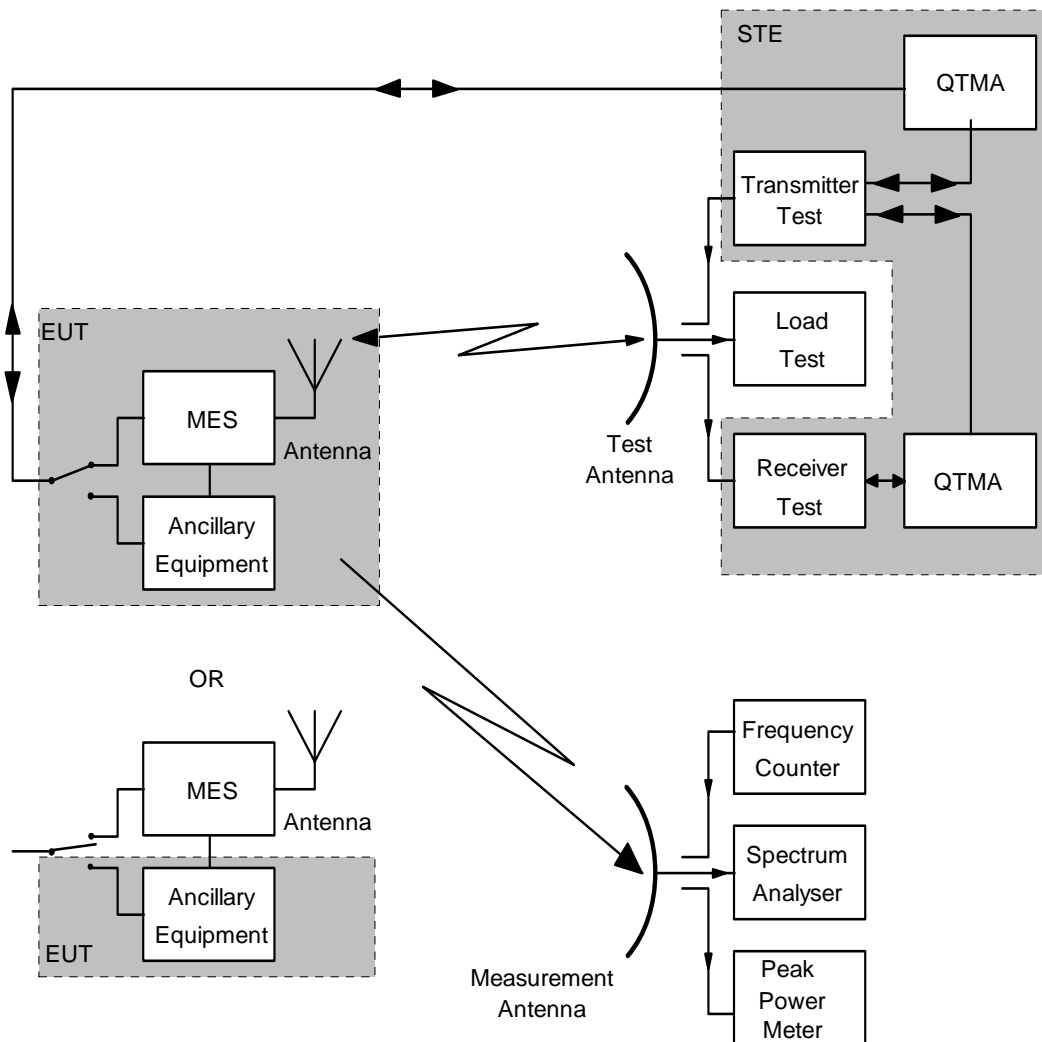

Figure 1: Suggested test configuration

4.2.3 Arrangements for test signals at the input of receivers

The provisions of EN 301 489-1 [1], subclause 4.2.3 shall apply with the following modifications.

For the immunity tests of receivers, the wanted input signal, coupled to the receiver, shall be modulated with a test signal specified by the manufacturer which represents normal operation.

For the measurement of the quality of transmission, a communications link shall be established and the wanted input signal shall be applied to the Radio Frequency (RF) input of the receiver. Signal level adjustment may be performed by adjustment of the test transmitter output level such that the received signal level is as close to the normal operation signal level as possible.

The Special Test Equipment (STE), the QTMA and the source of the wanted input signal shall be located outside the test environment.

4.2.4 Arrangements for test signals at the output of receivers

The provisions of EN 301 489-1 [1], subclause 4.2.4 shall apply with the following modifications.

For the quality of transmission measurements the MES may be put in a specific mode of operation where the received data are looped back to the modulation input of the transmitter part of the EUT.

4.2.5 Arrangements for testing transmitter and receiver together (as a system)

The provisions of EN 301 489-1 [1], subclause 4.2.5 shall apply.

4.3 Exclusion bands

The provision of EN 301 489-1 [1], subclause 4.3 shall apply with the following modifications:

- for MESs in the scope of the present document operating at frequencies above 1GHz, the exclusion band does not apply;
- there shall be no exclusion bands for the ancillary equipment.

4.3.1 Transmitter exclusion band

The exclusion band for transmitters operating at frequency below 1 GHz extends from the centre frequency minus twice the occupied bandwidth to the centre frequency plus twice the occupied bandwidth.

4.3.2 Receiver exclusion bands

The exclusion band for the receiver operating at frequency below 1 GHz part of the MES extends ± 5 % of the operating frequency.

4.4 Narrow band responses of receivers

The provisions of EN 301 489-1 [1], subclause 4.4 shall not apply.

5 Performance assessment

5.1 General

The provision of EN 301 489-1 [1], subclause 5.1 shall apply with the following modification.

In addition, the manufacturer shall, at the time of submission of the equipment for test, declare comprehensively the intended use of the equipment, and provide full and complete documentation necessary for user operation, testing and evaluation purposes. The present documentation shall include, but need not be limited to:

- the ranges of the operational parameters, e.g. the power delivered to the antenna, the frequency ranges, the operational frequencies;
- the ancillary equipment and/or host equipment to be combined with the MES for testing, if applicable;
- the user-control functions that are required for normal operation;
- the method and criteria to be used to assess the quality of transmission.

This information shall be in accordance with the documentation and the information leaflet accompanying the equipment and shall be recorded in the test report.

5.2 MES connected to host equipment

For MES parts for which connection to or integration with a host equipment is necessary in order to offer additional functionality, two alternative approaches are permitted. The manufacturer shall declare which alternative shall be used.

5.2.1 Alternative A: combined equipment

A combination of a MES and a specific type of host equipment is used for testing according to the present document.

Where more than one such combination is intended, testing shall not be repeated for combinations of MES and other host equipment where the latter are substantially similar, in particular such that host models are unlikely to significantly influence the intrinsic immunity and unwanted emissions of the MES.

Where more than one such combination is intended and host equipment are not substantially similar, one combination shall be tested against all requirements of the present document; all other combinations shall be tested separately for emissions only.

5.2.2 Alternative B: use of a test jig

Where the MES is intended for use with a variety of host equipment, the manufacturer shall supply a suitable test jig that is representative of the range of host equipment in which the device is intended to be used. The test jig shall allow the MES part to be powered and stimulated in a way similar to the way it would be powered and stimulated when connected to or inserted into the host equipment. Measurements shall be made to all requirements of the present document.

The test jig shall be designed such that alteration of the MES's intrinsic immunity and unwanted emissions is minimized.

5.3 Ancillary equipment

The provision of EN 301 489-1 [1], subclause 5.4 shall apply.

5.4 Equipment classification

The provision of EN 301 489-1 [1], subclause 5.5 shall apply with the following modifications.

The MES shall be classified in one or a combination of the following classes:

- vehicle mounted MES (V-MES) intended to be powered by the vehicle main battery, **shall meet the requirements for mobile equipment;**
- portable MES (P-MES) powered by a stand alone battery, **shall meet the requirements for portable equipment;**
- fixed MES (F-MES) powered either by a DC or AC mains, **shall meet the requirements for base station equipment.**

A V-MES is an Installable Equipment (IE); a P-MES is a Portable Equipment (PE).

6 Performance criteria

6.1 General

The equipment shall meet the minimum performance criteria as specified in subclauses 6.2 and 6.3.

The establishment of a communications link at the start of the test, the maintenance of the communications link and the assessment of the recovered signal information is used as the performance criteria to ensure that the essential functions of the EUT are evaluated during and after the test.

6.2 Performance criteria for Continuous Phenomena (CP)

The following procedures shall apply:

- during each individual exposure in the test sequence it shall be verified by the QTMA supplied by the manufacturer that the communications link is maintained, and that the quality of transmission observed is no worse than that declared by the manufacturer;
- at the conclusion of the test:
 - the EUT shall operate as intended with no loss of user control functions or stored data, as declared by the manufacturer;
 - the communications link has been maintained during the test; and
 - the quality of transmission observed is no worse than that declared by the manufacturer;
- under no circumstances shall the transmitter operate unintentionally.

6.3 Performance criteria for Transient Phenomena (TP)

The following procedures shall apply:

- after each exposure in the test sequence it shall be verified by the QTMA supplied by the manufacturer, that the communications link is maintained, and that the quality of transmission observed is no worse than that declared by the manufacturer;
- at the conclusion of the total test comprising a series of individual exposures it shall be verified that:
 - the EUT operates as intended with no loss of user control functions or stored data, as declared by the manufacturer;
 - the communications link has been maintained during the test; and

- the quality of transmission observed is no worse than that declared by the manufacturer;
- under no circumstances shall the transmitter operate unintentionally.

7 Applicability overview

7.1 Emission

7.1.1 General

EN 301 489-1 [1], table 2, contains the applicability of EMC emission measurements to the relevant ports of radio and/or associated ancillary equipment.

7.1.2 Special conditions

No special condition apply to MESs within the scope of the present document.

7.2 Immunity

7.2.1 General

EN 301 489-1 [1], table 3, contains the applicability of EMC immunity measurements to the relevant ports of radio and/or associated ancillary equipment.

7.2.2 Special conditions

The following special conditions set out in table 2, relate to the immunity test methods and performance criteria used in EN 301 489-1 [1], clause 9.

Table 2: Special conditions for EMC immunity tests

Reference to subclauses in EN 301 489-1 [1],	Special product-related conditions, additional to or modifying the test conditions in EN 301 489-1 [1], clause 9
9.7.3 Performance criteria; Voltage dips and interruptions	For a voltage dip corresponding to a reduction of the supply voltage of 30 % for 10 ms the performance criteria CP shall apply (see subclause 6.2).

Annex A (normative): Definitions of MESs within the scope of the present document

The present document covers types of MES equipment as set out below.

A.1 MESs operating within 1,6 GHz/2,4 GHz band

The present document applies to Mobile Earth Stations (MESs), with both transmit and receive capabilities for operation in a Satellite Personal Communication Network (S-PCN).

MES equipment may be handheld, portable or vehicle mounted. Unless otherwise stated in the present document, the present document only applies to the MES component of a multi-mode terminal.

The Mobile Satellite Service (MSS) frequency bands within which the MESs operate are given in the table A.1.

Table A.1: Mobile Satellite Service (MSS) frequency bands

Mode of operation	MSS frequency bands
MESs transmit	1 610 MHz - 1 626,5 MHz
MESs receive	1 613,8 MHz - 1 626,5 MHz 2 483,5 MHz - 2 500 MHz

A.2 MESs operating within the 1,5 GHz/1,6 GHz

The present document applies to Mobile Earth Stations (MESs), with both transmit and receive capabilities for operation in a Satellite Personal Communication Network (S-PCN).

MES equipment may be portable, vehicle mounted or fixed. Unless otherwise stated in the present document, the present document only applies to the MES component of a multi-mode terminal.

The Mobile Satellite Service (MSS) frequency bands within which the MESs operate are given in the table A.2.

Table A.2: Mobile Satellite Service (MSS) frequency bands

Mode of operation	MSS frequency bands
MESs transmit	1 626,5 MHz to 1 645,5 MHz
	1 646,5 MHz to 1 660,5 MHz
MESs receive	1 525 MHz to 1 544 MHz
	1 545 MHz to 1 559 MHz

A.3 MESs operating within 2,0 GHz band

The present document applies to Mobile Earth Stations (MESs), with both transmit and receive capabilities for operation in a Satellite Personal Communication Network (S-PCN).

MES equipment may be handheld, portable or vehicle mounted. Unless otherwise stated in the present document, the present document only applies to the MES component of a multi-mode terminal.

The Mobile Satellite Service (MSS) frequency bands within which the MESs operate are given in the table A.3.

Table A.3: Mobile Satellite Service (MSS) frequency bands

Mode of operation	MSS frequency bands
MESs transmit	1 980 MHz - 2 010 MHz
MESs receive	2 170 MHz - 2 200 MHz

A.4 MESs operating below 1 GHz

The present document applies to Mobile Earth Stations (MESs), with both transmit and receive capabilities for operation in a Low Earth Orbits (LEO) Network providing Low Bit Rate Data Communications (LBRDC).

MES equipment may be handheld, portable or vehicle mounted.

The Mobile Satellite Service (MSS) frequency bands within which the MESs operate are given in the table A.4.

Table A.4: Mobile Satellite Service (MSS) frequency bands

Mode of operation	MSS frequency bands
MESs transmit	148 MHz to 150,05 MHz 235 MHz to 322 MHz 335,4 MHz to 399,9 MHz 399,9 MHz to 400,05 MHz
MESs receive	137 MHz to 138 MHz 235 MHz to 322 MHz 335,4 MHz to 399,9 MHz 400,15 MHz to 401 MHz

A.5 MESs operating in the 11/12/14 GHz frequency bands

The present document applies to Mobile Earth Stations (MESs), transmitting data via geostationary satellites.

MES equipment may be vehicle mounted or portable.

The frequency bands within which the MESs operate are given in the table A.5.

Table A.5: Frequency bands

Mode of operation	MSS frequency bands
MESs transmit	14,00 GHz to 14,25 GHz
MESs receive	10,70 GHz to 11,70 GHz 12,50 GHz to 12,75 GHz

Bibliography

The following material, though not specifically referenced in the main body of the present document, gives supporting information.

ETSI EN 301 426: "Satellite Earth Stations and Systems (SES); Harmonized EN for Low data rate Land Mobile satellite Earth Stations (LMES) operating in the 1,5/1,6 GHz frequency bands covering essential requirements under Article 3.2 of the R&TTE directive".

ETSI EN 301 427: "Satellite Earth Stations and Systems (SES); Harmonized EN for Low data rate Land Mobile satellite Earth Stations (LMES) operating in the 11/12/14 GHz frequency bands covering essential requirements under article 3.2 of the R&TTE directive".

ETSI EN 301 441: "Satellite Earth Stations and Systems (SES); Harmonized EN for Mobile Earth Stations (MESs), including handheld earth stations, for Satellite Personal Communications Networks (S-PCN) in the 1,6/2,4 GHz bands under the Mobile Satellite Service (MSS) covering essential requirements under Article 3.2 of the R&TTE directive".

ETSI EN 301 442: "Satellite Earth Stations and Systems (SES); Harmonized EN for Mobile Earth Stations (MESs), including handheld earth stations, for Satellite Personal Communications Networks (S-PCN) in the 2,0 GHz bands under the Mobile Satellite Service (MSS) covering essential requirements under Article 3.2 of the R&TTE directive".

ETSI EN 301 444: "Satellite Earth Stations and Systems (SES); Harmonized EN for Land Mobile Earth Stations (LMES) operating in the 1,5 GHz and 1,6 GHz bands providing voice and/or data communications covering essential requirements under Article 3.2 of the R&TTE directive".

ETSI EN 301 721: "Satellite Earth Stations and Systems (SES); Harmonized EN for Mobile Earth Stations (MES) providing Low Bit Rate Data Communications (LBRDC) using Low Earth Orbiting (LEO) satellites operating below 1 GHz covering essential requirements under Article 3.2 of the R&TTE directive".

ETSI EN 301 681: "Satellite Personal Communications Networks (S-PCN); Mobile Earth Stations (MESs), including handheld earth stations, for S-PCN in the 1,5/1,6 GHz bands, providing voice and/or data communications under the Mobile Satellite Service (MSS)".

History

Document history		
V1.1.1	July 2000	One-step Approval Procedure OAP 20001117: 2000-07-19 to 2000-11-17
V1.1.1	December 2000	Publication