

Final draft **ETSI EN 301 489-18** V1.3.1 (2002-04)

Candidate Harmonized European Standard (Telecommunications series)

**ElectroMagnetic compatibility
and Radio spectrum Matters (ERM);
ElectroMagnetic Compatibility (EMC)
standard for radio equipment and services;
Part 18: Specific conditions for
Terrestrial Trunked Radio (TETRA) equipment**



Reference

REN/ERM-EMC-230-18

Keywords

EMC, radio, regulation, TETRA

ETSI

650 Route des Lucioles
F-06921 Sophia Antipolis Cedex - FRANCE

Tel.: +33 4 92 94 42 00 Fax: +33 4 93 65 47 16

Siret N° 348 623 562 00017 - NAF 742 C
Association à but non lucratif enregistrée à la
Sous-Préfecture de Grasse (06) N° 7803/88

Important notice

Individual copies of the present document can be downloaded from:

<http://www.etsi.org>

The present document may be made available in more than one electronic version or in print. In any case of existing or perceived difference in contents between such versions, the reference version is the Portable Document Format (PDF). In case of dispute, the reference shall be the printing on ETSI printers of the PDF version kept on a specific network drive within ETSI Secretariat.

Users of the present document should be aware that the document may be subject to revision or change of status. Information on the current status of this and other ETSI documents is available at

<http://portal.etsi.org/tb/status/status.asp>

If you find errors in the present document, send your comment to:

editor@etsi.fr

Copyright Notification

No part may be reproduced except as authorized by written permission.
The copyright and the foregoing restriction extend to reproduction in all media.

© European Telecommunications Standards Institute 2002.
All rights reserved.

DECTTM, **PLUGTESTS**TM and **UMTS**TM are Trade Marks of ETSI registered for the benefit of its Members.
TIPHONTM and the **TIPHON logo** are Trade Marks currently being registered by ETSI for the benefit of its Members.
3GPPTM is a Trade Mark of ETSI registered for the benefit of its Members and of the 3GPP Organizational Partners.

Contents

Intellectual Property Rights	5
Foreword.....	5
1 Scope	6
2 References	6
3 Definitions and abbreviations.....	7
3.1 Definitions	7
3.2 Abbreviations	7
4 Test conditions	8
4.1 General	8
4.2 Arrangements for test signals	8
4.2.1 Arrangements for wanted signals at the input of the transmitter	8
4.2.2 Arrangements for wanted signals at the output of the transmitter	8
4.2.3 Arrangements for wanted signals at the input of the receiver.....	8
4.2.4 Arrangements for wanted signals at the output of the receiver.....	8
4.2.5 Arrangements for testing a transmitter and a receiver together (as a system).....	8
4.3 RF exclusion band of radio communications equipment.....	8
4.3.1 Receiver and receivers of transceivers exclusion band.....	9
4.3.2 Transmitter exclusion band.....	9
4.4 Narrow band responses of receivers.....	9
4.5 Normal test modulation	9
5 Performance assessment.....	10
5.1 General	10
5.2 Equipment which supports circuit mode traffic transmission	10
5.3 Equipment which does not provide a continuous communication link	10
5.4 Ancillary equipment	10
5.5 Equipment classification	10
5.6 Performance assessment of equipment providing an audio path.....	10
5.6.1 Assessment of audio path using the audio breakthrough method	10
5.6.2 Assessment of audio path using the audio distortion method	12
6 Performance criteria	12
6.1 Performance criteria for Continuous phenomena applied to transmitters.....	12
6.1.1 Audio test criteria	13
6.1.1.1 Audio breakthrough requirement	13
6.1.1.2 Audio distortion requirement:	13
6.1.2 Non-audio test criteria	13
6.2 Performance criteria for transient phenomena applied to transmitters	13
6.3 Performance criteria for continuous phenomena applied to receivers.....	13
6.3.1 Audio test criteria	14
6.3.2 Non-audio test criteria	14
6.4 Performance criteria for Transient phenomena applied to Receivers.....	14
7 Applicability overview	14
7.1 Emission.....	14
7.1.1 General.....	14
7.1.2 Special conditions.....	14
7.2 Immunity	15
7.2.1 General.....	15
7.2.2 Special conditions.....	15
Annex A (informative): Examples of radio equipment in the scope of the present document	16
A.1 Mobile, base station, and portable equipment of TERrestrial Trunked Radio (TETRA) equipment	16
Annex B (informative): The EN title in the official languages	17

History18

Intellectual Property Rights

IPRs essential or potentially essential to the present document may have been declared to ETSI. The information pertaining to these essential IPRs, if any, is publicly available for **ETSI members and non-members**, and can be found in ETSI SR 000 314: "*Intellectual Property Rights (IPRs); Essential, or potentially Essential, IPRs notified to ETSI in respect of ETSI standards*", which is available from the ETSI Secretariat. Latest updates are available on the ETSI Web server (<http://webapp.etsi.org/IPR/home.asp>).

Pursuant to the ETSI IPR Policy, no investigation, including IPR searches, has been carried out by ETSI. No guarantee can be given as to the existence of other IPRs not referenced in ETSI SR 000 314 (or the updates on the ETSI Web server) which are, or may be, or may become, essential to the present document.

Foreword

This Candidate Harmonized European Standard (Telecommunications series) has been produced by ETSI Technical Committee Electromagnetic compatibility and Radio spectrum Matters (ERM), and is now submitted for the ETSI standards One-step Approval Procedure.

The present document has been produced by ETSI in response to a mandate from the European Commission issued under Council Directive 98/34/EC [10] (as amended) laying down a procedure for the provision of information in the field of technical standards and regulations.

The present document is intended to become a Harmonized Standard, the reference of which will be published in the Official Journal of the European Communities referencing the Council Directive on the approximation of the laws of the Member States relating to electromagnetic compatibility ("the EMC Directive") (89/336/EEC [3] as amended) and Directive 1999/5/EC of the European Parliament and of the Council of 9 March 1999 on radio equipment and telecommunications terminal equipment and the mutual recognition of their conformity ("the R&TTE Directive" [2]).

The present document is part 18 of a multi-part deliverable. Full details of the entire series can be found in part 1 [1].

Proposed national transposition dates	
Date of latest announcement of this EN (doa):	3 months after ETSI publication
Date of latest publication of new National Standard or endorsement of this EN (dop/e):	6 months after doa
Date of withdrawal of any conflicting National Standard (dow):	18 months after doa

1 Scope

The present document, together with EN 301 489-1 [1], covers the assessment of TERrestrial Trunked Radio (TETRA) radiocommunications and ancillary equipment in respect of ElectroMagnetic Compatibility (EMC).

Technical specifications related to the antenna port and emissions from the enclosure port of radio equipment are not included in the present document. Such technical specifications are found in the relevant product standards for the effective use of the radio spectrum.

The present document specifies the applicable test conditions, performance assessment and performance criteria for TETRA equipment, and associated ancillary equipment.

Examples of equipment covered by the present document are given in annex A.

In case of differences (for instance concerning special conditions, definitions, abbreviations) between the present document and EN 301 489-1 [1], the provisions of the present document take precedence.

The environmental classification and the emission and immunity requirements used in the present document are as stated in EN 301 489-1 [1], except for any special conditions included in the present document.

2 References

The following documents contain provisions which, through reference in this text, constitute provisions of the present document.

- References are either specific (identified by date of publication and/or edition number or version number) or non-specific.
- For a specific reference, subsequent revisions do not apply.
- For a non-specific reference, the latest version applies.

- [1] ETSI EN 301 489-1: "Electromagnetic compatibility and Radio spectrum Matters (ERM); ElectroMagnetic Compatibility (EMC) standard for radio equipment and services; Part 1: Common technical requirements".
- [2] Directive 1999/5/EC of the European Parliament and of the Council of 9 March 1999 on radio equipment and telecommunications terminal equipment and the mutual recognition of their conformity (R&TTE Directive).
- [3] Council Directive 89/336/EEC of 3 May 1989 on the approximation of the laws of the Member States relating to electromagnetic compatibility (EMC Directive).
- [4] ETSI EN 300 394-1: "Terrestrial Trunked Radio (TETRA); Conformance testing specification; Part 1: Radio".
- [5] ITU-T Recommendation O.153: "Basic parameters for the measurement of error performance at bit rates below the primary rate".
- [6] ETSI ETS 300 395-2 (1995): "Terrestrial Trunked Radio (TETRA); Speech codec for full-rate traffic channel; Part 2: TETRA codec".
- [7] ETSI EN 300 392-2: "Terrestrial Trunked Radio (TETRA); Voice plus Data (V+D); Part 2: Air Interface (AI)".
- [8] ETSI EN 300 396-2: "Terrestrial Trunked Radio (TETRA); Technical requirements for Direct Mode Operation (DMO); Part 2: Radio aspects".
- [9] ETSI ETS 300 393-2: "Terrestrial Trunked Radio (TETRA); Packet Data Optimized (PDO); Part 2: Air Interface (AI)".

- [10] Directive 98/34/EC of the European Parliament and of the Council of 22 June 1998 laying down a procedure for the provision of information in the field of technical standards and regulations.

3 Definitions and abbreviations

3.1 Definitions

For the purposes of the present document, the terms and definitions given in EN 301 489-1 [1] and the following apply:

ancillary equipment: equipment (apparatus), used in connection with a receiver or transmitter

NOTE: It is considered as an ancillary equipment (apparatus) if:

- the equipment is intended for use in conjunction with a receiver or transmitter to provide additional operational and/or control features to the radio equipment, (e.g. to extend control to another position or location); and
- the equipment cannot be used on a stand alone basis to provide user functions independently of a receiver or transmitter; and
- the receiver or transmitter to which it is connected, is capable of providing some intended operation such as transmitting and/or receiving without the ancillary equipment (i.e. it is not a sub-unit of the main equipment essential to the main equipment basic functions).

Infrastructure and control equipment intended to provide the required data and communication link establishment shall also be considered as ancillary equipment for the purposes of the present document.

equipment which is capable of speech operation: equipment that contains, or can be directly connected to a microphone and/or loudspeaker or earpiece, or which includes analogue audio signal interfaces

non-speech equipment: equipment that does not have an audio input or output capability either built in or via audio signal interfaces

NOTE: This category includes data only equipment, both base stations and terminals, and also (for example) V+D and PDO base stations and DMO repeaters which do not include any direct analogue audio capability.

3.2 Abbreviations

For the purposes of the present document, the abbreviations given in EN 300 392-2 [7] and the following apply:

BER	Bit Error Ratio
DMO	Direct Mode Operation
EMC	ElectroMagnetic Compatibility
ERP	Ear Reference Point
EUT	Equipment Under Test
MER	Message Error Ratio
MRP	Mouth Reference Point
PDO	Packet Data Optimized
SPL	Sound Pressure Level
TETRA	TErrestrial TRunked RAdio
V+D	Voice plus Data

4 Test conditions

4.1 General

For the purposes of the present document, the test conditions of EN 301 489-1 [1], clause 4, shall apply as appropriate. Further product related test conditions for radio equipment are specified in the present document.

The equipment shall be tested under normal test conditions as specified in EN 300 394-1 [4].

4.2 Arrangements for test signals

The provisions of EN 301 489-1 [1], clause 4.2 shall apply.

4.2.1 Arrangements for wanted signals at the input of the transmitter

The provisions of EN 301 489-1 [1], clause 4.2.1 shall apply.

4.2.2 Arrangements for wanted signals at the output of the transmitter

The provisions of EN 301 489-1 [1], clause 4.2.2 shall apply with the following modification.

For equipment under test which can support Direct Mode Operation (DMO), a TETRA transceiver may form part of the measuring system. For V+D and PDO equipment a base station or a mobile/portable may form part of the measuring system.

4.2.3 Arrangements for wanted signals at the input of the receiver

The provisions of EN 301 489-1 [1], clause 4.2.3 shall apply with the following modification.

For equipment under test which can support Direct Mode Operation (DMO) a TETRA transceiver may form part of the measuring system. For V+D and PDO equipment a base station or a mobile/portable may form part of the measuring system.

4.2.4 Arrangements for wanted signals at the output of the receiver

The provisions of EN 301 489-1 [1], clause 4.2.4 shall apply with the following modification.

The TTCI interface defined in EN 300 394-1 [4] annex C or the RF loopback method defined in EN 300 394-1 [4] annex D may be applied, it shall be agreed with the test house and the manufacturer which method to apply.

4.2.5 Arrangements for testing a transmitter and a receiver together (as a system)

The provisions of EN 301 489-1 [1], clause 4.2.5 shall apply.

4.3 RF exclusion band of radio communications equipment

The provisions of EN 301 489-1 [1], clause 4.3 shall apply with the following modification.

For transceivers and equipment operated in a duplex mode both exclusions bands detailed in clauses 4.3.1 and 4.3.2 apply simultaneously.

4.3.1 Receiver and receivers of transceivers exclusion band

The exclusion band for receivers and receivers of transceivers is the frequency range determined by the switching range, as declared by the manufacturer, extended as follows:

- the lower frequency of the exclusion band is the lower frequency of the switching range, minus 5 % of the centre frequency of the switching range, or minus 10 MHz, whichever will result in the lowest frequency;
- the upper frequency of the exclusion band is the upper frequency of the switching range, plus 5 % of the centre frequency of the switching range, or plus 10 MHz, which ever will result in the highest frequency.

The switching range is the maximum frequency range over which the receiver can be operated without reprogramming or realignment.

4.3.2 Transmitter exclusion band

The exclusion band for transmitters extends ± 50 kHz from the nominal operating frequency of the transmitter.

4.4 Narrow band responses of receivers

The provision of EN 301 489-1 [1], clause 4.4 shall apply with the following modification.

For the purpose of the present document, in the absence of a narrow IF filter bandwidth declared by the manufacturer, the IF bandwidth shall be taken as 25 kHz.

4.5 Normal test modulation

The receiver wanted input signal shall be set to a frequency near to the middle of the operating band of the receiver modulated with one of the test signals listed below, the transmitter shall be set to a frequency near to the middle of the operating band of the transmitter modulated with one of the test signals listed below:

- for equipment capable of speech operation, a speech traffic channel (TETRA TCH/S) in accordance with ETS 300 395-2 [6] representing a 1 020 Hz tone at a level of 17 dB below peak level;
- for non-speech V+D or DMO equipment, a TCH/7.2 test signal in accordance with EN 300 392-2 [7] or EN 300 396-2 [8] or EN 300 394-1 [4];
- for non-speech V+D or DMO equipment, a SCH/F test signal in accordance with EN 300 392-2 [7] or EN 300 396-2 [8] or EN 300 394-1 [4];
- for non-speech PDO equipment, a NBCH test signal in accordance with ETS 300 393-2 [9] or EN 300 394-1 [4];
- for equipment capable of speech operation speech traffic channel (TETRA TCH/S) in accordance with ETS 300 395-2 [6] representing silence;
- for speech and/or data equipment connected to ancillary equipment intended for data operation, or connected to ancillary equipment which can be directly connected to a data application, the method of BER or MER measurement shall be agreed between the test house and the manufacturer.

The manufacturer may have to supply the test modulation/demodulation equipment.

The test signal generator (modulation) shall produce a continuous stream of data or messages where the data or message content is a pseudorandom sequence with a length of 511 bits in accordance with ITU-T Recommendation O.153 [5].

The test signal receiver (demodulator) shall produce a readout of BER/MER of a continuous data/message stream.

5 Performance assessment

5.1 General

The provision of EN 301 489-1 [1], clause 5.1 shall apply.

5.2 Equipment which supports circuit mode traffic transmission

The provision of EN 301 489-1 [1], clause 5.2 shall apply with the following modification.

The test arrangement and signals given in clause 4 apply to radio equipment, or a combination of radio equipment and ancillary equipment, which permits the establishment and maintenance of a circuit mode TCH7.2 or TCH/S channel in accordance with EN 300 392-2 [7] or EN 300 394-1 [4].

5.3 Equipment which does not provide a continuous communication link

The provisions of EN 301 489-1 [1], clause 5.3 do not apply.

5.4 Ancillary equipment

The provision of EN 301 489-1 [1], clause 5.4 shall apply.

5.5 Equipment classification

The provision of EN 301 489-1 [1], clause 5.5 shall apply.

5.6 Performance assessment of equipment providing an audio path

The audio performance shall be evaluated using either the audio breakthrough method described in clause 5.6.1 or the audio distortion method described in clause 5.6.2.

5.6.1 Assessment of audio path using the audio breakthrough method

This test only applies to equipment, which contains audio capability. The audio paths shall be enabled.

A communication link shall be set up with a suitable TETRA transceiver system simulator, or test set (hereafter called "the test system"). The wanted RF signals to be applied should be agreed between the test house and the manufacturer.

When the EUT is required to be in the transmit/receive mode, the following conditions shall be met:

- the EUT shall be set to operate at maximum transmit power;
- prior to the test sequence, the reference level of the speech output signal on both the downlink and uplink shall be recorded on the test instrumentation, as shown in figure 2. The reference level shall be equivalent to 0 dBPa at 1 020 Hz at the Ear Reference Point (ERP), or +5,0 dBPa at the loudspeaker for the downlink and -5 dBPa at 1 020 Hz at the Mouth Reference Point (MRP), or the microphone for the uplink. The nominal acoustic test levels may need to be adapted for different types of TETRA equipment and for different acoustic test arrangements;
- the level of the output signal from the EUT's downlink speech channel at the mobile or portable's ear piece shall be assessed by measuring the Sound Pressure Level (SPL) as shown in figure 1;

- the level of the recovered audio output signal of the test system from the EUT's uplink speech channel shall be measured. Pick up of extraneous background noise by the EUT's microphone shall be minimized.

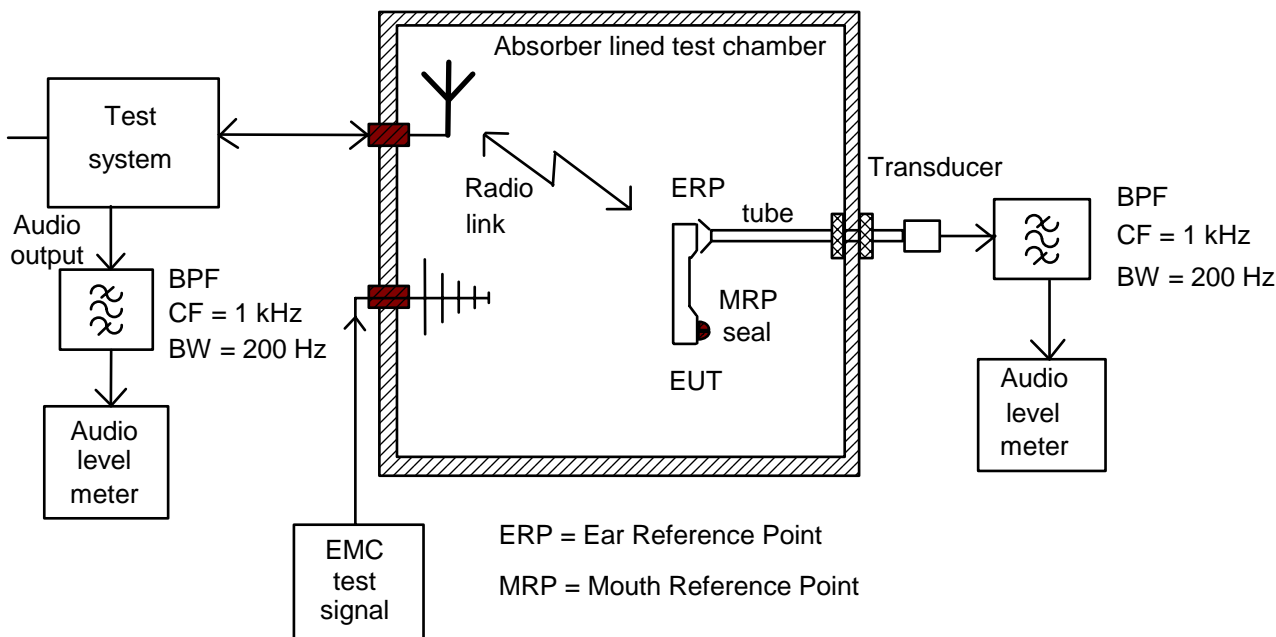

NOTE: In the case of a mobile equipment the ERP may be the loudspeaker, and the MRP the microphone.

Figure 1: Audio breakthrough measurement, test set-up

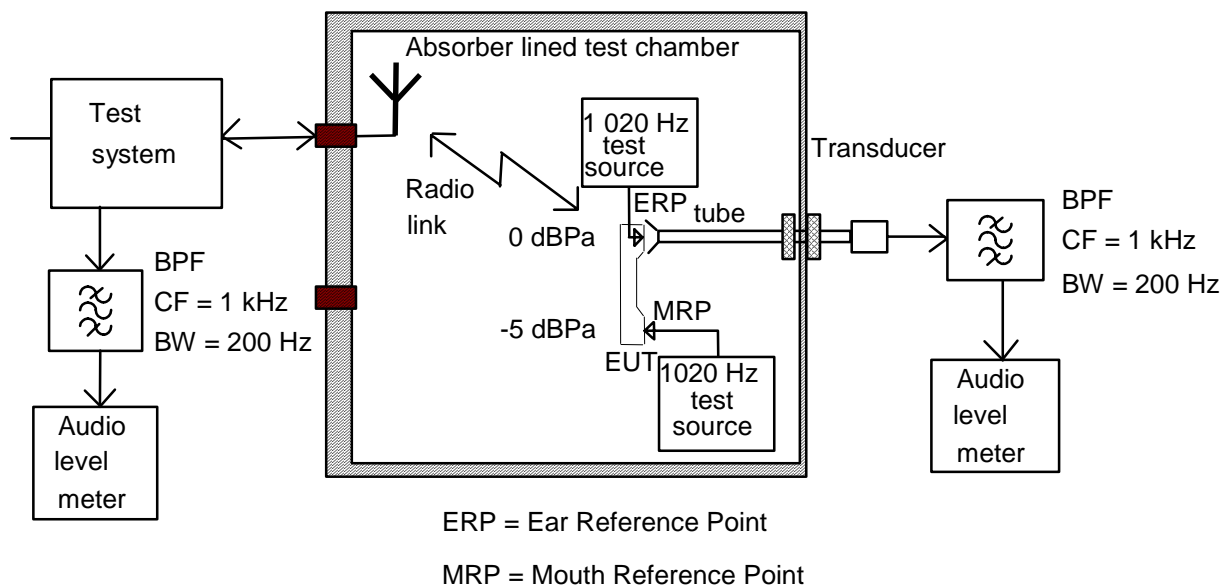

NOTE 1: The EUT is in position during calibration of the uplink, but not during calibration of the downlink.

NOTE 2: Where the EUT has a loudspeaker the reference level shall be equivalent to +5,0 dBPa at 1 020 Hz.

Figure 2: Audio breakthrough measurement, calibration set-up

5.6.2 Assessment of audio path using the audio distortion method

This test only applies to equipment, which contains audio capability. The audio paths shall be enabled.

A communication link loop-back shall be set up through a suitable TETRA test system. The wanted RF signals to be applied should be agreed between the test house and the manufacturer.

- the EUT shall be set to operate at maximum transmit power;
- a link between the EUT and the test system is established. In the test system the received uplink signal from the EUT is looped back and returned to the EUT as a downlink signal. The loopback in the test system should be done keeping the looped signal in a digital format or in a way that the signal to be looped is left unchanged;
- a 1 020 Hz signal, at a level within the dynamic range of the microphone audio circuit, is applied at the Mouth Reference Point (MRP).

The audio signal is, after loopback in the test system, picked up at the Ear Reference Point (ERP) by an audio transducer provided with a non metallic acoustic tube. The transducer signal is feed to an audio distortion analyser located outside the test environment.

Pick up of extraneous background noise by the EUT's microphone or by the transducer at the ERP shall be minimized.

6 Performance criteria

The equipment shall meet the minimum performance criteria as specified in clauses 6.1, 6.2, 6.3 and 6.4.

The establishment of the communication link at the start of the test, its maintenance and the assessment of the recovered signal are used as the performance criteria for the evaluation of the primary functions of the equipment during and after the test.

A portable equipment powered by the battery in the vehicle shall fulfil the applicable requirements in EN 301 489-1 [1] for vehicular mobile equipment.

A portable or mobile equipment powered by AC mains shall fulfil the applicable requirements in EN 301 489-1 [1] for base station equipment, although the tests performed are only those applicable to the input/output arrangements of the equipment, the performance criteria will remain as the origin class for the equipment.

If an equipment is of a specialized nature and the performance criteria specified below are not appropriate the manufacturer shall declare a substituted specification for an acceptable performance level or performance degradation as required by the present document. The performance specification shall be included in the test report and the product description and documentation.

The performance criteria specified by the manufacturer shall give the same degree of immunity protection as called for in the following clauses.

6.1 Performance criteria for Continuous phenomena applied to transmitters

Equipment that is capable of speech operation shall meet the audio test criteria in clause 6.1.1.

Non-speech equipment shall meet the performance criteria of clause 6.1.2.

At the conclusion of the test the EUT shall operate as intended with no loss of user control functions or stored data, and the communication link shall have been maintained during the test.

Where the EUT is a transmitter only, tests shall be repeated with the EUT in standby mode to ensure that unintentional transmission does not occur.

6.1.1 Audio test criteria

Dependent on the selected audio test procedure, the EUT shall comply with the audio breakthrough and audio link requirement (see clause 6.1.1.1) or the audio distortion requirement (see clause 6.1.1.2).

6.1.1.1 Audio breakthrough requirement

For details see clause 5.6.1. During the immunity tests, the observed uplink and downlink speech output levels shall be at least 35 dB less than the previously recorded reference level, when measured through an audio band pass filter of 200 Hz width, centred on 1 kHz.

NOTE: When there is a high level of background noise the filter bandwidth can be reduced down to a minimum of 40 Hz.

Audio link requirement:

During the audio breakthrough test the speech channel shall maintain its functionality and shall not be accidentally muted because of exposure to EMC phenomena. The test may be made either as a separate test or integrated in the audio breakthrough test by adding at each testpoint an extra measurement of the transfer function of an imposed audio signal. The precise implementation method is left to the test laboratory.

6.1.1.2 Audio distortion requirement:

For details see clause 5.6.2. The distortion of the audio signal shall be measured during each individual in the test sequence and shall not exceed 15 % measured in a post detection bandwidth determined by a first order band pass filter with a 3 dB bandwidth of 300 Hz to 3 kHz, without the use of psophometric weighting filter.

6.1.2 Non-audio test criteria

For non voice equipment the performance criteria can be either:

- the BER of the test signal shall not exceed 10^{-2} (TCH7.2 for V+D or DMO) during the test sequence; or
- the Message Erasure Rate (MER) (SCH/F for V+D, NBCH for PDO) shall not exceed 20 %, or 80 % of the transmitted messages shall be received correctly.

6.2 Performance criteria for transient phenomena applied to transmitters

At the conclusion of each exposure the EUT shall operate with no user noticeable loss of the communication link.

At the conclusion of the total test comprising the series of individual exposures the EUT shall operate as intended with no loss of user control functions or stored data, as declared by the manufacturer, and the communication link shall have been maintained.

Where the EUT is a transmitter only, tests shall be repeated with the EUT in standby mode to ensure that unintentional transmission does not occur.

6.3 Performance criteria for continuous phenomena applied to receivers

Equipment that is capable of speech operation shall meet the audio test criteria in clause 6.3.1.

Non-speech equipment shall meet the performance criteria of clause 6.3.2.

At the conclusion of the test the EUT shall operate as intended with no loss of user control functions or stored data, and the communication link shall have been maintained during the test.

Where the EUT is a transceiver only, tests shall be repeated with the EUT in standby mode to ensure that unintentional transmission does not occur.

6.3.1 Audio test criteria

Audio breakthrough test:

For details see clause 5.6. During the immunity tests, the observed uplink and downlink speech output levels shall be at least 35 dB less than the previously recorded reference level, when measured through an audio band pass filter of 200 Hz width, centred on 1 kHz.

NOTE: When there is a high level of background noise the filter bandwidth can be reduced down to a minimum of 40 Hz.

Audio link test:

During the audio breakthrough test the speech channel shall maintain its functionality and shall not be accidentally muted because of exposure to EMC phenomena. The test may be made either as a separate test or integrated in the audio breakthrough test by adding at each testpoint an extra measurement of the transfer function of an imposed audio signal. The precise implementation method is left to the test laboratory.

6.3.2 Non-audio test criteria

For non voice equipment the performance criteria can be either:

- the BER of the test signal shall not exceed 10^{-2} (TCH7.2 for V+D or DMO) during the test sequence; or
- the Message Erasure Rate (MER) (SCH/F for V+D, NBCH for PDO) shall not exceed 20 %, or 80 % of the transmitted messages shall be received correctly.

6.4 Performance criteria for Transient phenomena applied to Receivers

At the conclusion of each exposure the EUT shall operate with no user noticeable loss of the communication link.

At the conclusion of the total test comprising the series of individual exposures the EUT shall operate as intended with no loss of user control functions or stored data, as declared by the manufacturer, and the communication link shall have been maintained.

Where the EUT is a transceiver, under no circumstances shall the transmitter operate unintentionally during the test.

7 Applicability overview

7.1 Emission

7.1.1 General

EN 301 489-1 [1], table 2, contains the applicability of EMC emission measurements to the relevant ports of radio and/or associated ancillary equipment.

7.1.2 Special conditions

No special conditions shall apply to radio equipment in the scope of the present document.

7.2 Immunity

7.2.1 General

EN 301 489-1 [1], table 3, contains the applicability of EMC immunity measurements to the relevant ports of radio and/or associated ancillary equipment.

7.2.2 Special conditions

The following special conditions set out in table 1, relate to the immunity test methods and performance criteria used in EN 301 489-1 [1], clause 9.

Table 1: Special conditions for EMC immunity tests

Reference to clauses in EN 301 489-1 [1]	Special product-related conditions, additional to or modifying the test conditions in EN 301 489-1 [1], clause 9
9.2.2: Test method; Radio frequency electromagnetic field	<ul style="list-style-type: none"> - the test signal shall be amplitude modulated to a depth of 80 % by a sinusoidal audio signal of 1 020 Hz; - for transmitters in transceivers with a non-continuous duty cycle the stepped frequency increments may be 10 % of the momentary frequency; - the test shall be carried out on one surface. The surface selected to face the source of the interference signal shall be the one anticipated by the test house to be the most susceptible. The selected surface shall be recorded in the test report.
9.5.2: Test method Radio frequency, common mode	<ul style="list-style-type: none"> - the test signal shall be amplitude modulated to a depth of 80 % by a sinusoidal audio signal of 1 020 Hz; - for transmitters in transceivers with a non-continuous duty cycle the stepped frequency increments may be 500 kHz in the frequency range 150 kHz to 5 MHz and 10 % frequency increment of the momentary frequency in the frequency range 5 MHz to 80 MHz.

Annex A (informative): Examples of radio equipment in the scope of the present document

The present document covers types of TETRA equipment as set out below.

A.1 Mobile, base station, and portable equipment of TErrestrial Trunked Radio (TETRA) equipment

The present document applies to all TErrestrial Trunked Radio (TETRA) radio equipment. This includes the following categories of equipment:

- Mobile Station (MS);
- Base Station (BS);
- Direct Mode Mobile Station (DM-MS);
- Dual Watch Mobile Station (DW-MS);
- Direct Mode GATEway (DM-GATE);
- Direct Mode REPeater (DM-REP);
- Direct Mode REPeater/GATEway (DM-REP/GATE);
- Trunked MDe REPeater (TMO-REP);
- portable equipment of TErrestrial Trunked Radio (TETRA) radiocommunications systems.

Annex B (informative): The EN title in the official languages

Language	EN title
Danish	
Dutch	
English	ElectroMagnetic compatibility and Radio spectrum Matters (ERM); ElectroMagnetic Compatibility (EMC) standard for radio equipment and services; Part 18: Specific conditions for Terrestrial Trunked Radio (TETRA) equipment
Finnish	
French	
German	
Greek	
Italian	
Portuguese	
Spanish	
Swedish	

History

Document history		
V1.1.1	September 2000	Publication
V1.2.1	November 2001	Publication
V1.3.1	April 2002	One-step Approval Procedure OAP 20020809: 2002-04-10 to 2002-08-09