

Draft **ETSI EN 301 489-16** V1.1.1 (2000-05)

Candidate Harmonized European Standard (Telecommunications series)

**ElectroMagnetic compatibility
and Radio spectrum Matters (ERM);
ElectroMagnetic Compatibility (EMC) standard
for radio equipment and services;
Part 16: Specific conditions for analogue cellular radio
communications equipment, mobile and portable**



Reference

DEN/ERM-EMC-219-16

Keywords

analogue, EMC, radio, regulation

ETSI

650 Route des Lucioles
F-06921 Sophia Antipolis Cedex - FRANCE

Tel.: +33 4 92 94 42 00 Fax: +33 4 93 65 47 16

Siret N° 348 623 562 00017 - NAF 742 C
Association à but non lucratif enregistrée à la
Sous-Préfecture de Grasse (06) N° 7803/88

Important notice

Individual copies of the present document can be downloaded from:

<http://www.etsi.org>

The present document may be made available in more than one electronic version or in print. In any case of existing or perceived difference in contents between such versions, the reference version is the Portable Document Format (PDF).

In case of dispute, the reference shall be the printing on ETSI printers of the PDF version kept on a specific network drive within ETSI Secretariat.

Users of the present document should be aware that the document may be subject to revision or change of status.

Information on the current status of this and other ETSI documents is available at <http://www.etsi.org/tb/status/>

If you find errors in the present document, send your comment to:

editor@etsi.fr

Copyright Notification

No part may be reproduced except as authorized by written permission.
The copyright and the foregoing restriction extend to reproduction in all media.

© European Telecommunications Standards Institute 2000.

All rights reserved.

Contents

Intellectual Property Rights	5
Foreword	5
1 Scope	7
2 References	7
3 Definitions and abbreviations	8
3.1 Definitions	8
3.2 Abbreviations	8
4 Test conditions	8
4.1 General	8
4.2 Arrangements for test signals	9
4.2.1 Arrangements for establishing a communications link.....	9
4.2.1.1 Calibration of audio levels	9
4.2.2 Arrangements for test signals at the input of the transmitter.....	10
4.2.3 Arrangements for test signals at the output of transmitters	10
4.2.4 Arrangements for test signals at the input of receivers	11
4.2.5 Arrangement for test signals at the output of receivers	11
4.2.6 Arrangements for testing the transmitter and receiver together	11
4.3 Exclusion bands.....	12
4.3.1 Receiver and duplex transceiver exclusion band	12
4.3.2 Transmitter exclusion band.....	12
4.4 Narrowband responses of receivers or receivers of duplex transceivers	12
4.5 Normal test modulation	12
5 Performance assessment.....	13
5.1 General	13
5.2 Equipment which can provide a communication link.....	13
5.3 Equipment which does not provide a communication link	13
5.4 Ancillary equipment	13
5.5 Equipment classification.....	13
6 Performance criteria	13
6.1 Performance criteria for Continuous phenomena applied to Transmitters (CT).....	14
6.2 Performance criteria for Transient phenomena applied to Transmitters (TT)	14
6.3 Performance criteria for Continuous phenomena applied to Receivers (CR)	15
6.4 Performance criteria for Transient phenomena applied to Receivers (TR)	15
7 Applicability overview tables	15
7.1 Emission.....	15
7.1.1 General.....	15
7.1.2 Special conditions.....	15
7.2 Immunity	15
7.2.1 General.....	15
7.2.2 Special conditions.....	15

Annex A (informative):	Examples of analogue cellular radio communications equipment in the scope of the present document	16
A.1	Mobile Radio Telephone equipment used in Net-C.....	16
A.2	Mobile Radio Telephone equipment used in the Nordic Mobile Telephone (NMT 450 and NMT 900) service	16
A.3	Mobile Radio Telephone equipment used in the Radiocom 2000 service (R 2000)	16
A.4	Mobile Radio Telephone equipment used in the Extended Total Access Communications System (ETACS) and in the Total Access Communications System (TACS).....	17
History	18

Intellectual Property Rights

IPRs essential or potentially essential to the present document may have been declared to ETSI. The information pertaining to these essential IPRs, if any, is publicly available for **ETSI members and non-members**, and can be found in SR 000 314: *"Intellectual Property Rights (IPRs); Essential, or potentially Essential, IPRs notified to ETSI in respect of ETSI standards"*, which is available from the ETSI Secretariat. Latest updates are available on the ETSI Web server (<http://www.etsi.org/ipr>).

Pursuant to the ETSI IPR Policy, no investigation, including IPR searches, has been carried out by ETSI. No guarantee can be given as to the existence of other IPRs not referenced in SR 000 314 (or the updates on the ETSI Web server) which are, or may be, or may become, essential to the present document.

Foreword

This Candidate Harmonized European Standard (Telecommunications series) has been produced by ETSI Technical Committee Electromagnetic compatibility and Radio spectrum Matters (ERM), and is now submitted for the ETSI standards One-step Approval Procedure.

The present document has been produced by ETSI in response to a mandate from the European Commission issued under the Council Directive 98/34/EC [1] (as amended) laying down a procedure for the provision of information in the field of technical standards and regulation.

The present document together, with EN 301 489-1 [1], is intended to become a Harmonized EMC Standard, the reference of which will be published in the Official Journal of the European Communities referencing the Council Directive on the approximation of the laws of the Member States relating to electromagnetic compatibility (the "EMC Directive" 89/336/EEC [3] as amended), and the Council Directive on the approximation of the laws of the Member States relating to radio equipment and telecommunications terminal equipment and the mutual recognition of their conformity (the "R&TTE Directive" 1999/5/EC [2]).

The present document is part 16 of a multi-part EN covering the ElectroMagnetic Compatibility and Radio Spectrum Matters (ERM); ElectroMagnetic Compatibility (EMC) standard for radio equipment and services, as identified below:

- Part 1: "Common technical requirements";
- Part 2: "Specific conditions for radio paging equipment";
- Part 3: "Specific conditions for Short-Range Devices (SRD) operating on frequencies between 9 kHz and 40 GHz";
- Part 4: "Specific conditions for fixed radio links and ancillary equipment and services";
- Part 5: "Specific conditions for Private land Mobile Radio (PMR) and ancillary equipment (speech and non-speech)";
- Part 6: "Specific conditions for Digital Enhanced Cordless Telecommunications (DECT) equipment";
- Part 7: "Specific conditions for mobile and portable radio and ancillary equipment of digital cellular radio telecommunications systems (GSM and DCS)";
- Part 8: "Specific requirements for GSM base stations";
- Part 9: "Specific conditions for wireless microphones and similar Radio Frequency (RF) audio link equipment";
- Part 10: "Specific conditions for First (CT1 and CT1+) and Second Generation Cordless Telephone (CT2) equipment";
- Part 11: "Specific conditions for FM broadcasting transmitters";
- Part 12: "Specific conditions for Earth Stations operated in the frequency ranges between 4 GHz and 30 GHz in the Fixed Satellite Service (FSS)";

Part 13: "Specific conditions for Citizens' Band (CB) radio and ancillary equipment (speech and non-speech)";

Part 15: "Specific conditions for commercially available amateur radio equipment";

Part 16: "Specific conditions for analogue cellular radio communications equipment, mobile and portable";

Part 17: "Specific requirements for Wideband data and HIPERLAN";

Part 18: "Specific requirements for Terrestrial Trunked Radio (TETRA)";

Part 19: "Specific conditions for Receive Only Mobile Earth Stations (ROMES) operating in the 1,5 GHz band providing data communications";

Part 20: "Specific conditions for Mobile Earth Stations (MES) used in the Mobile Satellite Services (MSS)";

Part 21: "Specific requirements for LEO mobile Earth Stations".

Part 22: "Specific requirements for VHF aeronautical mobile and fixed radios".

Proposed national transposition dates	
Date of latest announcement of this EN (doa):	3 months after ETSI publication
Date of latest publication of new National Standard or endorsement of this EN (dop/e):	6 months after doa
Date of withdrawal of any conflicting National Standard (dow):	36 months after doa

1 Scope

The present document, together with EN 301 489-1 [1], covers the assessment of analogue cellular radio communication equipment, mobile and portable and associated ancillary equipment, in respect of ElectroMagnetic Compatibility (EMC).

Technical specifications related to the antenna port and emissions from the enclosure port of analogue cellular radio communications equipment, mobile and portable equipment are not included in the present document. Such technical specifications are found in the relevant product standards for the effective use of the radio spectrum.

The present document specifies the applicable test conditions, performance assessment and performance criteria for analogue public cellular mobile and portable radio equipment for transmitting and receiving speech and/or data, and the associated ancillary equipment.

Examples of types analogue cellular radio communication equipment covered by the present document are given in annex A.

Base station equipment operating within network infrastructure is outside the scope of the present document. However, the present document does cover mobile and portable equipment that is intended to be operated in a fixed location while connected to the AC mains.

In case of differences (for instance concerning special conditions, definitions, abbreviations) between the present document and EN 301 489-1 [1], the provisions of the present document take precedence.

The environmental classification and the emission and immunity requirements used in the present document are as stated in EN 301 489-1 [1], except for any special conditions included in the present document.

2 References

The following documents contain provisions which, through reference in this text, constitute provisions of the present document.

- References are either specific (identified by date of publication, edition number, version number, etc.) or non-specific.
- For a specific reference, subsequent revisions do not apply.
- For a non-specific reference, subsequent revisions do apply.
- A non-specific reference to an ETS shall also be taken to refer to later versions published as an EN with the same number.

- [1] ETSI EN 301 489-1: "Electromagnetic compatibility and Radio spectrum Matters (ERM); ElectroMagnetic Compatibility (EMC) standard for radio equipment and services; Part 1: Common technical requirements".
- [2] Directive 1999/5/EC of the European Parliament and of the Council of 9 March 1999 on radio equipment and telecommunications equipment and the mutual recognition of their conformity.
- [3] Council Directive 89/336/EEC of 3 May 1989 on the approximation of the laws of the Member States relating to electromagnetic compatibility.
- [4] BAPT 211 ZV 08 (January 1995): "Zulassungsvorschrift für Funktelefoneräte im Netz C" (Type Approval Specification for Mobile Radio Telephone equipment used in Net-C).
- [5] NMT DOC 450-3 (1995): "Automatic Cellular Mobile Telephone System, Technical Specification for the Mobile Station".
- [6] NMT Doc 900-3 (1995): "Automatic Cellular Mobile Telephone System, Technical Specification for the Mobile Station".

- [7] R 2000 (1991): "Specification des stations mobiles radiocom 2000", Version 3 (Specification for Mobile Stations of Radiocom 2000).
- [8] PD 7005 (1996): "Essential requirements for terminal equipment intended for connection for connection to the extended total access communications system (ETACS)".
- [9] MPT 1324 Performance Specification (November 1996): "Angle modulated radio equipment for use at base and mobile stations in the public radiophone service operating in the 900 MHz frequency band".
- [10] BS 6940-1 (1990): "Total Access Communication System (TACS). Specification for performance requirements for mobile stations".
- [11] Directive 98/34/EC of the European Parliament and of the Council of 22 June 1998 laying down a procedure for the provision of information in the field of technical standards and regulations.

3 Definitions and abbreviations

3.1 Definitions

For the purposes of the present document, the definitions of EN 301 489-1 [1], clause 3, and the following apply:

idle mode: mode of operation of a receiver or a transceiver, where the Equipment Under Test (EUT) is powered, available for service and available to respond to a request to set up a call.

3.2 Abbreviations

For the purposes of the present document, the following abbreviations apply:

BPF	Band Pass Filter
DTX	Discontinuous Transmit
emf	electromotive force
ERP	Ear Reference Point
EUT	Equipment Under Test
MRP	Mouth Reference Point
RF	Radio Frequency
SPL	Sound Pressure Level

4 Test conditions

For the purposes of the present document, the test conditions of EN 301 489-1 [1], clause 4, shall apply as appropriate. Further product related test conditions for analogue cellular radio equipment, mobile and portable equipment are specified in the present document.

4.1 General

For emission and immunity, tests the test modulation, test arrangements, etc., as specified in the present document, subclauses 4.1 to 4.5 shall apply:

- where portable (handheld) equipment is provided with a detachable integral antenna, it shall be tested with the antenna fitted in a manner typical of normal intended use, unless specified otherwise in this present document;
- where the EUT employs audio companding in normal service, the unit shall have this function enabled for testing, if it is supported by the test system used to provide the communication link. Details of the methods used to establish the communications link shall be recorded in the test report;

- the test arrangements for transmitters and receivers are described separately for the sake of clarity. However, where possible the test of the transmitter section and receiver section of the EUT may be carried out simultaneously to reduce test time.

When the EUT is required to be in the idle mode, the test system shall simulate a base station. The EUT shall be in a state such that it is able to respond to requests to set up a call.

EXAMPLE: An ETACS mobile equipment is synchronized to the Forward Control Channel.

4.2 Arrangements for test signals

The provisions of EN 301 489-1 [1], subclause 4.2 shall apply.

4.2.1 Arrangements for establishing a communications link

The provisions of EN 301 489-1 [1], subclause 4.2.1 shall apply with the following modifications.

A communication link shall be set up with a suitable base station, system simulator, or production mobile tester (hereafter called "the test system"), which shall give an indication of the maintenance of the link.

For the immunity tests of duplex transceivers, the wanted input signal, coupled to the receiver, shall be modulated with normal test modulation, the transmitter shall be operated at its maximum rated output power and shall be modulated with normal test modulation, and a communication link shall be established.

4.2.1.1 Calibration of audio levels

A communication link shall be set up with a suitable base station, system simulator, or production mobile tester (hereafter called "the test system"), which shall give an indication of the maintenance of the link.

The test configuration shall be calibrated as follows:

- the EUT shall be set to operate at the rated maximum transmit power;
- prior to the test sequence, the level of the 1 kHz test source at the Mouth Reference Point (MRP) shall be adjusted to give the reference test frequency deviation. The demodulated audio level of the speech output signal on the uplink shall be recorded on the test instrumentation, as shown in figure 2. The audio feeding the MRP shall then be switched off. The level of the 1 kHz test source feeding the test system speech input on the downlink signal shall be adjusted to give the reference test frequency deviation. Set the EUT volume to provide nominal audio level if specified by the manufacturer. If no such level is specified, the centre volume step shall be used. The audio level at the Ear Reference Point (ERP) shall be recorded on the test instrumentation, as shown in figure 2. The 1 kHz test source shall then be switched off.

The test configuration shall be operated as follows:

- the level of the output signal from the Equipment Under Test's (EUT's) downlink speech channel at the mobile or portable shall be assessed by measuring the Sound Pressure Level (SPL) at the ERP as shown in figure 1;
- the level of the decoded output signal from the EUT's uplink speech channel at the analogue output of the test system shall be measured as shown in figure 1. Pick up of extraneous background noise by the EUT's microphone shall be minimized. An MRP seal may be used.

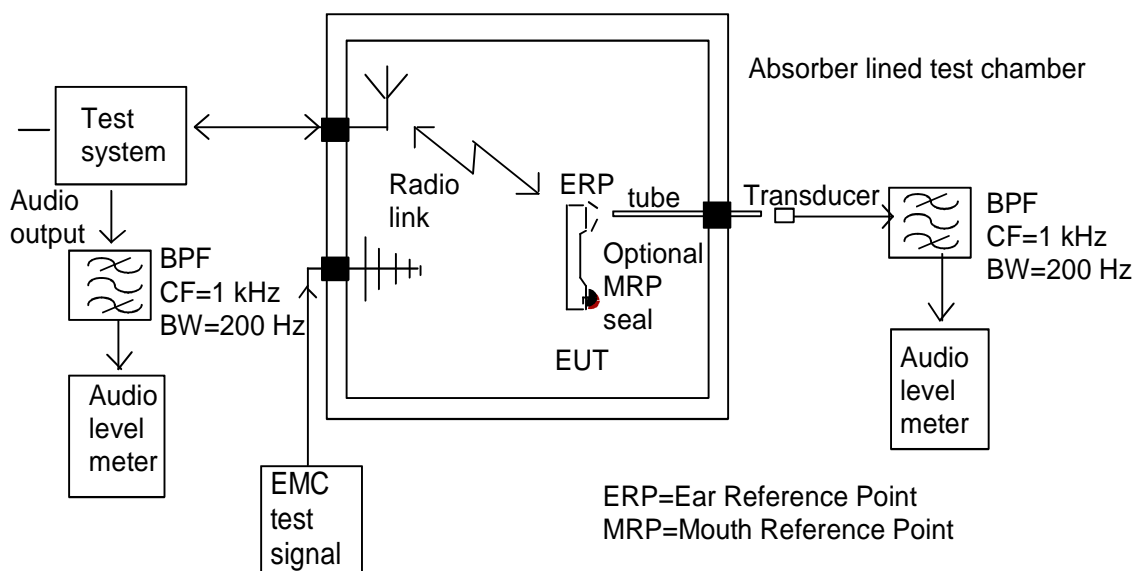
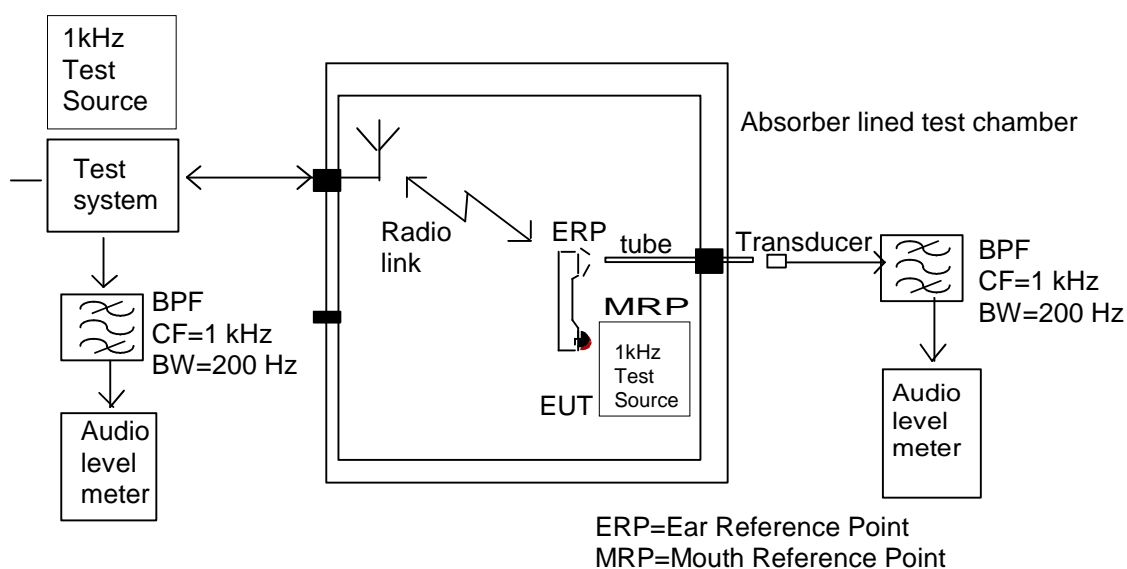

Figure 1: Audio breakthrough measurement, test set-up



NOTE: The 1 kHz MRP Test Source is in position during calibration of the uplink, but not during calibration of the downlink.

Figure 2: Audio breakthrough measurement, calibration set-up

4.2.2 Arrangements for test signals at the input of the transmitter

The provisions of EN 301 489-1 [1], subclause 4.2.2 shall apply with the following modifications.

When Discontinuous Transmit (DTX) is supported by the EUT, this feature shall be disabled for the duration of the test.

A communication link shall be set up between the EUT and the test system.

4.2.3 Arrangements for test signals at the output of transmitters

The provisions of EN 301 489-1 [1], subclause 4.2.2 shall apply with the following modifications.

The test system shall be located outside of the test environment.

Where the equipment incorporates an external 50 Ω RF antenna connector that is normally connected via a coaxial cable, then the wanted signal to establish a communication link shall be delivered from that connector by a coaxial cable. Adequate measures shall be taken to avoid the effect of the unwanted signal on the measuring equipment.

Where the equipment incorporates an external 50 Ω RF antenna connector but this port is not normally connected via a coaxial cable, then the wanted signal to establish a communication link shall be delivered from that connector by a coaxial cable. Adequate measures shall be taken to avoid the effect of unwanted currents on the external conductor of the coaxial cable at the point of entry to the equipment. Adequate measures shall also be taken to avoid the effect of the unwanted signal on the measuring equipment.

Where the equipment does not incorporate an external 50 Ω RF connector (integral antenna equipment), the wanted signal, to establish a communication link, shall be delivered from the equipment to an antenna located within the test environment. Adequate measures shall be taken to avoid the effect of the unwanted signal on the measuring equipment.

4.2.4 Arrangements for test signals at the input of receivers

The provisions of EN 301 489-1 [1], subclause 4.2.3 shall apply with the following modification.

The test system shall be located outside of the test environment.

Where the equipment incorporates an external 50 Ω RF antenna connector that is normally connected via a coaxial cable, then the wanted signal to establish a communication link shall be delivered to that connector by a coaxial cable. Adequate measures shall be taken to avoid the effect of the unwanted signal on the measuring equipment. The source of the wanted input signal shall be located outside of the test environment. The wanted input signal level shall set at a nominal value of 66 dB μ V electromotive force (emf) unless such level causes the EUT to autonomously lower its transmit power level. If such level causes the EUT to lower its transmit power, the wanted input signal level shall be decreased to a level where the EUT returns to its maximum transmit power but no lower than 40 dB above the EUT's rated receiver sensitivity level.

Where the equipment incorporates an external 50 Ω RF antenna connector, but this port is not normally connected via a coaxial cable, then the wanted signal to establish a communication link shall be delivered from that connector by a coaxial cable. Adequate measures shall be taken to avoid the effect of unwanted currents on the external conductor of the coaxial cable at the point of entry to the equipment. Adequate measures shall also be taken to avoid the effect of the unwanted signal on the measuring equipment. The source of the wanted input signal shall be located outside of the test environment. The wanted input signal level shall set at a nominal value of 66 dB μ V emf unless such level causes the EUT to autonomously lower its transmit power level. If such level causes the EUT to lower its transmit power, the wanted input signal level shall be decreased to a level where the EUT returns to its maximum transmit power but no lower than 40 dB above the EUT's rated receiver sensitivity level.

Where the equipment does not incorporate an external 50 Ω RF connector (integral antenna equipment), the wanted signal, to establish a communication link, shall be presented to the equipment from an antenna located within the test environment. The source of the wanted input signal shall be located outside of the test environment. The wanted input signal level shall set at a nominal value of 90 dB μ V/m unless such level causes the EUT to autonomously lower its transmit power level. If such level causes the EUT to lower its transmit power, wanted input signal level shall be decreased to a level where the EUT returns to its maximum transmit power but no lower than 40 dB above the EUT's rated receiver sensitivity level.

4.2.5 Arrangement for test signals at the output of receivers

The provisions of EN 301 489-1 [1], subclause 4.2.4 shall apply with the following modification.

The audio frequency output of the equipment may be coupled via a non-metallic acoustic tube to a suitable audio level meter outside of the test environment.

Other means of connecting the receiver output to a suitable audio level meter may be provided but shall be recorded in the test report. Precautions shall be taken to ensure that any effect on the test is minimized.

4.2.6 Arrangements for testing the transmitter and receiver together

The provision of EN 301 489-1 [1], subclause 4.2.5 shall apply with the following modification.

For the immunity tests of duplex transceivers, the wanted input signal, coupled to the receiver, shall be modulated with normal test modulation, the transmitter shall be operated at its maximum rated output power and shall be modulated with normal test modulation, and a communication link shall be established.

4.3 Exclusion bands

4.3.1 Receiver and duplex transceiver exclusion band

The exclusion band for receivers and the receivers of transceivers is the band of frequencies over which no radiated immunity tests are made.

The lower frequency of the exclusion band is the lower frequency of the receive band of the EUT -5 %.

The upper frequency of the exclusion band is the upper frequency of the receive band of the EUT +5 %.

4.3.2 Transmitter exclusion band

The exclusion band for transmitters extends three times the channel separation centred on the nominal operating frequency of the transmitter.

EXAMPLE: For ETACS, NMT450 and NMT900, the exclusion band is 75 kHz wide.

4.4 Narrowband responses of receivers or receivers of duplex transceivers

The provisions of EN 301 489-1 [1], subclause 4.4 shall apply with the following modification.

Responses on receivers or duplex transceivers occurring during the test at discrete frequencies which are narrow band responses (spurious responses), are identified by the following method:

- if during an immunity test the speech output signal level being monitored goes outside the specified figure, it is necessary to establish whether the speech output signal level increase is due to a narrow band response or to a wide band phenomenon. Therefore, the test shall be repeated with the unwanted signal frequency increased, and then decreased by 50 kHz;
- if the speech output signal level increase disappears in either or both of the above 50 kHz offset cases, then the response is considered as a narrow band response;
- if the speech output signal level increase does not disappear, this may be due to the fact that the offset has made the frequency of the unwanted signal correspond to the frequency of another narrow band response. Under these circumstances the procedure is repeated with the increase and decrease of the frequency of the unwanted signal set to 62,5 kHz;
- if the speech output signal level increase still does not disappear with the increased and/or decreased frequency, the phenomena is considered wide band and therefore an EMC problem and the equipment fails the test.

Narrow band responses are disregarded.

4.5 Normal test modulation

The wanted RF input signal for receivers or the receiver part of transceivers is the appropriate RF carrier signal meeting the requirements of the relevant functional standards, that does not carry any customer related modulation, e.g. audio, speech or data.

The audio, speech and/or data input port of transmitters or the transmitter part of transceivers is not provided with any customer related modulation during the EMC tests. The speech input port of mobile and portable radio equipment shall be sealed adequately during the EMC tests (see figure 2).

The reference test peak deviation shall be two-thirds of system maximum peak deviation, or as specified in the appropriate product documentation for performance assessment during degradation measurements. The frequency deviation of any supervisory modulation present is ignored. Examples of supervisory modulation are the SAT tone used in ETACS and phi tone used in NMT.

EXAMPLE: The reference frequency test deviation for ETACS is $\pm 6,4$ kHz ($\pm 9,5$ kHz maximum audio frequency deviation) and $\pm 3,0$ kHz for NMT ($\pm 4,7$ kHz maximum audio frequency deviation).

5 Performance assessment

5.1 General

The provisions of EN 301 489-1 [1], subclause 5.1 apply with the following modification.

The volume setting used shall be recorded in the test report.

5.2 Equipment which can provide a communication link

The provisions of EN 301 489-1 [1], subclause 5.1 shall apply with the following modification.

The test arrangement and signals, given in clause 4, apply to radio equipment or a combination of a radio equipment and ancillary equipment which permits the establishment of a communication link.

5.3 Equipment which does not provide a communication link

The provisions of EN 301 489-1 [1], subclause 5.3 shall apply.

5.4 Ancillary equipment

The provisions of EN 301 489-1 [1], subclause 5.4 shall apply.

5.5 Equipment classification

The provisions of EN 301 489-1 [1], subclause 5.5 shall apply.

6 Performance criteria

The provisions of EN 301 489-1 [1], clause 6 shall apply. In addition the performance criteria set out in this present document, clause 6 and its subclauses 6.1, 6.2, 6.3, and 6.4 shall apply as appropriate.

The establishment and maintenance of a communications link and in the case of mobiles and portables the assessment of audio breakthrough by monitoring speech output signal level, are used as the performance criteria to ensure that all the primary functions of the transmitter and receiver are evaluated during the immunity tests.

The maintenance of a communications link shall be assessed by using an indicator which may be part of the test system or the equipment under test.

If an equipment is of a specialized nature, such that the performance criteria described in the following subclauses are not appropriate, then the manufacturer shall declare, for inclusion in the test report, his own specification for an acceptable level of performance or degradation of performance during and/or after testing, as required by this present document. The performance specification shall be included in the product description and documentation. The performance criteria specified by the manufacturer shall, however, give the same degree of immunity protection as called for in the following subclauses.

6.1 Performance criteria for Continuous phenomena applied to Transmitters (CT)

A communication link shall be established at the start of the test, and maintained during the test, (see subclauses 4.2.1).

For mobiles and portables, the uplink and downlink speech output levels shall be at least 35 dB less than the previously recorded reference levels in the case of EUT's using audio 2:1 companding, or 18 dB less in the case of EUT's without companding. The measurement shall be performed via an audio Band Pass Filter (BPF) of width 200 Hz, centred on 1 kHz.

At the conclusion of the test the EUT shall operate as intended with no loss of user control functions or stored data, and the communication link shall have been maintained. Where the EUT is a mobile or portable, in addition to confirming this performance during a call, the test shall also be performed in idle mode, and the transmitter shall not unintentionally operate. The EUT's transmitter unintentionally operates when the EUT emits transmit energy unintentionally at a level greater than -50 dB with respect to the EUT's maximum transmit level for greater than 100 ms. The particular system's nominal transmit frequency $\pm 20\%$ shall be the frequency range inside of which false transmission shall be monitored.

Where the EUT is a transmitter only, tests shall be performed with the EUT in standby mode to ensure that unintentional transmission does not occur. The EUT's transmitter unintentionally transmits when the EUT emits transmit energy unintentionally at a level greater than -50 dB with respect to the EUT's maximum transmit level for greater than 100 ms. The particular system's nominal transmit frequency $\pm 20\%$ shall be the frequency range inside of which false transmission shall be monitored.

6.2 Performance criteria for Transient phenomena applied to Transmitters (TT)

A communications link shall be established at the start of the test, (see subclause 4.2.1).

At the conclusion of each exposure the EUT shall operate with no user noticeable loss of the communication link.

At the conclusion of the total test comprising the series of individual exposures the EUT shall operate as intended with no loss of user control functions or stored data, as declared by the manufacturer, and the communication link shall have been maintained.

In addition to confirming this performance during a call, the test shall also be performed in idle mode, and the transmitter shall not unintentionally operate. The EUT's transmitter unintentionally operates when the EUT emits transmit energy unintentionally at a level greater than -50 dB with respect to the EUT's maximum transmit level for greater than 100 ms. The particular system's nominal transmit frequency $\pm 20\%$ shall be the frequency range inside of which false transmission shall be monitored.

Where the EUT is a transmitter only, tests shall be performed with the EUT in standby mode to ensure that unintentional transmission does not occur. The EUT's transmitter unintentionally transmits when the EUT emits transmit energy unintentionally at a level greater than -50 dB with respect to the EUT's maximum transmit level for greater than 100 ms. The particular system's nominal transmit frequency $\pm 20\%$ shall be the frequency range inside of which false transmission shall be monitored.

6.3 Performance criteria for Continuous phenomena applied to Receivers (CR)

A communications link shall be established at the start of the test, and maintained during the test, (see subclause 4.2.1).

For mobiles and portables, the uplink and downlink speech output levels shall be at least 35 dB less than the previously recorded reference in the case of EUT's using audio 2:1 companding, or 18 dB less in the case of EUT's without companding. The measurement shall be performed via an audio band pass filter of width 200 Hz, centred on 1 kHz.

At the conclusion of the test the EUT shall operate as intended with no loss of user control functions or stored data, and the communication link shall have been maintained.

6.4 Performance criteria for Transient phenomena applied to Receivers (TR)

A communications link shall be established at the start of the test, (see subclauses 4.2.1).

At the conclusion of each exposure the EUT shall operate with no user noticeable loss of the communication link.

At the conclusion of the total test comprising the series of individual exposures, the EUT shall operate as intended with no loss of user control functions or stored data, as declared by the manufacturer, and the communication link shall have been maintained.

7 Applicability overview tables

7.1 Emission

7.1.1 General

EN 301 489-1 [1], table 2, contains the applicability of EMC emission measurements to the relevant ports of radio and/or associated ancillary equipment

7.1.2 Special conditions

No special conditions shall apply to the analogue cellular radio equipment covered by the scope of the present document.

7.2 Immunity

7.2.1 General

EN 301 489-1 [1], table 3, contains the applicability of EMC immunity measurements to the relevant ports of the radio and/or associated ancillary equipment.

7.2.2 Special conditions

No special conditions shall apply to the analogue cellular radio equipment covered by the scope of the present document.

Annex A (informative): Examples of analogue cellular radio communications equipment in the scope of the present document

The present document covers types of analogue cellular radio communications equipment as set out below.

A.1 Mobile Radio Telephone equipment used in Net-C

The present document applies to Mobile Radio Telephone equipment used in Net-C, and associated ancillary equipment.

Mobile Radio Telephone equipment used in Net-C covered by the scope of the present document is defined in the following standard:

- [4] BAPT 211 ZV 08 (January 1995): "Zulassungsvorschrift für Funktelefongeräte im Netz C" (Type Approval Specification for Mobile Radio Telephone equipment used in Net-C).

A.2 Mobile Radio Telephone equipment used in the Nordic Mobile Telephone (NMT 450 and NMT 900) service

The present document applies to Mobile Radio Telephone equipment used in the Nordic Mobile Telephone (NMT) service, and associated ancillary equipment.

Mobile Radio Telephone equipment used in the Nordic Mobile Telephone (NMT) service covered by the scope of the present document are defined in the following standards:

- [5] NMT DOC 450-3 (1995): "Automatic Cellular Mobile Telephone System, Technical Specification for the Mobile Station".
- [6] NMT Doc 900-3 (1995): "Automatic Cellular Mobile Telephone System, Technical Specification for the Mobile Station".

A.3 Mobile Radio Telephone equipment used in the Radiocom 2000 service (R 2000)

The present document applies to Mobile Radio Telephone equipment used in the Radiocom 2000 service (R 2000 [7]), and associated ancillary equipment.

Mobile Radio Telephone equipment used in the Radiocom 2000 service (R 2000 [7]) covered by the scope of the present document is defined in the following standard:

- [7] R 2000 (1991): "Specification des stations mobiles radiocom 2000", Version 3 (Specification for Mobile Stations of Radiocom 2000).

A.4 Mobile Radio Telephone equipment used in the Extended Total Access Communications System (ETACS) and in the Total Access Communications System (TACS)

The present document applies to Mobile Radio Telephone equipment used in the ETACS and TACS systems, and associated ancillary equipment.

Mobile Radio Telephone equipment used in the ETACS and TACS systems covered by the scope of the present document are defined in the following standards:

- [8] PD 7005 (1996): "Essential requirements for terminal equipment intended for connection for connection to the extended total access communications system (ETACS)".
- [10] BS 6940-1 (1990): "Total Access Communication System (TACS). Specification for performance requirements for mobile stations".

History

Document history			
V1.1.1	May 2000	One-step Approval Procedure	OAP 20000922: 2000-05-24 to 2000-09-22