



**ElectroMagnetic Compatibility (EMC)
standard for radio equipment and services;
Part 12: Specific conditions for Very Small Aperture
Terminal, Satellite Interactive Earth Stations operated
in the frequency ranges between 4 GHz and 30 GHz
in the Fixed Satellite Service (FSS);
Harmonised Standard for ElectroMagnetic Compatibility**

Reference

REN/ERM-EMC-404

Keywordsearth station, EMC, FSS, harmonised standard,
radio, regulation, satellite, SNG, testing, VSAT**ETSI**

650 Route des Lucioles
F-06921 Sophia Antipolis Cedex - FRANCE

Tel.: +33 4 92 94 42 00 Fax: +33 4 93 65 47 16

Siret N° 348 623 562 00017 - NAF 742 C
Association à but non lucratif enregistrée à la
Sous-Préfecture de Grasse (06) N° 7803/88

Important notice

The present document can be downloaded from:

<http://www.etsi.org/standards-search>

The present document may be made available in electronic versions and/or in print. The content of any electronic and/or print versions of the present document shall not be modified without the prior written authorization of ETSI. In case of any existing or perceived difference in contents between such versions and/or in print, the prevailing version of an ETSI deliverable is the one made publicly available in PDF format at www.etsi.org/deliver.

Users of the present document should be aware that the document may be subject to revision or change of status.

Information on the current status of this and other ETSI documents is available at

<https://portal.etsi.org/TB/ETSIDeliverableStatus.aspx>

If you find errors in the present document, please send your comment to one of the following services:

<https://portal.etsi.org/People/CommitteeSupportStaff.aspx>

Copyright Notification

No part may be reproduced or utilized in any form or by any means, electronic or mechanical, including photocopying and microfilm except as authorized by written permission of ETSI.

The content of the PDF version shall not be modified without the written authorization of ETSI.

The copyright and the foregoing restriction extend to reproduction in all media.

© ETSI 2021.

All rights reserved.

DECT™, **PLUGTESTS™**, **UMTS™** and the ETSI logo are trademarks of ETSI registered for the benefit of its Members.

3GPP™ and **LTE™** are trademarks of ETSI registered for the benefit of its Members and of the 3GPP Organizational Partners.

oneM2M™ logo is a trademark of ETSI registered for the benefit of its Members and of the oneM2M Partners.

GSM® and the GSM logo are trademarks registered and owned by the GSM Association.

Contents

Intellectual Property Rights	5
Foreword.....	5
Modal verbs terminology.....	5
1 Scope	6
2 References	6
2.1 Normative references	6
2.2 Informative references.....	7
3 Definition of terms, symbols and abbreviations.....	8
3.1 Terms.....	8
3.2 Symbols.....	8
3.3 Abbreviations	8
4 Test conditions	9
4.1 General	9
4.2 Arrangements for test signals	9
4.2.0 General.....	9
4.2.1 Arrangements for test signals at the input of transmitters.....	10
4.2.2 Arrangements for test signals at the output of transmitters.....	10
4.2.3 Arrangements for test signals at the input of receivers	10
4.2.4 Arrangements for test signals at the output of receivers	10
4.3 Exclusion bands.....	10
4.3.1 Exclusion band for transmitters or the transmitter part of transceivers.....	10
4.3.2 Exclusion band for receivers or the receiver part of transceivers	10
5 Performance assessment.....	10
5.1 General	10
5.2 Equipment configuration(s).....	11
5.3 Equipment classification	11
6 Performance criteria	12
6.0 General	12
6.1 Performance criteria for Continuous phenomena applied to the EUT.....	12
6.2 Performance criteria for Transient phenomena applied to a class A EUT.....	12
6.3 Performance criteria for Transient phenomena applied to a class B EUT.....	12
7 Requirements.....	12
7.1 Emission.....	12
7.1.1 General.....	12
7.1.2 Special conditions	13
7.2 Immunity	13
7.2.1 General.....	13
7.2.2 Special conditions.....	14
Annex A (informative): Relationship between the present document and the essential requirements of Directive 2014/53/EU	16
Annex B (informative): Definitions of Satellite Earth Stations (ES) within the scope of the present document.....	18
B.0 General	18
B.1 Transmit only and Transmit and receive Ku band VSATs	18
B.2 Receive-only Ku band VSATs.....	18
B.3 Transmit only and Transmit and receive C band VSATs.....	19
B.4 Receive-only C band VSATs	19

B.5	Satellite News Gathering (SNG) Ku band Transportable Earth Stations (TESs).....	20
B.6	Satellite Interactive Terminals (SITs)	20
B.7	Satellite User Terminals (SUTs) transmitting in the frequency range 29,5 GHz to 30,0 GHz	21
B.8	Satellite User Terminals (SUTs) transmitting in the frequency range 27,5 GHz to 29,5 GHz	22
B.9	Satellite Earth Station on Trains (EST) transmitting in the frequency range 14,0 GHz to 14,5 GHz....	22
B.10	Earth Stations On Mobile Platforms (ESOMP) transmitting in the frequency range 27,5 GHz to 30,0 GHz	23
Annex C (informative):	Bibliography	25
Annex D (informative):	Change history	26
History		27

Intellectual Property Rights

Essential patents

IPRs essential or potentially essential to normative deliverables may have been declared to ETSI. The information pertaining to these essential IPRs, if any, is publicly available for **ETSI members and non-members**, and can be found in ETSI SR 000 314: "*Intellectual Property Rights (IPRs); Essential, or potentially Essential, IPRs notified to ETSI in respect of ETSI standards*", which is available from the ETSI Secretariat. Latest updates are available on the ETSI Web server (<https://ipr.etsi.org/>).

Pursuant to the ETSI IPR Policy, no investigation, including IPR searches, has been carried out by ETSI. No guarantee can be given as to the existence of other IPRs not referenced in ETSI SR 000 314 (or the updates on the ETSI Web server) which are, or may be, or may become, essential to the present document.

Trademarks

The present document may include trademarks and/or tradenames which are asserted and/or registered by their owners. ETSI claims no ownership of these except for any which are indicated as being the property of ETSI, and conveys no right to use or reproduce any trademark and/or tradename. Mention of those trademarks in the present document does not constitute an endorsement by ETSI of products, services or organizations associated with those trademarks.

Foreword

This draft Harmonised European Standard (EN) has been produced by ETSI Technical Committee Electromagnetic compatibility and Radio spectrum Matters (ERM), and is now submitted for the combined Public Enquiry and Vote phase of the ETSI standards EN Approval Procedure.

The present document has been prepared under the Commission's standardisation request C(2015) 5376 final [i.6] to provide one voluntary means of conforming to the essential requirements of Directive 2014/53/EU on the harmonisation of the laws of the Member States relating to the making available on the market of radio equipment and repealing Directive 1999/5/EC [i.5].

Once the present document is cited in the Official Journal of the European Union under that Directive, compliance with the normative clauses of the present document given in table A.1 confers, within the limits of the scope of the present document, a presumption of conformity with the corresponding essential requirements of that Directive and associated EFTA regulations.

The present document is part 12 of a multi-part deliverable. Full details of the entire series can be found in part 1 [1].

Proposed national transposition dates	
Date of latest announcement of this EN (doa):	3 months after ETSI publication
Date of latest publication of new National Standard or endorsement of this EN (dop/e):	6 months after doa
Date of withdrawal of any conflicting National Standard (dow):	18 months after doa

Modal verbs terminology

In the present document "**shall**", "**shall not**", "**should**", "**should not**", "**may**", "**need not**", "**will**", "**will not**", "**can**" and "**cannot**" are to be interpreted as described in clause 3.2 of the [ETSI Drafting Rules](#) (Verbal forms for the expression of provisions).

"**must**" and "**must not**" are **NOT** allowed in ETSI deliverables except when used in direct citation.

1 Scope

The present document specifies technical characteristics and methods of measurement for the Earth Stations (ESs) operating in the frequency ranges between 3,625 GHz and 30 GHz in the Fixed Satellite Service (FSS) bands, and associated ancillary equipment in respect of ElectroMagnetic Compatibility (EMC).

Technical specifications related to the antenna port and emissions from the enclosure port of the Earth Stations (ESs) are not included in the present document. Such technical specifications are found in the relevant product standards for the effective use of the radio spectrum, see table 1.

Table 1: Radio Technologies in scope of the present document

Technology	ETSI Standard
VSAT for Transmit-only, transmit/receive or receive-only satellite Earth Stations operating in the 10,70 GHz to 14,50 GHz frequency bands	ETSI EN 301 428 [i.7]
ES for Satellite News Gathering Transportable Earth Stations (SNG TESS) operating in the 10,70 GHz to 14,50 GHz frequency bands	ETSI EN 301 430 [i.8]
VSAT for Transmit-only, transmit-and-receive, receive-only satellite Earth Stations operating in the 3,625 GHz to 6,425 GHz frequency bands	ETSI EN 301 443 [i.9]
ES for Satellite Interactive Terminals (SIT) and Satellite User Terminals (SUT) transmitting towards satellites in geostationary orbit in the 19,70 GHz to 30,0 GHz frequency bands	ETSI EN 301 459 [i.10]
ES for Satellite User Terminals (SUT) transmitting towards satellites in geostationary orbit in the 17,70 GHz to 29,5 GHz frequency bands	ETSI EN 301 360 [i.11]
ES for Earth Stations On Mobile Platforms (ESOMP) transmitting towards satellites in geostationary orbit, operating in the 17,70 GHz to 30,0 GHz frequency bands	ETSI EN 303 978 [i.12]

Definitions of the type of Earth Stations (ESs) operating in the frequency ranges between 3,625 GHz and 30 GHz in the Fixed Satellite Service (FSS) covered by the present document are given in annex B. The environmental classification used in the present document are as stated in ETSI EN 301 489-1 [1].

NOTE: The relationship between the present document and essential requirements of article 3.1(b) of Directive 2014/53/EU [i.5] is given in annex A.

2 References

2.1 Normative references

References are either specific (identified by date of publication and/or edition number or version number) or non-specific. For specific references, only the cited version applies. For non-specific references, the latest version of the referenced document (including any amendments) applies.

Referenced documents which are not found to be publicly available in the expected location might be found at <https://docbox.etsi.org/Reference/>.

NOTE: While any hyperlinks included in this clause were valid at the time of publication, ETSI cannot guarantee their long term validity.

The following referenced documents are necessary for the application of the present document.

- [1] ETSI EN 301 489-1 (V2.2.3) (11-2019): "ElectroMagnetic Compatibility (EMC) standard for radio equipment and services; Part 1: Common technical requirements; Harmonised Standard for ElectroMagnetic Compatibility".
- [2] EN 61000-3-3 (2013) + A1 (2019): "Electromagnetic compatibility (EMC) - Part 3-3: Limits - Limitation of voltage changes, voltage fluctuations and flicker in public low-voltage supply systems, for equipment with rated current ≤ 16 A per phase and not subject to conditional connection", (produced by CENELEC).

2.2 Informative references

References are either specific (identified by date of publication and/or edition number or version number) or non-specific. For specific references, only the cited version applies. For non-specific references, the latest version of the referenced document (including any amendments) applies.

NOTE: While any hyperlinks included in this clause were valid at the time of publication, ETSI cannot guarantee their long term validity.

The following referenced documents are not necessary for the application of the present document but they assist the user with regard to a particular subject area.

- [i.1] Void.
- [i.2] Void.
- [i.3] ERC/DEC(00)08: "ERC Decision of 19 October 2000 on the use of the band 10.7 - 12.5 GHz by the fixed service and Earth stations of the broadcasting-satellite and fixed-satellite Service (space-to-Earth)".
- [i.4] Void.
- [i.5] Directive 2014/53/EU of the European Parliament and of the Council of 16 April 2014 on the harmonisation of the laws of the Member States relating to the making available on the market of radio equipment and repealing Directive 1999/5/EC.
- [i.6] Commission Implementing Decision C(2015) 5376 final of 4.8.2015 on a standardisation request to the European Committee for Electrotechnical Standardisation and to the European Telecommunications Standards Institute as regards radio equipment in support of Directive 2014/53/EU of the European Parliament and of the Council.
- [i.7] ETSI EN 301 428: "Satellite Earth Stations and Systems (SES); Harmonized Standard for Very Small Aperture Terminal (VSAT); Transmit-only, transmit/receive or receive-only satellite earth stations operating in the 11/12/14 GHz frequency bands covering the essential requirements of article 3.2 of the Directive 2014/53/EU".
- [i.8] ETSI EN 301 430: "Satellite Earth Stations and Systems (SES); Harmonised Standard for Satellite News Gathering Transportable Earth Stations (SNG TES) operating in the 11 GHz to 12 GHz/13 GHz to 14 GHz frequency bands covering the essential requirements of article 3.2 of the Directive 2014/53/EU".
- [i.9] ETSI EN 301 443: "Satellite Earth Stations and Systems (SES); Harmonised Standard for Very Small Aperture Terminal (VSAT); Transmit-only, transmit-and-receive, receive-only satellite earth stations operating in the 4 GHz and 6 GHz frequency bands covering the essential requirements of article 3.2 of the Directive 2014/53/EU".
- [i.10] ETSI EN 301 459: "Satellite Earth Stations and Systems (SES); Harmonised Standard for Satellite Interactive Terminals (SIT) and Satellite User Terminals (SUT) transmitting towards satellites in geostationary orbit, operating in the 29,5 GHz to 30,0 GHz frequency bands covering the essential requirements of article 3.2 of the Directive 2014/53/EU".
- [i.11] ETSI EN 301 360: "Satellite Earth Stations and Systems (SES); Harmonised Standard for Satellite Interactive Terminals (SIT) and Satellite User Terminals (SUT) transmitting towards satellites in geostationary orbit, operating in the 27,5 GHz to 29,5 GHz frequency bands covering the essential requirements of article 3.2 of the Directive 2014/53/EU".
- [i.12] ETSI EN 303 978: "Satellite Earth Stations and Systems (SES); Harmonised Standard for Earth Stations on Mobile Platforms (ESOMP) transmitting towards satellites in geostationary orbit, operating in the 27,5 GHz to 30,0 GHz frequency bands covering the essential requirements of article 3.2 of the Directive 2014/53/EU".
- [i.13] ITU Radio Regulations (2020).

3 Definition of terms, symbols and abbreviations

3.1 Terms

For the purposes of the present document, the terms given in ETSI EN 301 489-1 [1] and the following apply:

ancillary equipment: electrical or electronic equipment, that is intended to be used with a receiver or transmitter

NOTE 1: It is considered as an ancillary equipment if:

- the equipment is intended for use with a receiver or transmitter to provide additional operational and/or control features to the radio equipment (e.g. to extend control to another position or location);
- the ancillary equipment cannot be used without being connected to radio equipment to provide user functions independently of a receiver or transmitter; and
- the receiver or transmitter, to which it is connected, is capable of providing some intended operation such as transmitting and/or receiving without the ancillary equipment (i.e. it is not a sub-unit of the main equipment essential to the main equipment basic functions).

NOTE 2: An example of ancillary equipment would be a docking station for radio equipment whose interface is dedicated to a particular product or range of products.

carrier-off state: state in which the ES is authorized to transmit, and when it does not transmit any signal, either authorized by a Centralized Control and Monitoring Functions (CCMF) or a Network Control Facility (NCF) when designed for unattended operation or by local control when designed for attended operation

NOTE: The existence of a carrier-off state depends on the system of transmission used. For ES designed for continuous transmission mode there may be no carrier-off state.

carrier-on state: state in which the ES is authorized to transmit, and when it transmits a signal, either authorized by a CCMF or a NCF when designed for unattended operation or by local control when designed for attended operation

critical stored data: data that is essential for an EUT to perform a primary function in accordance with that EUT's specification

NOTE: This may include data previously stored by the user.

drive equipment: equipment used to enable the EUT to operate as intended during the test process

terrestrial port: a port for interconnecting earth-based equipments

transmission disabled state: state in which the ES is not authorized to transmit either by a CCMF or a NCF respectively when designed for unattended operation or by local control when designed for attended operation

3.2 Symbols

For the purposes of the present document, the following symbols apply:

P_{\min} minimum power required to establish a communication link

3.3 Abbreviations

For the purposes of the present document, the following abbreviations apply:

AC	Alternating Current
AMSS	Aeronautical Mobile Satellite Service
BSS	Broadcast Satellite Service
CCMF	Centralized Control and Monitoring Functions
CEPT	European Conference of Postal and Telecommunications administrations

DC	Direct Current
EFTA	European Free Trade Association
EIRP	Equivalent Isotropically Radiated Power
EMC	ElectroMagnetic Compatibility
EME	Externally Mounted Equipment
ES	Earth Station
ESOMP	Earth Stations On Mobile Platforms
EST	Earth Station on Trains
EUT	Equipment Under Test
FS	Fixed Services
FSS	Fixed Satellite Service
IME	Internally Mounted Equipment
kV	kilo Volt
LMSS	Land Mobile Satellite Service
LNB	Low Noise Block converter
MMSS	Marine Mobile Satellite Service
MSS	Mobile Satellite Service
NCF	Network Control Facility
QTMA	Quality of Transmission Measurement Apparatus
RF	Radio Frequency
SIT	Satellite Interactive Terminals
SNG	Satellite News Gathering
SUT	Satellite User Terminals
TES	Transportable Earth Station
VSAT	Very Small Aperture Terminal

4 Test conditions

4.1 General

For the purposes of the present document, the test conditions of ETSI EN 301 489-1 [1], clause 4 shall apply with the following additions. Further product type related test conditions for Earth Stations are specified in the present document.

For Earth Stations with or without ancillary equipment, and/or various terrestrial ports, the selection of test configurations shall be determined. The assessment shall include sufficient representative configurations of the ES to adequately exercise the equipment. These configurations shall be recorded in the test report.

In clauses 4.2 and 4.3, the Equipment Under Test (EUT) is an ES with the selected configuration of ancillary equipment.

4.2 Arrangements for test signals

4.2.0 General

The provisions of ETSI EN 301 489-1 [1], clause 4.2.0 shall apply with the following additions.

In order to measure the system emissions and electromagnetic immunity under operational conditions, the following arrangements shall be provided:

- a) a drive equipment to put the ES terminal in its normal operating mode, and providing the ES with a receive signal to emulate the operational conditions of reception. This equipment shall control the EUT, when it is capable of transmission, so that it switches between the transmission disabled, carrier-on and carrier-off states;
- b) a Quality of Transmission Measurement Apparatus (QTMA).

For the measurement of the quality of transmission, a communications link shall be established and the wanted input signal shall be applied to the Radio Frequency (RF) input of the receiver via the antenna.

The QTMA and the source of the wanted input signal shall be located outside the test environment.

4.2.1 Arrangements for test signals at the input of transmitters

The provisions of ETSI EN 301 489-1 [1], clause 4.2.1 shall apply.

4.2.2 Arrangements for test signals at the output of transmitters

The provisions of ETSI EN 301 489-1 [1], clause 4.2.2 shall apply.

4.2.3 Arrangements for test signals at the input of receivers

The provisions of ETSI EN 301 489-1 [1], clause 4.2.3 shall apply with the following addition.

For radiated immunity, the level of the wanted signal at the input of the receiver or the enclosure port of the EUT, shall be 20 dB (± 3 dB) above the P_{\min} for the EUT. For all other tests the level of the wanted signal, required to establish a communication link, shall be representative of the EUT intended use.

NOTE: A simple method to establish the required communication link is establish link, reduce power to point of link failure then increase by 20 dB.

4.2.4 Arrangements for test signals at the output of receivers

The provisions of ETSI EN 301 489-1 [1], clause 4.2.4 shall apply.

4.3 Exclusion bands

4.3.1 Exclusion band for transmitters or the transmitter part of transceivers

The provisions of ETSI EN 301 489-1 [1], clause 4.3.2 shall apply.

4.3.2 Exclusion band for receivers or the receiver part of transceivers

For EUT that operate above 6 GHz, there is no exclusion band specified as test ranges stop at 6 GHz.

For EUT that operate below 6 GHz, the provisions of ETSI EN 301 489-1 [1], clause 4.3.3 shall apply.

5 Performance assessment

5.1 General

The provision of ETSI EN 301 489-1 [1], annex C should apply. In addition, the following information should be recorded in the test report:

- the dedicated class (A or B) for the ES in accordance with the information contained in the instructions accompanying the ES (see clause 5.3);
- the ranges of the operational parameters, e.g. the power delivered to the antenna, the frequency ranges;
- the minimum quality of transmission, and the method to be used to assess it.

This information shall be in accordance with the documentation accompanying the equipment.

5.2 Equipment configuration(s)

For radiation measurements in carrier-on state, the ES shall be put in a continuous transmit mode or to the maximum burst rate where applicable. The ES shall be operated at the maximum operating Equivalent Isotropically Radiated Power (EIRP).

Test configuration is shown in figure 1.

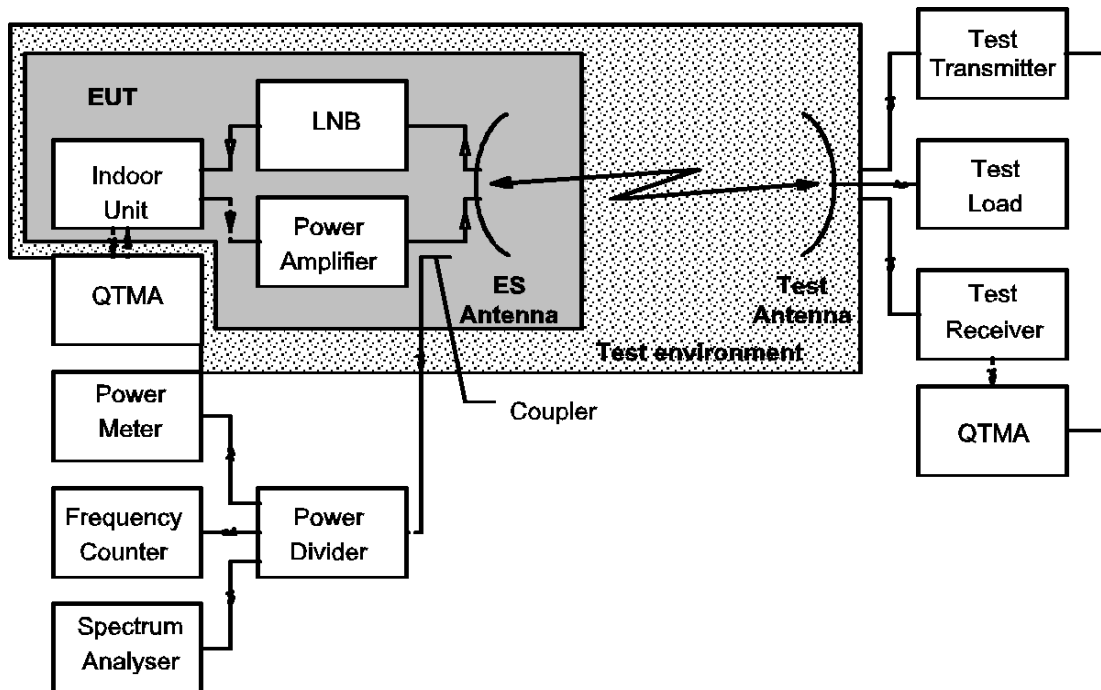

Figure 1: Test configuration

For the tests, the ES antenna reflector and the test antenna may be removed at their flanges and be replaced by one direct wave guide connection.

The following test equipment shall be the means whereby the correct operation of the EUT is verified:

- the power meter measures the output power and is used to confirm the transmission disabled, carrier-on and carrier-off states and output level consistency;
- the frequency counter measures the centre frequency of the radiated carrier in the absence of modulation;
- the spectrum analyser measures the bandwidth of the transmission;
- the test receiver is used to demodulate the transmitted signal;
- the two QTMA are used in conjunction with each other to assess the quality of transmission;
- the test transmitter is used to control the switching between transmission disabled, carrier-on and carrier-off states by transmitting the control and monitoring signals.

5.3 Equipment classification

The equipment are classified into the two classes:

- class A of ES is where no loss of function is accepted during immunity testing with EMC transient phenomena as defined in clause 6.2;
- class B ES is where any loss of function during immunity testing with EMC transient phenomena shall be in accordance with performance criteria defined in clause 6.3.

6 Performance criteria

6.0 General

Only the performance criteria specified in the present document or in ETSI EN 301 489-1 [1] where referenced shall apply.

The definition of the functions of the EUT, including its ancillary equipment, to be checked during and after the EMC tests shall operate as intended.

The equipment shall meet the minimum performance criteria as specified in clauses 6.1, 6.2 and 6.3.

6.1 Performance criteria for Continuous phenomena applied to the EUT

The EUT shall be considered to satisfy the immunity requirements if the provisions of ETSI EN 301 489-1 [1], clause 6.1 are met.

6.2 Performance criteria for Transient phenomena applied to a class A EUT

The EUT shall be considered to satisfy the immunity requirement if there is no loss of function during testing with EMC transient phenomena.

The communication link shall be maintained during the test.

6.3 Performance criteria for Transient phenomena applied to a class B EUT

The EUT shall be considered to satisfy the immunity requirements if after the EMC transient phenomena tests, any loss of function shall be self-recoverable and the equipment shall operate as intended with no loss of critical stored data.

The communication link shall be maintained during the test.

7 Requirements

7.1 Emission

7.1.1 General

Table 2 contains the applicability of EMC emission requirements to the relevant terrestrial ports of radio and/or associated ancillary equipment.

Table 2: Emission requirements

Phenomenon	Terrestrial Port	Applicability			Reference clause
		Fixed equipment	Vehicular equipment	Portable equipment	
radiated emission	enclosure port of ancillary equipment	applicable	applicable	applicable	7.1.2
conducted emission	DC power input/output port	applicable	applicable	not applicable	7.1.2
conducted emission	AC mains input/output port	applicable	not applicable	not applicable	ETSI EN 301 489-1 [1], clause 8.4
harmonic current emissions	AC mains input port	applicable	not applicable	not applicable	ETSI EN 301 489-1 [1], clause 8.5
voltage fluctuations and flicker	AC mains input port	applicable	not applicable	not applicable	7.1.2
conducted emission	wired network port	applicable	not applicable	not applicable	ETSI EN 301 489-1 [1], clause 8.7

7.1.2 Special conditions

The following special conditions set out in table 3, relate to the emission test methods used in ETSI EN 301 489-1 [1], clause 8.

Table 3: Special conditions for EMC emission measurements

Reference to clauses in ETSI EN 301 489-1 [1]	Special product-related conditions, additional to or modifying the test conditions in ETSI EN 301 489-1 [1], clause 8
8.2.3 Limits; Enclosure of ancillary equipment measured on a stand alone basis	The requirements for radiated emission from the enclosure port is applicable to the complete system. The transmit carrier frequency and the receive carrier frequency shall be selected so that they give the maximum spurious radiation.
8.3 DC power input/output ports	The requirements of ETSI EN 301 489-1 [1], clause 8.3 shall be applied where the cable length exceeds 3 m or when connected to a vehicle power supply.
8.6 Voltage fluctuations and flicker	The requirements of ETSI EN 301 489-1 [1], clause 8.6 shall be applied with the exception of the first paragraph of clause 6.1 of EN 61000-3-3 [2].

7.2 Immunity

7.2.1 General

Table 4 contains the applicability of EMC immunity requirements to the relevant terrestrial ports of radio and/or associated ancillary equipment.

Table 4: Immunity requirements

Phenomenon	Terrestrial Port	Applicability			Reference clause	Performance criteria clause
		Fixed equipment	Vehicular equipment	Portable equipment		
RF electromagnetic field (80 MHz to 6 000 MHz)	enclosure	applicable	applicable	applicable	ETSI EN 301 489-1 [1], clause 9.2 and clause 7.2.2 of present document	6.1

Phenomenon	Terrestrial Port	Applicability			Reference clause	Performance criteria clause
		Fixed equipment	Vehicular equipment	Portable equipment		
electrostatic discharge	enclosure	applicable	applicable	applicable	ETSI EN 301 489-1 [1], clause 9.3 and clause 7.2.2 of present document	6.2, 6.3
fast transients common mode	signal, wired network and control	applicable	not applicable	not applicable	ETSI EN 301 489-1 [1], clause 9.4 and clause 7.2.2 of present document	6.2, 6.3
	DC power	applicable	not applicable	not applicable		
	AC mains power	applicable	not applicable	not applicable		
RF common mode 0,15 MHz to 80 MHz	signal, wired network and control	applicable	not applicable	not applicable	ETSI EN 301 489-1 [1], clause 9.5	6.1
	DC power	applicable	applicable	not applicable		
	AC mains power	applicable	applicable	not applicable		
transients and surges	DC power input	not applicable	applicable	not applicable	ETSI EN 301 489-1 [1], clause 9.6	6.2, 6.3
voltage dips and interruptions	AC mains power input	applicable	not applicable	not applicable	ETSI EN 301 489-1 [1] clause 9.7 and clause 7.2.2 of present document	6.2, 6.3
surges, line to line and line to ground	AC mains power input ports, wired network ports	applicable	not applicable	not applicable	ETSI EN 301 489-1 [1], clause 9.8 and clause 7.2.2 of present document	6.2, 6.3
	wired network	applicable	not applicable	not applicable		

Portable equipment, or combinations of equipment, capable of being powered for intended use by the main battery of a vehicle shall additionally be considered as vehicular equipment.

Portable or vehicular equipment, or combinations of equipment, capable of being powered for intended use by AC mains shall additionally be considered as fixed equipment.

7.2.2 Special conditions

The following special conditions set out in table 5, relate to the immunity test methods and performance criteria used in ETSI EN 301 489-1 [1], clause 9.

Table 5: Special conditions for EMC immunity tests

Reference to clauses in ETSI EN 301 489-1 [1]	Special product-related conditions, additional to or modifying the test conditions in ETSI EN 301 489-1 [1], clause 9
9.2.2 Radio frequency electromagnetic field	A test level of 10 V/m, shall be applied to ESTs.
9.3.2 Electrostatic discharge	A contact discharge severity level of ± 6 kV and an air discharge severity level of ± 8 kV shall be applied to ESTs.
9.3.3 Performance criteria; Electrostatic discharge	The performance criteria (clause 6.2) shall apply to grade A ES. The performance criteria (clause 6.3) shall apply to grade B ES.
9.4.3 Performance criteria; Fast transient, common mode	The performance criteria (clause 6.2) shall apply to grade A ES. The performance criteria (clause 6.3) shall apply to grade B ES.
9.7.3 Performance criteria; Voltage dips and interruptions	a) for a voltage dip corresponding to a reduction of the supply voltage of 30 % for 10 ms, the performance criteria (clause 6.1) shall apply; b) for a voltage dip corresponding to a reduction of the supply voltage of 60 % for 100 ms, the performance criteria (clause 6.2) shall apply to grade A ES, and the performance criteria (clause 6.3) shall apply to grade B ES; c) for a voltage interruption corresponding to a reduction of the supply voltage of more than 95 % for 5 000 ms, the following performance criteria shall apply: <ul style="list-style-type: none"> • for equipment fitted with or connected to a battery back-up the performance criteria (clause 6.2) shall apply to both grade A and grade B ES.
9.8.3 Performance criteria; Surges	The performance criteria (clause 6.2) shall apply to grade A ES. The performance criteria (clause 6.3) shall apply to grade B ES.

Annex A (informative): Relationship between the present document and the essential requirements of Directive 2014/53/EU

The present document has been prepared under the Commission's standardisation request C(2015) 5376 final [i.6] to provide one voluntary means of conforming to the essential requirements of Directive 2014/53/EU on the harmonisation of the laws of the Member States relating to the making available on the market of radio equipment and repealing Directive 1999/5/EC [i.5].

Once the present document is cited in the Official Journal of the European Union under that Directive, compliance with the normative clauses of the present document given in table A.1 confers, within the limits of the scope of the present document, a presumption of conformity with the corresponding essential requirements of that Directive and associated EFTA regulations.

Table A.1: Relationship between the present document and the essential requirements of Directive 2014/53/EU

Harmonised Standard ETSI EN 301 489-12					
Requirement				Requirement Conditionality	
No	Description	Essential requirements of Directive	Clause(s) of the present document	U/C	Condition
1	Emissions: Enclosure of ancillary equipment measured on a stand alone basis	3.1(b)	7.1	U	
2	Emissions: DC power input/output ports	3.1(b)	7.1	C	Only where equipment has DC power input and/or output ports with a cable length greater than 3 m or from a vehicle power supply
3	Emissions: AC mains power input/output ports	3.1(b)	7.1	C	Only where equipment has AC mains power input and/or output ports
4	Emissions: Harmonic current emission (AC mains input port)	3.1(b)	7.1	C	Only where equipment has AC mains power input ports
5	Emissions: Voltage fluctuations and flicker (AC mains input ports)	3.1(b)	7.1	C	Only where equipment has AC mains power input ports
6	Emissions: Wired network ports	3.1(b)	7.1	C	Only where equipment has wired network ports
7	Immunity: Radio frequency electromagnetic field (80 MHz to 6 000 MHz)	3.1(b)	7.2	U	
8	Immunity: Electrostatic discharge	3.1(b)	7.2	U	
9	Immunity: Fast transients common mode	3.1(b)	7.2	C	Only where equipment has AC mains power input ports or DC power ports or wired network ports with cables longer than 3 m
10	Immunity: Radio frequency common mode	3.1(b)	7.2	C	Only where equipment has AC mains power input ports or DC power ports or wired network ports with cables longer than 3 m
11	Immunity: Transients and surges in the vehicular environment	3.1(b)	7.2	C	Only where equipment is fitted to a vehicle power supply
12	Immunity: Voltage dips and interruptions	3.1(b)	7.2	C	Only where equipment has AC mains power input ports
13	Immunity: Surges, line to line and line to ground	3.1(b)	7.2	C	Only where equipment has AC mains power input ports and/or wired network ports

Key to columns:**Requirement:**

- No** A unique identifier for one row of the table which may be used to identify a requirement.
- Description** A textual reference to the requirement.

Essential requirements of Directive

Identification of article(s) defining the requirement in the Directive.

Clause(s) of the present document

Identification of clause(s) defining the requirement in the present document unless another document is referenced explicitly.

Requirement Conditionality:

- U/C** Indicates whether the requirement is unconditionally applicable (U) or is conditional upon the manufacturer's claimed functionality of the equipment (C).
- Condition** Explains the conditions when the requirement is or is not applicable for a requirement which is classified "conditional".

Presumption of conformity stays valid only as long as a reference to the present document is maintained in the list published in the Official Journal of the European Union. Users of the present document should consult frequently the latest list published in the Official Journal of the European Union.

Other Union legislation may be applicable to the product(s) falling within the scope of the present document.

Annex B (informative): Definitions of Satellite Earth Stations (ESs) within the scope of the present document

B.0 General

The present document covers types of ES radio equipment as set out in the following clauses.

The CEPT has adopted the ERC Decision (00)08 [i.3] on the use of the band 10,7 GHz to 12,5 GHz by the fixed service and Earth stations of the broadcasting-satellite and fixed-satellite service (space-to-Earth).

B.1 Transmit only and Transmit and receive Ku band VSATs

The present document applies to transmit only and also to transmit and receive Very Small Aperture Terminals (VSATs) operating as part of a satellite network (e.g. star, meshed or point to point) used for the distribution and/or exchange of information between users.

In such a network a Centralized Control and Monitoring Functions (CCMF) is responsible for the monitoring and control of VSATs.

These VSATs have the following characteristics:

- operating in the exclusive part of the Ku-band allocated to the Fixed Satellite Services (FSSs), 14,00 GHz to 14,25 GHz (Earth-Space), 12,50 GHz to 12,75 GHz (Space-Earth), and/or in the shared parts of the Ku-band, allocated to the FSS and Fixed Services (FS), 14,25 GHz to 14,50 GHz (Earth-Space) and/or 10,70 GHz to 11,70 GHz (Space-Earth);
- in these frequency bands linear polarization is normally used and the system operates through satellites at 3° spacing;
- designed usually for unattended operation;
- antenna diameter not exceeding 3,8 m or equivalent corresponding aperture.

These VSATs comprise both the "outdoor unit", usually composed of the antenna subsystem and associated power amplifier and Low Noise Block (LNB), and the "indoor unit" composed of the remaining part of the communication chain, including the cable between these two units.

The present document applies to the VSAT with its ancillary equipment and its various terrestrial ports, and operated under the conditions which are within the ranges of humidity, temperature and supply voltage intended use.

B.2 Receive-only Ku band VSATs

The present document applies to receive-only Very Small Aperture Terminals (VSATs) operating as part of a satellite network (e.g. star, meshed or point to point) used for the distribution of information.

These VSATs have the following characteristics:

- operating in the exclusive space-to-earth part of the Ku-band allocated to the Fixed Satellite Service (FSS), 12,50 GHz to 12,75 GHz (Space-Earth), and/or in the shared parts of the Ku-band, allocated to the FSS and Fixed Services (FS), 10,70 GHz to 11,70 GHz (Space-Earth);
- in these frequency bands linear polarization is normally used and the system operates through satellites at 3° spacing;
- designed usually for unattended operation;
- antenna diameter not exceeding 3,8 m or equivalent corresponding aperture.

These VSATs comprise both the "outdoor unit", usually composed of the antenna subsystem and associated Low Noise Block (LNB), and the "indoor unit" composed of the remaining part of the communication chain, including the cable between these two units.

The present document applies to the VSAT with its ancillary equipment and its various terrestrial ports, and operated under the conditions which are within the ranges of humidity, temperature and supply voltage intended use.

B.3 Transmit only and Transmit and receive C band VSATs

The present document applies to transmit only and also to transmit and receive Very Small Aperture Terminals (VSATs) operating as part of a satellite network (e.g. star, meshed or point to point) used for the distribution and/or exchange of information between users.

In such a network a Centralized Control and Monitoring Functions (CCMF) is responsible for the monitoring and control of VSATs.

These VSATs have the following characteristics:

- operating in the exclusive part of the C-band allocated to the Fixed Services (FS) and to the Fixed Satellite Services (FSSs), 5,850 GHz to 6,425 GHz (Earth-Space), 3,625 GHz to 4,200 GHz (Space-Earth);
- in these frequency bands circular and linear polarizations are used and the system operates through satellites at 3° spacing;
- designed usually for unattended operation;
- antenna diameter not exceeding 7,3 m or equivalent corresponding aperture.

These VSATs comprise both the "outdoor unit", usually composed of the antenna subsystem and associated power amplifier and Low Noise Block (LNB), and the "indoor unit" composed of the remaining part of the communication chain, including the cable between these two units.

The present document applies to the VSAT with its ancillary equipment and its various terrestrial ports, and operated under the conditions which are within the ranges of humidity, temperature and supply voltage intended use.

B.4 Receive-only C band VSATs

The present document applies to receive-only Very Small Aperture Terminals (VSATs) operating as part of a satellite network (e.g. star, meshed or point to point) used for the distribution of information.

These VSATs have the following characteristics:

- operating in the exclusive part of the C-band allocated to the Fixed Services (FS) and to the Fixed Satellite Services (FSSs) 3,625 GHz to 4,200 GHz (Space-Earth);
- in these frequency bands circular and linear polarizations are used and the system operates through satellites at 3° spacing;
- designed usually for unattended operation;
- antenna diameter not exceeding 7,3 m or equivalent corresponding aperture.

These VSATs comprise both the "outdoor unit", usually composed of the antenna subsystem and associated Low Noise Block (LNB), and the "indoor unit" composed of the remaining part of the communication chain, including the cable between these two units.

The present document applies to the VSAT with its ancillary equipment and its various terrestrial ports, and operated under the conditions which are within the ranges of humidity, temperature and supply voltage intended use.

B.5 Satellite News Gathering (SNG) Ku band Transportable Earth Stations (TESs)

The present document applies to Transportable Earth Stations (TESs) used for Satellite News Gathering (SNG) which can be either an unforeseen or pre-planned activity. The SNG TES is capable of transmitting television signals and associated audio or programme audio only towards a satellite positioned on the geostationary orbit. The modulation method may be either analogue or digital. Such transmissions are point-to-point or point-to-multipoint but not for general broadcast reception.

A Transportable Earth Station (TES) is an Earth Station that can be relocated at any time to a different fixed operating location but is not intended to operate during the relocation period. The TES can be either vehicle mounted or packed for transportation. The TESs considered in the present document are those designed to operate whilst stationary.

This Earth Station should include a capability to receive from the satellite for antenna pointing purposes and to monitor its own transmission where the satellite transmission beam permits. The receive equipment could also be used in the process of the two-way communication to control and co-ordinate operation.

These TESs have the following characteristics:

- operating in the exclusive part of the Ku-band allocated to the Fixed Satellite Services (FSSs), 12,75 GHz to 13,25 GHz (Earth-Space), 13,75 GHz to 14,50 GHz (Earth-Space), 10,70 GHz to 11,70 GHz (Space-Earth), and/or 12,50 GHz to 12,75 GHz (Space-Earth). Frequencies could be selected from through the entire frequency range or be restricted to a range completely enclosed within those bands. These bands are partly shared between FSS and Fixed Service (FS);
- TES does not operate in any of the Mobile Satellite Service (MSS), e.g. LMSS (Land), AMSS (Aeronautical) and MMSS (Maritime). These are referred to as mobile Earth Stations;
- in these frequency bands linear polarization is normally used and the system operates through satellites with 3° spacing;
- designed for attended operation;
- antenna diameter not exceeding 5 m or equivalent corresponding aperture.

NOTE: At present the ITU Radio Regulations [i.13] restrict the use of the 13,75 GHz to 14,00 GHz band to Earth Stations having an antenna diameter of 4,5 m or greater and having a transmitting EIRP between 68 dBW and 85 dBW.

These SNG TESs comprise both the antenna sub-system and the associated transmit and receive sub-systems.

The present document does not contain any requirement, recommendation or information about the method of modulation. Such modulation could result in the transmission being either analogue or digital or both simultaneously.

The present document does not contain any requirement, recommendation or information about the baseband signals used in the modulation process. Such baseband signals could be pure analogue, digital or a mixture of analogue and digital.

B.6 Satellite Interactive Terminals (SITs)

The present document applies to the SIT in all its operational conditions, with its ancillary equipment and its various ports and when operated under the conditions which are within the range of humidity, temperature, and supply voltage intended use.

These SITs are used for reception of audio-visual signals as well as data and for providing a return channel for interactive services via satellite.

In such a network a Network Control Facility (NCF) is responsible for the monitoring and control of the transmit functions of the SITs.

These SITs have the following characteristics:

- reception is in the Fixed Satellite Service (FSS) frequency ranges from 10,70 GHz to 11,70 GHz and from 12,50 GHz to 12,75 GHz as well as the Broadcast Satellite Service (BSS) frequency range from 11,70 GHz to 12,50 GHz;
- transmission is in the frequency band allocated to FSS on a primary basis from 29,5 GHz to 30,0 GHz;
- these SITs transmit through geostationary satellites with spacings down to 2° away from any other geostationary satellite operating in the same frequency band and covering the same area;
- linear or circular polarization is used for transmission or reception;
- the received signals may be analogue and/or digital;
- transmitted signals are always of digital nature;
- the SIT antenna diameter does not exceed 1,8 m or equivalent corresponding aperture;
- the SIT is designed for unattended operations.

The equipment considered in the present document comprises both the outdoor unit, usually composed of the antenna subsystem and associated upconverter, power amplifier and Low Noise Block (LNB) downconverter, and the indoor unit, usually composed of receive and transmit logic as well as the modulator, including cables between these two units.

B.7 Satellite User Terminals (SUTs) transmitting in the frequency range 29,5 GHz to 30,0 GHz

The present document applies to the SUT in all its operational conditions with its ancillary equipment and its various ports and when operated under the conditions which are within the range of humidity, temperature and supply voltage intended use.

These SUTs are used mainly for transmission and reception of data signals.

In such a network a Network Control Facility (NCF) is responsible for the monitoring and control of the transmit functions of the SUTs.

These SUTs have the following characteristics:

- reception is in the frequency band allocated to the Fixed Satellite Service (FSS) on a primary basis from 19,70 GHz to 20,20 GHz;
- transmission is in the frequency band allocated to the Fixed Satellite Service (FSS) on a primary basis from 29,5 GHz to 30,0 GHz;

- these SUTs transmit through geostationary satellites with spacing down to 2° away from any other geostationary satellite operating in the same frequency band and covering the same area;
- linear or circular polarization is used for transmission or reception;
- the received signals may be analogue and/or digital;
- transmitted signals are always of digital nature;
- the SUT antenna diameter does not exceed 1,8 m or equivalent corresponding aperture;
- the SUT is designed for unattended operations.

The equipment considered in the present document comprises both the outdoor unit, usually composed of the antenna subsystem and associated upconverter, power amplifier and Low Noise Block (LNB) downconverter, and the indoor unit, usually composed of receive and transmit logic as well as the modulator, including the cable between these two units.

B.8 Satellite User Terminals (SUTs) transmitting in the frequency range 27,5 GHz to 29,5 GHz

The present document applies to the SUT in all its operational conditions with its ancillary equipment and its various ports and when operated under the conditions which are within the range of humidity, temperature and supply voltage intended use.

These SUTs are used mainly for transmission and reception of data signals.

In such a network a Network Control Facility (NCF) is responsible for the monitoring and control of the transmit functions of the SUTs.

These SUTs have the following characteristics:

- reception is in the frequency band allocated to the Fixed Satellite Service (FSS) from 17,70 GHz to 19,70 GHz;
- transmission is in the frequency band allocated to the Fixed Satellite Service (FSS) from 27,5 GHz to 29,5 GHz;
- these SUTs transmit through geostationary satellites with spacing down to 2° away from any other geostationary satellite operating in the same frequency band and covering the same area;
- linear or circular polarization is used for transmission and reception;
- the received signals may be analogue and/or digital;
- transmitted signals are always of digital nature;
- the SUT antenna diameter does not exceed 1,8 m or equivalent corresponding aperture;
- the SUT is designed for unattended operations.

The equipment considered in the present document comprises both the outdoor unit, usually composed of the antenna subsystem and associated upconverter, power amplifier and Low Noise Block (LNB) downconverter, and the indoor unit, usually composed of receive and transmit logic as well as the modulator, including the cable between these two units.

B.9 Satellite Earth Station on Trains (EST) transmitting in the frequency range 14,0 GHz to 14,5 GHz

The present document applies to the EST in all its operational conditions with its ancillary equipment and its various ports and when operated under the conditions which are within the range of humidity, temperature and supply voltage intended use.

These ESTs are used mainly for transmission and reception of data signals.

In such a network a Network Control Facility (NCF) is responsible for the monitoring and control of the transmit functions of the ESTs.

These ESTs have the following characteristics:

- The EST is comprised of all the equipment, electrical and mechanical, from the antenna itself to the interface with other communications equipment on a train (usually referred to as the terrestrial interface).
- The EST transmits on single carrier in the frequency range 14,00 GHz to 14,25 GHz, which is a portion of a band allocated to the Fixed Satellite Services (FSSs) (Earth to space).
- The EST receives in one or more frequencies within the range from 10,70 GHz to 12,75 GHz in bands allocated to the Fixed Satellite Services (FSSs) (space to Earth) or the Broadcast Satellite Service (BSS) (space-to-Earth), depending on the ITU Region [i.13] where the EST is located.
- The EST is designed to operate through a geostationary satellite (or a cluster of co-located geostationary satellites) that is at least 3° away from any other geostationary satellite operating in the same frequencies and over the same coverage area.
- Transmitted and received signals are always of digital nature.
- The EST may transmit and receive data when the train is in motion and also when the train is stationary.
- The EST operates in a railway environment and, therefore, may be subject to occasional disturbances and interruptions in the satellite link.
- The EST is operating as part of a satellite network (e.g. star, mesh or point to point) used for the distribution and/or exchange of information.
- The EST uses linear or circular polarization.
- The EST transmits at elevations greater than or equal to 7° relative to the local horizon.
- The EST is designed for unattended operation.

The equipment considered in the present document comprises both the Externally Mounted Equipment (EME), usually composed of the antenna subsystem and associated upconverter, power amplifier and Low Noise Block (LNB) downconverter, and the Internally Mounted Equipment (IME), usually composed of receive and transmit logic as well as the modulator, including the cable between these two units.

B.10 Earth Stations On Mobile Platforms (ESOMP) transmitting in the frequency range 27,5 GHz to 30,0 GHz

The present document applies to Earth Stations On Mobile Platforms (ESOMP), which have the following characteristics:

- The ESOMP is designed for both mobile and stationary operations.
- The ESOMP operates on various mobile platforms such as trains, maritime vessels, aircraft and other vehicles.

- The ESOMP is operating as part of a satellite network (e.g. star, mesh or point-to-point) used for the distribution and/or exchange of information.
- The ESOMP is comprised of all the equipment, electrical and mechanical, from the antenna itself to the interface with other communications equipment on a mobile platform (usually referred to as the terrestrial interface).
- The ESOMP transmits within the frequency range from 27,50 GHz to 30,00 GHz, which is a band allocated to the Fixed Satellite Services (FSSs) (Earth-to-space) among other services.
- The ESOMP receives in one or more frequencies within the range from 17,30 GHz to 20,20 GHz (FSS).
- The ESOMP uses linear or circular polarization.
- The ESOMP operates through a geostationary satellite (or a cluster of co-located geostationary satellites) that is at least 2° away from any other geostationary satellite operating in the same frequencies and over the same coverage area.
- The ESOMP is designed for unattended operation.
- The ESOMP is controlled and monitored by a Network Control Facility (NCF). This function may be performed centrally (e.g. for a network of ESOMPs with a central hub) or it could be performed within the ESOMP for autonomous control. The NCF is outside the scope of the present document.

Annex C (informative): Bibliography

- Council Directive 89/336/EEC of 3 May 1989 on the approximation of the laws of the Member States relating to electromagnetic compatibility (EMC Directive).
- Council Directive 73/23/EEC of 19 February 1973 on the harmonization of the laws of Member States relating to electrical equipment designed for use within certain voltage limits (LV Directive).
- ETSI EG 203 336: "Guide for the selection of technical parameters for the production of Harmonised Standards covering article 3.1(b) and article 3.2 of Directive 2014/53/EU".
- ERC/DEC(00)07: "ERC Decision of 19 October 2000 on the shared use of the band 17.7 - 19.7 GHz by the fixed service and Earth stations of the fixed-satellite service (space-to-Earth)".

Annex D (informative): Change history

Version	Information about changes
3.1.1	Updated for RED compliance
3.1.2	Alignment with EC feedback and the mapping of requirements with ETSI EN 301 489-1 (V2.2.3)

History

Document history		
V1.1.1	December 2000	Publication
V1.2.1	May 2003	Publication
V2.2.2	September 2008	Publication
V3.1.1	April 2019	Publication
V3.1.2	March 2021	EN Approval Procedure AP 20210622: 2021-03-24 to 2021-06-22