

Draft **ETSI EN 301 489-12** V1.1.1 (2000-07)

Candidate Harmonized European Standard (Telecommunications series)

**Electromagnetic compatibility
and Radio spectrum Matters (ERM);
ElectroMagnetic Compatibility (EMC)
standard for radio equipment and services;
Part 12: Specific conditions for Very Small Aperture
Terminal, Satellite Interactive Earth Stations operated
in the frequency ranges between 4 GHz and 30 GHz
in the Fixed Satellite Service (FSS)**



Reference

DEN/ERM-EMC-219-12

KeywordsEMC, radio, earth station, regulation, satellite,
testing, FSS, VSAT, SNG**ETSI**

650 Route des Lucioles
F-06921 Sophia Antipolis Cedex - FRANCE

Tel.: +33 4 92 94 42 00 Fax: +33 4 93 65 47 16

Siret N° 348 623 562 00017 - NAF 742 C
Association à but non lucratif enregistrée à la
Sous-Préfecture de Grasse (06) N° 7803/88

Important notice

Individual copies of the present document can be downloaded from:

<http://www.etsi.org>

The present document may be made available in more than one electronic version or in print. In any case of existing or perceived difference in contents between such versions, the reference version is the Portable Document Format (PDF).

In case of dispute, the reference shall be the printing on ETSI printers of the PDF version kept on a specific network drive within ETSI Secretariat.

Users of the present document should be aware that the document may be subject to revision or change of status.

Information on the current status of this and other ETSI documents is available at <http://www.etsi.org/tb/status/>

If you find errors in the present document, send your comment to:

editor@etsi.fr

Copyright Notification

No part may be reproduced except as authorized by written permission.
The copyright and the foregoing restriction extend to reproduction in all media.

© European Telecommunications Standards Institute 2000.
All rights reserved.

Contents

Intellectual Property Rights	5
Foreword	5
1 Scope	7
2 References	7
3 Definitions and abbreviations	8
3.1 Definitions	8
3.2 Abbreviations	8
4 Test conditions	8
4.1 General	8
4.2 Arrangements for test signals	9
4.2.1 Arrangements for test signals at the input of transmitters	9
4.2.2 Arrangements for test signals at the output of transmitters	9
4.2.3 Arrangements for test signals at the input of receivers	9
4.2.4 Arrangements for test signals at the output of receivers	9
4.2.5 Arrangements for testing transmitter and receiver together (as a system).....	9
4.3 Exclusion bands.....	9
4.4 Narrow band responses of receivers	9
5 Performance assessment.....	10
5.1 General	10
5.2 Equipment configuration(s)	10
5.3 Equipment classification.....	11
6 Performance criteria.....	11
6.1 Performance criteria (C) for Continuous phenomena applied to the EUT.....	11
6.2 Performance criteria (TA) for Transient phenomena applied to a grade A EUT.....	12
6.3 Performance criteria (TB) for Transient phenomena applied to a grade B EUT	12
7 Applicability overview.....	13
7.1 Emission.....	13
7.1.1 General.....	13
7.1.2 Special conditions.....	13
7.2 Immunity	13
7.2.1 General.....	13
7.2.2 Special conditions.....	13

Annex A (normative):	Definitions of Satellite Earth Stations (ES) within the scope of the present document.....	15
A.1	Transmit only and Transmit and receive Ku band VSATs.....	15
A.2	Receive-only Ku band VSATs.....	15
A.3	Transmit only and Transmit and receive C band VSATs	16
A.4	Receive-only C band VSATs	16
A.5	Satellite News Gathering (SNG) Ku band Transportable Earth Stations (TESs).....	17
A.6	Satellite Interactive Terminals (SITs).....	17
A.7	Satellite User Terminals (SUTs) transmitting in the frequency range 29,5 GHz to 30,0 GHz.....	18
A.8	Satellite User Terminals (SUTs) transmitting in the frequency range 27,5 GHz to 29,5 GHz.....	19
	Bibliography	20
	History	21

Intellectual Property Rights

IPRs essential or potentially essential to the present document may have been declared to ETSI. The information pertaining to these essential IPRs, if any, is publicly available for **ETSI members and non-members**, and can be found in ETSI SR 000 314: *"Intellectual Property Rights (IPRs); Essential, or potentially Essential, IPRs notified to ETSI in respect of ETSI standards"*, which is available from the ETSI Secretariat. Latest updates are available on the ETSI Web server (<http://www.etsi.org/ipr>).

Pursuant to the ETSI IPR Policy, no investigation, including IPR searches, has been carried out by ETSI. No guarantee can be given as to the existence of other IPRs not referenced in ETSI SR 000 314 (or the updates on the ETSI Web server) which are, or may be, or may become, essential to the present document.

Foreword

This Candidate Harmonized European Standard (Telecommunications series) has been produced by ETSI Technical Committee Electromagnetic compatibility and Radio spectrum Matters (ERM), and is now submitted for the ETSI standards One-step Approval Procedure.

The present document has been produced by ETSI in response to a mandate from the European Commission issued under Council Directive 98/34/EC [4] (as amended) laying down a procedure for the provision of information in the field of technical standards and regulations.

The present document, together with EN 301 489-1 [1], is intended to become a Harmonized EMC Standard, the reference of which will be published in the Official Journal of the European Communities referencing the Council Directive on the approximation of the laws of the Member States relating to electromagnetic compatibility (the "EMC Directive" 89/336/EEC [3] as amended), and the Council Directive on the approximation of the laws of the Member States relating to radio equipment and telecommunications terminal equipment and the mutual recognition of their conformity (the "R&TTE Directive" 1999/5/EC [2]).

The present document is part 12 of a multi-part deliverable covering the ElectroMagnetic Compatibility (EMC) standard for radio equipment and services, as identified below:

- Part 1: "Common technical requirements";
- Part 2: "Specific conditions for radio paging equipment";
- Part 3: "Specific conditions for Short-Range Devices (SRD) operating on frequencies between 9 kHz and 40 GHz";
- Part 4: "Specific conditions for fixed radio links and ancillary equipment and services";
- Part 5: "Specific conditions for Private land Mobile Radio (PMR) and ancillary equipment (speech and non-speech)";
- Part 6: "Specific conditions for Digital Enhanced Cordless Telecommunications (DECT) equipment";
- Part 7: "Specific conditions for mobile and portable radio and ancillary equipment of digital cellular radio telecommunications systems (GSM and DCS)";
- Part 8: "Specific requirements for GSM base stations";
- Part 9: "Specific conditions for wireless microphones and similar Radio Frequency (RF) audio link equipment";
- Part 10: "Specific conditions for First (CT1 and CT1+) and Second Generation Cordless Telephone (CT2) equipment";
- Part 11: "Specific conditions for FM broadcasting transmitters";
- Part 12: "Specific conditions for Earth Stations operated in the frequency ranges between 4 GHz and 30 GHz in the Fixed Satellite Service (FSS)";**

- Part 13: "Specific conditions for Citizens' Band (CB) radio and ancillary equipment (speech and non-speech)";
- Part 15: "Specific conditions for commercially available amateur radio equipment";
- Part 16: "Specific conditions for analogue cellular radio communications equipment, mobile and portable";
- Part 17: "Specific requirements for Wideband data and HIPERLAN";
- Part 18: "Specific requirements for Terrestrial Trunked Radio (TETRA)";
- Part 19: "Specific conditions for Receive Only Mobile Earth Stations (ROMES) operating in the 1,5 GHz band providing data communications";
- Part 20: "Specific conditions for Mobile Earth Stations (MES) used in the Mobile Satellite Services (MSS)";
- Part 22: "Specific requirements for VHF aeronautical mobile and fixed radios".

Proposed national transposition dates	
Date of latest announcement of this EN (doa):	3 months after ETSI publication
Date of latest publication of new National Standard or endorsement of this EN (dop/e):	6 months after doa
Date of withdrawal of any conflicting National Standard (dow):	36 months after doa

1 Scope

The present document, together with EN 301 489-1 [1], covers the assessment of Earth Stations (ES) operated in the frequency ranges between 4 GHz and 30 GHz in the Fixed Satellite Service (FSS) as defined in annex A in respect of Electromagnetic Compatibility (EMC).

Technical specifications related to the antenna port and emissions from the enclosure port of the Earth Stations (ES) are not included in the present document. Such technical specifications are found in the relevant product standards for the effective use of the radio spectrum.

The present document specifies the applicable test conditions, performance assessment and the performance criteria for the ESs, and associated ancillary equipment.

In case of differences (for instance concerning special conditions, definitions, abbreviations) between the present document and EN 301 489-1 [1], the provisions of the present document take precedence.

The environmental classification and the emission and immunity requirements used in the present document are as stated in EN 301 489-1 [1], except for any special conditions included in the present document. The applicable environments referred to in EN 301 489-1 [1] where equipment covered by the scope of the present document may be used, shall be declared by the manufacturer.

2 References

The following documents contain provisions which, through reference in this text, constitute provisions of the present document.

- References are either specific (identified by date of publication, edition number, version number, etc.) or non-specific.
- For a specific reference, subsequent revisions do not apply.
- For a non-specific reference, the latest version applies.
- A non-specific reference to an ETS shall also be taken to refer to later versions published as an EN with the same number.

- [1] ETSI EN 301 489-1: "Electromagnetic compatibility and Radio spectrum Matters (ERM); ElectroMagnetic Compatibility (EMC) standard for radio equipment and services; Part 1: Common technical requirements".
- [2] Directive 1999/5/EC of the European Parliament and of the Council of 9 March 1999 on radio equipment and telecommunications equipment and the mutual recognition of their conformity.
- [3] Council Directive 89/336/EEC of 3 May 1989 on the approximation of the laws of the Member States relating to electromagnetic compatibility.
- [4] Directive 98/34/EC of the European Parliament and of the Council of 22 June 1998 laying down a procedure for the provision of information in the field of technical standards and regulations.
- [5] EN 55022: "Limits and methods of measurement of radio disturbance characteristics of information technology equipment".

3 Definitions and abbreviations

3.1 Definitions

For the purposes of the present document, the terms and definitions given in EN 301 489-1 [1] and the following apply:

carrier-on state: transmit ES is in this state when it is authorized to transmit, and when it transmits a signal, either authorized by a Centralized Control and Monitoring Function (CCMF) or a Network Control Facility (NCF) when designed for unattended operation or by local control when designed for attended operation

carrier-off state: transmit ES is in this state when it is authorized to transmit, and when it does not transmit any signal, either authorized by a CCMF or a NCF when designed for unattended operation or by local control when designed for attended operation.

NOTE: The existence of a carrier-off state depends on the system of transmission used. For ES designed for continuous transmission mode there may be no carrier-off state.

transmission disabled state: transmit ES is in this state when it is not authorized to transmit either by a CCMF or a NCF respectively when designed for unattended operation or by local control when designed for attended operation

3.2 Abbreviations

For the purposes of the present document, the following abbreviations apply:

CCMF	Centralized Control and Monitoring Functions
CMF	Control and Monitoring Functions
EIRP	Equivalent Isotropically Radiated Power
EMC	ElectroMagnetic Compatibility
ES	Earth Station
EUT	Equipment Under Test
FSS	Fixed Satellite Service
LNB	Low Noise Block converter
NCF	Network Control Facility
QTMA	Quality of Transmission Measurement Apparatus
RF	Radio Frequency
SIT	Satellite Interactive Terminals
SNG	Satellite News Gathering
SUT	Satellite User Terminals
TES	Transportable Earth Station
VSAT	Very Small Aperture Terminal

4 Test conditions

For the purposes of the present document, the test conditions of EN 301 489-1 [1], clause 4 shall apply as appropriate. Further product type related test conditions for Earth Stations are specified in the present document.

4.1 General

For Earth Stations with or without ancillary equipment, and/or various terrestrial ports, the number of test configurations shall be determined. The assessment shall include sufficient representative configurations of the ES to adequately exercise the equipment. These configurations shall be recorded in the test report.

In the following clauses, the Equipment Under Test (EUT) is an ES with the selected configuration of ancillary equipment.

4.2 Arrangements for test signals

The provisions of EN 301 489-1 [1], subclause 4.2 shall apply with the following modifications.

In order to measure the unwanted emissions and electromagnetic immunity under operational conditions, the following arrangements shall be provided by the manufacturer:

- a) a special test equipment to put the ES terminal in its normal operating mode, and providing the ES with a receive signal to emulate the operational conditions of reception. This equipment shall control the EUT, when it is capable of transmission, so that it switches between the transmission disabled, carrier-on and carrier-off states;
- b) the specific Quality of Transmission Measurement Apparatus (QTMA).

For the measurement of the quality of transmission a communications link shall be established and the wanted input signal shall be applied to the Radio Frequency (RF) input of the receiver via the antenna.

The special test equipment, the QTMA and the source of the wanted input signal shall be located outside the test environment. Adequate measures shall be taken to protect them from the effects of all the radiated fields within the test environment.

4.2.1 Arrangements for test signals at the input of transmitters

The provisions of EN 301 489-1 [1], subclause 4.2.1 shall apply.

4.2.2 Arrangements for test signals at the output of transmitters

The provisions of EN 301 489-1 [1], subclause 4.2.2 shall apply.

4.2.3 Arrangements for test signals at the input of receivers

The provisions of EN 301 489-1 [1], subclause 4.2.3 shall apply with the following modification.

For tests on the receiver, the level of the signal received from the test transmitter shall be as close as possible to the normal operation level of the EUT receiver.

4.2.4 Arrangements for test signals at the output of receivers

The provisions of EN 301 489-1 [1], subclause 4.2.4 shall apply.

4.2.5 Arrangements for testing transmitter and receiver together (as a system)

The provisions of EN 301 489-1 [1], subclause 4.2.5 shall apply.

4.3 Exclusion bands

There are no exclusion bands for ESs within in the scope of the present document.

4.4 Narrow band responses of receivers

Narrow band responses are not allowed for ESs within in the scope of the present document.

5 Performance assessment

5.1 General

The provision of EN 301 489-1 [1], subclause 5.1 shall apply.

In addition the manufacturer shall provide the following information to be recorded in the test report:

- the dedicated grade (A or B) for the ES in accordance with the information contained in the instructions accompanying the ES (see subclause 5.3);
- the ranges of the operational parameters, e.g. the power delivered to the antenna, the frequency ranges;
- the minimum quality of transmission, and the method to be used to assess it.

This information shall be in accordance with the documentation accompanying the equipment.

5.2 Equipment configuration(s)

For radiation measurements in carrier-on state, the ES shall be put in a continuous transmit mode or to the maximum burst rate where applicable. The ES shall be operated at the highest normal operating Equivalent Isotropically Radiated Power (EIRP) or, if that is the maximum attainable, then 3 dB below such maximum.

A suggested test configuration is shown in figure 1.

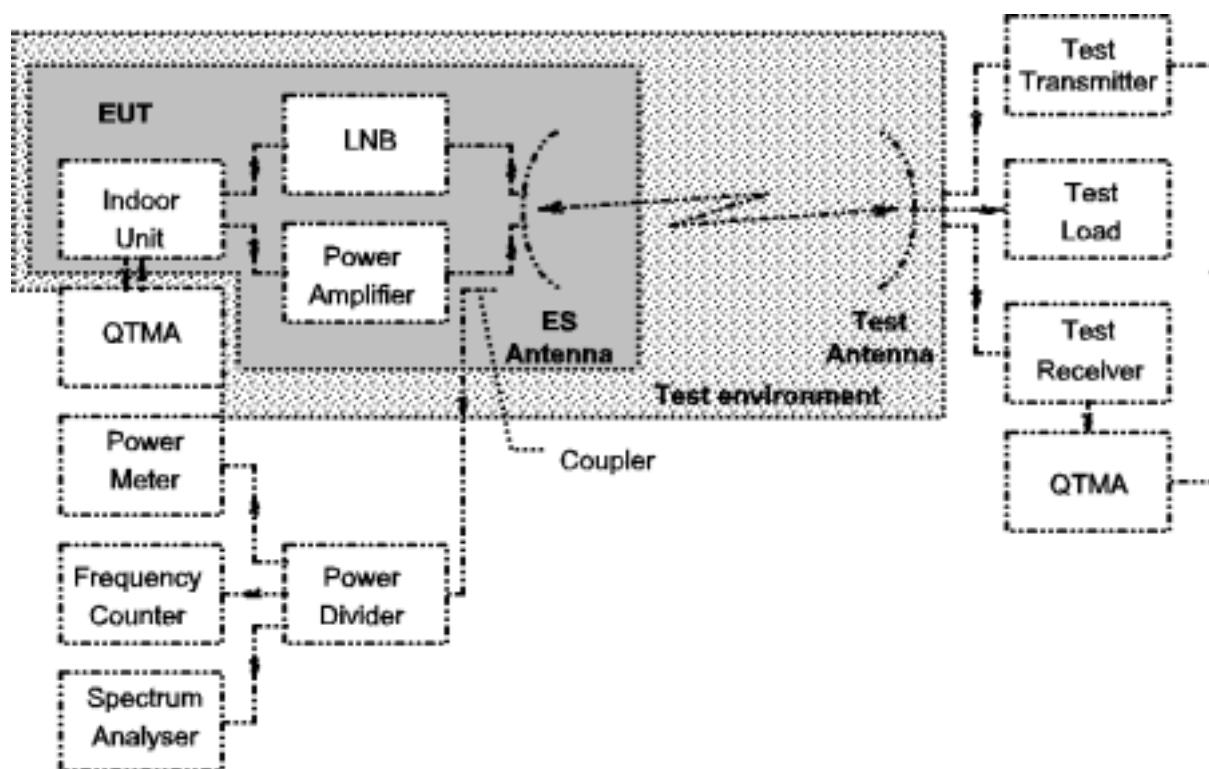

Figure 1: Suggested test configuration

For the tests, the ES antenna reflector and the test antenna may be removed at their flanges and be replaced by one direct wave guide connection.

The following test equipment shall be the means whereby the correct operation of the EUT is verified:

- a) the power meter measures the output power and is used to confirm the transmission disabled, carrier-on and carrier-off states and output level consistency;
- b) the frequency counter measures the centre frequency of the radiated carrier in the absence of modulation;
- c) the spectrum analyser measures the bandwidth of the transmission;
- d) the test receiver is used to demodulate the transmitted signal;
- e) the two QTMA are used in conjunction with each other to assess the quality of transmission;
- f) the test transmitter is used to control the switching between transmission disabled, carrier-on and carrier-off states by transmitting the control and monitoring signals.

5.3 Equipment classification

The provisions of EN 301 489-1 [1], subclause 5.5 set out for base stations shall apply with the following addition.

The equipment are classified into the two grades of service:

- grade A of ES for which short interruptions of transmission are accepted during immunity testing with EMC transient phenomena;
- grade B of ES for which no short interruption of transmission is accepted during immunity testing with EMC transient phenomena.

The applicable grade A or B shall be declared by the manufacturer, it shall be in accordance with the information contained in the instructions accompanying the ES, and shall be recorded in the test report.

6 Performance criteria

The definition of the functions of the EUT, including its ancillary equipment, to be checked during and after the EMC tests shall be declared by the manufacturer and recorded in the test report.

The equipment shall meet the minimum performance criteria as specified in subclauses 6.1, 6.2 and 6.3 and additionally the functions as declared by the manufacturer.

6.1 Performance criteria (C) for Continuous phenomena applied to the EUT

The provisions of EN 301 489-1 [1], subclause 6.1 shall apply with the following modification.

The EUT shall be considered to satisfy the immunity if the following conditions are met during and after the exposure:

- a) the quality of transmission observed is no worse than that declared by the manufacturer (subclause 5.1);
- b) the EUT is able to be placed in the transmission disabled state, and does not leave that state without being commanded;
- c) when the EUT is in the transmission disabled state there is no change in the signal level;
- d) when the EUT is in the carrier-on state there is no change in the signal level or frequency;
- e) when the EUT is in the carrier-off state there is no increase of the signal level;
- f) for ESs capable of transmitting, under no circumstances does the transmitter operate unintentionally during the test;
- g) the EUT operates as intended with no loss of user control functions, stored data and the communications link.

6.2 Performance criteria (TA) for Transient phenomena applied to a grade A EUT

The provisions of EN 301 489-1 [1], subclause 6.2 shall apply with the following modification.

The EUT shall be considered to satisfy the immunity specifications if the following conditions are met:

- during and after the series of individual exposures:
 - a) the EUT is able to be placed in the transmission disabled state, and does not leave that state without being commanded;
 - b) when the EUT is in the transmission disabled state there is no change in the signal level;
 - c) when the EUT is in the carrier-on state there is no change in the signal frequency or increase of the signal level;
 - d) when the EUT is in the carrier-off state there is no increase of the signal level;
 - e) for ESs capable of transmitting, under no circumstances does the transmitter operate unintentionally during the test;
- at the conclusion of each exposure the quality of transmission observed shall be no worse than that declared by the manufacturer (subclause 5.1);
- at the conclusion of the total test comprising the series of individual exposures the EUT shall operate as intended with no loss of user control functions or stored data and the communications link shall remain maintained.

6.3 Performance criteria (TB) for Transient phenomena applied to a grade B EUT

The provisions of EN 301 489-1 [1], subclause 6.2 shall apply with the following modification.

The EUT shall be considered to satisfy the immunity specifications if the following conditions are met during and after the series of individual exposures:

- a) the quality of transmission observed is no worse than that declared by the manufacturer (subclause 5.1);
- b) under the test conditions the EUT is able to be placed in the transmission disabled state, and does not leave that state without being commanded;
- c) when the EUT is in the transmission disabled state there is no change in the signal level;
- d) when the EUT is in the carrier-on state there is no change in the signal level or frequency;
- e) when the EUT is in the carrier-off state there is no increase of the signal level;
- f) for ESs capable of transmitting, under no circumstances does the transmitter operate unintentionally during the test;
- g) the EUT shall operate as intended with no loss of user control functions, stored data and the communications link.

7 Applicability overview

7.1 Emission

7.1.1 General

EN 301 489-1 [1], table 2, contains the applicability of EMC emission measurements to the relevant ports of radio and/or associated ancillary equipment.

7.1.2 Special conditions

The following special conditions set out in table 1, relate to the emission test methods used in EN 301 489-1 [1], clause 8.

Table 1: Special conditions for EMC emission measurements

Reference to subclauses in EN 301 489-1 [1]	Special product-related conditions, additional to or modifying the test conditions in EN 301 489-1 [1], clause 8
<p>8.2.3 Limits; Enclosure of ancillary equipment measured on a stand alone basis</p>	<p>The requirements for radiated emission from the enclosure port, according to EN 55022 [5], is applicable to the complete system.</p> <p>The transmit carrier frequency and the receive carrier frequency shall be selected so that they give the maximum spurious radiation at frequencies below 1 000 MHz.</p>

7.2 Immunity

7.2.1 General

EN 301 489-1 [1], table 3, contains the applicability of EMC immunity measurements to the relevant ports of radio and/or associated ancillary equipment.

7.2.2 Special conditions

The following special conditions set out in table 2, relate to the immunity test methods and performance criteria used in EN 301 489-1 [1], clause 9.

Table 2: Special conditions for EMC immunity tests

Reference to subclauses in EN 301 489-1 [1]	Special product-related conditions, additional to or modifying the test conditions in EN 301 489-1 [1], clause 9
9.3.3 Performance criteria; Electrostatic discharge	The performance criteria TA (subclause 6.3) shall apply to grade A ES. The performance criteria TB (subclause 6.4) shall apply to grade B ES
9.4.3 Performance criteria; Fast transient, common mode	The performance criteria TA (subclause 6.3) shall apply to grade A ES. The performance criteria TB (subclause 6.4) shall apply to grade B ES
9.8.3 Performance criteria; Surges	The performance criteria TA (subclause 6.3) shall apply to grade A ES. The performance criteria TB (subclause 6.4) shall apply to grade B ES
9.7.3 Performance criteria; Voltage dips and interruptions	<p>a) for a voltage dip corresponding to a reduction of the supply voltage of 30 % for 10 ms, the performance criteria C (subclause 6.2) shall apply;</p> <p>b) for a voltage dip corresponding to a reduction of the supply voltage of 60 % for 100 ms, the performance criteria TA (subclause 6.3) shall apply to grade A ES, and the performance criteria TB (subclause 6.4) shall apply to grade B ES.</p> <p>c) For a voltage interruption corresponding to a reduction of the supply voltage of more than 95 % for 5 000 ms, the following performance criteria shall apply:</p> <ul style="list-style-type: none"> - for equipment fitted with or connected to a battery back-up the performance criteria TA (subclause 6.3) shall apply to both grade A and grade B ES;

Annex A (normative): Definitions of Satellite Earth Stations (ES) within the scope of the present document

The present document covers types of ES radio equipment as set out in the following clauses.

A.1 Transmit only and Transmit and receive Ku band VSATs

The present document applies to transmit only and also to transmit and receive Very Small Aperture Terminals (VSATs) operating as part of a satellite network (e.g. star, meshed or point to point) used for the distribution and/or exchange of information between users.

In such a network a Centralized Control and Monitoring Functions (CCMF) is responsible for the monitoring and control of VSATs.

These VSATs have the following characteristics:

- operating in the exclusive part of the Ku-band allocated to the Fixed Satellite Services (FSS), 14,00 GHz to 14,25 GHz (Earth-Space), 12,50 GHz to 12,75 GHz (Space-Earth), and/or in the shared parts of the Ku-band, allocated to the FSS and Fixed Services (FS), 14,25 GHz to 14,50 GHz (Earth-Space) and/or 10,70 GHz to 11,70 GHz (Space-Earth);
- in these frequency bands linear polarization is normally used and the system operates through satellites at 3° spacing;
- designed usually for unattended operation;
- antenna diameter not exceeding 3,8 m, or equivalent corresponding aperture.

These VSATs comprise both the "outdoor unit", usually composed of the antenna subsystem and associated power amplifier and Low Noise Block (LNB), and the "indoor unit" composed of the remaining part of the communication chain, including the cable between these two units.

The present document applies to the VSAT with its ancillary equipment and its various terrestrial ports, and operated under the conditions which are within the ranges of humidity, temperature and supply voltage declared by the manufacturer.

A.2 Receive-only Ku band VSATs

The present document applies to receive-only Very Small Aperture Terminals (VSATs) operating as part of a satellite network (e.g. star, meshed or point to point) used for the distribution of information.

These VSATs have the following characteristics:

- operating in the exclusive space-to-earth part of the Ku-band allocated to the Fixed Satellite Service (FSS), 12,50 GHz to 12,75 GHz (Space-Earth), and/or in the shared parts of the Ku-band, allocated to the FSS and Fixed Service (FS), 10,70 GHz to 11,70 GHz (Space-Earth);
- in these frequency bands linear polarization is normally used and the system operates through satellites at 3° spacing;
- designed usually for unattended operation;
- antenna diameter not exceeding 3,8 m, or equivalent corresponding aperture.

These VSATs comprise both the "outdoor unit", usually composed of the antenna subsystem and associated Low Noise Block (LNB), and the "indoor unit" composed of the remaining part of the communication chain, including the cable between these two units.

The present document applies to the VSAT with its ancillary equipment and its various terrestrial ports, and operated under the conditions which are within the ranges of humidity, temperature and supply voltage declared by the manufacturer.

A.3 Transmit only and Transmit and receive C band VSATs

The present document applies to transmit only and also to transmit and receive Very Small Aperture Terminals (VSATs) operating as part of a satellite network (e.g. star, meshed or point to point) used for the distribution and/or exchange of information between users.

In such a network a Centralized Control and Monitoring Function (CCMF) is responsible for the monitoring and control of VSATs.

These VSATs have the following characteristics:

- operating in the exclusive part of the C-band allocated to the Fixed Services (FS) and to the Fixed Satellite Services (FSS), 5,850 GHz to 6,425 GHz (Earth-Space), 3,625 GHz to 4,200 GHz (Space-Earth);
- in these frequency bands circular and linear polarizations are used and the system operates through satellites at 3° spacing;
- designed usually for unattended operation;
- antenna diameter not exceeding 7,3 m, or equivalent corresponding aperture.

These VSATs comprise both the "outdoor unit", usually composed of the antenna subsystem and associated power amplifier and Low Noise Block (LNB), and the "indoor unit" composed of the remaining part of the communication chain, including the cable between these two units.

The present document applies to the VSAT with its ancillary equipment and its various terrestrial ports, and operated under the conditions which are within the ranges of humidity, temperature and supply voltage declared by the manufacturer.

A.4 Receive-only C band VSATs

The present document applies to receive-only Very Small Aperture Terminals (VSATs) operating as part of a satellite network (e.g. star, meshed or point to point) used for the distribution of information.

These VSATs have the following characteristics:

- operating in the exclusive part of the C-band allocated to the Fixed Services (FS) and to the Fixed Satellite Services (FSS) 3,625 GHz to 4,200 GHz (Space-Earth);
- in these frequency bands circular and linear polarizations are used and the system operates through satellites at 3° spacing;
- designed usually for unattended operation;
- antenna diameter not exceeding 7,3 m or equivalent corresponding aperture.

These VSATs comprise both the "outdoor unit", usually composed of the antenna subsystem and associated Low Noise Block (LNB), and the "indoor unit" composed of the remaining part of the communication chain, including the cable between these two units.

The present document applies to the VSAT with its ancillary equipment and its various terrestrial ports, and operated under the conditions which are within the ranges of humidity, temperature and supply voltage declared by the manufacturer.

A.5 Satellite News Gathering (SNG) Ku band Transportable Earth Stations (TESs)

The present document applies to Transportable Earth Stations (TESs) used for Satellite News Gathering (SNG) which can be either an unforeseen or pre-planned activity. The SNG TES is capable of transmitting television signals and associated audio or programme audio only towards a satellite positioned on the geostationary orbit. The modulation method may be either analogue or digital. Such transmissions are point-to-point or point-to-multipoint but not for general broadcast reception.

A Transportable Earth Station (TES) is an earth station that can be relocated at any time to a different fixed operating location but is not intended to operate during the relocation period. The TES can be either vehicle mounted or packet for transportation. The TESs considered in the present document are those designed to operate whilst stationary.

This earth station should include a capability to receive from the satellite for antenna pointing purposes and to monitor its own transmission where the satellite transmission beam permits. The receive equipment could also be used in the process of the two-way communication to control and co-ordinate operation.

These TESs have the following characteristics:

- operating in the exclusive part of the Ku-band allocated to the Fixed Satellite Services (FSS), 12,75 GHz to 13,25 GHz (Earth - Space), 13,75 GHz to 14,50 GHz (Earth-Space), 10,70 GHz to 11,70 GHz (Space-Earth), and/or 12,50 GHz to 12,75 GHz (Space-Earth). Frequencies could be selected from through the entire frequency range or be restricted to a range completely enclosed within those bands. These bands are partly shared between FSS and Fixed Service (FS).
- TES does not operate in any of the Mobile Satellite Service (MSS), e.g. LMSS (Land), AMSS (Aeronautical) and MMSS (Maritime). These are referred to as mobile earth stations;
- in these frequency bands linear polarization is normally used and the system operates through satellites with 3° spacing;
- designed for attended operation;
- antenna diameter not exceeding 5 m, or equivalent corresponding aperture.

NOTE: At present the Radio Regulations restrict the use of the 13,75 GHz to 14,00 GHz band to earth stations having an antenna diameter of 4,5 m or greater and having a transmitting EIRP between 68 dBW and 85 dBW.

These SNG TESs comprise both the antenna sub-system and the associated transmit and receive sub-systems.

The present document does not contain any requirement, recommendation or information about the method of modulation. Such modulation could result in the transmission being either analogue or digital or both simultaneously. The present document does not contain any requirement, recommendation or information about the baseband signals used in the modulation process. Such baseband signals could be pure analogue, digital or a mixture of analogue and digital.

A.6 Satellite Interactive Terminals (SITs)

The present document defines the minimum specifications of the technical characteristics of Satellite Interactive Terminals operating as part of a satellite network. These SITs are used for reception of audio-visual signals as well as data and for providing a return channel for interactive services via satellite.

In such a network a Network Control Facility (NCF) is responsible for the monitoring and control of the transmit functions of the SITs.

These SITs have the following characteristics:

- reception is in the Fixed Satellite Service (FSS) frequency ranges from 10,70 GHz to 11,70 GHz and from 12,50 GHz to 12,75 GHz as well as the Broadcast Satellite Service (BSS) frequency range from 11,70 GHz to 12,50 GHz;
- transmission is in the frequency band allocated to FSS on a primary basis from 29,5 GHz to 30,0 GHz;
- these SITs transmit through geostationary satellites with spacings down to 2° away from any other geostationary satellite operating in the same frequency band and covering the same area;
- linear or circular polarization is used for transmission or reception;
- the received signals may be analogue and/or digital;
- transmitted signals are always of digital nature;
- the SIT antenna diameter does not exceed 1,8 m or equivalent corresponding aperture;
- the SIT is designed for unattended operations.

The equipment considered in the present document comprises both the outdoor unit, usually composed of the antenna subsystem and associated upconverter, power amplifier and Low Noise Block (LNB) downconverter, and the indoor unit, usually composed of receive and transmit logic as well as the modulator, including cables between these two units.

The present document applies to the SIT in all its operational conditions, with its ancillary equipment and its various ports and when operated under the conditions which are within the range of humidity, temperature, and supply voltage declared by the manufacturer.

A.7 Satellite User Terminals (SUTs) transmitting in the frequency range 29,5 GHz to 30,0 GHz

The present document defines the minimum specifications of the technical characteristics of Satellite User Terminals (SUT) operating as part of a satellite network. These SUTs are used mainly for transmission and reception of data signals.

In such a network a Network Control Facility (NCF) is responsible for the monitoring and control of the transmit functions of the SUTs.

These SUTs have the following characteristics:

- reception is in the frequency band allocated to the Fixed Satellite Service (FSS) on a primary basis from 19,70 GHz to 20,20 GHz;
- transmission is in the frequency band allocated to the Fixed Satellite Service (FSS) on a primary basis from 29,5 GHz to 30,0 GHz;
- these SUTs transmit through geostationary satellites with spacing down to 2° away from any other geostationary satellite operating in the same frequency band and covering the same area;
- linear or circular polarization is used for transmission or reception;
- the received signals may be analogue and/or digital;
- transmitted signals are always of digital nature;
- the SUT antenna diameter does not exceed 1,8 m, or equivalent corresponding aperture;
- the SUT is designed for unattended operations.

The equipment considered in the present document comprises both the outdoor unit, usually composed of the antenna subsystem and associated upconverter, power amplifier and Low Noise Block (LNB) downconverter, and the indoor unit, usually composed of receive and transmit logic as well as the modulator, including the cable between these two units.

The present document applies to the SUT in all its operational conditions with its ancillary equipment and its various ports and when operated under the conditions which are within the range of humidity, temperature and supply voltage declared by the manufacturer.

A.8 Satellite User Terminals (SUTs) transmitting in the frequency range 27,5 GHz to 29,5 GHz

The present document defines the minimum specifications of the technical characteristics of Satellite User Terminals (SUT) operating as part of a satellite network. These SUTs are used mainly for transmission and reception of data signals.

In such a network a Network Control Facility (NCF) is responsible for the monitoring and control of the transmit functions of the SUTs.

These SUTs have the following characteristics:

- reception is in the frequency band allocated to the Fixed Satellite Service (FSS) from 17,70 GHz to 19,70 GHz;
- transmission is in the frequency band allocated to the Fixed Satellite Service (FSS) from 27,5 GHz to 29,5 GHz;
- these SUTs transmit through geostationary satellites with spacing down to 2° away from any other geostationary satellite operating in the same frequency band and covering the same area;
- linear or circular polarization is used for transmission and reception;
- the received signals may be analogue and/or digital;
- transmitted signals are always of digital nature;
- the SUT antenna diameter does not exceed 1,8 m, or equivalent corresponding aperture;
- the SUT is designed for unattended operations.

The equipment considered in the present document comprises both the outdoor unit, usually composed of the antenna subsystem and associated upconverter, power amplifier and Low Noise Block (LNB) downconverter, and the indoor unit, usually composed of receive and transmit logic as well as the modulator, including the cable between these two units.

The present document applies to the SUT in all its operational conditions with its ancillary equipment and its various ports and when operated under the conditions which are within the range of humidity, temperature and supply voltage declared by the manufacturer.

Bibliography

The following material, though not specifically referenced in the body of the present document (or not publicly available), gives supporting information.

- ETSI EN 301 428: "Satellite Earth Stations and Systems (SES); Harmonized EN for Very Small Aperture Terminal (VSAT); Transmit-only, transmit/receive or receive-only satellite earth stations operating in the 11/12/14 GHz frequency bands covering essential requirements under article 3.2 of the R&TTE directive".
- ETSI EN 301 430: "Satellite Earth Stations and Systems (SES); Harmonized EN for Satellite News Gathering Transportable Earth Stations (SNG TES) operating in the 11-12/13-14 GHz frequency bands covering essential requirements under article 3.2 of the R&TTE directive".
- ETSI EN 301 443: "Satellite Earth Stations and Systems (SES); Harmonized EN for Very Small Aperture Terminal (VSAT); Transmit-only, transmit-and-receive, receive-only satellite earth stations operating in the 4 GHz and 6 GHz frequency bands covering essential requirements under article 3.2 of the R&TTE directive".
- ETSI EN 301 459: "Satellite Earth Stations and Systems (SES); Harmonized EN for Satellite Interactive Terminals (SIT) and Satellite User Terminals (SUT) transmitting towards satellites in geostationary orbit in the 29,5 to 30,0 GHz frequency bands covering essential requirements under article 3.2 of the R&TTE Directive".
- ETSI EN 301 360: "Satellite Earth Stations and Systems (SES); Harmonized EN for Satellite User Terminals (SUT) transmitting towards satellites in geostationary orbit in the 27,5 to 29,5 GHz frequency bands covering essential requirements under article 3.2 of the R&TTE Directive".

History

Document history			
V1.1.1	July 2000	One-step Approval Procedure	OAP 20001117: 2000-07-19 to 2000-11-17