

# ETSI EN 301 489-7 V1.1.1 (2000-09)

---

*Candidate Harmonized European Standard (Telecommunications series)*

**ElectroMagnetic compatibility  
and Radio spectrum Matters (ERM);  
ElectroMagnetic Compatibility (EMC) standard  
for radio equipment and services;  
Part 7: Specific conditions for mobile and portable radio  
and ancillary equipment of digital cellular radio  
telecommunications systems (GSM and DCS)**

---



---

**Reference**

DEN/ERM-EMC-219-7

---

**Keywords**EMC, GSM, GSM\_Phase1, GSM\_Phase2,  
GSM\_Phase2\_Plus, radio, regulation**ETSI**

---

650 Route des Lucioles  
F-06921 Sophia Antipolis Cedex - FRANCE

Tel.: +33 4 92 94 42 00 Fax: +33 4 93 65 47 16

Siret N° 348 623 562 00017 - NAF 742 C  
Association à but non lucratif enregistrée à la  
Sous-Préfecture de Grasse (06) N° 7803/88

---

**Important notice**

Individual copies of the present document can be downloaded from:

<http://www.etsi.org>

The present document may be made available in more than one electronic version or in print. In any case of existing or perceived difference in contents between such versions, the reference version is the Portable Document Format (PDF). In case of dispute, the reference shall be the printing on ETSI printers of the PDF version kept on a specific network drive within ETSI Secretariat.

Users of the present document should be aware that the document may be subject to revision or change of status. Information on the current status of this and other ETSI documents is available at <http://www.etsi.org/tb/status/>

If you find errors in the present document, send your comment to:  
editor@etsi.fr

---

**Copyright Notification**

No part may be reproduced except as authorized by written permission.  
The copyright and the foregoing restriction extend to reproduction in all media.

© European Telecommunications Standards Institute 2000.  
All rights reserved.

# Contents

Intellectual Property Rights .....	5
Foreword.....	5
1 Scope .....	7
2 References .....	7
3 Definitions and abbreviations.....	8
3.1 Definitions .....	8
3.2 Abbreviations .....	8
4 Test conditions .....	9
4.1 General .....	9
4.2 Arrangements for test signals .....	9
4.2.1 Arrangements for establishing a communications link .....	9
4.2.1.1 Calibration of the overall audio link performance .....	9
4.2.1.2 Measurement of the audio level at the speech output of the EUT.....	11
4.2.2 Arrangements for test signals at the input of transmitters.....	12
4.2.3 Arrangements for test signals at the output of transmitters.....	12
4.2.4 Arrangements for test signals at the input of receivers .....	12
4.2.5 Arrangements for test signals at the output of receivers .....	13
4.2.6 Idle mode .....	13
4.3 Exclusion bands.....	13
4.3.1 Receiver and receivers of duplex transceivers exclusion band .....	13
4.3.2 Transmitter exclusion band.....	13
4.4 Narrow band responses of receivers and receivers of duplex transceivers.....	13
4.5 Normal test modulation .....	14
5 Performance assessment.....	14
5.1 General .....	14
5.2 Equipment which can provide a continuous communications link .....	14
5.2.1 Equipment with analogue speech circuits.....	14
5.2.2 Equipment without analogue speech circuits.....	14
5.3 Equipment which does not provide a continuous communications link.....	14
5.4 Ancillary equipment .....	14
5.5 Equipment classification .....	14
6 Performance criteria .....	15
6.1 General .....	15
6.2 Performance criteria for Continuous phenomena applied to Transmitters (CT) .....	15
6.3 Performance criteria for Transient phenomena applied to Transmitters (TT).....	15
6.4 Performance criteria for Continuous phenomena applied to Receivers (CR).....	16
6.5 Performance criteria for Transient phenomena applied to Receivers (TR) .....	16
6.6 Performance criteria for ancillary equipment tested on a stand alone basis .....	16
7 Applicability overview .....	16
7.1 Emission.....	16
7.1.1 General.....	16
7.1.2 Special conditions .....	16
7.2 Immunity .....	17
7.2.1 General.....	17
7.2.2 Special conditions .....	17

<b>Annex A (informative):</b>	<b>Examples of mobile and portable radio and ancillary equipment for digital cellular radio telecommunications systems within the scope of the present document.....</b>	<b>19</b>
A.1	Mobile and portable radio equipment, and ancillary equipment meeting Phase 1, Phase 2, and Phase 2+ requirements of GSM 450 MHz, 900 MHz or DCS 1 800 MHz digital cellular telecommunications system.....	19
History	.....	20

---

# Intellectual Property Rights

IPRs essential or potentially essential to the present document may have been declared to ETSI. The information pertaining to these essential IPRs, if any, is publicly available for **ETSI members and non-members**, and can be found in ETSI SR 000 314: "*Intellectual Property Rights (IPRs); Essential, or potentially Essential, IPRs notified to ETSI in respect of ETSI standards*", which is available from the ETSI Secretariat. Latest updates are available on the ETSI Web server (<http://www.etsi.org/ipr>).

Pursuant to the ETSI IPR Policy, no investigation, including IPR searches, has been carried out by ETSI. No guarantee can be given as to the existence of other IPRs not referenced in ETSI SR 000 314 (or the updates on the ETSI Web server) which are, or may be, or may become, essential to the present document.

---

## Foreword

This Candidate Harmonized European Standard (Telecommunications series) has been produced by ETSI Technical Committee Electromagnetic compatibility and Radio spectrum Matters (ERM).

The present document has been produced by ETSI in response to a mandate from the European Commission issued under the Council Directive 98/34/EC [9] (as amended) laying down a procedure for the provision of information in the field of technical standards and regulation.

The present document, together with EN 301 489-1 [1], is intended to become a Harmonized EMC Standard, the reference of which will be published in the Official Journal of the European Communities referencing the Council Directive on the approximation of the laws of the Member States relating to electromagnetic compatibility (the "EMC Directive" 89/336/EEC [3] as amended), and the Council Directive on the approximation of the laws of the Member States relating to radio equipment and telecommunications terminal equipment and the mutual recognition of their conformity (the "R&TTE Directive" 1999/5/EC [2]).

The present document is part 7 of a multi-part EN covering the ElectroMagnetic Compatibility (EMC) standard for radio equipment and services, as identified below:

- Part 1: "Common technical requirements";
- Part 2: "Specific conditions for radio paging equipment";
- Part 3: "Specific conditions for Short-Range Devices (SRD) operating on frequencies between 9 kHz and 40 GHz";
- Part 4: "Specific conditions for fixed radio links and ancillary equipment and services";
- Part 5: "Specific conditions for Private land Mobile Radio (PMR) and ancillary equipment (speech and non-speech)";
- Part 6: "Specific conditions for Digital Enhanced Cordless Telecommunications (DECT) equipment";
- Part 7: "Specific conditions for mobile and portable radio and ancillary equipment of digital cellular radio telecommunications systems (GSM and DCS)";**
- Part 8: "Specific conditions for GSM base stations";
- Part 9: "Specific conditions for wireless microphones and similar Radio Frequency (RF) audio link equipment";
- Part 10: "Specific conditions for First (CT1 and CT1+) and Second Generation Cordless Telephone (CT2) equipment";
- Part 11: "Specific conditions for FM broadcasting transmitters";
- Part 12: "Specific conditions for Earth Stations operated in the frequency ranges between 4 GHz and 30 GHz in the Fixed Satellite Service (FSS)";
- Part 13: "Specific conditions for Citizens' Band (CB) radio and ancillary equipment (speech and non-speech)";
- Part 15: "Specific conditions for commercially available amateur radio equipment";

- Part 16: "Specific conditions for analogue cellular radio communications equipment, mobile and portable";
- Part 17: "Specific conditions for Wideband data and HIPERLAN equipment";
- Part 18: "Specific conditions for Terrestrial Trunked Radio (TETRA) equipment";
- Part 19: "Specific conditions for Receive Only Mobile Earth Stations (ROMES) operating in the 1,5 GHz band providing data communications";
- Part 20: "Specific conditions for Mobile Earth Stations (MES) used in the Mobile Satellite Services (MSS)";
- Part 22: "Specific conditions for ground based VHF aeronautical mobile and fixed radio equipment".

<b>National transposition dates</b>	
Date of adoption of this EN:	22 September 2000
Date of latest announcement of this EN (doa):	31 December 2000
Date of latest publication of new National Standard or endorsement of this EN (dop/e):	30 June 2001
Date of withdrawal of any conflicting National Standard (dow):	31 December 2003

---

# 1 Scope

The present document, together with EN 301 489-1 [1], covers the assessment of radio equipment meeting Phase 1, Phase 2, and Phase 2+ GSM and DCS digital cellular mobile and portable radio equipment transmitting and receiving speech and/or data, and operating in digital cellular radio telecommunications systems, and associated ancillary equipment in respect of ElectroMagnetic Compatibility (EMC).

Technical specifications related to the antenna port and emissions from the enclosure port of radio equipment are not included in the present document. Such technical specifications are found in the relevant product standards for the effective use of the radio spectrum.

The present document specifies the applicable test conditions, performance assessment and performance criteria for Phase 1, Phase 2, and Phase 2+ GSM and DCS digital cellular mobile and portable radio equipment, transmitting and receiving speech and/or data, and associated ancillary equipment.

Examples of digital cellular mobile and portable radio equipment covered by the present document are given in annex A.

In case of differences (for instance concerning special conditions, definitions, abbreviations) between the present document and EN 301 489-1 [1], the provisions of the present document take precedence.

Base station equipment (BTS and BSS) operating within network infrastructure is outside the scope of the present document. However, the present document does cover mobile and portable equipment that is intended to be operated in a fixed location while connected to the AC mains (see clause 5.5).

The environment classification and the emission and immunity requirements used in the present document are as stated in EN 301 489-1 [1], except for any special conditions included in the present document.

---

# 2 References

The following documents contain provisions which, through reference in this text, constitute provisions of the present document.

- References are either specific (identified by date of publication, edition number, version number, etc.) or non-specific.
- For a specific reference, subsequent revisions do not apply.
- For a non-specific reference, the latest version applies.

- [1] ETSI EN 301 489-1: "Electromagnetic compatibility and Radio spectrum Matters (ERM); ElectroMagnetic Compatibility (EMC) standard for radio equipment and services; Part 1: Common technical requirements".
- [2] Directive 1999/5/EC of the European Parliament and of the Council of 9 March 1999 on radio equipment and telecommunications equipment and the mutual recognition of their conformity.
- [3] Council Directive 89/336/EEC of 3 May 1989 on the approximation of the laws of the Member States relating to electromagnetic compatibility.
- [4] ETSI I-ETS 300 034-1: "European digital cellular telecommunications system (Phase 1); Radio subsystem link control (GSM 05.08)".
- [5] ETSI I-ETS 300 034-2: "European digital cellular telecommunications system (Phase 1); Radio subsystem link control; Part 2: DCS extension (GSM 05.08-DCS)".
- [6] ETSI ETS 300 578: "Digital cellular telecommunications system (Phase 2); Radio subsystem link control (GSM 05.08 version 4.22.1)".
- [7] ETSI TS 100 911: "Digital cellular telecommunications system (Phase 2+); Radio subsystem link control (GSM 05.08 version 6.2.0 Release 1997)".

- [8] ITU-T Recommendation P.64: "Telephone transmission quality, Telephone installations, Local line networks, Objective electro-acoustical measurements. Determination of sensitivity/frequency characteristics of local telephone systems".
- [9] Directive 98/34/EC of the European Parliament and of the Council of 22 June 1998 laying down a procedure for the provision of information in the field of technical standards and regulations.
- [10] ITU-T Recommendation P.76: "Determination of loudness ratings; fundamental principles".

---

## 3 Definitions and abbreviations

### 3.1 Definitions

For the purposes of the present document, the terms and definitions of EN 301 489-1 [1], clause 3 and the following apply.

**idle mode:** mode of operation of a receiver or a transceiver, where the Equipment Under Test (EUT) is powered, available for service and available to respond to a request to set up a call.

**RXQUAL:** measure of the received signal quality, which is generated by the mobile or portable equipment, for use as a criterion in the Radio Frequency (RF) power control and handover processes. For more information see:

- I-ETS 300 034-1 [4] clause 8.2 for Phase 1 GSM 900 equipment;
- I-ETS 300 034-2 [5] clause 8.2 for Phase 1 DCS 1800 equipment; or
- ETS 300 578 [6] clause 8.2 for Phase 2 GSM 900 or Phase 2 DCS 1800 equipment;
- TS 100 911 [7] clause 8.2 for Phase 2+ GSM 900 or Phase 2+ DCS 1800 equipment.

### 3.2 Abbreviations

For the purposes of the present document, the following abbreviations apply:

AC	Alternating Current
ARFCN	Absolute Radio Frequency Channel Number (see note)
BCCH	Broadcast Control Channel (see note)
BS	Base Station
BSS	Base Station System
BTS	Base Transceiver Station
CCCH	Common Control Channel (see note)
CR	Continuous phenomena applied to Receivers (clause 6.4)
CT	Continuous phenomena applied to Transmitters (clause 6.2)
DC	Direct Current
DTX	Discontinuous Transmission (see note)
EMC	Electromagnetic Compatibility
EUT	Equipment Under Test
LISN	Line Impedance Stabilizing Network
MRP	Mouth Reference Point (artificial head)
RF	Radio Frequency
rms	root mean square
RXQUAL	Receiver Quality (see note)
SPL	Sound Pressure Level
TR	Transient phenomena applied to Receivers (clause 6.5)
TT	Transient phenomena applied to Transmitters (clause 6.3)

NOTE: Refer to (GSM) functional radio standards for further details.



---

## 4 Test conditions

For the purpose of the present document, the test conditions of EN 301 489-1 [1], clause 4, shall apply as appropriate. Further product related test conditions for digital cellular mobile and portable radio equipment are specified in the present document.

### 4.1 General

For emission and immunity tests the test modulation, test arrangements, etc., as specified in the present document, clauses 4.1 to 4.5, shall apply.

Whenever the Equipment Under Test (EUT) is provided with a detachable antenna, the EUT shall be tested with the antenna fitted in a manner typical of normal intended use, unless specified otherwise.

### 4.2 Arrangements for test signals

The provisions of EN 301 489-1 [1], clause 4.2 shall apply.

#### 4.2.1 Arrangements for establishing a communications link

The nominal frequency of the wanted RF input signal (for the receivers) shall be selected by setting the Absolute Radio Frequency Channel Number (ARFCN) to an appropriate number (e.g. in case of GSM 900 MHz this is 60 to 65, and in case of GSM 1 800 MHz this is 690 to 706).

A communication link shall be set up with a suitable base station simulator (hereafter called "the test system").

When the EUT is required to be in the transmit/receive mode, the following conditions shall be met:

- the EUT shall be commanded to operate at maximum transmit power;
- the downlink RXQUAL shall be monitored.

##### 4.2.1.1 Calibration of the overall audio link performance

Prior to the test sequence, the reference level of the speech output signal on both the downlink and uplink shall be recorded on the test instrumentation, as shown in figure 1.

If the equipment does not include acoustical transducers (e.g. a microphone or loudspeaker) the equivalent electrical reference levels shall be specified by the manufacturer.

The voice processor may often apply noise and echo cancellation algorithms which attempt to eliminate or reduce steady state audio signals as e.g. the 1 kHz calibration signals.

The calibration shall be carried out with the noise and echo cancellation algorithms disabled. (Specific test software may be required).

If the noise and echo cancellation algorithms can not be disabled then the reference level of the speech output signal shall be measured using a max-hold detection on the audio level meter in order to determine the level before the noise and echo cancellation algorithms become effective.

#### Calibration of the downlink:

The EUT is not used for the calibration of the downlink. Adjust the output of the audio test source to achieve a reference level equivalent to a SPL of 0 dBPa at 1 kHz at the input of the acoustic coupler (tube in figure 1) for the downlink. Record the reading of the audio level meter as the reference level.

If in handsfree applications an external loudspeaker is used, the SPL from the external loudspeaker is higher than that from the ear piece of the portable by a certain amount in order overcome a high ambient noise level. Two methods can be used to achieve the required SPL:

- the downlink reference level shall be increased by the same amount in order to compensate for the difference in SPL, or
- the distance between the loudspeaker and the measuring microphone shall be adjusted during the measurement procedure resulting in the required SPL.

It is important that the dynamic range of the test instrumentation is not exceeded.

#### Calibration of the uplink:

For the calibration of the uplink the EUT is used. Adjust the output of the audio test source to achieve a reference level equivalent to a SPL of -5 dBPa at 1 kHz at the Mouth Reference Point (MRP) defined in ITU-T Recommendation P.64 [8]. Record the reading of the audio level meter, which is connected to the output of the test system, as the reference level.

For handsfree applications, normally no corrections are made to the uplink reference level. If it is not possible to perform the above calibration (e.g., a PC card with headset) the manufacturer shall specify the distance between the MRP and the microphone.

It is important that the dynamic range of the test instrumentation is not exceeded.

NOTE: The MRP is defined with respect to an artificial head defined in ITU-T Recommendation P.64 [8]) The handset shall be mounted on the artificial head such that the ear piece is centred at the artificial ear.

Both recorded levels (downlink and uplink) are used as reference levels for the performance assessment (see clauses 6.2 and 6.4).

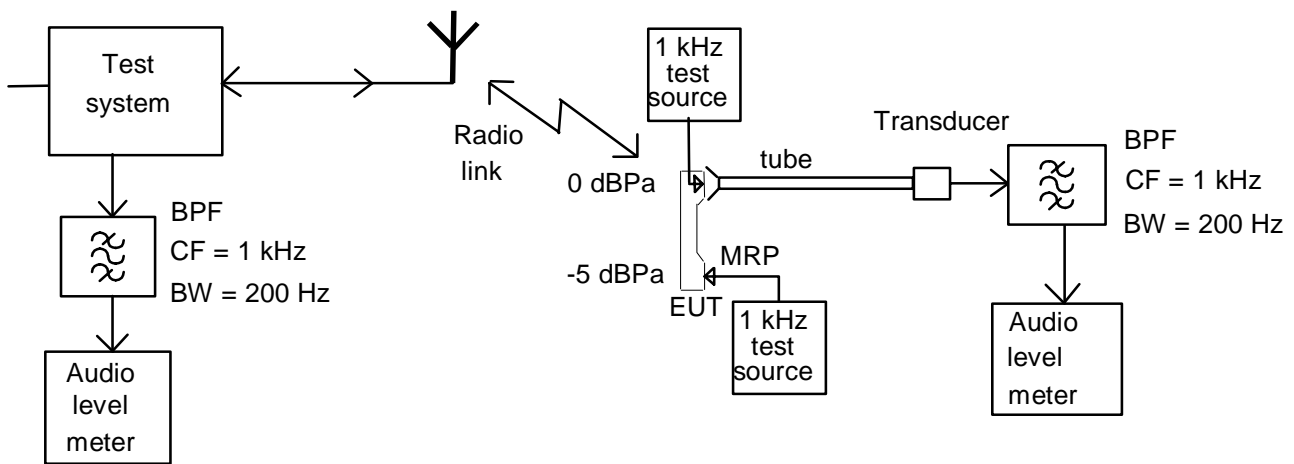

MRP = Mouth Reference Point

NOTE: The EUT is in position during calibration of the uplink, but not during calibration of the downlink where the EUT is replaced by the 1 kHz test audio source. During calibration of the uplink the mouthpiece shall be placed with respect to the MRP in a way representing intended use.

**Figure 1: Audio breakthrough measurement, calibration set-up for portable equipment**

#### 4.2.1.2 Measurement of the audio level at the speech output of the EUT

The voice processor may apply noise and echo cancellation algorithms which attempt to eliminate or reduce steady state audio signals as e.g. the 1 kHz calibration signals.

When the audio levels are measured during testing the EUT software shall be configured for voice applications. If the algorithms for noise and echo cancellation are not disabled, then the level shall be measured using a max-hold detection on the audio level meter in order to determine the level before the noise and echo cancellation algorithms become effective.

Set the EUT volume to provide the nominal audio level if specified by the manufacturer. If no such level is specified, the centre volume step shall be used. The volume settings shall be recorded in the test report.

The level of the output signal from the downlink speech channel of the EUT at the mobile or portable's ear piece shall be assessed by measuring the Sound Pressure Level (SPL) as shown in figure 2. When an external loudspeaker is used the acoustic coupler shall be fixed to the loudspeaker in the position used during the calibration.

The level of the decoded output signal from the uplink speech channel of the EUT at the analogue output of the test system shall be measured. Pick up of extraneous background noise by the microphone of the EUT shall be minimized, by sealing the speech input port (microphone) of the EUT (see figure 2).

If the equipment is designed for use with external transducers, they shall be included in the test configuration. If the equipment does not include acoustical transducers the line voltage developed across a specified termination impedance may be measured.

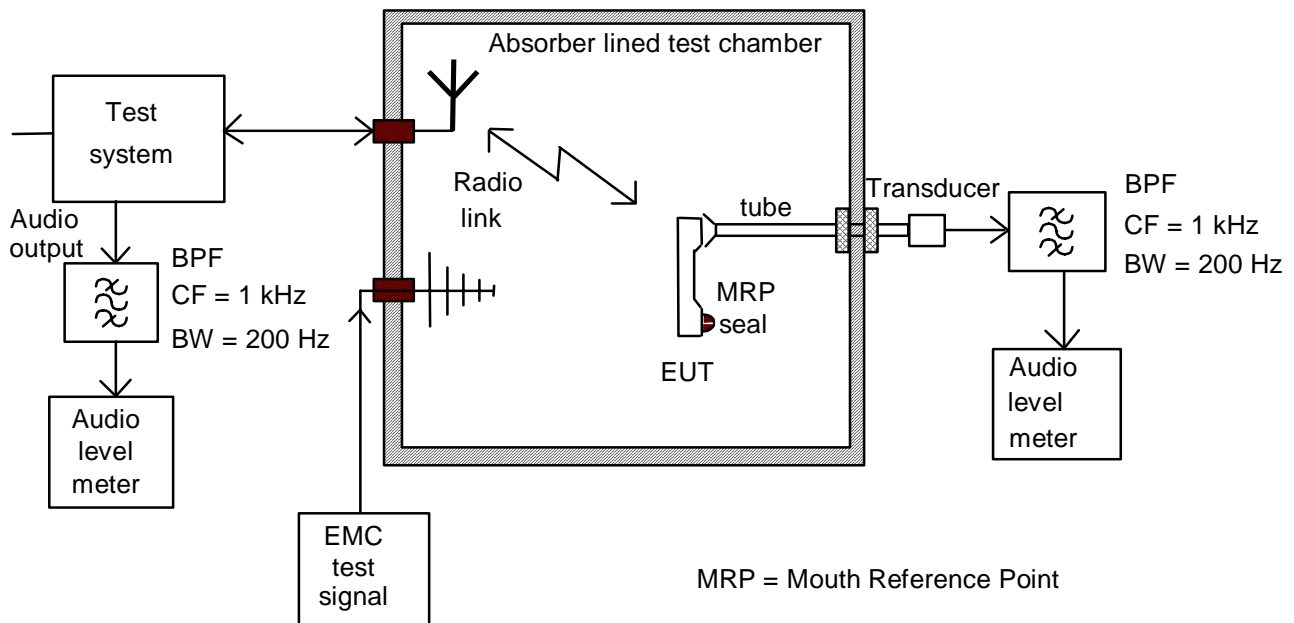

**Figure 2: Audio breakthrough measurement, test set-up for portable equipment**

#### 4.2.2 Arrangements for test signals at the input of transmitters

The provisions of EN 301 489-1 [1], clause 4.2.1 shall apply with the following modifications.

The test system shall command the EUT to disable Discontinuous Transmission (DTX).

A communication link shall be set up between the EUT and the test system.

#### 4.2.3 Arrangements for test signals at the output of transmitters

The provisions of EN 301 489-1 [1], clause 4.2.2 shall apply with the following modifications.

Where the equipment incorporates an external  $50\ \Omega$  RF antenna connector that is normally connected via a coaxial cable, then the wanted signal to establish a communication link shall be delivered from that connector by a coaxial cable.

Where the equipment incorporates an external  $50\ \Omega$  RF antenna connector, but this port is not normally connected via a coaxial cable, and where the equipment does not incorporate an external  $50\ \Omega$  RF connector (integral antenna equipment), then the wanted signal, to establish a communication link, shall be delivered from the equipment to an antenna located within the test environment.

#### 4.2.4 Arrangements for test signals at the input of receivers

The provisions of EN 301 489-1 [1], clause 4.2.3 shall apply with the following modifications.

Where the equipment incorporates an external  $50\ \Omega$  RF antenna connector that is normally connected via a coaxial cable, then the wanted signal to establish a communication link shall be delivered to that connector by a coaxial cable.

Where the equipment incorporates an external  $50\ \Omega$  RF antenna connector, but this port is not normally connected via a coaxial cable, and where the equipment does not incorporate an external  $50\ \Omega$  RF connector (integral antenna equipment), then the wanted signal, to establish a communication link, shall be presented to the equipment from an antenna located within the test environment.

The wanted RF input signal level shall be set to 40 dB above the reference sensitivity level as defined in TS 100 911 [7] clause 6.2 to provide a stable communication link.

## 4.2.5 Arrangements for test signals at the output of receivers

The provisions of EN 301 489-1 [1], clause 4.2.4 shall apply.

## 4.2.6 Idle mode

When the EUT is required to be in the idle mode, the test system shall simulate a Base Station (BS) with Broadcast Control Channel/Common Control Channel (BCCH/CCCH) on one carrier. The EUT shall be synchronized to the BCCH, listening to the CCCH and able to respond to paging messages. Periodic Location Updating shall be disabled.

## 4.3 Exclusion bands

The provisions of EN 301 489-1 [1], clause 4.3 shall apply.

### 4.3.1 Receiver and receivers of duplex transceivers exclusion band

The exclusion band for receivers and receiver sections of transceivers is the band of frequencies over which no immunity tests with radiated RF are made.

The lower frequency of the exclusion band is the lower frequency of the receive band of the EUT minus 6 % of that frequency.

The upper frequency of the exclusion band is the upper frequency of the receive band of the EUT plus 5 % of that frequency.

### 4.3.2 Transmitter exclusion band

The exclusion band for transmitters and transmitter sections of transceivers is the band of frequencies over which no immunity tests with radiated RF are made.

The exclusion band for transmitters extends three times the channel separation ( $3 \times 200 \text{ kHz} = 600 \text{ kHz}$ ) centred on the nominal operating frequency of the transmitter.

## 4.4 Narrow band responses of receivers and receivers of duplex transceivers

Responses on receivers or duplex transceivers occurring during the test at discrete frequencies which are narrow band responses (spurious responses), are identified by the following method (the procedure below only applies if the separation between test frequencies exceeds 500 kHz):

- if during an immunity test the RXQUAL or speech output signal level being monitored goes outside the specified figure, it is necessary to establish whether the RXQUAL increase or speech output signal level increase is due to a narrow band response or to a wide band phenomenon. Therefore, the test shall be repeated with the unwanted signal frequency increased, and then decreased by 400 kHz;
- if the RXQUAL increase or speech output signal level increase disappears in either or both of the above 400 kHz offset cases, then the response is considered as a narrow band response;
- if the RXQUAL increase or speech output signal level increase does not disappear, this may be due to the fact that the offset has made the frequency of the unwanted signal correspond to the frequency of another narrow band response. Under these circumstances the procedure is repeated with the increase and decrease of the frequency of the unwanted signal set to 500 kHz;
- if the RXQUAL increase or speech output signal level increase still does not disappear with the increased and/or decreased frequency, the phenomena is considered wide band and therefore an EMC problem and the equipment fails the test.

Narrow band responses are disregarded.

## 4.5 Normal test modulation

The immunity tests in voice call mode shall be performed without the application of any external modulation input signal.

For immunity tests in voice call mode, the overall audio uplink and downlink performance of the radio equipment shall be calibrated before the start of the tests. The calibration procedure is explained in clause 4.2.1.1.

The immunity tests in data mode shall be performed with the application of an appropriate external modulation input signal such that the performance of the data call can be monitored.

---

# 5 Performance assessment

## 5.1 General

The provision of EN 301 489-1 [1], clause 5.1 shall apply with the following modification.

The information about the bandwidth of the IF filter immediately preceding the demodulator as set out in EN 301 489-1 [1], clause 5.1 is not applicable to radio equipment in the scope of the present document.

## 5.2 Equipment which can provide a continuous communications link

The provision of EN 301 489-1 [1], clause 5.2 shall apply.

### 5.2.1 Equipment with analogue speech circuits

The performance of equipment which supports voice and data calls is assessed based on the voice call.

### 5.2.2 Equipment without analogue speech circuits

The assessment of the equipment performance shall be specified by the manufacturer.

## 5.3 Equipment which does not provide a continuous communications link

The provision of EN 301 489-1 [1], clause 5.3 shall apply.

## 5.4 Ancillary equipment

The provision of EN 301 489-1 [1], clause 5.4 shall apply with the following modification.

For emission measurements on transmitters performed in conjunction with associated ancillary equipment, the radiated emissions (spurious and wanted components) from the transmitter shall be ignored.

## 5.5 Equipment classification

The provision of EN 301 489-1 [1], clause 5.5 shall apply with the following modification.

Portable or mobile equipment or combinations of equipment, when used in conjunction with a charger powered from the AC mains, shall in addition fulfil the requirements of radio and ancillary equipment for fixed use (see tables 2 and 3 in clauses 7.1 and 7.2 of EN 301 489-1 [1]).

---

## 6 Performance criteria

### 6.1 General

The equipment shall meet the performance criteria specified in this clause and clauses 6.2, 6.3, 6.4 and 6.5, as appropriate.

Portable equipment intended for use whilst powered by the main battery of a vehicle shall additionally fulfil the applicable requirements set out in EN 301 489-1 [1], clauses 7.1 and 7.2 for mobile equipment.

Portable or mobile equipment powered by the AC mains shall additionally fulfil the applicable requirements of EN 301 489-1 [1], clauses 7.1 and 7.2 for radio and ancillary equipment for fixed use.

The establishment and maintenance of a communications link, the assessment of RXQUAL, and the assessment of the audio breakthrough by monitoring the speech output signal level, are used as performance criteria to ensure that all primary functions of the transmitter and receiver are evaluated during the immunity tests. In addition, the test shall also be performed in idle mode to ensure the transmitter does not unintentionally operate.

The maintenance of a communications link shall be assessed using an indicator which may be part of the test system or the EUT.

If an equipment is of a specialized nature, such that the performance criteria described in the following clauses are not appropriate, then the manufacturer shall declare, for inclusion in the test report, his own specification for an acceptable level of performance or degradation of performance during and/or after the immunity tests. The performance specification shall be included in the product description and documentation.

The performance criteria specified by the manufacturer shall give the same degree of immunity protection as called for in the following clauses.

### 6.2 Performance criteria for Continuous phenomena applied to Transmitters (CT)

A communication link shall be established at the start of the test, and maintained during the test, see clauses 4.2.2, 4.2.3, 4.2.4, and 4.2.5.

During the test, the uplink speech output level shall be at least 35 dB less than the previously recorded reference levels, when measured through an audio band pass filter of width 200 Hz, centred on 1 kHz (audio breakthrough check).

NOTE: When there is a high level background noise present the filter bandwidth can be reduced down to a minimum of 40 Hz.

At the conclusion of the test, the EUT shall operate as intended with no loss of user control functions or stored data, and the communication link shall have been maintained. In addition to confirming the above performance during a call, the test shall also be performed in idle mode, and the transmitter shall not unintentionally operate.

### 6.3 Performance criteria for Transient phenomena applied to Transmitters (TT)

A communications link shall be established at the start of the test, see clauses 4.2.2, 4.2.3, 4.2.4 and 4.2.5.

At the conclusion of each exposure the EUT shall operate with no user noticeable loss of the communication link.

At the conclusion of the total test comprising the series of individual exposures, the EUT shall operate as intended with no loss of user control functions or stored data, as declared by the manufacturer, and the communication link shall have been maintained.

In addition to confirming the above performance during a call, the test shall also be performed in idle mode, and the transmitter shall not unintentionally operate.

## 6.4 Performance criteria for Continuous phenomena applied to Receivers (CR)

A communications link shall be established at the start of the test, clauses 4.2.1, 4.2.2, 4.2.3 and 4.2.4.

During the test, the RXQUAL of the downlink shall not exceed the value of three, measured during each individual exposure in the test sequence.

During the test, the downlink speech output level shall be at least 35 dB less than the previously recorded reference levels, when measured through an audio band pass filter of width 200 Hz, centred on 1 kHz (audio breakthrough check).

NOTE: When there is a high level background noise present the filter bandwidth can be reduced down to a minimum of 40 Hz.

At the conclusion of the test, the EUT shall operate as intended with no loss of user control functions or stored data, and the communication link shall have been maintained.

## 6.5 Performance criteria for Transient phenomena applied to Receivers (TR)

A communications link shall be established at the start of the test, clauses 4.2.1, 4.2.2, 4.2.3 and 4.2.4.

At the conclusion of each exposure the EUT shall operate with no user noticeable loss of the communication link.

At the conclusion of the total test comprising the series of individual exposures, the EUT shall operate as intended with no loss of user control functions or stored data, as declared by the manufacturer, and the communication link shall have been maintained.

## 6.6 Performance criteria for ancillary equipment tested on a stand alone basis

The provision of EN 301 489-1 [1], clause 6.4 shall apply.

---

# 7 Applicability overview

## 7.1 Emission

### 7.1.1 General

EN 301 489-1 [1], table 2 contains the applicability of EMC emission measurements to the relevant ports of radio and/or associated ancillary equipment.

### 7.1.2 Special conditions

The following special conditions set out in table 1, relate to the emission test methods used in the EN 301 489-1 [1], clause 8.



**Table 1: Special conditions for EMC emission measurements**

Reference to clauses in EN 301 489-1 [1]	Special product-related conditions, additional to or modifying the test conditions in EN 301 489-1 [1], clause 8
<b>8.1 Test configuration; Methods of measurement and limits for EMC emissions</b>	The equipment shall be tested under normal test conditions as specified in the (GSM and DCS) functional radio standards, see references in clause 2 of the present document.
<b>8.2 Enclosure of ancillary equipment measured on a stand alone basis</b>	At the manufacturer's discretion, ancillary equipment can also be measured in combination with the radio equipment under test. When the ancillary equipment is measured in combination with the radio equipment, radiated emissions from the transmitter/transceiver shall be ignored, but recorded in the test report.
<b>8.3.2 Test method; DC power input/output ports</b>	These measurements do not apply to the DC supply port of portable equipment used in a charger.

## 7.2 Immunity

### 7.2.1 General

EN 301 489-1 [1], table 3 contains the applicability of EMC immunity measurements to the relevant ports of radio and/or associated ancillary equipment.

### 7.2.2 Special conditions

The following special conditions set out in table 2, relate to the immunity test methods and performance criteria used in EN 301 489-1 [1], clause 9.

Table 2: Special conditions for EMC immunity tests

Reference to clauses in EN 301 489-1 [1]	Special product-related conditions, additional to or modifying the test conditions in EN 301 489-1 [1], clause 9
<b>9.1 Test configuration; Test methods and levels for immunity tests</b>	The equipment shall be tested under normal test conditions as specified in the (GSM and DCS) functional radio standards, see references in clause 2 of the present document. - the equipment shall be tested in the most susceptible mode of operation; - the equipment shall fulfil the requirements in all modes of operation on its designated operation frequency bands. The transmitter part of the EUT shall be operated at its maximum rated output power.
<b>9.2.2 Test method; Radio frequency electromagnetic field (80 MHz - 1 000 MHz)</b>	When using the max hold detector method, initially at each test frequency step an unmodulated immunity test signal shall be applied. Then the modulation of the immunity RF test signal (1 kHz tone) shall be applied as specified in the EN 301 489-1 [1]. The test shall be repeated with the equipment in the idle mode of operation and the exclusion band shall not be used during this test.
<b>9.5 Radio frequency, common mode</b>	When using the max hold detector method, initially at each test frequency step an unmodulated immunity test signal shall be applied. Then the modulation of the immunity RF test signal (1 kHz tone) shall be applied as specified in the EN 301 489-1 [1].
<b>9.5.2 Test method; Radio frequency, common mode</b>	The test should be performed using the intrusive or direct connection method, if an intrusive or direct connection to any of the lines of any input/output port would affect the operation of the port, the current clamp injection method shall be used instead. The stepped frequency increments shall be 50 kHz or 1 % frequency increment of the momentary frequency in the frequency range 150 kHz to 5 MHz and 1 % frequency increment of the momentary frequency in the frequency range 5 MHz to 80 MHz. The test shall be repeated with the equipment in the idle mode of operation and the exclusion band shall not be used during this test.
<b>9.6.2.1 Test method; Transients and surges in the vehicular environment, Test requirements for 12 V DC powered equipment</b>	Mobile radio and ancillary equipment in the scope of the present document are not subject to immunity tests with Pulse 7. For radio equipment designed to operate at 12 V DC and 24 V DC supplies it is sufficient to apply pulse 4 for 12V DC systems and perform the 24 V DC tests set out in clause 9.6.2.2 of EN 301 489-1 [1].
<b>9.6.3 Performance criteria; Transients and surges in the vehicular environment</b>	During tests with pulses 3a and 3b, the performance criteria TT shall apply, see clause 6.3.
<b>9.7.3 Performance criteria; Voltage dips and interruptions</b>	For a voltage dip corresponding to a reduction of the supply voltage of 30 % for 10 ms the performance criteria TT or CR specified in clauses 6.3 or 6.4 shall apply as appropriate.

---

## Annex A (informative): Examples of mobile and portable radio and ancillary equipment for digital cellular radio telecommunications systems within the scope of the present document

The present document covers types of mobile and/or portable digital cellular radio telecommunications equipment as set out below.

---

### A.1 Mobile and portable radio equipment, and ancillary equipment meeting Phase 1, Phase 2, and Phase 2+ requirements of GSM 450 MHz, 900 MHz or DCS 1 800 MHz digital cellular telecommunications system

The present document applies to Phase 1, Phase 2, and Phase 2+ GSM 900 MHz and DCS 1 800 MHz digital cellular mobile and portable radio equipment, transmitting and receiving speech and/or data, and the associated ancillary equipment. Definitions for mobile and portable radio and associated ancillary equipment within the scope of the present document are found in the following GSM functional radio standards:

- I-ETS 300 034-1 [4] for Phase 1 GSM 900 equipment;
- I-ETS 300 034-2 [5] for Phase 1 DCS 1800 equipment; or
- ETSI ETS 300 578 [6] for Phase 2 GSM 900 or Phase 2 DCS 1800 equipment;
- ETSI TS 100 911 [7] for Phase 2+ GSM 900 or Phase 2+ DCS 1800 equipment.

---

## History

<b>Document history</b>		
V1.1.1	May 2000	One-step Approval Procedure OAP 20000922: 2000-05-24 to 2000-09-22
V1.1.1	September 2000	Publication