

Draft **ETSI EN 301 489-6** V1.1.1 (2000-05)

Candidate Harmonized European Standard (Telecommunications series)

**ElectroMagnetic compatibility
and Radio spectrum Matters (ERM);
ElectroMagnetic Compatibility (EMC) standard
for radio equipment and services;
Part 6: Specific conditions for Digital Enhanced Cordless
Telecommunications (DECT) equipment**



Reference

DEN/ERM-EMC-219-6

Keywords

DECT, EMC, radio, regulation

ETSI

650 Route des Lucioles
F-06921 Sophia Antipolis Cedex - FRANCE

Tel.: +33 4 92 94 42 00 Fax: +33 4 93 65 47 16

Siret N° 348 623 562 00017 - NAF 742 C
Association à but non lucratif enregistrée à la
Sous-Préfecture de Grasse (06) N° 7803/88

Important notice

Individual copies of the present document can be downloaded from:

<http://www.etsi.org>

The present document may be made available in more than one electronic version or in print. In any case of existing or perceived difference in contents between such versions, the reference version is the Portable Document Format (PDF).

In case of dispute, the reference shall be the printing on ETSI printers of the PDF version kept on a specific network drive within ETSI Secretariat.

Users of the present document should be aware that the document may be subject to revision or change of status.

Information on the current status of this and other ETSI documents is available at <http://www.etsi.org/tb/status/>

If you find errors in the present document, send your comment to:

editor@etsi.fr

Copyright Notification

No part may be reproduced except as authorized by written permission.
The copyright and the foregoing restriction extend to reproduction in all media.

© European Telecommunications Standards Institute 2000.
All rights reserved.

Contents

Intellectual Property Rights	4
Foreword	4
1 Scope	6
2 References	6
3 Definitions and abbreviations	7
3.1 Definitions	7
3.2 Abbreviations	7
4 Test conditions	7
4.1 General	7
4.2 Arrangements for test signals	8
4.2.1 Arrangements for test signals at the input of transmitters	8
4.2.1.1 Speech equipment	8
4.2.1.2 Non-speech equipment	8
4.2.2 Arrangements for test signals at the output of transmitters	8
4.2.3 Arrangements for test signals at the input of receivers	8
4.2.4 Arrangements for test signals at the output of receivers	8
4.2.5 Arrangements for testing transmitter and receiver together (as a system).....	8
4.3 Exclusion bands.....	8
4.4 Narrow band responses on receivers or receivers which are part of transceivers.....	8
4.5 Normal test modulation	9
5 Performance assessment.....	9
5.1 General	9
5.2 Arrangements for the assessment of host dependant equipment and plug-in cards	9
5.2.1 Alternative A: composite equipment.....	9
5.2.2 Alternative B: use of a test jig and three hosts	10
5.3 Assessment procedures.....	10
5.3.1 Loss of user control functions or stored user defined data.....	10
5.3.2 Audio breakthrough	10
5.4 Ancillary equipment	11
5.5 Equipment classification.....	11
6 Performance criteria	12
6.1 General	12
6.2 Performance criteria for Continuous phenomena of Transceivers (CT)	12
6.3 Performance criteria for Transient phenomena applied to Transceivers (TT).....	12
6.4 Performance criteria for Continuous phenomena applied to Receive-only equipment (CR)	13
6.5 Performance criteria for Transient phenomena applied to Receive-only equipment (TR)	13
6.6 Performance criteria for ancillary equipment tested on a stand alone basis	13
7 Applicability overview.....	13
7.1 Emission	13
7.1.1 General.....	13
7.1.2 Special conditions.....	13
7.2 Immunity	14
7.2.1 General.....	14
7.2.2 Special conditions.....	14
Annex A (normative): Definitions of cordless telecommunications equipment in the scope of the present document	15
A.1 Digital Enhanced Cordless Telecommunications (DECT) equipment	15
History	16

Intellectual Property Rights

IPRs essential or potentially essential to the present document may have been declared to ETSI. The information pertaining to these essential IPRs, if any, is publicly available for **ETSI members and non-members**, and can be found in SR 000 314: *"Intellectual Property Rights (IPRs); Essential, or potentially Essential, IPRs notified to ETSI in respect of ETSI standards"*, which is available from the ETSI Secretariat. Latest updates are available on the ETSI Web server (<http://www.etsi.org/ipr>).

Pursuant to the ETSI IPR Policy, no investigation, including IPR searches, has been carried out by ETSI. No guarantee can be given as to the existence of other IPRs not referenced in SR 000 314 (or the updates on the ETSI Web server) which are, or may be, or may become, essential to the present document.

Foreword

This Candidate Harmonized European Standard (Telecommunications series) has been produced by ETSI Technical Committee Electromagnetic compatibility and Radio spectrum Matters (ERM), and is now submitted for the ETSI standards One-step Approval Procedure.

The present document has been produced by ETSI in response to a mandate from the European Commission issued under the Council Directive 98/34/EC [8] (as amended) laying down a procedure for the provision of information in the field of technical standards and regulation.

The present document together, with EN 301 489-1 [1], is intended to become a Harmonized EMC Standard, the reference of which will be published in the Official Journal of the European Communities referencing the Council Directive on the approximation of the laws of the Member States relating to electromagnetic compatibility (the "EMC Directive" 89/336/EEC [3] as amended), and the Council Directive on the approximation of the laws of the Member States relating to radio equipment and telecommunications terminal equipment and the mutual recognition of their conformity (the "R&TTE Directive" 1999/5/EC [2]).

The present document is part 6 of a multi-part EN covering the ElectroMagnetic Compatibility and Radio Spectrum Matters (ERM); ElectroMagnetic Compatibility (EMC) standard for radio equipment and services, as identified below:

- Part 1: "Common technical requirements";
- Part 2: "Specific conditions for radio paging equipment";
- Part 3: "Specific conditions for Short-Range Devices (SRD) operating on frequencies between 9 kHz and 40 GHz";
- Part 4: "Specific conditions for fixed radio links and ancillary equipment and services";
- Part 5: "Specific conditions for Private land Mobile Radio (PMR) and ancillary equipment (speech and non-speech)";
- Part 6: "Specific conditions for Digital Enhanced Cordless Telecommunications (DECT) equipment";**
- Part 7: "Specific conditions for mobile and portable radio and ancillary equipment of digital cellular radio telecommunications systems (GSM and DCS)";
- Part 8: "Specific requirements for GSM base stations";
- Part 9: "Specific conditions for wireless microphones and similar Radio Frequency (RF) audio link equipment";
- Part 10: "Specific conditions for First (CT1 and CT1+) and Second Generation Cordless Telephone (CT2) equipment";
- Part 11: "Specific conditions for FM broadcasting transmitters";
- Part 12: "Specific conditions for Earth Stations operated in the frequency ranges between 4 GHz and 30 GHz in the Fixed Satellite Service (FSS)";

- Part 13: "Specific conditions for Citizens' Band (CB) radio and ancillary equipment (speech and non-speech)";
- Part 15: "Specific conditions for commercially available amateur radio equipment";
- Part 16: "Specific conditions for analogue cellular radio communications equipment, mobile and portable";
- Part 17: "Specific requirements for Wideband data and HIPERLAN";
- Part 18: "Specific requirements for Terrestrial Trunked Radio (TETRA)";
- Part 19: "Specific conditions for Receive Only Mobile Earth Stations (ROMES) operating in the 1,5 GHz band providing data communications";
- Part 20: "Specific conditions for Mobile Earth Stations (MES) used in the Mobile Satellite Services (MSS)";
- Part 21: "Specific requirements for LEO mobile Earth Stations".
- Part 22: "Specific requirements for VHF aeronautical mobile and fixed radios".

Proposed national transposition dates	
Date of latest announcement of this EN (doa):	3 months after ETSI publication
Date of latest publication of new National Standard or endorsement of this EN (dop/e):	6 months after doa
Date of withdrawal of any conflicting National Standard (dow):	36 months after doa

1 Scope

The present document, together with EN 301 489-1 [1], covers the assessment of Digital Enhanced Cordless Telecommunications (DECT) equipment, and associated ancillary equipment, in respect of ElectroMagnetic Compatibility (EMC).

Technical specifications related to the antenna port and emissions from the enclosure port of the radio equipment are not included in the present document. Such technical specifications are found in the relevant product standards for the effective use of the radio spectrum.

The present document specifies the applicable test conditions, performance assessment and performance criteria for Digital Enhanced Cordless Telecommunications (DECT) equipment, and associated ancillary equipment.

Definitions of types of cordless telecommunications equipment covered by the present document are given in annex A.

In case of differences (for instance concerning special conditions, definitions, abbreviations) between the present document and EN 301 489-1 [1], the provisions of the present document take precedence.

The environmental classification and the emission and immunity requirements used in the present document are as stated in EN 301 489-1 [1], except for any special conditions included in the present document.

2 References

The following documents contain provisions which, through reference in this text, constitute provisions of the present document.

- References are either specific (identified by date of publication, edition number, version number, etc.) or non-specific.
- For a specific reference, subsequent revisions do not apply.
- For a non-specific reference, the latest version applies.
- A non-specific reference to an ETS shall also be taken to refer to later versions published as an EN with the same number.

- [1] ETSI EN 301 489-1: "Electromagnetic compatibility and Radio spectrum Matters (ERM); ElectroMagnetic Compatibility (EMC) standard for radio equipment and services; Part 1: Common technical requirements".
- [2] Directive 1999/5/EC of the European Parliament and of the Council of 9 March 1999 on radio equipment and telecommunications equipment and the mutual recognition of their conformity.
- [3] Council Directive 89/336/EEC of 3 May 1989 on the approximation of the laws of the Member States relating to electromagnetic compatibility.
- [4] ITU-T Recommendation 0.153 (1988): "Basic parameters for the measurement of error performance at bit rates below the primary rate".
- [5] ETSI ETS 300 175-3: "Digital Enhanced Cordless Telecommunications (DECT); Common Interface (CI); Part 3: Medium Access Control (MAC) layer".
- [6] ETSI ETS 300 175-2: "Digital Enhanced Cordless Telecommunications (DECT); Common Interface (CI); Part 2: Physical Layer (PHL)".
- [7] ETSI I-ETS 300 176: "Digital Enhanced Cordless Telecommunications (DECT); Approval test specification".
- [8] Directive 98/34/EC of the European Parliament and of the Council of 22 June 1998 laying down a procedure for the provision of information in the field of technical standards and regulations.

3 Definitions and abbreviations

3.1 Definitions

For the purposes of the present document, the terms and definitions of EN 301 489-1 [1], clause 3 and the following apply as appropriate.

bearer: burst of the wanted RF signal used to establish and maintain the communications link for digital modulated and operated cordless telephone and similar radio communications equipment.

DECT equipment: Digital Enhanced Cordless Telecommunications apparatus which includes one or more transceivers and/or receivers and/or parts thereof which conform to the requirements of ETS 300 175-2 [6].

host equipment: any equipment which has a complete user functionality when not connected to the cordless telephone or similar radio communications equipment, and to which this radio equipment provides additional functionality, and to which connection is necessary for this radio equipment to offer functionality, and in which the transceiver part of the radio equipment is physically installed.

non-speech equipment: cordless telephone or similar communications equipment intended for the provision and reception of digital data either originating from or destined to external digital speech processing circuitry or other external equipment.

speech equipment: cordless telephone or similar communications equipment containing transducers such as microphones and/or loudspeakers intended for the provision and reception of acoustic audio signals.

3.2 Abbreviations

For the purposes of the present document, the following abbreviations apply:

BER	Bit Error Ratio
BPF	Band Pass Filter
BW	Band Width
CF	Carrier Frequency
CFP	Cordless Fixed Part
CPP	Cordless Portable Part
CR	Continuous phenomena applied to cordless telephone or communication Receive-only equipment
CT	Continuous phenomena applied to cordless telephone or communication Transceivers
CTA	Cordless Telephone Apparatus
DECT	Digital Enhanced Cordless Telecommunications
ERP	Ear Reference Point
FP	Fixed Part
MRP	Mouth Reference Point
PP	Portable Part
SPL	Sound Pressure Level
TR	Transient phenomena applied to cordless telephone or communication Receive-only equipment
TT	Transient phenomena applied to cordless telephone or communication Transceivers

4 Test conditions

4.1 General

For the purposes of the present document, the test conditions of EN 301 489-1 [1], clause 4, shall apply as appropriate. Further product related test conditions for cordless telephone or communication equipment are specified in the present document, subclauses 4.2 to 4.5.

4.2 Arrangements for test signals

The provisions of EN 301 489-1 [1], subclause 4.2 shall apply.

4.2.1 Arrangements for test signals at the input of transmitters

The provisions of EN 301 489-1 [1], subclause 4.2.1 shall apply with the following modification.

The transmitter part of the particular type of cordless telephone or communications equipment shall be modulated with normal test modulation as specified for that type of equipment (subclause 4.5).

4.2.1.1 Speech equipment

Audio input signals may be provided to the EUT either by a non-metallic acoustic tube or, if provided, electrical connections. The equipment shall not be modified to provide any electrical connection ports for the purposes of EMC tests only. Suitable test arrangements for the acoustic tube are described in I-ETS 300 176 [7].

4.2.1.2 Non-speech equipment

Digital (data) input signals shall be supplied to the EUT by electrical connection to the modulation input port via an appropriate connecting cable, test jig, or host equipment (subclauses 5.2.1 and 5.2.2).

4.2.2 Arrangements for test signals at the output of transmitters

The provisions of EN 301 489-1 [1], subclause 4.2.2 shall apply.

4.2.3 Arrangements for test signals at the input of receivers

The provisions of EN 301 489-1 [1], subclause 4.2.3 shall apply.

The receiver part or stand alone receiver of the particular type of cordless telephone or communications equipment shall be provided with the appropriate wanted RF signal modulated as specified for that type of equipment (subclause 4.5).

4.2.4 Arrangements for test signals at the output of receivers

The provisions of EN 301 489-1 [1], subclause 4.2.4 shall apply.

4.2.5 Arrangements for testing transmitter and receiver together (as a system)

The provisions of EN 301 489-1 [1], subclause 4.2.5 shall apply.

The normal test modulation shall be transmitted by the test system and looped back in the radio equipment, as described in ETS 300 175-3 [5] and I-ETS 300 176 [7]. Further, the output of the radio equipment under test shall be monitored by the test system.

4.3 Exclusion bands

No exclusion band applies to radio communications equipment intended for operation at designated frequencies above 1 GHz.

4.4 Narrow band responses on receivers or receivers which are part of transceivers

The provision of EN 301 489-1 [1], subclause 4.4 shall apply with the following modifications.

No immunity tests shall be carried out on frequencies of identified narrow band responses i.e. spurious responses, of the receiver parts of cordless telephone and similar communications equipment.

For DECT receivers, the identification criteria for narrow band responses are an increase of the speech output signal level for speech equipment, or an increase in the Bit Error Ratio (BER) of the looped back data from the EUT for non-speech equipment.

The nominal frequency offset to be used for the identification of narrowband responses shall be ± 2 MHz for the first part of the identification procedure, and $\pm 2,5$ MHz for its second part.

4.5 Normal test modulation

The provision of EN 301 489-1 [1], subclause 4.5 shall apply with the following modifications.

For all types of DECT equipment the wanted input signal shall be a Radio Frequency (RF) carrier set to the nominal centre frequency of one of the DECT RF channels, using Gaussian shaped frequency-shift keying (BT = 0,5) and modulated with a 1 152 kbit/s bit sequence.

The encoding of the bit sequence shall conform to the encoding specified in ETS 300 175-2 [6] and ETS 300 175-3 [5].

The parts of the data sequence that shall transmit a bit sequence conforming to the D-M2 pattern as specified in ITU-T Recommendation 0.153 [4] are those which are looped back according to the loop back test message described in ETS 300 175-3 [5].

The burst timings of this carrier shall conform to the limits specified in ETS 300 175-2 [6].

5 Performance assessment

5.1 General

The provision of EN 301 489-1 [1], subclause 5.1 shall apply.

5.2 Arrangements for the assessment of host dependant equipment and plug-in cards

For equipment parts for which integration with a host equipment is necessary in order to offer functionality, two alternative approaches defined in subclauses 5.2.1 and 5.2.2 may be used. The manufacturer shall declare which alternative shall be used.

5.2.1 Alternative A: composite equipment

A combination of the radio equipment part and a specific type of host equipment may be used for assessment according to the present document.

Where more than one such combination is intended, each combination shall be tested separately.

Where a specific combination of host equipment and a radio equipment part is tested as a composite system for compliance, repeat testing shall not be required for:

- those other combinations of hosts and radio equipment parts which are based on substantially similar host models in the circumstance that the variations in mechanical and electrical properties between such host models are unlikely to significantly influence the intrinsic immunity and unwanted emissions of the radio equipment part;
- the radio equipment part which cannot be used without mechanical, electrical, or software modification in variations of host equipment different from those represented by the units for which compliance to the present document has been demonstrated.

5.2.2 Alternative B: use of a test jig and three hosts

Where the radio equipment part is intended for use with a variety of host equipment, the manufacturer shall supply a suitable test jig to enable compliance with the present document to be assessed.

The test jig shall be designed such that alteration of the radio equipment part's intrinsic immunity and unwanted emissions is minimized.

Where connection between the radio equipment part and the host equipment control and/or power ports is by cables, optical fibres, or other similar means, this connection to the host shall be considered as a suitable test jig.

The test jig shall allow the radio equipment part to be powered and stimulated in a way representative of the way in which it would be powered and stimulated when connected to or inserted into the host equipment.

In addition to tests using the test jig the radio equipment part shall be tested in conjunction with three different host equipment. These hosts shall be provided by the manufacturer and shall be selected from the list of compatible hosts published by the manufacturer, as part of the user documentation supplied with the radio equipment part.

5.3 Assessment procedures

5.3.1 Loss of user control functions or stored user defined data

The test system shall set up a communications link in the same manner as the Equipment Under Test's (EUT) normal intended use.

Any user defined data fields in the memory or storage of the EUT shall be filled in a way representative of normal intended use.

The assessment procedure shall verify that the communications link is maintained and that there is no loss of user control functions declared by the manufacturer or loss of the stored user defined data.

5.3.2 Audio breakthrough

This test is used to assess the effect of continuous EMC phenomena on the analogue speech circuits of the equipment so fitted.

The test system shall be arranged as shown in figure 1 such that the level of the output signals from the EUT's speech channels can be recorded on suitable test instruments, though not necessarily in each channel simultaneously. For a Cordless Portable Part (CPP) with an acoustic transducer this will require the measurement of Sound Pressure Level (SPL). Pick-up of extraneous back-ground noise by the EUT's speech transducer (microphone) shall be minimized.

Prior to the test sequence, the reference level of the speech output signal shall be recorded on the test instrumentation as shown in figure 2. For a CPP with an acoustic speech transducer this shall be equivalent to 0 dBPa at 1 kHz, applied to the ear reference point in the receive path, and -5 dBPa at 1 kHz applied to the mouth reference point. For an Cordless Fixed Part (CFP) with analogue speech circuits and other implementations of the equipment with analogue speech circuits, the reference level shall be equivalent to these acoustic signals.

At each test frequency, the level of the acoustic output signal relative to the reference level shall be measured.

Where it is necessary to interface to the acoustic transducers of the EUT care shall be taken to ensure that the disturbance to the EM field is minimized. The use of a non metallic acoustic coupler as described in I-ETS 300 176 [7] is recommended.

The precise arrangements shall be recorded in the test report.

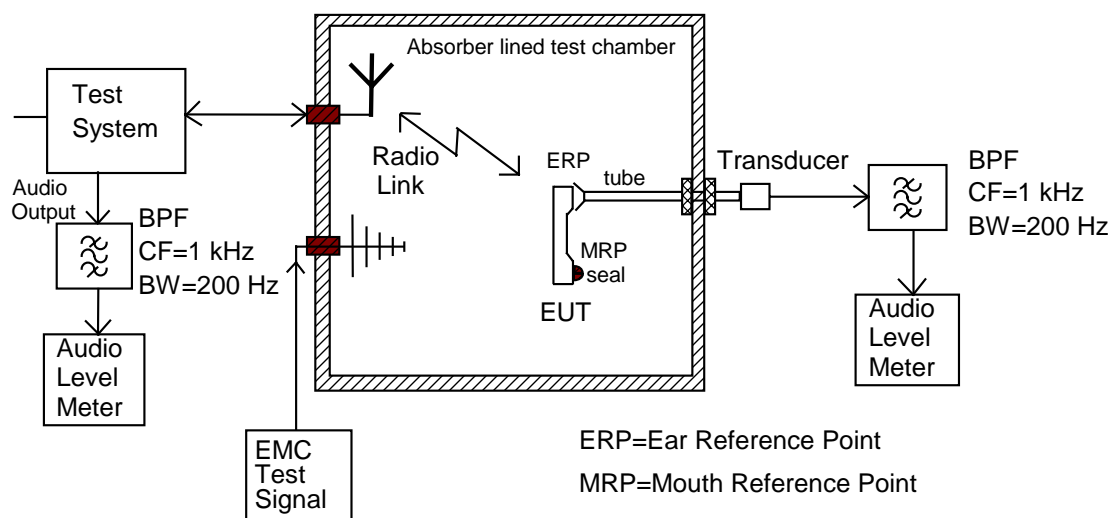
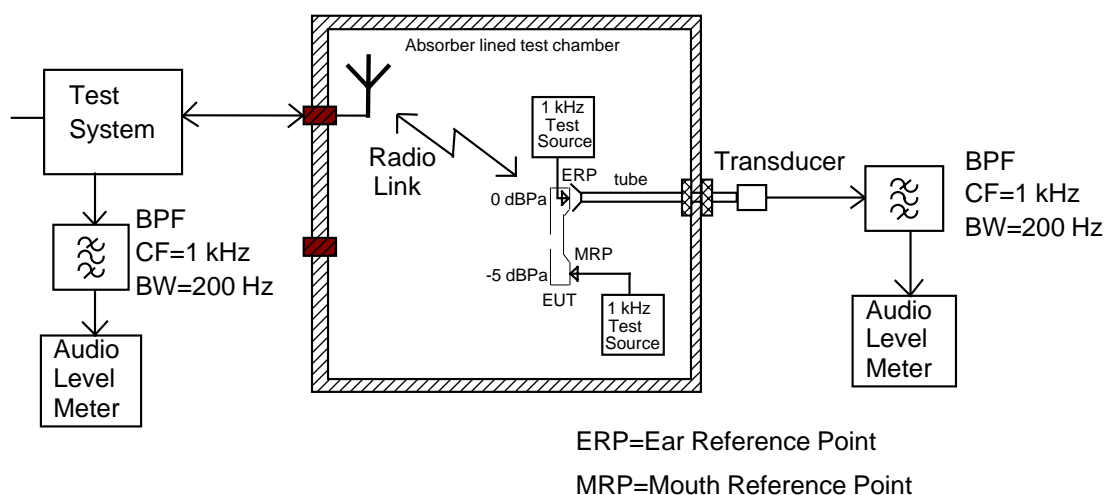

Figure 1: Audio breakthrough measurement, test set-up



NOTE: The EUT is in position during calibration of the uplink, but not during calibration of the downlink.

Figure 2: Audio breakthrough measurement, calibration set-up

5.4 Ancillary equipment

The provision of EN 301 489-1 [1], subclause 5.4 shall apply.

5.5 Equipment classification

The provision of EN 301 489-1 [1], subclause 5.5 shall apply with the following modifications:

- Cordless telephone and communications equipment and/or ancillary equipment or combinations thereof declared as capable of being powered for intended use by the main battery of a vehicle shall additionally be considered as mobile equipment;
- Cordless telephone and communications equipment and/or ancillary equipment or combinations thereof declared as capable of being powered for intended use by an AC mains network shall additionally be considered as base station equipment, although the input/output arrangements of the equipment and the performance criteria may remain as for the original class, as appropriate.

NOTE: The above information is necessary because both corresponding parts of cordless telephone and similar communications equipment - handset or plug-in card and base station - are usually intended for "fixed use" at a distinct location. When such corresponding parts of equipment also are intended for use e.g. in coaches or buses, then the EMC requirements for mobile equipment shall apply additionally. The same consideration belongs to plug-in cards requiring adequate host equipment powered by the AC mains. In this case the EMC requirements for base station equipment apply to the combination of the plug-in card and host as well.

6 Performance criteria

6.1 General

The manufacturer shall declare, also for recording in the test report, the primary functions to be checked during and after the conclusion of EMC tests.

The equipment shall meet the minimum performance criteria as specified in subclauses 6.2, 6.3, 6.4 and 6.5 and additionally the primary functions as declared by the manufacturer.

6.2 Performance criteria for Continuous phenomena of Transceivers (CT)

The establishment of a communications link at the start of the test, the maintenance of the communications link during and after the test, the assessment of BER, and in case of equipment containing analogue speech circuits, the assessment of the speech output signal level, are used as performance criteria to ensure that the primary functions of the transceiver or receiver are evaluated during and/or after the test.

During the immunity test,

- the test system shall control the EUT so that it transmits continuously on a specified slot and channel according to the test procedures described in ETS 300 175-3 [5], this way indicating that the communications link is maintained;
- the test system shall verify a Bit Error Ratio (BER) of 1×10^{-3} or better; and
- additionally, for equipment containing analogue speech circuits the speech output signal level shall be at least 35 dB less than the reference level recorded before the start of the test. This shall be verified by the procedure in subclause 5.3.2.

At the conclusion of the immunity test,

- the test system shall send the test message "clear test modes" as described in ETS 300 175-3 [5], this way indicating that the bearer and thus the communications link was maintained during the test sequence and that the EUT is still operational; and
- the EUT shall operate as intended with no loss of user control functions or stored data and the communications link shall have been maintained during and after the test (subclause 5.3.1).

Where the EUT is capable of transmission, tests shall be performed to ensure that unintentional transmission does not occur.

6.3 Performance criteria for Transient phenomena applied to Transceivers (TT)

At the conclusion of each individual exposure in a test sequence, the EUT shall continue to operate with no user noticeable loss of the communications link.

At the conclusion of the total test comprising the series of individual exposures the EUT shall continue to operate as intended with no loss of user control functions or stored data, as declared by the manufacturer, and the communications link shall have been maintained (subclause 5.3.1).

Where the EUT is capable of transmission, tests shall be performed to ensure that unintentional transmission does not occur.

6.4 Performance criteria for Continuous phenomena applied to Receive-only equipment (CR)

The primary functions shall be verified during each individual exposure in the test sequence.

Additionally, for equipment containing analogue speech circuits the speech output signal level shall be at least 35 dB less than the previously recorded reference level. This shall be verified by the procedure in subclause 5.3.2.

At the conclusion of the test, the EUT shall continue to operate as intended with no loss of user control functions or stored data, and the communications link shall have been maintained. This shall be verified by checking the primary functions.

6.5 Performance criteria for Transient phenomena applied to Receive-only equipment (TR)

At the conclusion of each exposure the EUT shall continue to operate with no user noticeable loss of the communications link.

At the conclusion of the total test comprising the series of individual exposures the EUT shall continue to operate as intended with no loss of user control functions or stored data, as declared by the manufacturer, and the communications link shall have been maintained. This shall be verified by checking the primary functions.

6.6 Performance criteria for ancillary equipment tested on a stand alone basis

The provision of EN 301 489-1 [1], subclause 6.4 shall apply.

7 Applicability overview

7.1 Emission

7.1.1 General

EN 301 489-1 [1], table 2, contains the applicability of EMC emission measurements to the relevant ports of radio and/or associated ancillary equipment.

7.1.2 Special conditions

No special conditions shall apply to radio equipment in the scope of the present document.

7.2 Immunity

7.2.1 General

EN 301 489-1 [1], table 3, contains the applicability of EMC immunity measurements to the relevant ports of radio and/or associated ancillary equipment.

7.2.2 Special conditions

No special conditions shall apply to radio equipment in the scope of the present document.

Annex A (normative): Definitions of cordless telecommunications equipment in the scope of the present document

The present document covers types of cordless telecommunications equipment as set out below.

A.1 Digital Enhanced Cordless Telecommunications (DECT) equipment

The present document applies to DECT equipment and associated ancillary equipment providing:

- wireless access to telephone subscriber lines and/or similar speech and data transmission purposes within private networks and/or the residential environment; or
- fixed wireless access to the PSTN.

DECT equipment may comprise of either handset transceivers and base transceivers as defined in ETS 300 175-3 [5], or radio base transceivers and subscriber radio terminal equipment for fixed wireless access.

History

Document history			
V1.1.1	May 2000	One-step Approval Procedure	OAP 20000922: 2000-05-24 to 2000-09-22