

ETSI EN 301 469-8 V1.1.1 (2000-10)

European Standard (Telecommunications series)

**Digital Enhanced Cordless Telecommunications (DECT);
DECT Packet Radio Service (DPRS) Test Case Library (TCL);
Part 8: Abstract Test Suite (ATS) -
Network (NWK) layer -
Portable radio Termination (PT)**



Reference

DEN/DECT-040047-8

Keywords

ATS, DECT, DPRS, network, data, testing

ETSI

650 Route des Lucioles
F-06921 Sophia Antipolis Cedex - FRANCE

Tel.: +33 4 92 94 42 00 Fax: +33 4 93 65 47 16

Siret N° 348 623 562 00017 - NAF 742 C
Association à but non lucratif enregistrée à la
Sous-Préfecture de Grasse (06) N° 7803/88

Important notice

Individual copies of the present document can be downloaded from:

<http://www.etsi.org>

The present document may be made available in more than one electronic version or in print. In any case of existing or perceived difference in contents between such versions, the reference version is the Portable Document Format (PDF). In case of dispute, the reference shall be the printing on ETSI printers of the PDF version kept on a specific network drive within ETSI Secretariat.

Users of the present document should be aware that the document may be subject to revision or change of status. Information on the current status of this and other ETSI documents is available at <http://www.etsi.org/tb/status/>

If you find errors in the present document, send your comment to:
editor@etsi.fr

Copyright Notification

No part may be reproduced except as authorized by written permission.
The copyright and the foregoing restriction extend to reproduction in all media.

© European Telecommunications Standards Institute 2000.
All rights reserved.

Contents

Intellectual Property Rights	5
Foreword.....	5
1 Scope	6
2 References	6
3 Definitions and abbreviations.....	7
3.1 Definitions	7
3.2 Abbreviations	7
4 Abstract Test Method (ATM).....	8
5 Untestable Test Purposes (TP)	9
6 ATS Conventions	9
6.1 Naming conventions.....	9
6.1.1 Declarations part.....	9
6.1.1.1 Test suite type and structured type definitions	9
6.1.1.2 Test suite operations definitions.....	10
6.1.1.3 Test suite parameter declarations	10
6.1.1.4 Test case selection expression definitions	10
6.1.1.5 Test suite constant declarations.....	10
6.1.1.6 Test suite variable declarations	10
6.1.1.7 Test case variable declarations	10
6.1.1.8 PCO declarations.....	11
6.1.1.9 Timer declarations.....	11
6.1.1.10 ASP type definitions	11
6.1.1.11 PDU type definitions.....	11
6.1.1.12 Alias definitions	11
6.1.2 Constraints part.....	12
6.1.3 Dynamic part	14
6.1.3.1 Test Case (TC) identifier.....	14
6.1.3.2 Test step identifier.....	14
6.1.3.3 Default identifier	14
6.1.3.4 Label identifier	15
6.1.3.5 ATS abbreviations.....	15
6.2 Implementation conventions	15
6.2.1 Declaration part	15
6.2.2 Constraint part	16
6.2.3 Dynamic part	16
Annex A (normative): Abstract Test Suite (ATS).....	17
A.1 The TTCN Graphical form (TTCN.GR)	17
A.2 The TTCN Machine Processable form (TTCN.MP).....	17
Annex B (normative): Partial PIXIT proforma for DPRS NWK PT.....	18
B.1 Identification summary.....	18
B.2 ATS summary	18
B.3 Test laboratory.....	18
B.4 Client identification.....	19
B.5 SUT	19
B.6 Protocol layer information.....	19
B.6.1 Protocol identification	19

B.6.2	IUT information	20
B.6.2.1	General configuration	20
Annex C (normative): Protocol Conformance Test Report (PCTR) Proforma for DPRS		
	NWK PT	25
C.1	Identification summary.....	25
C.1.1	Protocol conformance test report.....	25
C.1.2	IUT identification	25
C.1.3	Testing environment.....	25
C.1.4	Limits and reservation	26
C.1.5	Comments.....	26
C.2	IUT Conformance status	26
C.3	Static conformance summary	26
C.4	Dynamic conformance summary.....	26
C.5	Static conformance review report.....	27
C.6	Test campaign report.....	27
C.7	Observations.....	30
	Bibliography	31
	History	32

Intellectual Property Rights

IPRs essential or potentially essential to the present document may have been declared to ETSI. The information pertaining to these essential IPRs, if any, is publicly available for **ETSI members and non-members**, and can be found in ETSI SR 000 314: "*Intellectual Property Rights (IPRs); Essential, or potentially Essential, IPRs notified to ETSI in respect of ETSI standards*", which is available from the ETSI Secretariat. Latest updates are available on the ETSI Web server (<http://www.etsi.org/ipr>).

Pursuant to the ETSI IPR Policy, no investigation, including IPR searches, has been carried out by ETSI. No guarantee can be given as to the existence of other IPRs not referenced in ETSI SR 000 314 (or the updates on the ETSI Web server) which are, or may be, or may become, essential to the present document.

Foreword

This European Standard (Telecommunications series) has been produced by ETSI Project Digital Enhanced Cordless Telecommunications (DECT).

The present document is part 8 of a multi-part deliverable covering the Digital Enhanced Cordless Telecommunications (DECT); DECT Packet Radio Service (DPRS) Test Case Library (TCL), as identified below:

- Part 1: "Test Suite Structure (TSS) and Test Purposes (TP) - Medium Access Control (MAC) layer";
- Part 2: "Abstract Test Suite (ATS) - Medium Access Control (MAC) layer - Portable radio Termination (PT)";
- Part 3: "Abstract Test Suite (ATS) - Medium Access Control (MAC) layer - Fixed radio Termination (FT)";
- Part 4: "Test Suite Structure (TSS) and Test Purposes (TP) - Data Link Control (DLC) layer";
- Part 5: "Abstract Test Suite (ATS) - Data Link Control (DLC) layer - Portable radio Termination (PT)";
- Part 6: "Abstract Test Suite (ATS) - Data Link Control (DLC) layer - Fixed radio Termination (FT)";
- Part 7: "Test Suite Structure (TSS) and Test Purposes (TP) - Network (NWK) layer";
- Part 8: "Abstract Test Suite (ATS) - Network (NWK) layer - Portable radio Termination (PT)";**
- Part 9: "Abstract Test Suite (ATS) - Network (NWK) layer - Fixed radio Termination (FT)".

National transposition dates	
Date of adoption of this EN:	13 October 2000
Date of latest announcement of this EN (doa):	31 January 2001
Date of latest publication of new National Standard or endorsement of this EN (dop/e):	31 July 2001
Date of withdrawal of any conflicting National Standard (dow):	31 July 2001

1 Scope

The present document contains the Abstract Test Suite (ATS) specification to test the DECT Packet Radio Service (DPRS) Network (NWK) layer at the Portable radio Termination (PT).

The objective of this test specification is to provide a basis for conformance tests for DECT equipment giving a high probability of air interface inter-operability between different manufacturers' DECT equipment.

The ISO standard for the methodology of conformance testing (ISO/IEC 9646-1 [8] and ISO/IEC 9646-2 [9]) as well as the ETSI rules for conformance testing (ETS 300 406 [7]) are used as a basis for the test methodology.

Annex A provides the Tree and Tabular Combined Notation (TTCN) part of this ATS.

Annex B provides the Partial Protocol Implementation Extra Information for Testing (PIXIT) Proforma of this ATS.

Annex C provides the Protocol Conformance Test Report (PCTR) Proforma of this ATS.

2 References

The following documents contain provisions which, through reference in this text, constitute provisions of the present document.

- References are either specific (identified by date of publication, edition number, version number, etc.) or non-specific.
- For a specific reference, subsequent revisions do not apply.
- For a non-specific reference, the latest version applies.
- A non-specific reference to an ETS shall also be taken to refer to later versions published as an EN with the same number.

- [1] ETSI EN 300 175-1: "Digital Enhanced Cordless Telecommunications (DECT); Common Interface (CI); Part 1: Overview".
- [2] ETSI EN 300 175-4: "Digital Enhanced Cordless Telecommunications (DECT); Common Interface (CI); Part 4: Data Link Control (DLC) layer".
- [3] ETSI EN 300 175-5: "Digital Enhanced Cordless Telecommunications (DECT); Common Interface (CI); Part 5: Network (NWK) layer".
- [4] ETSI EN 300 175-6: "Digital Enhanced Cordless Telecommunications (DECT); Common Interface (CI); Part 6: Identities and addressing".
- [5] ETSI EN 300 175-7: "Digital Enhanced Cordless Telecommunications (DECT); Common Interface (CI); Part 7: Security features".
- [6] ETSI EN 301 649: "Digital Enhanced Cordless Telecommunications (DECT); DECT Packet Radio Services (DPRS)".
- [7] ETSI ETS 300 406: "Methods for Testing and Specification (MTS); Protocol and profile conformance testing specifications; Standardization methodology".
- [8] ISO/IEC 9646-1: "Information technology - Open Systems Interconnection - Conformance testing methodology and framework - Part 1: General concepts". (See also CCITT Recommendation X.290).
- [9] ISO/IEC 9646-2: "Information technology - Open Systems Interconnection - Conformance testing methodology and framework - Part 2: Abstract test suite specification". (See also CCITT Recommendation X.291).

- [10] ISO/IEC 9646-3: "Information technology - Open Systems Interconnection - Conformance testing methodology and framework - Part 3: The tree and tabular combined notation". (See also CCITT Recommendation X.292).
- [11] ISO/IEC 9646-6: "Information technology - Open Systems Interconnection - Conformance testing methodology and framework - Part 6: Protocol profile test specification".
- [12] ISO/IEC 9646-7: "Information technology - Open Systems Interconnection - Conformance testing methodology and framework - Part 7: Implementation conformance statement".
- [13] ETSI EN 300 444: "Digital Enhanced Cordless Telecommunications (DECT); Generic Access Profile (GAP)".

3 Definitions and abbreviations

3.1 Definitions

For the purposes of the present document, the following terms and definitions apply:

- a) the terms given in ISO/IEC 9646-1 [8], ISO/IEC 9646-2 [9]; and
- b) the definitions given in EN 300 175-1 [1], EN 300 175-5 [3], EN 300 175-6 [4] and EN 300 175-7 [5].

3.2 Abbreviations

For the purposes of the present document, the abbreviations given in ISO/IEC 9646-1 [8], ISO/IEC 9646-6 [11], ISO/IEC 9646-7 [12] and EN 300 175-5 [3] apply. In particular, the following abbreviations apply:

AC	Authentication Code
AR	Access Rights
ASP	Abstract Service Primitive
ATM	Abstract Test Method
ATS	Abstract Test Suite
AU	Authentication
BI	Invalid Behaviour
BO	Inopportune Behaviour
BV	Valid Behaviour
CA	Capability tests
CC	Call Control
CH	Ciphering
DLC	Data Link Control
FP	Fixed Part
FT	Fixed radio Termination
ID	Identification
IPEI	International Portable Equipment Identity
IPUI	International Portable User Identity
IUT	Implementation Under Test
KA	Key Allocation
LO	Location
LT	Lower Tester
MAC	Medium Access Control
MM	Mobility Management
NWK	Network
PARK	Portable Access Rights Key
PCO	Point of Control and Observation
PDU	Protocol Data Unit
PHL	Physical Layer
PICS	Protocol Implementation Conformance Statement
PIXIT	Protocol Implementation Extra Information for Testing

PP	Portable Part
PT	Portable radio Termination
REP	Radio End Point
RF	Radio Frequency
RFP	Radio Fixed Part
RPN	Radio Fixed Part Number
SAP	Service Access Point
SUT	System Under Test
TC	Test Case
TP	Test Purposes
TSS	Test Suite Structure
TTCN	Tree and Tabular Combined Notation
UT	Upper Tester

4 Abstract Test Method (ATM)

This clause describes the ATM, the Point of Control and Observation (PCO) used to test the NWK layer of the PT.

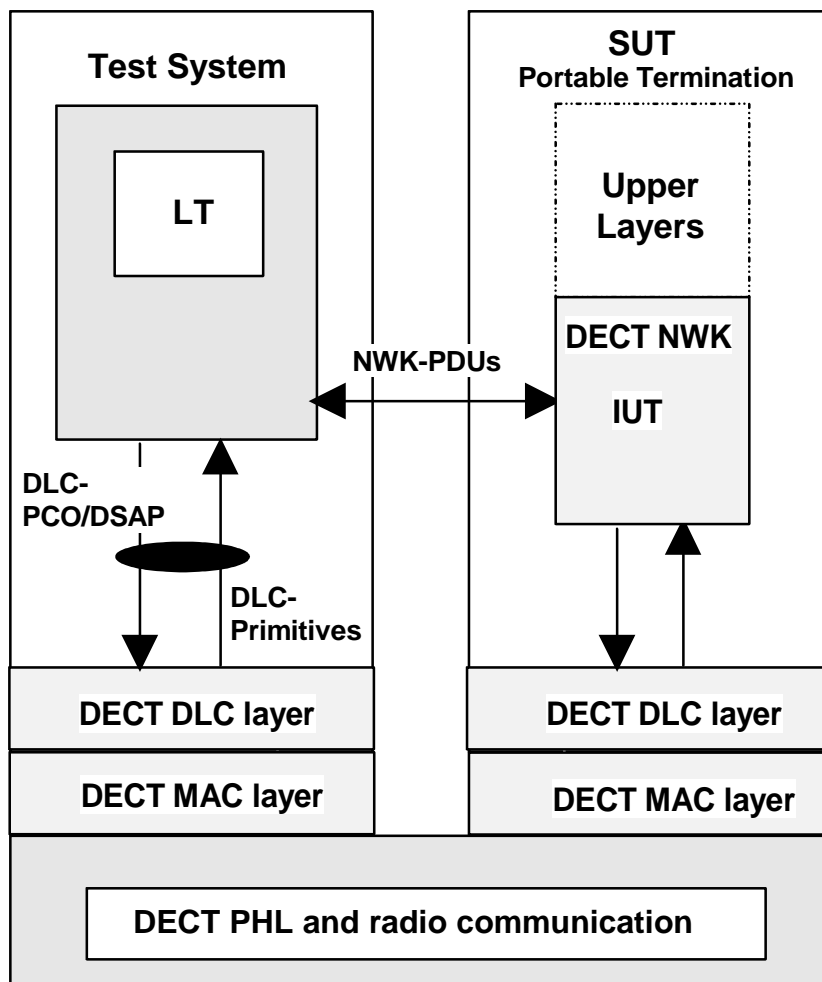

Figure 1: RS test Method embedded variant

- LT:** a lower tester (LT) is located in a remote DECT test system. It controls and observes the behaviour of the Implementation Under Test (IUT).
- DSAP:** a unique Data Link Control (DLC) SAP is defined at the DECT interface and used to exchange service data of the NWK protocol.
- PCO:** the PCO for Network Layer testing is located on the DSAP. All test events at the PCO are specified in terms of DLC Abstract Service Primitives (ASP) and NWK Protocol Data Units (PDUs).
- Notional UT** no explicit upper tester (UT) exists in the system under test. However, the System Under Test (SUT) needs to carry out some UL functions to achieve some effects of test co-ordination procedures. Designing ATS, the capability of the Interworking Unit (IWU), such as PSTN, ISDN or GSM IWU might be taken into account. An example of such controls could be to provoke restarting of the IUT through the Q interface.

The DLC primitives are defined according to EN 300 175-4 [2], subclauses 8.3.2 (S-SAP primitives) and 8.3.3 (B-SAP primitives).

5 Untestable Test Purposes (TP)

Due to the ATMs chosen for this ATS or other restrictions, the test purposes in table 1 have been identified as being in the untestable category, and therefore have not been derived into final test case:

Table 1: Untestable TP

Test purpose	Reason

6 ATS Conventions

This clause describes the conventions applied to define the ATS and gives the naming conventions chosen for the different elements of the ATS.

The ATS conventions are intended to give a better understanding of the ATS but they describe also the conventions made for the development of the ATS, thus for any later maintenance purposes or further development of the ATS the conventions described in this clause shall be considered.

The ATS conventions contain two subclauses, the naming conventions and the implementation conventions. The naming conventions describe the structure of the naming of all ATS elements. The implementation conventions describe the functional structure of the ATS.

To define the ATS, the guidelines of ETS 300 406 [7] were considered.

6.1 Naming conventions

6.1.1 Declarations part

This subclause describes the naming conventions chosen for the elements of the ATS declarations part.

6.1.1.1 Test suite type and structured type definitions

The test suite type and test suite structured type identifiers describe the information elements, and are written in uppercase:

EXAMPLE: PROTOCOL_DISCRIMINATOR simple type
 FILLSTRING structured type

6.1.1.2 Test suite operations definitions

The test suite operation identifiers are composed of substrings in lowercase letters, except for standard prefix "TSO_". Each substring is separated by an underscore character ("_").

EXAMPLE: TSO_compute_checksum.

6.1.1.3 Test suite parameter declarations

The test suite parameter identifiers are composed of substrings in lowercase letters, except for the standard prefix "TSP_". Each substring is separated by an underscore character ("_").

EXAMPLE 1: TSP_window_size.

If the test suite parameter references a Protocol Implementation Conformance Statement (PICS) item, the letter "C" is added to the standard prefix.

EXAMPLE 2: TSPC_pics_item_s23.

If the test suite parameter references a PIXIT item, the letter "X" is added to the standard prefix.

EXAMPLE 3: TSPX_pixit_item_2.

Exception: If the test suite parameter represents a system parameter or value, only the name defined in the specifications is used (e.g. V_S = send sequence variable).

Complete names as defined in the specifications are used.

6.1.1.4 Test case selection expression definitions

All selection expression names for test groups are to be preceded with the prefix "SENG_".

All selection expression names for test cases are to be preceded with the prefix "SENC_".

6.1.1.5 Test suite constant declarations

The test suite constant identifiers are composed of substrings in lowercase letters, except for the prefix "TSC_". Each substring is separated by an underscore character ("_").

EXAMPLE: TSC_retry.

Exception: If the TSC represents a system parameter or value, only the name defined in the specifications is used (e.g. N250).

Complete names as defined in the specifications are used.

6.1.1.6 Test suite variable declarations

The test suite variable identifiers are composed of substrings in lowercase letters, except for the prefix "TSV_". Each substring is separated by an underscore character ("_").

EXAMPLE: TSV_count.

Complete names as defined in the specifications are used.

6.1.1.7 Test case variable declarations

The test case variable identifiers are composed of substrings in lowercase letters, except for the prefix "TCV_". Each substring is separated by an underscore character ("_").

EXAMPLE: TCV_cr_value.

Complete names as defined in the specifications are used.

6.1.1.8 PCO declarations

The point of control and observation identifiers are composed of two or four capital letters, beginning with "L", as there are only LTs.

EXAMPLE: LMAC represents a PCO on MAC interface as LT in the test equipment.
LDLC represents a PCO on DLC interface as LT in the test equipment.

6.1.1.9 Timer declarations

Two types of timers can be identified:

1) standardized:

Those defined in the standard, e.g. T302, use exactly the same name as in the standard, beginning with a capital "T" if necessary.

As there is a tolerance margin accepted for these timers, three values are needed:

- the maximum value allowed, which will use the suffix "_max";
- the minimum value allowed, which will use the suffix "_min";
- the value actually implemented, with no suffix.

EXAMPLE 1: T302_max, T302_min, and T302.

2) not standardized:

- Those not defined in the standard, i.e. for execution use, e. g. a timer waiting for a response. These timers begin with the prefix "T_", followed by a string in lowercase letters.

EXAMPLE 2: T_resp represents a timer for controlling the response time of the IUT.

6.1.1.10 ASP type definitions

The identifier of an ASP uses exactly the nearest name as the name defined in the specifications. It is written in uppercases, finishing by an underscore character ("_"), and three capital letters indicating whether it is a request, an indication, a response or a confirmation primitive.

EXAMPLE: DL_RELEASE_REQ for an ASP requesting a release of the layer 2 link.

6.1.1.11 PDU type definitions

The identifier of a PDU is given in a string in uppercase letters, which represents the layer message.

EXAMPLE 1: DISCONNECT for the DISCONNECT layer 3 message.

Where the message is a composite word, an underscore character ("_") appears in the string.

EXAMPLE 2: RELEASE_COMPLETE is the RELEASE COMPLETE layer 3 message.

6.1.1.12 Alias definitions

These are used to make the sending and receiving of PDUs within ASPs more understandable when writing the dynamic part of the test suite. This is done by giving the ASP an alias. The alias name indicates the PDU carried by the ASP and whether it is sent or received by the tester.

Alias definitions are not used in the test suite.

6.1.2 Constraints part

This subclause describes the naming conventions chosen for the elements of the ATS constraints part.

Constraint identifiers commence with uppercase. The remaining part of the Id name is written in lowercase.

Identifier names of elements concerning the same subject have equivalent names in the declaration and the constraint part:

- Declaration Part: CC_SETUP;
- Constraint Part: Cc_setup.

The name of the modified constraint describes the particularity of the modified constraint:

EXAMPLE: Cc_setup_mand_only (modified Cc_setup with only the mandatory Information Elements).

If formal parameter lists are used, the variable names are written in lowercase. The variable name is the same as the name of the element it is representing.

Structured type constraints declarations are divided into:

- receive constraints:
 - the receive constraints are noted down as "name_rx*". The receive constraints are subdivided into:
 - receive base constraints:
 - they are noted down as "name_rx_base";
 - receive special constraints:
 - they are noted down as "name_rx_<extension>", where <extension> is a descriptive name (e.g. "Signal_rx_alerting_on");
 - transmit constraints:
 - the transmit constraints are noted down as "name_tx_<extension>", where <extension> is a descriptive name. (e.g. "Signal_tx_alerting_off").

If a certain structured type constraint is valid for both receiving and transmitting, because it contains no wildcards, and the receiving constraint should exactly match, the constraint will be noted down as:

- "<structured_type_name>_extention" Example: "Portable_id_ipui".

PDU Constraints Declarations are divided into:

- receive constraints:
 - the receive constraints are noted down as "name_rx*". The receive constraints are subdivided into:
 - receive base constraints:
 - they are noted down as "name_rx_base". They constrain all allowed values, and for the optional fields, the "IF_PRESENT" keyword is added;
 - receive special constraints:
 - they are noted down as "name_rx0n", where n is a sequence number;
 - transmit constraints:
 - the transmit constraints are noted down as "name_tx", where n is a sequence number. They can be subdivided into:
 - transmit base constraints:
 - they are noted down as "name_tx_base". They constrain all mandatory fields to all allowed values in the standard, and they constrain all optional fields to "OMIT";
 - transmit special constraints:
 - they are noted down as "name_tx0n" where n is a sequence number. They shall not contain any wildcards.

Derived constraints shall not be more than 1 level deep. They shall only be derived directly from the base constraint.

6.1.3 Dynamic part

This subclause describes the naming conventions chosen for the elements of the ATS dynamic part.

6.1.3.1 Test Case (TC) identifier

The identifier of a TC is built according to table 2.

Table 2: TC naming convention

Identifier:	DTC_PT_<fm>_<x>_<s>_<nn>		
	<fm> =	functional module	CC Call Control MM Mobility Management LC Link Control Entity IS Call Independent Supplementary Services CL Connectionless Message Service
	x =	Type of testing	CA Capability Tests BV Valid Behaviour Tests BO Inopportune Behaviour Tests TI Timer expiry and counter mismatch tests
	s =	Test subgroup	Empty if no subgroup OC Outgoing Call establishment CI Call Information CR Call Release SC Service Change RS Call Related Supplementary services SN Service Negotiation MP Multi-purposes tests HP Handover procedures SR Suspend and Resume procedures ID Identification AU Authentication LO Location AR Access Rights KA Key Allocation CH Ciphering LE Connection oriented Link Establishment LR Connection oriented Link Release
	<nn> =	sequential number	(01-99) Test Purpose Number

6.1.3.2 Test step identifier

The test step identifier is built with a string of lowercase letters led by a string of capital letter and joined by an underscore character. The first string indicates the main function of the test step; e.g. PR for preamble, PO for postamble, LTS for local tree name and STP for general step. The second string indicates the meaning of the step.

EXAMPLES: PR_name;
 PO_name;
 LTS_name;
 STP_name.

6.1.3.3 Default identifier

The Default identifiers begin with the prefix "DF_", followed by a string in lowercase letters.

6.1.3.4 Label identifier

All verdict assignments are labelled. To allow an exact identification in which table the verdict was assigned. The identifiers in the label column is built according to table 3.

Table 3: Naming convention for verdict assignment identifier

Identifier:	<Table><nn>		
	<Table> = type of table	TB	Test Body
		DF	DeFault
		PO	POstamble
		PR	PReamble
		TS	TestStep
	<nn> = sequential number	(00-99)	Label number

6.1.3.5 ATS abbreviations

These abbreviations are used to shorten identifier names:

ack	acknowledgement
addr	address
algo	algorithm
auth	authentication
cau	cause
cc	call control
cfm	confirm
est	establish
ext	extension
id	identification
ind	indication
info	information
max	maximum
mety	message type
min	minimum
mod	modified
par	parameter
pd	protocol discriminator
req	request
rsp	response

6.2 Implementation conventions

6.2.1 Declaration part

The comment line of single element TTCN tables (e.g. test suite constants) is used to give a reference where the format and content of the element is described in the relevant protocol specifications. Any particularity of the element format or content is described in the comment line.

The comment line in the header of multi element TTCN tables (e.g. ASPs) is used to reference to the protocol specification.

The detailed comments are used to describe any particularity of the table.

In the ASP and PDU declarations, the comments column is used to identify if an element is mandatory or optional:

- M: mandatory;
- O: optional.

In the ASP and PDU declarations the comments column is further used to give information about the element value, in particular if the element contains a fixed spare value.

In tables where structure types are used the information element and the relevant structured type have always the same name, that allows to have the same structure as in the protocol standards is used to document the relation between information elements in a table and their specific description in an other clause of the protocol standard.

The following conventions apply to identifier names in the Structured Type definitions part:

- bits of bit sequences having a fixed value, meant to fill up the octet, are called fn, where n stands for the octet number;
- extension flags, will be called extn, where n stands for the octet number.

6.2.2 Constraint part

The ASP and PDUs are defined in a way that all relevant element are parameterized. That improves the transparency of the constraints in the dynamic part, as all values which are relevant for the test are always present.

Generally no modified constraints are used, this allows an easier reuse and adaptation of constraints if they are reused in other test specifications.

The Comment line of a constraint always contains a reference to the relevant protocol standard.

The detailed comments footer is used to describe any particularity of the table.

6.2.3 Dynamic part

All events which are defined as a conformance requirements by the TP, cause a preliminary verdict PASS if the requirement is met.

All invalid events are handled in the default tree. Only FAIL verdicts can be assigned in the default tree.

The preamble, the test body and the postamble have different defaults, which allows a specific verdict handling, e.g. only INCONC verdicts are assigned in the preamble.

All verdict assignments are labelled. According to ISO/IEC 9646-3 [10], clause E.2, labels should be written to the conformance log. This allows, for example, to identify where the test failed. To allow an exact identification of the table in which the verdict was assigned, the convention described in subclause 6.1.3.4 is applied.

The labels of the same type are numbered sequentially if they are in the same TC, test step or default.

TP which are listed in the untestable TP list, or which reference to an other TP, e.g. BV TP which were already defined as CA TP, are not considered in the ATS, thus these TC identifiers are missing in the ATS and the numbering of the TCs is not always continued.

Annex A (normative): Abstract Test Suite (ATS)

This ATS has been produced using the Tree and Tabular Combined Notation (TTCN) according to ISO/IEC 9646-3 [10].

The ATS was developed on a separate TTCN software tool and therefore the TTCN tables are not completely referenced in the table of contents. The ATS itself contains a test suite overview Part which provides additional information and references.

A.1 The TTCN Graphical form (TTCN.GR)

The TTCN.GR representation of this ATS is contained in an Adobe Portable Document Format™ file (14690p8v02.PDF contained in archive en_30146908v010101p0.ZIP) which accompanies the present document.

A.2 The TTCN Machine Processable form (TTCN.MP)

The TTCN.MP representation corresponding to this ATS is contained in an ASCII file (1469p8v02.MP contained in archive en_30146908v010101p0.ZIP) which accompanies the present document.

NOTE: Where an ETSI Abstract Test Suite (in TTCN) is published in both .GR and .MP format these two forms shall be considered equivalent. In the event that there appears to be syntactical or semantic differences between the two then the problem shall be resolved and the erroneous format (whichever it is) shall be corrected.

Annex B (normative): Partial PIXIT proforma for DPRS NWK PT

Notwithstanding the provisions of the copyright clause related to the text of the present document, ETSI grants that users of the present document may freely reproduce the PIXIT proforma in this annex so that it can be used for its intended purposes and may further publish the completed PIXIT.

The PIXIT Proforma is based on ISO/IEC 9646-6 [11] . Any additional information needed can be found in the present document.

B.1 Identification summary

Table B.1

PIXIT Number:	
Test Laboratory Name:	
Date of Issue:	
Issued to:	

B.2 ATS summary

Table B.2

Protocol Specification:	EN 301 649 [6]
Protocol to be tested:	
ATS Specification:	EN 301 469-8
Abstract Test Method:	EN 301 469-8, clause 4

B.3 Test laboratory

Table B.3

Test Laboratory Identification:	
Test Laboratory Manager:	
Means of Testing:	
SAP Address:	

B.4 Client identification

Table B.4

Client Identification:	
Client Test manager:	
Test Facilities required:	

B.5 SUT

Table B.5

Name:	
Version:	
SCS Number:	
Machine configuration:	
Operating System Identification:	
IUT Identification:	
PICS Reference for IUT:	
Limitations of the SUT:	
Environmental Conditions:	

B.6 Protocol layer information

B.6.1 Protocol identification

Table B.6

Name:	DECT - NWK layer EN 301 649 [6]
Version:	
PICS References:	

B.6.2 IUT information

B.6.2.1 General configuration

Table B.7: General configuration

Item	Parameter	Parameter Type	Explanation and EN Reference	Value
1	TSPX_mmproc_auft_ccstate	CCSTATE_TYPE (INTEGER 1, 2, 3, 4, 5, 6, 7, 10, 19)	Indicates the PT cc state, the authentication of Fixed radio Termination (FT) test cases shall be tested in EN 300 175-5 [3] , subclause 13.3.3	
2	TSPX_mmproc_cipt_ccstate	CCSTATE_TYPE (INTEGER 1, 2, 3, 4, 5, 6, 7, 10, 19)	Indicates the PT cc state, the PT initiated ciphering test cases shall be tested in EN 300 175-5 [3] , subclause 13.8	
3	TSPX_mmproc_auft_invoke	MMPROC_TYPE (INTEGER 0 .. 10)	Indicates the way of invoking the authentication of FT procedure: EN 300 175-5 [3] , subclause 13.3.3	
4	TSPX_mmproc_cipt_invoke	MMPROC_TYPE (INTEGER 0 .. 10)	Indicates the way of invoking the PT initiated ciphering procedure: EN 300 175-5 [3] , subclause 13.8	
5	TSPX_nr_of_digits_in_cpn	INT_8 (INTEGER 0..255)	In order to facilitate testing, a number of digits less then 10 is advised. This parameter really indicates the number of CC_INFO messages to be expected during call setup.	
6	TSPX_onhook_aut	BOOLEAN	TRUE if the IUT automatically goes on-hook when the call is cleared.	
7	TSPX_lce_02	INTEGER	Value of Timer T_P_LCE_02 in milliseconds	
8	TSPX_dummy_bearer_duration	INTEGER	Value of wait timer used to delay the test case after setting up a second dummy bearer in case of intercell handover testing.	
9	TSPX_decay_rate	INTEGER	Ramp gradient for power down the RFP power. Used for the TSO equivalent to the MAC TSC_action7. Shall be between 0 and 10 dB/s	

Table B.8: Addresses

Item	Address name	Parameter Type	Explanation and EN Reference	Value
1	TSPX_decimal_ac_value	OCT_4 (OCTETSTRING [4])	Value of Authentication Code (AC) to be used. The AC will be entered as maximal 8 decimal digits. The AC to bitstring mapping will be done with operation TSO_cinpt_convert_ac_to_bitstring.	
2	TSPX_complete_fixed_id_ari_rpn_value	FIXED_ID_VALUE_TYPE (BITSTRING [8..72])	Value of fixed_id to be used in case of ARI + RPN (Radio Fixed Part Number) Reference: EN 300 175-5 [3] , subclause 7.7.18 40 bits starting with 0	
3	TSPX_complete_fixed_id_ari_rpn_value_2	FIXED_ID_VALUE_TYPE (BITSTRING[8..72])	Value of ARI + RPN fixed_id to be used for second subscription by IUT	
4	TSPX_complete_fixed_id_ari_rpn_nosub	FIXED_ID_VALUE_TYPE (BITSTRING[8..72])	Value of ARI + RPN fixed_id for which the IUT has no subscription. This is to be used as the RFPI of the LT during SARI and TARI tests. The value must be such that neither the following PARK subscription combination allows the IUT to lock: TSPX_complete_fixed_id_park_value + TSPX_park_length_indicator and TSPX_complete_fixed_id_park_value_2 + TSPX_park_length_indicator_2	
5	TSPX_complete_fixed_id_sari_nosub	FIXED_ID_VALUE_TYPE (BITSTRING[8..72])	Value of ARI + RPN fixed_id for which the IUT has no subscription. This is to be used as the SARI of the LT during TARI tests. It must differ from the ARI part of TSPX_complete_fixed_id_ari_rpn_nosub. The value must be such that neither the following PARK subscription combination allows the IUT to lock: TSPX_complete_fixed_id_park_value + TSPX_park_length_indicator and TSPX_complete_fixed_id_park_value_2 + TSPX_park_length_indicator_2	
6	TSPX_ipei_value	PORT_ID_VALUE_TYPE (BITSTRING[8..104])	Value of International Portable Equipment Identity (IPEI) (IPUI-N) to be expected from the IUT (before subscription). Fill up to 40 bits with leading 0s. Reference: EN 300 175-5 [3] , subclause 7.7.30	
7	TSPX_ipui_value	PORT_ID_VALUE_TYPE (BITSTRING[8..104])	Value of portable_id to be used in case of a International Portable User Identity (IPUI) (after subscription) Reference: EN 300 175-5 [3] , subclause 7.7.30	
8	TSPX_ipui_value_2	PORT_ID_VALUE_TYPE (BITSTRING[8..104])	Value of portable_id to be used in case of a second IPUI (after subscription) Reference: EN 300 175-5 [3], subclause 7.7.30	
9	TSPX_location_area_level	BIT_6 (BITSTRING[6])	The location area level that is going to be used Reference: EN 300 175-5 [3] , subclause 7.7.25	
10	TSPX_location_area_level_2	BIT_6 (BITSTRING[6])	The second location area level that is going to be used with the second FP (FP-2) during the change of subscription test.	

Item	Address name	Parameter Type	Explanation and EN Reference	Value
11	TSPX_complete_fixed_id_park_value	FIXED_ID_VALUE_TYPE (BITSTRING[8..72])	Value of fixed_id to be used in case of Portable Access Rights Key (PARK). PARK A 36 bits, PARK B, C, D - 31 bits Reference: EN 300 175-5 [3] , subclause 7.7.18	
12	TSPX_complete_fixed_id_park_value_2	FIXED_ID_VALUE_TYPE (BITSTRING[8..72])	Value of fixed_id to be used in case of a second PARK. PARK A 36 bits, PARK B, C, D - 31 bits. Reference: EN 300 175-5 [3] , subclause 7.7.18	
13	TSPX_tpui_value	PORT_ID_VALUE_TYPE (BITSTRING[8..104])	Value of tpui to be used, when assigning a tpui to the IUT Procedure EN 300 175-5 [3] , subclause 7.7.30	
14	TSPX_tpui2_value	PORT_ID_VALUE_TYPE (BITSTRING[8..104])	Value of tpui to be used, when assigning a second tpui to the IUT.	
15	TSPX_cl_tpui_value	PORT_ID_VALUE_TYPE (BITSTRING[8..104])	Value of CL TPUI to be used by the PT (LT). 20 bits value is required.	
16	TSPX_gr_tpui_value	PORT_ID_VALUE_TYPE (BITSTRING[8..104])	Value of GROUP TPUI to be used by the PT (LT). 20 bits value is required.	
17	TSPX_decimal_upi_value	OCT_4 (OCTETSTRING[4])	Value of UPI to be used. The UPI will be entered as maximal 8 decimal digits. The UPI to bitstring mapping will be done with operation TSO_cinpt_convert_upi_to_bitstring.	
18	TSPX_park_length_indicator	INTEGER	Number of significant bits in TSPX_park_value (PLI)	
19	TSPX_park_length_indicator_2	INTEGER	Number of significant bits in TSPX_park_value_2(PLI)	
20	TSPX_cap_min_sync	BOOLEAN	Is CAP profile feature N1 supported with minimum sync. between FP?	
21	TSPX_emergency_number_length	INTEGER	Length of the emergency number generated by the PP or typed by the operator.	
22	TSPX_pt_init_cipher_fp2	BOOLEAN	True if IUT uses PT initiated cipher switching after external handover setup, even if FT initiated cipher switching was used on first call	

Table B.9: Implicit send events

Item	PIXIT (see note)	Related implicit send message (PDU)	Indication how the implicit send event can be invoked
1	TSPX_change_location_area	To change the location area broadcasted by the LT. The location area is considered to be different to the one specified in STP_init_broadcast_bits. The implicit send will contain a DI_est_ind_no_pdu, because the IUT should begin link establishment, in order to perform location registration.	
2	TSPX_invoke_call_answering	To invoke the IUT to answer the incoming call. The IUT will go off hook when call present. Expected constraint: Cc_connect_rx_base	
3	TSPX_invoke_dialled_digit	To invoke the IUT to dial a digit.	
4	TSPX_invoke_dialling_pause	To invoke the IUT to make a dialling pause, the Cc_info constraint contains multi-keypad i.e. with the value "dialling pause" Expected constraint: Cc_info_rx03	
5	TSPX_invoke_dtmf_defined	To invoke the IUT to go to DTMF dialling with defined tone length, the Cc_info constraint contains a multi-keypad i.e. with the value "dtmf defined" Expected constraint: Cc_info_rx04	
6	TSPX_invoke_dtmf_infinite	To invoke the IUT to go to DTMF dialling with infinite tone length, the Cc_info constraint contains a multi-keypad i.e. with the value "dtmf infinite" Expected constraint: Cc_info_rx05	
7	TSPX_invoke_internal_call	To invoke the IUT to go off hook for an internal call setup, while in state T-00, a DL_EST_IND without a PDU is expected to be send by the IUT.	
8	TSPX_invoke_normal_release	To invoke the IUT to go on hook, thus initiating a normal release, while in any cc state. A dl_data_indication is to be expected, containing a CC_RELEASE message. Expected Constraint: Cc_release_rx_base	
9	TSPX_invoke_obtain_accessrights	To invoke the obtain access rights procedure, initiated by the IUT. A DI_est_ind_no_pdu is to be expected, because the IUT will start link establishment, in order to executed the obtain access rights procedure. The AC has to be entered in order to start the obtain access rights procedure. Expected Constraint: DI_est_ind_no_pdu	
10	TSPX_invoke_outgoing_call	To invoke the IUT to go off hook for a normal outgoing call setup, while in state T-00, a DL_EST_IND without a PDU is expected to be send by the IUT.	

Item	PIXIT (see note)	Related implicit send message (PDU)	Indication how the implicit send event can be invoked
11	TSPX_invoke_partial_release	To invoke the IUT to initiate a partial release. (when a link to the IUT is active), a CC_RELEASE message is expected, but no requirements on the release reason are made as the release reasons is optional in EN 300 444 [13] . Expected constraint: Cc_release_rx_base	
12	TSPX_invoke_pulse_dialling	To invoke the IUT to go to pulse, the Cc_info constraint contains multi-keypad i.e. with the value "goto pulse" Expected constraint: Cc_info_rx02	
13	TSPX_invoke_pt_init_cipherng	To invoke the PT to initiate cipherng on. A dl_data_ind is expected, containing a CIPHER-SUGGEST PDU. Expected constraint: Cipher_suggest_rx01	
14	TSPX_invoke_pt_off_cipherng	To invoke the PT to initiate cipherng off. A dl_data_ind is expected, containing a CIPHER-SUGGEST PDU. Expected Constraint: Cipher_suggest_rx02	
15	TSPX_invoke_register_recall	To invoke the IUT to initiate register recall, the Cc_info constraint contains multi-keypad i.e. with the value "register recall" Expected constraint: Cc_info_rx08	
16	TSPX_invoke_upi_entering	To enter the user personal identity at the PT. The user types in its upi, and after this a dl_data_ind is to be expected, containing an AUTH_REPLY message. The value of the UPI has to be specified in the PIXIT parameter TSPX_decimal_upi_value. Expected constraint: Auth_reply_rx_base	
17	TSPX_invoke_ft_authentication	To invoke the PT initiated FT authentication Expected constraint: Auth_req_rx_base	
NOTE: The PIXIT names are related to the test steps where the Implicit send events are handled, e.g. the PIXIT TSPX_invoke_abnormal_release is related to the test step STP_invoke_abnormal_release.			

Annex C (normative): Protocol Conformance Test Report (PCTR) Proforma for DPRS NWK PT

Notwithstanding the provisions of the copyright clause related to the text of the present document, ETSI grants that users of the present document may freely reproduce the PCTR proforma in this annex so that it can be used for its intended purposes and may further publish the completed PCTR.

The PCTR proforma is based on ISO/IEC 9646-6 [11] . Any additional information needed can be found in the present document.

C.1 Identification summary

C.1.1 Protocol conformance test report

Table C.1

PCTR Number:	
PCTR Date:	
Corresponding SCTR Number:	
Corresponding SCTR Date:	
Test Laboratory Identification:	
Test Laboratory Manager:	
Signature:	

C.1.2 IUT identification

Table C.2

Name:	
Version:	
Protocol specification:	
PICS:	
Previous PCTR if any:	

C.1.3 Testing environment

Table C.3

PIXIT Number:	
ATS Specification:	
Abstract Test Method:	Remote test method, Embedded variant with no UT
Means of Testing identification:	
Date of testing:	
Conformance Log reference(s):	
Retention Date for Log reference(s):	

C.1.4 Limits and reservation

Additional information relevant to the technical contents or further use of the test report, or the rights and obligations of the test laboratory and the client, may be given here. Such information may include restriction on the publication of the report.

.....

.....

.....

.....

.....

.....

C.1.5 Comments

Additional comments may be given by either the client or the test laboratory on any of the contents of the PCTR, for example, to note disagreement between the two parties.

.....

.....

.....

.....

.....

.....

C.2 IUT Conformance status

This IUT has or has not been shown by conformance assessment to be non conforming to the specified protocol specification.

Strike the appropriate words in this sentence. If the PICS for this IUT is consistent with the static conformance requirements (as specified in clause D.3 in this report) and there are no "FAIL" verdicts to be recorded (in clause D.6 in this report) strike the words "has or", otherwise strike the words "or has not".

C.3 Static conformance summary

The PICS for this IUT is or is not consistent with the static conformance requirements in the specified protocol.

Strike the appropriate words in this sentence.

C.4 Dynamic conformance summary

The test campaign did or did not reveal errors in the IUT.

Strike the appropriate words in this sentence. If there are no "FAIL" verdicts to be recorded (in clause D.6 of this report) strike the words "did or" otherwise strike the words "or did not".

Summary of the results of groups of test:

.....

.....

.....

.....

.....

.....

C.5 Static conformance review report

If clause D.3 indicates non-conformance, this subclause itemizes the mismatches between the PICS and the static conformance requirements of the specified protocol specification.

.....

.....

.....

.....

.....

.....

C.6 Test campaign report

Table C.4

ATS Reference	Selected?	Run?	Verdict	Observations (Reference to any observations made in clause 7)
DTC-PT-CC-BV-CI-02	Yes/No	Yes/No		
DTC-PT-CC-BV-CI-05	Yes/No	Yes/No		
DTC-PT-CC-BV-CI-06	Yes/No	Yes/No		
DTC-PT-CC-BV-CI-09	Yes/No	Yes/No		
DTC-PT-CC-BV-CI-10	Yes/No	Yes/No		
DTC-PT-CC-BV-CI-12	Yes/No	Yes/No		
DTC-PT-CC-BV-CI-13	Yes/No	Yes/No		
DTC-PT-CC-BV-CI-14	Yes/No	Yes/No		
DTC-PT-CC-BV-CR-01	Yes/No	Yes/No		
DTC-PT-CC-BV-CR-05	Yes/No	Yes/No		
DTC-PT-CC-BV-CR-06	Yes/No	Yes/No		
DTC-PT-CC-BV-CR-07	Yes/No	Yes/No		
DTC-PT-CC-BV-CR-09	Yes/No	Yes/No		
DTC-PT-CC-BV-CR-10	Yes/No	Yes/No		
DTC-PT-CC-BV-CR-11	Yes/No	Yes/No		
DTC-PT-CC-BV-SC-data01	Yes/No	Yes/No		
DTC-PT-CC-BV-SC-data02	Yes/No	Yes/No		
DTC-PT-CC-BV-SC-data03	Yes/No	Yes/No		
DTC-PT-CC-BV-SC-data04	Yes/No	Yes/No		
DTC-PT-CC-BV-SC-data05	Yes/No	Yes/No		
DTC-PT-CC-BV-SC-data06	Yes/No	Yes/No		
DTC-PT-CC-BV-SC-data07	Yes/No	Yes/No		
DTC-PT-CC-BV-SC-data08	Yes/No	Yes/No		
DTC-PT-CC-BV-SC-data09	Yes/No	Yes/No		

ATS Reference	Selected?	Run?	Verdict	Observations (Reference to any observations made in clause 7)
DTC-PT-CC-BV-RS-01	Yes/No	Yes/No		
DTC-PT-CC-BV-SN-data01	Yes/No	Yes/No		
DTC-PT-CC-BV-SN-data02	Yes/No	Yes/No		
DTC-PT-CC-BV-SN-data03	Yes/No	Yes/No		
DTC-PT-CC-BV-SN-data04	Yes/No	Yes/No		
DTC-PT-CC-BV-MP-data01	Yes/No	Yes/No		
DTC-PT-CC-BV-MP-data02	Yes/No	Yes/No		
DTC-PT-CC-BV-MP-data03	Yes/No	Yes/No		
DTC-PT-CC-BV-MP-data04	Yes/No	Yes/No		
DTC-PT-CC-BV-MP-data05	Yes/No	Yes/No		
DTC-PT-CC-BV-MP-data06	Yes/No	Yes/No		
DTC-PT-CC-BV-HP-50	Yes/No	Yes/No		
DTC-PT-CC-BV-HP-51	Yes/No	Yes/No		
DTC-PT-CC-BV-HP-52	Yes/No	Yes/No		
DTC-PT-CC-BV-HP-53	Yes/No	Yes/No		
DTC-PT-CC-BV-HP-54	Yes/No	Yes/No		
DTC-PT-CC-BV-HP-55	Yes/No	Yes/No		
DTC-PT-CC-BV-HP-56	Yes/No	Yes/No		
DTC-PT-CC-BV-HP-57	Yes/No	Yes/No		
DTC-PT-CC-BV-HP-58	Yes/No	Yes/No		
DTC-PT-CC-BV-HP-59	Yes/No	Yes/No		
DTC-PT-CC-BV-HP-60	Yes/No	Yes/No		
DTC-PT-CC-BV-HP-61	Yes/No	Yes/No		
DTC-PT-CC-BV-HP-62	Yes/No	Yes/No		
DTC-PT-CC-BV-HP-63	Yes/No	Yes/No		
DTC-PT-CC-BV-HP-64	Yes/No	Yes/No		
DTC-PT-CC-BV-HP-65	Yes/No	Yes/No		
DTC-PT-CC-BV-HP-66	Yes/No	Yes/No		
DTC-PT-CC-BV-HP-67	Yes/No	Yes/No		
DTC-PT-CC-BV-HP-68	Yes/No	Yes/No		
DTC-PT-CC-BV-HP-69	Yes/No	Yes/No		
DTC-PT-CC-BV-HP-70	Yes/No	Yes/No		
DTC-PT-CC-BV-HP-71	Yes/No	Yes/No		
DTC-PT-CC-BV-HP-72	Yes/No	Yes/No		
DTC-PT-CC-BV-HP-73	Yes/No	Yes/No		
DTC-PT-CC-BV-HP-74	Yes/No	Yes/No		
DTC-PT-CC-BV-HP-75	Yes/No	Yes/No		
DTC-PT-CC-BV-SR-data01	Yes/No	Yes/No		
DTC-PT-CC-BV-SR-data02	Yes/No	Yes/No		
DTC-PT-CC-BV-SR-data03	Yes/No	Yes/No		
DTC-PT-CC-BV-SR-data04	Yes/No	Yes/No		
DTC-PT-CC-BV-SR-data05	Yes/No	Yes/No		
DTC-PT-CC-BV-SR-data06	Yes/No	Yes/No		
DTC-PT-CC-BV-SR-data07	Yes/No	Yes/No		
DTC-PT-CC-BV-SR-data08	Yes/No	Yes/No		
DTC-PT-CC-BO-02	Yes/No	Yes/No		
DTC-PT-CC-TI-01	Yes/No	Yes/No		
DTC-PT-CC-TI-02	Yes/No	Yes/No		
DTC-PT-CC-TI-03	Yes/No	Yes/No		
DTC-PT-CC-TI-04	Yes/No	Yes/No		
DTC-PT-MM-BV-ID-01	Yes/No	Yes/No		
DTC-PT-MM-BV-ID-02	Yes/No	Yes/No		
DTC-PT-MM-BV-ID-08	Yes/No	Yes/No		
DTC-PT-MM-BV-ID-data01	Yes/No	Yes/No		
DTC-PT-MM-BV-ID-data02	Yes/No	Yes/No		
DTC-PT-MM-BV-AU-01	Yes/No	Yes/No		
DTC-PT-MM-BV-AU-02	Yes/No	Yes/No		
DTC-PT-MM-BV-AU-03	Yes/No	Yes/No		
DTC-PT-MM-BV-AU-04	Yes/No	Yes/No		
DTC-PT-MM-BV-AU-05	Yes/No	Yes/No		
DTC-PT-MM-BV-AU-07	Yes/No	Yes/No		

ATS Reference	Selected?	Run?	Verdict	Observations (Reference to any observations made in clause 7)
DTC-PT-MM-BV-AU-08	Yes/No	Yes/No		
DTC-PT-MM-BV-AU-09	Yes/No	Yes/No		
DTC-PT-MM-BV-LO-01	Yes/No	Yes/No		
DTC-PT-MM-BV-LO-02	Yes/No	Yes/No		
DTC-PT-MM-BV-LO-03	Yes/No	Yes/No		
DTC-PT-MM-BV-LO-04	Yes/No	Yes/No		
DTC-PT-MM-BV-LO-05	Yes/No	Yes/No		
DTC-PT-MM-BV-LO-06	Yes/No	Yes/No		
DTC-PT-MM-BV-LO-07	Yes/No	Yes/No		
DTC-PT-MM-BV-LO-08	Yes/No	Yes/No		
DTC-PT-MM-BV-LO-09	Yes/No	Yes/No		
DTC-PT-MM-BV-LO-10	Yes/No	Yes/No		
DTC-PT-MM-BV-LO-50	Yes/No	Yes/No		
DTC-PT-MM-BV-LO-51	Yes/No	Yes/No		
DTC-PT-MM-BV-LO-52	Yes/No	Yes/No		
DTC-PT-MM-BV-LO-53	Yes/No	Yes/No		
DTC-PT-MM-BV-LO-54	Yes/No	Yes/No		
DTC-PT-MM-BV-LO-55	Yes/No	Yes/No		
DTC-PT-MM-BV-LO-56	Yes/No	Yes/No		
DTC-PT-MM-BV-LO-57	Yes/No	Yes/No		
DTC-PT-MM-BV-LO-58	Yes/No	Yes/No		
DTC-PT-MM-BV-LO-59	Yes/No	Yes/No		
DTC-PT-MM-BV-LO-60	Yes/No	Yes/No		
DTC-PT-MM-BV-AR-01	Yes/No	Yes/No		
DTC-PT-MM-BV-AR-03	Yes/No	Yes/No		
DTC-PT-MM-BV-AR-05	Yes/No	Yes/No		
DTC-PT-MM-BV-AR-06	Yes/No	Yes/No		
DTC-PT-MM-BV-AR-09	Yes/No	Yes/No		
DTC-PT-MM-BV-AR-10	Yes/No	Yes/No		
DTC-PT-MM-BV-AR-50	Yes/No	Yes/No		
DTC-PT-MM-BV-AR-51	Yes/No	Yes/No		
DTC-PT-MM-BV-AR-52	Yes/No	Yes/No		
DTC-PT-MM-BV-AR-53	Yes/No	Yes/No		
DTC-PT-MM-BV-KA-01	Yes/No	Yes/No		
DTC-PT-MM-BV-KA-02	Yes/No	Yes/No		
DTC-PT-MM-BV-KA-03	Yes/No	Yes/No		
DTC-PT-MM-BV-CH-01	Yes/No	Yes/No		
DTC-PT-MM-BV-CH-02	Yes/No	Yes/No		
DTC-PT-MM-BV-CH-03	Yes/No	Yes/No		
DTC-PT-MM-BV-CH-04	Yes/No	Yes/No		
DTC-PT-MM-BV-CH-05	Yes/No	Yes/No		
DTC-PT-MM-BV-CH-09	Yes/No	Yes/No		
DTC-PT-MM-BV-CH-10	Yes/No	Yes/No		
DTC-PT-MM-BV-CH-11	Yes/No	Yes/No		
DTC-PT-MM-BV-CH-12	Yes/No	Yes/No		
DTC-PT-MM-BV-CH-13	Yes/No	Yes/No		
DTC-PT-MM-BV-CH-14	Yes/No	Yes/No		
DTC-PT-MM-BV-CH-15	Yes/No	Yes/No		
DTC-PT-MM-BV-CH-data01	Yes/No	Yes/No		
DTC-PT-MM-TI-01	Yes/No	Yes/No		
DTC-PT-MM-TI-02	Yes/No	Yes/No		
DTC-PT-MM-TI-03	Yes/No	Yes/No		
DTC-PT-MM-TI-04	Yes/No	Yes/No		
DTC-PT-MM-TI-05	Yes/No	Yes/No		
DTC-PT-LC-BV-LE-01	Yes/No	Yes/No		
DTC-PT-LC-BV-LE-02	Yes/No	Yes/No		
DTC-PT-LC-BV-LE-data01	Yes/No	Yes/No		
DTC-PT-LC-BV-LE-data02	Yes/No	Yes/No		
DTC-PT-LC-BV-LE-data03	Yes/No	Yes/No		
DTC-PT-LC-BV-LE-data04	Yes/No	Yes/No		
DTC-PT-LC-BV-LR-01	Yes/No	Yes/No		

Bibliography

The following material, though not specifically referenced in the body of the present document (or not publicly available), gives supporting information.

ETSI EN 300 175-2: "Digital Enhanced Cordless Telecommunications (DECT); Common Interface (CI); Part 2: Physical Layer (PHL)".

ETSI EN 300 175-3: "Digital Enhanced Cordless Telecommunications (DECT); Common Interface (CI); Part 3: Medium Access Control (MAC) layer".

ETSI EN 300 175-8: "Digital Enhanced Cordless Telecommunications (DECT); Common Interface (CI); Part 8: Speech coding and transmission".

ETSI ETS 300 435: "Digital Enhanced Cordless Telecommunications (DECT); Data Services Profile (DSP); Base standard including interworking to connectionless networks (service types A and B, class 1)".

ETSI ETS 300 651: "Digital Enhanced Cordless Telecommunications (DECT); Data Services Profile (DSP); Generic data link service (service type C, class 2)".

ETSI ETS 300 699: "Digital Enhanced Cordless Telecommunications (DECT); Data Services Profile (DSP); Generic data link service for closed user groups (service type C, class 1)".

ETSI ETS 300 701: "Digital Enhanced Cordless Telecommunications (DECT); Data Services Profile (DSP); Generic frame relay service with mobility (service types A and B, class 2)".

ETSI ETS 300 755: "Digital Enhanced Cordless Telecommunications (DECT); Data Services Profile (DSP); Multimedia Messaging Service (MMS) with specific provision for facsimile services (service type F, class 2)".

ETSI EN 300 757: "Digital Enhanced Cordless Telecommunications (DECT); Low Rate Messaging Service (LRMS); including Short Messaging Service (SMS)".

ETSI EN 301 240: "Digital Enhanced Cordless Telecommunications (DECT); Data Services Profile (DSP); Point-to-Point Protocol (PPP) interworking for internet access and general multi-protocol datagram transport".

History

Document history		
V0.0.2	November 1999	Public Enquiry PE 200012: 1999-11-24 to 2000-03-24
V0.0.3	August 2000	Vote V 20001013: 2000-08-14 to 2000-10-13
V1.1.1	October 2000	Publication