

# ETSI EN 301 469-5 V1.1.1 (2000-10)

---

*European Standard (Telecommunications series)*

**Digital Enhanced Cordless Telecommunications (DECT);  
DECT Packet Radio Service (DPRS) Test Case Library (TCL);  
Part 5: Abstract Test Suite (ATS) -  
Data Link Control (DLC) layer -  
Portable radio Termination (PT)**

---



---

**Reference**

DEN/DECT-040047-5

---

**Keywords**ATS, DECT, DPRS, layer 2, testing, ATS-GR file,  
ATS-MP file, TSS&TP, data**ETSI**

---

650 Route des Lucioles  
F-06921 Sophia Antipolis Cedex - FRANCE

Tel.: +33 4 92 94 42 00 Fax: +33 4 93 65 47 16

Siret N° 348 623 562 00017 - NAF 742 C  
Association à but non lucratif enregistrée à la  
Sous-Préfecture de Grasse (06) N° 7803/88

---

**Important notice**

Individual copies of the present document can be downloaded from:

<http://www.etsi.org>

The present document may be made available in more than one electronic version or in print. In any case of existing or perceived difference in contents between such versions, the reference version is the Portable Document Format (PDF). In case of dispute, the reference shall be the printing on ETSI printers of the PDF version kept on a specific network drive within ETSI Secretariat.

Users of the present document should be aware that the document may be subject to revision or change of status. Information on the current status of this and other ETSI documents is available at <http://www.etsi.org/tb/status/>

If you find errors in the present document, send your comment to:  
editor@etsi.fr

---

**Copyright Notification**

No part may be reproduced except as authorized by written permission.  
The copyright and the foregoing restriction extend to reproduction in all media.

© European Telecommunications Standards Institute 2000.  
All rights reserved.

# Contents

|  |           |
|--|-----------|
| Intellectual Property Rights .....                                       | 5         |
| Foreword.....  | 5         |
| 1 Scope .....  | 6         |
| 2 References .....   | 6         |
| 3 Definitions and abbreviations.....                                     | 7         |
| 3.1 Definitions .....  | 7         |
| 3.2 Abbreviations .....  | 7         |
| 4 Abstract Test Method (ATM).....  | 7         |
| 5 Untestable Test Purposes (TP) .....                                    | 8         |
| 6 ATS Conventions .....  | 9         |
| 6.1 Naming conventions.....  | 9         |
| 6.1.1 Declarations part.....   | 9         |
| 6.1.1.1 Test suite type and structured type definitions .....            | 9         |
| 6.1.1.2 Test suite operations definitions.....                           | 9         |
| 6.1.1.3 Test suite parameter declarations .....                          | 9         |
| 6.1.1.4 Test case selection expression definitions .....                 | 10        |
| 6.1.1.5 Test suite constant declarations.....                            | 10        |
| 6.1.1.6 Test suite variable declarations .....                           | 10        |
| 6.1.1.7 Test case variable declarations .....                            | 10        |
| 6.1.1.8 PCO declarations.....  | 10        |
| 6.1.1.9 Timer declarations.....  | 10        |
| 6.1.1.10 ASP type definitions .....                                      | 11        |
| 6.1.1.11 PDU type definitions.....                                       | 11        |
| 6.1.1.12 Alias definitions .....   | 11        |
| 6.1.2 Constraints part.....  | 11        |
| 6.1.3 Dynamic part .....   | 11        |
| 6.1.3.1 Test Case (TC) identifier.....                                   | 12        |
| 6.1.3.2 Test step identifier.....  | 12        |
| 6.1.3.3 Default identifier .....   | 12        |
| 6.1.3.4 Label identifier .....   | 12        |
| 6.1.3.5 ATS abbreviations.....   | 12        |
| 6.2 Implementation conventions .....                                     | 13        |
| 6.2.1 Declaration part .....   | 13        |
| 6.2.2 Constraint part .....  | 13        |
| 6.2.3 Dynamic part .....   | 13        |
| <b>Annex A (normative): Abstract Test Suite (ATS).....</b>               | <b>14</b> |
| A.1 The TTCN Graphical form (TTCN.GR) .....                              | 14        |
| A.2 The TTCN Machine Processable form (TTCN.MP).....                     | 14        |
| <b>Annex B (normative): Partial PIXIT proforma for DPRS DLC PT .....</b> | <b>15</b> |
| B.1 Identification summary.....  | 15        |
| B.2 ATS summary .....  | 15        |
| B.3 Test laboratory.....   | 15        |
| B.4 Client identification.....   | 16        |
| B.5 SUT .....  | 16        |
| B.6 Protocol layer information.....                                      | 16        |
| B.6.1 Protocol identification .....                                      | 16        |

|  |                                       |           |
|--|---------------------------------------|-----------|
| B.6.2  | IUT information .....                 | 17        |
| B.6.2.1  | General configuration .....           | 17        |
| B.6.2.2  | Parameter values .....                | 17        |
| B.6.2.3  | Timer values .....                    | 17        |
| B.6.2.4  | Network parameter values .....        | 18        |
| B.6.3  | Procedural Information.....           | 18        |
| B.6.3.1  | Class U procedural information .....  | 18        |
| B.6.3.2  | Class A procedural information .....  | 19        |
| B.6.3.3  | Paging procedural information .....   | 20        |
| B.6.3.4  | Class 0 procedural information.....   | 21        |
| B.6.3.5  | Class 1 procedural information.....   | 21        |
| B.6.3.6  | Class 2 procedural information.....   | 22        |
| <b>Annex C (normative):      Protocol Conformance Test Report (PCTR) Proforma for DPRS</b> |                                       |           |
|  | <b>  DLC PT.....</b>                  | <b>23</b> |
| C.1  | Identification summary.....           | 23        |
| C.1.1  | Protocol conformance test report..... | 23        |
| C.1.2  | IUT identification .....              | 23        |
| C.1.3  | Testing environment.....              | 24        |
| C.1.4  | Limits and reservation .....          | 24        |
| C.1.5  | Comments.....                         | 24        |
| C.2  | IUT Conformance status .....          | 25        |
| C.3  | Static conformance summary .....      | 25        |
| C.4  | Dynamic conformance summary.....      | 25        |
| C.5  | Static conformance review report..... | 25        |
| C.6  | Test campaign report .....            | 26        |
| C.7  | Observations.....                     | 27        |
|  | Bibliography .....                    | 28        |
|  | History .....                         | 29        |

---

## Intellectual Property Rights

IPRs essential or potentially essential to the present document may have been declared to ETSI. The information pertaining to these essential IPRs, if any, is publicly available for **ETSI members and non-members**, and can be found in ETSI SR 000 314: "*Intellectual Property Rights (IPRs); Essential, or potentially Essential, IPRs notified to ETSI in respect of ETSI standards*", which is available from the ETSI Secretariat. Latest updates are available on the ETSI Web server (<http://www.etsi.org/ipr>).

Pursuant to the ETSI IPR Policy, no investigation, including IPR searches, has been carried out by ETSI. No guarantee can be given as to the existence of other IPRs not referenced in ETSI SR 000 314 (or the updates on the ETSI Web server) which are, or may be, or may become, essential to the present document.

---

## Foreword

This European Standard (Telecommunications series) has been produced by ETSI Project Digital Enhanced Cordless Telecommunications (DECT).

The present document is part 5 of a multi-part deliverable covering the Digital Enhanced Cordless Telecommunications (DECT); DECT Packet Radio Service (DPRS) Test Case Library (TCL), as identified below:

- Part 1: "Test Suite Structure (TSS) and Test Purposes (TP) - Medium Access Control (MAC) layer";
- Part 2: "Abstract Test Suite (ATS) - Medium Access Control (MAC) layer - Portable radio Termination (PT)";
- Part 3: "Abstract Test Suite (ATS) - Medium Access Control (MAC) layer - Fixed radio Termination (FT)";
- Part 4: "Test Suite Structure (TSS) and Test Purposes (TP) - Data Link Control (DLC) layer";
- Part 5: "Abstract Test Suite (ATS) - Data Link Control (DLC) layer - Portable radio Termination (PT)";**
- Part 6: "Abstract Test Suite (ATS) - Data Link Control (DLC) layer - Fixed radio Termination (FT)";
- Part 7: "Test Suite Structure (TSS) and Test Purposes (TP) - Network (NWK) layer";
- Part 8: "Abstract Test Suite (ATS) - Network (NWK) layer - Portable radio Termination (PT)";
- Part 9: "Abstract Test Suite (ATS) - Network (NWK) layer - Fixed radio Termination (FT)".

| <b>National transposition dates</b>  |                 |
|--|-----------------|
| Date of adoption of this EN:   | 13 October 2000 |
| Date of latest announcement of this EN (doa):  | 31 January 2001 |
| Date of latest publication of new National Standard or endorsement of this EN (dop/e): | 31 July 2001    |
| Date of withdrawal of any conflicting National Standard (dow):                         | 31 July 2001    |

---

# 1 Scope

The present document contains the Abstract Test Suite (ATS) specification to test the DECT Packet Radio Service (DPRS) Data Link Control (DLC) layer at the Portable radio Termination (PT).

The objective of this test specification is to provide a basis for conformance tests for DECT equipment giving a high probability of air interface inter-operability between different manufacturer's DECT equipment.

The ISO standard for the methodology of conformance testing (ISO/IEC 9646-1 [4] and ISO/IEC 9646-2 [5]) as well as the ETSI rules for conformance testing (ETS 300 406 [3]) are used as a basis for the test methodology.

Annex A provides the Tree and Tabular Combined Notation (TTCN) part of this ATS.

Annex B provides the Partial Protocol Implementation Extra Information for Testing (PIXIT) Proforma of this ATS.

Annex C provides the Protocol Conformance Test Report (PCTR) Proforma of this ATS.

---

# 2 References

The following documents contain provisions which, through reference in this text, constitute provisions of the present document.

- References are either specific (identified by date of publication, edition number, version number, etc.) or non-specific.
- For a specific reference, subsequent revisions do not apply.
- For a non-specific reference, the latest version applies.
- A non-specific reference to an ETS shall also be taken to refer to later versions published as an EN with the same number.

- [1] ETSI EN 300 175-3: "Digital Enhanced Cordless Telecommunications (DECT); Common Interface (CI); Part 3: Medium Access Control (MAC) layer".
- [2] ETSI EN 300 175-4: "Digital Enhanced Cordless Telecommunications (DECT); Common Interface (CI); Part 4: Data Link Control (DLC) layer".
- [3] ETSI ETS 300 406: "Methods for Testing and Specification (MTS); Protocol and profile conformance testing specifications; Standardization methodology".
- [4] ISO/IEC 9646-1: "Information technology - Open Systems Interconnection - Conformance testing methodology and framework - Part 1: General concepts". (See also ITU-T Recommendation X.290).
- [5] ISO/IEC 9646-2: "Information technology - Open Systems Interconnection - Conformance testing methodology and framework - Part 2: Abstract test suite specification". (See also ITU-T Recommendation X.291).
- [6] ISO/IEC 9646-3: "Information technology - Open Systems Interconnection - Conformance testing methodology and framework - Part 3: The tree and tabular combined notation". (See also ITU-T Recommendation X.292).
- [7] ISO/IEC 9646-6: "Information technology - Open Systems Interconnection - Conformance testing methodology and framework - Part 6: Protocol profile test specification".
- [8] ISO/IEC 9646-7: "Information technology - Open Systems Interconnection - Conformance testing methodology and framework - Part 7: Implementation conformance statement".
- [9] ETSI EN 301 649: "Digital Enhanced Cordless Telecommunications (DECT); DECT Packet Radio Services (DPRS)".

---

## 3 Definitions and abbreviations

### 3.1 Definitions

For the purposes of the present document, the following terms and definitions apply:

- a) the terms given in ISO/IEC 9646-1 [4]; and
- b) the definitions given in EN 300 175-4 [2].

### 3.2 Abbreviations

For the purposes of the present document, the abbreviations given in ISO/IEC 9646-1 [4], ISO/IEC 9646-6 [7], ISO/IEC 9646-7 [8] and EN 300 175-4 [2] apply. In particular, the following abbreviations apply:

|       |   |
|-------|---|
| ASP   | Abstract Service Primitive                            |
| ATM   | Abstract Test Method                                  |
| ATS   | Abstract Test Suite                                   |
| BI    | Invalid Behaviour                                     |
| BO    | Inopportune Behaviour                                 |
| BV    | Valid Behaviour                                       |
| CA    | Capability tests                                      |
| DLC   | Data Link Control                                     |
| FP    | Fixed Part  |
| FT    | Fixed radio Termination                               |
| IUT   | Implementation Under Test                             |
| LT    | Lower Tester  |
| MAC   | Medium Access Control                                 |
| NWK   | Network   |
| PCO   | Point of Control and Observation                      |
| PDU   | Protocol Data Unit                                    |
| PICS  | Protocol Implementation Conformance Statement         |
| PIXIT | Protocol Implementation Extra Information for Testing |
| PMID  | Portable Part MAC Identity                            |
| PP    | Portable Part   |
| PT    | Portable radio Termination                            |
| RF    | Radio Frequency                                       |
| RFP   | Radio Fixed Part                                      |
| SAP   | Service Access Point                                  |
| SUT   | System Under Test                                     |
| TC    | Test Case   |
| TDMA  | Time Division Multiple Access                         |
| TP    | Test Purposes   |
| TSS   | Test Suite Structure                                  |
| TTCN  | Tree and Tabular Combined Notation                    |
| UT    | Upper Tester  |

---

## 4 Abstract Test Method (ATM)

This clause describes the ATM used for testing the DECT DLC protocol. It is the embedded variant of Remote Single (RSE) layer test method. The RSE test method has been selected, because:

- this test method implies no specific requirements from the IUT;
- the Upper Service Access Point (USAP) of the IUT cannot be directly observed;
- the variety of the possible DECT implementations is a serious technical obstacle for the adoption of a different ATM;

- this test method places the minimum limitations in the realization of conformance testing.

The embedded variant of the remote test method provides sufficient control of the IUT DLC behaviour, through NWK layer messages conveyed by DLC frames.

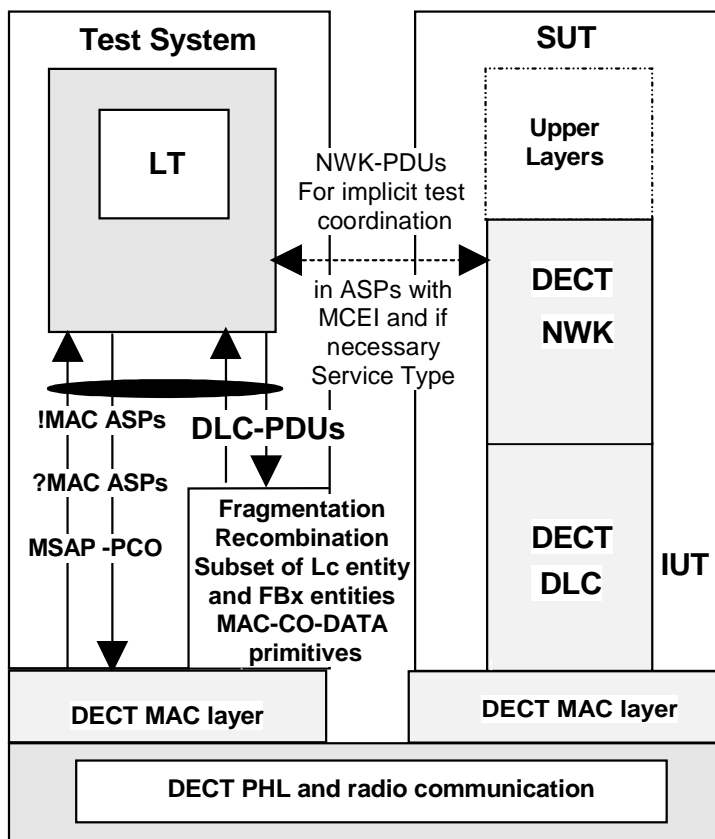

Figure 1: RS test Method embedded variant

- LT** A Lower Tester (LT) is located in a remote DECT test system. It controls and observes the behaviour of the IUT.
- MSAP** MAC Service Access Point - A unique MAC SAP is defined at the DECT interface and used to exchange service data of the DLC protocol. To avoid the complexity of data fragmentation and recombination testing, the SAP is defined below this functions of the DLC layer.
- PCO** The PCO for DLC layer testing is located on the MSAP. All test events at the PCO are specified in terms of MAC Abstract Service Primitives (ASPs) and DLC layer Protocol Data Units (PDUs).
- Notional UT** No explicit upper tester (UT) exists in the system under test. Nevertheless, some network messages are sent to the SUT for the need of the co-ordination procedures. The network layer of the SUT is used as a notional UT as defined in ISO 9646.

The MAC primitives are defined according to EN 300 175-3 [1] clause 8 and associated subclauses.

## 5 Untestable Test Purposes (TP)

Due to the ATM chosen for this ATS or other restrictions, the test purposes in table 1 have been identified as being in the untestable category, and therefore have not been derived into final test case:



Table 0: Untestable TP

| Test purpose | Reason |
|--------------|--------|
|              |        |
|              |        |

## 6 ATS Conventions

This clause describes the conventions applied to define the ATS and gives the naming conventions chosen for the different elements of the ATS.

The ATS conventions are intended to give a better understanding of the ATS but they describe also the conventions made for the development of the ATS, thus for any later maintenance purposes or further development of the ATS the conventions described in this clause shall be considered.

The ATS conventions contain two subclauses, the naming conventions and the implementation conventions. The naming conventions describe the structure of the naming of all ATS elements. The implementation conventions describe the functional structure of the ATS.

To define the ATS, the guidelines of ETS 300 406 [3] was considered.

### 6.1 Naming conventions

#### 6.1.1 Declarations part

This subclause describes the naming conventions chosen for the elements of the ATS declarations part.

##### 6.1.1.1 Test suite type and structured type definitions

The test suite type and test suite structured type identifiers describe the information elements, and are written in uppercase:

EXAMPLE:     PROTOCOL\_DISCRIMINATOR simple type.  
               FILLSTRING structured type.

##### 6.1.1.2 Test suite operations definitions

The test suite operation identifiers are composed of substrings in lowercase letters, except for standard prefix "TSO\_". Each substring is separated by an underscore character ("\_").

EXAMPLE:     TSO\_compute\_checksum.

##### 6.1.1.3 Test suite parameter declarations

The test suite parameter identifiers are composed of substrings in lowercase letters, except for the standard prefix "TSP\_". Each substring is separated by an underscore character ("\_").

EXAMPLE:     TSP\_window\_size.

If the test suite parameter references a Protocol Implementation Conformance Statement (PICS) item, the letter "C" is added to the standard prefix.

EXAMPLE:     TSPC\_pics\_item\_s23.

If the test suite parameter references a PIXIT item, the letter "X" is added to the standard prefix.

EXAMPLE:     TSPX\_pixit\_item\_2.

#### 6.1.1.4 Test case selection expression definitions

The naming conventions for the test case selection expression definitions use free text starting with an uppercase letter. The name of the expression shall explain clearly the selection rule. The test case selection expressions are logical combinations of the test suite parameters definitions.

#### 6.1.1.5 Test suite constant declarations

The test suite constant identifiers are composed of substrings in lowercase letters, except for the prefix "TSC\_". Each substring is separated by an underscore character ("\_").

EXAMPLE: TSC\_retry.

Complete names as defined in the specifications are used.

#### 6.1.1.6 Test suite variable declarations

The test suite variable identifiers are composed of substrings in lowercase letters, except for the prefix "TSV\_". Each substring is separated by an underscore character ("\_").

EXAMPLE: TSV\_count.

**Exception:** If the test suite variable represents a system parameter or value, the name defined in the specifications is used.

EXAMPLE: VR,VS.

#### 6.1.1.7 Test case variable declarations

The test case variable identifiers are composed of substrings in lowercase letters, except for the prefix "TCV\_". Each substring is separated by an underscore character ("\_").

EXAMPLE: TCV\_cr\_value.

#### 6.1.1.8 PCO declarations

The point of control and observation identifiers are composed of two or four capital letters, beginning with "L", as there are only LTs.

EXAMPLE: LMAC represents a PCO on MAC interface as LT in the test equipment.  
LDLC represents a PCO on DLC interface as LT in the test equipment.

#### 6.1.1.9 Timer declarations

Two kinds of timers can be distinguished:

1) standardized:

Those defined in the standard, e.g. DL\_04, use exactly the same name as in the standard, beginning with a capital "T".

As there is a tolerance margin accepted for these timers, three values are needed:

- the maximum value allowed, which will use the suffix "\_max";
- the minimum value allowed, which will use the suffix "\_min";
- the value actually implemented, with no suffix.

EXAMPLE 1: TDL\_04\_max, TDL\_04\_min, and TDL\_04.

2) not standardized:

- Those not defined in the standard, i.e. for execution use, e. g. a timer waiting for a response. These timers begin with the prefix "T\_", followed by a string in lowercase letters.

EXAMPLE 2: T\_resp represents a timer for controlling the response time of the IUT.

#### 6.1.1.10 ASP type definitions

The identifier of an ASP uses exactly the nearest name as the name defined in the specifications. It is written in uppercases, finishing by an underscore character ("\_"), and three capital letters indicating whether it is a request, an indication, a response or a confirmation primitive.

EXAMPLE: DL\_RELEASE\_REQ for an ASP containing a layer 3 release request passed to layer 2;  
MAC\_DATA\_REQ for an ASP containing a layer 2b PDU passed to layer 2a.

#### 6.1.1.11 PDU type definitions

The identifier of a PDU is given in a string in uppercase letters, which represents the layer message.

EXAMPLE 1: RR for the Receive Ready layer 2 message;  
DISCONNECT for the DISCONNECT layer 3 message.

Where the message is a composite word, an underscore character ("\_") appears in the string.

EXAMPLE 2: RELEASE\_COMPLETE is the RELEASE COMPLETE layer 3 message.

#### 6.1.1.12 Alias definitions

These are used to make the sending and receiving of PDUs within ASPs more understandable when writing the dynamic part of the test suite. This is done by giving the ASP an alias. The alias name indicates the PDU carried by the ASP and whether it is sent or received by the tester.

Alias definitions are not used in the test suite.

### 6.1.2 Constraints part

This subclause describes the naming conventions chosen for the elements of the ATS constraints part.

Constraint identifiers commence with uppercase. The remaining part of the Id name is written in lowercase.

Identifier names of elements concerning the same subject have equivalent names in the declaration and the constraint part:

- Declaration Part: CC\_SETUP;
- Constraint Part: Cc\_setup.

The name of the modified constraint describes the particularity of the modified constraint.

EXAMPLE: Cc\_setup\_mand\_only (modified Cc\_setup with only the mandatory Information Elements).

If formal parameter lists are used, the variable names are written in lowercase. The variable name is the same as the name of the element it is representing.

### 6.1.3 Dynamic part

This subclause describes the naming conventions chosen for the elements of the ATS dynamic part.

### 6.1.3.1 Test Case (TC) identifier

The identifier of a TC is built according to table 1.

**Table 1: TC naming convention**

| Identifier: | DTC_PT_<fm>_x_<nnn>       |           |                                  |
|-------------|---------------------------|-----------|----------------------------------|
|             | <fm> = functional module  | U         | Control plane Class U services   |
|             |                           | A         | Control plane Class A services   |
|             |                           | L         | Control plane Broadcast services |
|             |                           | 0         | User plane transmission Class 0  |
|             |                           | 1         | User plane transmission Class 1  |
|             |                           | 2         | User plane transmission Class 2  |
|             |                           | 3         | User plane transmission Class 3  |
|             | x = Type of testing       | CA        | CA, Capability tests             |
|             |                           | BV        | BV, Valid Behaviour tests        |
|             |                           | BO        | BO, Inopportune Behaviour tests  |
|             |                           | BI        | BI, Invalid Behaviour tests      |
|             | <nnn> = sequential number | (000-999) | test case Number                 |

### 6.1.3.2 Test step identifier

The test step identifier is built with a string of lowercase letters led by a string of capital letter and joined by an underscore character. The first string indicates the main function of the test step; e.g. PR for preamble, PO for postamble, LTS for local tree name and STP for general step. The second string indicates the meaning of the step.

EXAMPLES: PR\_name;  
PO\_name;  
LTS\_name;  
STP\_name.

### 6.1.3.3 Default identifier

The Default identifiers begin with the prefix "DF\_", followed by a string in lowercase letters.

### 6.1.3.4 Label identifier

All verdict assignments are labelled. To allow an exact identification in which table the verdict was assigned. The identifiers in the label column is built according to table 2:

**Table 2: Naming convention for verdict assignment identifier**

| Identifier: | <Table><nn>              |         |              |
|-------------|--------------------------|---------|--------------|
|             | <Table> = type of table  | TB      | Test Body    |
|             |                          | DF      | DeFault      |
|             |                          | PO      | POstamble    |
|             |                          | PR      | PReamble     |
|             |                          | TS      | TestStep     |
|             | <nn> = sequential number | (00-99) | Label number |

### 6.1.3.5 ATS abbreviations

These abbreviations are used to shorten identifier names:

|      |                 |
|------|-----------------|
| ack  | acknowledgement |
| addr | address         |
| cau  | cause           |
| cc   | call control    |
| chn  | channel         |
| est  | establish       |
| ind  | indication      |

|      |                        |
|------|------------------------|
| mety | message type           |
| mod  | modified               |
| par  | parameter              |
| pd   | protocol discriminator |
| req  | request                |
| rsp  | response               |

## 6.2 Implementation conventions

### 6.2.1 Declaration part

The comment line of single element TTCN tables (e.g. test suite constants) is used to give a reference where the format and content of the element is described in the relevant protocol specifications. Any particularity of the element format or content is described in the comment line.

The comment line in the header of multi element TTCN tables (e.g. ASPs) is used to reference to the protocol specification.

The detailed comments are used to describe any particularity of the table.

In the ASP and PDU declarations, the comments column is used to identify if an element is mandatory or optional:

- M: mandatory;
- O: optional.

In the ASP and PDU declarations the comments column is further used to give information about the element value, in particular if the element contains a fixed spare value.

### 6.2.2 Constraint part

The ASPs and PDUs are defined in a way that all relevant element are parameterized. That improves the transparency of the constraints in the dynamic part, as all values which are relevant for the test are always present.

Generally no modified constraints are used, this allows an easier reuse and adaptation of constraints if they are reused in other test specifications.

The Comment line of a constraint always contains a reference to the relevant protocol standard.

The detailed comments footer is used to describe any particularity of the table.

### 6.2.3 Dynamic part

All events which are defined as a conformance requirements by the TP, cause a preliminary verdict PASS if the requirement is met.

All invalid events are handled in the default tree. Only FAIL verdicts can be assigned in the default tree.

The preamble, the test body and the postamble have different defaults, which allows a specific verdict handling, e.g. only INCONC verdicts are assigned in the preamble.

All verdict assignments are labelled. According to ISO 9646-3 [6], clause E.2, labels should be written to the conformance log. This allows, for example, to identify where the test failed. To allow an exact identification of the table in which the verdict was assigned, the convention described in subclause 6.1.3.4 is applied.

The labels of the same type are numbered sequentially if they are in the same TC, test step or default.

TP which are listed in the untestable TP list, or which reference to an other TP, e.g. BV TP which were already defined as CA TP, are not considered in the ATS, thus these TC identifiers are missing in the ATS and the numbering of the TCs is not always continues.

---

## Annex A (normative): Abstract Test Suite (ATS)

This ATS has been produced using the Tree and Tabular Combined Notation (TTCN) according to ISO/IEC 9646-3 [6].

The ATS was developed on a separate TTCN software tool and therefore the TTCN tables are not completely referenced in the table of contents. The ATS itself contains a test suite overview part which provides additional information and references.

---

### A.1 The TTCN Graphical form (TTCN.GR)

The TTCN.GR representation of this ATS is contained in an Adobe Portable Document Format™ file (1469p5v02.PDF contained in archive en\_30146905v010101p0.ZIP) which accompanies the present document.

---

### A.2 The TTCN Machine Processable form (TTCN.MP)

The TTCN.MP representation corresponding to this ATS is contained in an ASCII file (1469p5v02.MP contained in archive en\_30146905v010101p0.ZIP) which accompanies the present document.

**NOTE:** Where an ETSI Abstract Test Suite (in TTCN) is published in both .GR and .MP format these two forms shall be considered equivalent. In the event that there appears to be syntactical or semantic differences between the two then the problem shall be resolved and the erroneous format (whichever it is) shall be corrected.

---

## Annex B (normative): Partial PIXIT proforma for DPRS DLC PT

Notwithstanding the provisions of the copyright clause related to the text of the present document, ETSI grants that users of the present document may freely reproduce the PIXIT proforma in this annex so that it can be used for its intended purposes and may further publish the completed PIXIT.

The PIXIT Proforma is based on ISO/IEC 9646-6 [7]. Any additional information needed can be found in the present document.

---

### B.1 Identification summary

**Table B.1**

|                       |  |
|-----------------------|--|
| PIXIT Number:         |  |
| Test Laboratory Name: |  |
| Date of Issue:        |  |
| Issued to:            |  |

---

### B.2 ATS summary

**Table B.2**

|                         |                        |
|-------------------------|------------------------|
| Protocol Specification: | EN 301 649 [9]         |
| Protocol to be tested:  |                        |
| ATS Specification:      | EN 301 469-5           |
| Abstract Test Method:   | EN 301 469-5, clause 4 |

---

### B.3 Test laboratory

**Table B.3**

|                                 |  |
|---------------------------------|--|
| Test Laboratory Identification: |  |
| Test Laboratory Manager:        |  |
| Means of Testing:               |  |
| SAP Address:                    |  |

---

## B.4 Client identification

Table B.4

|                           |  |
|---------------------------|--|
| Client Identification:    |  |
| Client Test manager:      |  |
| Test Facilities required: |  |

---

## B.5 SUT

Table B.5

|                                  |  |
|----------------------------------|--|
| Name:                            |  |
| Version:                         |  |
| SCS Number:                      |  |
| Machine configuration:           |  |
| Operating System Identification: |  |
| IUT Identification:              |  |
| PICS Reference for IUT:          |  |
| Limitations of the SUT:          |  |
| Environmental Conditions:        |  |

---

## B.6 Protocol layer information

### B.6.1 Protocol identification

Table B.6

|                  |                                 |
|------------------|---------------------------------|
| Name:            | DECT - DLC layer EN 301 649 [9] |
| Version:         |                                 |
| PICS References: |                                 |



## B.6.2 IUT information

### B.6.2.1 General configuration

**Table B.7: General configuration**

| Item | Parameter | Parameter Type | Explanation   | Value |
|------|-----------|----------------|---|-------|
| 1    | TSPX_chn  | BOOLEAN        | Indicate the desired signalling channel for testing signalling procedure (For I <sub>N</sub> or I <sub>P</sub> testing only C <sub>S</sub> channel is used). For C <sub>S</sub> write FALSE and write TRUE for C <sub>F</sub> |       |
| 2    | TSPX_slot | SLOT_TYPE      | Indicate the slot type to be use in MAC connection for the test suite (Half = 0 - Full = 1 - Double = 2)  |       |

### B.6.2.2 Parameter values

**Table B.8: Parameter values**

| Item | Parameter                  | Parameter Type | Explanation   | Value |
|------|----------------------------|----------------|---|-------|
| 1    | TSPX_n250                  | INTEGER        | Indicate the value of the re-transmission counter for Class A establishment procedure.  |       |
| 2    | TSPX_k1                    | INTEGER        | If supported, indicate the value of Class 1 sending window.   |       |
| 3    | TSPX_rpn                   | RPN            | FT's Radio fixed Part Number.   |       |
| 4    | TSPX_rpn1                  | RPN            | Second FT's Radio fixed Part Number for Intercell Handover.   |       |
| 5    | TSPX_dummy_bearer_duration | INTEGER        | Value of wait timer used to delay the test case after setting up a second dummy bearer in case of intercell handover testing.                 |       |
| 6    | TSPX_intracell_behaviour   | INTEGER        | Value 0,1 for handling intracell bearer handover<br>0 = Normal tester behaviour<br>1 = force tester to ignore all intracell handover request. |       |
| 7    | TSPX_decay_rate            | INTEGER        | Ramp gradient for power down the RFP power. Used for the TSO equivalent to the MAC TSC_action7. Shall be between 0 dB/s and 10 dB/s.          |       |

### B.6.2.3 Timer values

**Table B.9: Timer values**

| Item | Parameter        | Parameter Type | Type  | Value |
|------|------------------|----------------|---|-------|
| 1    | TSPX_dl04_value  | INTEGER        | Indicate the value of the Class A established state re-transmission timer |       |
| 2    | TSPX_dl07_value  | INTEGER        | Indicate the value of the Class A establishment timer                     |       |
| 3    | TSPX_dlu01_value | INTEGER        | Indicate the of the Class 1 timer   |       |

## B.6.2.4 Network parameter values

**Table B.10: Network parameter values**

| Item | Parameter          | Parameter Type    | Explanation                                   | Value |
|------|--------------------|-------------------|---|-------|
| 1    | TSPX_ari           | ARI               | Access Rights Identity                        |       |
| 2    | TSPX_pmid_assigned | PMID              | Portable MAC Identity                         |       |
| 3    | TSPX_fid           | FIXED_IDENTITY    | Fixed Identity                                |       |
| 4    | TSPX_pid           | PORTABLE_IDENTITY | Portable Identity                             |       |
| 5    | TSPX_ipui_class    | IPUI-CLASS        | Class of international portable user identity |       |
| 6    | TSPX_ipui          | BITSTRING         | International Portable User Identity          |       |

## B.6.3 Procedural Information

### B.6.3.1 Class U procedural information

**Table B.11: Class U reception procedural information**

| Item | Parameter                | Parameter Type       | Explanation  | Value         |
|------|--------------------------|----------------------|--|---------------|
| 1    | TSPX_cu_receive_on_co    | BOOLEAN              | In case of an open Mac connection exist, the IUT is able to receive Class U information frame (UI frame) in this connection?   | TRUE<br>FALSE |
| 2    | TSPX_cu_rec_proc_defined | BOOLEAN              | Is it possible to determine if the IUT received a Class U information frame (UI frame)?  | TRUE<br>FALSE |
| 3    | TPSPX_ui_pdu_on_co       | BITSTRING            | If item 1 and item 2 are TRUE:<br>Indicate in the following lines the desired information field for the UI frame.<br>.....<br>.....  |               |
|      | TSO_iut_ui_received      | Test suite Operation | If item 1 and item 2 are TRUE:<br>Indicate in the following lines the procedure to determine the reception of the UI frame.<br>.....<br>.....<br>.....<br>.....<br>.....         |               |
| 4    | TPSPX_ui_pdu_on_cl       | BITSTRING            | If item 1 is FALSE and item 2 is TRUE:<br>Indicate in the following lines the desired information field for the UI frame.<br>.....<br>.....                                      |               |
|      | TSO_iut_ui_received      | Test suite Operation | If item 1 is FALSE and item 2 is TRUE:<br>Indicate in the following lines the procedure to determine the reception of the UI frame.<br>.....<br>.....<br>.....<br>.....<br>..... |               |

Table B.12: Class U transmission procedural information

| Item | Parameter  | Parameter Type | Explanation  | Value         |
|------|--|----------------|--|---------------|
| 1    | TSPX_cu_snd_proc_defined   | BOOLEAN        | Is it possible to force the IUT to transmit a Class U information frame (UI frame)?  | TRUE<br>FALSE |
|      | STP_invoke_uplink_data for PT part<br>STP_invoke_downlink_data for FT part | Implicit Send  | If TRUE:<br>Indicate in the following lines the procedure to transmit the UI frame.<br>.....<br>.....<br>.....<br>.....<br>..... |               |

## B.6.3.2 Class A procedural information

Table B.13: Class A procedural information

| Item | Parameter                      | Parameter Type | Explanation   | Value         |
|------|--------------------------------|----------------|---|---------------|
| 1    | TSPX_ca_accept_est             | BOOLEAN        | Does the IUT react properly in case of reception of the Class A establishment request?  | TRUE<br>FALSE |
| 2    | TSPX_ca_re_establish_invoke    | BOOLEAN        | Only if the IUT is a Portable Part (PP): Is it possible to force the IUT to initiate Class A link re-establishment?   | TRUE<br>FALSE |
|      | STP_invoke_ca_re_establishment | Implicit Send  | If item 2 is TRUE:<br>Indicate in the following lines the procedure to force the IUT to re-establish the Class A link.<br>.....<br>.....<br>.....<br>.....<br>..... |               |
| 3    | TSPX_ca_initiate_est           | BOOLEAN        | Is the IUT able to initiate Class A link establishment?   | TRUE<br>FALSE |

## B.6.3.3 Paging procedural information

Table B.14: Paging procedural information

| Item | Parameter             | Parameter Type | Explanation  | Value         |
|------|-----------------------|----------------|--|---------------|
| 1    | TSPX_lbs_proc_defined | BOOLEAN        | Only if the IUT is a Fixed Part (FP): Is it possible to force the IUT to transmit a LCE-PAGE-REQUEST message in short format (3 octets)?   | TRUE<br>FALSE |
|      | STP_invoke_short_page | Implicit Send  | If item 1 is TRUE:<br>Indicate in the following lines the procedure to force the transmission of the LCE-PAGE-REQUEST message in short format.<br>.....<br>.....<br>.....<br>..... |               |
| 2    | TSPX_lbl_proc_defined | BOOLEAN        | Only if the IUT is a FP: Is it possible to force the IUT to transmit a LCE-PAGE-REQUEST message in long format (5 octets)?   | TRUE<br>FALSE |
|      | STP_invoke_long_page  | Implicit Send  | If item 2 is TRUE:<br>Indicate in the following lines the procedure to force the transmission of the LCE-PAGE-REQUEST message in long format.<br>.....<br>.....<br>.....<br>.....  |               |

### B.6.3.4 Class 0 procedural information

**Table B.15: Class 0 procedural information**

| Item | Parameter                | Parameter Type       | Explanation  | Value         |
|------|--------------------------|----------------------|--|---------------|
| 1    | TSPX_in_rec_proc_defined | BOOLEAN              | Is it possible to determine if the IUT received a Class 0 FU1 In frame?  | TRUE<br>FALSE |
| 2    | TSPX_in_pdu              | OCTETSTRING          | If item 1 is TRUE:<br>Indicate in the following lines the desired information field for the FU1 frame.<br>.....<br>.....                             |               |
|      | TSPX_iut_in_received     | Test suite Operation | If item 1 is TRUE:<br>Indicate in the following lines the procedure to determine the reception of the FU1 frame.<br>.....<br>.....<br>.....<br>..... |               |
| 3    | TSPX_fu1_snd_pr_defined  | BOOLEAN              | Is it possible to force the IUT to transmit a Class 0 FU1 frame?   | TRUE<br>FALSE |
|      | STP_invoke_fu1_frame     | Implicit Send        | If item 3 is TRUE:<br>Indicate in the following lines the procedure to force the IUT to transmit the FU1 frame.<br>.....<br>.....<br>.....<br>.....  |               |

### B.6.3.5 Class 1 procedural information

**Table B.16: Class 1 procedural information**

| Item | Parameter               | Parameter Type | Explanation   | Value         |
|------|-------------------------|----------------|---|---------------|
| 1    | TSPX_uln                | ULN            | Indicate the value of the U plane link number (ULN) used on the first IP service for FU5 frame.   |               |
| 2    | TSPX_lrc1_value         | INTEGER        | Indicate the duration (in seconds) of the buffering period of out of sequence frame(s). (L(R) Time Division Multiple Access (TDMA) frames).         |               |
| 3    | TSPX_fu5_snd_pr_defined | BOOLEAN        | Is it possible to force the IUT to transmit a Class 1 FU5 frame?  | TRUE<br>FALSE |
|      | STP_invoke_fu5_frame    | Implicit Send  | If item 3 is TRUE:<br>Indicate in the following lines the procedure to force the IUT to transmit the FU5 frame.<br>.....<br>.....<br>.....<br>..... |               |

## B.6.3.6 Class 2 procedural information

Table B.17: Class 2 procedural information

| Item | Parameter                | Parameter Type        | Explanation   | Value |
|------|--------------------------|-----------------------|---|-------|
| 1    | TSPX_bs                  | BASIC_SERVICE         | BASIC_SERVICE for establishing a LU10 service                               |       |
| 2    | TSP_iwu_attrib           | IWU_ATTRIBUTES_2      | IWU_ATTRIBUTES for establishing a LU10 service (IUT is the sender)          |       |
| 3    | TSP_iwu_attrib_r         | IWU_ATTRIBUTES_2      | second IWU_ATTRIBUTES for establishing a LU10 service (IUT is the receiver) |       |
| 4    | TSPX_call_attrib         | CALL_ATTRIBUTES       | CALL_ATTRIBUTES; for establishing a LU10 service (IUT is the sender)        |       |
| 5    | TSPX_call_attrib_r       | CALL_ATTRIBUTES       | CALL_ATTRIBUTES; for establishing a LU10 service (IUT is the receiver)      |       |
| 6    | TSPX_connection_attrib   | CONNECTION_ATTRIBUTES | CONNECTION_ATTRIBUTES for establishing a LU10 service (IUT is the sender)   |       |
| 7    | TSPX_connection_attrib_r | CONNECTION_ATTRIBUTES | CONNECTION_ATTRIBUTES for establishing a LU10 service (IUT is the receiver) |       |
| 8    | TSPX_connection_id       | CONNECTION_ID         | CONNECTION_ID for establishing a LU10 service (IUT is the sender)           |       |
| 9    | TSPX_connection_id_r     | CONNECTION_ID         | CONNECTION_ID for establishing a LU10 service (IUT is the receiver)         |       |
| 10   | TSPX_transit_delay       | TRANSIT_DELAY         | TRANSIT_DELAY for establishing a LU10 service (IUT is the sender)           |       |
| 11   | TSPX_transit_delay_r     | TRANSIT_DELAY         | TRANSIT_DELAY for establishing a LU10 service (IUT is the receiver)         |       |
| 12   | TSPX_window_size         | WINDOW_SIZE           | WINDOW_SIZE for establishing a LU10 service                                 |       |
| 13   | TSPX_window_size_small   | WINDOW_SIZE           | a small WINDOW_SIZE for establishing a LU10 service                         |       |

---

## Annex C (normative): Protocol Conformance Test Report (PCTR) Proforma for DPRS DLC PT

|  |
|--|
| Notwithstanding the provisions of the copyright clause related to the text of the present document, ETSI grants that users of the present document may freely reproduce the PCTR proforma in this annex so that it can be used for its intended purposes and may further publish the completed PCTR. |
|--|

The PCTR proforma is based on ISO/IEC 9646-6 [7] . Any additional information needed can be found in the present document.

---

### C.1 Identification summary

#### C.1.1 Protocol conformance test report

**Table C.1**

|                                 |  |
|---------------------------------|--|
| PCTR Number:                    |  |
| PCTR Date:                      |  |
| Corresponding SCTR Number:      |  |
| Corresponding SCTR Date:        |  |
| Test Laboratory Identification: |  |
| Test Laboratory Manager:        |  |
| Signature:                      |  |

#### C.1.2 IUT identification

**Table C.2**

|                         |  |
|-------------------------|--|
| Name:                   |  |
| Version:                |  |
| Protocol specification: |  |
| PICS:                   |  |
| Previous PCTR if any:   |  |

### C.1.3 Testing environment

**Table C.3**

|                                      |   |
|--------------------------------------|---|
| PIXIT Number:                        |   |
| ATS Specification:                   |   |
| Abstract Test Method:                | Remote test method, Embedded variant with no UT |
| Means of Testing identification:     |   |
| Date of testing:                     |   |
| Conformance Log reference(s):        |   |
| Retention Date for Log reference(s): |   |

### C.1.4 Limits and reservation

Additional information relevant to the technical contents or further use of the test report, or the rights and obligations of the test laboratory and the client, may be given here. Such information may include restriction on the publication of the report.

.....

.....

.....

.....

.....

.....

.....

### C.1.5 Comments

Additional comments may be given by either the client or the test laboratory on any of the contents of the PCTR, for example, to note disagreement between the two parties.

.....

.....

.....

.....

.....

.....

.....



---

## C.2 IUT Conformance status

This IUT has or has not been shown by conformance assessment to be non conforming to the specified protocol specification.

*Strike the appropriate words in this sentence. If the PICS for this IUT is consistent with the static conformance requirements (as specified in clause D.3 in this report) and there are no "FAIL" verdicts to be recorded (in clause D.6 in this report) strike the words "has or",. otherwise strike the words "or has not".*

---

## C.3 Static conformance summary

The PICS for this IUT is or is not consistent with the static conformance requirements in the specified protocol.

*Strike the appropriate words in this sentence.*

---

## C.4 Dynamic conformance summary

The test campaign did or did not reveal errors in the IUT.

*Strike the appropriate words in this sentence. If there are no "FAIL" verdicts to be recorded (in clause D.6 of this report) strike the words "did or" otherwise strike the words "or did not".*

Summary of the results of groups of test:

.....  
.....  
.....  
.....  
.....  
.....  
.....

---

## C.5 Static conformance review report

If clause D.3 indicates non-conformance, this subclause itemizes the mismatches between the PICS and the static conformance requirements of the specified protocol specification.

.....  
.....  
.....  
.....  
.....  
.....

## C.6 Test campaign report

Table C.4

| ATS Reference      | Selected? | Run?   | Verdict | Observations<br>(Reference to any observations made<br>in clause 7) |
|--------------------|-----------|--------|---------|---|
| DTC-PT-U-CA-000    | Yes/No    | Yes/No |         |   |
| DTC-PT-U-CA-002    | Yes/No    | Yes/No |         |   |
| DTC-PT-U-CA-003    | Yes/No    | Yes/No |         |   |
| DTC-PT-U-BI-000    | Yes/No    | Yes/No |         |   |
| DTC-PT-U-BI-001    | Yes/No    | Yes/No |         |   |
| DTC-PT-U-BI-002    | Yes/No    | Yes/No |         |   |
| DTC-PT-U-BI-003    | Yes/No    | Yes/No |         |   |
| DTC-PT-U-BI-004    | Yes/No    | Yes/No |         |   |
| DTC-PT-U-BI-005    | Yes/No    | Yes/No |         |   |
| DTC-PT-U-BI-006    | Yes/No    | Yes/No |         |   |
| DTC-PT-U-BI-007    | Yes/No    | Yes/No |         |   |
| DTC-PT-A-CA-000    | Yes/No    | Yes/No |         |   |
| DTC-PT-A-CA-001    | Yes/No    | Yes/No |         |   |
| DTC-PT-A-CA-002    | Yes/No    | Yes/No |         |   |
| DTC-PT-A-CA-003    | Yes/No    | Yes/No |         |   |
| DTC-PT-A-CA-005    | Yes/No    | Yes/No |         |   |
| DTC-PT-A-CA-006    | Yes/No    | Yes/No |         |   |
| DTC-PT-A-CA-007    | Yes/No    | Yes/No |         |   |
| DTC-PT-A-CA-008    | Yes/No    | Yes/No |         |   |
| DTC-PT-A-BV-000    | Yes/No    | Yes/No |         |   |
| DTC-PT-A-BV-002    | Yes/No    | Yes/No |         |   |
| DTC-PT-A-BV-003    | Yes/No    | Yes/No |         |   |
| DTC-PT-A-BV-005    | Yes/No    | Yes/No |         |   |
| DTC-PT-A-BV-006    | Yes/No    | Yes/No |         |   |
| DTC-PT-A-BV-007    | Yes/No    | Yes/No |         |   |
| DTC-PT-A-BV-008    | Yes/No    | Yes/No |         |   |
| DTC-PT-A-BI-000    | Yes/No    | Yes/No |         |   |
| DTC-PT-A-BI-001    | Yes/No    | Yes/No |         |   |
| DTC-PT-A-BI-002    | Yes/No    | Yes/No |         |   |
| DTC-PT-A-BI-003    | Yes/No    | Yes/No |         |   |
| DTC-PT-A-BI-004    | Yes/No    | Yes/No |         |   |
| DTC-PT-A-BI-005    | Yes/No    | Yes/No |         |   |
| DTC-PT-A-BI-006    | Yes/No    | Yes/No |         |   |
| DTC-PT-A-BI-007    | Yes/No    | Yes/No |         |   |
| DTC-PT-A-BI-008    | Yes/No    | Yes/No |         |   |
| DTC-PT-A-BI-009    | Yes/No    | Yes/No |         |   |
| DTC-PT-A-BI-011    | Yes/No    | Yes/No |         |   |
| DTC-PT-A-BI-012    | Yes/No    | Yes/No |         |   |
| DTC-PT-A-BI-013    | Yes/No    | Yes/No |         |   |
| DTC-PT-A-BO-000    | Yes/No    | Yes/No |         |   |
| DTC-PT-A-BO-001    | Yes/No    | Yes/No |         |   |
| DTC-PT-A-BO-002    | Yes/No    | Yes/No |         |   |
| DTC-PT-A-BO-003    | Yes/No    | Yes/No |         |   |
| DTC-PT-L-CA-000    | Yes/No    | Yes/No |         |   |
| DTC-PT-L-CA-001    | Yes/No    | Yes/No |         |   |
| DTC-PT-L-CA-data00 | Yes/No    | Yes/No |         |   |
| DTC-PT-L-CA-data01 | Yes/No    | Yes/No |         |   |
| DTC-PT-0-CA-000    | Yes/No    | Yes/No |         |   |
| DTC-PT-0-CA-001    | Yes/No    | Yes/No |         |   |
| DTC-PT-1-CA-000    | Yes/No    | Yes/No |         |   |
| DTC-PT-1-CA-001    | Yes/No    | Yes/No |         |   |
| DTC-PT-1-CA-002    | Yes/No    | Yes/No |         |   |
| DTC-PT-1-BV-000    | Yes/No    | Yes/No |         |   |
| DTC-PT-1-BV-001    | Yes/No    | Yes/No |         |   |

| ATS Reference      | Selected? | Run?   | Verdict | Observations<br>(Reference to any observations made<br>in clause 7) |
|--------------------|-----------|--------|---------|---|
| DTC-PT-1-BV-002    | Yes/No    | Yes/No |         |   |
| DTC-PT-1-BI-000    | Yes/No    | Yes/No |         |   |
| DTC-PT-1-BI-001    | Yes/No    | Yes/No |         |   |
| DTC-PT-1-BI-002    | Yes/No    | Yes/No |         |   |
| DTC-PT-2-BV-data00 | Yes/No    | Yes/No |         |   |
| DTC-PT-2-BV-data01 | Yes/No    | Yes/No |         |   |
| DTC-PT-2-BV-data02 | Yes/No    | Yes/No |         |   |
| DTC-PT-2-BV-data03 | Yes/No    | Yes/No |         |   |
| DTC-PT-2-BV-data04 | Yes/No    | Yes/No |         |   |
| DTC-PT-2-BV-data05 | Yes/No    | Yes/No |         |   |
| DTC-PT-2-BV-data06 | Yes/No    | Yes/No |         |   |
| DTC-PT-2-BV-data07 | Yes/No    | Yes/No |         |   |
| DTC-PT-2-BV-data08 | Yes/No    | Yes/No |         |   |
| DTC-PT-2-BV-data09 | Yes/No    | Yes/No |         |   |
| DTC-PT-2-BV-data10 | Yes/No    | Yes/No |         |   |
| DTC-PT-2-BV-data11 | Yes/No    | Yes/No |         |   |
| DTC-PT-2-BV-data12 | Yes/No    | Yes/No |         |   |

---

## C.7 Observations

Additional information relevant to the technical content of the PCTR is given here.

.....

.....

.....

.....

.....

.....

---

## Bibliography

The following material, though not specifically referenced in the body of the present document (or not publicly available), gives supporting information.

ETSI EN 300 175-1: "Digital Enhanced Cordless Telecommunications (DECT); Common Interface (CI); Part 1: Overview".

ETSI EN 300 175-2: "Digital Enhanced Cordless Telecommunications (DECT); Common Interface (CI); Part 2: Physical Layer (PHL)".

ETSI EN 300 175-5: "Digital Enhanced Cordless Telecommunications (DECT); Common Interface (CI); Part 5: Network (NWK) layer".

ETSI EN 300 175-6: "Digital Enhanced Cordless Telecommunications (DECT); Common Interface (CI); Part 6: Identities and addressing".

ETSI EN 300 175-7: "Digital Enhanced Cordless Telecommunications (DECT); Common Interface (CI); Part 7: Security features".

ETSI EN 300 175-8: "Digital Enhanced Cordless Telecommunications (DECT); Common Interface (CI); Part 8: Speech coding and transmission".

ETSI ETS 300 435: "Digital Enhanced Cordless Telecommunications (DECT); Data Services Profile (DSP); Base standard including interworking to connectionless networks (service types A and B, class 1)".

ETSI ETS 300 651: "Digital Enhanced Cordless Telecommunications (DECT); Data Services Profile (DSP); Generic data link service (service type C, class 2)".

ETSI ETS 300 699: "Digital Enhanced Cordless Telecommunications (DECT); Data Services Profile (DSP); Generic data link service for closed user groups (service type C, class 1)".

ETSI ETS 300 701: "Digital Enhanced Cordless Telecommunications (DECT); Data Services Profile (DSP); Generic frame relay service with mobility (service types A and B, class 2)".

ETSI ETS 300 755: "Digital Enhanced Cordless Telecommunications (DECT); Data Services Profile (DSP); Multimedia Messaging Service (MMS) with specific provision for facsimile services (service type F, class 2)".

ETSI EN 300 757: "Digital Enhanced Cordless Telecommunications (DECT); Low Rate Messaging Service (LRMS); including Short Messaging Service (SMS)".

ETSI EN 301 240: "Digital Enhanced Cordless Telecommunications (DECT); Data Services Profile (DSP); Point-to-Point Protocol (PPP) interworking for internet access and general multi-protocol datagram transport".

---

## History

| <b>Document history</b> |               |  |
|-------------------------|---------------|--|
| V0.0.2                  | November 1999 | Public Enquiry PE 200012: 1999-11-24 to 2000-03-24 |
| V0.0.3                  | August 2000   | Vote V 20001013: 2000-08-14 to 2000-10-13          |
| V1.1.1                  | October 2000  | Publication  |
|                         |               |  |
|                         |               |  |