

**Digital Enhanced Cordless Telecommunications (DECT);  
DECT Packet Radio Service (DPRS) Test Case Library (TCL);  
Part 3: Abstract Test Suite (ATS) - Medium Access  
Control (MAC) layer - Fixed radio Termination (FT)**

---



---

**Reference**

---

DEN/DECT-040047-3 (dlor001c.PDF)

---

**Keywords**

---

ATS, ATS\_GR file, ATS\_MP file, data, DECT,  
DPRS, MAC, testing, TTCN**ETSI**

---

**Postal address**

---

F-06921 Sophia Antipolis Cedex - FRANCE

---

**Office address**

---

650 Route des Lucioles - Sophia Antipolis  
Valbonne - FRANCE  
Tel.: +33 4 92 94 42 00 Fax: +33 4 93 65 47 16  
Siret N° 348 623 562 00017 - NAF 742 C  
Association à but non lucratif enregistrée à la  
Sous-Préfecture de Grasse (06) N° 7803/88

---

**Internet**

---

secretariat@etsi.fr  
Individual copies of this ETSI deliverable  
can be downloaded from  
<http://www.etsi.org>  
If you find errors in the present document, send your  
comment to: editor@etsi.fr

---

**Important notice**

This ETSI deliverable may be made available in more than one electronic version or in print. In any case of existing or perceived difference in contents between such versions, the reference version is the Portable Document Format (PDF). In case of dispute, the reference should be the printing on ETSI printers of the PDF version kept on a specific network drive within ETSI Secretariat.

---

**Copyright Notification**

No part may be reproduced except as authorized by written permission.  
The copyright and the foregoing restriction extend to reproduction in all media.

© European Telecommunications Standards Institute 1999.  
All rights reserved.

# Contents

Intellectual Property Rights .....	5
Foreword .....	5
1 Scope .....	6
2 References .....	6
3 Definitions and abbreviations .....	7
3.1 Definitions .....	7
3.2 Abbreviations .....	7
4 Abstract Test Method (ATM) .....	8
4.1 Description of ATM .....	8
4.2 Test strategy .....	9
5 Untestable Test Purposes (TP) .....	10
6 ATS conventions (only applicable for PTC LT_TC) .....	10
6.1 Naming conventions .....	10
6.1.1 Declarations part .....	10
6.1.1.1 General .....	10
6.1.1.2 Test suite operations definition .....	10
6.1.1.3 Test suite parameter declarations .....	11
6.1.1.4 Test case selection expression definition .....	11
6.1.1.5 Test suite constant declarations .....	11
6.1.1.6 Test suite variable declarations .....	11
6.1.1.7 Test case variable declarations .....	11
6.1.1.8 Timer declarations .....	11
6.1.1.9 ASP type definitions .....	12
6.1.1.10 PDU type definitions .....	12
6.1.1.11 CM type definitions .....	12
6.1.1.12 Alias definitions .....	12
6.1.2 Constraints part .....	12
6.1.2.1 General .....	12
6.1.3 Dynamic part .....	12
6.1.3.1 General .....	12
6.1.3.2 Test Case (TC) identifier .....	12
6.1.3.3 Test step identifier .....	13
6.1.3.4 Default identifier .....	13
6.1.3.5 Label identifier .....	13
6.1.3.6 ATS abbreviations .....	14
6.2 Implementation conventions .....	14
6.2.1 Declaration part .....	14
6.2.2 Constraint part .....	14
6.2.3 Dynamic part .....	15

<b>Annex A (normative):</b>	<b>Abstract Test Suite (ATS)</b> .....	<b>16</b>
A.1	The TTCN Graphical form (TTCN.GR).....	16
A.2	The TTCN Machine Processable form (TTCN.MP) .....	16
<b>Annex B (normative):</b>	<b>Specification of PTC LT_MAC</b> .....	<b>17</b>
B.1	General requirements .....	17
B.2	Additional requirements.....	17
<b>Annex C (normative):</b>	<b>Partial PIXIT proforma for DPRS MAC FT</b> .....	<b>18</b>
C.1	Identification summary .....	18
C.2	ATS summary .....	18
C.3	Test laboratory .....	18
C.4	Client identification .....	19
C.5	SUT .....	19
C.6	Protocol layer information .....	19
C.6.1	Protocol identification .....	19
C.6.2	IUT information .....	20
<b>Annex D (normative):</b>	<b>Protocol Conformance Test Report (PCTR) Proforma for DPRS MAC FT</b> .....	<b>22</b>
D.1	Identification summary .....	22
D.1.1	Protocol conformance test report.....	22
D.1.2	IUT identification.....	22
D.1.3	Testing environment.....	22
D.1.4	Limits and reservation .....	23
D.1.5	Comments.....	23
D.2	IUT Conformance status .....	23
D.3	Static conformance summary .....	23
D.4	Dynamic conformance summary.....	23
D.5	Static conformance review report .....	24
D.6	Test campaign report.....	24
D.7	Observations.....	25
	Bibliography .....	26
	History .....	27

---

## Intellectual Property Rights

IPRs essential or potentially essential to the present document may have been declared to ETSI. The information pertaining to these essential IPRs, if any, is publicly available for **ETSI members and non-members**, and can be found in SR 000 314: "*Intellectual Property Rights (IPRs); Essential, or potentially Essential, IPRs notified to ETSI in respect of ETSI standards*", which is available from the ETSI Secretariat. Latest updates are available on the ETSI Web server (<http://www.etsi.org/ipr>).

Pursuant to the ETSI IPR Policy, no investigation, including IPR searches, has been carried out by ETSI. No guarantee can be given as to the existence of other IPRs not referenced in SR 000 314 (or the updates on the ETSI Web server) which are, or may be, or may become, essential to the present document.

---

## Foreword

This European Standard (Telecommunications series) has been produced by ETSI Project Digital Enhanced Cordless Telecommunications (DECT), and is now submitted for the Public Enquiry phase of the ETSI standards Two-step Approval Procedure.

The present document is part 3 of a multi-part EN covering the Digital Enhanced Cordless Telecommunications (DECT); DECT Packet Radio Service (DPRS) Test Case Library (TCL), as identified below:

- Part 1: "Test Suite Structure (TSS) and Test Purposes (TP) - Medium Access Control (MAC) layer";
- Part 2: "Abstract Test Suite (ATS) - Medium Access Control (MAC) layer - Portable radio Termination (PT)";
- Part 3: "Abstract Test Suite (ATS) - Medium Access Control (MAC) layer - Fixed radio Termination (FT)";**
- Part 4: "Test Suite Structure (TSS) and Test Purposes (TP) - Data Link Control (DLC) layer";
- Part 5: "Abstract Test Suite (ATS) - Data Link Control (DLC) layer - Portable radio Termination (PT)";
- Part 6: "Abstract Test Suite (ATS) - Data Link Control (DLC) layer - Fixed radio Termination (FT)";
- Part 7: "Test Suite Structure (TSS) and Test Purposes (TP) - Network (NWK) layer";
- Part 8: "Abstract Test Suite (ATS) - Network (NWK) layer - Portable radio Termination (PT)";
- Part 9: "Abstract Test Suite (ATS) - Network (NWK) layer - Fixed radio Termination (FT)".

<b>Proposed national transposition dates</b>	
Date of latest announcement of this EN (doa):	3 months after ETSI publication
Date of latest publication of new National Standard or endorsement of this EN (dop/e):	6 months after doa
Date of withdrawal of any conflicting National Standard (dow):	6 months after doa

---

# 1 Scope

The present document contains the Abstract Test Suite (ATS) specification to test the DECT Packet Radio Service (DPRS) Medium Access Control (MAC) layer at the Fixed radio Termination (FT).

The objective of this test specification is to provide a basis for conformance tests for DECT equipment giving a high probability of air interface inter-operability between different manufacturer's DECT equipment.

The ISO standard for the methodology of conformance testing (ISO/IEC 9646-1 [7] and ISO/IEC 9646-2 [8]) as well as the ETSI rules for conformance testing (ETS 300 406 [6]) are used as a basis for the test methodology.

Annex A provides the Tree and Tabular Combined Notation (TTCN) part of this ATS.

Annex B provides the specification of the parallel test component LT\_MAC.

Annex C provides the Partial Protocol Implementation Extra Information for Testing (PIXIT) Proforma of this ATS.

Annex D provides the Protocol Conformance Test Report (PCTR) Proforma of this ATS.

---

# 2 References

The following documents contain provisions which, through reference in this text, constitute provisions of the present document.

- References are either specific (identified by date of publication, edition number, version number, etc.) or non-specific.
- For a specific reference, subsequent revisions do not apply.
- For a non-specific reference, the latest version applies.
- A non-specific reference to an ETS shall also be taken to refer to later versions published as an EN with the same number.

- [1] EN 300 175-2 (1992): "Digital Enhanced Cordless Telecommunications (DECT); Common Interface (CI); Part 2: Physical Layer (PHL)".
- [2] EN 300 175-3 (1992): "Digital Enhanced Cordless Telecommunications (DECT); Common Interface (CI); Part 3: Medium Access Control (MAC) Layer".
- [3] EN 300 175-4 (1992): "Digital Enhanced Cordless Telecommunications (DECT); Common Interface (CI); Part 4: Data Link Control (DLC) Layer".
- [4] EN 300 175-6 (1992): "Digital Enhanced Cordless Telecommunications (DECT); Common Interface (CI); Part 6: Identities and Addressing".
- [5] EN 301 649: "Digital Enhanced Cordless Telecommunications (DECT); DECT Packet Radio Service (DPRS)".
- [6] ETS 300 406: "Methods for Testing and Specification (MTS); Protocol and profile conformance testing specifications; Standardization methodology".
- [7] ISO/IEC 9646-1 (1991): "Information technology - Open Systems Interconnection - Conformance testing methodology and framework - Part 1: General concepts". (See also CCITT Recommendation X.290 (1991)).
- [8] ISO/IEC 9646-2 (1991): "Information technology - Open Systems Interconnection - Conformance testing methodology and framework - Part 2: Abstract test suite specification". (See also CCITT Recommendation X.291 (1991)).

- [9] ISO/IEC 9646-3 (1991): "Information technology - Open Systems Interconnection - Conformance testing methodology and framework - Part 3: The tree and tabular combined notation". (See also CCITT Recommendation X.292 (1992)).
- [10] ISO/IEC 9646-6 (1991): "Information technology - Open Systems Interconnection - Conformance testing methodology and framework - Part 6: Protocol profile test specification".
- [11] ISO/IEC 9646-7 (1991): "Information technology - Open Systems Interconnection - Conformance testing methodology and framework - Part 7: Implementation conformance statement".
- [12] EN 300 175-8 (1992): "Digital Enhanced Cordless Telecommunications (DECT); Common Interface (CI); Part 8: Speech Coding and Transmission".

## 3 Definitions and abbreviations

### 3.1 Definitions

For the purposes of the present document, the following terms and definitions apply:

- a) the terms defined in ISO/IEC 9646-1 [7]; and
- b) the definitions in EN 300 175-3 [2].

### 3.2 Abbreviations

For the purposes of the present document, the abbreviations defined in ISO/IEC 9646-1 [7], ISO/IEC 9646-6 [10], ISO/IEC 9646-7 [11], the abbreviations defined in EN 300 175-3 [2] apply. In particular, the following definitions apply:

ASP	Abstract Service Primitive
ATM	Abstract Test Method
ATS	Abstract Test Suite
BI	Invalid Behaviour
BO	Inopportune Behaviour
BV	Valid Behaviour
CA	Capability tests
CM	Co-ordination Message
CP	Co-ordination Point
DECT	Digital Enhanced Cordless Telecommunications
DLC	Data Link Control
FP	Fixed Part
FT	Fixed radio Termination
IUT	Implementation Under Test
LT	Lower Tester
MAC	Medium Access Control
MTC	Main Test Component
PCO	Point of Control and Observation
PDU	Protocol Data Unit
PHL	Physical Layer
PICS	Protocol Implementation Conformance Statement
PP	Portable Part
PT	Portable radio Termination
PTC	Parallel Test Component
RF	Radio Frequency
RFP	Radio Fixed Part
SAP	Service Access Point

SUT	System Under Test
TP	Test Purposes
TSS	Test Suite Structure
TTCN	Tree and Tabular Combined Notation
UT	Upper Tester

## 4 Abstract Test Method (ATM)

This clause describes the ATM used to test the DECT MAC layer protocol at the Fixed radio Termination (FT).

### 4.1 Description of ATM

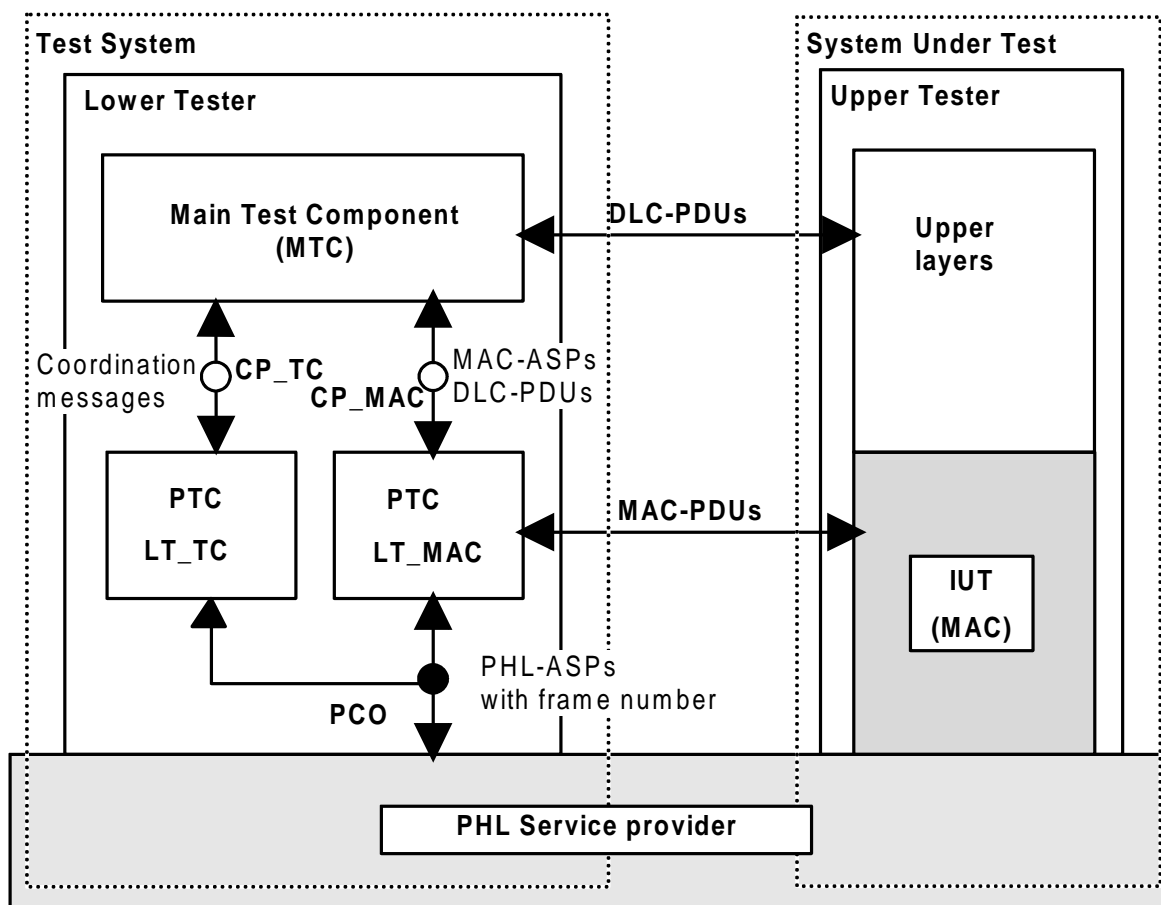

Figure 1: Remote test method, embedded variant

A single-party testing concept is used, which consists of the following abstract testing functions:

- PCO:** the Point of Control and Observation (PCO) for MAC Layer testing is located at the D-SAP between the MAC layer and the Physical layer. All test events at the PCO are specified in terms of Physical Layer - Abstract Service Primitives (PHL-ASP) (frame number parameter added);
- CP\_TC:** Co-ordination Point Test Case (CP\_TC) is located between the Main Test Component (MTC) and Parallel Test Component (PTC) LT\_TC in the test system. It is used for passing co-ordination messages between these two testing functions;
- CP\_MAC:** Co-ordination Point MAC (CP\_MAC) is located between the MTC and PTC LT\_MAC in the test system. It is equivalent to the PCO used for Data Link Control (DLC) layer testing in part 6 of the present document. All co-ordination messages at this CP are specified in terms of MAC-ASP and DLC Protocol Data Units (DLC-PDUs);



**PTC LT\_TC:** the Lower Tester Parallel Test Component LT\_TC (PTC LT\_TC) is located in the test system. It makes restricted use of the PCO by only observing the test events in both directions. It assigns preliminary verdicts (the MTC assigns the final verdict);

**NOTE:** This restricted use of the PCO is a non-ISO/IEC 9646-2 [8] application of the PCO.

**PTC LT\_MAC:** The Lower Tester Parallel Test Component LT\_MAC (PTC LT\_MAC) is located in the test system. It provides indirect control and observation of the Implementation Under Test (IUT) during test execution, via the underlying service-provider. It does not assign any verdicts;

**MTC:** The Main Test Component (MTC) is located in the test system. It is responsible for creating and terminating the PTCs, managing the co-ordination points CP\_TC and CP\_MAC, and computation of the final test case verdict;

**Upper layers:** No explicit Upper Tester (UT) exists in the test system. However, the System Under Test (SUT) (upper layers) needs to carry out some UT functions to achieve some effects of test co-ordination procedures.

The primitives used at the PCO (physical Service Access Point (SAP) - DSAP) are defined according to EN 300 175-2 [1] clause 7 and associated subclauses.

The co-ordination messages used at CP\_MAC co-ordination point are abstract primitives including protocol data units and frames. The abstract primitives (MAC ASP) are defined according to EN 300 175-3 [2] clause 8 and associated subclauses. Two abstract primitives for starting and stopping the synchronization between the main test component and the parallel test component LT\_MAC are added for the needs of the tester. The protocol data units (DLC C-plane PDUs) are defined according to EN 300 175-4 [3] clause 7 and associated subclauses. The frames (DLC U-plane frames) are defined according to EN 300 175-4 [3] clause 12 and associated subclauses.

## 4.2 Test strategy

The ATM defined in subclause 4.1 requires the use of concurrent TTCN, which is specified in Amendment 1 of ISO/IEC 9646-3 [9]. The parallel test components PTC\_TC and PTC\_MAC are, however, seen as two independent entities. This means that there is no communication or synchronization between the two PTCs during the test.

PTC\_TC is specified in TTCN (see annex A). Since PTC\_TC is only observing at the PCO, this ATS does not contain any send statements. Once the TP is fulfilled, the PTC\_TC terminates, i.e. there are no post ambles, unless required by the TP. No explicit co-ordination messages is exchanged at CP\_TC. To simplify the TTCN test cases, the underlying service provider has been assigned the task of frame numbering. Consequently, a frame parameter has been added to some of the PHL-ASP.

The Main Test Component (MTC) creates the two PTCs (using CREATE operation), stimulates the PTC\_MAC (using MAC ASP at CP\_MAC) and then waits for the two PTCs to terminate (using the DONE event). The final verdict is computed as follows:

- a PASS is assigned if PTC\_TC returns a PASS verdict and the expected event is received from PTC\_MAC at CP\_MAC;
- a FAIL verdict is assigned if PTC\_TC returns a FAIL verdict independently of what is received from PTC\_MAC at CP\_MAC;
- an INCONC verdict is assigned if PTC\_TC returns an INCONC verdict and the expected event is received from PTC\_MAC at CP\_MAC, or returns a PASS verdict and an unexpected event is received from PTC\_MAC at CP\_MAC.

## 5 Untestable Test Purposes (TP)

This clause gives a list of TP which are not implemented in the ATS for PTC LT\_TC (see annex A) due to the chosen ATM or other restrictions.

**Table 1: Untestable TP**

Test purpose	Reason

## 6 ATS conventions (only applicable for PTC LT\_TC)

The ATS conventions are intended to give a better understanding of the ATS but they also describe the conventions made for the development of the ATS. These conventions shall be considered during any later maintenance or further development of the ATS.

The ATS conventions contain two clauses, the naming conventions and the implementation conventions. The naming conventions describe the structure of the naming of all ATS elements. The implementation conventions describe the functional structure of the ATS.

To define the ATS, the guidelines of the document ETS 300 406 [6] was considered.

### 6.1 Naming conventions

#### 6.1.1 Declarations part

This subclause describes the naming conventions chosen for the elements of the ATS declarations part.

##### 6.1.1.1 General

The following general rules apply for the name giving in the declarations part. All type definitions (simple type definitions, structured type definitions, ASP type definitions and PDU type definitions) shall be written in uppercase.

All element names (structured type definition), parameter names (ASP type definition) and field names (PDU type definition) shall be written in lowercase.

Predefined types (e.g. BITSTRING [12]) are never used in structured type definitions, ASP type definitions or PDU type definitions. Simple types are used instead.

All declarations in the test suite are listed in alphabetical order. A different order of listing should be used for only maintenance reasons.

##### 6.1.1.2 Test suite operations definition

The test suite operation identifiers are composed of substrings in lowercase letters, except for standard prefix "TSO\_". Each substring is separated by an underscore character ("\_").

EXAMPLE: TSO\_substring.

### 6.1.1.3 Test suite parameter declarations

The test suite parameter identifiers are composed of substrings in lowercase letters, except for the standard prefix "TSP\_". Each substring is separated by an underscore character ("\_").

EXAMPLE 1: TSP\_t\_wait.

If the test suite parameter references a Protocol Implementation Conformance Statement (PICS) item, the letter "C" is added to the standard prefix.

EXAMPLE 2: TSPC\_extended\_rf\_carriers.

If the test suite parameter references a PIXIT item, the letter "X" is added to the standard prefix.

EXAMPLE 3: TSPX\_pmid.

Complete names as defined in the specifications are used.

### 6.1.1.4 Test case selection expression definition

The test case selection expression identifiers are composed of substrings in lowercase letters, beginning with the prefix "TCS\_". Each substring is separated by an underscore character ("\_").

### 6.1.1.5 Test suite constant declarations

The test suite constant identifiers are composed of substrings in lowercase letters, except for the prefix "TSC\_". Each substring is separated by an underscore character ("\_").

If the test suite constant represents a system parameter, the complete name defined in the protocol standard is used.

EXAMPLE: TSC\_n200.

### 6.1.1.6 Test suite variable declarations

The test suite variable identifiers are composed of substrings in lowercase letters, except for the prefix "TSV\_". Each substring is separated by an underscore character ("\_").

Complete names as defined in the protocol standard are used.

### 6.1.1.7 Test case variable declarations

The test case variable identifiers are composed of substrings in lowercase letters, except for the prefix "TCV\_". Each substring is separated by an underscore character ("\_").

Complete names as defined in the protocol standard are used.

### 6.1.1.8 Timer declarations

Two types of timers can be identified:

1) standardized:

- those defined in the protocol standard, e.g. T201. They use exactly the same name as in the standard.

As there is a tolerance margin accepted for these timers, three values are needed:

- the maximum value allowed, which will use the suffix "\_max";
- the minimum value allowed, which will use the suffix "\_min";
- the value actually implemented, with no suffix;

EXAMPLE 1: T201\_max, T201\_min, and T201.

2) not standardized:

- those not defined in the protocol standard, i.e. for execution use, e.g. a timer waiting for a response. These timers begin with the prefix "T\_", followed by a string in lowercase letters.

EXAMPLE 2: T\_resp represents a timer for controlling the response time of the IUT.

### 6.1.1.9 ASP type definitions

The general conventions in subclause 6.1.1.1 applies.

The identifier of an ASP type uses the same name as the name defined in the protocol standard.

EXAMPLE: PL\_TX\_REQ for an ASP containing a MAC layer PDU to the peer MAC layer (the IUT).

### 6.1.1.10 PDU type definitions

The general conventions in subclause 6.1.1.1 applies.

The PDU type identifier shall identify the related structure or type as defined in the protocol standard.

EXAMPLE: A\_MT\_BASIC\_CONNECTION\_CONTROL.

### 6.1.1.11 CM type definitions

The CM types are defined as the ASP types without sub-fields.

### 6.1.1.12 Alias definitions

Alias definitions are not used.

## 6.1.2 Constraints part

This subclause describes the naming conventions chosen for the elements of the ATS constraints part.

### 6.1.2.1 General

Constraints shall be written with the first letter in uppercase, and the rest in lowercase.

The first part of the constraint declaration identifier name is equivalent to the corresponding type identifier used in the declaration part. The second part of the name describes the content of this constraint.

EXAMPLE: Declaration part: HEADER\_FIELD.  
Constraint part: Header\_field\_nt\_no\_b.

### 6.1.3 Dynamic part

This subclause describes the naming conventions used for the elements of the ATS dynamic part.

#### 6.1.3.1 General

All test cases shall be listed in the order in which they appear in the Test Suite Structure (TSS) and TP document.

#### 6.1.3.2 Test Case (TC) identifier

The identifier of the test case is built in the same way as for the test purpose described in part 1 of the present document, with the exception that "TP" is replaced by "TC\_FT" ("FT" for Fixed radio Termination). The identifier of a TC is built according to table 2.

**Table 2: TC naming convention**

Identifier:	DTC_FT_<fm>_<x>_<nn>		
	<fm> = functional module	DB	Down link Broadcast
		PG	Paging services
		NB	Non Continuous Broadcast
		BS	Bearer setup
		CM	Connection modification
		BH	Bearer handover
		BR	Bearer release
		CH	Connection handover
		DT	C-plane services
		UP	U-plane services
		EN	Encryption
		LM	Layer Management
	<x> = Type of testing	CA	Capability Tests
		BV	Valid Behaviour Tests
		BI	Invalid Behaviour Tests
	<nn> = sequential number	(00-99)	Test purpose Number

EXAMPLE: TP identifier: TP/BS/CA-00.  
TC identifier: DTC\_FT\_BS\_CA\_00.

### 6.1.3.3 Test step identifier

The test step identifier is built of substrings in lowercase letters, preceded by a string of uppercase letters. The substrings are joined by underscore characters. The first substring indicates the main function of the test step; e.g. PR for preamble, PO for postamble, LTS for local tree and STP for general test step. The second substring indicates the purpose of the step.

EXAMPLE: PO\_release\_bearer.

### 6.1.3.4 Default identifier

The default identifiers begin with the prefix "DF\_", followed by a string in lowercase letters.

### 6.1.3.5 Label identifier

The identifiers in the label column is built according to table 3:

**Table 3: Naming convention for verdict assignment identifier**

Identifier:	<Table><nn>		
	<Table> = type of table	TB	Test Body
		CS	Check State test step
		DF	DeFault
		PO	POstamble
		PR	PReamble
		TS	TestStep
	<nn> = sequential number	(00-99)	Label number

### 6.1.3.6 ATS abbreviations

These abbreviations are used to shorten identifier names:

addr	address
ack	acknowledgement
bear	bearer
cap	capability
cfm	confirm
chn	channel
con	connection
ctrl	control
est	establish
ext	extension
id	identification
ind	indication
info	information
max	maximum
min	minimum
par	parameter
prop	proprietary
rel	release
req	request
rsp	response
std	standard
sys	system

## 6.2 Implementation conventions

### 6.2.1 Declaration part

The comment line of single element TTCN tables (e.g. test suite constants) is used to give a reference where the format and content of the element is described in the relevant protocol standards. Any particularity of the element format or content is described in the comment line.

The comment line in the header of multi element TTCN tables (e.g. ASP) is used to reference to the protocol standard.

The detailed comments are used to describe any peculiarity of the table.

In the ASP, PDU, and CM declarations, the comments column is used to identify if a parameter (in ASP) or field (in PDUs) is mandatory or optional:

- M: mandatory;
- O: optional.

In the ASP and PDU declarations the comments column is further used to give information about the parameter/field value, in particular if the parameter/field contains a fixed spare value.

### 6.2.2 Constraint part

The ASPs and PDUs are defined in a way that all relevant parameters/fields are parameterized. That improves the transparency of the constraints in the dynamic part, as all values which are relevant for the test are always present.

Generally no modified constraints are used. This allows an easier reuse and adaptation of constraints if they are reused in other test specifications.

The Comment line of a constraint always contains a reference to the relevant protocol standard.

The detailed comments footer is used to describe any particularity of the table.

### 6.2.3 Dynamic part

All events which are defined as a conformance requirement by the TP, causes a preliminary verdict PASS if the requirement is met.

All invalid events are handled in the default tree. Only FAIL or INCONC verdicts are assigned in the default tree.

The preamble, the test body and the postamble have different defaults, which allows a specific verdict handling, e.g. only INCONC verdicts are assigned in the preamble.

All verdict assignments are labelled. According to ISO/IEC 9646-3 [9], annex E, clause E.2, labels should be written to the conformance log. This allows, for example, to identify where the test failed. To allow an exact identification of the table in which the verdict was assigned, the convention described in subclause 6.1.3.5 is applied.

To avoid deadlocks, the Parallel Test Components (PTC) LT\_TC and LT\_MAC shall always terminate.

TP which are listed in the untestable TP list in clause 5 are not considered in the ATS, thus these TC identifiers are missing in the ATS and the numbering of the TCs is not always continuous.

---

## Annex A (normative): Abstract Test Suite (ATS)

This ATS has been produced using the Tree and Tabular Combined Notation (TTCN) according to ISO/IEC 9646-3 [9].

The ATS was developed on a separate TTCN software tool and therefore the TTCN tables are not completely referenced in the table of contents. The ATS itself contains a test suite overview part which provides additional information and references.

---

### A.1 The TTCN Graphical form (TTCN.GR)

The TTCN.GR representation of this ATS is contained in an Adobe Portable Document Format™ file (14690301.PDF contained in archive dlor001c.ZIP) which accompanies the present document.

---

### A.2 The TTCN Machine Processable form (TTCN.MP)

The TTCN.MP representation corresponding to this ATS is contained in an ASCII file (14690301.MP contained in archive dlor001c.ZIP) which accompanies the present document.



## Annex B (normative): Specification of PTC LT\_MAC

### B.1 General requirements

The PTC LT\_MAC (MAC emulation) shall, as a minimum, fulfil all requirements needed for implementation of all the Data Services Profile.

### B.2 Additional requirements

A number of commands have been defined to control the behaviour of PTC LT\_MAC (the MAC emulation). In annex A, these are implemented as a co-ordination message with a parameter to specify the required action. The test system shall support the actions specified in table B.1.

**Table B.1: Actions to be supported by the test system**

Action	Ref. to EN 300 175-3 [2]	Requirement
TSC_action2	6.2.5.1	Generate A field CRC error in NT message.
TSC_action3	EN 300 175-2 [1]: 4.8	Pass to physical layer a request for generating Z field error
TSC_action4	11.5.1	Generate an incorrect message for RFPI handshake. Change the RFPI transmitted by the Lower Tester on all bearers to the IUT by inverting bit a16 to a23.
TSC_action5	10.8.1.1	Acknowledge received Cs segment only after three receipt.
TSC_action17	10.5.1 - 10.6.2	Initiate and perform an intracell bearer handover procedure.
TSC_action18	10.5.1 - 10.6.2	Initiate and perform an intercell bearer handover procedure.
TSC_start	11.3.2	Start test case synchronization.
TSC_stop	11.5.1	Stop test case synchronization.
NOTE: These actions are defined as test suite constants in the ATS (see annex A).		

---

## Annex C (normative): Partial PIXIT proforma for DPRS MAC FT

Notwithstanding the provisions of the copyright clause related to the text of the present document, ETSI grants that users of the present document may freely reproduce the PIXIT proforma in this annex so that it can be used for its intended purposes and may further publish the completed PIXIT.

The PIXIT Proforma is based on ISO/IEC 9646-6 [10]. Any additional information needed can be found in this international standard document.

---

### C.1 Identification summary

**Table C.1**

PIXIT Number:	
Test Laboratory Name:	
Date of Issue:	
Issued to:	

---

### C.2 ATS summary

**Table C.2**

Protocol Specification:	EN 301 649 [5]
Protocol to be tested:	
ATS Specification:	EN 301 469-3
Abstract Test Method:	EN 301 469-3 clause 4

---

### C.3 Test laboratory

**Table C.3**

Test Laboratory Identification:	
Test Laboratory Manager:	
Means of Testing:	
SAP Address:	

---

## C.4 Client identification

Table C.4

Client Identification:	
Client Test manager:	
Test Facilities required:	

---

## C.5 SUT

Table C.5

Name:	
Version:	
SCS Number:	
Machine configuration:	
Operating System Identification:	
IUT Identification:	
PICS Reference for IUT:	
Limitations of the SUT:	
Environmental Conditions:	

---

## C.6 Protocol layer information

### C.6.1 Protocol identification

Table C.6

Name:	DECT - MAC layer EN 301 649 [5]
Version:	
PICS References:	

## C.6.2 IUT information

**Table C.7: Addresses**

Item	Parameter	Parameter Type	Explanation	Value
1	TSPX_pmid	B_20 - (Bitstring[9])	PMID for RFP	
2	TSPX_rfp1	B_40 - (Bitstring[40])	RFPI for RFP number 1 (EN 300 175-6 [4])	
3	TSPX_rfp1_invalid	B_40 - (Bitstring[40])	derived from item 2 RFPI for RFP number 1 with bit a16 to a23 inverted (EN 300 175-6 [4])	
4	TSPX_rfp2	B_40 - (Bitstring[40])	RFPI for RFP number 2 (EN 300 175-6 [4])	

**Table C.8: Parameter values**

Item	Parameter	Parameter Type	Explanation	Value
1	TSPX_t_implicit_send	INT_0_99 - INTEGER (0..99)	Max. time to wait after request for invocation of an implicit send event (In second).	

**Table C.9: Procedural information**

Item	Parameter	Parameter Type	Explanation	Value
1	TSPX_blind_slot	BOOLEAN	TRUE for IUT that have blind slot.	TRUE FALSE
2	TSPX_extended_rf	BOOLEAN	Does the IUT support extended RF carrier.	TRUE FALSE
3	TSPX_sari	BOOLEAN	Does the IUT support Secondary Access Rights Identity (SARI) list.	TRUE FALSE
4	TSPX_intercell_ha ndover	BOOLEAN	Does the IUT support intercell handover.	TRUE FALSE
5	TSPX_intracell_ha ndover	BOOLEAN	Does the IUT support intracell handover.	TRUE FALSE
6	TSPX_bearer_han dover	BOOLEAN	Does the IUT support bearer handover within the whole FT?	TRUE FALSE

Table C.10: Implicit send events

Item	PIXIT (see NOTE)	Parameter Type	Indication how the implicit send event can be invoked
1	TSPX_invoke_short_page	Implicit Send	Indicate in the following lines the procedure to force the IUT to transmit a paging message in short page format. ..... ..... ..... .....
2	TSPX_invoke_zero_page	Implicit Send	Indicate in the following lines the procedure to force the IUT to transmit a paging message in zero page format. ..... ..... ..... .....
3	TSPX_invoke_sari_message	Implicit Send	Indicate in the following lines the procedure to force the IUT to transmit the NT message with E bit set (A SARI is introduced). ..... ..... ..... .....
NOTE: The PIXIT names are related to the test steps where the Implicit send events are handled, e.g. the PIXIT TSPX_invoke_abnormal_release is related to the test step STP_invoke_abnormal_release.			

## Annex D (normative): Protocol Conformance Test Report (PCTR) Proforma for DPRS MAC FT

Notwithstanding the provisions of the copyright clause related to the text of the present document, ETSI grants that users of the present document may freely reproduce the PCTR proforma in this annex so that it can be used for its intended purposes and may further publish the completed PCTR.

The PCTR proforma is based on ISO/IEC 9646-6 [10]. Any additional information needed can be found in this document.

### D.1 Identification summary

#### D.1.1 Protocol conformance test report

**Table D.1**

PCTR Number:	
PCTR Date:	
Corresponding SCTR Number:	
Corresponding SCTR Date:	
Test Laboratory Identification:	
Test Laboratory Manager:	
Signature:	

#### D.1.2 IUT identification

**Table D.2**

Name:	
Version:	
Protocol specification:	
PICS:	
Previous PCTR if any:	

#### D.1.3 Testing environment

**Table D.3**

PIXIT Number:	
ATS Specification:	
Abstract Test Method:	Remote test method, Embedded variant with no UT
Means of Testing identification:	
Date of testing:	
Conformance Log reference(s):	
Retention Date for Log reference(s):	

## D.1.4 Limits and reservation

Additional information relevant to the technical contents or further use of the test report, or the rights and obligations of the test laboratory and the client, may be given here. Such information may include restriction on the publication of the report.

.....

.....

.....

.....

.....

.....

## D.1.5 Comments

Additional comments may be given by either the client or the test laboratory on any of the contents of the PCTR, for example, to note disagreement between the two parties.

.....

.....

.....

.....

.....

---

## D.2 IUT Conformance status

This IUT has or has not been shown by conformance assessment to be non conforming to the specified protocol specification.

*Strike the appropriate words in this sentence. If the PICS for this IUT is consistent with the static conformance requirements (as specified in clause D.3 in this report) and there are no "FAIL" verdicts to be recorded (in clause D.6 in this report) strike the words "has or",. otherwise strike the words "or has not".*

---

## D.3 Static conformance summary

The PICS for this IUT is or is not consistent with the static conformance requirements in the specified protocol.

*Strike the appropriate words in this sentence.*

---

## D.4 Dynamic conformance summary

The test campaign did or did not reveal errors in the IUT.

*Strike the appropriate words in this sentence. If there are no "FAIL" verdicts to be recorded (in clause D.6 of this report) strike the words "did or" otherwise strike the words "or did not".*

Summary of the results of groups of test:

.....

.....

.....

.....

.....

.....

## D.5 Static conformance review report

If clause D.3 indicates non-conformance, this subclause itemizes the mismatches between the PICS and the static conformance requirements of the specified protocol specification.

.....

.....

.....

.....

.....

.....

.....

.....

.....

## D.6 Test campaign report

Table D.4

ATS Reference	Selected?	Run?	Verdict	Observations (Reference to any observations made in clause 7)
DTC-FT-DB-CA-00	Yes/No	Yes/No		
DTC-FT-DB-CA-01	Yes/No	Yes/No		
DTC-FT-DB-CA-02	Yes/No	Yes/No		
DTC-FT-DB-CA-03	Yes/No	Yes/No		
DTC-FT-DB-CA-04	Yes/No	Yes/No		
DTC-FT-DB-CA-05	Yes/No	Yes/No		
DTC-FT-DB-CA-06	Yes/No	Yes/No		
DTC-FT-DB-CA-07	Yes/No	Yes/No		
DTC-FT-DB-CA-51	Yes/No	Yes/No		
DTC-FT-DB-CA-52	Yes/No	Yes/No		
DTC-FT-DB-BV-03	Yes/No	Yes/No		
DTC-FT-NB-CA-data00	Yes/No	Yes/No		
DTC-FT-NB-CA-data01	Yes/No	Yes/No		
DTC-FT-PG-CA-00	Yes/No	Yes/No		
DTC-FT-PG-CA-01	Yes/No	Yes/No		
DTC-FT-PG-CA-data00	Yes/No	Yes/No		
DTC-FT-PG-CA-data01	Yes/No	Yes/No		
DTC-FT-PG-BV-01	Yes/No	Yes/No		
DTC-FT-PG-BV-data00	Yes/No	Yes/No		
DTC-FT-PG-BV-data01	Yes/No	Yes/No		
DTC-FT-PG-BV-data02	Yes/No	Yes/No		
DTC-FT-BS-CA-data00	Yes/No	Yes/No		
DTC-FT-BS-CA-data01	Yes/No	Yes/No		
DTC-FT-BS-CA-data02	Yes/No	Yes/No		
DTC-FT-BS-CA-data03	Yes/No	Yes/No		
DTC-FT-BS-CA-data04	Yes/No	Yes/No		
DTC-FT-CM-CA-data00	Yes/No	Yes/No		
DTC-FT-CM-CA-data01	Yes/No	Yes/No		
DTC-FT-BR-CA-data00	Yes/No	Yes/No		
DTC-FT-BR-CA-data01	Yes/No	Yes/No		
DTC-FT-BR-CA-data02	Yes/No	Yes/No		
DTC-FT-BR-CA-data03	Yes/No	Yes/No		
DTC-FT-BH-CA-01	Yes/No	Yes/No		
DTC-FT-DT-CA-00	Yes/No	Yes/No		
DTC-FT-DT-CA-01	Yes/No	Yes/No		
DTC-FT-DT-CA-02	Yes/No	Yes/No		
DTC-FT-DT-CA-data00	Yes/No	Yes/No		





---

## Bibliography

The following material, though not specifically referenced in the body of the present document (or not publicly available), gives supporting information.

EN 300 175-1 (1992): "Digital Enhanced Cordless Telecommunications (DECT); Common Interface (CI); Part 1: Overview".

EN 300 175-5 (1992): "Digital Enhanced Cordless Telecommunications (DECT); Common Interface (CI); Part 5: Network (NWK) Layer".

EN 300 175-7 (1992): "Digital Enhanced Cordless Telecommunications (DECT); Common Interface (CI); Part 7: Security Features".

ETS 300 435: "Digital Enhanced Cordless Telecommunications (DECT); Data Services Profile (DSP); Base standard including interworking to connectionless networks (service types A and B, class 1)".

ETS 300 651: "Digital Enhanced Cordless Telecommunications (DECT); Data Services Profile (DSP); Generic data link service (service type C, class 2)".

ETS 300 699: "Digital Enhanced Cordless Telecommunications (DECT); Data Services Profile (DSP); Generic data link service for closed user groups (service type C, class 1)".

ETS 300 701: "Digital Enhanced Cordless Telecommunications (DECT); Data Services Profile (DSP); Generic frame relay service with mobility (service types A and B, class 2)".

ETS 300 755: "Digital Enhanced Cordless Telecommunications (DECT); Data Services Profile (DSP); Multimedia Messaging Service (MMS) with specific provision for facsimile services (service type F, class 2)".

ETS 300 757: "Digital Enhanced Cordless Telecommunications (DECT); Data Services Profile (DSP); Low rate messaging service (service type E, class 2)".

EN 301 240: "Digital Enhanced Cordless Telecommunications (DECT); Data Services Profile (DSP); Point-to-Point Protocol (PPP) interworking for internet access and general multi-protocol datagram transport".

---

## History

<b>Document history</b>			
V0.0.2	November 1999	Public Enquiry	PE 200012: 1999-11-24 to 2000-03-24