

Final draft **ETSI EN 301 469-1** V0.0.3 (2000-08)

European Standard (Telecommunications series)

**Digital Enhanced Cordless Telecommunications (DECT);
DECT Packet Radio Service (DPRS) Test Case Library (TCL);
Part 1: Test Suite Structure (TSS) and Test Purposes (TP)
- Medium Access Control (MAC) layer**



Reference

DEN/DECT-040047-1

KeywordsData, DECT, DPRS, MAC, radio, testing,
TSS&TP**ETSI**

650 Route des Lucioles
F-06921 Sophia Antipolis Cedex - FRANCE

Tel.: +33 4 92 94 42 00 Fax: +33 4 93 65 47 16

Siret N° 348 623 562 00017 - NAF 742 C
Association à but non lucratif enregistrée à la
Sous-Préfecture de Grasse (06) N° 7803/88

Important notice

Individual copies of the present document can be downloaded from:

<http://www.etsi.org>

The present document may be made available in more than one electronic version or in print. In any case of existing or perceived difference in contents between such versions, the reference version is the Portable Document Format (PDF). In case of dispute, the reference shall be the printing on ETSI printers of the PDF version kept on a specific network drive within ETSI Secretariat.

Users of the present document should be aware that the document may be subject to revision or change of status. Information on the current status of this and other ETSI documents is available at <http://www.etsi.org/tb/status/>

If you find errors in the present document, send your comment to:
editor@etsi.fr

Copyright Notification

No part may be reproduced except as authorized by written permission.
The copyright and the foregoing restriction extend to reproduction in all media.

© European Telecommunications Standards Institute 2000.
All rights reserved.

Contents

| | |
|--|----|
| Intellectual Property Rights | 6 |
| Foreword..... | 6 |
| 1 Scope | 7 |
| 2 References | 7 |
| 3 Definitions and abbreviations..... | 8 |
| 3.1 Definitions | 8 |
| 3.2 Abbreviations | 8 |
| 4 Test suite structure | 9 |
| 4.1 Overview | 9 |
| 4.2 Test suite structure (TSS)..... | 9 |
| 4.3 Test groups | 10 |
| 4.3.1 Protocol groups..... | 10 |
| 4.3.1.1 General services | 10 |
| 4.3.1.2 Broadcast services..... | 10 |
| 4.3.1.3 Advanced connection services | 10 |
| 4.3.1.4 C-plane services | 10 |
| 4.3.1.5 U-plane services..... | 10 |
| 4.3.1.6 Encryption..... | 10 |
| 4.3.1.7 Layer management procedures..... | 10 |
| 4.3.2 Main test groups | 10 |
| 4.3.2.1 Capability (CA) tests..... | 10 |
| 4.3.2.2 Valid Behaviour (BV) tests..... | 11 |
| 4.3.2.3 Invalid Behaviour (BI) tests | 11 |
| 5 Test Purposes (TP) | 11 |
| 5.1 Introduction | 11 |
| 5.1.1 TP definition conventions..... | 11 |
| 5.1.2 TP naming conventions | 11 |
| 5.1.3 Sources of TP definitions..... | 12 |
| 5.2 Test purposes for FT part | 12 |
| 5.2.1 TP presentation | 12 |
| 5.2.2 General services..... | 12 |
| 5.2.2.1 MAC service and procedure concerned | 12 |
| 5.2.2.2 Test purposes..... | 12 |
| 5.2.3 Broadcast services..... | 12 |
| 5.2.3.1 Downlink broadcast | 12 |
| 5.2.3.1.1 MAC service and procedure concerned..... | 12 |
| 5.2.3.1.2 CA test purposes..... | 13 |
| 5.2.3.1.3 BV test purposes..... | 14 |
| 5.2.3.2 Non continuous broadcast..... | 14 |
| 5.2.3.2.1 MAC service and procedure concerned..... | 14 |
| 5.2.3.2.2 CA test purposes..... | 14 |
| 5.2.3.3 Paging services..... | 14 |
| 5.2.3.3.1 MAC service and procedure concerned..... | 14 |
| 5.2.3.3.2 CA test purposes..... | 15 |
| 5.2.3.3.3 BV test purposes..... | 15 |
| 5.2.4 Advanced connection..... | 16 |
| 5.2.4.1 Bearer setup procedures | 16 |
| 5.2.4.1.1 MAC service and procedure concerned..... | 16 |
| 5.2.4.1.2 CA test purposes..... | 16 |
| 5.2.4.2 Connection modification procedures | 17 |
| 5.2.4.2.1 MAC service and procedure concerned..... | 17 |
| 5.2.4.2.2 CA test purposes..... | 17 |
| 5.2.4.3 Bearer release procedures | 17 |

| | | |
|-----------|--|----|
| 5.2.4.3.1 | MAC service and procedure concerned..... | 17 |
| 5.2.4.3.2 | CA test purposes..... | 18 |
| 5.2.4.4 | Bearer handover procedures..... | 18 |
| 5.2.4.4.1 | MAC service and procedure concerned..... | 18 |
| 5.2.4.4.2 | CA test purposes..... | 18 |
| 5.2.4.5 | Connection handover procedures..... | 19 |
| 5.2.4.5.1 | MAC service and procedure concerned..... | 19 |
| 5.2.4.5.2 | Test purposes..... | 19 |
| 5.2.5 | C-plane higher layer signalling..... | 19 |
| 5.2.5.1 | MAC service and procedure concerned..... | 19 |
| 5.2.5.2 | CA test purposes..... | 20 |
| 5.2.6 | U-plane services..... | 20 |
| 5.2.6.1 | MAC service and procedure concerned..... | 21 |
| 5.2.6.2 | CA test purposes..... | 21 |
| 5.2.6.3 | BI test purposes..... | 22 |
| 5.2.7 | Encryption..... | 22 |
| 5.2.7.1 | MAC service and procedure concerned..... | 22 |
| 5.2.7.2 | CA test purposes..... | 22 |
| 5.2.8 | MAC layer management..... | 23 |
| 5.2.8.1 | MAC service and procedure concerned..... | 23 |
| 5.2.8.2 | CA test purposes..... | 23 |
| 5.3 | Test purposes for PT part..... | 23 |
| 5.3.1 | TP presentation..... | 23 |
| 5.3.2 | General services..... | 23 |
| 5.3.2.1 | MAC service and procedure concerned..... | 23 |
| 5.3.2.2 | Test purposes..... | 23 |
| 5.3.3 | Broadcast services..... | 24 |
| 5.3.3.1 | Downlink broadcast..... | 24 |
| 5.3.3.1.1 | MAC service and procedure concerned..... | 24 |
| 5.3.3.1.2 | CA test purposes..... | 24 |
| 5.3.3.1.3 | BV test purposes..... | 24 |
| 5.3.3.2 | Non continuous broadcast..... | 24 |
| 5.3.3.2.1 | MAC service and procedure concerned..... | 25 |
| 5.3.3.2.2 | Test purposes..... | 25 |
| 5.3.3.3 | Paging services..... | 25 |
| 5.3.3.3.1 | MAC service and procedure concerned..... | 25 |
| 5.3.3.3.2 | CA test purposes..... | 25 |
| 5.3.3.3.3 | BV test purposes..... | 26 |
| 5.3.4 | Advanced connection..... | 26 |
| 5.3.4.1 | Bearer setup procedures..... | 26 |
| 5.3.4.1.1 | MAC service and procedure concerned..... | 26 |
| 5.3.4.1.2 | CA test purposes..... | 27 |
| 5.3.4.2 | Connection modification procedures..... | 27 |
| 5.3.4.2.1 | MAC service and procedure concerned..... | 27 |
| 5.3.4.2.2 | CA test purposes..... | 27 |
| 5.3.4.3 | Bearer release procedures..... | 28 |
| 5.3.4.3.1 | MAC service and procedure concerned..... | 28 |
| 5.3.4.3.2 | CA test purposes..... | 28 |
| 5.3.4.4 | Bearer handover procedures..... | 29 |
| 5.3.4.4.1 | MAC service and procedure concerned..... | 29 |
| 5.3.4.4.2 | CA test purposes..... | 29 |
| 5.3.4.5 | Connection handover procedures..... | 29 |
| 5.3.4.5.1 | MAC service and procedure concerned..... | 29 |
| 5.3.4.5.2 | Test purposes..... | 29 |
| 5.3.5 | C-plane higher layer signalling..... | 29 |
| 5.3.5.1 | MAC service and procedure concerned..... | 29 |
| 5.3.5.2 | CA test purposes..... | 30 |
| 5.3.6 | U-plane services..... | 30 |
| 5.3.6.1 | MAC service and procedure concerned..... | 31 |
| 5.3.6.2 | CA test purposes..... | 31 |
| 5.3.6.3 | BI test purposes..... | 31 |
| 5.3.7 | Encryption..... | 32 |

| | | |
|--------------------|---|----|
| 5.3.7.1 | MAC service and procedure concerned | 32 |
| 5.3.7.2 | CA test purposes | 32 |
| 5.3.8 | MAC layer management | 32 |
| 5.3.8.1 | MAC service and procedure concerned | 33 |
| 5.3.8.2 | CA test purposes | 33 |
| Bibliography | | 34 |
| History | | 35 |

Intellectual Property Rights

IPRs essential or potentially essential to the present document may have been declared to ETSI. The information pertaining to these essential IPRs, if any, is publicly available for **ETSI members and non-members**, and can be found in ETSI SR 000 314: "*Intellectual Property Rights (IPRs); Essential, or potentially Essential, IPRs notified to ETSI in respect of ETSI standards*", which is available from the ETSI Secretariat. Latest updates are available on the ETSI Web server (<http://www.etsi.org/ipr>).

Pursuant to the ETSI IPR Policy, no investigation, including IPR searches, has been carried out by ETSI. No guarantee can be given as to the existence of other IPRs not referenced in ETSI SR 000 314 (or the updates on the ETSI Web server) which are, or may be, or may become, essential to the present document.

Foreword

This European Standard (Telecommunications series) has been produced by ETSI Project Digital Enhanced Cordless Telecommunications (DECT), and is now submitted for the Voting phase of the ETSI standards Two-step Approval Procedure.

The present document is part 1 of a multi-part deliverable covering the Digital Enhanced Cordless Telecommunications (DECT); DECT Packet Radio Service (DPRS) Test Case Library (TCL), as identified below:

- Part 1:** "Test Suite Structure (TSS) and Test Purposes (TP) - Medium Access Control (MAC) layer";
- Part 2: "Abstract Test Suite (ATS) - Medium Access Control (MAC) layer - Portable radio Termination (PT)";
- Part 3: "Abstract Test Suite (ATS) - Medium Access Control (MAC) layer - Fixed radio Termination (FT)";
- Part 4: "Test Suite Structure (TSS) and Test Purposes (TP) - Data Link Control (DLC) layer";
- Part 5: "Abstract Test Suite (ATS) - Data Link Control (DLC) layer - Portable radio Termination (PT)";
- Part 6: "Abstract Test Suite (ATS) - Data Link Control (DLC) layer - Fixed radio Termination (FT)";
- Part 7: "Test Suite Structure (TSS) and Test Purposes (TP) - Network (NWK) layer";
- Part 8: "Abstract Test Suite (ATS) - Network (NWK) layer - Portable radio Termination (PT)";
- Part 9: "Abstract Test Suite (ATS) - Network (NWK) layer - Fixed radio Termination (FT)".

| Proposed national transposition dates | |
|--|---------------------------------|
| Date of latest announcement of this EN (doa): | 3 months after ETSI publication |
| Date of latest publication of new National Standard or endorsement of this EN (dop/e): | 6 months after doa |
| Date of withdrawal of any conflicting National Standard (dow): | 6 months after doa |

1 Scope

The present document contains the Test Suite Structure (TSS) and Test Purposes (TP) to test the DECT Packet Radio Service (DPRS) Medium Access Control (MAC) layer.

The objective of this test specification is to provide a basis for conformance tests for DECT equipment giving a high probability of air interface inter-operability between different manufacturers' DECT equipment.

The ISO standard for the methodology of conformance testing (ISO/IEC 9646-1 [6] and ISO/IEC 9646-2 [7]) as well as the ETSI rules for conformance testing (ETS 300 406 [5]) are used as a basis for the test methodology.

2 References

The following documents contain provisions which, through reference in this text, constitute provisions of the present document.

- References are either specific (identified by date of publication, edition number, version number, etc.) or non-specific.
- For a specific reference, subsequent revisions do not apply.
- For a non-specific reference, the latest version applies.
- A non-specific reference to an ETS shall also be taken to refer to later versions published as an EN with the same number.

- [1] ETSI EN 300 175-3: "Digital Enhanced Cordless Telecommunications (DECT); Common Interface (CI); Part 3: Medium access control layer".
- [2] ETSI EN 300 175-6: "Digital Enhanced Cordless Telecommunications (DECT); Common interface; Part 6: Identities and addressing".
- [3] ETSI EN 300 175-7: "Digital Enhanced Cordless Telecommunications (DECT); Common interface; Part 7: Security features".
- [4] ETSI EN 301 649: "Digital Enhanced Cordless Telecommunications (DECT); DECT Packet Radio Services (DPRS)".
- [5] ETSI ETS 300 406: "Methods for Testing and Specification (MTS); Protocol and profile conformance testing specifications; Standardization methodology".
- [6] ISO/IEC 9646-1: "Information technology - Open Systems Interconnection - Conformance testing methodology and framework - Part 1: General concepts". (See also CCITT Recommendation X.290).
- [7] ISO/IEC 9646-2: "Information technology - Open Systems Interconnection - Conformance testing methodology and framework - Part 2: Abstract test suite specification". (See also CCITT Recommendation X.291).
- [8] ISO/IEC 9646-6: "Information technology - Open Systems Interconnection - Conformance testing methodology and framework - Part 6: Protocol profile test specification".
- [9] ISO/IEC 9646-7: "Information technology - Open Systems Interconnection - Conformance testing methodology and framework - Part 7: Implementation conformance statement".
- [10] ETSI EN 301 469-7: "Digital Enhanced Cordless Telecommunications (DECT); DECT Packet Radio Service (DPRS) Test Case Library (TCL); Part 7: Test Suite Structure (TSS) and Test Purposes (TP) - Network (NWK) layer".

3 Definitions and abbreviations

3.1 Definitions

For the purposes of the present document, the following terms and definitions apply:

- a) the terms given in ISO/IEC 9646-7 [9]; and
- b) the definitions given in EN 300 175-3 [1].

3.2 Abbreviations

For the purposes of the present document, the abbreviations given in ISO/IEC 9646-1 [6], ISO/IEC 9646-6 [8], ISO/IEC 9646-7 [9] and EN 300 175-3 [1] apply. In particular, the following abbreviations apply:

| | |
|----------------|---|
| ARQ | Automatic Repeat Request |
| BI | Invalid Behaviour |
| BV | Valid Behaviour |
| C/L | Connectionless |
| CA | Capability tests |
| C _F | higher layer signalling Channel (fast) |
| CI | Common Interface |
| C-Plane | Control Plane |
| C _S | higher layer signalling Channel (slow) |
| DLC | Data Link Control |
| FP | Fixed Part |
| FT | Fixed radio Termination |
| I | higher layer Information channel (see I _N and I _P) |
| I _N | higher layer Information channel (unprotected) |
| I _P | higher layer Information channel (protected) |
| IUT | Implementation Under Test |
| LLME | Lower Layer Management Entity |
| MAC | Medium Access Control |
| N _T | identities channel |
| PDU | Protocol Data Unit |
| PICS | Protocol Implementation Conformance Statement |
| PP | Portable Part |
| P _T | Paging channel |
| PT | Portable radio Termination |
| Q _T | system information channel |
| RF | Radio Frequency |
| RFP | Radio Fixed Part |
| TP | Test Purposes |
| TSS | Test Suite Structure |
| U-Plane | User Plane |

4 Test suite structure

4.1 Overview

MAC layer is layer 2a of the DECT protocol stack.

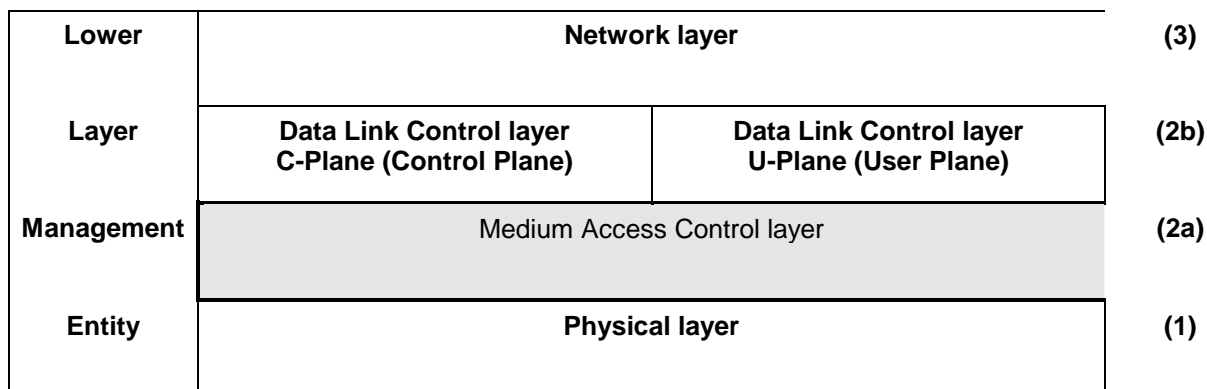

Figure 1: DECT protocol stack

MAC layer specifies three groups of services:

- the broadcast message control service;
- the connectionless message control service; and
- the multi-bearer control service.

The MAC layer also specifies the logical channels that are used by the above mentioned services, and how they are multiplexed and mapped into the service data units that are exchanged with the physical layer.

Figure 2 shows the MAC Test Suite Structure (TSS) including its subgroups defined for the conformance testing.

| Test Suite | Protocol group | Protocol subgroup | Test group | |
|-------------------|-----------------------|--------------------------|--------------------------|----|
| MAC | General | Broadcast services | Downlink broadcast | CA |
| | | | Non continuous broadcast | CA |
| | Advanced connection | | Paging services | CA |
| | | | Bearer setup | BV |
| | | | Connection modification | CA |
| | | | Bearer release | CA |
| | | | Bearer handover | CA |
| | | | Connection handover | CA |
| | | | C-plane services | CA |
| | U-plane services | CA | | |
| | Encryption | MAC layer management | | BV |
| | | | | BI |
| | | | | CA |
| | | | | CA |

Figure 2: TSS for DECT MAC layer (layer 2a of DECT protocol stack)

4.2 Test suite structure (TSS)

The test suite is structured as a tree with a first level defined as MAC representing the protocol group "MAC for PP and FP".

4.3 Test groups

The test groups are organized in three levels. The first level creates seven protocol groups representing the protocol services. The second level, if the third level exists, separates the protocol services in functional modules. The last level in each branch contains one or more of the standard ISO subgroups CA, BV and BI.

4.3.1 Protocol groups

The protocol groups identifies the DECT MAC services: general services, broadcast services, advanced connection services, C-plane services, U-plane services, encryption procedures, layer management procedures, as defined in EN 300 175-3 [1].

4.3.1.1 General services

The general services protocol group contains directly the main test group CA.

4.3.1.2 Broadcast services

The broadcast services protocol group is divided in three functional modules. The first functional module identifies the downlink broadcast services. The second functional module identifies the non-continuous broadcast services. The last functional module identifies the paging services.

4.3.1.3 Advanced connection services

The advanced connection services protocol group is divided in five functional modules. The first functional module distinguishes the bearer setup subgroup. The second functional module distinguishes the connection modification subgroup. The third functional module distinguishes the bearer handover subgroup. The fourth functional module distinguishes the bearer release subgroup. The last functional module distinguishes the connection handover subgroup.

4.3.1.4 C-plane services

The C-plane services protocol group contains directly the main test group CA.

4.3.1.5 U-plane services

The U-plane services protocol group contains directly the main test groups CA, BV and BI.

4.3.1.6 Encryption

The encryption protocol group contains directly the main test group CA.

4.3.1.7 Layer management procedures

The layer management procedures protocol group contains directly the main test group CA.

4.3.2 Main test groups

The main test groups are the capability group, the valid behaviour group and the invalid behaviour group.

4.3.2.1 Capability (CA) tests

This test sub group shall provide limited testing of the major IUT capabilities aiming to insure that the claimed capabilities are correctly supported, according to the PICS.

4.3.2.2 Valid Behaviour (BV) tests

This test sub group shall verify that the IUT reacts in conformity with the DSPR standard [4], after receipt or exchange of a valid Protocol Data Units (PDUs). Valid PDUs means that the exchange of messages and the content of the exchanged messages are considered as valid.

4.3.2.3 Invalid Behaviour (BI) tests

This test sub group shall verify that the IUT reacts in conformity with the DSPR standard [4], after receipt of a syntactically invalid PDU.

5 Test Purposes (TP)

5.1 Introduction

5.1.1 TP definition conventions

The TPs are defined following particular rules as shown in table 1.

Table 1: TP definition rules

| TP Id according to the TP naming conventions | Reference. Initial condition. Stimulus. Expected behaviour. |
|--|---|
| TP Id | The TP Id is a unique identifier it shall be specified according to the TP naming conventions defined in the subclause below. |
| Reference | The reference should contain the references of the subject to be validated by the actual TP (specification reference, clause, paragraph). |
| Condition | The condition defines in which initial state the IUT has to be to apply the actual TP. |
| Stimulus | The stimulus defines the test event to which the TP is related. |
| Expected behaviour | Definition of the events that are expected from the IUT to conform to the base specification. |

5.1.2 TP naming conventions

The identifier of the TP is built according to table 2.

Table 2: TP naming convention

| Identifier: | TP/<fm>/<x>-<nn> | | |
|--------------------------|------------------|---------|--------------------------|
| <fm> = functional module | | DB | Downlink Broadcast |
| | | PG | Paging services |
| | | NB | Non Continuous Broadcast |
| | | BS | Bearer setup |
| | | CM | Connection modification |
| | | BH | Bearer handover |
| | | BR | Bearer release |
| | | CH | Connection handover |
| | | DT | C-plane services |
| | | UP | U-plane services |
| | | EN | Encryption |
| | | LM | Layer Management |
| x = Type of testing | | CA | Capability Tests |
| | | BV | Valid Behaviour Tests |
| | | BI | Invalid Behaviour Tests |
| <nn> = sequential number | | (00-99) | Test Purpose Number |

5.1.3 Sources of TP definitions

All TPs are specified according to EN 300 175-3 [1] with respect to the requirements expressed in EN 301 649 [4].

5.2 Test purposes for FT part

5.2.1 TP presentation

Test purposes are presented by a logical grouping related to MAC services. The naming is in line with the test suite structure. Test purposes which do not already exist in the CI test case library are highlighted by having the word data in their test purpose name.

5.2.2 General services

5.2.2.1 MAC service and procedure concerned

| | | |
|-------------|---------|--|
| M.1 General | | |
| | General | EN 300 175-3 [1]: 4.2, 6.2.1, 6.2.2, 6.2.3, 6.2.4, 6.2.5, 7.1.2, 7.1.4, 11.3.3, 11.7, 11.8, 11.9 |

5.2.2.2 Test purposes

No specific test purposes are defined for the M.1 General service. Format, Coding, Multiplex, Scrambling, etc. are implicitly tested in other tests defined in the present document.

5.2.3 Broadcast services

5.2.3.1 Downlink broadcast

| | |
|------------------------------|---|
| Test group objective: | Verify the correct implementation of the Downlink broadcast services. |
|------------------------------|---|

5.2.3.1.1 MAC service and procedure concerned

| | | |
|----------------------------|---|---|
| M.3 Continuous broadcast | | |
| | Downlink broadcast | EN 300 175-3 [1]: 7.2.2, 7.2.3.2, 7.2.3.3, 7.2.3.4, 7.2.3.5 |
| M.11 Encryption activation | | |
| | Encryption process - initialization and synchronization | EN 300 175-7 [3]: 6.4.4, 6.4.5 |
| M.15 SARI support | | |
| | Downlink broadcast | EN 300 175-3 [1]: 7.2.3.6 |

5.2.3.1.2 CA test purposes

| | |
|----------------------------|--|
| Subgroup objective: | Limited testing that the observable capabilities of the IUT concerning the Downlink broadcast services are in accordance with the static conformance requirements. |
|----------------------------|--|

| Test purposes: | |
|-----------------------|--|
| TP/FT/DB/CA-00 | DPRS service M.3 Continuous broadcast EN 300 175-3 [1]: 6.2.2.1 Initial state: Active_idle. Check that the IUT transmits constantly at least in frame 14 of each multiframe, the correct N_T message. |
| TP/FT/DB/CA-01 | DPRS service M.3 Continuous broadcast EN 300 175-3 [1]: 6.2.2.1 to 9.1.3.1 Initial state: Active_idle. Check that the IUT transmits constantly at least once every T205 seconds in frame 0, the correct N_T message. |
| TP/FT/DB/CA-02 | DPRS service M.3 Continuous broadcast EN 300 175-3 [1]: 6.2.2.1 to 7.2.3 Initial state: Active_idle. Check that the IUT transmits constantly one correct Q_T message in frame 8 of each multiframe. |
| TP/FT/DB/CA-03 | DPRS service M.3 Continuous broadcast EN 300 175-3 [1]: 6.2.2.1 to 7.2.3.2 Initial state: Active_idle. Check that the IUT transmits constantly at least one static system information Q_T message in each interval of 8 multiframe and that all such messages are correct. |
| TP/FT/DB/CA-04 | DPRS service M.3 Continuous broadcast EN 300 175-3 [1]: 6.2.2.1 to 7.2.3.4 Initial state: Active_idle. Check that the IUT transmits constantly at least one fixed Part capabilities Q_T message in each interval of 8 multiframe and that all such messages are correct. |
| TP/FT/DB/CA-05 | DPRS services M.3 Continuous broadcast and M.11 Encryption activation EN 300 175-3 [1]: 6.2.2.1 to 7.2.3 Only for FT supporting encryption. Initial state: Active_idle. Check that the IUT transmits constantly at least one multiframe number Q_T message in each interval of 8 multiframe and that all such messages are correct. |
| TP/FT/DB/CA-06 | DPRS service M.15 SARI support EN 300 175-3 [1]: 6.2.2.1 to 7.2.3.6 Only for FT supporting SARI. Initial state: Active_idle. Check that the IUT transmits constantly at least one SARI list content Q_T message in each interval of 4 multiframe and that all such messages are correct. |
| TP/FT/DB/CA-07 | DPRS service M.3 Continuous broadcast EN 300 175-3 [1]: 6.2.2.1 to 7.2.3.3 Only for FT supporting extended RF. Initial state: Active_idle. Check that the IUT transmits the correct "Extended RF carrier information" Q_T message in the multi-frame following the "Static system information" Q_T message with the Extended RF carrier bit set. |
| TP/FT/DB/CA-51 | DPRS service M.3 Continuous broadcast EN 300 175-3 [1]: 7.2.4.3.9 Only for FT supporting RFP status. Initial state: Active_idle. Check that the IUT broadcasts the RFP status message at least once every 10 seconds. |
| TP/FT/DB/CA-52 | DPRS service M.3 Continuous broadcast EN 300 175-3 [1]: 6.2.2.1 to 7.2.3.5 Only for FT supporting extended fixed Part capabilities. Initial state: Active_idle. Check that the IUT broadcasts the extended fixed Part capabilities message at least once in every 8 multi frames. |

5.2.3.1.3 BV test purposes

| | |
|----------------------------|---|
| Subgroup objective: | To test the behaviour of the IUT concerning the Downlink broadcast services in relation to syntactically and contextual correct behaviour of the test system. |
|----------------------------|---|

| Test purposes: | |
|-----------------------|---|
| TP/FT/DB/BV-03 | DPRS service M.15 SARI support EN 300 175-3 [1]: 6.2.2.1 to 7.2.2; EN 300 175-6 [2]: 7.1 Initial state: Inactive. Check that once a SARI is introduced into the FT, the E-bit within the N_T message is indicating SARI list available. |

5.2.3.2 Non continuous broadcast

| | |
|------------------------------|---|
| Test group objective: | Verify the correct implementation of the Non continuous broadcast services. |
|------------------------------|---|

5.2.3.2.1 MAC service and procedure concerned

| | | |
|------------------------------|--|---------------------------|
| M.2 Non continuous broadcast | | |
| | Request for specific Q-channel information | EN 300 175-3 [1]: 9.3.1.2 |
| | Request for a new dummy | EN 300 175-3 [1]: 9.3.2 |

5.2.3.2.2 CA test purposes

| | |
|----------------------------|--|
| Subgroup objective: | Limited testing that the observable capabilities of the IUT concerning the non continuous broadcast services are in accordance with the static conformance requirements. |
|----------------------------|--|

| Test purposes: | |
|---------------------------|--|
| TP/FT/NB/CA-data00 | DPRS service M.2 Non continuous broadcast EN 300 175-3 [1]: 9.3.1.2 Initial state: Active_idle. Check that the IUT reply correctly to a request for extended system information initiated by the Tester acting as a PT. |
| TP/FT/NB/CA-data01 | DPRS service M.2 Non continuous broadcast EN 300 175-3 [1]: 9.3.1.2 Initial state: Active_idle. Check that the IUT reply correctly to a request for a new dummy (ignore or install) initiated by the Tester acting as a PT. |

5.2.3.3 Paging services

| | |
|------------------------------|---|
| Test group objective: | Verify the correct implementation of the paging services. |
|------------------------------|---|

5.2.3.3.1 MAC service and procedure concerned

| | | |
|----------------------|------------------------|-----------------------------------|
| M.4 Paging broadcast | | |
| | Normal paging | EN 300 175-3 [1]: 9.1.3, 11.3.3.1 |
| | High duty cycle paging | EN 300 175-3 [1]: 9.1.3, 11.3.3.1 |
| | Low duty cycle paging | EN 300 175-3 [1]: 9.1.3, 11.3.3.1 |

5.2.3.3.2 CA test purposes

| | |
|----------------------------|--|
| Subgroup objective: | Limited testing that the observable capabilities of the IUT concerning the paging services are in accordance with the static conformance requirements. |
|----------------------------|--|

| Test purposes: | |
|---------------------------|---|
| TP/FT/PG/CA-00 | DPRS service M.4 Paging broadcast EN 300 175-3 [1]: 9.1.3 Initial state: Active_idle. Check that the IUT can transmit a short page message. |
| TP/FT/PG/CA-01 | DPRS service M.4 Paging broadcast EN 300 175-3 [1]: 9.1.3 Only for FT that has blind slots or moving dummy bearer or does not support bearer handover within the whole FT. Initial state: Active_idle. Check that the FT can transmit a correct zero length page message. |
| TP/FT/PG/CA-data00 | DPRS service M.4 Paging broadcast EN 300 175-3 [1]: 9.1.3 Initial state: Active_idle. Check that the IUT can transmit a full page message. |
| TP/FT/PG/CA-data01 | DPRS service M.4 Paging broadcast EN 300 175-3 [1]: 9.1.3 Initial state: Active_idle. Check that the IUT manages correctly the flag for sequencing a long NWK page message into some 36 bits page messages contained in the same multi-frame. |

5.2.3.3.3 BV test purposes

| | |
|----------------------------|--|
| Subgroup objective: | To test the behaviour of the IUT in relation to syntactically and contextual correct behaviour of the test system. |
|----------------------------|--|

| Test purposes: | |
|---------------------------|--|
| TP/FT/PG/BV-01 | DPRS service M.4 Paging broadcast EN 300 175-3 [1]: 11.8 Only for FT that shall transmit blind slot information. Initial state: Active_idle. Check that the IUT periodically announces (at least every 10 s) its blind slots. |
| TP/FT/PG/BV-data00 | DPRS service M.4 Paging broadcast EN 300 175-3 [1]: 9.1.3 Only for IUT, for which it is possible to describe a procedure to avoid frame 0 during the test. Initial state: Active_idle. Check that the IUT uses directly a frame number 2, 4, 6, 10, 12 of a multiframe when fast paging is required. (IUT has to be configured to avoid frame 0) |
| TP/FT/PG/BV-data01 | DPRS service M.4 Paging broadcast EN 301 649 [4]: 10.4.1.4 Initial condition: The Tester acting as PT is configured for non-support of Fast Setup. Initial state: Active_idle. Check that the IUT, to resume a suspended connection, sends a MAC resume page message to invite the PT to initiate the resume connection procedure. |
| TP/FT/PG/BV-data02 | DPRS service M.4 Paging broadcast EN 301 649 [4]: 10.4.2 Condition: Only if the IUT supports the SI _p channel. Initial state: Active_idle. Check that the IUT announces new connectionless downlink bearers for SI _p data by broadcast of the MAC layer information "Dummy or C/L bearer" or "C/L bearer position" at least each 4 multiframe. |

5.2.4 Advanced connection

5.2.4.1 Bearer setup procedures

| | |
|------------------------------|---|
| Test group objective: | Verify the correct implementation of Bearer setup procedures. |
|------------------------------|---|

5.2.4.1.1 MAC service and procedure concerned

| | | |
|-------------------------|--|---|
| M.5 Advanced connection | | |
| | PT initiated pilot bearer setup | EN 300 175-3 [1]: 10.5.1.3.1 |
| | FT initiated pilot bearer setup (Fast setup) | EN 300 175-3 [1]: 10.5.1.3.2 |
| | Additional bearer setup (duplex) | EN 300 175-3 [1]: 10.2.4.3, 10.5.1.3 |
| | Additional bearer setup (double simplex) | EN 300 175-3 [1]: 10.2.4.3, 10.5.1.4 |

5.2.4.1.2 CA test purposes

| | |
|----------------------------|---|
| Subgroup objective: | Limited testing that the observable capabilities of the IUT concerning the advanced connection procedures are in accordance with the static conformance requirements. |
|----------------------------|---|

| Test purposes: | |
|---------------------------|---|
| TP/FT/BS/CA-data00 | DPRS service M.5 Advanced connection EN 300 175-3 [1]: 10.5.1.3.1 Initial state: Active_Idle Check that the IUT manages rightly the PT initiated B-field single bearer setup procedure. |
| TP/FT/BS/CA-data01 | DPRS service M.5 Advanced connection EN 300 175-3 [1]: 10.5.1.3.2 Initial state: Active_Idle Check that the IUT manages rightly the FT initiated B-field single bearer fast setup procedure without wait messages. |
| TP/FT/BS/CA-data02 | DPRS service M.5 Advanced connection EN 300 175-3 [1]: 10.5.1.3.2 Initial state: Active_Idle Check that the IUT manages rightly the FT initiated B-field single bearer fast setup procedure with wait messages. |
| TP/FT/BS/CA-data03 | DPRS service M.5 Advanced connection EN 300 175-3 [1]: 10.5.1.3 Initial state: Active_idle. Check that the IUT manages rightly the PT initiated B-field duplex bearer setup procedure for additional bearers of a symmetric multibearer connection. |
| TP/FT/BS/CA-data04 | DPRS service M.5 Advanced connection EN 300 175-3 [1]: 10.5.1.4 Only for IUT that supports double simplex bearer. Initial state: Active_idle. Check that the IUT is able to handle double simplex bearer setup procedure, initiated by the tester for additional bearers of an asymmetric multibearer connection. |

5.2.4.2 Connection modification procedures

| | |
|------------------------------|--|
| Test group objective: | Verify the correct implementation of connection modification procedures. |
|------------------------------|--|

5.2.4.2.1 MAC service and procedure concerned

| | | |
|-------------------------|-------------------------|------------------------|
| M.5 Advanced connection | | |
| | Connection modification | EN 300 175-3 [1]: 10.3 |

5.2.4.2.2 CA test purposes

| | |
|----------------------------|---|
| Subgroup objective: | Limited testing that the observable capabilities of the IUT concerning the connection modification procedures are in accordance with the static conformance requirements. |
|----------------------------|---|

| Test purposes: | |
|---------------------------|---|
| TP/FT/CM/CA-data00 | DPRS service M.5 Advanced connection EN 300 175-3 [1]: 10.3 Initial State: Active_Traffic. Verify that the IUT is able to handle correctly a connection modification changing the number of bearers used in a symmetric multibearer connection. |
| TP/FT/CM/CA-data01 | DPRS service M.5 Advanced connection EN 300 175-3 [1]: 10.3 Only for IUT that supports asymmetric connection. Initial State: Active_Traffic. Verify that the IUT is able to handle correctly a connection modification changing the number of bearers used in an asymmetric multibearer connection. |

5.2.4.3 Bearer release procedures

| | |
|------------------------------|---|
| Test group objective: | Verify the correct implementation of bearer release procedures. |
|------------------------------|---|

5.2.4.3.1 MAC service and procedure concerned

| | | |
|-------------------------|---------------------------------|----------------------------|
| M.5 Advanced connection | | |
| | Unacknowledged bearer release | EN 300 175-3 [1]: 10.7.2.1 |
| | Acknowledged bearer release | EN 300 175-3 [1]: 10.7.2.2 |
| | Bandwidth reversal fast release | EN 300 175-3 [1]: 10.7.2.3 |

5.2.4.3.2 CA test purposes

| | |
|----------------------------|--|
| Subgroup objective: | Limited testing that the observable capabilities of the IUT concerning the bearer release procedures are in accordance with the static conformance requirements. |
|----------------------------|--|

| Test purposes: | |
|---------------------------|---|
| TP/FT/BR/CA-data00 | DPRS service M.5 Advanced connection EN 300 175-3 [1]: 10.7.2.1 Initial state: Active_traffic or Active_traffic_and_idle. Check that the IUT manages rightly the release of an advanced duplex bearer with an unacknowledge release procedure when receiving a release message. |
| TP/FT/BR/CA-data01 | DPRS service M.5 Advanced connection EN 300 175-3 [1]: 10.7.2.2 Only for IUT that supports asymmetric connection. Initial state: Active_traffic or Active_traffic_and_idle. Check that the IUT manages rightly the release of a double simplex bearer with an acknowledge release procedure when receiving a release message. |
| TP/FT/BR/CA-data02 | DPRS service M.5 Advanced connection EN 300 175-3 [1]: 10.4 Initial state: Active_traffic. Check that the IUT manages rightly a release of a multibearer connection requested by the DLC layer by releasing all active bearers. |
| TP/FT/BR/CA-data03 | DPRS service M.5 Advanced connection EN 300 175-3 [1]: 10.7.2.3 Only for IUT that supports asymmetric connection. Initial State: Active_Traffic. Verify that the IUT is able to handle correctly a connection modification reversing the direction of an asymmetric multibearer connection |

5.2.4.4 Bearer handover procedures

| | |
|------------------------------|--|
| Test group objective: | Verify the correct implementation of bearer handover procedures. |
|------------------------------|--|

5.2.4.4.1 MAC service and procedure concerned

| | | |
|----------------------|-------------------------|------------------------------------|
| M.17 Bearer handover | | |
| | Bearer handover request | EN 300 175-3 [1]: 10.6.2, 10.5.1.1 |

5.2.4.4.2 CA test purposes

| | |
|----------------------------|---|
| Subgroup objective: | Limited testing that the observable capabilities of the IUT concerning the bearer handover procedures are in accordance with the static conformance requirements. |
|----------------------------|---|

| Test purposes: | |
|-----------------------|---|
| TP/FT/BH/CA-01 | DPRS service M.17 Bearer handover EN 300 175-3 [1]: 10.6 Only for FT supporting intercell bearer handover. Initial state: Active_traffic or Active_traffic_and_idle. Check that the IUT responds rightly to a PT initiated intercell bearer handover procedure. |

5.2.4.5 Connection handover procedures

| | |
|------------------------------|---|
| Test group objective: | Verify the correct implementation of bearer release procedures. |
|------------------------------|---|

5.2.4.5.1 MAC service and procedure concerned

| | | |
|--------------------------|------------------------------|--|
| M.18 Connection handover | | |
| | Advanced connection handover | EN 300 175-3 [1]: 10.2.4.3, 10.5.1.3.1 |

5.2.4.5.2 Test purposes

The behaviour of the connection handover procedures of the MAC layer of the IUT is tested at the NWK layer level of the test specification (EN 301 469-7 [10]).

5.2.5 C-plane higher layer signalling

| | |
|------------------------------|--|
| Test group objective: | Verify the correct implementation of C-plane higher layer signalling procedures. |
|------------------------------|--|

5.2.5.1 MAC service and procedure concerned

| | | |
|---|-----------------------------|------------------------------------|
| M.9 C _S higher layer signalling | | |
| | C _S channel data | EN 300 175-3 [1]: 10.8.1, 10.8.1.1 |
| M.10 C _F higher layer signalling | | |
| | C _F channel data | EN 300 175-3 [1]: 10.8.1, 10.8.1.2 |

5.2.5.2 CA test purposes

| | |
|----------------------------|---|
| Subgroup objective: | Limited testing that the observable capabilities of the IUT concerning the C-plane higher layer signalling procedures are in accordance with the static conformance requirements. |
|----------------------------|---|

| Test purposes: | |
|---------------------------|--|
| TP/FT/DT/CA-00 | DPRS service M.9 C _S higher layer signalling EN 300 175-3 [1]: 10.8.1.1 Initial state: Active_traffic or Active_traffic_and_idle. Check that the IUT re-transmits C _S segment until it receives an acknowledgement in the same Automatic Repeat Request (ARQ) window. |
| TP/FT/DT/CA-01 | DPRS service M.9 C _S higher layer signalling EN 300 175-3 [1]: 10.8.1.1 Initial state: Active_traffic or Active_traffic_and_idle. Check that the IUT does not transmit another C _S segment until the successful transmission of the current segment. |
| TP/FT/DT/CA-02 | DPRS service M.9 C _S higher layer signalling EN 300 175-3 [1]: 10.8.1.1 Initial state: Active_traffic or Active_traffic_and_idle. Check that the IUT manages correctly the one bit numbering of the C _S segments. |
| TP/FT/DT/CA-data00 | DPRS service M.10 C _F higher layer signalling EN 300 175-3 [1]: 10.8.1.2 Only for IUT that supports C _F channel. Initial state: Active_traffic or Active_traffic_and_idle. Check that the IUT re-transmits a set of C _F segment until it receives an acknowledgement in the same Automatic Repeat Request (ARQ) window. |
| TP/FT/DT/CA-data01 | DPRS service M.10 C _F higher layer signalling EN 300 175-3 [1]: 10.8.1.2 Only for IUT that supports C _F channel. Initial state: Active_traffic or Active_traffic_and_idle. Check that the IUT does not transmit another set of C _F segment until the successful transmission of the current set. |
| TP/FT/DT/CA-data02 | DPRS service M.10 C _F higher layer signalling EN 300 175-3 [1]: 10.8.1.2 Only for IUT that supports C _F channel. Initial state: Active_traffic or Active_traffic_and_idle. Check that the IUT manages correctly the one bit numbering of the set of C _F segments. |

5.2.6 U-plane services

| | |
|------------------------------|--|
| Test group objective: | Verify the correct implementation of U-plane procedures. |
|------------------------------|--|

5.2.6.1 MAC service and procedure concerned

| | | |
|--|------------------------------------|---|
| M.6 I _P _error_detection service | | |
| | I _P -error-detect mode | EN 301 649 [4]: 10.9.1 |
| M.7 I _P _error_correction service | | |
| | I _P -error-correct mode | EN 301 649 [4]: 10.9.2 |
| | Unilateral jump | EN 301 649 [4]: D.1.4 |
| | Bearer reset | EN 300 175-3 [1]: 10.8.2.5.3 |
| M.8 U-plane point-to-multipoint service | | |
| | Connectionless SIp mode | EN 301 649 [4]: D.1.1 |
| M.16 Bearer replacement | | |
| | Bearer replacement | EN 300 175-3 [1]: 10.8.2.5.1, EN 301 649 [4]: D.1.5 |

5.2.6.2 CA test purposes

| | |
|----------------------------|---|
| Subgroup objective: | Limited testing that the observable capabilities of the IUT concerning the U-plane procedures are in accordance with the static conformance requirements. |
|----------------------------|---|

| Test purposes: | |
|---------------------------|--|
| TP/FT/UP/CA-data00 | DPRS service M.6 I _P _error_detection EN 301 649 [4]: 10.13.1 Initial state: Active_traffic or Active_traffic_and_idle. Verify that the IUT is able to receive I _P -error-detect data for a symmetric connection. |
| TP/FT/UP/CA-data01 | DPRS service M.6 I _P _error_detection EN 301 649 [4]: 10.13.1 Initial state: Active_traffic or Active_traffic_and_idle. Verify that the IUT is able to receive I _P -error-detect data for an asymmetric connection. |
| TP/FT/UP/CA-data02 | DPRS service M.7 I _P _error_correction EN 301 649 [4]: 10.13.1 Only for IUT that supports I _P -error-correct service. Initial state: Active_traffic or Active_traffic_and_idle. Verify that the IUT is able to receive I _P -error-correct data for a symmetric connection and react with the correct settings of BCK and Q2 bits. |
| TP/FT/UP/CA-data03 | DPRS service M.7 I _P _error_correction EN 301 649 [4]: 10.13.1 Only for IUT that supports I _P -error-correct service. Initial state: Active_traffic or Active_traffic_and_idle. Verify that the IUT is able to receive I _P -error-correct data for an asymmetric connection and react with the correct MAC-mod2-ACK message. |
| TP/FT/UP/CA-data04 | DPRS service M.7 I _P _error_correction EN 300 175-3 [1]: 10.8.5.3 Only for IUT that supports I _P -error-correct service. Initial state: Active_Traffic or Active_Traffic_and_Idle. Check that the IUT manages rightly the MAC I _P bearer reset procedure. |
| TP/FT/UP/CA-data05 | DPRS service M.16 Bearer replacement EN 300 175-3 [1]: 10.8.2.5.1; EN 301 649 [4]: D.1.5 Initial state: Active_Traffic or Active_Traffic_and_Idle. Check that the IUT manages rightly the bearer replacement procedure. |
| TP/FT/UP/CA-data06 | DPRS service M.8 U-plane point-to-multipoint EN 301 649 [4]: 10.13.3 Only for IUT that supports SIp channel. Initial state: Active_idle. Check that the IUT, is able to transmit SIp data on connectionless downlink bearers. |

5.2.6.3 BI test purposes

| | |
|----------------------------|---|
| Subgroup objective: | To check the behaviour of the of the IUT in response to invalid messages. |
|----------------------------|---|

| Test purposes: | |
|---------------------------|---|
| TP/FT/UP/BI-data00 | DPRS service M.7 I _P _error_correction EN 300 175-3 [1]: 10.8.2.4.1 Only for IUT that supports Ip-error-correct service. Initial state: Active_Traffic or Active_Traffic_and_Idle. Check that the IUT, when receiving I _P _error_correction data on a duplex bearer, is capable of detecting A-field R-CRC error and to respond with the correct Q2 bit setting (Q2 = 0). |
| TP/FT/UP/BI-data01 | DPRS service M.7 I _P _error_correction EN 300 175-3 [1]: 10.8.2.4.1 Only for IUT that supports Ip-error-correct service. Initial state: Active_Traffic or Active_Traffic_and_Idle. Check that the IUT, when receiving I _P _error_correction data on an asymmetric double simplex bearer, is capable of detecting A-field R-CRC error and to respond with the correct ACK bit setting indicating the packet number of the last correctly received I _P packet. |

5.2.7 Encryption

| | |
|------------------------------|---|
| Test group objective: | Verify the correct implementation of encryption procedures. |
|------------------------------|---|

5.2.7.1 MAC service and procedure concerned

| | | |
|------------------------------|---|--------------------------------|
| M.11 Encryption activation | | |
| | Encryption process - initialization and synchronization | EN 300 175-7 [3]: 6.4.4, 6.4.5 |
| | Encryption mode control | EN 300 175-7 [3]: 6.4.6 |
| | PT Encryption activation | EN 300 175-7 [3]: 6.4.6.3 |
| | Encryption handover control | EN 300 175-7 [3]: 6.4.7 |
| M.12 Encryption deactivation | | |
| | PT Encryption deactivation | EN 300 175-7 [3]: 6.4.6.4 |

5.2.7.2 CA test purposes

| | |
|----------------------------|--|
| Subgroup objective: | Limited testing that the observable capabilities of the IUT concerning the encryption procedures are in accordance with the static conformance requirements. |
|----------------------------|--|

| Test purposes: | |
|---------------------------|---|
| TP/FT/EN/CA-data00 | DPRS service M.11 Encryption activation EN 300 175-7 [3]: 6.4 Only for IUT supporting encryption. Initial state: Active_Traffic or Active_Traffic_and_Idle. Check that the IUT manages correctly the procedure to switch an advanced connection from clear mode to encrypt mode. |
| TP/FT/EN/CA-data01 | DPRS service M.12 Encryption deactivation EN 300 175-7 [3]: 6.4 Only for IUT supporting encryption deactivation. Initial state: Active_Traffic or Active_Traffic_and_Idle. Check that the IUT manages correctly the procedure to switch an advanced connection from encrypt mode to clear mode. |

5.2.8 MAC layer management

| | |
|------------------------------|--|
| Test group objective: | Verify the correct implementation of the LLME MAC layer management procedures. |
|------------------------------|--|

5.2.8.1 MAC service and procedure concerned

| | | |
|---------------------------------|-----------------------------------|--------------------------------|
| M.2 Non continuous broadcast | | |
| | Extended system information | EN 300 175-3 [1]: 11.2 |
| M.13 Quality control | | |
| | RFPI handshake | EN 300 175-3 [1]: 11.5.1 |
| | PT frequency correction procedure | EN 300 175-3 [1]: 11.5.2.2 |
| M.14 Physical channel selection | | |
| | Physical channel selection | EN 300 175-3 [1]: 11.4, 10.5.2 |

5.2.8.2 CA test purposes

| | |
|----------------------------|---|
| Subgroup objective: | Limited testing that the observable capabilities of the IUT concerning the LLME MAC layer management procedures are in accordance with the static conformance requirements. |
|----------------------------|---|

| Test purposes: | |
|---------------------------|---|
| TP/FT/LM/CA-data00 | DPRS service M.2 Non continuous broadcast EN 300 175-3 [1]: 11.2 Initial state: Active_traffic or Active_traffic_and_idle. Check that the IUT responds correctly within T206 frames to a Tester (acting as a PT part) request for Extended system information. |
| TP/FT/LM/CA-data01 | DPRS service M.13 Quality control. EN 300 175-3 [1]: 10.5.1.1 - 11.5.1 Initial state: Active_traffic or Active_traffic_and_idle. Check that the IUT releases a bearer if it has not received the correct RFPI on that bearer in the last T201 seconds during the time an advanced connection exists. |

5.3 Test purposes for PT part

5.3.1 TP presentation

Test purposes are presented by a logical grouping related to MAC services. The naming is in line with the test suite structure. Test purposes which do not already exist in the CI test case library are highlighted by having the word data in their test purpose name.

5.3.2 General services

5.3.2.1 MAC service and procedure concerned

| | | |
|-------------|---------|--|
| M.1 General | | |
| | General | EN 300 175-3 [1]: 4.2, 6.2.1, 6.2.2, 6.2.3, 6.2.4, 6.2.5, 7.1.2, 7.1.4, 11.3.3, 11.7, 11.8, 11.9 |

5.3.2.2 Test purposes

No specific test purposes are defined for the M.1 General service. Format, Coding, Multiplex, Scrambling, etc.. are implicitly tested in other tests defined in the present document.

5.3.3 Broadcast services

5.3.3.1 Downlink broadcast

| | |
|------------------------------|---|
| Test group objective: | Verify the correct implementation of the Downlink broadcast services. |
|------------------------------|---|

5.3.3.1.1 MAC service and procedure concerned

| | | |
|----------------------------|---|---|
| M.3 Continuous broadcast | Downlink broadcast | EN 300 175-3 [1]: 7.2.2, 7.2.3.2, 7.2.3.3, 7.2.3.4, 7.2.3.5 |
| M.11 Encryption activation | Encryption process - initialization and synchronization | EN 300 175-7 [3]: 6.4.4, 6.4.5 |
| M.15 SARI support | Downlink broadcast | EN 300 175-3 [1]: 7.2.3.6 |

5.3.3.1.2 CA test purposes

No TPs are defined for downlink broadcast services CA tests in the present document.

5.3.3.1.3 BV test purposes

| | |
|----------------------------|---|
| Subgroup objective: | To test the behaviour of the IUT concerning the Downlink broadcast services in relation to syntactically and contextual correct behaviour of the test system. |
|----------------------------|---|

| Test purposes: | |
|-----------------------|--|
| TP/PT/DB/BV-01 | DPRS service M.3 Continuous broadcast EN 300 175-3 [1]: 7.2.3.3 Initial state: Idle_locked. Check that the IUT is able to establish a bearer after reception of the extended RF carrier information Q _T message. |
| TP/PT/DB/BV-02 | DPRS service M.15 SARI support EN 300 175-3 [1]: 11.3.2 EN 300 175-6 [2]: 5.6 Initial state: Active_unlocked. Check that the IUT enters the idle locked state after receiving the Q _T SARI list contents message containing ARI matching the IUT PARK (the LT PARI does not match the IUT PARK). |
| TP/PT/DB/BV-51 | DPRS service M.3 Continuous broadcast EN 300 175-3 [1]: 7.2.4.3.9 Initial state: Active_idle. Check that the IUT does not attempt to send an access request to an RFP which is broadcasting "RFP busy" in the RFP status message after reception of this status message at the IUT. |
| TP/PT/DB/BV-52 | DPRS service M.3 Continuous broadcast EN 300 175-3 [1]: 7.2.4.3.9 Initial state: Active_idle. Check that the IUT, in case of PT initiated connection resumption, does not attempt to send an access request to a FP, which is broadcasting "system busy" in the RFP status message after reception of this status message at the IUT. |

5.3.3.2 Non continuous broadcast

| | |
|------------------------------|---|
| Test group objective: | Verify the correct implementation of the non continuous broadcast services. |
|------------------------------|---|

5.3.3.2.1 MAC service and procedure concerned

| | | |
|------------------------------|--|---------------------------|
| M.2 Non continuous broadcast | | |
| | Request for specific Q-channel information | EN 300 175-3 [1]: 9.3.1.2 |
| | Request for a new dummy | EN 300 175-3 [1]: 9.3.2 |

5.3.3.2.2 Test purposes

No TPs are defined for non continuous broadcast services for PT part in the present document.

5.3.3.3 Paging services

| | |
|------------------------------|---|
| Test group objective: | Verify the correct implementation of the paging services. |
|------------------------------|---|

5.3.3.3.1 MAC service and procedure concerned

| | | |
|----------------------|------------------------|-----------------------------------|
| M.4 Paging broadcast | | |
| | Normal paging | EN 300 175-3 [1]: 9.1.3, 11.3.3.1 |
| | High duty cycle paging | EN 300 175-3 [1]: 9.1.3, 11.3.3.1 |
| | Low duty cycle paging | EN 300 175-3 [1]: 9.1.3, 11.3.3.1 |

5.3.3.3.2 CA test purposes

| Test purposes: | |
|---------------------------|---|
| TP/PT/PG/CA-00 | DPRS service M.4 Paging broadcast EN 300 175-3 [1]: 9.1.3 Initial state: Idle_locked. Check that the IUT can receive a short page message. |
| TP/PT/PG/CA-01 | DPRS service M.4 Paging broadcast EN 300 175-3 [1]: 9.1.3 Initial state: Idle_locked. Check that the IUT can receive a correct zero length page message. |
| TP/PT/PG/CA-data00 | DPRS service M.4 Paging broadcast EN 300 175-3 [1]: 9.1.3 Initial state: Idle_locked. Check that the IUT can receive a full page message. |
| TP/PT/PG/CA-data01 | DPRS service M.4 Paging broadcast EN 300 175-3 [1]: 9.1.3 Initial state: Idle_locked. Check that the IUT can receive a long page (36 bits) message. |

5.3.3.3.3 BV test purposes

| | |
|----------------------------|--|
| Subgroup objective: | To test the behaviour of the IUT in relation to syntactically and contextual correct behaviour of the test system. |
|----------------------------|--|

| Test purposes: | |
|---------------------------|--|
| TP/PT/PG/BV-02 | DPRS service M.4 Paging broadcast EN 300 175-3 [1]: 7.2.4.3 Initial state: Idle_locked. Check that the PT does not setup a bearer on a slot announced to be blind, after reception of a PT blind full slot information message. |
| TP/PT/PG/BV-03 | DPRS service M.4 Paging broadcast EN 300 175-3 [1]: 7.2.4.3 Initial state: Idle_locked. Check that the PT stays locked to an FT, based on reception of other bearer and dummy or CL-bearer position zero length PT messages. |
| TP/PT/PG/BV-data00 | DPRS service M.4 Paging broadcast EN 300 175-3 [1]: 9.1.3 Initial state: Idle_locked. Check that the IUT accepts to be paged in frame number 2, 4, 6, 10, 12 of a multiframe when fast paging is required and accepted. |

5.3.4 Advanced connection

5.3.4.1 Bearer setup procedures

| | |
|------------------------------|---|
| Test group objective: | Verify the correct implementation of Bearer setup procedures. |
|------------------------------|---|

5.3.4.1.1 MAC service and procedure concerned

| | | |
|-------------------------|--|---|
| M.5 Advanced connection | | |
| | PT initiated pilot bearer setup | EN 300 175-3 [1]: 10.5.1.3.1 |
| | FT initiated pilot bearer setup (Fast setup) | EN 300 175-3 [1]: 10.5.1.3.2 |
| | Additional bearer setup (duplex) | EN 300 175-3 [1]: 10.2.4.3, 10.5.1.3 |
| | Additional bearer setup (double simplex) | EN 300 175-3 [1]: 10.2.4.3, 10.5.1.4 |

5.3.4.1.2 CA test purposes

| | |
|----------------------------|---|
| Subgroup objective: | Limited testing that the observable capabilities of the IUT concerning the advanced connection procedures are in accordance with the static conformance requirements. |
|----------------------------|---|

| Test purposes: | |
|---------------------------|---|
| TP/PT/BS/CA-data00 | DPRS service M.5 Advanced connection EN 300 175-3 [1]: 10.5.1.3.1 Initial state: Idle_locked. Check that the IUT manages rightly the PT initiated B-field single bearer setup procedure. |
| TP/PT/BS/CA-data01 | DPRS service M.5 Advanced connection EN 300 175-3 [1]: 10.5.1.3.2 Only for IUT that supports Fast Setup service. Initial state: Idle_locked. Check that the IUT manages rightly the FT initiated B-field single bearer fast setup procedure. |
| TP/PT/BS/CA-data02 | DPRS service M.5 Advanced connection EN 300 175-3 [1]: 10.5.1.3 Initial state: Idle_locked. Check that the IUT manages rightly a B-field duplex bearer setup procedure for additional bearers of a symmetric multibearer connection. |
| TP/PT/BS/CA-data03 | DPRS service M.5 Advanced connection EN 300 175-3 [1]: 10.5.1.4 Only for IUT that supports asymmetric connection. Initial state: Idle_locked. Check that the IUT is able to handle double simplex bearer setup procedure, initiated by the tester for additional bearers of an asymmetric multibearer connection. |

5.3.4.2 Connection modification procedures

| | |
|------------------------------|--|
| Test group objective: | Verify the correct implementation of connection modification procedures. |
|------------------------------|--|

5.3.4.2.1 MAC service and procedure concerned

| | | |
|-------------------------|-------------------------|------------------------|
| M.5 Advanced connection | | |
| | Connection modification | EN 300 175-7 [3]: 10.3 |

5.3.4.2.2 CA test purposes

| | |
|----------------------------|---|
| Subgroup objective: | Limited testing that the observable capabilities of the IUT concerning the connection modification procedures are in accordance with the static conformance requirements. |
|----------------------------|---|

| Test purposes: | |
|---------------------------|--|
| TP/PT/CM/CA-data00 | DPRS service M.5 Advanced connection EN 300 175-3 [1]: 10.3 Initial state: Active_locked. Verify that the IUT is able to handle correctly a connection modification changing the number of bearers used in a symmetric multibearer connection. |
| TP/PT/CM/CA-data01 | DPRS service M.5 Advanced connection EN 300 175-3 [1]: 10.3 Only for IUT that supports asymmetric connection. Initial state: Active_locked. Verify that the IUT is able to handle correctly a connection modification changing the number of bearers used in an asymmetric multibearer connection. |
| TP/PT/CM/CA-data01 | DPRS service M.5 Advanced connection EN 300 175-3 [1]: 10.3 Only for IUT that supports asymmetric connection. Initial state: Active_locked. Verify that the IUT is able to handle correctly a connection modification changing the number of bearers used in an asymmetric multibearer connection. |

5.3.4.3 Bearer release procedures

| | |
|------------------------------|---|
| Test group objective: | Verify the correct implementation of bearer release procedures. |
|------------------------------|---|

5.3.4.3.1 MAC service and procedure concerned

| | | |
|-------------------------|---------------------------------|----------------------------|
| M.5 Advanced connection | | |
| | Unacknowledged bearer release | EN 300 175-3 [1]: 10.7.2.1 |
| | Acknowledged bearer release | EN 300 175-3 [1]: 10.7.2.2 |
| | Bandwidth reversal fast release | EN 300 175-3 [1]: 10.7.2.3 |

5.3.4.3.2 CA test purposes

| | |
|----------------------------|--|
| Subgroup objective: | Limited testing that the observable capabilities of the IUT concerning the bearer release procedures are in accordance with the static conformance requirements. |
|----------------------------|--|

| Test purposes: | |
|---------------------------|---|
| TP/PT/BR/CA-data00 | DPRS service M.5 Advanced connection EN 300 175-3 [1]: 10.7.2.1 Initial state: Active_locked. Check that the IUT manages rightly the release of an advanced duplex bearer with an unacknowledge release procedure when receiving a release message. |
| TP/PT/BR/CA-data01 | DPRS service M.5 Advanced connection EN 300 175-3 [1]: 10.7.2.2 Only for IUT that supports asymmetric connection. Initial state: Active_locked. Check that the IUT manages rightly the release of a double simplex bearer with an acknowledge release procedure when receiving a release message. |
| TP/PT/BR/CA-data02 | DPRS service M.5 Advanced connection EN 300 175-3 [1]: 10.4 Initial state: Active_locked. Check that the IUT manages rightly a release of a multibearer connection requested by the DLC layer, by releasing all active bearers. |
| TP/PT/BR/CA-data03 | DPRS service M.5 Advanced connection EN 300 175-3 [1]: 10.7.2.3 Initial state: Active_locked. Verify that the IUT is able to handle correctly a connection modification reversing the direction of an asymmetric multibearer connection. |

5.3.4.4 Bearer handover procedures

| | |
|------------------------------|--|
| Test group objective: | Verify the correct implementation of bearer handover procedures. |
|------------------------------|--|

5.3.4.4.1 MAC service and procedure concerned

| | | |
|----------------------|-------------------------|------------------------------------|
| M.17 Bearer handover | | |
| | Bearer handover request | EN 300 175-3 [1]: 10.6.2, 10.5.1.1 |

5.3.4.4.2 CA test purposes

| | |
|----------------------------|---|
| Subgroup objective: | Limited testing that the observable capabilities of the IUT concerning the bearer handover procedures are in accordance with the static conformance requirements. |
|----------------------------|---|

| | |
|-----------------------|---|
| Test purposes: | |
| TP/PT/BH/CA-01 | DPRS service M.17 Bearer handover EN 300 175-3 [1]: 10.6 Initial state: Active_locked. Check that the IUT, for a duplex bearer, correctly initiates and completes an intercell bearer handover procedure using basic set-up. |

5.3.4.5 Connection handover procedures

| | |
|------------------------------|---|
| Test group objective: | Verify the correct implementation of bearer release procedures. |
|------------------------------|---|

5.3.4.5.1 MAC service and procedure concerned

| | | |
|--------------------------|------------------------------|--|
| M.18 Connection handover | | |
| | Advanced connection handover | EN 300 175-3 [1]: 10.2.4.3, 10.5.1.3.1 |

5.3.4.5.2 Test purposes

The behaviour of the connection handover procedures of the MAC layer of the IUT is tested at the NWK layer level of the test specification (EN 301 469-7 [10]).

5.3.5 C-plane higher layer signalling

| | |
|------------------------------|--|
| Test group objective: | Verify the correct implementation of C-plane higher layer signalling procedures. |
|------------------------------|--|

5.3.5.1 MAC service and procedure concerned

| | | |
|---|-----------------------------|------------------------------------|
| M.9 C _S higher layer signalling | | |
| | C _S channel data | EN 300 175-3 [1]: 10.8.1, 10.8.1.1 |
| M.10 C _F higher layer signalling | | |
| | C _F channel data | EN 300 175-3 [1]: 10.8.1, 10.8.1.2 |

5.3.5.2 CA test purposes

| | |
|----------------------------|---|
| Subgroup objective: | Limited testing that the observable capabilities of the IUT concerning the C-plane higher layer signalling procedures are in accordance with the static conformance requirements. |
|----------------------------|---|

| Test purposes: | |
|---------------------------|--|
| TP/PT/DT/CA-00 | DPRS service M.9 C _S higher layer signalling EN 300 175-3 [1]: 10.8.1.1 Initial state: Active_locked. Check that the IUT re-transmits C _S segment until it receives an acknowledgement in the same Automatic Repeat Request (ARQ) window. |
| TP/PT/DT/CA-01 | DPRS service M.9 C _S higher layer signalling EN 300 175-3 [1]: 10.8.1.1 Initial state: Active_locked. Check that the IUT does not transmit another C _S segment until the successful transmission of the current segment. |
| TP/PT/DT/CA-02 | DPRS service M.9 C _S higher layer signalling EN 300 175-3 [1]: 10.8.1.1 Initial state: Active_locked. Check that the IUT manages correctly the one bit numbering of the C _S segments. |
| TP/PT/DT/CA-data00 | DPRS service M.10 C _S higher layer signalling EN 300 175-3 [1]: 10.8.1.2 Only for IUT that supports C _F channel. Initial state: Active_locked. Check that the IUT re-transmits a set of C _F segment until it receives an acknowledgement in the same Automatic Repeat Request (ARQ) window. |
| TP/PT/DT/CA-data01 | DPRS service M.10 C _S higher layer signalling EN 300 175-3 [1]: 10.8.1.2 Only for IUT that supports C _F channel. Initial state: Active_locked. Check that the IUT does not transmit another set of C _F segment until the successful transmission of the current set. |
| TP/PT/DT/CA-data02 | DPRS service M.10 C _S higher layer signalling EN 300 175-3 [1]: 10.8.1.2 Only for IUT that supports C _F channel. Initial state: Active_locked. Check that the IUT manages correctly the one bit numbering of the set of C _F segments. |

5.3.6 U-plane services

| | |
|------------------------------|--|
| Test group objective: | Verify the correct implementation of U-plane procedures. |
|------------------------------|--|

5.3.6.1 MAC service and procedure concerned

| | | |
|--|---|---|
| M.6 I _P -error-detection service | | |
| | I _P -error-detect mode | EN 301 649 [4]: 10.9.1 |
| M.7 I _P -error-correction service | | |
| | I _P -error-correct mode | EN 301 649 [4]: 10.9.2 |
| | Unilateral jump | EN 301 649 [4]: D.1.4 |
| | Bearer reset | EN 300 175-3 [1]: 10.8.2.5.3 |
| M.8 U-plane point-to-multipoint service | | |
| | Connectionless S _I _P mode | EN 301 649 [4]: D.1.1 |
| M.16 Bearer replacement | | |
| | Bearer replacement | EN 300 175-3 [1]: 10.8.2.5.1, EN 301 649 [4]: D.1.5 |

5.3.6.2 CA test purposes

| | |
|----------------------------|---|
| Subgroup objective: | Limited testing that the observable capabilities of the IUT concerning the U-plane procedures are in accordance with the static conformance requirements. |
|----------------------------|---|

| Test purposes: | |
|---------------------------|--|
| TP/PT/UP/CA-data00 | DPRS service M.6 I _P -error-detection EN 301 649 [4]: 10.13.1 Initial state: Active_locked. Verify that the IUT is able to receive I _P -error-detect data for a symmetric connection. |
| TP/PT/UP/CA-data01 | DPRS service M.6 I _P -error-detection EN 301 649 [4]: 10.13.1 Only for IUT that supports asymmetric connection. Initial state: Active_locked. Verify that the IUT is able to receive I _P -error-detect data for an asymmetric connection. |
| TP/PT/UP/CA-data02 | DPRS service M.7 I _P -error-correction EN 301 649 [4]: 10.13.1 Only for IUT that supports I _P -error-correct service. Initial state: Active_locked. Verify that the IUT is able to receive I _P -error-correct data for a symmetric connection and react with the correct settings of BCK and Q2 bits. |
| TP/PT/UP/CA-data03 | DPRS service M.7 I _P -error-correction EN 301 649 [4]: 10.13.1 Only for IUT that supports I _P -error-correct service. Initial state: Active_locked. Verify that the IUT is able to receive I _P -error-correct data for an asymmetric connection and react with the correct MAC-mod2-ACK message. |
| TP/PT/UP/CA-data04 | DPRS service M.7 I _P -error-correction EN 300 175-3 [1]: 10.8.5.3 Only for IUT that supports I _P -error-correct service. Initial state: Active_locked. Check that the IUT manages rightly the MAC I _P bearer reset procedure. |
| TP/PT/UP/CA-data05 | DPRS service M.16 Bearer replacement EN 300 175-3 [1]: 10.8.2.5.1; EN 301 649 [4]: D.1.5 Initial state: Active_locked. Check that the IUT manages rightly the bearer replacement procedure. |

5.3.6.3 BI test purposes

| | |
|----------------------------|---|
| Subgroup objective: | To check the behaviour of the of the IUT in response to invalid messages. |
|----------------------------|---|

| Test purposes: | |
|---------------------------|--|
| TP/PT/UP/BI-data00 | DPRS service M.7 I _p _error_correction EN 300 175-3 [1]: 10.8.2.4.1 Only for IUT that supports I _p _error_correct service. Initial state: Active_locked. Check that the IUT, when receiving I _p _error_correction data on a duplex bearer, is capable of detecting A-field R-CRC error and to respond with the correct Q2 bit setting (Q2 = 0). |
| TP/PT/UP/BI-data01 | DPRS service M.7 I _p _error_correction EN 300 175-3 [1]: 10.8.2.4.1 Only for IUT that supports I _p _error_correct service. Initial state: Active_locked. Check that the IUT, when receiving I _p _error_correction data on an asymmetric double simplex bearer, is capable of detecting A-field R-CRC error and to respond with the correct ACK bit setting indicating the packet number of the last correctly received I _p packet. |

5.3.7 Encryption

| | |
|------------------------------|---|
| Test group objective: | Verify the correct implementation of encryption procedures. |
|------------------------------|---|

5.3.7.1 MAC service and procedure concerned

| | | |
|------------------------------|---|--------------------------------|
| M.11 Encryption activation | | |
| | Encryption process - initialization and synchronization | EN 300 175-7 [3]: 6.4.4, 6.4.5 |
| | Encryption mode control | EN 300 175-7 [3]: 6.4.6 |
| | PT Encryption activation | EN 300 175-7 [3]: 6.4.6.3 |
| | Encryption handover control | EN 300 175-7 [3]: 6.4.7 |
| M.12 Encryption deactivation | | |
| | PT Encryption deactivation | EN 300 175-7 [3]: 6.4.6.4 |

5.3.7.2 CA test purposes

| | |
|----------------------------|--|
| Subgroup objective: | Limited testing that the observable capabilities of the IUT concerning the encryption procedures are in accordance with the static conformance requirements. |
|----------------------------|--|

| Test purposes: | |
|---------------------------|---|
| TP/PT/EN/CA-data00 | DPRS service M.11 Encryption activation EN 300 175-7 [3]: 6.4 Only for IUT supporting encryption. Initial state: Active_locked. Check that the IUT manages correctly the procedure to switch an advanced connection from clear mode to encrypt mode. |
| TP/PT/EN/CA-data01 | DPRS service M.12 Encryption deactivation EN 300 175-7 [3]: 6.4 Only for IUT supporting encryption deactivation. Initial state: Active_locked. Check that the IUT manages correctly the procedure to switch an advanced connection from encrypt mode to clear mode. |

5.3.8 MAC layer management

| | |
|------------------------------|--|
| Test group objective: | Verify the correct implementation of the LLME MAC layer management procedures. |
|------------------------------|--|

5.3.8.1 MAC service and procedure concerned

| | | |
|---------------------------------|-----------------------------------|--------------------------------|
| M.2 Non continuous broadcast | | |
| | Extended system information | EN 300 175-3 [1]: 11.2 |
| M.13 Quality control | | |
| | RFPI handshake | EN 300 175-3 [1]: 11.5.1 |
| | PT frequency correction procedure | EN 300 175-3 [1]: 11.5.2.2 |
| M.14 Physical channel selection | | |
| | Physical channel selection | EN 300 175-3 [1]: 11.4, 10.5.2 |

5.3.8.2 CA test purposes

| | |
|----------------------------|---|
| Subgroup objective: | Limited testing that the observable capabilities of the IUT concerning the LLME MAC layer management procedures are in accordance with the static conformance requirements. |
|----------------------------|---|

| Test purposes: | |
|---------------------------|---|
| TP/PT/LM/CA-data00 | DPRS service M.13 Quality control. EN 300 175-3 [1]: 10.5.1.1 - 11.5.1 Initial state: Active_locked. Check that the IUT releases a bearer if it has not received the correct RFPI on that bearer in the last T201 seconds during the time an advanced connection exists. |
| TP/PT/LM/CA-data01 | DPRS service M.13 Quality control. EN 301 649 [4]: 9.4.2.5 Initial state: Active_locked. Check that the IUT releases a suspended connection after T910, if there has not been any successful handshake. |
| TP/PT/LM/CA-data02 | DPRS service M.13 Quality control. EN 301 649 [4]: 9.3.1.2.2 Initial state: Active_locked. Check that the IUT requests a suspension of a connection if no U-plane PDU or C-plane message has been transmitted or received during a consecutive period of T903. |
| TP/PT/LM/CA-data03 | DPRS service M.13 Quality control. EN 301 649 [4]: 9.3.1.2.3 Initial state: Active_locked. Check that the IUT requests a suspension of a connection if the situation of violation of the "minimum number of bearers" of the connection, exists for more time than T906. |
| TP/PT/LM/CA-data04 | DPRS service M.13 Quality control. EN 301 649 [4]: 9.3.1.2.4 Initial state: Active_locked. Check that the IUT requests a suspension of a connection if all received bearers of the connection are lost, and this situation exists for more time than T908. |
| TP/PT/LM/CA-data05 | DPRS service M.13 Quality control. EN 301 649 [4]: 9.3.1.3 Only for IUT that supports fast setup service. Initial state: Active_locked. Check that the IUT accepts a fast setup for a suspended connection at (T909 minus 10 %) after the suspend procedure. |
| TP/PT/LM/CA-data06 | DPRS service M.13 Quality control. EN 301 649 [4]: A.1.2.2.2 Initial state: Active_locked. Check that the IUT initiates a new attempt of the connection setup procedure between at minimum T904 and at maximum (T904 + T905) after the FP refuse for the first time a PT initiated connection setup. |

Bibliography

The following material, though not specifically referenced in the body of the present document (or not publicly available), gives supporting information.

ETSI EN 300 175-1: "Digital Enhanced Cordless Telecommunications (DECT); Common Interface (CI); Part 1: Overview".

ETSI EN 300 175-2: "Digital Enhanced Cordless Telecommunications (DECT); Common Interface (CI); Part 2: Physical Layer (PHL)".

ETSI EN 300 175-4: "Digital Enhanced Cordless Telecommunications (DECT); Common Interface (CI); Part 4: Data Link Control (DLC) Layer".

ETSI EN 300 175-5: "Digital Enhanced Cordless Telecommunications (DECT); Common Interface (CI); Part 5: Network (NWK) Layer".

ETSI EN 300 175-8: "Digital Enhanced Cordless Telecommunications (DECT); Common Interface (CI); Part 8: Speech Coding and Transmission".

ETSI EN 300 435: "Digital Enhanced Cordless Telecommunications (DECT); Data Services Profile (DSP); Base standard including interworking to connectionless networks (service types A and B, class 1)".

ETSI EN 300 651: "Digital Enhanced Cordless Telecommunications (DECT); Data Services Profile (DSP); Generic data link service (service type C, class 2)".

ETSI ETS 300 699: "Digital Enhanced Cordless Telecommunications (DECT); Data Services Profile (DSP); Generic data link service for closed user groups (service type C, class 1)".

ETSI EN 300 701: "Digital Enhanced Cordless Telecommunications (DECT); Data Services Profile (DSP); Generic frame relay service with mobility (service types A and B, class 2)".

ETSI ETS 300 755: "Digital Enhanced Cordless Telecommunications (DECT); Data Services Profile (DSP); Multimedia Messaging Service (MMS) with specific provision for facsimile services (service type F, class 2)".

ETSI ETS 300 757: "Digital Enhanced Cordless Telecommunications (DECT); Data Services Profile (DSP); Low rate messaging service (service type E, class 2)".

ETSI EN 301 240: "Digital Enhanced Cordless Telecommunications (DECT); Data Services Profile (DSP); Point-to-Point Protocol (PPP) interworking for internet access and general multi-protocol datagram transport".

History

| Document history | | | |
|-------------------------|---------------|----------------|--------------------------------------|
| V0.0.2 | November 1999 | Public Enquiry | PE 200012: 1999-11-24 to 2000-03-24 |
| V0.0.3 | August 2000 | Vote | V 20001013: 2000-08-14 to 2000-10-13 |
| | | | |
| | | | |
| | | | |