

Draft **ETSI EN 301 466** V1.1.1 (1999-12)

---

*European Standard (Telecommunications series)*

**Electromagnetic compatibility and  
Radio spectrum Matters (ERM);  
Technical characteristics and methods of measurement  
for two-way VHF radiotelephone apparatus  
for fixed installation in survival craft**

---



---

**Reference**DEN/ERM-RP01-015

---

---

**Keywords**emergency, GMDSS, maritime, radio, VHF

---

**ETSI**

---

**Postal address**F-06921 Sophia Antipolis Cedex - FRANCE

---

---

**Office address**

650 Route des Lucioles - Sophia Antipolis  
Valbonne - FRANCE  
Tel.: +33 4 92 94 42 00 Fax: +33 4 93 65 47 16  
Siret N° 348 623 562 00017 - NAF 742 C  
Association à but non lucratif enregistrée à la  
Sous-Préfecture de Grasse (06) N° 7803/88

---

**Internet**

secretariat@etsi.fr  
Individual copies of this ETSI deliverable  
can be downloaded from  
<http://www.etsi.org>  
If you find errors in the present document, send your  
comment to: editor@etsi.fr

---

**Important notice**

---

This ETSI deliverable may be made available in more than one electronic version or in print. In any case of existing or perceived difference in contents between such versions, the reference version is the Portable Document Format (PDF). In case of dispute, the reference shall be the printing on ETSI printers of the PDF version kept on a specific network drive within ETSI Secretariat.

---

**Copyright Notification**

---

No part may be reproduced except as authorized by written permission.  
The copyright and the foregoing restriction extend to reproduction in all media.

© European Telecommunications Standards Institute 1999.  
All rights reserved.

# Contents

Intellectual Property Rights .....	8
Foreword.....	8
1 Scope .....	9
2 References .....	9
3 Definitions, symbols and abbreviations .....	10
3.1 Definitions .....	10
3.2 Symbols .....	10
3.3 Abbreviations .....	10
4 General requirements .....	10
4.1 Construction .....	10
4.2 Frequencies and power .....	11
4.3 Controls .....	11
4.4 Switching time .....	12
4.5 Safety precautions .....	12
4.6 Class of emission and modulation characteristics.....	12
4.7 Battery .....	12
4.8 Labelling.....	12
5 Test conditions, power sources and ambient temperatures.....	13
5.1 Normal and extreme test conditions .....	13
5.2 Test power source.....	13
5.3 Normal test conditions.....	13
5.3.1 Normal temperature and humidity .....	13
5.3.2 Normal power sources .....	13
5.3.2.1 External battery power source.....	13
5.3.2.2 Integrated battery power source .....	13
5.4 Extreme test conditions .....	14
5.4.1 Extreme temperatures .....	14
5.4.1.1 Upper extreme temperature .....	14
5.4.1.2 Lower extreme temperature.....	14
5.4.2 Extreme test power supply values.....	14
5.4.2.1 Upper extreme test voltage.....	14
5.4.2.1.1 External battery power source .....	14
5.4.2.1.2 Internal battery power source .....	14
5.4.2.2 Lower extreme test voltage .....	14
5.4.2.2.1 External battery power source .....	14
5.4.2.2.2 Internal battery power source .....	14
5.5 Procedure for tests at extreme temperatures .....	15
6 General conditions of measurement.....	15
6.1 Test connections .....	15
6.2 Arrangements for test signals applied to the receiver input .....	15
6.3 Receiver mute or squelch facility .....	15
6.4 Normal test modulation .....	15
6.5 Artificial antenna .....	15
6.6 Test channels .....	16
6.7 Measurement uncertainty and interpretation of the measuring results.....	16
6.7.1 Measurement uncertainty .....	16
6.7.2 Interpretation of the measurement results .....	16
7 Environmental tests .....	17
7.1 Introduction .....	17
7.2 Procedure.....	17
7.3 Performance check .....	17

7.4	Vibration test .....	17
7.4.1	Definition .....	17
7.4.2	Method of measurement.....	17
7.4.3	Requirement.....	18
7.5	Shock tests .....	18
7.5.1	Definition .....	18
7.5.2	Method of measurement.....	18
7.5.3	Requirement.....	18
7.6	Temperature tests .....	19
7.6.1	General.....	19
7.6.2	Dry heat cycle .....	19
7.6.2.1	Method of measurement .....	19
7.6.2.2	Requirement .....	19
7.6.3	Damp heat cycle.....	19
7.6.3.1	Method of measurement .....	19
7.6.3.2	Requirement .....	19
7.6.4	Low temperature cycle.....	20
7.6.4.1	Method of measurement .....	20
7.6.4.2	Requirement .....	20
7.7	Corrosion test .....	20
7.7.1	General.....	20
7.7.2	Method of measurement.....	20
7.7.3	Requirements .....	21
7.8	Immersion test .....	21
7.8.1	Method of measurement.....	21
7.8.2	Requirements .....	21
7.9	Thermal shock .....	21
7.9.1	Method of measurement.....	21
7.9.2	Requirements .....	22
7.10	Oil resistance test.....	22
7.10.1	Method of measurement.....	22
7.10.2	Requirement.....	22
8	Transmitter .....	22
8.1	Frequency error .....	22
8.1.1	Definition.....	22
8.1.2	Method of measurement.....	22
8.1.3	Limit .....	23
8.2	Carrier power.....	23
8.2.1	Definitions .....	23
8.2.2	Method of measurement.....	23
8.2.3	Limits.....	23
8.3	Frequency deviation .....	23
8.3.1	Definition.....	23
8.3.2	Maximum frequency deviation .....	23
8.3.2.1	Method of measurement .....	23
8.3.2.2	Limit.....	23
8.3.3	Reduction of frequency deviation at modulation frequencies above 3 kHz .....	24
8.3.3.1	Method of measurement .....	24
8.3.3.2	Limits .....	24
8.4	Sensitivity of the modulator, including microphone .....	24
8.4.1	Definition.....	24
8.4.2	Method of measurement.....	24
8.4.3	Limit .....	25
8.5	Audio frequency response .....	25
8.5.1	Definition.....	25
8.5.2	Method of measurement.....	25
8.5.3	Limit .....	25
8.6	Audio frequency harmonic distortion of the emission .....	25
8.6.1	Definition.....	25
8.6.2	Method of measurement.....	25

8.6.2.1	Normal test conditions .....	25
8.6.2.2	Extreme test conditions .....	25
8.6.3	Limit .....	25
8.7	Adjacent channel power .....	26
8.7.1	Definition .....	26
8.7.2	Method of measurement.....	26
8.7.3	Limit .....	26
8.8	Conducted spurious emissions conveyed to the antenna .....	26
8.8.1	Definition.....	26
8.8.2	Method of measurement.....	27
8.8.3	Limit .....	27
8.9	Cabinet radiation and conducted spurious emissions other than those conveyed to the antenna .....	27
8.9.1	Definitions .....	27
8.9.2	Method of measurement.....	27
8.9.3	Limits.....	28
8.10	Residual modulation of the transmitter.....	28
8.10.1	Definition.....	28
8.10.2	Method of measurement.....	28
8.10.3	Limit .....	28
8.11	Transient frequency behaviour of the transmitter .....	29
8.11.1	Definitions .....	29
8.11.2	Method of measurement.....	29
8.11.3	Limits.....	30
9	Receiver.....	32
9.1	Harmonic distortion and rated audio frequency output power.....	32
9.1.1	Definition.....	32
9.1.2	Methods of measurement .....	32
9.1.3	Limits.....	32
9.2	Audio frequency response .....	32
9.2.1	Definition.....	32
9.2.2	Method of measurement.....	33
9.2.3	Limits.....	33
9.3	Maximum usable sensitivity .....	34
9.3.1	Definition.....	34
9.3.2	Method of measurement.....	34
9.3.3	Limits.....	34
9.4	Co-channel rejection.....	34
9.4.1	Definition.....	34
9.4.2	Method of measurement.....	34
9.4.3	Limit .....	35
9.5	Adjacent channel selectivity .....	35
9.5.1	Definition.....	35
9.5.2	Method of measurement.....	35
9.5.3	Limits.....	35
9.6	Spurious response rejection .....	35
9.6.1	Definition.....	35
9.6.2	Method of measurement.....	35
9.6.3	Limit .....	36
9.7	Intermodulation response .....	36
9.7.1	Definition.....	36
9.7.2	Method of measurement.....	36
9.7.3	Limit .....	36
9.8	Blocking or desensitization .....	36
9.8.1	Definition.....	36
9.8.2	Method of measurement.....	36
9.8.3	Limit .....	37
9.9	Conducted spurious emissions.....	37
9.9.1	Definition.....	37
9.9.2	Method of measurement.....	37
9.9.3	Limit .....	37

9.10	Radiated spurious emissions.....	37
9.10.1	Definition.....	37
9.10.2	Method of measurements.....	37
9.10.3	Limit.....	38
9.11	Amplitude response of the receiver limiter.....	38
9.11.1	Definition.....	38
9.11.2	Method of measurement.....	38
9.11.3	Limit.....	39
9.12	Receiver noise.....	39
9.12.1	Definition.....	39
9.12.2	Method of measurement.....	39
9.12.3	Limit.....	39
9.13	Squelch operation.....	39
9.13.1	Definition.....	39
9.13.2	Method of measurement.....	39
9.13.3	Limits.....	40
9.14	Squelch hysteresis.....	40
9.14.1	Definition.....	40
9.14.2	Method of measurement.....	40
9.14.3	Limit.....	40
10	Secondary battery charger.....	40
10.1	General.....	40
10.2	Environmental tests.....	41
10.2.1	Introduction.....	41
10.2.2	Vibration test.....	41
10.2.2.1	Definition.....	41
10.2.2.2	Method of measurement.....	41
10.2.2.3	Requirement.....	41
10.2.3	Shock tests.....	41
10.2.3.1	Definition.....	41
10.2.3.2	Method of measurement.....	42
10.2.3.3	Requirement.....	42
10.2.4	Temperature tests.....	42
10.2.4.1	General.....	42
10.2.4.2	Dry heat cycle.....	42
10.2.4.3	Damp heat cycle.....	42
10.2.4.4	Low temperature cycle.....	43
10.2.5	Corrosion test.....	43
10.2.5.1	General.....	43
10.2.5.2	Method of measurement.....	43
10.2.5.3	Requirements.....	44
10.3	Charging time.....	44
<b>Annex A (normative): Measuring receiver for adjacent channel power measurement.....</b>		<b>45</b>
A.1	Power measuring receiver specification.....	45
A.1.1	IF filter.....	45
A.1.2	Attenuation indicator.....	46
A.1.3	rms value indicator.....	46
A.1.4	Oscillator and amplifier.....	46
<b>Annex B (normative): Radiated measurements.....</b>		<b>47</b>
B.1	Test sites and general arrangements for measurements involving the use of radiated fields.....	47
B.1.1	Outdoor test site.....	47
B.1.2	Test antenna.....	48
B.1.3	Substitution antenna.....	48
B.1.4	Optional additional indoor site.....	48
B.2	Guidance on the use of radiation test sites.....	49
B.2.1	Measuring distance.....	49

B.2.2	Test antenna.....	49
B.2.3	Substitution antenna .....	49
B.2.4	Artificial antenna .....	50
B.2.5	Auxiliary cables.....	50
B.2.6	Acoustic measuring arrangement.....	50
B.3	Further optional alternative indoor test site using an anechoic chamber.....	50
B.3.1	Example of the construction of a shielded anechoic chamber .....	51
B.3.2	Influence of parasitic reflections in anechoic chambers .....	51
B.3.3	Calibration of the shielded anechoic chamber .....	52
B.4	Standard position.....	54
History	.....	55

---

## Intellectual Property Rights

IPRs essential or potentially essential to the present document may have been declared to ETSI. The information pertaining to these essential IPRs, if any, is publicly available for **ETSI members and non-members**, and can be found in SR 000 314: *"Intellectual Property Rights (IPRs); Essential, or potentially Essential, IPRs notified to ETSI in respect of ETSI standards"*, which is available from the ETSI Secretariat. Latest updates are available on the ETSI Web server (<http://www.etsi.org/ipr>).

Pursuant to the ETSI IPR Policy, no investigation, including IPR searches, has been carried out by ETSI. No guarantee can be given as to the existence of other IPRs not referenced in SR 000 314 (or the updates on the ETSI Web server) which are, or may be, or may become, essential to the present document.

---

## Foreword

This European Standard (Telecommunications series) has been produced by ETSI Technical Committee Electromagnetic compatibility and Radio spectrum Matters (ERM), and is now submitted for the Public Enquiry phase of the ETSI standards Two-step Approval Procedure.

<b>Proposed national transposition dates</b>	
Date of latest announcement of this EN (doa):	3 months after ETSI publication
Date of latest publication of new National Standard or endorsement of this EN (dop/e):	6 months after doa
Date of withdrawal of any conflicting National Standard (dow):	6 months after doa



---

# 1 Scope

The present document states the minimum technical characteristics required for VHF radiotelephone equipment, operating in the bands between 156 MHz and 174 MHz allocated to the Maritime Mobile Services and suitable for fixed installations in survival craft in accordance with the provisions of the Global Maritime Distress and Safety System (GMDSS). The relevant requirements detailed in the Radio Regulations [1], International Convention for the Safety Of Life At Sea SOLAS 1974 [6] and the International Maritime Organization Resolutions A.694 [3] (17) and A.809 [2] (19) as well as all relevant requirements of EN 60945 [9] are incorporated in the present document.

---

# 2 References

The following documents contain provisions which, through reference in this text, constitute provisions of the present document.

- References are either specific (identified by date of publication, edition number, version number, etc.) or non-specific.
- For a specific reference, subsequent revisions do not apply.
- For a non-specific reference, the latest version applies.
- A non-specific reference to an ETS shall also be taken to refer to later versions published as an EN with the same number.

- [1] Radio Regulations 1998, Appendix S-18: "Table of Transmitting Frequencies in the Band 156 - 174 MHz for Stations in the Maritime Mobile Service".
- [2] International Maritime Organization Resolution A.809 (19): "Performance standards for survival craft two way VHF radiotelephone apparatus".
- [3] International Maritime Organization Resolution A.694 (17): "General requirements for ship-borne radio equipment forming part of the Global Maritime Distress and Safety System (GMDSS)".
- [4] ETR 028: "Radio Equipment and Systems (RES); Uncertainties in the measurement of mobile radio equipment characteristics".
- [5] CCITT Recommendation P.53 (1988): "Psophometric apparatus for the objective measurement of circuit noise".
- [6] SOLAS 1974: International Convention for the Safety Of Life At Sea as amended.
- [7] IEC 68-2-27: "Basic environmental testing procedures - Part 2: Shock".
- [8] ETR 273: "Electromagnetic Compatibility and radio spectrum Matters (ERM); Improvement of radiated methods of measurement (using test sites) and evaluation of the corresponding measurement uncertainties".
- [9] EN 60945: "Maritime navigation and radiocommunication equipment and systems - General requirements, methods of testing and required test results".
- [9] ISO Recommendation 694 (1968): "Positioning of magnetic compasses in ships".

---

## 3 Definitions, symbols and abbreviations

### 3.1 Definitions

For the purposes of the present document, the following terms and definitions apply:

**modulation index:** ratio of the frequency deviation to the modulation frequency

**rated output power:** output power as defined by the manufacturer

### 3.2 Symbols

For the purposes of the present document, the following symbols apply:

dBa	Acoustic level in dB relative to $2 \times 10^{-5}$ Pascal
g	Acceleration of gravity ( $\approx 9,81$ m/s <sup>2</sup> )
G3E	Phase modulation for voice
Q	Ratio of an observed acceleration at the equipment to the acceleration at the base of the vibration table

### 3.3 Abbreviations

For the purposes of the present document, the following abbreviations apply:

ad	amplitude difference
DSC	Digital Selective Calling
emf	electro-motive force
ERP	Effective Radiated Power
EUT	Equipment under test
fd	frequency difference
GMDSS	Global Maritime Distress and Safety System
IF	Intermediate Frequency
RF	Radio Frequency
rms	root mean square
SINAD	(Signal + Noise + Distortion)/(Noise + Distortion) ratio
SOLAS	International Convention for the Safety of Life at Sea

---

## 4 General requirements

### 4.1 Construction

The equipment shall be capable of being used for on-scene communications between survival craft, between survival craft and ship and between survival craft and rescue unit..

The equipment shall comprise at least:

- a transmitter and receiver;
- an antenna which may be fixed to the equipment or mounted separately; and
- a microphone with press-to-talk switch and a loudspeaker.

The equipment shall be fitted with an external 50  $\Omega$  antenna connector.

The equipment may be operated from an external or integrated power source. An integrated power source may consist of primary or secondary batteries.

The mechanical and electrical construction and finish of the equipment shall conform in all respects to good engineering practice and the equipment shall be suitable for use in survival craft at sea.

All controls shall be of sufficient size to enable the usual control functions to be easily performed by a user wearing gloves for immersion suits, in accordance with SOLAS 1974 [6] Chapter III, Regulation 33. The number of controls should be the minimum necessary for simple and satisfactory operation.

Any parts of the equipment required to be checked during inspection or maintenance operations as laid down by the manufacturer, shall be readily accessible. Components shall be readily identifiable.

For the purpose of conformance testing in accordance with the present document, adequate technical and operational documentation shall be supplied with the equipment.

## 4.2 Frequencies and power

The equipment shall operate only on single-frequency channels for voice communications with manual control (simplex).

The equipment shall provide for transmission and reception of signals on channel 16 and at least one other single frequency channel from those specified in Appendix S-18 [1] of the Radio Regulations, (with the exception of the DSC calling channel 70).

Independent selection of transmitting and receiving frequencies shall not be possible.

After switch on the equipment shall be operational within 5 seconds.

It shall not be possible to transmit during channel switching operations.

## 4.3 Controls

The equipment shall have a channel selector and shall indicate the designator of the channel at which the equipment is set, as given in Appendix S-18 [1] of the Radio Regulations.

It shall be possible to determine that channel 16 has been selected in all ambient light conditions.

The equipment shall have the following additional controls:

- on/off switch for the equipment with a visual indication that the equipment is switched on;
- a manual non-locking push to talk switch to operate the transmitter;
- if the transmitter ERP is greater than 1 watt, a switch for reducing the power to a level not exceeding 1 watt ERP;
- an audio-frequency volume control;
- a squelch control;
- a carrier power detector giving a visual indication that the carrier is being produced.

The user shall not have access to any control which may impair the technical characteristics of the equipment if wrongly set.

## 4.4 Switching time

The channel switching arrangements shall be such that the time necessary to change over from using one of the channels to using any other channel does not exceed 5 seconds.

The time necessary to change over from transmission to reception and vice versa, shall not exceed 0,3 seconds.

## 4.5 Safety precautions

Means shall be incorporated to prevent damage to the equipment due to reversal of polarity of the battery power supply.

The equipment shall be designed to be free of sharp projections which could damage survival craft.

The equipment shall not be damaged by the effects of an open circuit or a short circuit of the antenna.

## 4.6 Class of emission and modulation characteristics

The equipment shall use phase modulation, G3E (frequency modulation with a pre-emphasis of 6 dB/octave) for speech.

The equipment shall be designed to operate satisfactorily to the requirements of the present document with a channel separation of 25 kHz.

## 4.7 Battery

Equipment with integral power supply shall be capable of operating with primary or secondary batteries.

Primary batteries shall have a shelf life of at least two years.

The capacity of integral primary battery shall be sufficient to operate the equipment continuously for at least eight hours at any temperature condition (see subclauses 5.3.1 and 5.4.1) with a 1:9 transmit to receive duty cycle at the highest rated transmit power.

This duty cycle is defined as:

- 6 s transmit at full RF output power without modulation, 6 s reception with an RF input signal at the nominal frequency of the receiver at a level of +60 dB $\mu$ V using normal test modulation (subclause 6.4); and
- the audio volume control of the receiver set at maximum followed by 48 s reception without input signal and the squelch control operational (muted).

Provisions shall be made for replacing the battery easily without the use of special tools and without degrading the performance of the equipment (particularly water tightness after re-assembly).

If the equipment is capable of operation with secondary batteries, see clause 10.

## 4.8 Labelling

All controls and indicators shall be clearly labelled.

The equipment shall be clearly labelled with brief instructions for operation.

The equipment shall be clearly marked on the exterior with identification of the manufacturer, type designation and serial number.

The compass safe distance measured in accordance with ISO Recommendation 694 [9], shall be stated on the equipment or in the user document supplied with the equipment.

The type and designation of any integrated battery used, and the expiry date of any primary battery shall be clearly labelled.

Details of the power supply from which the equipment is intended to operate shall be clearly indicated on the equipment.

---

## 5 Test conditions, power sources and ambient temperatures

### 5.1 Normal and extreme test conditions

Conformance testing shall be made under normal test conditions and also, where stated, under extreme test conditions.

### 5.2 Test power source

During conformance testing, the equipment shall be supplied from a test power source capable of producing normal and extreme test voltages as specified in subclauses 5.3.2 and 5.4.2. The test power source shall only be used in measurements where its effect on the test results shall be negligible. For the purpose of testing the power source voltage shall be measured at the input terminals of the equipment.

During testing, the power source voltages shall be maintained within a tolerance of  $\pm 3$  % relative to the voltage level at the beginning of each test.

For equipment with integrated batteries, the test power source shall only be used in measurements where the use of the test power source is mutually agreed between manufacturer and test house. In the event of any discrepancy, results obtained using the batteries shall take precedence over results obtained using the test power source.

### 5.3 Normal test conditions

#### 5.3.1 Normal temperature and humidity

The normal temperature and humidity conditions for tests shall be a combination of temperature and humidity within the following limits:

- temperature  $+15^{\circ}\text{C}$  to  $+35^{\circ}\text{C}$ ;
- relative humidity 20 % to 75 %.

#### 5.3.2 Normal power sources

##### 5.3.2.1 External battery power source

When the equipment is designed to operate from an external battery, the normal test voltage shall be the nominal voltage of the battery (12 V, 24 V, etc.).

##### 5.3.2.2 Integrated battery power source

The normal test voltage shall be the nominal voltage of the battery as declared by the manufacturer.

## 5.4 Extreme test conditions

### 5.4.1 Extreme temperatures

#### 5.4.1.1 Upper extreme temperature

For tests at the upper extreme temperature, measurements shall be made at a temperature of +55°C.

#### 5.4.1.2 Lower extreme temperature

For tests at the lower extreme temperature, measurements shall be made at a temperature of -20°C.

### 5.4.2 Extreme test power supply values

#### 5.4.2.1 Upper extreme test voltage

##### 5.4.2.1.1 External battery power source

The upper extreme test voltage shall be 1,3 times the nominal voltage of the battery (12 V, 24 V, etc.).

##### 5.4.2.1.2 Internal battery power source

The upper extreme test voltage shall be determined in each case and shall be the voltage corresponding to the voltage that the battery gives at the upper extreme temperature at the beginning of the battery test cycle (see subclause 4.7) with a load equal to that of the equipment in the muted receive condition for receiver measurements and the transmit condition for transmitter measurements.

#### 5.4.2.2 Lower extreme test voltage

##### 5.4.2.2.1 External battery power source

The lower extreme test voltage shall be 0,9 times the nominal voltage of the battery (12 V, 24 V, etc.).

##### 5.4.2.2.2 Internal battery power source

The equipment shall be fitted with an unused primary battery and shall be placed in a climatic chamber and cooled to -20°C allowing a stabilization period of two hours. The equipment shall be activated as described in subclause 4.7 for a period of eight hours. After this period the battery voltage shall be measured during equipment transmission.

If the equipment is capable of operating with secondary batteries, it shall be fitted with a fully charged secondary battery and placed in a climatic chamber and cooled to -20°C allowing a stabilization period of two hours. After this period the battery voltage shall be measured during equipment transmission.

The lower voltage measured shall be taken as the extreme lower test voltage.

## 5.5 Procedure for tests at extreme temperatures

The equipment shall be switched off during the temperature-stabilizing periods.

Before conducting tests at the upper temperature, the equipment shall be placed in the test chamber and left until thermal equilibrium is reached. The equipment shall then be switched on for half an hour during which the transmitter shall be keyed with a duty cycle of 5 minutes transmission in the high power transmit condition, and 5 minutes reception. The equipment shall meet the requirements of the present document after this period.

For tests at the lower temperature, the equipment shall be left in the test chamber until thermal equilibrium is reached and shall then be switched to the standby or receive position for one minute, after which the equipment shall meet the requirements of the present document.

---

## 6 General conditions of measurement

### 6.1 Test connections

For the purposes of conformance testing, the manufacturer and the test house shall agree on suitable connections to test points within the equipment, which allow easy access to:

- the transmitter audio input(s);
- the receiver audio output(s);
- the push-to-talk switch.

### 6.2 Arrangements for test signals applied to the receiver input

Test signal generators shall be connected to the receiver input in such a way that the impedance presented to the receiver input is 50 $\Omega$ , irrespective of whether one or more test signals are applied to the receiver simultaneously.

The levels of the test signals shall be expressed in terms of the emf at the terminals to be connected to the receiver.

The effects of any intermodulation product and noise product in the test signal generators should be negligible.

The nominal frequency of the receiver is the carrier frequency of the selected channel.

### 6.3 Receiver mute or squelch facility

Unless otherwise specified, the receiver squelch facility shall be made inoperative for the duration of the conformance tests.

### 6.4 Normal test modulation

For normal test modulation, the modulation frequency shall be 1 kHz and the frequency deviation shall be  $\pm 3$  kHz.

### 6.5 Artificial antenna

When tests are conducted with an artificial antenna, this shall be a 50  $\Omega$  non-reactive, non-radiating load.

## 6.6 Test channels

Conformance testing shall be made on channel 16 unless otherwise stated.

## 6.7 Measurement uncertainty and interpretation of the measuring results

### 6.7.1 Measurement uncertainty

Absolute measurement uncertainties: maximum values:

- RF frequency:  $\pm 1 \times 10^{-7}$ ;
- RF power:  $\pm 0,75$  dB.

Maximum frequency deviation:

- within 300 Hz to 6 kHz of audio frequency:  $\pm 5$  %;
- within 6 kHz to 25 kHz of audio frequency:  $\pm 3$  dB.

Deviation limitation:	$\pm 5$ %
Adjacent channel power:	$\pm 5$ dB
Audio output power:	$\pm 0,5$ dB
Amplitude characteristics of receiver limiter:	$\pm 1,5$ dB
Sensitivity at 20 dB SINAD:	$\pm 3$ dB
Two signal measurement:	$\pm 4$ dB
Three signal measurement:	$\pm 3$ dB
Radiated emission of transmitter:	$\pm 6$ dB
Radiated emission of receiver:	$\pm 6$ dB
Transmitter transient time:	$\pm 20$ %
Transmitter transient frequency:	$\pm 250$ Hz

For the test methods according to the present document the uncertainty figures are valid to a confidence level of 95 % calculated according to the methods described in ETR 028 [4].

### 6.7.2 Interpretation of the measurement results

The interpretation of the results recorded in a test report for the measurements described in the present document shall be as follows:

- the measured value related to the corresponding limit will be used to decide whether an equipment meets the requirements of the present document;
- the measurement uncertainty value for the measurement of each parameter shall be included in the test report;
- the recorded value of the measurement uncertainty shall be, for each measurement, equal to or lower than the maximum values given above.



---

## 7 Environmental tests

### 7.1 Introduction

The tests in this subclause are performed in order to simulate the environment in which the equipment is intended to operate.

### 7.2 Procedure

Environmental tests shall be carried out before tests of the same equipment in respect to the other requirements of the present document are performed. The following tests shall be carried out in the order they appear in this subclause.

Unless otherwise stated, the equipment shall be connected to an electrical power source only during the periods for which it is specified that electrical tests shall be carried out. These shall be done with normal test voltage.

### 7.3 Performance check

The performance check shall be a check of transmitter frequency error (see subclause 8.1.1), transmitter carrier power (see subclause 8.2.1) and maximum usable sensitivity of the receiver (see subclause 9.3.1):

- The transmitter carrier frequency shall be measured on channel 16 in the absence of modulation with the transmitter connected to an artificial antenna (see subclause 6.4). The test shall be carried out with output switch set in the maximum position. The frequency error shall be within  $\pm 1,5$  kHz.
- The transmitter carrier power shall be measured on channel 16 with the transmitter connected to the artificial antenna (see subclause 6.5). The test shall be carried out with the output switch set in the maximum position. The carrier power shall be between 0,25 W and 25 W.
- The maximum usable sensitivity of the receiver shall be measured on channel 16. A test signal modulated by the normal test modulation (see subclause 6.3) shall be applied to the receiver input. An audio frequency load and an instrument for measuring SINAD ratio (through a psophometric filter as specified in subclause 9.3.2) shall be connected to the receiver output terminals. The level of the test signal shall be adjusted until a SINAD ratio of 20 dB is obtained and with the receiver's audio frequency power control adjusted to produce at least 50 % of the rated output power. The level of the test signal shall not exceed +12 dB $\mu$ V (emf).

### 7.4 Vibration test

#### 7.4.1 Definition

This test determines the ability of equipment to withstand vibration without resulting in mechanical weakness or degradation in performance.

#### 7.4.2 Method of measurement

The EUT, complete with any shock and vibration absorbers with which it is provided, shall be clamped to the vibration table by its normal means of support and in its normal attitude. The EUT may be resiliently suspended to compensate for weight not capable of being withstood by the vibration table. Provision may be made to reduce or nullify any adverse effect on EUT performance which could be caused by the presence of an electro-magnetic field due to the vibration unit.

The EUT shall be subjected to sinusoidal vertical vibration at all frequencies between:

- 5 Hz and up to 13,2 Hz with an excursion of  $\pm 1$  mm  $\pm 10$  % (7 m/s<sup>2</sup> maximum acceleration at 13,2 Hz);
- above 13,2 Hz and up to 100 Hz with a constant maximum acceleration of 7 m/s<sup>2</sup>.

The frequency sweep rate shall be slow enough to allow the detection of resonances in any part of the EUT.

A resonance search shall be carried out throughout the test. If any resonance of the EUT has  $Q \geq 5$  measured relative to the base of the vibration table, the EUT shall be subjected to a further vibration endurance test at each resonant frequency at the vibration level specified in the test with a duration of two hours. If any resonance with  $Q < 5$  occurs the further endurance test shall be carried out at one single observed frequency. If no resonance occurred, the further endurance test shall be carried out at a frequency of 30 Hz.

Performance check(s) shall be carried out at the end of each two hour endurance test period.

The procedure shall be repeated with vibration in each of two mutually perpendicular directions in the horizontal plane.

After conducting the vibration tests, the equipment shall be inspected for any mechanical deterioration.

### 7.4.3 Requirement

The equipment shall meet the requirements of the performance check.

There shall be no harmful deterioration of the equipment visible.

## 7.5 Shock tests

### 7.5.1 Definition

This test determines the ability of equipment to withstand mechanical shock.

### 7.5.2 Method of measurement

The EUT, complete with any shock and vibration absorbers with which it is provided, shall be clamped to the table of the shock testing machine by its normal means of support and in its normal attitude.

The shock applied to the equipment shall consist of a pulse being one half-cycle of a sine wave in accordance with IEC 68-2-27 [7].

The peak acceleration shall be 30 g and the duration shall be 18 ms.

Three successive shocks shall be applied in each direction of the three mutually perpendicular axes of the EUT.

After the test, the equipment shall be inspected for any mechanical deterioration and a performance check shall be carried out.

### 7.5.3 Requirement

The equipment shall meet the requirements of the performance check.

There shall be no harmful deterioration of the equipment visible.

## 7.6 Temperature tests

### 7.6.1 General

The maximum rate of raising or reducing the temperature of the chamber in which the equipment is being tested shall be 1°C/minute.

### 7.6.2 Dry heat cycle

#### 7.6.2.1 Method of measurement

The equipment shall be placed in a chamber at normal temperature. The temperature shall then be raised to, and maintained at, +70°C ( $\pm 3^\circ\text{C}$ ) for a period of at least 10 hours. After this period any climatic control device provided in the equipment may be switched on and the chamber cooled to +55°C ( $\pm 3^\circ\text{C}$ ). The cooling of the chamber shall be completed within 30 minutes.

The equipment shall then be switched on and set to maximum transmit power. The transmitter shall be keyed with a duty cycle of 5 minutes transmission and 5 minutes reception for a period of 2 hours. The equipment shall be subjected to a performance check at the end of the 2 hours period.

The temperature of the chamber shall be maintained at +55°C ( $\pm 3^\circ\text{C}$ ) during the 2 hours period.

At the end of the test, and with the equipment still in the chamber, the chamber shall be brought to room temperature in not less than 1 hour. The equipment shall then be exposed to normal room temperature and humidity for not less than 3 hours before the next test is carried out.

#### 7.6.2.2 Requirement

The requirement of the performance check shall be met.

### 7.6.3 Damp heat cycle

#### 7.6.3.1 Method of measurement

The equipment shall be placed in a chamber at normal room temperature and humidity which, steadily, over a period 3 hours ( $\pm 0,5$  hours), shall be heated from room temperature to +40°C ( $\pm 3^\circ\text{C}$ ) and shall during this period be brought to a relative humidity of 93 % ( $\pm 2$  %) so that excessive condensation is avoided.

These conditions shall be maintained for a period of at least 10 hours.

After this period, any climatic control devices provided within the equipment may be switched on.

30 minutes later the equipment shall be switched on, and set to maximum transmit power. The transmitter shall be keyed with a duty cycle of 5 minutes transmission and 5 minutes reception for a period of 2 hours. The equipment shall be subjected to a performance check at the end of the 2 hours period.

The temperature and relative humidity of the chamber shall be maintained at +40°C ( $\pm 3^\circ\text{C}$ ) and 93 % ( $\pm 2$  %) during the 2 hours 30 minutes period.

At the end of the test, and with the equipment still in the chamber, the chamber shall be brought to room temperature in not less than 1 hour. The equipment shall then be exposed to normal room temperature and humidity for not less than 3 hours, or until moisture has dispersed, whichever is longer, before the next test is carried out.

#### 7.6.3.2 Requirement

The requirement of the performance check shall be met.

## 7.6.4 Low temperature cycle

### 7.6.4.1 Method of measurement

The equipment shall be placed in a chamber at normal room temperature. Then the temperature shall be reduced to, and maintained at  $-30^{\circ}\text{C}$  ( $\pm 3^{\circ}\text{C}$ ) for a period of at least 10 hours.

Any climatic devices provided within the equipment may then be switched on and the chamber shall be warmed to  $-20^{\circ}\text{C}$  ( $\pm 3^{\circ}\text{C}$ ). The warming of the chamber shall be completed within 30 minutes ( $\pm 5$  minutes).

The equipment shall then be switched on in the receiver mode and the temperature of the chamber shall be maintained at  $-20^{\circ}\text{C}$  ( $\pm 3^{\circ}\text{C}$ ) during a period of 90 minutes.

The equipment shall be subjected to a performance check at the end of the last 30 minutes of the test.

At the end of the test, and with the equipment still in the chamber, the chamber shall be brought to room temperature in not less than 1 hour. The equipment shall then be exposed to normal room temperature for not less than 3 hours, or until moisture has dispersed, whichever is longer, before the next test is carried out.

### 7.6.4.2 Requirement

The requirements of the performance check shall be met.

## 7.7 Corrosion test

### 7.7.1 General

This test may be omitted if sufficient evidence is provided by the manufacturer that the corresponding requirements of this subclause are met.

### 7.7.2 Method of measurement

The equipment shall be placed in a chamber fitted with apparatus capable of spraying in the form of fine mist, such as would be produced by a spray gun, salt solution to the following formula:

- sodium chloride 26,50 grammes  $\pm 10$  %;
- magnesium chloride 2,50 grammes  $\pm 10$  %;
- magnesium sulphate 3,30 grammes  $\pm 10$  %;
- calcium chloride 1,10 grammes  $\pm 10$  %;
- potassium chloride 0,73 grammes  $\pm 10$  %;
- sodium bicarbonate 0,20 grammes  $\pm 10$  %;
- sodium bromide 0,28 grammes  $\pm 10$  %;

plus distilled water to make the solution up to 1 litre.

Alternatively a 5 % sodium chloride (NaCl) solution may be used.

The salt used for the test shall be high quality sodium chloride (NaCl) containing, when dry, not more than 0,1 % sodium iodine and not more than 0,3 % of total impurities.

Salt solution concentration shall be 5 % ( $\pm 1$  %) by weight.

The solution shall be prepared by dissolving 5 parts  $\pm 1$  by weight of salt in 95 parts weight of distilled or de-mineralized water.

The pH value of the solution shall be between 6,5 and 7,2 at temperature of 20°C ( $\pm 2^\circ\text{C}$ ). The pH value shall be maintained within this range during conditioning; for this purpose, diluted hydrochloric acid or sodium hydroxide may be used to adjust the pH value, provided that the concentration of NaCl remains within the prescribed limits. The pH value shall be measured when preparing each new batch of solution.

The spraying apparatus shall be such that the products of corrosion cannot mix with the salt solution contained within the spray reservoir.

The equipment shall be sprayed simultaneously on all its external surfaces with the salt solution for a period of 1 hour.

This spraying shall be carried out 4 times with a storage period of 7 days at 40°C ( $\pm 2^\circ\text{C}$ ) after each spraying. The relative humidity during storage shall be maintained between 90 % and 95 %. At the end of the total period the equipment shall be examined visually.

The equipment shall then be subjected to a performance check.

### 7.7.3 Requirements

There shall be no undue deterioration or corrosion of the metal parts, finishes, material or component parts visible to the naked eye.

In the case of hermetically sealed equipment there shall be no evidence of moisture penetration.

The requirements of the performance check shall be met.

## 7.8 Immersion test

### 7.8.1 Method of measurement

A hydraulic pressure of 10 kPa, corresponding to a depth of 1 metre shall be applied for a period of 5 minutes.

Within 2 minutes after the end of the test period the equipment shall be subjected to a performance check, and be inspected for damage and visible ingress of water.

Following inspection, the equipment shall be resealed in accordance with the manufacturer's instructions.

### 7.8.2 Requirements

The requirement of the performance check shall be met.

No damage or ingress of water shall be visible to the naked eye.

## 7.9 Thermal shock

### 7.9.1 Method of measurement

The equipment shall be placed in an atmosphere of +65°C ( $\pm 3^\circ\text{C}$ ) for 1 hour. It shall then be immersed in water at +20°C ( $\pm 3^\circ\text{C}$ ) to a depth of 10 cm, measured from the highest point of the equipment to the surface of the water, for a period of 1 hour.

Within 2 minutes of the end of the test period the equipment shall be subjected to a performance check, and be inspected for damage and visible ingress of water.

Following inspection, the equipment shall be resealed in accordance with the manufacturer's instructions.

## 7.9.2 Requirements

The requirement of the performance check shall be met.

No damage or ingress of water shall be visible to the naked eye.

## 7.10 Oil resistance test

This test may be omitted if sufficient evidence is provided by the manufacturer that the corresponding requirements of this subclause are met.

### 7.10.1 Method of measurement

The equipment shall be immersed at a temperature of  $+19^{\circ}\text{C}$  ( $\pm 1^{\circ}\text{C}$ ) for 3 hours in a mineral oil of the following specification:

- Aniline point:  $120^{\circ}\text{C} \pm 5^{\circ}\text{C}$ ;
- Flash point: minimum  $240^{\circ}\text{C}$ ;
- Viscosity: 10 -25 cSt at  $99^{\circ}\text{C}$ .

The following oils may be used:

- ASTM Oil No.1;
- ASTM Oil No.5;
- ISO Oil No.1.

After the test, the equipment shall be cleaned in accordance with the manufacturer's instructions.

### 7.10.2 Requirement

The requirement of the performance check shall be fulfilled.

There shall be no harmful deterioration of the equipment visible to the naked eye.

---

## 8 Transmitter

Tests on the transmitter shall be carried out with the output power switch set at its maximum except where otherwise stated.

### 8.1 Frequency error

#### 8.1.1 Definition

The frequency error is the difference between the measured carrier frequency and its nominal value.

#### 8.1.2 Method of measurement

The carrier frequency shall be measured in the absence of modulation, with the transmitter connected to an artificial antenna (see subclause 6.5). Measurements shall be made under normal test conditions (see subclause 5.3) and under extreme test conditions (subclauses 5.4.1 and 5.4.2 applied simultaneously).

### 8.1.3 Limit

The frequency error shall be within  $\pm 1,5$  kHz.

## 8.2 Carrier power

### 8.2.1 Definitions

The carrier power is the mean power delivered to the artificial antenna during one radio frequency cycle in the absence of modulation.

The rated output power is the carrier power declared by the manufacturer.

### 8.2.2 Method of measurement

The transmitter shall be connected to an artificial antenna (see subclause 6.4) and the power delivered to this artificial antenna shall be measured. The measurements shall be made under normal test conditions (see subclause 5.3) and also under extreme test conditions (subclauses 5.4.1 and 5.4.2 applied simultaneously).

### 8.2.3 Limits

The carrier power shall be between 0,25 W and 25 W with the power switch at maximum.

The carrier power shall be between 0,25 W and 1 W with the power switch at minimum.

The measured carrier power shall not vary by more than  $\pm 1,5$  dB from the rated output power under normal test conditions and by not more than +2 dB and -3 dB under extreme test conditions.

## 8.3 Frequency deviation

### 8.3.1 Definition

The frequency deviation is the difference between the instantaneous frequency of the modulated radio-frequency signal and the carrier frequency.

### 8.3.2 Maximum frequency deviation

#### 8.3.2.1 Method of measurement

The frequency deviation shall be measured at the transmitter output, with the transmitter connected to an artificial antenna (see subclause 6.5), by means of a deviation meter capable of measuring the maximum deviation, including that due to any harmonics and intermodulation products which may be generated in the transmitter.

The modulation frequency shall be varied between 100 Hz and 3 kHz. The level of this test signal shall be 20 dB above the level which produces normal test modulation (see subclause 6.4). This test shall be repeated with the output power switch set at maximum and minimum.

#### 8.3.2.2 Limit

The maximum frequency deviation shall be  $\pm 5$  kHz.

### 8.3.3 Reduction of frequency deviation at modulation frequencies above 3 kHz

#### 8.3.3.1 Method of measurement

The transmitter shall operate under normal test conditions (see subclause 5.3) connected to a load as specified in subclause 6.5. The transmitter shall be modulated by the normal test modulation (see subclause 6.4). With the input level of the modulation signal being kept constant, the modulation frequency shall be varied between 3 kHz and 25 kHz and the frequency deviation shall be measured.

#### 8.3.3.2 Limits

For modulation frequencies between 3 kHz and 6 kHz the frequency deviation shall not exceed the frequency deviation with a modulation frequency of 3 kHz. For a modulation frequency of 6 kHz, the frequency deviation shall not exceed  $\pm 1,5$  kHz.

For modulation frequencies between 6 kHz and 25 kHz, the frequency deviation shall not exceed that given by a linear response of frequency deviation (in dB) against modulation frequency, starting at the point where the modulation frequency is 6 kHz and the frequency deviation is  $\pm 1,5$  kHz and inclined at 14 dB per octave, with the frequency deviation diminishing as the modulation frequency increases as shown in figure 1.

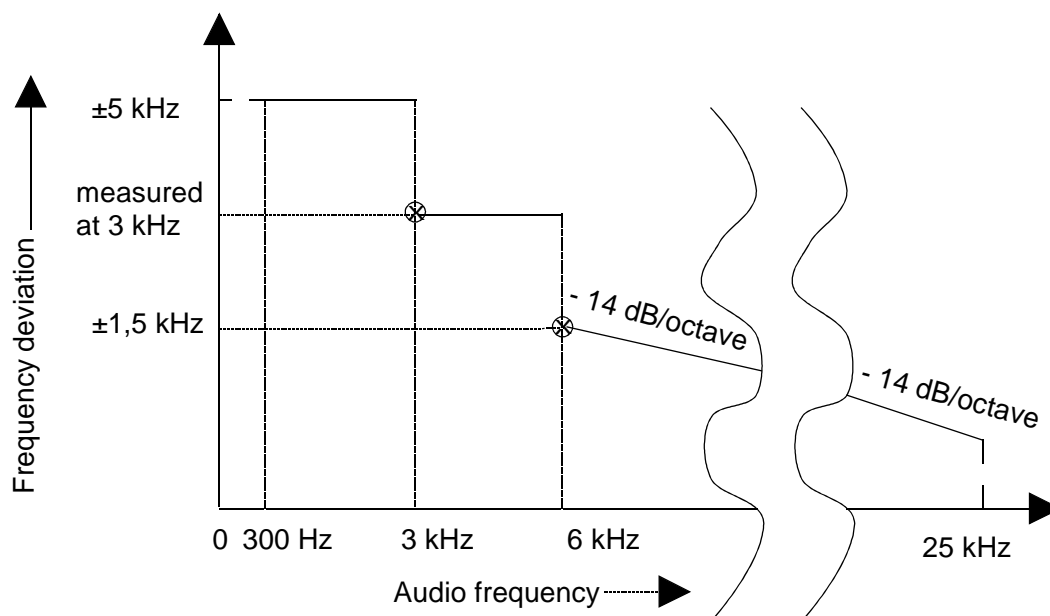

Figure 1: Frequency deviation versus audio modulation frequency

## 8.4 Sensitivity of the modulator, including microphone

### 8.4.1 Definition

This sensitivity expresses the capability of the transmitter to produce sufficient modulation when an audio frequency signal corresponding to the normal mean speech level is applied to the microphone.

### 8.4.2 Method of measurement

An acoustic signal with a frequency of 1 kHz and a sound level of 94 dB relative to  $2 \times 10^{-5}$  Pascal (94 dBA) shall be applied to the microphone. The resulting frequency deviation shall be measured.



### 8.4.3 Limit

The resulting frequency deviation shall be between  $\pm 1,5$  kHz and  $\pm 3$  kHz.

## 8.5 Audio frequency response

### 8.5.1 Definition

The audio frequency response is the frequency deviation of the transmitter as a function of the modulating frequency.

### 8.5.2 Method of measurement

A modulation signal at a frequency of 1 kHz shall be applied to the transmitter audio input. Its level shall be adjusted so that the frequency deviation is  $\pm 1$  kHz. The modulation frequency shall then be varied between 300 Hz and 3 kHz, with the level of the audio frequency signal being kept constant and equal to the value specified above.

### 8.5.3 Limit

The modulation index (ratio of the frequency deviation to the modulation frequency) shall be constant and equal to its value at 1 kHz, within the limits of +1 dB or -3 dB.

## 8.6 Audio frequency harmonic distortion of the emission

### 8.6.1 Definition

The harmonic distortion of the emission modulated by an audio frequency signal is defined as the ratio, expressed as a percentage, of the rms voltage of all the harmonic components of the fundamental frequency to the total rms voltage of the signal after linear demodulation.

### 8.6.2 Method of measurement

The radio frequency signal produced by the transmitter shall be applied via an appropriate coupling device to a linear demodulator with a de-emphasis network of 6 dB per octave.

#### 8.6.2.1 Normal test conditions

Under normal test conditions (see subclause 5.3) the radio frequency signal shall be modulated successively at frequencies of 300 Hz and 1 kHz with a constant modulation index of 3.

The distortion of the audio frequency signal shall be measured at all the frequencies specified above.

#### 8.6.2.2 Extreme test conditions

Under extreme test conditions (subclauses 5.4.1 and 5.4.2 applied simultaneously), the measurements shall be carried out at 1 kHz with a frequency deviation of  $\pm 3$  kHz.

### 8.6.3 Limit

The harmonic distortion shall not exceed 10 %.

## 8.7 Adjacent channel power

### 8.7.1 Definition

The adjacent channel power is that part of the total power output of a transmitter under defined conditions of modulation, which falls within a specified pass-band centred on the nominal frequency of either of the adjacent channels. This power is the sum of the mean power produced by the modulation, hum and noise of the transmitter.

### 8.7.2 Method of measurement

The adjacent channel power shall be measured with a power measuring receiver which conforms to the specifications in annex A (referred to in this and the following subclause as the "receiver").

- a) The output of the transmitter shall be linked to the input of the "receiver" by a connecting device such that the impedance presented to the transmitter is 50  $\Omega$  and the level at the "receiver" input is appropriate.
- b) With the transmitter un-modulated (see note), the tuning of the "receiver" shall be adjusted so that a maximum response is obtained. This is the 0 dB response point. The "receiver" attenuator setting and the reading of the meter shall be recorded.
- c) The tuning of the "receiver" shall be adjusted away from the carrier so that the "receiver" -6 dB response nearest to the transmitter carrier frequency is located at a displacement from the nominal carrier frequency of 17 kHz.
- d) The transmitter shall be modulated with 1,25 kHz at a level which is 20 dB higher than that required to produce  $\pm 3$  kHz deviation.
- e) The "receiver" variable attenuator shall be adjusted to obtain the same meter reading as in step b) or a known relation of it.
- f) The ratio of adjacent channel power to carrier power is the difference between the attenuator settings in steps b) and e), corrected for any differences in the reading of the meter.
- g) The measurement shall be repeated with the "receiver" tuned to the other side of the carrier.

NOTE: The measurement may be made with the transmitter modulated with normal test modulation, in which case this fact shall be recorded with the test results.

### 8.7.3 Limit

The adjacent channel power shall not exceed a value of 70 dB below the carrier power of the transmitter without any need to be below 0,2  $\mu$ W.

## 8.8 Conducted spurious emissions conveyed to the antenna

### 8.8.1 Definition

Conducted spurious emissions are emissions on a frequency or frequencies which are outside the necessary bandwidth and the level of which may be reduced without affecting the corresponding transmission of information. Spurious emissions include harmonic emissions, parasitic emissions, intermodulation products and frequency conversion products, but exclude out of band emissions.

## 8.8.2 Method of measurement

Conducted spurious emissions shall be measured with the unmodulated transmitter connected to the artificial antenna (see subclause 6.5).

The measurements shall be made over a range from 9 kHz to 2 GHz, excluding the channel on which the transmitter is operating and its adjacent channels.

The measurements for each spurious emission shall be made using a tuned radio measuring instrument or a spectrum analyser.

## 8.8.3 Limit

The power of any conducted spurious emission on any discrete frequency shall not exceed 0,25  $\mu$ W.

## 8.9 Cabinet radiation and conducted spurious emissions other than those conveyed to the antenna

### 8.9.1 Definitions

Cabinet radiation consists of emissions at frequencies, radiated by the equipment cabinet and structures.

Conducted spurious emissions other than those conveyed to the antenna are emissions at frequencies, other than those of the carrier and the sideband components resulting from the wanted modulation process, which are produced by conduction in the wiring and accessories used with the equipment.

### 8.9.2 Method of measurement

On a test site, selected from annex B, the equipment shall be placed at the specified height on a non-conducting support and in position closest to normal use as declared by the manufacturer.

The transmitter antenna connector shall be connected to on artificial antenna, see subclause 6.5.

The test antenna shall be orientated for vertical polarization.

The output of the test antenna shall be connected to a measuring receiver.

The transmitter shall be switched on without modulation, and measuring receiver shall be tuned over the frequency range 30 MHz to 2 GHz, except for the channel on which the transmitter is intended to operate and its adjacent channels.

At each frequency at which a spurious component is detected:

- a) the test antenna shall be raised and lowered through the specified range of heights until a maximum signal level is detected on the measuring receiver;
- b) the transmitter shall be rotated through 360° in the horizontal plane, until the maximum signal level is detected by the measuring receiver;
- c) the maximum signal level detected by the measuring receiver shall be noted;
- d) the transmitter shall be replaced by a substitution antenna as defined in annex B;
- e) the substitution antenna shall be orientated for vertical polarization and the length of the substitution antenna shall be adjusted to correspond to the frequency of the spurious component detected;
- f) the substitution antenna shall be connected to a calibrated signal generator;
- g) the frequency of the calibrated signal generator shall be set to the frequency of the spurious component detected;
- h) the input attenuator setting of the measuring receiver shall be adjusted in order to increase the sensitivity of the measuring receiver, if necessary;

- i) the test antenna shall be raised and lowered through the specified range of heights to ensure that the maximum signal is received;
- j) the input signal to the substitution antenna shall be adjusted to the level that produces a level detected by the measuring receiver that is equal to the level noted while the spurious component was measured, corrected for the change of input attenuator setting of the measuring receiver;
- k) the input level to the substitution antenna shall be recorded as power level, corrected for the change of input attenuator setting of the measuring receiver;
- l) the measurement shall be repeated with the test antenna and the substitution antenna orientated for horizontal polarization;
- m) the measure of the effective radiated power of the spurious components is larger of the two power levels recorded for spurious component at the input to the substitution antenna, corrected for the gain of the antenna if necessary;
- n) the measurements shall be repeated with the transmitter on stand-by.

### 8.9.3 Limits

When the transmitter is in stand-by the cabinet radiation and spurious emissions shall not exceed 2 nW.

When the transmitter is in operation the cabinet radiation and spurious emissions shall not exceed 0,25  $\mu$ W.

## 8.10 Residual modulation of the transmitter

### 8.10.1 Definition

The residual modulation of the transmitter is the ratio, in dB, of the demodulated RF signal in the absence of wanted modulation, to the demodulated RF signal produced when the normal test modulation is applied.

### 8.10.2 Method of measurement

The normal test modulation defined in subclause 6.4 shall be applied to the transmitter. The high frequency signal produced by the transmitter shall be applied, via an appropriate coupling device, to a linear demodulator with a de-emphasis network of 6 dB per octave. The time constant of this de-emphasis network shall be at least 750  $\mu$ s.

A high pass filter with a cut-off frequency of nominally 100 Hz shall be used to avoid the effects of emphasizing the low audio frequencies produced by internal noise.

The signal shall be measured at the demodulator output using an rms voltmeter.

The modulation shall then be switched off and the level of the residual audio-frequency signal at the output shall be measured again.

### 8.10.3 Limit

The residual modulation shall not exceed -40 dB.

## 8.11 Transient frequency behaviour of the transmitter

### 8.11.1 Definitions

The transient frequency behaviour of the transmitter is the variation in time of the transmitter frequency difference from the nominal frequency of the transmitter when the RF output power is switched on and off.

- $t_{on}$ : according to the method of measurement described in subclause 8.11.2 the switch-on instant  $t_{on}$  of a transmitter is defined by the condition when the output power, measured at the antenna terminal, exceeds 0,1 % of the nominal power;
- $t_1$ : period of time starting at  $t_{on}$  and finishing according to table 1;
- $t_2$ : period of time starting at the end of  $t_1$  and finishing according to table 1;
- $t_{off}$ : switch-off instant defined by the condition when the output power falls below 0,1 % of the nominal power;
- $t_3$ : period of time that finishing at  $t_{off}$  and starting according to table 1.

**Table 1: Limits**

$t_1$ (ms)	5,0
$t_2$ (ms)	20,0
$t_3$ (ms)	5,0

### 8.11.2 Method of measurement

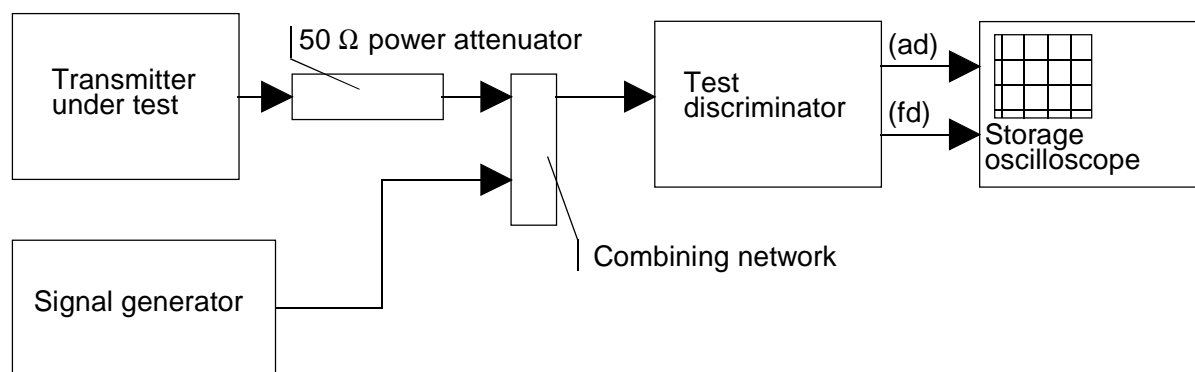

**Figure 2: Measurement arrangement**

Two signals shall be connected to the test discriminator via a combining network (see subclause 6.2).

The transmitter shall be connected to a 50 Ω power attenuator.

The output of the power attenuator shall be connected to the test discriminator via one input of the combining network.

A test signal generator shall be connected to the second input of the combining network.

The test signal shall be adjusted to the nominal frequency of the transmitter.

The test signal shall be modulated by a frequency of 1 kHz with a deviation of ±25 kHz.

The test signal level shall be adjusted to correspond to 0,1 % of the power of the transmitter under test measured at the input of the test discriminator. This level shall be maintained throughout the measurement.

The amplitude difference (ad) (see figure 2) and the frequency difference (fd) (see figure 2) output of the test discriminator shall be connected to a storage oscilloscope.

The storage oscilloscope shall be set to display the channel corresponding to the fd input up to +1 channel frequency difference, corresponding to the relevant channel separation, from the nominal frequency.

The storage oscilloscope shall be set to a sweep rate of 10 ms/division and set so that the triggering occurs at 1 division from the left edge of the display.

The display will show the 1 kHz test signal continuously.

The storage oscilloscope shall then be set to trigger on the channel corresponding to the ad input at a low input level, rising.

The transmitter shall then be switched on, without modulation, to produce the trigger pulse and a picture on the display.

The result of the change in the ratio of power between the test signal and the transmitter output will, due to the capture ratio of the test discriminator, produce two separate sides on the picture, one showing the 1 kHz test signal, the other the frequency difference of the transmitter versus time.

The moment when the 1 kHz test signal is completely suppressed is considered to provide  $t_{on}$ .

The periods of time  $t_1$  and  $t_2$  as defined in table 1 shall be used to define the appropriate template.

The result shall be recorded as frequency difference versus time.

The transmitter shall remain switched on.

The storage oscilloscope shall be set to trigger on the channel corresponding to the ad input at a high input level, decaying and set so that the triggering occurs at 1 division from the right edge of the display.

The transmitter shall then be switched off.

The moment when the 1 kHz test signal starts to rise is considered to provide  $t_{off}$ .

The period of time  $t_3$  as defined in table 1 shall be used to define the appropriate template.

The result shall be recorded as frequency difference versus time.

### 8.11.3 Limits

During the periods  $t_1$  and  $t_3$  the frequency difference shall not exceed the value of 1 channel separation. During the period  $t_2$  the frequency difference shall not exceed the value of half a channel separation (see also figure 3).

Switch on condition: limits:  $\Delta f \leq 25$  kHz during  $t_1$  (= 5 msec)  
 $\Delta f \leq 12,5$  kHz during  $t_2$  (= 20 msec)

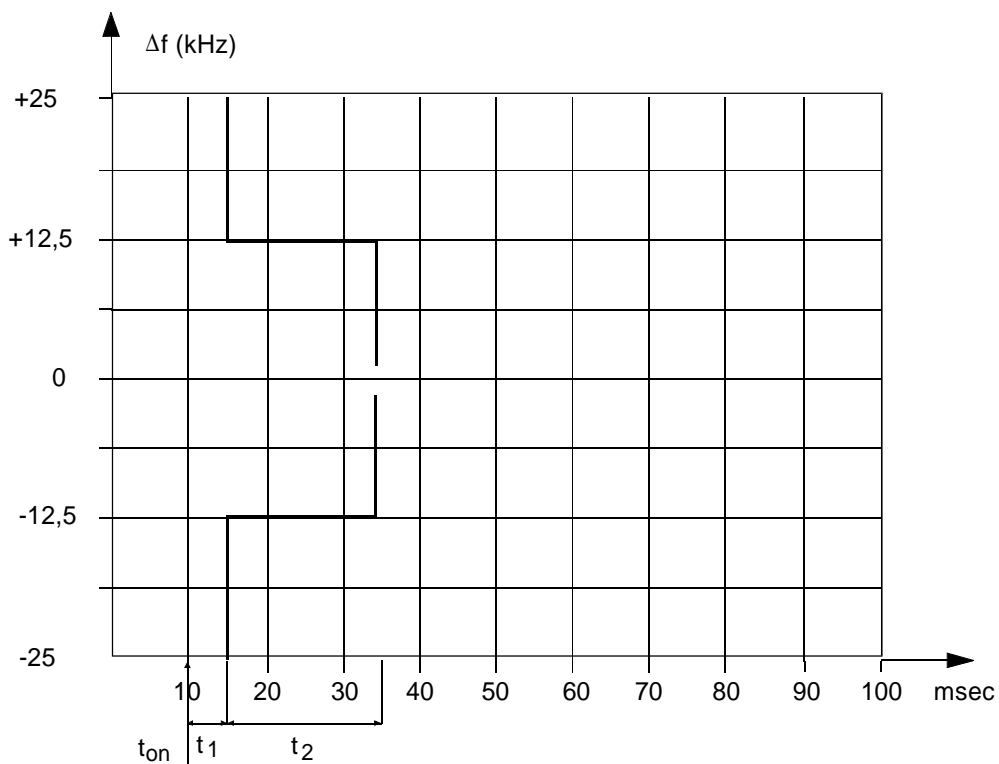

Switch off condition: limits:  $\Delta f \leq 25$  kHz during  $t_3$  (= 5 msec)

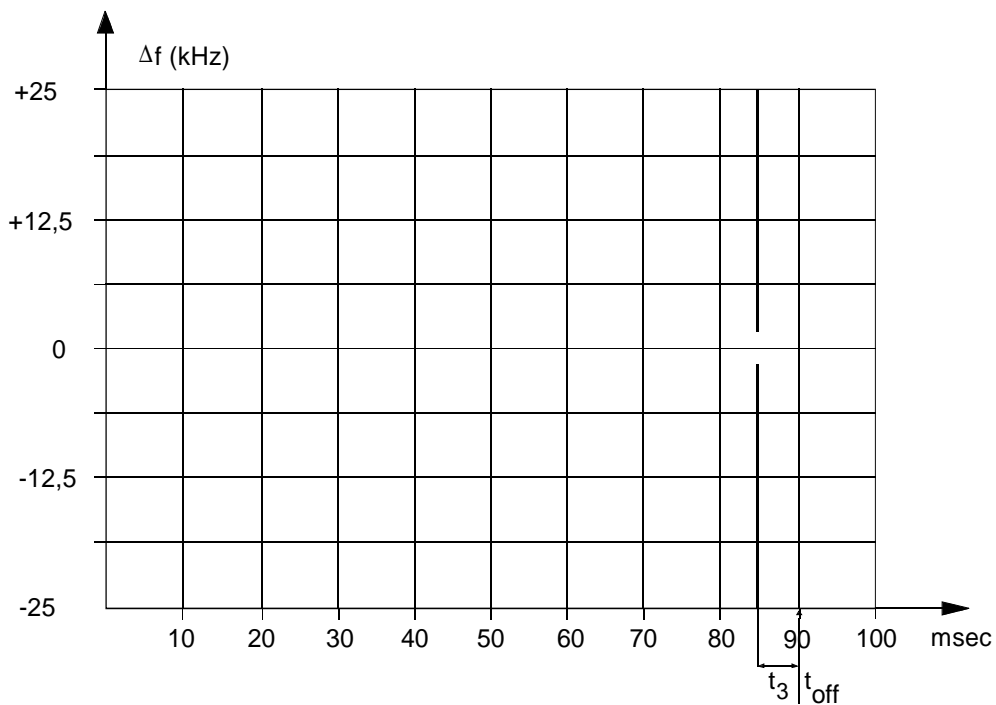

Figure 3: Limits

---

## 9 Receiver

### 9.1 Harmonic distortion and rated audio frequency output power

#### 9.1.1 Definition

The harmonic distortion at the receiver output is defined as the ratio, expressed as a percentage, of the total rms voltage of all the harmonic components of the modulation audio frequency to the total rms voltage of the signal delivered by the receiver.

The rated audio-frequency output power is the value stated by the manufacturer to be the maximum power available at the output, for which all the requirements of the present document are met.

#### 9.1.2 Methods of measurement

A test signal at the level of +100 dB $\mu$ V, at a carrier frequency equal to the nominal frequency of the receiver and modulated by the normal test modulation (see subclause 6.4) shall be applied to the receiver input under the conditions specified in subclause 6.2.

For each measurement, the receiver's audio frequency volume control shall be set so as to obtain, in a resistive load which simulates the receiver's operating load, the rated audio frequency output power. The value of this load shall be stated by the manufacturer.

Under normal test conditions (see subclause 5.3) the test signal shall be modulated successively at 300 Hz and 1 kHz with a constant modulation index of 3 (ratio between the frequency deviation and the modulation frequency). The harmonic distortion and audio frequency output power shall be measured at the frequencies specified above.

Under extreme test conditions (subclauses 5.4.1 and 5.4.2 applied simultaneously), the tests shall be made at the receiver's nominal frequency and at the nominal frequency  $\pm 1,5$  kHz. For these tests, the modulation shall be 1 kHz and the frequency deviation shall be  $\pm 3$  kHz.

#### 9.1.3 Limits

The rated audio frequency output power shall be at least:

- 2 W in a loudspeaker;
- 1 mW in the headset earphone if provided.

The harmonic distortion shall not exceed 10 %.

### 9.2 Audio frequency response

#### 9.2.1 Definition

The audio frequency response is the variation in the receiver's audio frequency output level as a function of the modulating frequency of the radio frequency signal with constant deviation applied to its input.



## 9.2.2 Method of measurement

A test signal of +60 dB $\mu$ V (e.m.f.), at a carrier frequency equal to the nominal frequency of the receiver and modulated with normal test modulation (see subclause 6.4), shall be applied to the receiver antenna port under the conditions specified in subclause 6.1.

The receiver's audio frequency power control shall be set so as to produce a power level equal to 50 % of the rated output power (see subclause 9.1). This setting shall remain unchanged during the test.

The frequency deviation shall then be reduced to 1 kHz and the audio output is the reference point in figure 4 (1 kHz corresponds to 0 dB).

The frequency deviation shall remain constant while the modulation frequency is varied between 300 Hz and 3 kHz and the output level shall then be measured.

The measurement shall be repeated with a test signal at frequencies 1,5 kHz above and below the nominal frequency of the receiver.

## 9.2.3 Limits

The audio frequency response shall not deviate by more than +1 dB; or

3 dB from a characteristic giving the output level as a function of the audio frequency, decreasing by 6 dB per octave and passing through the measured point at 1 kHz (figure 4).

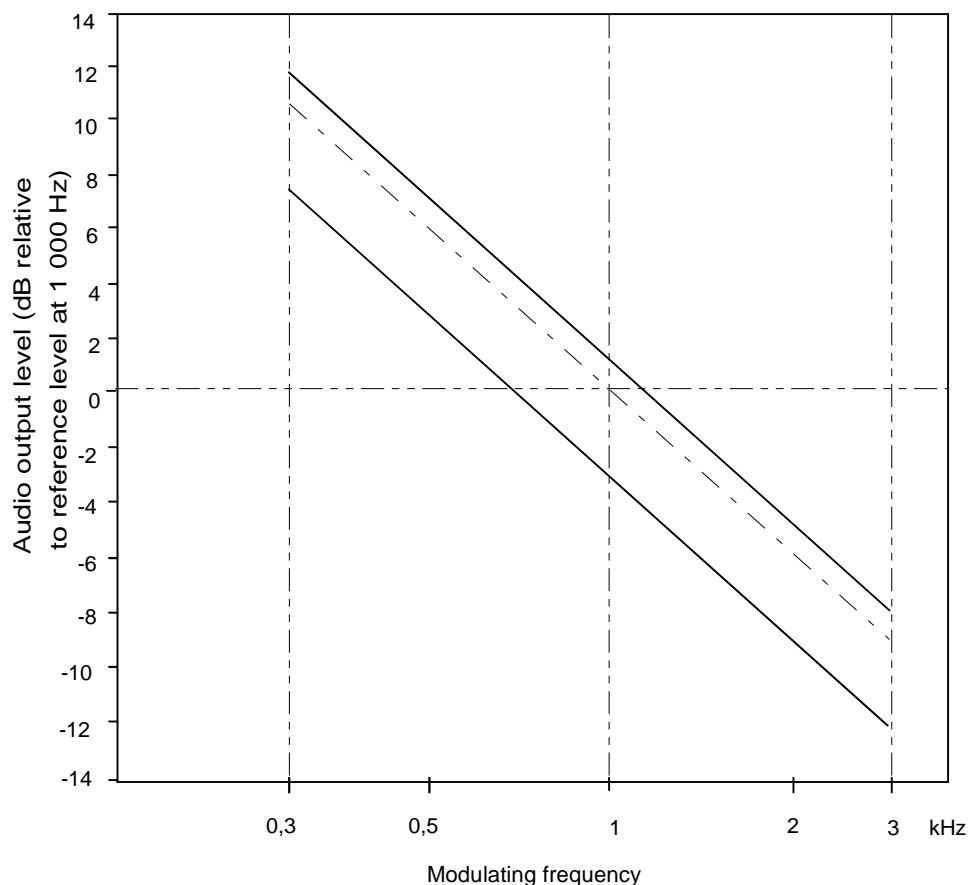

**Figure 4: Audio frequency response**

## 9.3 Maximum usable sensitivity

### 9.3.1 Definition

The maximum usable sensitivity of the receiver is the minimum level of the signal (emf) at the nominal frequency of the receiver which, when applied to the receiver input with normal test modulation (see subclause 6.4), will produce:

- in all cases, an audio frequency output power equal to 50 % of the rated audio frequency output power (see subclause 9.1); and
- a SINAD ratio of 20 dB, measured at the receiver audio frequency power output through a psophometric telephone filtering network such as described in ITU-T Recommendation P.53 [5].

### 9.3.2 Method of measurement

A test signal at a carrier frequency equal to the nominal frequency of the receiver, modulated by the normal test modulation (see subclause 6.4) shall be applied to the receiver input. An audio frequency load and a measuring instrument for measuring the SINAD ratio (through a psophometric network and as specified in subclause 9.3.1) shall be connected to the receiver audio frequency output.

The level of the test signal shall be adjusted until a SINAD ratio of 20 dB is obtained, using the psophometric network and with the receiver's audio frequency power control adjusted to produce 50 % of the rated audio frequency output power. Under these conditions, the level of the test signal at the input is the value of the reference maximum usable sensitivity which shall be recorded.

The measurements shall be made under normal test conditions (see subclause 5.3) and under extreme test conditions (subclauses 5.4.1 and 5.4.2 applied simultaneously).

A receiver audio frequency output power variation of  $\pm 3$  dB relative to 50 % of the rated audio frequency output power may be allowed for sensitivity measurements under extreme test conditions.

### 9.3.3 Limits

The maximum usable sensitivity shall be less than +6 dB $\mu$ V (emf) under normal test conditions and less than +12 dB $\mu$ V (emf) under extreme conditions.

## 9.4 Co-channel rejection

### 9.4.1 Definition

The co-channel rejection is a measure of the capability of the receiver to receive a wanted modulated signal without exceeding a given degradation due to the presence of an unwanted modulated signal, both signals being at the nominal frequency of the receiver.

### 9.4.2 Method of measurement

The two input signals shall be connected to the receiver via a combining network (see subclause 6.2). The wanted signal shall have normal test modulation (see subclause 6.4). The unwanted signal shall be modulated by 400 Hz with a deviation of  $\pm 3$  kHz. Both input signals shall be at the nominal frequency of the receiver under test and the measurement repeated for displacements of the unwanted signal of  $\pm 3$  kHz.

The wanted input signal shall be set to the value corresponding to the measured maximum usable sensitivity (subclause 9.3). The amplitude of the unwanted input signal shall then be adjusted until the SINAD ratio (psophometrically weighted) at the output of the receiver is reduced to 14 dB.

The co-channel rejection ratio shall be expressed as the ratio in dB of the level of the unwanted signal to the level of the wanted signal at the receiver input for which the specified reduction in SINAD ratio occurs.

### 9.4.3 Limit

The co-channel rejection ratio shall be between -10 dB and 0 dB.

## 9.5 Adjacent channel selectivity

### 9.5.1 Definition

The adjacent channel selectivity is a measure of the capability of the receiver to receive a wanted modulated signal without exceeding a given degradation due to the presence of an unwanted modulated signal which differs in frequency from the wanted signal by 25 kHz.

### 9.5.2 Method of measurement

The two input signals shall be applied to the receiver input via a combining network (see subclause 6.2). The wanted signal shall be at the nominal frequency of the receiver and shall have normal test modulation (see subclause 6.4). The unwanted signal shall be modulated by 400 Hz with a deviation of  $\pm 3$  kHz, and shall be at the frequency of the channel immediately above that of the wanted signal.

The wanted input signal shall be set to the value corresponding to the measured maximum usable sensitivity (subclause 9.3). The amplitude of the unwanted input signal shall then be adjusted until the SINAD ratio (psophometrically weighted) at the receiver output is reduced to 14 dB. The measurement shall be repeated with an unwanted signal at the frequency of the channel below that of the wanted signal.

The adjacent channel selectivity shall be expressed as the lower value of the ratios in dB for the upper and lower adjacent channels of the level of the unwanted signal to the level of the wanted signal.

The measurements shall then be repeated under extreme test conditions (subclauses 5.4.1 and 5.4.2 applied simultaneously) with the wanted signal set to the value corresponding to the reference maximum usable sensitivity under these conditions.

### 9.5.3 Limits

The adjacent channel selectivity shall be not less than 70 dB under normal test conditions and not less than 60 dB under extreme test conditions.

## 9.6 Spurious response rejection

### 9.6.1 Definition

The spurious response rejection is a measure of the capability of the receiver to discriminate between the wanted modulated signal at the nominal frequency and an unwanted signal at any other frequency at which a response is obtained.

### 9.6.2 Method of measurement

Two input signals shall be applied to the receiver input via a combining network (see subclause 6.2). The wanted signal shall be at the nominal frequency of the receiver and shall have normal test modulation (see subclause 6.4).

The unwanted signal shall be modulated by 400 Hz with a deviation of  $\pm 3$  kHz.

The wanted input signal shall be set to the value corresponding to the measured maximum usable sensitivity (subclause 9.3). The amplitude of the unwanted input signal shall be adjusted to an emf of +86 dB $\mu$ V. The frequency shall then be swept over the frequency range from 100 kHz to 2 GHz in steps less than 12,5 kHz. At any frequency at which a response is obtained, the input level shall be adjusted until the SINAD ratio (psophometrically weighted) is reduced to 14 dB.

The spurious response rejection ratio shall be expressed as the ratio in dB between the unwanted signal and the wanted signal at the receiver input when the specified reduction in the SINAD ratio is obtained.

### 9.6.3 Limit

At any frequency separated from the nominal frequency of the receiver by more than 25 kHz, the spurious response rejection ratio shall be not less than 70 dB.

## 9.7 Intermodulation response

### 9.7.1 Definition

The intermodulation response is a measure of the capability of a receiver to receive a wanted modulated signal without exceeding a given degradation due to the presence of two or more unwanted signals with a specific frequency relationship to the wanted signal frequency.

### 9.7.2 Method of measurement

Three signal generators, A, B and C shall be connected to the receiver via a combining network (see subclause 6.2). The wanted signal, represented by signal generator A shall be at the nominal frequency of the receiver and shall have normal test modulation (see subclause 6.4). The unwanted signal from signal generator B shall be un-modulated and adjusted to the frequency 50 kHz above (or below) the nominal frequency of the receiver. The second unwanted signal from signal generator C shall be modulated by 400 Hz with a deviation of  $\pm 3$  kHz, and adjusted to a frequency 100 kHz above (or below) the nominal frequency of the receiver.

The wanted input signal shall be set to a value corresponding to the measured maximum usable sensitivity (subclause 9.3). The amplitude of the two unwanted signals shall be maintained equal and shall be adjusted until the SINAD ratio (psophometrically weighted) at the receiver audio frequency output is reduced to 14 dB. The frequency of signal generator B shall be adjusted slightly to produce the maximum degradation of the SINAD ratio. The level of the two unwanted test signals shall be readjusted to restore the SINAD ratio of 14 dB.

The intermodulation response ratio shall be expressed as the ratio in dB between the two unwanted signals and the wanted signal at the receiver input, when the specified reduction in the SINAD ratio is obtained.

### 9.7.3 Limit

The intermodulation response ratio shall be not less than 68 dB.

## 9.8 Blocking or desensitization

### 9.8.1 Definition

Blocking is a change (generally a reduction) in the wanted audio frequency output power of the receiver or a reduction of the SINAD ratio due to an unwanted signal on another frequency.

### 9.8.2 Method of measurement

Two input signals shall be applied to the receiver via a combining network (see subclause 6.2). The modulated wanted signal shall be at the nominal frequency of the receiver and shall have normal test modulation (see subclause 6.4). Initially the unwanted signal shall be switched off and the wanted signal set to the value corresponding to the measured maximum usable sensitivity (subclause 9.3).

The audio frequency output power of the wanted signal shall be adjusted, where possible, to 50 % of the rated audio frequency output power and in the case of stepped volume controls, to the first step that provides an audio frequency output power of at least 50 % of the rated audio frequency output power. The unwanted signal shall be un-modulated at frequencies of  $\pm 1$  MHz,  $\pm 2$  MHz,  $\pm 5$  MHz and  $\pm 10$  MHz relative to the nominal frequency of the receiver. The input level of the unwanted signal, at all frequencies in the specified ranges, shall be adjusted so that the unwanted signal causes:

- a reduction of 3 dB in the audio frequency output level of the wanted signal; or
- a reduction to 14 dB of the SINAD ratio (psophometrically weighted) at the receiver audio frequency output, whichever occurs first. This level shall be noted.

### 9.8.3 Limit

The blocking level for any frequency within the specified ranges, shall be not less than 90 dB $\mu$ V, except at frequencies on which spurious responses are found (see subclause 9.6).

## 9.9 Conducted spurious emissions

### 9.9.1 Definition

Conducted spurious emissions from the receiver are components at any frequency, present at the receiver input port.

### 9.9.2 Method of measurement

The level of spurious emissions shall be measured as the power level at the antenna.

Conducted spurious radiations shall be measured as the power level of any discrete signal at the input terminals of the receiver. The receiver input terminals are connected to a spectrum analyser or selective voltmeter having an input impedance of 50  $\Omega$  and the receiver is switched on.

If the detecting device is not calibrated in terms of power input, the level of any detected components shall be determined by a substitution method using a signal generator.

The measurements shall extend over the frequency range of 9 kHz to 2 GHz.

### 9.9.3 Limit

The power of any spurious radiation shall not exceed 2 nW at any frequency in the range between 9 kHz and 2 GHz.

## 9.10 Radiated spurious emissions

### 9.10.1 Definition

Radiated spurious emissions from the receiver are components at any frequency radiated by the equipment cabinet and the structure.

### 9.10.2 Method of measurements

On a test site, selected from annex B, the equipment shall be placed at the specified height on a non-conducting support and in position closest to normal use as declared by the manufacturer.

The test antenna shall be orientated for vertical polarization and the length of the test antenna shall be chosen to correspond to the instantaneous frequency of the measuring receiver.

The output of the test antenna shall be connected to a measuring receiver.

The receiver shall be switched on without modulation, and measuring receiver shall be tuned over the frequency range 30 MHz to 2 GHz.

At each frequency at which a spurious component is detected:

- a) the test antenna shall be raised and lowered through the specified range of heights until a maximum signal level is detected on the measuring receiver;
- b) the receiver shall be rotated through 360° in the horizontal plane, until the maximum signal level is detected by the measuring receiver;
- c) the maximum signal level detected by the measuring receiver shall be noted;
- d) the receiver shall be replaced by a substitution antenna as defined in annex B;
- e) the substitution antenna shall be orientated for vertical polarization and the length of the substitution antenna shall be adjusted to correspond to the frequency of the spurious component detected;
- f) the substitution antenna shall be connected to a calibrated signal generator;
- g) the frequency of the calibrated signal generator shall be set to the frequency of the spurious component detected;
- h) the input attenuator setting of the measuring receiver shall be adjusted in order to increase the sensitivity of the measuring receiver, if necessary;
- i) the test antenna shall be raised and lowered through the specified range of heights to ensure that the maximum signal is received;
- j) the input signal to the substitution antenna shall be adjusted to the level that produces a level detected by the measuring receiver that is equal to the level noted while the spurious component was measured, corrected for the change of input attenuator setting of the measuring receiver;
- k) the input level to the substitution antenna shall be recorded as power level, corrected for the change of input attenuator setting of the measuring receiver;
- l) the measurement shall be repeated with the test antenna and the substitution antenna orientated for horizontal polarization;
- m) the measure of the effective radiated power of the spurious components is larger of the two power levels recorded for spurious component at the input to the substitution antenna, corrected for the gain of the antenna if necessary.

### 9.10.3 Limit

The power of any spurious radiation shall not exceed 2 nW at any frequency in the range between 30 MHz and 2 GHz.

## 9.11 Amplitude response of the receiver limiter

### 9.11.1 Definition

The amplitude response of the receiver limiter is the relationship between the radio frequency input level of a specific modulated signal and the audio frequency level at the receiver output.

### 9.11.2 Method of measurement

A test signal at the nominal frequency of the receiver and modulated by the normal test modulation (subclause 6.4) at a level of +6 dB $\mu$ V shall be applied to the receiver input and the audio frequency output level shall be adjusted to a level of 6 dB lower than the rated audio frequency output power (see subclause 9.1). The level of the input signal shall be increased to +100 dB $\mu$ V and the audio frequency output level shall be measured again.

### 9.11.3 Limit

The variation between the maximum and minimum value of the audio frequency output level shall not exceed 3 dB.

## 9.12 Receiver noise

### 9.12.1 Definition

The receiver noise is defined as the ratio, in dB, of the audio frequency power of the noise resulting from spurious effects to the audio frequency power produced by a radio frequency signal of average level, modulated by the normal test modulation and applied to the receiver input.

### 9.12.2 Method of measurement

A test signal with a level of +30 dB $\mu$ V emf at a carrier frequency equal to the nominal frequency of the receiver, and modulated by the normal test modulation specified in subclause 6.4, shall be applied to the receiver input. An audio frequency load shall be connected to the output terminals of the receiver. The audio frequency power control shall be set so as to produce the rated audio frequency output power level conforming to subclause 9.1.

The output signal shall be measured by an rms voltmeter with a -6 dB bandwidth of at least 20 kHz.

The modulation shall then be switched off and the audio frequency output level measured again.

### 9.12.3 Limit

The receiver noise shall not exceed -40 dB relative to the modulated signal.

## 9.13 Squelch operation

### 9.13.1 Definition

The purpose of the squelch facility is to mute the receiver audio output signal when the level of the signal at the receiver input is less than a given value.

### 9.13.2 Method of measurement

The following procedure shall be followed:

- a) with the squelch facility switched off, a test signal of +30 dB $\mu$ V, at a carrier frequency equal to the nominal frequency of the receiver and modulated by the normal test modulation specified in subclause 6.3, shall be applied to the input terminals of the receiver. An audio frequency load and a psophometric filtering network (see subclause 9.3.1) shall be connected to the output terminals of the receiver. The receiver's audio frequency power control shall be set so as to produce the rated output power defined in subclause 9.1:
  - the output signal shall be measured with the aid of an rms voltmeter;
  - the input signal shall then be suppressed, the squelch facility switched on and the audio frequency output level measured again;
- b) with the squelch facility switched off again, a test signal modulated by the normal test modulation shall be applied to the receiver input at a level of +6 dB $\mu$ V (emf) and the receiver shall be set to produce 50 % of the rated output power. The level of the input signal shall then be reduced and the squelch facility shall be switched on. The input signal shall then be increased until the above-mentioned output power is reached. The SINAD ratio and the input level shall then be measured;

- c) (applicable only to equipment with continuously adjustable squelch control) with the squelch facility switched off, a test signal with normal test modulation shall be applied to the receiver input at a level of +6 dB $\mu$ V (emf), and the receiver shall be adjusted to give 50 % of the rated audio output power. The level of the input signal shall then be reduced and the squelch facility shall be switched on. The squelch shall then be at its maximum position and the level of the input signal increased until the output power again is 50 % of the rated audio output power.

### 9.13.3 Limits

Under the conditions specified in a) subclause 9.13.2, the audio frequency output power shall not exceed -40 dB relative to the rated output power.

Under the conditions specified in b) subclause 9.13.2, the input level shall not exceed +6 dB $\mu$ V (emf) and the SINAD ratio shall be at least 20 dB.

Under the conditions specified in c) subclause 9.13.2, the input signal shall not exceed +6 dB $\mu$ V (emf) when the control is set at maximum.

## 9.14 Squelch hysteresis

### 9.14.1 Definition

Squelch hysteresis is the difference in dB between the receiver input signal levels at which the squelch opens and closes.

### 9.14.2 Method of measurement

If there is any squelch control on the exterior of the equipment it shall be placed in its maximum muted position. With the squelch facility switched on, an unmodulated input signal at a carrier frequency equal to the nominal frequency of the receiver shall be applied to the input of the receiver at a level sufficiently low to avoid opening the squelch. The input signal shall be increased to the level just opening the squelch. This input level shall be recorded. With the squelch still open, the level of the input signal shall be slowly decreased until the squelch mutes the receiver audio output again.

### 9.14.3 Limit

The squelch hysteresis shall be between 3 dB and 6 dB.

---

## 10 Secondary battery charger

### 10.1 General

If the equipment is powered by a secondary battery, the associated battery charger shall be submitted for conformance testing with the equipment.

The charger shall:

- have an indication to show that it is charging;
- have means to indicate when each battery has reached the fully charged condition;
- be able to fully charge discharged batteries in no more than 14 hours;
- automatically maintain fully charged batteries in a fully charged condition as long as the batteries remain in the charger.



## 10.2 Environmental tests

### 10.2.1 Introduction

The tests in this subclause are performed in order to simulate the environment in which the equipment is intended to operate.

The following tests shall be conducted in the order in which they appear. After being subjected to the various environmental conditions, the charger shall meet the requirements specified in subclause 10.3.

### 10.2.2 Vibration test

#### 10.2.2.1 Definition

This test determines the ability of equipment to withstand vibration without resulting in mechanical weakness or degradation in performance.

#### 10.2.2.2 Method of measurement

The EUT, complete with any shock and vibration absorbers with which it is provided, shall be clamped to the vibration table by its normal means of support and in its normal attitude. The EUT may be resiliently suspended to compensate for weight not capable of being withstood by the vibration table. Provision may be made to reduce or nullify any adverse effect on EUT performance which could be caused by the presence of an electro-magnetic field due to the vibration unit.

The EUT shall be subjected to sinusoidal vertical vibration at all frequencies between:

- 5 Hz and up to 13,2 Hz with an excursion of  $\pm 1 \text{ mm} \pm 10 \%$  (7 m/s<sup>2</sup> maximum acceleration at 13,2 Hz);
- above 13,2 Hz and up to 100 Hz with a constant maximum acceleration of 7 m/s<sup>2</sup>.

The frequency sweep rate shall be slow enough to allow the detection of resonances in any part of the EUT.

A resonance search shall be carried out throughout the test. If any resonance of the EUT has  $Q \geq 5$  measured relative to the base of the vibration table, the EUT shall be subjected to a further vibration endurance test at each resonant frequency at the vibration level specified in the test with a duration of two hours. If any resonance with  $Q < 5$  occurs the further endurance test shall be carried out at one single observed frequency. If no resonance occurred, the further endurance test shall be carried out at a frequency of 30 Hz.

The procedure shall be repeated with vibration in each of two mutually perpendicular directions in the horizontal plane.

After conducting the vibration tests, the equipment shall be inspected for any mechanical deterioration.

#### 10.2.2.3 Requirement

During vibration, any battery or equipment which it is designed to hold shall remain in position, and continue to be charged. There shall be no harmful deterioration of the charger, or battery or equipment which it is designed to hold, visible to the naked eye.

### 10.2.3 Shock tests

#### 10.2.3.1 Definition

This test determines the ability of equipment to withstand mechanical shock.

### 10.2.3.2 Method of measurement

The EUT, complete with any shock and vibration absorbers with which it is provided, shall be clamped to the table of the shock testing machine by its normal means of support and in its normal attitude.

The shock applied to the equipment shall consist of a pulse being one half-cycle of a sine wave in accordance with IEC 68-2-27 [7].

The peak acceleration shall be 30 g and the duration shall be 18 ms.

Three successive shocks shall be applied in each direction of the three mutually perpendicular axes of the EUT.

After the test, the equipment shall be inspected for any mechanical deterioration.

### 10.2.3.3 Requirement

During the shock tests, any battery or equipment which it is designed to hold shall remain in position, and continue to be charged. There shall be no harmful deterioration of the charger, or battery or equipment which it is designed to hold, visible to the naked eye.

## 10.2.4 Temperature tests

### 10.2.4.1 General

The tests to be carried out on the charger are described in the following paragraphs. The maximum rate of raising or reducing the temperature of the chamber in which the equipment is being tested shall be 1°C/minute.

### 10.2.4.2 Dry heat cycle

The charger shall be placed in a chamber of normal room temperature. Then the temperature shall be raised to and maintained at +55°C ( $\pm 3^\circ\text{C}$ ) for a period of at least 10 hours.

After this period any climatic control device provided in the charger may be switched on.

30 minutes later, the charger shall be switched on, and shall then be kept working continuously for a period of 2 hours.

The temperature of the chamber shall be maintained at +55°C ( $\pm 3^\circ\text{C}$ ) during the 2 hours 30 minutes period.

At the end of the test, and with the charger still in the chamber, the chamber shall be brought to room temperature in not less than 1 hour.

The charger shall then be exposed to normal room temperature and humidity for not less than 3 hours before the next test is carried out.

### 10.2.4.3 Damp heat cycle

The charger shall be placed in a chamber at normal room temperature and humidity which, steadily, over a period 3 hours ( $\pm 0,5$  hours), shall be heated from room temperature to +40°C ( $\pm 3^\circ\text{C}$ ) and shall during this period be brought to a relative humidity of 93 % ( $\pm 2$  %) so that excessive condensation is avoided.

These conditions shall be maintained for a period of at least 10 hours.

After this period, any climatic control devices provided within the charger may be switched on.

30 minutes later the charger shall be switched on, and shall then be kept working continuously for a period of 2 hours.

The temperature and relative humidity of the chamber shall be maintained at +40°C ( $\pm 3^\circ\text{C}$ ) and 93 % ( $\pm 2$  %) during the 2 hours 30 minutes period.

At the end of the test, and with the charger still in the chamber, the chamber shall be brought to room temperature in not less than 1 hour. The charger shall then be exposed to normal room temperature and humidity for not less than 3 hours, or until moisture has dispersed, whichever is longer, before the next test is carried out.

#### 10.2.4.4 Low temperature cycle

The charger shall be placed in a chamber at normal room temperature. Then the temperature shall be reduced to, and maintained at,  $-15^{\circ}\text{C}$  ( $\pm 3^{\circ}\text{C}$ ) for a period of at least 10 hours.

After this period, any climatic control devices and/or heat sources provided in the charger may be switched on.

At the end of the test, and with the charger still in the chamber, the chamber shall be brought to room temperature in not less than 1 hour. The equipment shall then be exposed to normal room temperature for not less than 3 hours, or until moisture has dispersed, whichever is longer, before the next test is carried out.

#### 10.2.5 Corrosion test

##### 10.2.5.1 General

This test may be omitted if sufficient evidence is provided by the manufacturer that the corresponding requirements of this subclause are met.

##### 10.2.5.2 Method of measurement

The charger shall be placed in a chamber fitted with apparatus capable of spraying in the form of fine mist, such as would be produced by a spray gun, salt solution to the following formula:

- sodium chloride: 26,5 grammes  $\pm 10$  %;
- magnesium chloride: 2,5 grammes  $\pm 10$  %;
- magnesium sulphate: 3,3 grammes  $\pm 10$  %;
- calcium chloride: 1,1 grammes  $\pm 10$  %;
- potassium chloride: 0,73 grammes  $\pm 10$  %;
- sodium bicarbonate: 0,20 grammes  $\pm 10$  %;
- sodium bromide: 0,28 grammes  $\pm 10$  %;

plus distilled water to make the solution up to 1 litre.

Alternatively a 5 % sodium chloride (NaCl) solution may be used.

The salt used for the test shall be high quality sodium chloride (NaCl) containing, when dry, not more than 0,1 % sodium iodide and not more than 0,3 % of total impurities.

Salt solution concentration shall be 5 ( $\pm 1$ ) % by weight.

The solution shall be prepared by dissolving 5 parts  $\pm 1$  by weight of salt in 95 parts by weight of distilled or de-mineralized water.

The pH value of the solution shall be between 6,5 and 7,2 at temperature of  $20^{\circ}\text{C}$  ( $\pm 2^{\circ}\text{C}$ ). The pH value shall be maintained within this range during conditioning; for this purpose, diluted hydrochloric acid or sodium hydroxide may be used to adjust the pH value, provided that the concentration of NaCl remains within the prescribed limits. The pH value shall be measured when preparing each new batch of solution.

The spraying apparatus shall be such that the products of corrosion cannot mix with the salt solution contained within the spray reservoir.

The charger shall be sprayed simultaneously on all its external surfaces with the salt solution for a period of 1 hour.

This spraying shall be carried out 4 times with a storage period of 7 days at  $+40^{\circ}\text{C}$  ( $\pm 2^{\circ}\text{C}$ ) after each spraying. The relative humidity during storage shall be maintained between 90 % and 95 %.

At the end of the total period the charger shall be examined visually.

### 10.2.5.3 Requirements

There shall be no undue deterioration or corrosion of the metal parts, finishes, material, or component parts visible to the naked eye.

## 10.3 Charging time

Place a fully discharged battery in the charger and record the time taken until the fully charged indication is achieved. This time shall not exceed 14 hours. Remove the battery from the charger and perform the test detailed in subclause 4.7.

## Annex A (normative): Measuring receiver for adjacent channel power measurement

### A.1 Power measuring receiver specification

The power measuring receiver consists of a mixer, an Intermediate Frequency (IF) filter, an oscillator, an amplifier, a variable attenuator and an rms value indicator. Instead of the variable attenuator with the rms value indicator it is also possible to use an rms voltmeter calibrated in dB. The technical characteristics of the power measuring receiver are given in subclause A.1.1 following.

#### A.1.1 IF filter

The IF filter shall be within the limits of the following selectivity characteristics given in figure A.1 below.

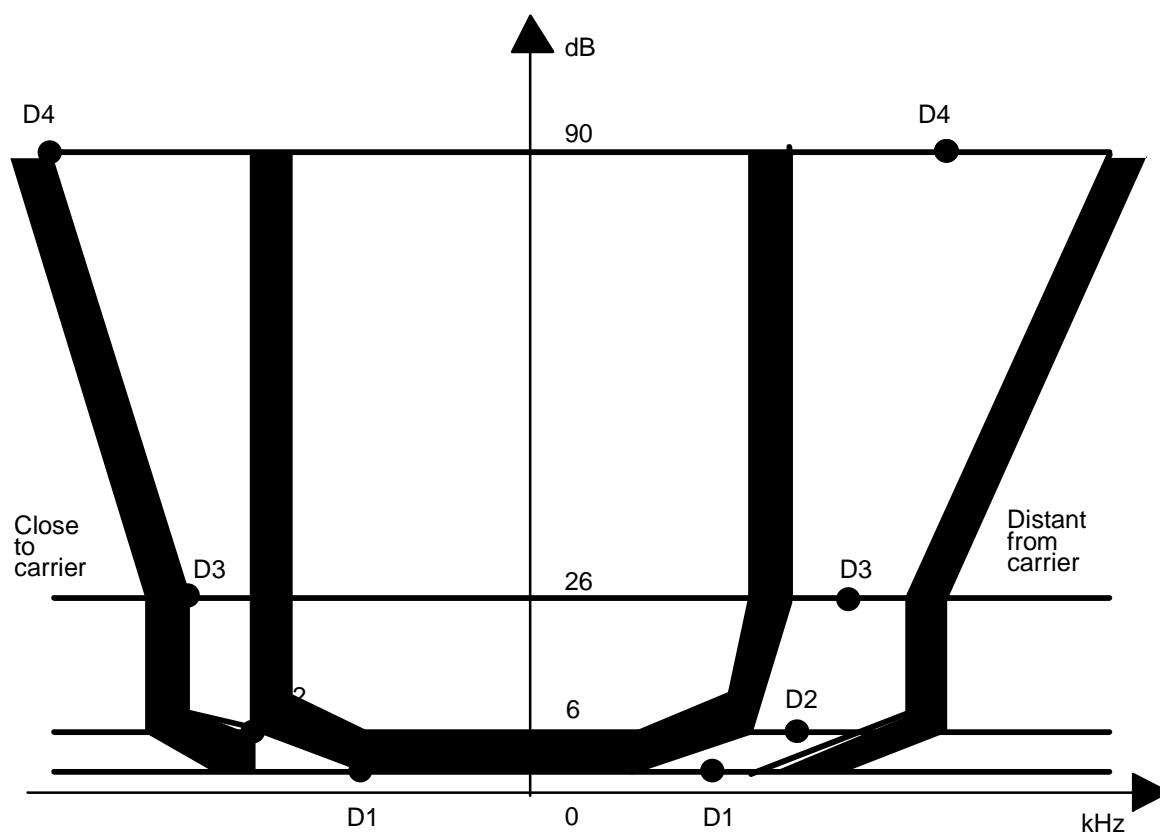

Figure A.1

The selectivity characteristics shall keep the following frequency separations from the nominal centre frequency of the adjacent channel given in table A.1.

Table A.1: Selectivity characteristic

Frequency separation of filter curve from nominal centre frequency of adjacent channel (kHz)			
D1	D2	D3	D4
5	8,0	9,25	13,25

The attenuation points shall not exceed the following tolerances given in tables A.2 and A.3 below.

**Table A.2: Attenuation points close to carrier**

Tolerance range (kHz)			
D1	D2	D3	D4
+3,1	±0,1	-1,35	-5,35

**Table A.3: Attenuation points distant from the carrier**

Tolerance range (kHz)			
D1	D2	D3	D4
±3,5	±3,5	±3,5	+3,5 -7,5

The minimum attenuation of the filter outside the 90 dB attenuation points shall be equal to or greater than 90 dB.

## A.1.2 Attenuation indicator

The attenuation indicator shall have a minimum range of 80 dB and a reading accuracy of 1 dB. With a view to future regulations an attenuation of 90 dB or more is recommended.

## A.1.3 rms value indicator

The instrument shall accurately indicate non-sinusoidal signals in a ratio of up to 10:1 between peak value and rms value.

## A.1.4 Oscillator and amplifier

The oscillator and the amplifier shall be designed in such a way that the measurement of the adjacent channel power of a low-noise un-modulated transmitter, whose self-noise has a negligible influence on the measurement result, yields a measured value of  $\leq -90$  dB.

## Annex B (normative): Radiated measurements

### B.1 Test sites and general arrangements for measurements involving the use of radiated fields

#### B.1.1 Outdoor test site

The outdoor test site shall be on a reasonably level surface or ground. At one point on the site, a ground plane of at least 5 m diameter shall be provided. In the middle of this ground plane, a non-conducting support, capable of rotation through 360° in the horizontal plane, shall be used to support the test sample at 1,5 m above the ground plane. The test site shall be large enough to allow the erection of a measuring or transmitting antenna at a distance of  $\lambda/2$  or 3 m whichever is the greater. The distance actually used shall be recorded with the results of the tests carried out on the site.

Sufficient precautions shall be taken to ensure that reflections from extraneous objects adjacent to the site and ground reflections do not degrade the measurements results.

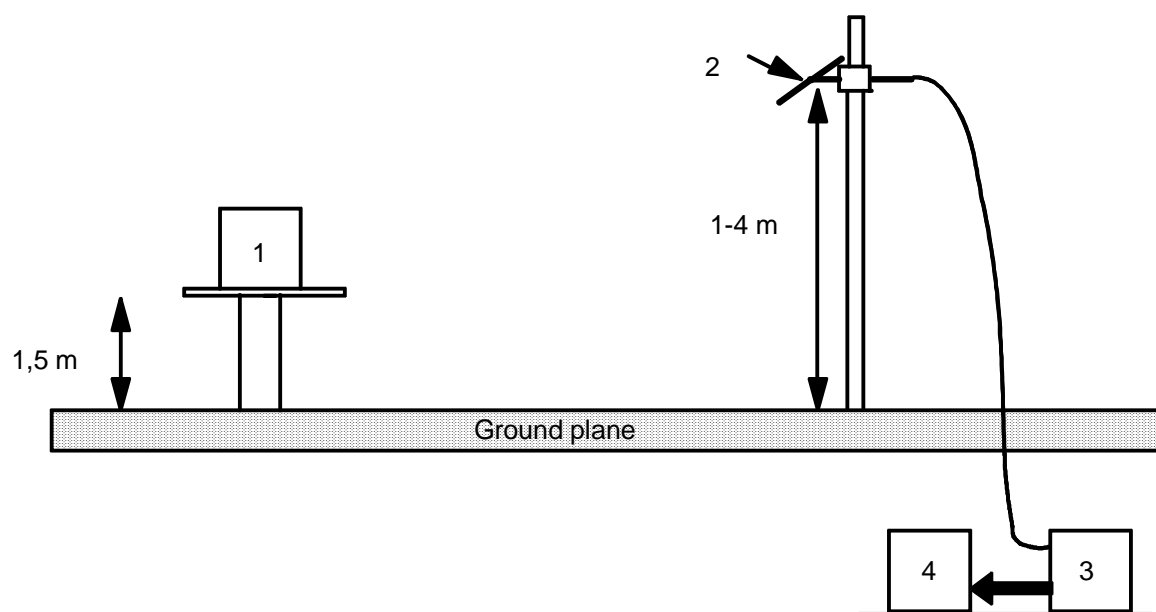

Key:

- 1 Equipment under test
- 2 Test antenna
- 3 High pass filter (necessary for strong fundamental Tx radiation)
- 4 Spectrum analyser or measuring receiver

Figure B.1

## B.1.2 Test antenna

The test antenna is used to detect the radiation from both the test sample and the substitution antenna, when the site is used for radiation measurements; where necessary, it is used as a transmitting antenna, when the site is used for the measurement of receiver characteristics.

This antenna is mounted on a support such as to allow the antenna to be used in either horizontal or vertical polarization and for the height of its centre above ground to be varied over the range 1 m to 4 m. Preferably a test antenna with pronounced directivity should be used. The size of the test antenna along the measurement axis shall not exceed 20 % of the measuring distance.

For receiver and transmitter radiation measurements, the test antenna is connected to a measuring receiver, capable of being tuned to any frequency under investigation and of measuring accurately the relative levels of signals at its input. For receiver radiated sensitivity measurements the test antenna is connected to a signal generator.

## B.1.3 Substitution antenna

When measuring in the frequency range up to 1 GHz the substitution antenna shall be a  $\lambda/2$  dipole, resonant at the frequency under consideration, or a shortened dipole, calibrated to the  $\lambda/2$  dipole. When measuring in the frequency range above 4 GHz a horn radiator shall be used. For measurements between 1 GHz and 4 GHz either a  $\lambda/2$  dipole or a horn radiator may be used. The centre of this antenna shall coincide with the reference point of the test sample it has replaced. This reference point shall be the volume centre of the sample when its antenna is mounted inside the cabinet, or the point where an external antenna is connected to the cabinet.

The distance between the lower extremity of the dipole and the ground shall be at least 0,3 m.

The substitution antenna shall be connected to a calibrated signal generator when the site is used for spurious radiation measurements and transmitter effective radiated power measurements. The substitution antenna shall be connected to a calibrated measuring receiver when the site is used for the measurement of receiver sensitivity.

The signal generator and the receiver shall be operating at the frequencies under investigation and shall be connected to the antenna through suitable matching and balancing networks.

NOTE: The gain of a horn antenna is generally expressed relative to an isotropic radiator.

## B.1.4 Optional additional indoor site

When the frequency of the signals being measured is greater than 80 MHz, use may be made of an indoor site. If this alternative site is used, this shall be recorded in the test report.

The measurement site may be a laboratory room with a minimum area of 6 m by 7 m and at least 2,7 m in height.

Apart from the measuring apparatus and the operator, the room shall be as free as possible from reflecting objects other than the walls, floor and ceiling.

The potential reflections from the wall behind the equipment under test are reduced by placing a barrier of absorbent material in front of it. The corner reflector around the test antenna is used to reduce the effect of reflections from the opposite wall and from the floor and ceiling in the case of horizontally polarized measurements. Similarly, the corner reflector reduces the effects of reflections from the side walls for vertically polarized measurements. For the lower part of the frequency range (below approximately 175 MHz) no corner reflector or absorbent barrier is needed. For practical reasons, the  $\lambda/2$  antenna in figure B.2 may be replaced by an antenna of constant length, provided that this length is between  $\lambda/4$  and  $\lambda$  at the frequency of measurement and the sensitivity of the measuring system is sufficient. In the same way the distance of  $\lambda/2$  to the apex may be varied.

The test antenna, measuring receiver, substitution antenna and calibrated signal generator are used in a way similar to that of the general method.

To ensure that errors are not caused by the propagation path approaching the point at which phase cancellation between direct and the remaining reflected signals occurs, the substitution antenna shall be moved through a distance of  $\pm 0,1$  m in the direction of the test antenna as well as in the two directions perpendicular to this first direction.



If these changes of distance cause a signal change of greater than 2 dB, the test sample should be re-sited until a change of less than 2 dB is obtained.

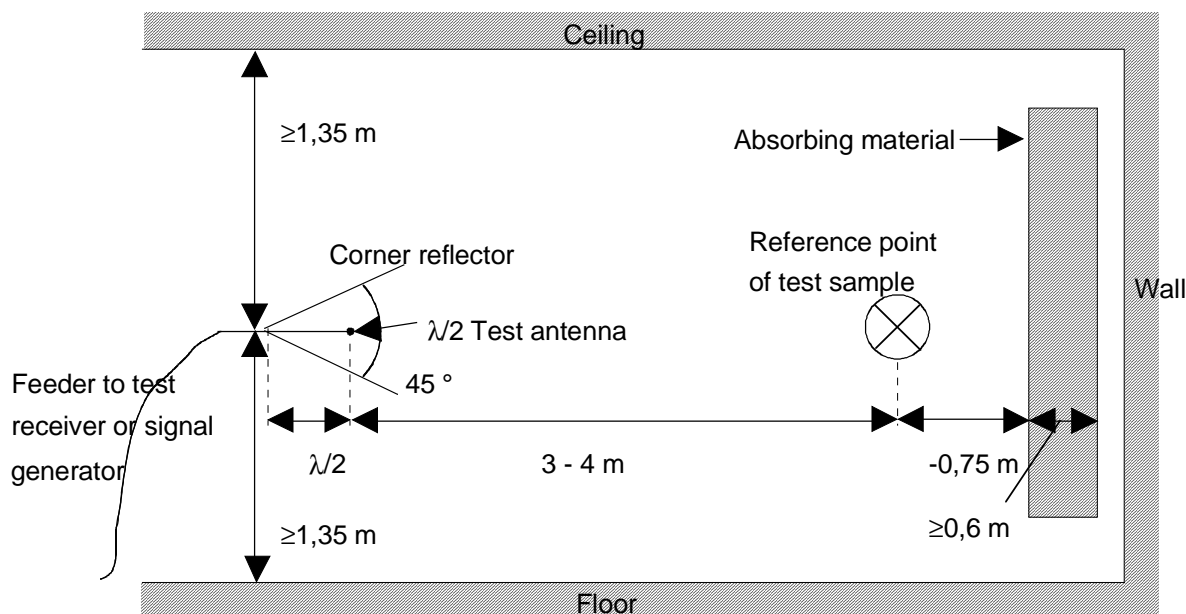

Figure B.2: Indoor site arrangement (shown for horizontal polarization)

## B.2 Guidance on the use of radiation test sites

For measurements involving the use of radiated fields, use may be made of a test site in conformity with the requirements of subclause B.1 of this annex. When using such a test site, the following conditions should be observed to ensure consistency of measuring results.

### B.2.1 Measuring distance

Evidence indicates that the measuring distance is not critical and does not significantly affect the measuring results, provided that the distance is not less than  $\lambda/2$  at the frequency of measurement, and the precautions described in this annex are observed. Measuring distances of 3 m, 5 m, 10 m and 30 m are in common use in European test laboratories.

### B.2.2 Test antenna

Different types of test antenna may be used, since performing substitution measurements reduces the effect of the errors on the measuring results.

Height variation of the test antenna over a range of 1 m to 4 m is essential in order to find the point at which the radiation is a maximum.

Height variation of the test antenna may not be necessary at the lower frequencies below about 100 MHz.

### B.2.3 Substitution antenna

Variations in the measuring results may occur with the use of different types of substitution antenna at the lower frequencies below about 80 MHz.

Where a shortened dipole antenna is used at these frequencies, details of the type of antenna used should be included with the results of the tests carried out on the site. Correction factors shall be taken into account when shortened dipole antennas are used.

## B.2.4 Artificial antenna

The dimensions of the artificial antenna used during radiated measurements should be small in relation to the sample under test.

Where possible, a direct connection should be used between the artificial antenna and the test sample.

In cases where it is necessary to use a connecting cable, precautions should be taken to reduce the radiation from this cable by, for example, the use of ferrite cores or double screened cables.

## B.2.5 Auxiliary cables

The position of auxiliary cables (power supply and microphone cables etc.) which are not adequately decoupled may cause variations in the measuring results. In order to get reproducible results, cables and wires of auxiliaries should be arranged vertically downwards (through a hole in the non conducting support).

## B.2.6 Acoustic measuring arrangement

When carrying out measurements of the maximum usable sensitivity (radiated) of the receiver, the audio output shall be monitored by acoustically coupling the audio signal from the receiver loudspeaker/transducer to the test microphone. On the radiation test site all conducting materials shall be placed below the ground surface and the acoustic signal is conveyed from the receiver to the test microphone in a non-conducting acoustic pipe.

The acoustic pipe shall have an appropriate length. The acoustic pipe shall have an inner diameter of 6 mm and a wall thickness of 1,5 mm. A plastic funnel of a diameter corresponding to the receiver loudspeaker/transducer shall be attached to the receiver surface centred in front of the receiver loudspeaker/transducer. The plastic funnel shall be very soft at the attachment point to the receiver in order to avoid mechanical resonance. The narrow end of the plastic funnel shall be connected to the one end of the acoustic pipe and the test microphone to the other.

---

## B.3 Further optional alternative indoor test site using an anechoic chamber

For radiation measurements when the frequency of the signals being measured is greater than 30 MHz, use may be made of an indoor site being a well-shielded anechoic chamber simulating free space environment. If such a chamber is used, this shall be recorded in the test report.

The test antenna, measuring receiver, substitution antenna and calibrated signal generator are used in a way similar to that of the general method, subclause B.1. In the range between 30 MHz and 100 MHz some additional calibration may be necessary.

An example of a typical measurement site may be an electrically shielded anechoic chamber being 10 m long, 5 m broad and 5 m high.

Walls and ceiling should be coated with RF absorbers of 1 m height.

The base should be covered with absorbing material 1 m thick, and a wooden floor, able to carry test equipment and operators.

A measuring distance of 3 m to 5 m in the long middle axis of the chamber can be used for measurements up to 12,75 GHz.

The construction of the anechoic chamber is described in the following subclauses.

### B.3.1 Example of the construction of a shielded anechoic chamber

Free-field measurements can be simulated in a shielded measuring chamber where the walls are coated with RF absorbers.

Figure B.3 shows the requirements for shielding loss and wall return loss of such a room.

As dimensions and characteristics of usual absorber materials are critical below 100 MHz (height of absorbers < 1 m, reflection attenuation < 20 dB) such a room is preferably suitable for measurements above 100 MHz.

Figure B.4 shows the construction of a shielded measuring chamber having a base area of 5 m by 10 m and a height of 5 m.

Ceilings and walls are coated with pyramidal formed absorbers approximately 1 m high. The base is covered with absorbers which are able to carry and which forms a sort of floor.

The available internal dimensions of the room are 3 m x 8 m x 3 m, so that a measuring distance of maximum 5 m length in the middle axis of this room is available.

At 100 MHz the measuring distance can be extended up to a maximum of 2 lambda.

The floor absorbers reject floor reflections so that the antenna height need not be changed and floor reflection influences need not be considered.

All measuring results can therefore be checked with simple calculations and the measuring tolerances have the smallest possible values due to the simple measuring configuration.

For special measurements it can be necessary to re-introduce floor reflections. Taking away the floor absorbers would mean a removal of approximately 24 m<sup>3</sup> absorber material. Therefore the floor absorbers are covered with metal plates of metallic nets instead.

### B.3.2 Influence of parasitic reflections in anechoic chambers

For free-space propagation in the far field condition the correlation  $E = E_0(R_0/R)$  is valid for the dependence of the field strength  $E$  on the distance  $R$ , whereby  $E_0$  is the reference field strength in the reference distance  $R_0$ .

It is useful to use just this correlation for comparison measurements, as all constants are eliminated with the ratio and neither cable attenuation nor antenna mismatch or antenna dimensions are of importance.

Deviations from the ideal curve can be seen easily if the logarithm of the above equation is used, because the ideal correlation of field strength and distance can then be shown as a straight line and the deviations occurring in practice are clearly visible. This indirect method shows the disturbances due to reflections more readily and is far less problematical than the direct measurement of reflection attenuation.

With an anechoic chamber of the dimensions suggested in subclause B.3 at low frequencies up to 100 MHz there are no far field conditions, and therefore reflections are stronger so that careful calibration is necessary.

In the medium frequency range from 100 MHz to 1 GHz the dependence of the field strength on the distance meets the expectations very well.

In the frequency range of 1 GHz to 12,75 GHz, because more reflections will occur, the dependence of the field strength on the distance will not correlate so closely.

### B.3.3 Calibration of the shielded anechoic chamber

Careful calibration of the chamber shall be performed over the range 30 MHz to 12,75 GHz.

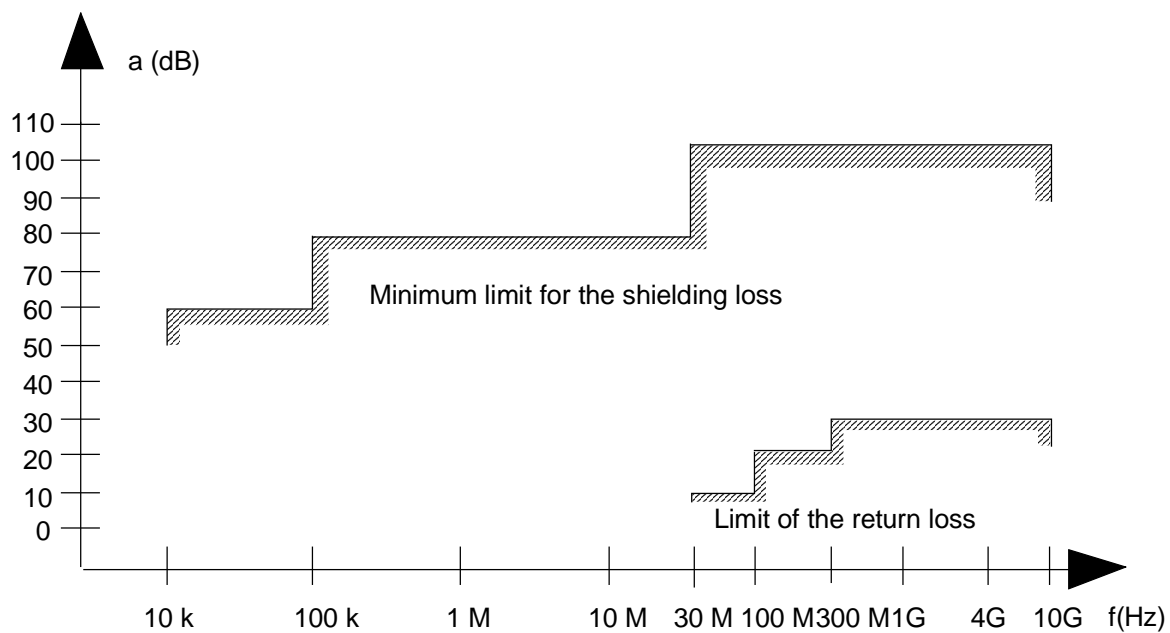
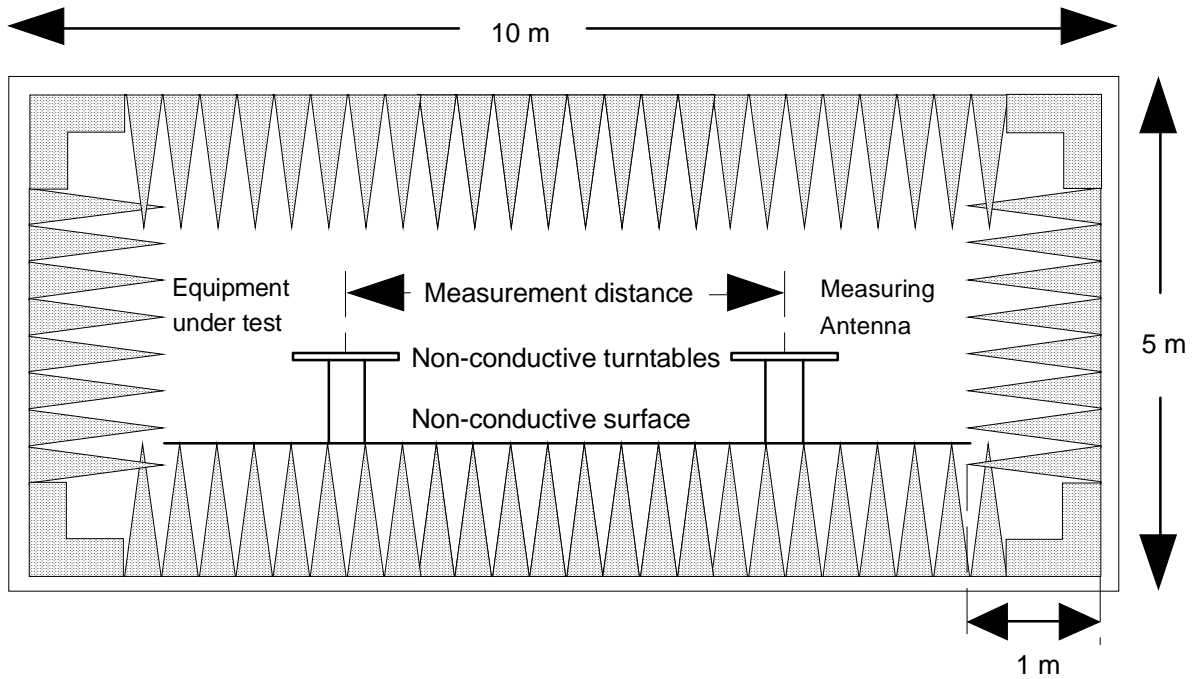

Figure B.3: Specifications for shielding and reflections



Ground plan

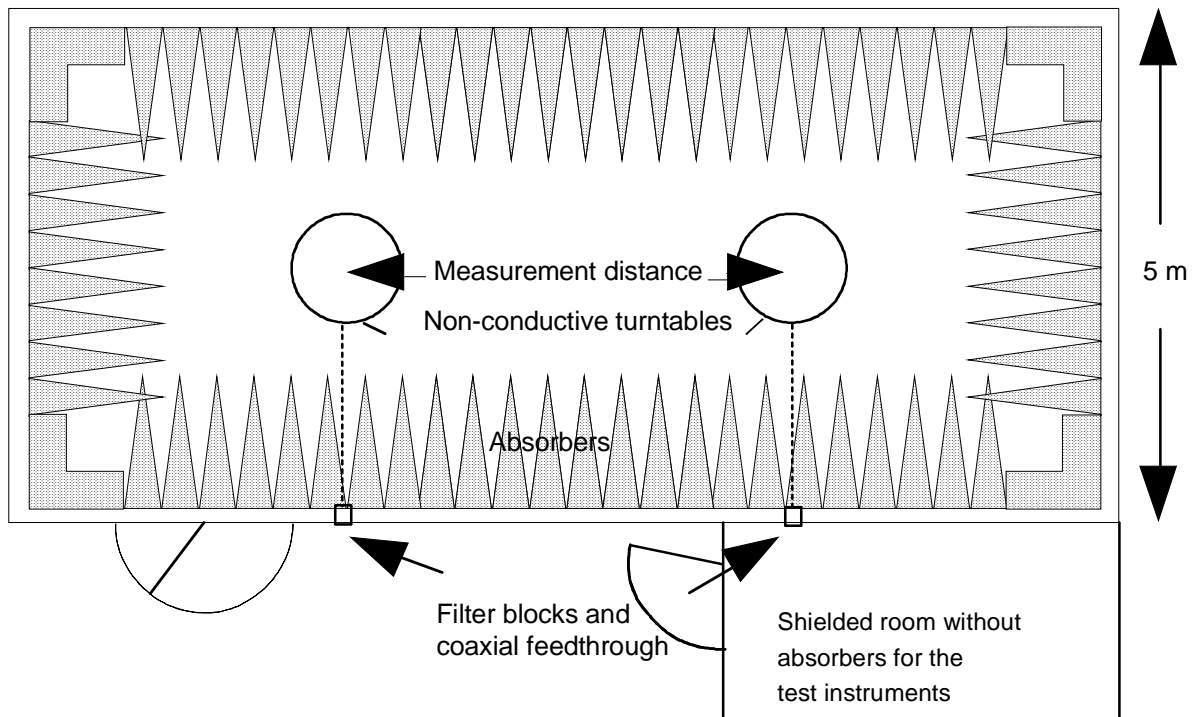

Figure B.4: Example of construction of an anechoic shielded chamber

---

## B.4 Standard position

The standard position in all test sites, except the stripline arrangement, for equipment which is not intended to be worn on a person, including hand-held equipment, shall be on a non conducting support, height 1,5 m, capable of rotating about a vertical axis through the equipment. The standard position of the equipment shall be the following:

- a) for equipment with an internal antenna, it shall be placed in the position closest to normal use as declared by the manufacturer;
- b) for equipment with a rigid external antenna, the antenna shall be vertical;
- c) for equipment with a non-rigid external antenna, the antenna shall be extended vertically upwards by a non-conducting support.

Equipment which is intended to be worn on a person shall be tested using a salty man as support as described in ETR 273 [8], part 7, Artificial human beings.

The simulated man comprises a rotatable acrylic tube filled with salt (NaCl) water with acrylic caps at both ends, placed on the ground.

The container shall have the following dimensions:

- height: 1,7 m;
- outside diameter: 305 mm;
- sidewall thickness: 4,8 mm.

The container shall be filled with a salt (NaCl) solution of 1,49 g per litre of distilled water. ( $\epsilon_r = 77$ ,  $\sigma = 26$  S/m).

The equipment shall be fixed to the surface of the simulated man, at the appropriate height for the equipment.

NOTE: To reduce the weight of the simulated man it may be possible to use an alternative tube which has a hollow centre of 220 mm maximum diameter.

---

## History

<b>Document history</b>			
V1.1.1	December 1999	Public Enquiry	PE 200016: 1999-12-22 to 2000-04-21