

Draft **ETSI EN 301 465** V1.1.1 (1999-10)

---

*European Standard (Telecommunications series)*

**Private Integrated Services Network (PISN);  
Circuit emulation specification;  
Emulation of Basic Access by ATM Networks**

---



---

**Reference**

DEN/ECMA-00154 (dkc00ico.PDF)

---

**Keywords**

Access, ATM, basic, PISN

**ETSI**

---

**Postal address**

F-06921 Sophia Antipolis Cedex - FRANCE

---

**Office address**

650 Route des Lucioles - Sophia Antipolis  
Valbonne - FRANCE  
Tel.: +33 4 92 94 42 00 Fax: +33 4 93 65 47 16  
Siret N° 348 623 562 00017 - NAF 742 C  
Association à but non lucratif enregistrée à la  
Sous-Préfecture de Grasse (06) N° 7803/88

---

**Internet**

secretariat@etsi.fr  
Individual copies of this ETSI deliverable  
can be downloaded from  
<http://www.etsi.org>  
If you find errors in the present document, send your  
comment to: editor@etsi.fr

---

**Important notice**

This ETSI deliverable may be made available in more than one electronic version or in print. In any case of existing or perceived difference in contents between such versions, the reference version is the Portable Document Format (PDF). In case of dispute, the reference should be the printing on ETSI printers of the PDF version kept on a specific network drive within ETSI Secretariat.

---

**Copyright Notification**

No part may be reproduced except as authorized by written permission.  
The copyright and the foregoing restriction extend to reproduction in all media.

© European Telecommunications Standards Institute 1999.  
All rights reserved.

---

# Contents

Intellectual Property Rights .....	5
Foreword .....	5
Brief History .....	5
1 Scope.....	7
2 Conformance.....	7
3 References.....	7
4 Definitions and abbreviations .....	8
4.1 External definitions.....	8
4.2 Special definitions.....	8
4.3 Abbreviations.....	8
5 Reference configuration .....	9
6 Mapping functions .....	10
6.1 The mapping scheme .....	10
6.2 Functions of the CV1 channel.....	10
6.3 Mapping of a 4-octet-block structure into ATM cells.....	10
7 ATM virtual channel requirements for basic access emulation .....	11
7.1 ATM Peak Cell Rate (PCR).....	11
7.2 Broadband Bearer Capability.....	11
7.3 ATM Adaptation Layer Parameters.....	11
7.4 ATM Signalling/Call Establishment Procedures.....	11
<b>Annex A (normative): Contents and functions of the CV1 channel</b> .....	<b>12</b>
A.1 Bit structure of the CV1 channel .....	12
A.2 Command/Indication Channel Operation (C/I Channel) .....	12
<b>Annex B (normative): Protocol Implementation Conformance Statement (PICS) Proforma</b> .....	<b>14</b>
B.1 Introduction.....	14
B.2 Instructions for completing the PICS proforma.....	14
B.2.1 General structure of the PICS proforma.....	14
B.2.2 Additional information.....	15
B.2.3 Exception information .....	15
B.3 PICS Proforma .....	15
B.3.1 Implementation identification .....	15
B.3.2 Protocol summary .....	16
B.3.3 General.....	16
B.3.4 Procedures .....	16
B.3.5 Coding .....	16

<b>Annex C (normative):</b>	<b>The Monitor Channel Procedure</b>	<b>17</b>
C.1	Idle .....	17
C.2	Start of Transmission.....	17
C.3	Reception of the First Data Unit.....	17
C.4	Subsequent Reception.....	17
C.5	End of Transmission (EOM) .....	17
C.6	Abort .....	17
	Bibliography.....	20
	History.....	21

---

## Intellectual Property Rights

IPRs essential or potentially essential to the present document may have been declared to ETSI. The information pertaining to these essential IPRs, if any, is publicly available for **ETSI members and non-members**, and can be found in SR 000 314: "*Intellectual Property Rights (IPRs); Essential, or potentially Essential, IPRs notified to ETSI in respect of ETSI standards*", which is available from the ETSI Secretariat. Latest updates are available on the ETSI Web server (<http://www.etsi.org/ipr>).

Pursuant to the ETSI IPR Policy, no investigation, including IPR searches, has been carried out by ETSI. No guarantee can be given as to the existence of other IPRs not referenced in SR 000 314 (or the updates on the ETSI Web server) which are, or may be, or may become, essential to the present document.

---

## Foreword

This European Standard (Telecommunications series) has been produced by European Computer Manufacturers Association (ECMA) on behalf of its members and those of the European Telecommunications Standards Institute (ETSI), and is now submitted for the Public Enquiry phase of the ETSI standards Two-step Approval Procedure.

<b>Proposed national transposition dates</b>	
Date of latest announcement of this EN (doa):	3 months after ETSI publication
Date of latest publication of new National Standard or endorsement of this EN (dop/e):	6 months after doa
Date of withdrawal of any conflicting National Standard (dow):	6 months after doa

---

## Brief History

The present document is one of a series of ECMA Standards defining services and signalling protocols applicable to Private Integrated Services Networks (PISNs). The series uses ISDN concepts as developed by ITU-T and the ATM Forum and is also within the framework of International Standards for Open Systems Interconnection as defined by ISO/IEC.

This particular standard specifies the circuit emulation functions for the emulation of a basic access over ATM. The present document specifies the static mapping of basic access information to ATM cells. Future enhancements may specify dynamic mapping functions.

The need for circuit emulation within ATM reflects a user demand for carrying certain types of constant bit rate (CBR) or "circuit" traffic over ATM networks. For the support of such types of traffic, ATM networks shall emulate circuit characteristics in order to provide good support for CBR traffic. A critical attribute of a circuit emulation service (CES) is that the performance realized over ATM should be comparable to that experienced with the current PDH/SDH technology.

Initial work on circuit emulation has been carried out by the ATM Forum subworking group VTOA leading to an approved interoperability specification, called CES-IS V2.0 (af-vtoa-0078.000). The CES-IS covers the following types of interfaces:

- 1) Structure DS1/E1 Nx64 kbit/s (Fractional DS1/E1) Service
- 2) Unstructured DS1/E1 (1.544 Mbit/s, 2.048 Mbit/s) Service
- 3) Unstructured DS3/E3 (44.736 Mbit/s, 34.368 Mbit/s) Service
- 4) Structured J2 Nx64 kbit/s (Fractional J2) Service
- 5) Unstructured J2 (6.312 Mbit/s) Service

The structured Nx64 and the unstructured DS1/E1/J2 services described in CES-IS V2.0 offer ways to connect DS1/E1/J2 equipment across emulated circuits carried on an ATM network.

Complementing the work of the ATM Forum, the present document provides for a circuit emulation service also for the N-ISDN basic access, allowing to connect such an access via an ATM connection to a PINX. The present document therefore follows the basic principles and the structure of the CES-IS of the ATM Forum.

In the same way as the CES-IS, it specifies static mapping functions performed by a CES-interworking function (IWF) between a basic access and an ATM connection, and the corresponding re-mapping between the ATM connection, and the link to the PINX.

The present document is based upon the practical experience of ECMA member companies and the results of their active and continuous participation in the work of ISO/IEC JTC1, ITU-T, ETSI and other international and national standardization bodies. It is also closely related to the Circuit Emulation Service Specification, Version 2, of the ATM Forum (af-vtoa-0078.000). It represents a pragmatic and widely based consensus.

---

## 1 Scope

The present document specifies the functions for the emulation of a basic access over ATM, thus providing an efficient way to connect existing N-ISDN terminal equipment to a PINX over a digital ATM section. Such an ATM connection can be either a (semi-)permanent connection, but might also be a switched virtual connection as defined in related ATM Forum specifications.

The objective of the present document therefore is to specify a mapping scheme for the three types of basic access information (two B channels: the B1 and B2 channels, the D channel as well as maintenance/control/status information) into ATM cells. Part of the maintenance/control/status information has to be terminated by an IWU and has to be substituted by other information applicable at the ATM connection. A reference configuration lays down that the point of emulation has to be placed at the network side of an extension line.

The present document specifies the static mapping of basic access information to ATM cells.

The present document complements the work of the ATM Forum on circuit emulation services for higher bandwidth.

The present document applies for private networks, however, it is also suitable for public networks.

---

## 2 Conformance

In order to conform to the present document, a circuit emulation functional unit shall satisfy the requirements identified in the Protocol Implementation Conformance Statement (PICS) proforma in annex A.

---

## 3 References

The following documents contain provisions which, through reference in this text, constitute provisions of the present document.

- References are either specific (identified by date of publication, edition number, version number, etc.) or non-specific.
- For a specific reference, subsequent revisions do not apply.
- For a non-specific reference, the latest version applies.
- A non-specific reference to an ETS shall also be taken to refer to later versions published as an EN with the same number.

- [1] ATM Forum: "UNI Signalling specification Version 4.0".
- [2] ATM Forum: "Circuit Emulation Service Interoperability Specification Version 2.0".
- [3] ISO/IEC 11579-1: "Information technology - Telecommunications and information exchange between systems - Private integrated services network - Part 1: Reference configuration for PISN Exchanges (PINX)".
- [4] ISO/IEC 11579-3: "Information technology - Private integrated services network - Part 3: Reference configuration for PINX extension lines".
- [5] ITU-T Recommendation G.960: "Access digital section for ISDN basic rate access".
- [6] ITU-T Recommendation I.363.1: "B-ISDN ATM Adaptation Layer specification: Type 1 AAL".
- [7] ITU-T Recommendation I.112: "Vocabulary of terms for ISDNs".

## 4 Definitions and abbreviations

### 4.1 External definitions

For the purposes of the present document, the following external terms and definitions apply.

**Integrated Services Digital Network (ISDN)** [7]

**Private Integrated Services Network (PISN)** [3]

**Private Integrated Services Network Exchange (PINX)** [3]

**Extension line** [4]

### 4.2 Special definitions

**Data Upstream (DU):** transmission of data from the CES-IWF to the PINX

**Data Downstream (DD):** transmission of data from the PINX to the CES-IWF

### 4.3 Abbreviations

For the purposes of the present document, the following abbreviations apply:

AAL	ATM Adaptation Layer
AI	Activation Indication
AR	Activation Request
ARL	Activation Request with local loop
ATM	Asynchronous Transfer Mode
CBR	Constant Bit Rate
CES	Circuit Emulation Service
CLP	Cell Loss Priority
DC	Deactivate Confirmation
DD	Data Downstream
DI	Deactivation Indication
DR	Deactivate Request
DU	Data Upstream
ISDN	Integrated Services Digital Network
IWF	Interworking Function
IWU	Interworking Unit
PCR	Peak Cell Rate
PET	Private network Exchange Termination
PICS	Protocol Implementation Conformance Statement
PINX	Private Integrated Services Network Exchange
PISN	Private Integrated Services Network
PTS	Private Termination System functional grouping
RES	RESet
RSY	ReSYnchronization
SDT	Structured Data Transfer
SW	SWitching functional grouping
TE	Terminal equipment
TIM	Timing required
TM	Test Mode
UAI	'U' only Activation Indication
UAR	'U' Activation Request
VTOA	Voice and telephony over ATM



## 5 Reference configuration

Figure 1 shows how a basic access circuit emulation by means of an ATM digital section corresponds to the reference configuration for PINX extension lines. As part of the PTS, the circuit emulation function resides at the PINX side of the extension line. A private exchange termination (PET) connects to an ATM interworking function 1 (ATM IWF 1) which performs the mapping of the basic access circuit mode channels to an ATM CBR channel. At the other end of the ATM digital section, a further ATM interworking function (ATM IWF 2) re-maps the ATM CBR to a PINX basic access. The two ATM IWFs insert the CBR link between the TE and the PINX. Signalling and user information sent by either the TE or the PINX are transported transparently through the intermediate ATM network. The circuit emulation function cares for bit integrity of both types of information.

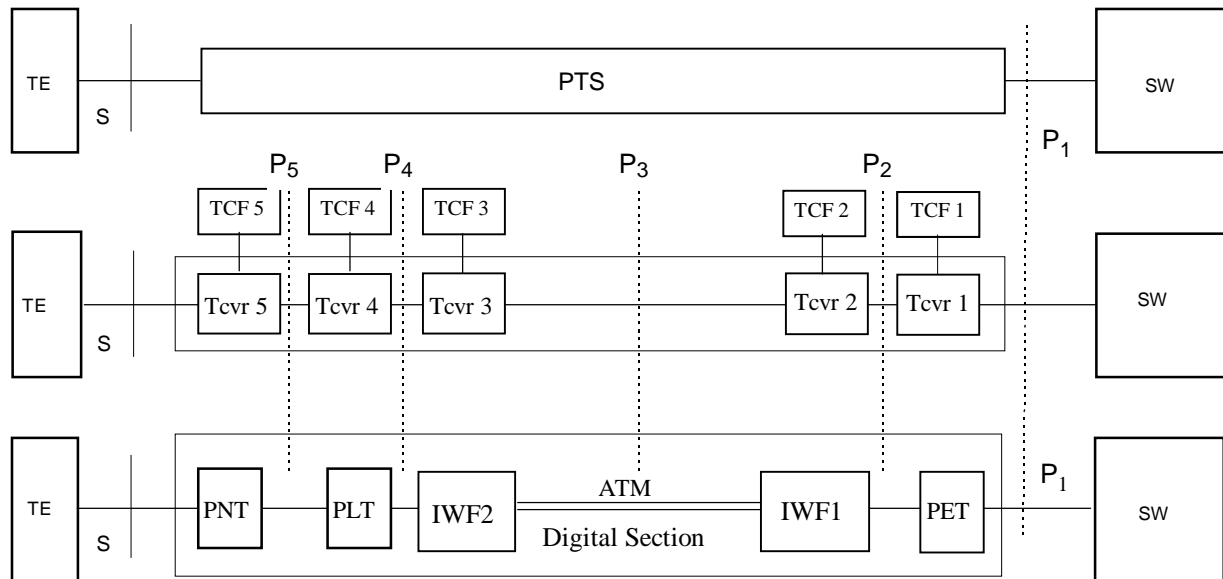

**Figure 1: Basic Access Circuit Emulation as part of the PTS**

Figure 2 shows an example how basic access in case of multiple N-TEs is supported by two virtual ATM channels..

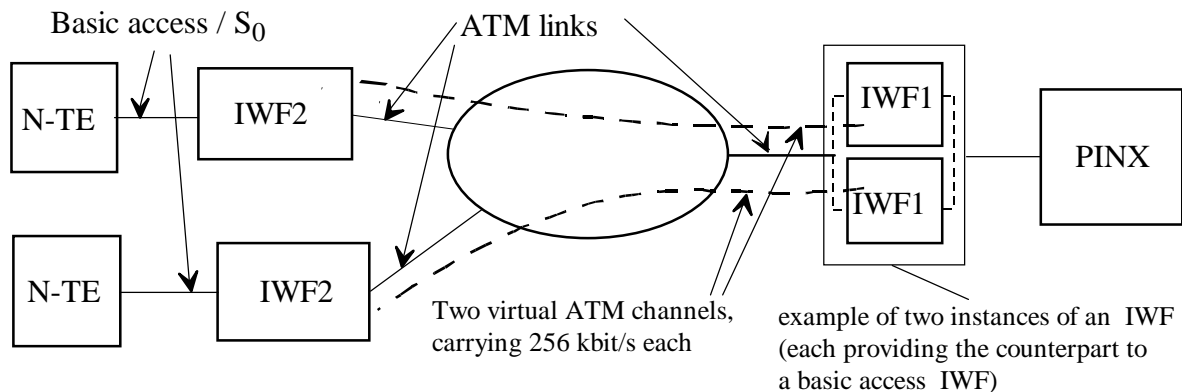

**Figure 2: Basic Access over ATM in case of multiple N-TEs**

## 6 Mapping functions

In order to transfer signalling and user information to/from a basic access, this information and the related OAM information shall be mapped into ATM cells. This shall be carried out in two steps. In the first step a mapping scheme shall provide for the mapping of the basic access structured bit stream into a fixed structure of 4 octets/32 Bits. In a second step shall provide for the mapping of such 4 octet/32 Bit strings into ATM cells.

The OAM and physical layer related information and the related functions are outlined in annex A. They are referred to as "CV1".

### 6.1 The mapping scheme

The mapping scheme for the basic access bit stream consisting of two B channels, a D channel and control data into a 4-octet block structure shall be as outlined in figure 3. The bit stream from a terminal is mapped into such a block by IWF2, and is remapped by the remote IWF1 before being transferred to the PINX, and vice versa.

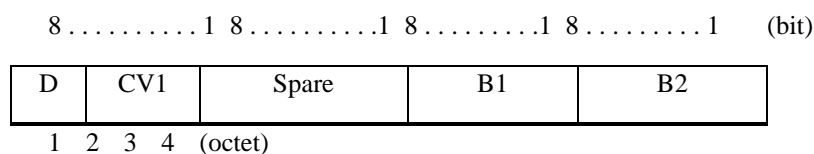

**Figure 3: The mapping scheme for basic access information**

Octets 1 through 4 shall carry the following bit streams:

- Octet 1: Bits 8,7: D-channel information
- Octet 1, Bits 6-1: CV1 information (see ITU-T Recommendation G.960 [5] and clause 6.3)
- Octet 2: the content and use are outside the scope of the present document (see note)
- Octet 3: B1 channel
- Octet 4: B2 channel

NOTE: Octet 2 can be used as a monitoring channel, as in public network applications.

### 6.2 Functions of the CV1 channel

The functions of the CV1 channel include:

- transfer of commands, status report information and defect conditions for each direction of transmission, as specified in annex A;
- controlling the initialization and transfer of data in octet 2, which can optionally be used as a monitoring channel. The procedures for this are specified in annex C.

### 6.3 Mapping of a 4-octet-block structure into ATM cells

The 4-octet block structure shall be mapped onto ATM cells using AAL type 1 (AAL-1) as specified in ITU-T Recommendation I.363.1 [6]. Within AAL-1, the SDT (structured data transfer) pointer, as specified in ITU-T Recommendation I.363.1 [6] shall be used.

AAL-1 with the SDT pointer leaves either 46 or 47 octets for its payload which is filled with the 4 octet blocks beginning with octet 1. All octets of the AAL-1 payload shall be filled completely, thus allowing a 4-octet-block to be spread across two consecutive ATM cells, e.g. the two first octets can appear at the end of one ATM cell, whereas the two last octets (B1, B2) will then appear in the following ATM cell, immediately starting after the AAL 1/SDT header octet(s).

## 7 ATM virtual channel requirements for basic access emulation

To support basic access emulation, ATM virtual channels shall be configured as specified in the following subclauses.

NOTE: If PVCs are used, the corresponding information will be set by management means.

### 7.1 ATM Peak Cell Rate (PCR)

The PCR on CLP = 0 + 1 required for AAL-1 transport of 256 kbit/s user data is 683 cells per second.

If the OAM traffic is to be included in the PCR per UNI 4.0, the OAM traffic parameter cells needs to be added to the above or specified separately.

### 7.2 Broadband Bearer Capability

Table 1 specifies the values for the fields in this information element.

**Table 1: Broadband Bearer Capability IE Field Values for CES SVCs**

Field	Value
Bearer Class	'1000 0' BCOB-X
Traffic Type	'001' Constant bit rate
Timing Requirements	'01' End-to-end timing required
Susceptibility to clipping	'00' Not susceptible to clipping
User Plane Connection Configuration	'00' Point-to-point

### 7.3 ATM Adaptation Layer Parameters

Table 2 specifies the field values for the Nx64 structured circuit emulation service. If the called party does not accept these parameters, it shall release the call in accordance with UNI 4.0 [1].

**Table 2: AAL Parameters IE Field Values for Nx64 structured Circuit Emulation Service SVCs**

Field	Value
AAL Type	'0000 0001' AAL Type 1
Subtype	'0000 0010' Circuit Transport
CBR rate	'0100 0000' N x 64 kbit/s, N >1
Multiplier	4
Structured Data Transfer Blocksize	4
Partially filled cells method	Partially filled cells method is not used

### 7.4 ATM Signalling/Call Establishment Procedures

The procedures for establishing the ATM connection between CES-IWF1 and CES-IWF2 are independent of the circuit emulation functions specified in the present document and are out of the scope of the present document.

## Annex A (normative): Contents and functions of the CV1 channel

The CV1 control channel facilitates the transfer of commands, status report information and defect conditions for each direction of transmission.

### A.1 Bit structure of the CV1 channel

The CV1 information is contained in octet 1, Bits 6 to 1 of the 4-octet structure defined in subclause 6.1. Its content is coded as indicated in figure A.1:

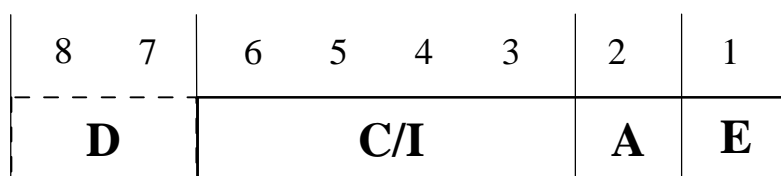

**Figure A.1: Bit structure of the CV1 channel**

Table A.1 shows the A Bit (Bit 2) and E Bit (Bit 1).

If the option to use octet 2 as a monitoring channel is not supported, the A and E bits shall be permanently set to binary ONE (Inactive state).

If the option is supported, the transitions of the A and E bit from active to inactive states as well as the persistence in a particular state shall be used as specified in annex C.

**Table A.1: Bit A and Bit B values**

Bit 2	Bit A	Bit 1	Bit E
0	Active ('A')	0	Active ('E')
1	Inactive (' $\bar{A}$ ')	1	Inactive (' $\bar{E}$ ')

### A.2 Command/Indication Channel Operation (C/I Channel)

The C/I channel carries real time status information and maintenance commands, as well as defect conditions. Maintenance commands include loopback requests and link activation/deactivation procedures.

The use of these commands and indications is an implementation option and outside the scope of the present document. However, if these commands and indications are used, they shall be coded as indicated in tables A.2 and A.3.

Table A.2 contains a glossary and encoding of the C/I channel commands for Data Upstream (DU).

Table A.3 contains a glossary and encoding of the C/I channel commands for Data Downstream (DD).

**Table A.2: C/I codes for Data Upstream**

<b>C/I Mnemonics Encoding</b>	<b>Description</b>
TIM: 0000	TIMing required: Requests GCI clock to be turned on.
RES: 0001	Reset: The downstream device is in the reset state. The 2B+D channels are set to IDLE.
RSY: 0100	Resynchronization: Device has lost capability to recognize line input signals. A recovery procedure is activated.
UAI: 0111	'U' only Activation Indication: 'U' transmission line is synchronous.
AR: 1000	Activation Request: Activation request from TE to ET.
AI: 1100	Activation Indication: The activation procedure has been successfully completed and layer 1 is activated to the TE. Transparent 2B+D transmission is now possible.
DI: 1111	Deactivation Indication: Acknowledges the execution of DR command (DD).

**Table A.3: C/I codes for Data Downstream**

<b>C/I Mnemonics Encoding</b>	<b>Description</b>
DR: 0000	Deactivate Request: Request to deactivate downstream devices/ interfaces.
RES: 0001	RESet: Software command which has the same effect as a hardware reset. The 2B+D channels are set to IDLE.
TM2: 0010	Test Mode 2: Special test mode for making line measurements.
TM1: 0011	Test Mode 1: Special test mode for making line measurements.
UAR: 0111	'U' Activation Request: Request to activate the 'U' interface between ET and NT.
AR: 1000	Activation Request: Request to activate layer 1 from ET to TE.
AR2: 1001	Activation Request with loop2: Request to activate U interface and perform a loop2 in NT.
ARL: 1010	Activation Request with local loop: Activate local loop.
AR4: 1011	Activation Request with loop4: Request to activate U interface between ET and RPT and perform a loop 4 in the repeater.
AI: 1100	Activation Indication: Indicates the ISDN activation procedure should proceed to transparent operation.
DC: 1111	Deactivate Confirmation: Acknowledgement to DI signal is sent by an upstream component to its immediate downstream component if applicable it can be used to enable wake up detect circuitry and power down any appropriate devices/ interfaces.

---

## Annex B (normative): Protocol Implementation Conformance Statement (PICS) Proforma

Notwithstanding the provisions of the copyright clause related to the text of the present document, ETSI grants that users of the present document may freely reproduce the PICS proforma in this annex so that it can be used for its intended purposes and may further publish the completed PICS.

---

### B.1 Introduction

The supplier of a protocol implementation which is claimed to conform to the present document shall complete the Protocol Implementation Conformance Statement (PICS) proforma in clause A.3.

A completed PICS proforma is the PICS for the implementation in question. The PICS is a statement of which capabilities and options of the protocol have been implemented. The PICS can have a number of uses, including use:

- by a protocol implementor, as a check list to reduce the risk of failure to conform to the standard through oversight;
- by the supplier and acquirer (or potential acquirer) of the implementation, as a detailed indication of the capabilities of the implementation, stated relative to the common basis for understanding provided by the standard PICS proforma;
- by the user (or potential user) of the implementation, as a basis for initially checking the possibility of interworking with another implementation (note that, while interworking can not be guaranteed, failure to interwork can often be predicted from incompatible PICSs);
- by a protocol tester, as the basis for selecting appropriate tests against which to assess the claim for conformance of the implementation.

---

### B.2 Instructions for completing the PICS proforma

#### B.2.1 General structure of the PICS proforma

The PICS proforma is a fixed format questionnaire divided into subclauses each containing a group of individual items. Each item is identified by an item number, the name of the item (question to be answered) and the reference(s) to the clause(s) that specifies (specify) the item in the main body of the present document.

The "Status" column indicates whether an item is applicable and if so whether support is mandatory or optional. The following terms are used:

m	mandatory (the capability is required for conformance to the protocol);
o	optional (the capability is not required for conformance to the protocol, but if the capability is implemented, it is required to conform to the protocol specifications);
o.<n>	optional, but support of at least one of the group of options labelled by the same numeral <n> is required;
x	prohibited;
c.<cond>	conditional requirement, depending on support for the item or items listed in condition <cond>;
<item>: m	simple conditional requirement, the capability being mandatory if item number <item> is supported, otherwise not applicable;

item>:o simple conditional requirement, the capability being optional if item number <item> is supported, otherwise not applicable.

Answers to the questionnaire items are to be provided either in the "Support" column, by simply marking an answer to indicate a restricted choice (Yes or No) or in the "Not Applicable" column (N/A).

## B.2.2 Additional information

Items of Additional Information allow a supplier to provide further information intended to assist the interpretation of the PICS. It is not intended or expected that a large quantity will be supplied, and a PICS can be considered complete without any such information. Examples might be an outline of the ways in which a (single) implementation can be set up to operate in a variety of environments and configurations.

References to items of Additional Information may be entered next to any answer in the questionnaire, and may be included in items of Exception information.

## B.2.3 Exception information

It may occasionally happen that a supplier will wish to answer an item with mandatory or prohibited status (after any conditions have been applied) in a way that conflicts with the indicated requirements. No pre-printed answer will be found in the Support column for this. Instead, the supplier is required to write into the support column an x.<i> reference to an item of Exception Information, and to provide the appropriate rationale in the Exception item itself.

An implementation for which an Exception item is required in this way does not conform to the present document. A possible reason for the situation described above is that a defect in the standard has been reported, a correction for which is expected to change the requirement not met by the implementation.

---

## B.3 PICS Proforma

### B.3.1 Implementation identification

Supplier	
Contact point for queries about the PICS	
Implementation name(s) and version(s)	
Other information necessary for full identification, e.g. name(s) and version(s) for machines and/or operating systems; system name(s)	

Only the first three items are required for all implementations; other information may be completed as appropriate in meeting the requirement for full identification.

The terms Name and Version should be interpreted appropriately to correspond with a suppliers terminology (e.g. Type, Series, Model).

### B.3.2 Protocol summary

Protocol version	1.0
Addenda Implemented (if applicable)	
Amendments Implemented	
Have any exception items been required (see A.2.3)?	No [ ] Yes [ ]  (The answer Yes means that the implementation does not conform to the present document)

Date of Statement	
-------------------	--

### B.3.3 General

Item	Name of Item	Reference	Status	N/A	Support
A1	Support of Mapping functions	7	m		m: Yes [ ]
A2	Support of ATM virtual channel requirements	8	m		m: Yes [ ]

### B.3.4 Procedures

Item	Name of Item	Reference	Status	N/A	Support
B1	Support of C/I channel procedures	7.3, clause A.2	m		m: Yes [ ]
B2	Support of the initialization and transfer procedure	7.3, annex C	o		o: Yes [ ] No [ ]

### B.3.5 Coding

Item	Name of Item	Reference	Status	N/A	Support
C1	Coding of C/I procedures	annex A	m		m: Yes [ ]



---

## Annex C (normative): The Monitor Channel Procedure

The E bit indicates the transfer of each new unit data in the direction from SW to CES-IWF and the A bit is used in the reverse direction to acknowledge this data unit transfer.

The transfer of data units in octet 2 is determined by transitions of both A and E bits from active to inactive states as well as persistence in a particular state.

---

### C.1 Idle

The A and E bit pair being held inactive for two or more frames constitutes the channel being idle in that direction.

---

### C.2 Start of Transmission

From the idle state the start of transmission is initiated by ET with the transition of the E bit from the inactive to the active state. The E bit remains active, and the data unit remains valid until an inactive-to-active transition of the A bit is received, indicating that the PTS/CES-IWF has received the data. Before transmitting the next data unit the ET detects the A bit transition from the inactive to active state. At the time the new data unit is transmitted, E is returned inactive for one frame time only, the data unit is valid in the same frame. In the following frame E returns active again and the same data unit is transmitted. Data is repeated in subsequent frame and E remains active until acknowledgement is detected (A transition from inactive to active). For the subsequent transmission see also figures C.2 and C.3.

---

### C.3 Reception of the First Data Unit

At the time the CES-IWF detects the first data unit, indicated by the inactive-to-active transition of E, A is by definition inactive. When the CES-IWF is ready to acknowledge the first data unit, it activates the A bit. Bit A remains active until the next data unit is received or an end of message is detected (bit E is held inactive for two or more frames).

---

### C.4 Subsequent Reception

The CES-IWF acknowledges the receipt of a valid data by the transition of A bit from the active to inactive state followed by the transition to the active state in the next frame. The reception of data is terminated by the receipt of an end-of-transmission indication (E bit remaining inactive for two or more frame times).

---

### C.5 End of Transmission (EOM)

The ET after receiving a successful last data unit acknowledge will indicate EOM by the transition of the E bit from the active to inactive state followed by the persistence of the inactive state for at least one or more frame.

---

### C.6 Abort

The abort is a signal from the CES-IWF to the TE indicating that data has been missed. It is not an abort in the classical sense, which is an indication from the transmitter that the current message should be ignored. The CES-IWF indicates an abort by holding A inactive for two or more frames in response to E bit going active.

Figure C.1 depicts the information flows for the initialization and transfer procedure.

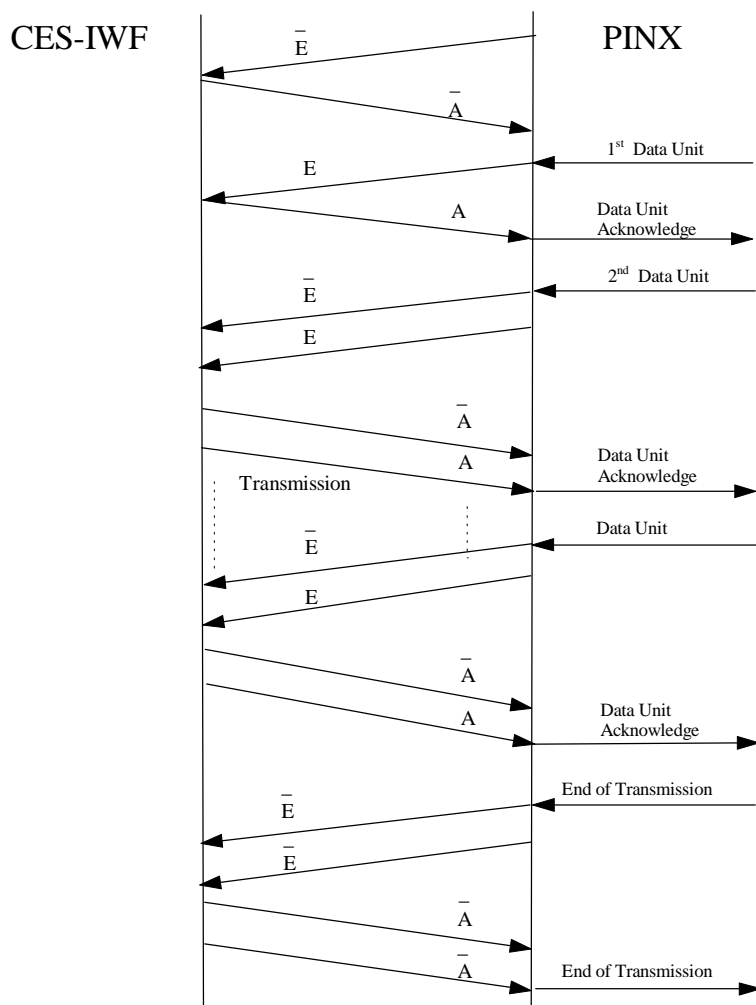

Figure C.1: Initialization and transfer procedure

Figure C.2 depicts the timing of the initialization and transfer procedure.

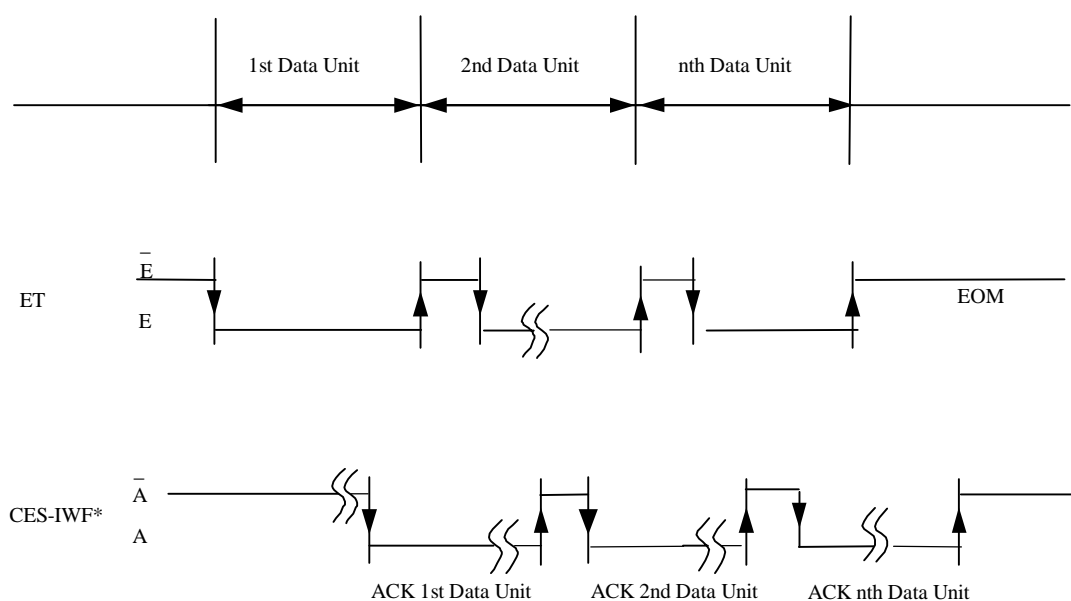
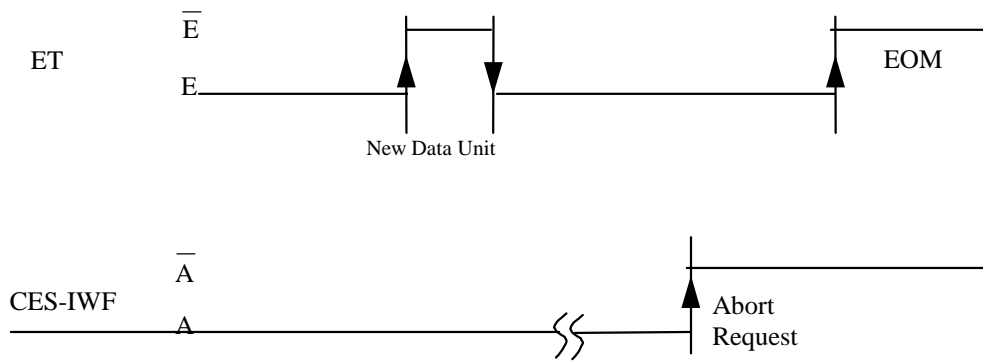

Figure C.2: Initialization and Transfer Timing

Figure C.3 depicts an Abort Request from the receiver.



**Figure C.3: Abort Request from the Receiver**

---

## Bibliography

The following material, though not specifically referenced in the body of the present document (or not publicly available), gives supporting information.

- CCITT Recommendation I.412: "ISDN user-network interfaces – Interface structures and access capabilities".
- ITU-T Recommendation I.430: "Basic user-network interface - Layer 1 specification".
- ITU-T Recommendation Q.512: "Digital exchange interfaces for subscriber access".

---

## History

<b>Document history</b>		
V1.1.1	October 1999	Public Enquiry PE 200008: 1999-10-27 to 2000-02-25