

Final draft **ETSI EN 301 460-1** V1.1.1 (2000-08)

European Standard (Telecommunications series)

**Fixed Radio Systems;
Point-to-multipoint equipment;
Part 1: Point-to-multipoint digital radio systems
below 1 GHz - Common parameters**



Reference

DENTM-04055-1

Keywords

DRRS, FWA, multipoint, radio, RLL

ETSI

650 Route des Lucioles
F-06921 Sophia Antipolis Cedex - FRANCE

Tel.: +33 4 92 94 42 00 Fax: +33 4 93 65 47 16

Siret N° 348 623 562 00017 - NAF 742 C
Association à but non lucratif enregistrée à la
Sous-Préfecture de Grasse (06) N° 7803/88

Important notice

Individual copies of the present document can be downloaded from:
<http://www.etsi.org>

The present document may be made available in more than one electronic version or in print. In any case of existing or perceived difference in contents between such versions, the reference version is the Portable Document Format (PDF). In case of dispute, the reference shall be the printing on ETSI printers of the PDF version kept on a specific network drive within ETSI Secretariat.

Users of the present document should be aware that the document may be subject to revision or change of status. Information on the current status of this and other ETSI documents is available at <http://www.etsi.org/tb/status/>

If you find errors in the present document, send your comment to:
editor@etsi.fr

Copyright Notification

No part may be reproduced except as authorized by written permission.
The copyright and the foregoing restriction extend to reproduction in all media.

© European Telecommunications Standards Institute 2000.
All rights reserved.

Contents

Intellectual Property Rights.....	5
Foreword	5
Introduction.....	6
1 Scope.....	7
1.1 Applications	7
1.2 Frequencies	8
2 References.....	8
3 Definitions, symbols and abbreviations	10
3.1 Definitions	10
3.2 Symbols	10
3.3 Abbreviations.....	10
4 General characteristics	11
4.1 General system architecture	11
4.2 Frequency bands and channel arrangements.....	12
4.2.1 Channel plan.....	12
4.2.2 Duplex methods.....	12
4.3 Compatibility requirements.....	12
4.4 Transmission error performance	12
4.5 Environmental conditions	12
4.5.1 Equipment within weather protected locations (indoor locations)	12
4.5.2 Equipment for non weather-protected locations (outdoor locations)	13
4.6 Power supply.....	13
4.7 Electromagnetic compatibility	13
4.8 TMN interfaces	13
4.9 Synchronization of interface bit rates	13
4.10 Branching / feeder / antenna requirements.....	13
4.10.1 Antenna radiation pattern	13
4.10.2 Antenna port characteristics	13
4.10.2.1 RF interface	13
4.10.2.2 Return loss	13
5 System parameters	14
5.1 System capacity	14
5.2 Round trip delay.....	14
5.3 Transparency.....	14
5.4 Voice coding methods.....	14
5.5 Transmitter characteristics	14
5.5.1 Transmitter output power	15
5.5.2 Automatic Transmit Power Control (ATPC).....	15
5.5.3 Tx Local Oscillator (LO) frequency arrangements	15
5.5.4 RF spectrum mask	15
5.5.5 Radio frequency tolerance	15
5.5.6 Spurious emissions	16
5.6 Receiver characteristics	16
5.6.1 Input level range.....	16
5.6.2 Spurious emissions	16
5.7 System performance.....	16
5.7.1 Dynamic level range.....	16
5.7.2 BER as a function of RSL	16
5.7.3 Interference sensitivity (external).....	16
5.7.3.1 Co-channel interference.....	16
5.7.3.2 Adjacent channel interference	16
5.7.4 Distortion sensitivity	16
5.7.5 CW interference	17

5.7.6	Two tone interference.....	17
5.7.7	Impulsive interference.....	17
6	Types of interfaces at the subscriber equipment and the network exchange	17
Annex A (informative):	Impulsive interference.....	18
	Bibliography.....	19
	History.....	20

Intellectual Property Rights

IPRs essential or potentially essential to the present document may have been declared to ETSI. The information pertaining to these essential IPRs, if any, is publicly available for **ETSI members and non-members**, and can be found in ETSI SR 000 314: "*Intellectual Property Rights (IPRs); Essential, or potentially Essential, IPRs notified to ETSI in respect of ETSI standards*", which is available from the ETSI Secretariat. Latest updates are available on the ETSI Web server (<http://www.etsi.org/ipr>).

Pursuant to the ETSI IPR Policy, no investigation, including IPR searches, has been carried out by ETSI. No guarantee can be given as to the existence of other IPRs not referenced in ETSI SR 000 314 (or the updates on the ETSI Web server) which are, or may be, or may become, essential to the present document.

Foreword

This European Standard (Telecommunications series) has been produced by ETSI Technical Committee Transmission and Multiplexing (TM), and is now submitted for the Vote phase of the ETSI standards Two-step Approval Procedure.

The present document is part 1 of a multi-part deliverable covering the Fixed Radio Systems; Point-to-multipoint equipment, as identified below:

- Part 1:** "Point-to-multipoint digital radio systems below 1 GHz - Common parameters";
- Part 2: "Point-to-multipoint digital radio systems below 1 GHz - Additional parameters for TDMA systems";
- Part 3: "Point-to-multipoint digital radio systems below 1 GHz - Additional parameters for FH-CDMA systems";
- Part 4: "Point-to-multipoint digital radio systems below 1 GHz - Additional parameters for FDMA systems";
- Part 5: "Point-to-multipoint digital radio systems below 1 GHz - Additional parameters for DS-CDMA systems".

Proposed national transposition dates	
Date of latest announcement of this EN (doa):	3 months after ETSI publication
Date of latest publication of new National Standard or endorsement of this EN (dop/e):	6 months after doa
Date of withdrawal of any conflicting National Standard (dow):	6 months after doa

Introduction

The main field of application of Point-to-Multipoint (P-MP) systems, in the Fixed Service (FS), is to provide access to both public and private networks (PSTN, PDN,...). By means of P-MP systems the network service area may cover scattered subscriber locations. The systems may be applied to build new access networks by means of a multi cellular architecture, covering primarily rural areas.

Users are offered the full range of services by the particular public or private network. Users have access to these services by means of the various standardized user network interfaces (e.g. 2-wire loop, and ISDN basic rate).

Point-to-Multipoint (P-MP) systems provide standard network interfaces and transparently connect users to the appropriate network node. These systems allow a service to be connected to a number of users ranging from a few to several hundred, and over a wide range of distances.

P-MP systems are generally configured as Pre-Assigned Multiple Access (PAMA) Systems or as Demand Assigned Multiple Access (DAMA) Radio Systems.

The essential features of a typical P-MP Radio System are:

- efficient use of the radio spectrum;
- concentration;
- transparency.

Radio is often the ideal way of obtaining communications at low cost and almost independent of distance, and over difficult topography. Moreover, a small number of sites are required for these installations, thus facilitating rapid implementation and minimizing maintenance requirements of the systems.

Concentration means that m users can share n radio channels (m being larger than n), allowing a better use of the available frequency spectrum at lower equipment costs. The term "multi-access" means that every user has access to every channel (instead of a fixed assignment as in most multiplex systems). When a demand arises, an available channel is allocated to it. When the demand is terminated, the channel is released for other users.

Concentration requires the use of distributed intelligent control which in turn allows many other operation and maintenance functions to be added.

Transparency means that the service node and the user terminal communicates with each other without being aware of the radio path.

1 Scope

1.1 Applications

The present document specifies the minimum requirements for system parameters of Point-to-Multipoint (P-MP) Radio Systems in the Fixed Services operating below 1 GHz.

The system will provide access to both public and private networks (PSTN, PDN...) by means of the various standardized network interfaces (e.g. 2-wire loop, ISDN).

The system may be applied to build access networks by means of a multi cellular architecture, covering rural areas. An important requirement for rural areas is the ability to cope with non line of sight conditions.

A rural area may be defined by the following 3 characteristics:

- 1) telephone density of 0,01 to 1 telephone per km²;
- 2) connection distance from the telephone to the PSTN is tens of kms. This backhaul distance can be served by copper, point to point microwave or in a convenient way as part of a Point to Multipoint system;
- 3) difficult access to the region due to poor infrastructure such as roads. This may be caused by lack of proper infrastructure or simply a difficult terrain in which the infrastructure is deployed. Hills, lakes, trees, rivers and varying climatic conditions can all account for this difficulty of access and propagation.

Point-to-Multipoint Radio-Relay Systems (P-MP) use, in principle, different access methods, taking into account the basic physical parameters of frequency, code and time. This leads to the basic access methods of:

- Time Division Multiple Access (TDMA);
- Frequency Hopping Code Division Multiple Access (FH CDMA);
- Frequency Division Multiple Access (FDMA);
- Direct Sequence Code Division Multiple Access (DS-CDMA).

As some technical parameters are different for the various access methods the present document is divided in five parts (see forward).

Parts 2, 3, 4 and 5 should be used in conjunction with Part 1, describing the basic parameters common to all access methods.

A basic description of the different access methods and a comparison among them is provided in TR 101 274 [19].

The present document covers the following typical Point-to-Multipoint (P-MP) applications, delivered directly or indirectly, or in any superimposed transport network layer, including internet multiple access:

the transmission of:

- voice;
- fax;
- voice band data;

related to analogue interfaces and:

- data;
- ISDN BA (2B + D);

related to digital interfaces.

The present document defines the requirements of radio terminal and radio-relay equipment including the interfaces. The requirements for multiplex, network management and antenna/feeder equipment may be addressed elsewhere.

1.2 Frequencies

CEPT FM has pointed out that frequency bands below 1 GHz could be allowed for fixed service applications on a national basis for remote and rural areas. These decisions have also been reflected in the European Common Allocation table, CEPT/ERC Report 025 [24]. A European footnote (EU 7) has been added to the notes column in the bands 146 MHz to 174 MHz, 335,4 MHz to 380 MHz, 440 MHz to 470 MHz. Besides these frequency bands, the present document may be referred to for equipment operated in other frequency bands below 1 GHz.

2 References

The following documents contain provisions which, through reference in this text, constitute provisions of the present document.

- References are either specific (identified by date of publication, edition number, version number, etc.) or non-specific.
- For a specific reference, subsequent revisions do not apply.
- For a non-specific reference, the latest version applies.
- A non-specific reference to an ETS shall also be taken to refer to later versions published as an EN with the same number.

- [1] ITU-R Recommendation F.697-2: "Error performance and availability objectives for the local-grade portion at each end of an ISDN connection at a bit rate below the primary rate utilizing digital radio-relay systems".
- [2] ETSI ETS 300 132 (Parts 1 and 2): "Equipment Engineering (EE); Power supply interface at the input to telecommunications equipment; Part 1: Operated by alternating current (ac) derived from direct current (dc) sources; and; Part 2: Operated by direct current (dc)".
- [3] ETSI EN 300 385: "Electromagnetic compatibility and Radio spectrum Matters (ERM); ElectroMagnetic Compatibility (EMC) standard for fixed radio links and ancillary equipment".
- [4] ITU-T Recommendation G.773: "Protocol suites for Q-interfaces for management of transmission systems".
- [5] CCITT Recommendation G.711: "Pulse code modulation (PCM) of voice frequencies".
- [6] ITU-T Recommendation G.703: "Physical/electrical characteristics of hierarchical digital interfaces".
- [7] ITU-T Recommendation G.961: "Digital transmission system on metallic local lines for ISDN basic rate access".
- [8] ITU-T Recommendation G.964: "V-Interfaces at the digital local exchange (LE) – V5.1-interface (based on 2 048 kbit/s) for the support of access network (AN)".
- [9] ITU-T Recommendation G.965: "V-Interfaces at the digital local exchange (LE) – V5.2 Interface (based on 2 048 kbit/s) for the support of access network (AN)".
- [10] ETSI ETS 300 012: "Integrated Services Digital Network (ISDN); Basic user-network interface; Layer 1 specification and test principles".
- [11] ETSI EN 300 324 (all parts): "V interfaces at the digital Local Exchange (LE); V5.1 interface for the support of Access Network (AN)".
- [12] ETSI EN 300 347: "V interfaces at the digital Local Exchange (LE); V5.2 interface for the support of Access Network (AN)".
- [13] ITU-T Recommendation G.810: "Definitions and terminology for synchronization networks".

- [14] ITU-T Recommendation G.821: "Error performance of an international digital connection operating at a bit rate below the primary rate and forming part of an integrated services digital network".
- [15] ITU-T Recommendation G.131: "Control of talker echo".
- [16] ITU-T Recommendation G.726: "40, 32, 24, 16 kbit/s Adaptive Differential Pulse Code Modulation (ADPCM)".
- [17] ITU-T Recommendation G.728: "Coding of speech at 16 kbit/s using low-delay code excited linear prediction".
- [18] ITU-T Recommendation G.729: "Coding of speech at 8 kbit/s using Conjugate-Structure Algebraic-Code-Excited-Linear-Prediction (CS-ACELP)".
- [19] ETSI TR 101 274: "Transmission and Multiplexing (TM); Digital Radio Relay Systems (DRRS); Point-to-multipoint DRRS in the access network: Overview of different access techniques".
- [20] CEPT/ERC Recommendation 74-01: "Spurious emissions".
- [21] ISO/IEC 8802-3 (1996): "Information technology - Telecommunications and information exchange between systems - Local and metropolitan area networks - Specific requirements - Part 3: Carrier sense multiple access with collision detection (CSMA/CD) access method and physical layer specifications".
- [22] ITU-T Recommendation G.723.1: "Dual rate speech coder for multimedia communications transmitting at 5.3 and 6.3 kbit/s".
- [23] ETSI EG 201 188: "Public Switched Telephone Network (PSTN); Network Termination Point (NTP) analogue interface; Specification of physical and electrical characteristics at a 2-wire analogue presented NTP for short to medium length loop applications".
- [24] CEPT/ERC Report 025: "Frequency band 29,7 MHz to 105 GHz and associated European table of frequency allocations and utilizations".
- [25] ITU-R Recommendation SM.1045-1: "Frequency tolerance of transmitters".
- [26] ETSI ETS 300 019 (all parts): "Equipment Engineering (EE); Environmental conditions and environmental tests for telecommunications equipment".
- [27] IEC 60169-3: "Radio-frequency connectors. Part 3: Two-pin connector for twin balanced aerial feeders".
- [28] IEC 60339 (Parts 1 and 2): "General purpose rigid coaxial transmission lines and their associated flange connectors. Part 1: General requirements and measuring methods; and; Part 2: Detail specifications".
- [29] Commission Directive 95/54/EC concerning the adaptation to technical progress of Council Directive 72/245/EEC and amending Directive 70/156/EEC relating to the type-approval of motor vehicles and their trailers: OJ L 266, 1995.
- [30] ITU-R Recommendation I.376: "ISDN network capabilities for the support of teleaction service".
- [31] ITU-T Recommendation Q.552: "Transmission characteristics at 2-wire analogue interfaces of digital exchanges".
- [32] ITU-T Recommendation Q.553: "Transmission characteristics at 4-wire analogue interfaces of digital exchanges".
- [33] ITU-R: "Radio Regulations, Geneva".
- [34] ETSI EN 301 460-2: "Fixed Radio Systems Point-to-multipoint equipment Part 2: Point-to-multipoint digital radio systems below 1 GHz - Additional parameters for TDMA systems".
- [35] ETSI EN 301 460-3: "Fixed Radio Systems; Point-to-multipoint equipment; Part 3: Point-to-multipoint digital radio systems below 1 GHz - Additional parameters for FH-CDMA systems".

- [36] ETSI EN 301 460-4: "Fixed Radio Systems Point-to-multipoint equipment; Part 4: Point-to-multipoint digital radio systems below 1 GHz - Additional parameters for FDMA systems".
- [37] ETSI EN 301 460-5: "Fixed Radio Systems; Point-to-multipoint equipment; Part 5: Point-to-multipoint digital radio systems below 1 GHz - Additional parameters for DS-CDMA systems".
- [38] ITU-R Recommendation P.372-6: "Radio noise".

3 Definitions, symbols and abbreviations

3.1 Definitions

For the purposes of the present document, the following terms and definitions apply.

Full Capacity Load (FCL): is defined by the maximum number of 64 kbit/s signals or the equivalent which can be transmitted and received by a single CS within a specified RF-bandwidth, fulfilling a given performance and availability objectives in respect to fading conditions

the round trip delay: is defined as the sum of the delay between point F to G plus G to F in figure 1 including any repeaters as appropriate

3.2 Symbols

For the purposes of the present document, the following symbols apply:

dB	decibel
dBm	decibel relative to 1 mW
GHz	GigaHertz
km	kilometre
Mbit/s	Megabit per second
MHz	MegaHertz
ns	nanosecond
ppm	parts per million

3.3 Abbreviations

For the purposes of the present document, the following abbreviations apply:

ATPC	Automatic Transmit Power Control
BA	Broadcast Control CHannel Allocation
BER	Bit Error Rate
CCS	Central Controller Station
CRS	Central Radio Station
CS	Central Station
CW	Continuous Wave
DAMA	Demand Assigned Multiple Access
DS-CDMA	Direct Sequence Code Division Multiple Access
EMC	ElectroMagnetic Compatibility
FCL	Full Capacity Load
FDD	Frequency Division Duplex
FDMA	Frequency Division Multiple Access
FH	Frequency Hopping
FH-CDMA	Frequency Hopping Code Division Multiple Access
ISDN	Integrated Service Digital Network
ITU	International Telecommunications Union
LO	Local Oscillator
MOS	Mean Opinion Score
P-MP	Point to Multipoint

PSTN	Public Switched Telephone Network
QDU	Quantization Distortion Unit
RF	Radio Frequency
RS	Repeater Station
RSL	Receive Signal Level
Rx	Receiver
TDD	Time Division Duplex
TDMA	Time Division Multiple Access
TE	Terminal Equipment
TM	Transmission and Multiplex
TMN	Telecommunications Management Network
TS	Terminal Station
Tx	Transmitter

4 General characteristics

4.1 General system architecture

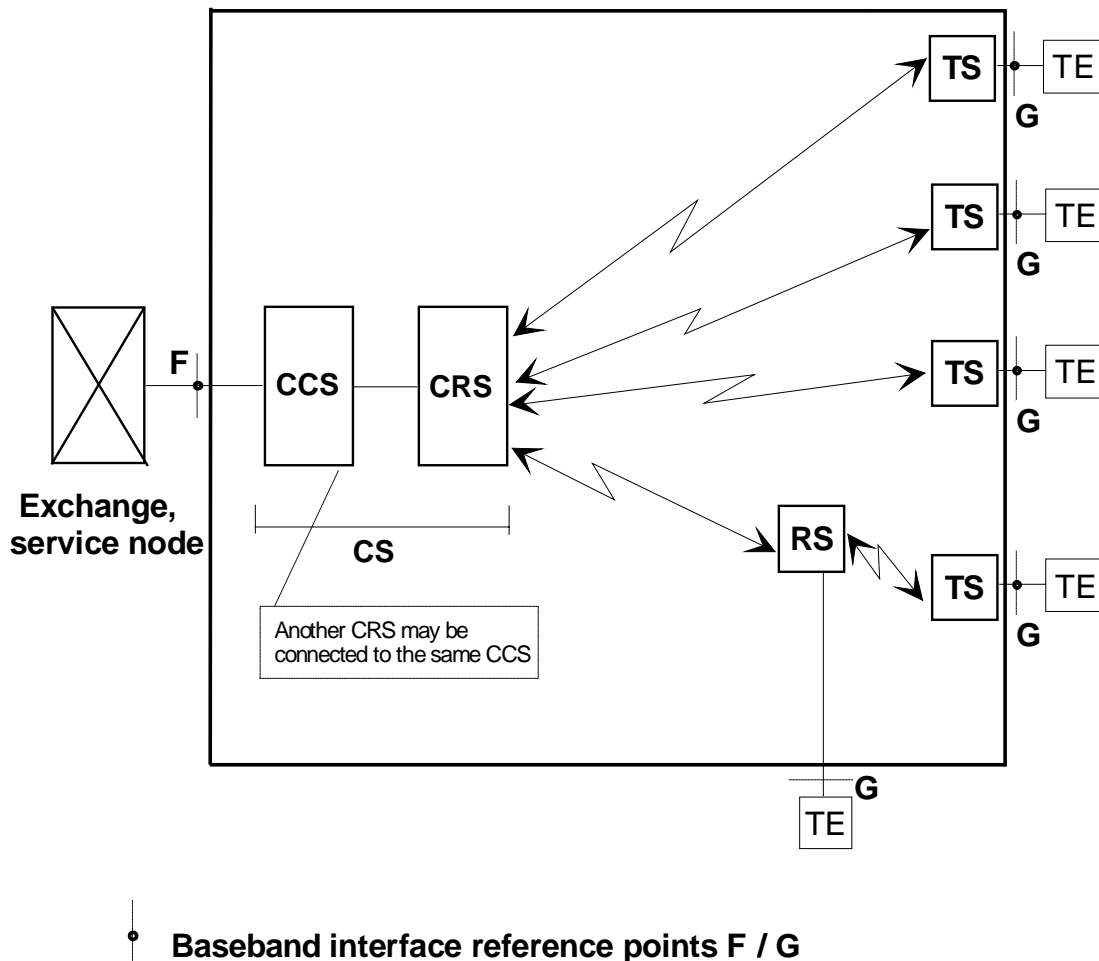

NOTE 1: A CRS may be equipped with more than one transceiver.

NOTE 2: Central Controller Station (CCS) may control more than one Central Radio Station (CRS).

NOTE 3: A TS may serve more than one TE.

Figure 1: General system architecture

The central station performs the interconnection with the local switching exchange (service node) carrying out a concentration function by sharing the total number of available channels in the system. The central station is linked either directly to all Terminal Stations (TS) or via a Repeater Station (RS) by radio transmission paths. Whenever an existing digital transmission link is available, the network radio implementation can be optimized by separating the CCS installed at the exchange site and the CRS.

4.2 Frequency bands and channel arrangements

Possible frequency bands below 1 GHz, which could be used for rural P-MP applications on a national basis are e.g. those under the provision of note EU 7 of CEPT/ERC Report 025 [24] table 1 shows possible frequency bands below 1 GHz, which could be used for rural P-MP applications on a national basis. Other frequency bands might also be used.

Table 1: Frequency bands

Frequency band
146 MHz to 174 MHz
335,4 MHz to 380 MHz
410 MHz to 430 MHz
440 MHz to 470 MHz
870 MHz to 890 MHz / 915 MHz to 935 MHz

4.2.1 Channel plan

Channel plans shall be consistent with national allocations and constraints.

4.2.2 Duplex methods

FDD or TDD duplex methods may be used.

4.3 Compatibility requirements

There is no requirement to operate the CS from one manufacturer with the TS and RS from another manufacturer.

4.4 Transmission error performance

The equipment covered by the present document should be designed to be able to meet the network performance requirements foreseen by ITU-R Recommendations F.697-2 [1], local grade national portion (access or short haul) of the digital connection following the criteria defined in ITU-T Recommendation G.821 [14].

4.5 Environmental conditions

The equipment shall be required to meet the environmental conditions set out in ETS 300 019 [26] which defines weather protected and non-weather protected locations, classes and test severity.

The manufacturer shall state which class the equipment is designed to withstand.

4.5.1 Equipment within weather protected locations (indoor locations)

The equipment intended for operation within temperature controlled locations or partially temperature controlled locations shall meet the requirements of ETS 300 019 [26] classes 3.1 and 3.2 respectively.

Optionally, the more stringent requirements of ETS 300 019 [26] classes 3.3 (Non temperature controlled locations), 3.4 (Sites with heat trap) and 3.5 (Sheltered locations) may be applied.

4.5.2 Equipment for non weather-protected locations (outdoor locations)

Equipment intended for operation in non-weather protected locations shall meet the requirements of ETS 300 019 [26], class 4.1 or 4.1E.

Class 4.1 applies to many ETSI countries and class 4.1E applies to all ETSI countries.

For systems supplied within a specific radio cabinets which gives full protection against precipitation, wind, etc. the ETS 300 019 [26] classes 3.3, 3.4 and 3.5 may be applied also for equipment intended for operation in non-weather protected locations.

4.6 Power supply

If the power supply operates at one or more nominal voltage ranges foreseen by ETS 300 132 [2], then the power supply interface shall be in accordance with the corresponding parts of that ETS. For 230 V AC and 48 V DC the interfaces shall be in accordance with the characteristics foreseen by ETS 300 132 [2] part 1 and part 2, respectively.

NOTE: Some applications may require power supply voltage ranges that are not covered by ETS 300 132 [2].

4.7 Electromagnetic compatibility

Fixed Service equipment shall operate under the conditions specified in EN 300 385 [3].

4.8 TMN interfaces

TMN interface, if any, shall be in accordance with ITU-T Recommendation G.773 [4].

4.9 Synchronization of interface bit rates

Systems employing digital interfaces shall include methods enabling internal and external synchronization to the network. Synchronization tolerance should meet the requirements of ITU-T Recommendations G.810 [13] and G.703 [6].

4.10 Branching / feeder / antenna requirements

4.10.1 Antenna radiation pattern

Void.

4.10.2 Antenna port characteristics

4.10.2.1 RF interface

If the RF interface (points C and C' in figure 2) is accessible it shall be coaxial 50 Ω type. The connector shall conform with IEC 60169-3 [27] or IEC 60339 [28].

4.10.2.2 Return loss

If the RF is accessible (points C and C' in figure 2), the return loss at those points shall be more than 10 dB at the reference impedance.

5 System parameters

5.1 System capacity

The system capacity parameter considered in the present document is the transmission capacity of the CS, which is the maximal payload bit rate transmitted over the air between a given CS and its associated remote stations (TSs and RSs). The manufacturer shall declare the system capacity.

5.2 Round trip delay

The round trip delay for a 64 kbit/s traffic channel shall not exceed 20 ms.

Longer round trip delays may result at other bit rates and when using speech coding at rates lower than 64 kbit/s. In order to guarantee that the delay, introduced by the system into the transmission network does not degrade the quality of the telephone communication, compliance to ITU-T Recommendation G.131 [15] shall be ensured.

5.3 Transparency

The system shall be fully transparent: the network node and the subscriber equipment (points F and G in figure 1) communicate with each other without being aware of the radio link.

5.4 Voice coding methods

One of the following coding methods should be used:

- 64 kbit/s CCITT Recommendation G.711 [5];
- 32 kbit/s ITU-T Recommendation G.726 [16];
- 16 kbit/s ITU-T Recommendation G.728 [17];
- 8 kbit/s ITU-T Recommendation G.729 [18];
- 5,3 kbit/s to 6,3 kbit/s ITU-T Recommendation G.723.1 [22].

Other voice coding methods may be employed if the quality, (measured for example in Quantization Distortion Units (QDU) or Mean Opinion Score (MOS) shall be equivalent to the above.

5.5 Transmitter characteristics

All transmitter characteristics are referred to a system under any traffic load conditions.

The values and measurements are referred to point C' of figure 2.

Measurements shall be made when the CRS (at least one transceiver equipment) is under full load conditions, to be declared by the manufacturer.

A BER lower than or equal to 10^{-6} shall be achieved at a receive signal level stated in subclause 5.7.2.

The specified transmitter characteristics shall be met with the appropriate input signals applied at point A or B of figure 2.

The RF-System block diagram shows the point to point connection of the P-MP transceiver between the CRS and one TS and vice versa, as illustrated in figure 2.

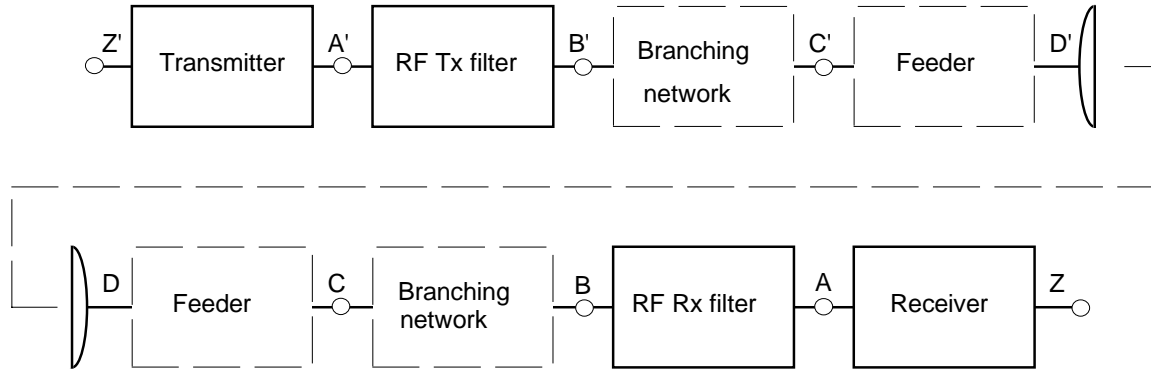

NOTE: The points shown above are reference points only; points B, C and D, B', C' and D' may coincide.

Figure 2: RF-system block diagram

5.5.1 Transmitter output power

The maximum mean transmitter output power (average, for CRS, RS and TS) shall not exceed +43 dBm. Care shall be taken that the system EIRP defined in the Radio Regulations [33] is not exceeded.

5.5.2 Automatic Transmit Power Control (ATPC)

ATPC is considered to be an optional feature. Equipment with ATPC will be subject to manufacturer declaration of the ATPC ranges and related tolerances. Testing shall be carried out with output power level corresponding to:

- ATPC set manually to a fixed value for system performance;
- ATPC set at maximum provided power for Tx performance.

5.5.3 Tx Local Oscillator (LO) frequency arrangements

There is no requirement on Tx LO frequency arrangement.

5.5.4 RF spectrum mask

These parameters are dependant of the access method. It is specified in EN 301 460-2 [34] for TSMA, EN 301 460-3 [35] for FH-CDMA, EN 301 460-4 [36] for FDMA and EN 301 460-5 [37] for DS-CDMA.

5.5.5 Radio frequency tolerance

Radio frequency tolerance should, in principle, meet the achievable requirement of ITU-R Recommendation SM.1045-1 [25], as defined for fixed stations in the appropriate band, however, considering the relatively wide assigned frequency band required by the systems under consideration, a frequency tolerance up to ± 20 ppm is still appropriate and may be agreed with the administration concerned. This limit includes both short-term factors and long-term ageing effects. For the purpose of type testing the manufacturer shall state the guaranteed short-term part and the expected ageing part.

5.5.6 Spurious emissions

According to CEPT/ERC Recommendation 74-01 [20] the spurious emissions are defined as emissions at frequencies which are removed from the nominal carrier frequency more than $\pm 250\%$ of the channel separation. Outside the band of $\pm 250\%$ of the relevant channel separation (CS), the Fixed Service radio systems spurious emission limits defined by CEPT/ERC Recommendation 74-01 [20] together with the frequency range to consider for conformance measurement, shall apply at reference point C.

5.6 Receiver characteristics

5.6.1 Input level range

This parameters are dependant of the access method. It is specified in EN 301 460-2 [34] for TSMA, EN 301 460-3 [35] for FH-CDMA, EN 301 460-4 [36] for FDMA and EN 301 460-5 [37] for DS-CDMA.

5.6.2 Spurious emissions

At reference point C, the limits values of CEPT/ERC Recommendation 74-01 [20] shall apply.

5.7 System performance

The parameters stated below shall be met under any load condition.

All parameters are referred to reference point B or C of the RF-System block diagram (figure 2).

5.7.1 Dynamic level range

These parameters are dependant of the access method. It is specified in EN 301 460-2 [34] for TSMA, EN 301 460-3 [35] for FH-CDMA, EN 301 460-4 [36] for FDMA and EN 301 460-5 [37] for DS-CDMA.

5.7.2 BER as a function of RSL

These parameters are dependant of the access method. It is specified in EN 301 460-2 [34] for TSMA, EN 301 460-3 [35] for FH-CDMA, EN 301 460-4 [36] for FDMA and EN 301 460-5 [37] for DS-CDMA.

5.7.3 Interference sensitivity (external)

All receive signal levels and S/I measurements are defined in EN 301 460-2 [34] for TSMA, EN 301 460-3 [35] for FH-CDMA, EN 301 460-4 [36] for FDMA and EN 301 460-5 [37] for DS-CDMA.

5.7.3.1 Co-channel interference

The limits of co-channel interference (external) shall be as defined in EN 301 460-2 [34] for TSMA, EN 301 460-3 [35] for FH-CDMA, EN 301 460-4 [36] for FDMA and EN 301 460-5 [37] for DS-CDMA.

5.7.3.2 Adjacent channel interference

The limits of adjacent channel interference shall be as defined in EN 301 460-2 [34] for TSMA, EN 301 460-3 [35] for FH-CDMA, EN 301 460-4 [36] for FDMA and EN 301 460-5 [37] for DS-CDMA.

5.7.4 Distortion sensitivity

The system shall be capable of operating in a non line of sight environment. The manufacturer shall specify the equipment capacity and sensitivity under multipath conditions with delay spread ranging from 0 to 20 μ s.

5.7.5 CW interference

For a receiver operating at the RSL specified in relevant part for 10^{-6} BER threshold, the introduction of a CW interferer at a level of +30 dB, with respect to the wanted signal and at any frequency up to 2 GHz, excluding frequencies either side of the centre frequency of the RF-channel till up to 450 % the co-polar channel spacing, shall not cause a degradation of more than 1 dB of the BER threshold.

This test is designed to identify specific frequencies at which the receiver may have a spurious response, e.g: image frequency, harmonics of the receive filter, etc. The actual test range should be adjusted accordingly. The test is not intended to imply a relaxed specification at all out of band frequencies elsewhere specified in the present document.

5.7.6 Two tone interference

For a receiver operating at the RSL specified in the relevant part for a 10^{-6} BER threshold, the introduction of two signals at frequencies offset from the channel centre frequency by ± 450 % of channel bandwidth and ± 900 % of channel bandwidth respectively and at a level 30 dB above the RSL shall not cause a degradation of more than 1 dB in the receiver BER threshold.

5.7.7 Impulsive interference

For P-MP equipment operating in the frequency range 0,3 GHz to 1,0 GHz, the receiver BER shall be measured in the presence of wide band impulsive noise at a quasi-peak level of -102 dBm, measured in a 120 kHz bandwidth. The impulses are assumed to be periodic with a repetition rate between 10 Hz and 1 000 Hz. The noise spectrum shall cover all the channel(s) on which the receiver is operating.

The manufacturer shall declare the degradation of receiver sensitivity corresponding to a BER = 10^{-3} and 10^{-6} caused by the impulsive noise conditions defined above.

6 Types of interfaces at the subscriber equipment and the network exchange

Table 2 lists a range of interfaces for various voice and data services. At least one of these interfaces shall be implemented in a Point-to-Multipoint (P-MP) system covered by the present document.

Table 2: Types of interfaces / ranges

Interface	Proposed standards
User equipment interfaces	
Analogue (2 wires)	ITU-T Recommendation Q.552 [31] / EG 201 188 [23]
Analogue (4 W + E & M)	ITU-T Recommendation Q.553 [32]
Digital data port	ITU-T Recommendation G.703 [6], H, X and V series
ISDN basic rate S Interface	ETS 300 012 [10]
ISDN basic rate U interface	ITU-T Recommendation G.961 [7]
CSMA/CD Ethernet interface	ISO/IEC 8802-3 [21]
Network interfaces	
2 Mbit/s	ITU-T Recommendation G.703 [6]
Analogue (2 wires)	ITU-T Recommendation Q.552 [31]
Analogue (4 W + E & M)	ITU-T Recommendation Q.553 [32]
Digital data port	ITU-T Recommendation G.703 [6], H,X and V Series
ISDN basic rate S-interface	ETS 300 012 [10]
ISDN + Analogue subscribers + Leased lines 2 Mbit/s Interface	ITU-T Recommendation G.964 [8] V5-1 ITU-T Recommendation G.965 [9] V5-2 EN 300 324 [11] EN 300 347 [12]
ISDN U interface	ITU-T Recommendation G.961 [7]
CSMA/CD Ethernet interface	ISO/IEC 8802-3 [21]

Annex A (informative): Impulsive interference

The test level for man-made noise is derived from the specification for vehicle emissions included in European Directive 95/54/EC [29]. This represents the noise source in rural areas with low vehicle traffic conditions and is also consistent with a number of measurements made in the 0,3 GHz to 1 GHz band (i.e. COST 207). The specification level is -112 dBm, quasi-peak, measured in a 120 kHz bandwidth, and exhibits a -20dB per decade frequency dependence. Other sources of man-made noise are generally at a much lower level (see ITU-R Recommendation 372-6 [38]). In order to account the worst case scenario whereby the noise arrives on bore-sight of the antenna connected to the equipment, a term is added to account for antenna gain. Because antenna gain is not part of the equipment specification, it is accounted for by using a general term rather than a variable attribute of different antennas. In the frequency range of interest, antenna gain is limited by size (and cost) constraints to a maximum value of around 10 dB at 1 GHz, including feed losses. This increases the noise specification level to -102 dBm at 1 GHz.

For a given physical antenna size, standard antenna theory shows that antenna gain is inversely proportional to the square of the wavelength. It therefore exhibits a +20 dB per decade frequency dependence, and this is followed fairly closely in practical designs within the 0,3 GHz to 1 GHz frequency range. As the frequency dependence of the antenna gain and quasi-peak power are in opposite directions they cancel, removing frequency dependant terms from the present document.

Bibliography

The following material, though not specifically referenced in the body of the present document (or not publicly available), gives supporting information.

ITU-T Recommendation G.704: "Synchronous frame structures used at 1 544, 6 312, 2 048, 8 448 and 44 736 kbit/s hierarchical levels".

CCITT Recommendation I.412: "ISDN user-network interfaces - Interface structures and access capabilities".

ITU-T Recommendation O.151: "Error performance measuring equipment operating at the primary rate and above".

ETSI TR 101 036-1: "Fixed Radio Systems; Point-to-point equipment; Generic wordings for standards on digital radio systems characteristics; Part 1: General aspects and point-to-point equipment parameters".

ITU-T Recommendation G.712: "Transmission performance characteristics of pulse code modulation channels"

NOTE: Replaces G.712, G.713, G.714, G.715.

ETSI EN 301 390: "Fixed Radio Systems; Point-to-point and Point-to-Multipoint Systems; Spurious emissions and receiver immunity at equipment/antenna port of Digital Fixed Radio Systems".

CCITT Recommendation R.20: "Telegraph modem for subscriber lines".

ITU-T Recommendation G.826: "Error performance parameters and objectives for international, constant bit rate digital paths at or above the primary rate".

ITU-R Recommendation F.1189-1: "Error performance objectives for constant bit rate digital paths at or above the primary rate carried by digital radio-relay systems which may form part or all of the national portion of a 27 500 km hypothetical reference path".

ITU-T Recommendation O.181: "Equipment to assess error performance on STM-N interfaces".

IEC CISPR 16-1 (1993): "Specification for radio disturbance and immunity measuring apparatus and methods - Part 1: Radio disturbance and immunity measuring apparatus".

ETSI ETS 300 386-1: "Equipment Engineering (EE); Telecommunication network equipment; Electro-Magnetic Compatibility (EMC) requirements; Part 1: Product family overview, compliance criteria and test levels".

History

Document history			
V1.1.1	January 2000	Public Enquiry	PE 200021: 2000-01-26 to 2000-05-26
V1.1.1	August 2000	Vote	V 20001013: 2000-08-14 to 2000-10-13