

Final draft **ETSI EN 301 449** V1.1.1 (2006-05)

Candidate Harmonized European Standard (Telecommunications series)

**Electromagnetic compatibility
and Radio spectrum Matters (ERM);
Harmonized EN for CDMA spread spectrum base stations
operating in the 450 MHz cellular band (CDMA 450) and
410, 450 and 870 MHz PAMR bands (CDMA-PAMR)
covering essential requirements
of article 3.2 of the R&TTE Directive**



Reference

DEN/ERM-TG39-001

Keywords

base station, CDMA, cellular, radio, regulation

ETSI

650 Route des Lucioles
F-06921 Sophia Antipolis Cedex - FRANCE

Tel.: +33 4 92 94 42 00 Fax: +33 4 93 65 47 16

Siret N° 348 623 562 00017 - NAF 742 C
Association à but non lucratif enregistrée à la
Sous-Préfecture de Grasse (06) N° 7803/88

Important notice

Individual copies of the present document can be downloaded from:

<http://www.etsi.org>

The present document may be made available in more than one electronic version or in print. In any case of existing or perceived difference in contents between such versions, the reference version is the Portable Document Format (PDF). In case of dispute, the reference shall be the printing on ETSI printers of the PDF version kept on a specific network drive within ETSI Secretariat.

Users of the present document should be aware that the document may be subject to revision or change of status. Information on the current status of this and other ETSI documents is available at

<http://portal.etsi.org/tb/status/status.asp>

If you find errors in the present document, please send your comment to one of the following services:

http://portal.etsi.org/chaicor/ETSI_support.asp

Copyright Notification

No part may be reproduced except as authorized by written permission.
The copyright and the foregoing restriction extend to reproduction in all media.

© European Telecommunications Standards Institute 2006.
All rights reserved.

DECT™, PLUGTESTS™ and UMTS™ are Trade Marks of ETSI registered for the benefit of its Members.
TIPHON™ and the TIPHON logo are Trade Marks currently being registered by ETSI for the benefit of its Members.
3GPP™ is a Trade Mark of ETSI registered for the benefit of its Members and of the 3GPP Organizational Partners.

Contents

| | |
|------------------------------------------------------------------------------------|----|
| Intellectual Property Rights | 5 |
| Foreword..... | 5 |
| Introduction | 6 |
| 1 Scope | 8 |
| 2 References | 8 |
| 3 Definitions, symbols and abbreviations | 9 |
| 3.1 Definitions | 9 |
| 3.2 Symbols..... | 12 |
| 3.3 Abbreviations | 12 |
| 4 Technical requirements specifications | 13 |
| 4.1 Environmental profile..... | 13 |
| 4.2 Conformance requirements | 13 |
| 4.2.1 Introduction..... | 13 |
| 4.2.2 Transmitter conducted unwanted emissions | 13 |
| 4.2.2.1 Definition | 14 |
| 4.2.2.2 Limits | 14 |
| 4.2.2.2.1 Limits for band class 5 equipment..... | 14 |
| 4.2.2.2.2 Limits for band class 11 equipment..... | 14 |
| 4.2.2.2.3 Limits for band class 12 equipment..... | 15 |
| 4.2.2.3 Conformance..... | 16 |
| 4.2.3 Accuracy of maximum output power..... | 16 |
| 4.2.3.1 Definition | 16 |
| 4.2.3.2 Limits | 16 |
| 4.2.3.3 Conformance | 17 |
| 4.2.4 Radiated spurious emissions | 17 |
| 4.2.4.1 Definition | 17 |
| 4.2.4.2 Limits | 17 |
| 4.2.4.3 Conformance..... | 18 |
| 4.2.5 Inter-base station transmitter intermodulation | 18 |
| 4.2.5.1 Definition | 18 |
| 4.2.5.2 Limits | 18 |
| 4.2.5.3 Conformance..... | 18 |
| 4.2.6 Receiver conducted spurious emissions..... | 18 |
| 4.2.6.1 Definition | 18 |
| 4.2.6.2 Limits | 19 |
| 4.2.6.3 Conformance..... | 19 |
| 4.2.7 Single tone desensitization..... | 19 |
| 4.2.7.1 Definition | 19 |
| 4.2.7.2 Limits | 19 |
| 4.2.7.3 Conformance..... | 19 |
| 5 Testing for compliance with technical requirements..... | 19 |
| 5.1 Conditions for testing | 19 |
| 5.1.1 Introduction..... | 19 |
| 5.1.2 Standard equipment under test..... | 20 |
| 5.1.2.1 Basic equipment | 20 |
| 5.1.2.2 Ancillary equipment..... | 20 |
| 5.2 Interpretation of the measurement results | 20 |
| 5.3 Essential radio test suites..... | 21 |
| 5.3.1 Transmitter conducted unwanted emissions | 21 |
| 5.3.1.1 Test procedure..... | 21 |
| 5.3.2 Accuracy of maximum output power..... | 22 |
| 5.3.2.1 Test procedure for base stations supporting operation in 1X systems..... | 23 |
| 5.3.2.2 Test procedure for base stations supporting operation in HRPD systems..... | 23 |

| | | |
|-------------------------------|------------------------------------------------------------------------------------|-----------|
| 5.3.3 | Radiated spurious emissions | 23 |
| 5.3.3.1 | Test method..... | 23 |
| 5.3.3.2 | Test configurations..... | 24 |
| 5.3.4 | Inter-base station transmitter intermodulation | 24 |
| 5.3.4.1 | Test procedure for base stations supporting operation in 1X systems..... | 24 |
| 5.3.4.2 | Test procedure for base stations supporting operation in HRPD systems 2..... | 25 |
| 5.3.5 | Receiver conducted spurious emissions..... | 26 |
| 5.3.5.1 | Test procedure for base stations supporting operation in 1X or HRPD systems..... | 26 |
| 5.3.6 | Single tone desensitization..... | 26 |
| 5.3.6.1 | Test procedure..... | 26 |
| Annex A (normative): | The HS Requirements and conformance Test specifications Table (HS-RTT)..... | 28 |
| Annex B (normative): | Base station configurations | 31 |
| B.1 | Receiver diversity..... | 31 |
| B.2 | Duplexers | 31 |
| B.3 | Power supply options | 31 |
| B.4 | Ancillary RF amplifiers..... | 32 |
| B.5 | BS using antenna arrays | 32 |
| B.5.1 | Receiver tests..... | 33 |
| B.5.2 | Transmitter tests | 33 |
| Annex C (normative): | Environmental profile specification | 34 |
| C.1 | Test conditions, power supply and ambient temperatures..... | 34 |
| C.1.1 | Normal and extreme test conditions | 34 |
| C.1.2 | Power sources..... | 34 |
| C.1.2.1 | Power sources for stand-alone equipment | 34 |
| C.1.3 | Normal test conditions..... | 34 |
| C.1.3.1 | Normal temperature and humidity | 34 |
| C.1.3.2 | Normal power source..... | 35 |
| C.1.3.2.1 | Mains voltage | 35 |
| C.1.3.2.2 | Lead-acid battery power sources used on vehicles..... | 35 |
| C.1.3.2.3 | Other power sources..... | 35 |
| C.1.4 | Extreme test conditions | 35 |
| C.1.4.1 | Extreme temperatures | 35 |
| C.1.4.2 | Extreme power source voltages | 35 |
| C.1.4.2.1 | Mains voltage | 35 |
| C.1.4.2.2 | Power sources using other types of batteries..... | 36 |
| C.1.4.2.3 | Other power sources..... | 36 |
| C.1.4.3 | Procedure for tests at extreme temperatures | 36 |
| C.2 | Declared environmental operating conditions of equipment..... | 36 |
| Annex D (informative): | Bibliography | 37 |
| Annex E (informative): | The EN title in the official languages | 38 |
| History | | 40 |

Intellectual Property Rights

IPRs essential or potentially essential to the present document may have been declared to ETSI. The information pertaining to these essential IPRs, if any, is publicly available for **ETSI members and non-members**, and can be found in ETSI SR 000 314: "*Intellectual Property Rights (IPRs); Essential, or potentially Essential, IPRs notified to ETSI in respect of ETSI standards*", which is available from the ETSI Secretariat. Latest updates are available on the ETSI Web server (<http://webapp.etsi.org/IPR/home.asp>).

Pursuant to the ETSI IPR Policy, no investigation, including IPR searches, has been carried out by ETSI. No guarantee can be given as to the existence of other IPRs not referenced in ETSI SR 000 314 (or the updates on the ETSI Web server) which are, or may be, or may become, essential to the present document.

Foreword

This Candidate Harmonized European Standard (Telecommunications series) has been produced by ETSI Technical Committee Electromagnetic compatibility and Radio spectrum Matters (ERM), and is now submitted for the Vote phase of the ETSI standards Two-step Approval Procedure.

The present document has been produced by ETSI in response to a mandate from the European Commission issued under Council Directive 98/34/EC (as amended) laying down a procedure for the provision of information in the field of technical standards and regulations.

The present document is intended to become a Harmonized Standard, the reference of which will be published in the Official Journal of the European Communities referencing the Directive 1999/5/EC [1] of the European Parliament and of the Council of 9 March 1999 on radio equipment and telecommunications terminal equipment and the mutual recognition of their conformity ("the R&TTE Directive") [1].

Technical specifications relevant to Directive 1999/5/EC [1] are given in annex A.

| Proposed national transposition dates | |
|----------------------------------------------------------------------------------------|---------------------------------|
| Date of latest announcement of this EN (doa): | 3 months after ETSI publication |
| Date of latest publication of new National Standard or endorsement of this EN (dop/e): | 6 months after doa |
| Date of withdrawal of any conflicting National Standard (dow): | 18 months after doa |

Introduction

The present document is part of a set of standards designed to fit in a modular structure to cover all radio and telecommunications terminal equipment under the R&TTE Directive [1]. Each standard is a module in the structure. The modular structure is shown in figure 1.

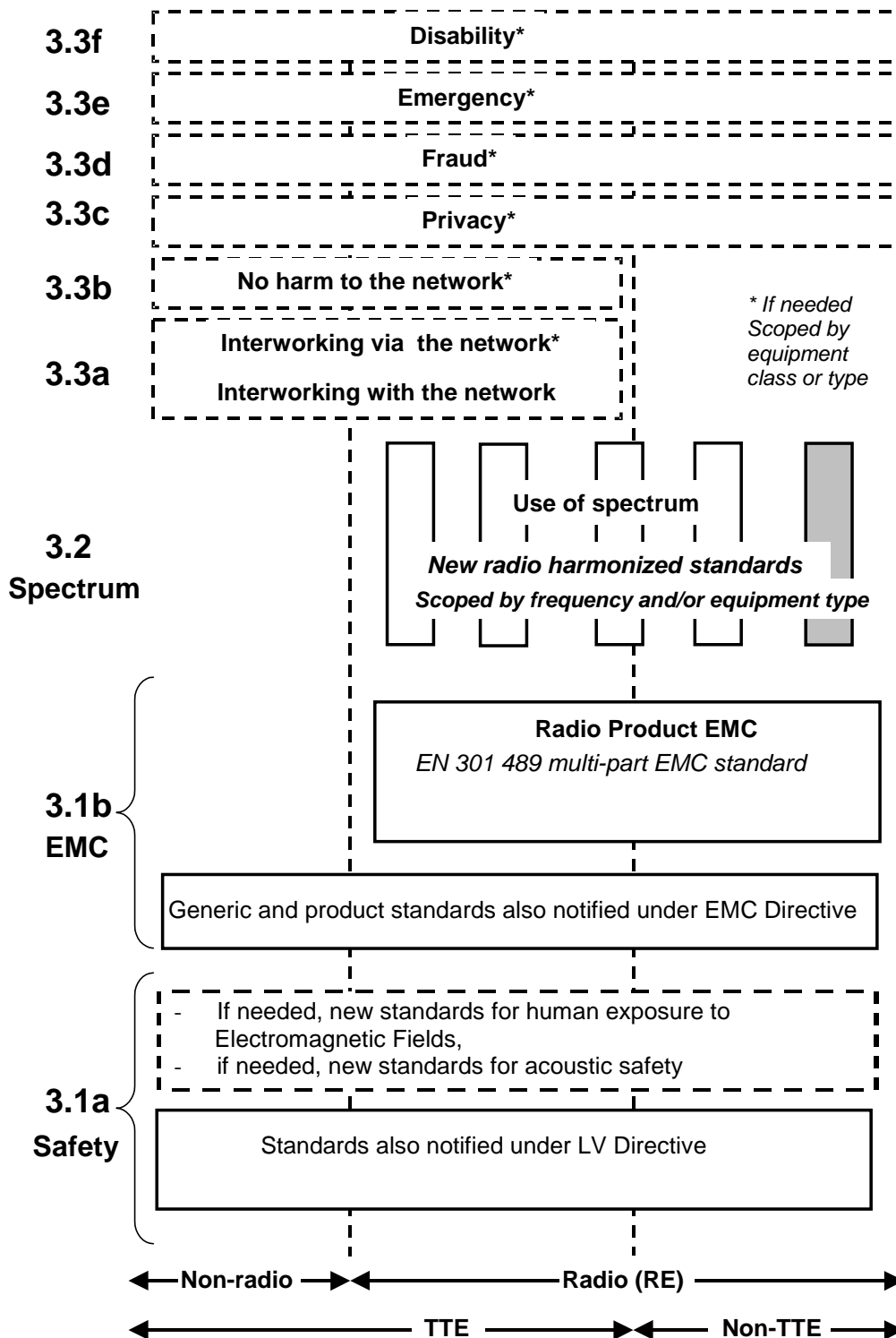

Figure 1: Modular structure for the various standards used under the R&TTE Directive [1]

The left hand edge of figure 1 shows the different clauses of article 3 of the R&TTE Directive [1].

For article 3.3 various horizontal boxes are shown. Dotted lines indicate that at the time of publication of the present document essential requirements in these areas have to be adopted by the Commission. If such essential requirements are adopted, and as far and as long as they are applicable, they will justify individual standards whose scope is likely to be specified by function or interface type.

The vertical boxes show the standards under article 3.2 for the use of the radio spectrum by radio equipment. The scopes of these standards are specified either by frequency (normally in the case where frequency bands are harmonized) or by radio equipment type.

For article 3.1b, figure 1 shows EN 301 489 [6], the multi-part product EMC standard for radio used under the EMC Directive [2].

For article 3.1a, figure 1 shows the existing safety standards currently used under the LV Directive [3] and new standards covering human exposure to electromagnetic fields. New standards covering acoustic safety may also be required.

The bottom of figure 1 shows the relationship of the standards to radio equipment and telecommunications terminal equipment. A particular equipment may be radio equipment, telecommunications terminal equipment or both. A radio spectrum standard will apply if it is radio equipment. An article 3.3 standard will apply as well only if the relevant essential requirement under the R&TTE Directive [1] is adopted by the Commission and if the equipment in question is covered by the scope of the corresponding standard. Thus, depending on the nature of the equipment, the essential requirements under the R&TTE Directive [1] may be covered in a set of standards.

The modularity principle has been taken because:

- It minimizes the number of standards needed. Because equipment may, in fact, have multiple interfaces and functions it is not practicable to produce a single standard for each possible combination of functions that may occur in an equipment.
- It provides scope for standards to be added:
 - under article 3.2, when new frequency bands are agreed; or
 - under article 3.3, should the Commission take the necessary decisions;without requiring alteration of standards that are already published.
- It clarifies, simplifies and promotes the usage of Harmonized Standards as the relevant means of conformity assessment.

The product specifications upon which the present document is based differ in presentation, and this is reflected in the present document.

1 Scope

The present document applies to cdma450 base stations using CDMA 1x spread spectrum technology, i.e. Band Class 5 or Band Class 11 equipment capable of operating in the frequency bands defined in footnote EU34 from the European Common Allocation table, ERC report 25 [10].

- EU34 states "Parts of the bands 450 MHz to 457,5 MHz / 460 MHz to 467,5 MHz may also be used for existing and evolving public cellular networks on a National basis".

The present document also applies to CDMA-PAMR base stations covering, in accordance with ECC decision ECC/DEC/(04)06 [11], the frequency bands:

- Band Class 11: Operating within the bands 410 MHz to 430 MHz and 450 MHz to 470 MHz with 10 MHz duplex spacing between the transmit frequencies of mobile stations (410 MHz to 420 MHz and 450 MHz to 460 MHz) and the transmit frequencies of base stations (420 MHz to 430 MHz and 460 MHz to 470 MHz).
- Band Class 12: Operating within the band 870 MHz to 876 MHz paired with 915 MHz to 921 MHz with 45 MHz duplex spacing between the transmit frequencies of mobile stations (870 MHz to 876 MHz) and the transmit frequencies of base stations (915 MHz to 921 MHz).

The present document is intended to cover the provisions of Directive 1999/5/EC (R&TTE Directive) [1] article 3.2, which states that "radio equipment shall be so constructed that it effectively uses the spectrum allocated to terrestrial/space radio communications and orbital resources so as to avoid harmful interference".

In addition to the present document, other ENs that specify technical requirements in respect of essential requirements under other parts of article 3 of the R&TTE Directive [1] will apply to equipment within the scope of the present document.

NOTE: A list of such ENs is included on the web site <http://www.newapproach.org/>.

2 References

The following documents contain provisions which, through reference in this text, constitute provisions of the present document.

- References are either specific (identified by date of publication and/or edition number or version number) or non-specific.
- For a specific reference, subsequent revisions do not apply.
- For a non-specific reference, the latest version applies.

Referenced documents which are not found to be publicly available in the expected location might be found at <http://docbox.etsi.org/Reference>.

- [1] Directive 1999/5/EC of the European Parliament and of the Council of 9 March 1999 on radio equipment and telecommunications terminal equipment and the mutual recognition of their conformity (R&TTE Directive).
- [2] Council Directive 89/336/EEC of 3 May 1989 on the approximation of the laws of the Member States relating to electromagnetic compatibility (EMC Directive).
- [3] Council Directive 73/23/EEC of 19 February 1973 on the harmonization of the laws of Member States relating to electrical equipment designed for use within certain voltage limits (LV Directive).
- [4] ANSI/TIA-97-F (2005): "Recommended Minimum Performance Standards for cdma2000® Spread Spectrum Base Stations".
- [5] TIA/EIA/IS-2000.2-B (2002): "Physical Layer Standard for cdma2000® Spread Spectrum Systems - Release B".

- [6] ETSI EN 301 489 (all parts): "Electromagnetic compatibility and Radio spectrum Matters (ERM); ElectroMagnetic Compatibility (EMC) standard for radio equipment and services".
- [7] TIA-864 (2003): "Recommended Minimum Performance Standards for cdma2000® High Rate Packet Data Access Network Equipment".
- [8] TIA/EIA/IS-890 (2001): "Test Application Specification (TAS) for High Rate Packet Data Air Interface".
- [9] ITU-R Recommendation SM.329-10 (2003): "Unwanted emissions in the spurious domain".
- [10] ERC Report 25, Copenhagen 2004: "The European table of frequency allocations and utilisations covering the frequency range 9 kHz to 275 GHz".
- [11] ECC/DEC/(04)06: "ECC Decision of 19 March 2004 on the availability of frequency bands for the introduction of Wide Band Digital Land Mobile PMR/PAMR in the 400 MHz and 800/900 MHz bands".
- [12] ECC Report 39, Granada February 2004: "Technical impact of introducing CDMA-PAMR on 12.5/25 kHz PMR/PAMR technologies in the 410-430 and 450-470 MHz bands".
- [13] ECC Report 41, Granada February 2004: "Adjacent band compatibility between GSM and CDMA-PAMR at 915 MHz".
- [14] ETSI TR 100 028 (V1.4.1): "ElectroMagnetic Compatibility and Radio Spectrum Matters (ERM); Uncertainties in the measurement of mobile radio equipment characteristics".
- [15] CEPT/ERC/REC 74-01E, Hradec Kralove 2005: "Unwanted emissions in the spurious domain".
- [16] TIA 1030 (2004)"Band Class Specification for cdma2000® Spread Spectrum Systems ".

3 Definitions, symbols and abbreviations

3.1 Definitions

For the purposes of the present document, the terms and definitions given in the R&TTE Directive [1] and the following apply:

1X: mode of operation of a base station or access network using spreading rate 1

access network: network equipment providing data connectivity between a packet switched data network (typically the Internet) and the access terminals in HRPD systems

NOTE: Connectivity is typically provided at the link layer (PPP). As used in the present document it is synonymous with base station except that HRPD access network always use spreading rate 1.

access terminal: mobile station providing data connectivity to a user in HRPD systems

NOTE: An access terminal may be connected to a computing device such as a laptop personal computer or may be a self-contained data device such as a personal digital assistant or may be a mobile station. Also referred to as HRPD access terminal using spreading rate 1 or a mobile station operating in a HRPD system.

band class: set of frequency channels, transmission mask and a numbering scheme for these channels

NOTE: Band classes are defined in TIA 1030 [16], clause 3.1.

base station: fixed station used for communicating with mobile stations

NOTE: Depending upon the context, the term base station may refer to a cell, a sector within a cell, an MSC, and access network or other part of the wireless system.

CDMA channel number: 11-bit number corresponding to the centre of the CDMA frequency assignment

CDMA frequency assignment: 1,23 MHz segment of spectrum

NOTE: For band classes 11 and 12, the channel is centred on one of the 25 kHz channels.
For band class 5, the channel is centred on one of the 20 kHz or 25 kHz channels.

code channel: subchannel of a forward CDMA channel or reverse CDMA channel

NOTE: Each subchannel uses an orthogonal Walsh function or quasi-orthogonal function

Code Division Multiple Access (CDMA): technique for spread-spectrum multiple-access digital communications that creates channels through the use of unique code sequences

DRCLock Channel: portion of the Forward MAC Channel that indicates to the access terminal whether the access network can decode the DRC sent by the access terminal or not

NOTE: The DRCLock Channel and the RPC Channel are time-division multiplexed and transmitted on the same MAC Channel.

effective radiated power: product of the power supplied to the antenna and the antenna gain in a direction relative to a half-wave dipole

enclosure port: also known as cabinet radiation

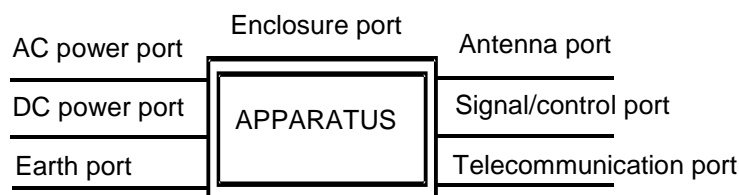

forward CDMA channel: CDMA channel from a base station to mobile stations

NOTE: The forward CDMA channel contains one or more code channels that are transmitted on a CDMA frequency assignment using a particular pilot PN offset.

forward MAC channel: forward channel used for medium access control in HRPD systems

NOTE: Forward MAC channel consists of the reverse power control channels, the DRCLock channel and the reverse activity channel.

forward traffic channel: one or more code channels used to transport user and signalling traffic from the base station to the mobile station

Frame Error Rate (FER): Frame Error Rate of forward traffic channel

NOTE: The value of Frame Error Rate may be estimated by using Service Option 2, 9, 32, 54, or 55 (see ANSI/TIA-97-F [4], clause 1.3).

handoff: act of transferring communication with a mobile station from one base station to another

High Rate Packet Data (HRPD): CDMA technique optimized for data communications

MAC channel: See forward MAC channel.

mean output power: total transmitted calorimetric power measured in a specified bandwidth at the antenna connector when the transmitter is active

mobile station: station intended to be used while in motion or during halts at unspecified points

NOTE: Mobile stations include portable units (e.g. hand-held personal units) and units installed in vehicles and HRPD access terminals.

mobile station simulator: piece of test equipment used to replicate the functions of a mobile station

multiple carrier: system set to operate with 2 or more contiguous carriers

packet: physical layer protocol data unit

packet error: packet error event occurs when a decoded packet's FCS does not check

physical layer: part of the communication protocol between the mobile station and the base station that is responsible for the transmission and reception of data

NOTE: The physical layer in the transmitting station is presented a frame and transforms it into an over-the-air waveform. The physical layer in the receiving station transforms the waveform back into a frame.

pilot channel: unmodulated, direct-sequence spread spectrum signal transmitted by a CDMA base station or mobile station

NOTE: A pilot channel provides a phase reference for coherent demodulation and may provide a means for signal strength comparisons between base stations for determining when to handoff.

Provider: the entity responsible for placing the equipment on the market

radio configuration: set of forward traffic channel and reverse traffic channel transmission formats that are characterized by physical layer parameters such as transmission rates, modulation characteristics, and spreading rate

NOTE: Radio configurations are defined in TIA/EIA/IS-2000.2-B [5], clauses 2.1.3 and 3.1.3.

representative configuration: the equipment is set up in a manner which is typical for normal operation, where practical

reverse CDMA channel: CDMA channel from the mobile station to the base station

NOTE: From the base station's perspective, the reverse CDMA channel is the sum of all mobile station transmissions on a CDMA frequency assignment.

reverse test application protocol: test application protocol allowing reverse link performance characterizations in HRPD systems

NOTE: See TIA/EIA/IS-890 [8].

RF carrier: direct-sequence spread RF channel

NOTE: For the forward CDMA channel, the number of RF carriers is equal to the spreading rate; for the reverse CDMA channel, there is one RF carrier.

slot: duration of time specified by 1,6 ms

spreading rate: PN chip rate of the forward CDMA channel or the reverse CDMA channel, defined as a multiple of 1,2288 Mcps

spreading rate 1: spreading rate 1 forward CDMA channel uses a single direct-sequence spread carrier with a chip rate of 1,2288 Mcps, and a spreading rate 1 reverse CDMA channel uses a single direct-sequence spread carrier with a chip rate of 1,2288 Mcps

NOTE: Spreading rate 1 is often referred to as "1X".

spurious emissions: as defined by ITU-R Recommendation SM.329-10 [9]

traffic channel: communication path between a mobile station and a base station used for user and signalling traffic

NOTE: The term traffic channel implies a forward traffic channel and reverse traffic channel pair. See also forward traffic channel and reverse traffic channel.

Walsh function: one of 2^N time orthogonal binary functions

NOTE: The functions are orthogonal after mapping "0" to 1 and "1" to -1.

3.2 Symbols

For the purposes of the present document, the following symbols apply:

| | |
|------|-------------------------------------------------------------------------------------------------------------------------------------------------------------------------------------------------------------------------------------------------------------------------------------------------------------------------------------------------------------------------|
| dBc | Ratio (in dB) of the sideband power of a signal, measured in a given bandwidth at a given frequency offset from the centre frequency of the same signal, to the total inband power of the signal. For CDMA, the total inband power of the signal is measured in a 1,23 MHz bandwidth around the centre frequency of the CDMA signal for a spreading rate 1 CDMA signal. |
| dBm | Measure of power expressed in terms of its ratio (in dB) to 1 mW |
| Fc | Nominal centre frequency |
| Mcps | Megachips per second (10 ⁶ chips per second) |
| Pout | Transmitter Output Power |

3.3 Abbreviations

For the purposes of the present document, the following abbreviations apply:

| | |
|----------|-------------------------------------------------------------|
| AWGN | Additive White Gaussian Noise |
| BS | Base Station |
| CDMA | Code Division Multiple Access |
| CW | Continuous Waveform |
| DC | Direct Current |
| DRC | Data Rate Control |
| e.i.r.p. | equivalent isotropically radiated power |
| e.r.p. | effective radiated power |
| EMC | ElectroMagnetic Compatibility |
| EUT | Equipment Under Test |
| FCS | Frame Check Sequence |
| FER | Frame Error Rate |
| FTAP | Forward Test Application Protocol |
| GSM | Global System for Mobile |
| HRPD | High Rate Packet Data |
| HS-RTT | HS - Requirements and conformance Test specifications Table |
| LV | Low Voltage |
| MAC | Medium Access Control |
| MSC | Mobile Switching Centre |
| PAMR | Public Access Mobile Radio |
| PER | Packet Error Rate |

NOTE: $PER = 1 - \frac{\text{Number of good packets received}}{\text{Number of packets transmitted}}$

| | |
|-------|-------------------------------------------------|
| PN | PseudoNoise |
| PPP | Point to Point Protocol |
| R&TTE | Radio and Telecommunications Terminal Equipment |
| RA | Reverse Activity |
| RC | Reverse Channel |
| RF | Radio Frequency |
| RF/IF | Radio Frequency/Intermediate Frequency |
| RMS | Root Mean Square |
| RPC | Reverse Power Control |
| RTAP | Reverse Test Application Protocol |
| Rx | Receiver |
| Tx | Transmitter |

4 Technical requirements specifications

4.1 Environmental profile

The technical requirements of the present document apply under the environmental profile for operation of the equipment, which shall be determined by the environmental class of the equipment as declared by the provider. The equipment shall comply with all the technical requirements of the present document at all times when operating within the boundary limits of the declared operational environmental profile.

For guidance on how a provider can declare the environmental profile see annex C of the present document.

4.2 Conformance requirements

4.2.1 Introduction

To satisfy the essential requirement under article 3.2 of the R&TTE Directive [1] for Base Stations (BS) the following essential parameters have been identified. Table 1 provides a cross-reference between these essential parameters and the corresponding technical requirements for equipment within the scope of the present document.

The equipment shall be in compliance with all the technical requirements in table 1 for each of the corresponding essential parameters in order to fulfil the essential requirement.

Table 1: Cross references

| Essential parameter | Corresponding technical requirements |
|-----------------------------------------------------------------------------------------------------------------------------------------------------------------------------------------------------------------------------------------------------------------------------------------|-------------------------------------------------------|
| Spectrum emissions mask | 4.2.2 Transmitter conducted unwanted emissions |
| Conducted spurious emissions from the transmitter antenna connector | 4.2.2 Transmitter conducted unwanted emissions |
| Accuracy of maximum output power | 4.2.3 Accuracy of maximum output power |
| Radiated emissions | 4.2.4 Radiated spurious emissions |
| Intermodulation attenuation of the transmitter | 4.2.5 Inter-base station transmitter intermodulation |
| Conducted spurious emissions from the receiver antenna connector | 4.2.6 Receiver conducted spurious emissions |
| Impact of interference on receiver performance | 4.2.7 Single Tone Desensitisation (Receiver blocking) |
| NOTE: The frequency accuracy is covered under spectrum emission mask because this is defined with reference to the nominal centre frequency. If there is any frequency error, the same emissions mask must be met, so the error does not give rise to any higher level of interference. | |

The manufacturer or person responsible for placing the equipment on the market shall declare the operating band class(es) of the equipment. The operating band class(es) shall be recorded in the documentation. The applicable set of technical requirements for each band class is defined in the HS-RTT in annex A.

4.2.2 Transmitter conducted unwanted emissions

NOTE: Attention is drawn to the conclusions of ECC reports 39 [12] and 41 [13] describing additional mitigation techniques in situations where CDMA-PAMR base stations are in close proximity to PMR/PAMR or GSM base stations which operate in adjacent frequency allocations.

4.2.2.1 Definition

Transmitter conducted unwanted emissions are emissions at frequencies that are outside the assigned channel, measured at the base station RF output port.

For HRPD Channels, transmitter conducted unwanted emissions are measured for two test conditions:

- Case 1: continuous data mode (no idle slots).
- Case 2: idle mode (all idle slots, except the control channel).

NOTE: Inhibiting the control channel is optional for case 2.

4.2.2.2 Limits

4.2.2.2.1 Limits for band class 5 equipment

The level of the transmitter conducted unwanted emission(s) measured within the appropriate bandwidth shall not exceed the limits specified in table 2. The limits in table 2 shall not be exceeded when transmitting on a single or all RF carriers supported by the base station and configured in accordance with the manufacturer's specification.

Table 2: Transmitter conducted unwanted emission limits for Band Class 5

| For $ \Delta f $ within the range | Applicability | Emission Limit | |
|-----------------------------------------------------------------------------------------------------------------------------------------------------------------------------------------------------------------------------------------------------------------------------------------------|-----------------------------|---------------------------------------------------------------------------------------------------------------------------------------|-------------------------------------------------------------------------------------------|
| 750 kHz to 1,98 MHz | Single carrier | -45 dBc / 30 kHz | |
| 1,98 MHz to 4,00 MHz | Single carrier | -60 dBc / 30 kHz; $P_{out} \geq 33$ dBm -27 dBm / 30 kHz; 28 dBm $\leq P_{out} < 33$ dBm -55 dBc / 30 kHz; $P_{out} < 28$ dBm | |
| 4,00 MHz to 6,40 MHz | Single and multiple carrier | -36 dBm / 1 kHz | 30 MHz < f < 1 GHz |
| 6,40 MHz to 16 MHz | Single and multiple carrier | -36 dBm / 10 kHz | 30 MHz < f < 1 GHz |
| > 16 MHz | Single and multiple carrier | -36 dBm / 1 kHz -36 dBm / 10 kHz -36 dBm / 100 kHz -30 dBm / 1 MHz | 9 kHz < f < 150 kHz 150 kHz < f < 30 MHz 30 MHz < f < 1 GHz 1 GHz < f < 12,5 GHz |
| NOTE 1: All frequencies in the measurement bandwidth should satisfy the restrictions on $ \Delta f $ where Δf = centre frequency - closer measurement edge frequency (f). | | | |
| NOTE 2: For multiple-carrier testing, Δf is defined for positive Δf as the centre frequency of the highest carrier - closer measurement edge frequency (f) and for negative Δf as the centre frequency of the lowest carrier - closer measurement edge frequency (f). | | | |

4.2.2.2.2 Limits for band class 11 equipment

The transmitter conducted unwanted emissions shall be less than the limits specified in table 3. The transmitter conducted unwanted emissions limits in table 3 shall be met when transmitting on a single or all RF carriers supported by the base station and configured in accordance with the manufacturer's specification.

Table 3: Transmitter conducted unwanted emission limits for Band Class 11

| For $ \Delta f $ Within the Range | Applicability | Emission Limit | |
|-----------------------------------------------------------------------------------------------------------------------------------------------------------------------------------------------------------------------------------------------------------------------------------------------|-----------------------------|-----------------------------------------------------------------------------|-------------------------------------------------------------------------------------------|
| 750 kHz to 885 kHz | Single carrier | $-45-15(\Delta f -750)/135$ dBc in 30 kHz | |
| 885 kHz to 1 125 kHz | Single carrier | $-60-5(\Delta f -885)/240$ dBc in 30 kHz | |
| 1,125 MHz to 1,98 MHz | Single carrier | -65 dBc / 30 kHz | |
| 1,98 MHz to 4,00 MHz | Single carrier | -75 dBc / 30 kHz | |
| 4,00 MHz to 6,00 MHz | Single and multiple carrier | -36 dBm / 100 kHz | |
| 6,00 MHz to 10,00 MHz | Single and multiple carrier | -45 dBm / 100 kHz | |
| > 10,00 MHz | Single and multiple carrier | -36 dBm / 1 kHz -36 dBm / 10 kHz -36 dBm / 100 kHz -30 dBm / 1 MHz | 9 kHz < f < 150 kHz 150 kHz < f < 30 MHz 30 MHz < f < 1 GHz 1 GHz < f < 12,5 GHz |
| NOTE 1: All frequencies in the measurement bandwidth should satisfy the restrictions on $ \Delta f $ where Δf = centre frequency - closer measurement edge frequency (f). | | | |
| NOTE 2: For multiple-carrier testing, Δf is defined for positive Δf as the centre frequency of the highest carrier - closer measurement edge frequency (f) and for negative Δf as the centre frequency of the lowest carrier - closer measurement edge frequency (f). | | | |
| NOTE 3: Limits >10MHz are aligned with CEPT/ERC/REC 74-01E [15]. | | | |

4.2.2.2.3 Limits for band class 12 equipment

The transmitter conducted unwanted emissions shall be less than the limits specified in tables 4 and 5. The transmitter conducted unwanted emissions limits in tables 4 and 5 shall be met when transmitting on a single or all RF carriers supported by the base station and configured in accordance with the manufacturer's specification.

Table 4: Transmitter conducted unwanted emission limits for Band Class 12

| For $ \Delta f $ Within the Range | Applicability | Emission Limit | |
|-----------------------------------------------------------------------------------------------------------------------------------------------------------------------------------------------------------------------------------------------------------------------------------------------|-----------------------------|-----------------------------------------------------------------------------|-------------------------------------------------------------------------------------------|
| 750 kHz to 885 kHz | Single carrier | $-45-15(\Delta f -750)/135$ dBc in 30 kHz | |
| 885 kHz to 1 125 kHz | Single carrier | $-60-5(\Delta f -885)/240$ dBc in 30 kHz | |
| 1,125 MHz to 1,98 MHz | Single carrier | -65 dBc / 30 kHz | |
| 1,98 MHz to 4,00 MHz | Single carrier | -75 dBc / 30 kHz | |
| 4,00 MHz to 6,00 MHz | Single and multiple carrier | -36 dBm / 100 kHz | |
| 6,00 MHz to 45,00 MHz | Single and multiple carrier | -45 dBm / 100 kHz | |
| > 45,00 MHz | Single and multiple carrier | -36 dBm / 1 kHz -36 dBm / 10 kHz -36 dBm / 100 kHz -30 dBm / 1 MHz | 9 kHz < f < 150 kHz 150 kHz < f < 30 MHz 30 MHz < f < 1 GHz 1 GHz < f < 12,5 GHz |
| NOTE 1: All frequencies in the measurement bandwidth should satisfy the restrictions on $ \Delta f $ where Δf = centre frequency - closer measurement edge frequency (f). | | | |
| NOTE 2: For multiple-carrier testing, Δf is defined for positive Δf as the centre frequency of the highest carrier - closer measurement edge frequency (f) and for negative Δf as the centre frequency of the lowest carrier - closer measurement edge frequency (f). | | | |
| NOTE 3: In the frequency range 876 MHz to 915 MHz the limits of table 5 take precedence. | | | |

Table 5 contains additional requirements for the frequency range from 876 MHz to 915 MHz to protect GSM services in adjacent band.

Table 5: Additional Transmitter conducted unwanted emission limits within the frequency range 876 MHz to 915 MHz for Band Class 12 equipment

| For f within the range $ \Delta f $ Within the Range | Applicability | Emission Limit |
|-----------------------------------------------------------------------------------------------------------------------------------------------------------------------------------------------------------------------------------------------------------------------------------------------|-----------------------------|-------------------|
| 1,98 MHz to 4,00 MHz | Single carrier | -100 dBc / 30 kHz |
| 4,00 MHz to 6,00 MHz | Single and multiple carrier | -61 dBm / 100 kHz |
| > 6,00 MHz | Single and multiple carrier | -61 dBm / 100 kHz |
| NOTE 1: All frequencies in the measurement bandwidth should satisfy the restrictions on $ \Delta f $ where Δf = centre frequency - closer measurement edge frequency (f). | | |
| NOTE 2: For multiple-carrier testing, Δf is defined for positive Δf as the centre frequency of the highest carrier - closer measurement edge frequency (f) and for negative Δf as the centre frequency of the lowest carrier - closer measurement edge frequency (f). | | |

4.2.2.3 Conformance

Conformance tests described in clause 5.3.1 shall be carried out.

4.2.3 Accuracy of maximum output power

4.2.3.1 Definition

The maximum output power is the maximum value of the mean power over any specified time interval, delivered to a load with resistance equal to the nominal load impedance of the transmitter.

The manufacturer or person responsible for placing the equipment on the market shall declare the maximum value of the mean output power for the base station. The maximum value of the mean output power shall be recorded in the documentation.

The accuracy of the maximum output power is the maximum allowable error between the measured value and the declared value of the mean output power, when the transmit time slot are at their maximum power setting.

Within each slot, the Pilot, MAC and Traffic or Traffic control channels are time-division multiplexed. All time-division multiplexed channels shall be transmitted at equal power. This test measures the time response of the mean output power for non-idle slots and the mean power at the RF output port.

4.2.3.2 Limits

The maximum output power shall be within +2 dB and -4 dB of the manufacturer's declared output power for the equipment.

Given an ensemble of non-idle half slots, the time response of the ensemble average shall also be within the limits shown in figure 2.

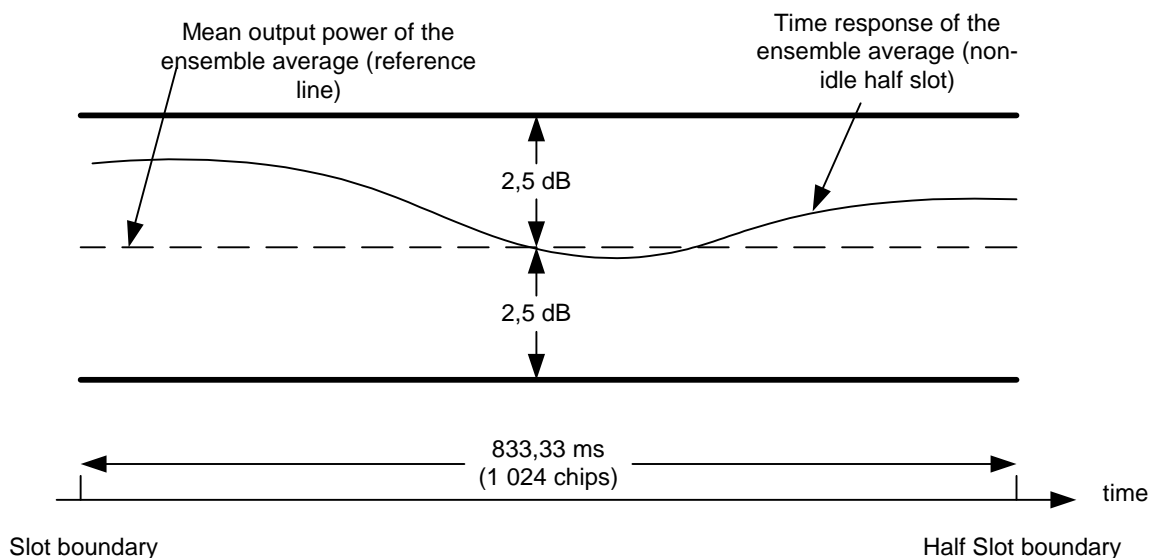

Figure 2: Transmission envelope mask (average non-idle half slot)

4.2.3.3 Conformance

Conformance tests described in clause 5.3.2 shall be carried out.

4.2.4 Radiated spurious emissions

4.2.4.1 Definition

The radiated spurious emissions are the radiated spurious emissions from the enclosure port.

The test for radiated spurious emissions shall be performed on a representative configuration of the equipment under test.

4.2.4.2 Limits

The frequency boundary, reference bandwidths and the limits are based on CEPT/ERC Recommendation 74-01E [15] covering spurious emissions.

The requirements, are shown in table 6.

The base station shall not exceed the limits given in table 6.

Table 6: Radiated unwanted emissions requirements

| Frequency | Maximum e.r.p./ reference bandwidth |
|-------------------------------------------------|----------------------------------------|
| $30 \text{ MHz} \leq f < 1\,000 \text{ MHz}$ | -36 dBm/100 kHz |
| $1 \text{ GHz} \leq f < 12,75 \text{ GHz}$ | -30 dBm/1 MHz |
| $Fc1 - 4 \text{ MHz} < f < Fc2 + 4 \text{ MHz}$ | No requirement |

NOTE 1: Centre frequency of first carrier frequency (Fc1) used by the base station.
 NOTE 2: Centre frequency of last carrier frequency (Fc2) used by the base station.
 NOTE 3: Notes 1 and 2 assume contiguous frequencies otherwise multiple exclusion bands for the occupied bandwidth and out of band emissions will apply.

4.2.4.3 Conformance

Conformance tests described in clause 5.3.3 shall be carried out.

4.2.5 Inter-base station transmitter intermodulation

4.2.5.1 Definition

The ability of the base station to meet the transmitter conducted unwanted emissions limits in the presence of an interfering signal applied to the transmitter port.

Inter-base station transmitter intermodulation (inter-base station and inter-sector are synonymous) occurs when an external signal source is introduced to the antenna connector of the base station. This test verifies that transmitter conducted unwanted emissions are still met with the presence of the interfering source.

Inter-sector transmitter intermodulation is measured for all combinations of idle and non-idle slots in one sector and the other under three test conditions:

- **Case 1** measures the transmitter conducted unwanted emissions level while both sectors are transmitting idle slots.
- **Case 2** measures the transmitter conducted unwanted emissions level while the sector under test are transmitting non-idle slots and the other sector transmitting idle slots.
- **Case 3** measures the transmitter conducted unwanted emissions level while the sector under test are transmitting idle slots and the other sector transmitting non-idle slots.
- **Case 4** measures the transmitter conducted unwanted emissions level while both sectors are transmitting non-idle slots.

4.2.5.2 Limits

The base station shall meet the limits for transmitter conducted unwanted emission requirements in clause 4.2.2.2 of the present document.

4.2.5.3 Conformance

Conformance tests described in clause 5.3.4 shall be carried out.

4.2.6 Receiver conducted spurious emissions

4.2.6.1 Definition

Receiver conducted spurious emissions are spurious emissions generated in the base station equipment and appearing at the receiver RF input ports.

This requirement only applies if the base station is equipped with a separate RF input port.

4.2.6.2 Limits

The receiver conducted spurious emissions shall be:

- 1) Less than -80 dBm, measured in a 30 kHz resolution bandwidth at the base station RF input ports, for frequencies within the base station receiver band as declared by the manufacturer.
- 2) Less than -60 dBm, measured in a 30 kHz resolution bandwidth at the base station RF input ports, for frequencies within the base station transmit band as declared by the manufacturer.
- 3) Less than -57 dBm, measured in a 100 kHz resolution bandwidth at the base station RF input ports, for frequencies from 30 MHz to 1 GHz.
- 4) Less than -47 dBm, measured in a 1 MHz resolution bandwidth at the base station RF input ports, for all other frequencies in the range from 1 GHz to 12,75 GHz.

4.2.6.3 Conformance

Conformance tests described in clause 5.3.5 shall be carried out.

4.2.7 Single tone desensitization

4.2.7.1 Definition

The single tone desensitization is a measure of the base station receiver's ability to receive a wanted signal on the assigned channel frequency in the presence of a continuous wave signal (single tone) that is offset from the centre frequency of the assigned channel.

4.2.7.2 Limits

In the case of adjacent Reverse Channels (RC) supported by the base station, the CW generator frequencies that occur between adjacent carrier centre frequencies should not be tested.

The output power of the mobile station simulator shall increase by no more than 3 dB and the PER measured shall be less than 1,5 % with 95 % confidence (see TIA-864 [7], clause 11.8).

4.2.7.3 Conformance

Conformance tests described in clause 5.3.6 shall be carried out.

5 Testing for compliance with technical requirements

5.1 Conditions for testing

5.1.1 Introduction

Tests defined in the present document shall be carried out at representative points within the boundary limits of the declared operational environmental profile.

Where technical performance varies subject to environmental conditions, tests shall be carried out under a sufficient variety of environmental conditions (within the boundary limits of the declared operational environmental profile) to give confidence of compliance for the affected technical requirements.

All tests shall be conducted using standard test conditions except where otherwise stated (see ANSI/TIA-97-F [4] or TIA-864 [7]). For a definition of standard test conditions and for guidance on the use of other test conditions to be used in order to show compliance reference can be made to annex C.

CDMA-PAMR equipment, due to its different operational receiver conditions may have FER and/or PER settings that are not in line with the test conditions of the present document. However, if the present document is used to assess CDMA-PAMR equipment in the field, the test conditions required by the present document should be used.

5.1.2 Standard equipment under test

5.1.2.1 Basic equipment

The equipment under test shall be assembled and any necessary adjustments shall be made in accordance with the manufacturer's instructions for the mode of operation required. When alternative modes are available, the equipment shall be assembled and adjusted in accordance with the relevant instructions. A complete series of measurements shall be made for each mode of operation.

5.1.2.2 Ancillary equipment

The base station equipment may include ancillary equipment during tests if the ancillary equipment is normally used in the operation of the equipment under test. This would include power supplies, cabinets, antenna couplers, and receiver multi-couplers.

5.2 Interpretation of the measurement results

The interpretation of the results recorded in a test report for the measurements described in the present document shall be as follows:

- the measured value related to the corresponding limit will be used to decide whether an equipment meets the requirements of the present document;
- the value of the measurement uncertainty or the accuracy of each piece of test equipment used for the measurement of each parameter shall be included in the test report; only test equipment meeting the performance requirements for standard test equipment as defined in ANSI/TIA-97-F [4], clause 6.4 or TIA-864 [7], clause 11.4, shall be used;
- the test set-up of each test shall be equivalent to the test set-up descriptions in ANSI/TIA-97-F [4], clause 6.5 or TIA-864 [7], clause 11.5;
- the recorded value of the measurement uncertainty or the recorded value of the accuracy of each piece of test equipment shall be equal to or better than the figures in ANSI/TIA-97-F [4], clause 6.4 or TIA-864 [7], clause 11.4, see tables 7 and 8.

NOTE 1: For convenience in interpreting the present document, some of the more important limits on the acceptable uncertainty of test equipment are reproduced in table 7.

Table 7: Maximum measurement uncertainty

| Equipment used for testing | Uncertainty |
|------------------------------------------------------------|------------------------------------------------------------------------------------------------------|
| Spectrum Analyser Absolute power accuracy | ± 1 dB over the range of -40 dBm to +20 dBm ± 1.3 dB over the range of -70 dBm to +20 dBm |
| CW Generator Absolute output power accuracy | ± 1 dB |
| AWGN Generator Absolute output power accuracy | ± 2 dB |
| Mobile Station Simulator Absolute output power accuracy | ± 0.1 dB |

- For the essential test suites "Maximum output power" and "Radiated spurious emissions" (see clauses 5.3.2 and 5.3.3) the measurement uncertainty figures shall also be calculated in accordance with TR 100 028 [14] and shall correspond to an expansion factor (coverage factor) $k = 1,96$ (which provides a confidence level of 95 % in the case where the distributions characterizing the actual measurement uncertainties are normal (Gaussian)). The calculated values shall be within the values shown in table 8.

Table 8: Maximum measurement uncertainty

| Parameter | Uncertainty for EUT dimension ≤ 1 m | Uncertainty for EUT dimension > 1 m |
|--------------------------------------------------------|-------------------------------------------------------------------------------------------------------------------------------------|---------------------------------------|
| Effective radiated RF power between 30 MHz to 180 MHz | ± 6 dB | ± 6 dB |
| Effective radiated RF power between 180 MHz to 4 GHz | ± 4 dB | ± 6 dB |
| Effective radiated RF power between 4 GHz to 12,75 GHz | ± 6 dB | ± 9 dB (see note) |
| Conducted RF power | ± 1 dB | ± 1 dB |
| NOTE: | This value may be reduced to ± 6 dB when further information on the potential radiation characteristic of the EUT is available. | |

NOTE 2: If the test system for a test is known to have a measurement uncertainty greater than that specified in table 7 or 8, this equipment can still be used, provided that an adjustment is made follows:

- Any additional uncertainty in the test system over and above that specified in the table is used to tighten the test requirements - making the test harder to pass (for some tests, e. g. receiver tests, this may require modification of stimulus signals). This procedure will ensure that a test system not compliant with table 7 or 8 does not increase the probability of passing an EUT that would otherwise have failed a test.

5.3 Essential radio test suites

5.3.1 Transmitter conducted unwanted emissions

For single carrier systems the following test procedure shall be repeated at the:

- highest and lowest carrier frequency as declared by the manufacturer; and
- the carrier frequency as declared by the manufacturer which has the smallest positive offset from the median of these extreme carrier frequencies.

For multiple carrier systems the following test procedure shall be performed with the system set to operate on the maximum number of contiguous carriers using the highest and lowest group of carrier frequencies as declared by the manufacturer.

5.3.1.1 Test procedure

Refer to TIA-864 [7], figure 11.5.1-1 for a functional block diagram of the test set-up.

- Connect the sector under test and an access terminal simulator as shown in TIA-864 [7], figure 11.5.1-1. The AWGN generators are not applicable in this test.
- Connect a spectrum analyser (or other suitable test equipment) to the sector RF output port, using an attenuator or directional coupler if necessary.
- Configure the sector to operate in the band class under assessment and perform steps 4) through 13).

Case 1 (Continuous Data Mode):

- 4) Configure the sector to transmit continuous non-idle slots: Set up a test application session. Open a connection and configure the test application FTAP so that the forward traffic channel data rate correspond to 2 457,6 kbit/s. Configure the MAC Channel with 14 active MAC indices, i.e. the RA Channel and 13 RPC Channels.
- 5) The carrier power shall be adjusted to the maximum level as specified by the manufacturer.
- 6) Measure the average carrier power. Record the value for use in case 2.
- 7) Measure the transmitter conducted unwanted emission levels using appropriate resolution bandwidths consistent with the limits given in clause 4.2.2.2.1 for equipment operating in band class 5, clause 4.2.2.2.2 for equipment operating in band class 11 and clause 4.2.2.2.3 for equipment operating in band class 12. Averaging of up to 25 sweeps may be used.

Case 2 (Idle Mode):

- 8) Configure the sector to transmit a continuous stream of idle slots, except for the control channel, which may either be transmitted or inhibited. Configure 14 active MAC indices on the MAC Channel, i.e. the RA Channel and 13 RPC Channels. Set idle-mode gain to the minimum value specified by the manufacturer.
- 9) Set up the measurement equipment so that the following time windows are measured: The active measurement shall be during a window that starts and stops between 5 and 15 μ s before and after the MAC and pilot channel transmissions.
- 10) Measure the average carrier power of gated transmission during these MAC-Pilot-MAC windows.
- 11) Measure the average transmitter conducted unwanted emissions levels during these MAC-Pilot-MAC windows using appropriate resolution bandwidth at the offset frequencies specified in the relevant table in clause 4.2.2.2 for the band class under assessment.
- 12) For limits specified in dBc: compare the measurements in step 11) with the carrier power measurements in step 10).
- 13) For limits specified in dBm: If the gated power measured in step 10) is lower than the carrier power measured in step 6) by more than 1 dB, add a correction factor equal to the difference of the carrier power levels, to the gated power measurements in steps 10) and 11).

NOTE: Case 2 measurements may be made using a spectrum analyser with time gated and RMS detection capabilities, by RF/IF triggering on alternate half-slots with delay to the next half-slot.

The results obtained from both case 1 and case 2 shall be compared to the limits in clause 4.2.2.2.1 for equipment operating in band class 5 and clause 4.2.2.2.2 for equipment operating in band class 11 and clause 4.2.2.2.3 for equipment operating in band class 12 in order to prove compliance.

5.3.2 Accuracy of maximum output power

The following test procedure shall be repeated at the:

- highest and lowest carrier frequency as declared by the manufacturer; and
- the carrier frequency as declared by the manufacturer which has the smallest positive offset from the median of these extreme carrier frequencies.

In addition at one carrier frequency the tests shall be carried out under extreme power supply and also test extreme temperature.

5.3.2.1 Test procedure for base stations supporting operation in 1X systems

Test environment: normal and extreme (for guidance see annex C).

- 1) Connect the power measuring equipment to the base station RF output port.
- 2) Configure the base station to operate in the band class under assessment and perform steps 3 and 4.
- 3) Set the base station to transmit a signal modulated with a combination of Pilot, Sync, Paging, and traffic channels as stated in ANSI/TIA-97-F [4], clause 6.5.2.
- 4) Measure the mean power at the RF output port.

The results obtained shall be compared to the limits in clause 4.2.3.2 in order to prove compliance.

5.3.2.2 Test procedure for base stations supporting operation in HRPD systems

Refer to TIA-864 [7], figure 11.5.1-1 for a functional block diagram of the test set-up.

- 1) Configure both the sector under test and an access terminal simulator as shown in TIA-864 [7], figure 11.5.1-1.
- 2) Connect the power measuring equipment to the sector RF output port.
- 3) Set up a test application session. Open a connection and configure the test application FTAP so that the forward traffic channel data rate corresponds to 2 457,6 kbit/s. Configure the MAC channel with 14 MAC indices, i.e. the RA channel and 13 RPC channels.
- 4) Measure the time response and the mean power of the sector output power averaged over at least 100 non-idle half slots. The power is measured at the sector's RF output port.

The results obtained shall be compared to the limits in clause 4.2.3.2 in order to prove compliance.

5.3.3 Radiated spurious emissions

For single carrier systems the following test procedure shall be repeated at the:

- highest and lowest carrier frequency as declared by the manufacturer; and
- the carrier frequency as declared by the manufacturer which has the smallest positive offset from the median of these extreme carrier frequencies.

For multiple carrier systems the following test procedure shall be performed with the system set to operate on the maximum number of contiguous carriers using the highest and lowest group of carrier frequencies as declared by the manufacturer.

5.3.3.1 Test method

- a) A test site fulfilling the requirements of ITU-R Recommendation SM.329-10 [9] shall be used. The EUT shall be placed on a non-conducting support and shall be operated from a power source via a RF filter to avoid radiation from the power leads.

Average power of any spurious components shall be detected by the test antenna and measuring receiver (e.g. a spectrum analyser). At each frequency at which a component is detected, the EUT shall be rotated and the height of the test antenna adjusted to obtain maximum response, and the effective radiated power (e.r.p.) of that component determined by a substitution measurement. The measurement shall be repeated with the test antenna in the orthogonal polarization plane.

NOTE: Effective radiated power (e.r.p.) refers to the radiation of a half wave tuned dipole instead of an isotropic antenna. There is a constant difference of 2,15 dB between e.i.r.p. and e.r.p.

$$\text{e.r.p. (dBm)} = \text{e.i.r.p. (dBm)} - 2,15 \text{ (ITU-R Recommendation SM.329-10 [9], annex 1).}$$

- b) The BS shall transmit with maximum power declared by the manufacturer with all transmitters active. Set the base station to transmit a signal as defined in the applicable part for measurement of spurious emissions.
- c) The video bandwidth shall be approximately three times the resolution bandwidth. If this video bandwidth is not available on the measuring receiver, it shall be the maximum available and at least 1 MHz.

5.3.3.2 Test configurations

This clause defines the configurations for emission tests as follows:

- the equipment shall be tested under normal test conditions as specified in the functional standards;
- the test configuration shall be as close to normal intended use as possible;
- if the equipment is part of a system, or can be connected to ancillary equipment, then it shall be acceptable to test the equipment while connected to the minimum configuration of ancillary equipment necessary to exercise the ports;
- if the equipment has a large number of ports, then a sufficient number shall be selected to simulate actual operation conditions and to ensure that all the different types of termination are tested;
- the test conditions, test configuration and mode of operation shall be recorded in the test report;
- ports which in normal operation are connected shall be connected to an ancillary equipment or to a representative piece of cable correctly terminated to simulate the input/output characteristics of the ancillary equipment, Radio Frequency (RF) input/output ports shall be correctly terminated;
- ports which are not connected to cables during normal operation, e.g. service connectors, programming connectors, temporary connectors etc. shall not be connected to any cables for the purpose of this test. Where cables have to be connected to these ports, or interconnecting cables have to be extended in length in order to exercise the EUT, precautions shall be taken to ensure that the evaluation of the EUT is not affected by the addition or extension of these cables.

For an EUT which contains more than one BS, it is sufficient to perform tests relating to connectors of each representative type of the BS forming part of the EUT.

At the manufacturer's discretion the test may be performed on the ancillary equipment separately or a representative configuration of the combination of radio and ancillary equipment. In each case the EUT is tested against all applicable emission clauses of the present document and in each case, compliance enables the ancillary equipment to be used with different radio equipment.

The results obtained shall be compared to the limits in clause 4.2.4.2 in order to prove compliance.

5.3.4 Inter-base station transmitter intermodulation

5.3.4.1 Test procedure for base stations supporting operation in 1X systems

- 1) Connect a spectrum analyser (or other suitable test equipment) and the external base station to the base station RF output port, using attenuators or directional couplers if necessary as shown in ANSI/TIA-97-F [4], figure 6.5.1-9.
- 2) Configure the base station to operate in the band class under assessment and perform steps 3 through 6.
- 3) Set the base station under test to transmit a signal modulated with a combination of Pilot, Sync, Paging, and traffic channels as stated in ANSI/TIA-97-F [4], clause 6.5.2. Total power at the RF output port shall be the maximum power as specified by the manufacturer.

- 4) Set the second base station to transmit a signal modulated with a combination of Pilot, Sync, Paging, and traffic channels as stated in ANSI/TIA-97-F [4], clause 6.5.2 with a total power that is 30 dB less than the power of the other base station with an offset of 1,25 MHz between the centre of the CDMA centre frequencies for spreading rate 1.
- 5) Measure the power level at the carrier frequency.
- 6) Measure the unwanted emission level at the image of the base station transmitter and the interference source. The image is centred at a frequency of 2 times the centre frequency of the base station under test minus the centre frequency of the second base station. The bandwidth of the image is the same as the bandwidth of the radio configuration in effect.

The results obtained shall be compared to the limits in clause 4.2.5.2 in order to prove compliance.

5.3.4.2 Test procedure for base stations supporting operation in HRPD systems 2

Refer to TIA-864 [7], figure 11.5.1-8 for a functional block diagram of the test set-up.

- 1) Connect the two sectors under test and two access terminal simulators as shown in TIA-864 [7], figure 11.5.1-8. Configure the set-up so that sector 2 total power is 30 dB less than the power of sector 1 with offsets of +1,25 MHz and -1,25 MHz between the centre of the CDMA centre frequencies.
- 2) Connect a spectrum analyser (or other suitable test equipment) to the sector 1 RF output port, using an attenuator or directional coupler if necessary.
- 3) Configure the sectors to operate in the band class under assessment and perform steps 4) through 19).

Case 1:

- 4) Set sector 1 to transmit Pilot, MAC and control channels (no connection is needed to allow having more idle slots).
- 5) Set sector 2 to transmit Pilot, MAC and control channels (no connection is needed to allow having more idle slots).
- 6) Measure the mean power level at the carrier frequency.
- 7) Measure the unwanted emission levels in the range specified in clause 4.2.2.2 of the present document.

Case 2:

- 8) Open a connection between sector 1 and access terminal simulator 1. Set access terminal simulator 1 to request non-null data rates for the duration of the test.
- 9) Set sector 2 to transmit Pilot, MAC and control channels (no connection is needed to allow having more idle slots).
- 10) Measure the mean power level at the carrier frequency.
- 11) Measure the unwanted emission levels in the range specified in clause 4.2.2.2 of the present document.

Case 3:

- 12) Set sector 1 to transmit Pilot, MAC and control channels (no connection is needed to allow having more idle slots).
- 13) Open a connection between sector 2 and access terminal simulator 2. Set access terminal simulator 2 to request non-null data rates for the duration of the test.
- 14) Measure the mean power level at the carrier frequency.
- 15) Measure the unwanted emission levels in the range specified in clause 4.2.2.2 of the present document.

Case 4:

- 16) Open a connection between sector 1 and access terminal simulator 1. Set access terminal simulator 1 to request non-null data rates for the duration of the test.
- 17) Open a connection between sector 2 and access terminal simulator 2. Set access terminal simulator 2 to request non-null data rates for the duration of the test.
- 18) Measure the mean power level at the carrier frequency.
- 19) Measure the unwanted emission levels in the range specified in clause 4.2.2.2 of the present document. The results obtained shall be compared to the limits in clause 4.2.5.2 in order to prove compliance.

5.3.5 Receiver conducted spurious emissions

5.3.5.1 Test procedure for base stations supporting operation in 1X or HRPD systems

- 1) Connect a spectrum analyser (or other suitable test equipment) to a receiver RF input port.
- 2) Configure the base station to operate in the band class under assessment and perform steps 3 through 5.
- 3) Disable all transmitter RF outputs.
- 4) Perform step 5 for all receiver input ports.
- 5) Sweep the spectrum analyser over a frequency range from 30 MHz to 12,75 GHz and measure the spurious emission level.

The results obtained shall be compared to the limits in clause 4.2.6.2 in order to prove compliance.

5.3.6 Single tone desensitization

The following test procedure shall be repeated at the:

- highest and lowest carrier frequency as declared by the manufacturer; and
- the carrier frequency as declared by the manufacturer which has the smallest positive offset from the median of these extreme carrier frequencies.

5.3.6.1 Test procedure

Refer to TIA-864 [7], figure 11.5.1-3 for a functional block diagram of the test set-up.

- 1) Configure the sector under test and an access terminal simulator as shown in TIA-864 [7], figure 11.5.1-3.
- 2) For each band class that the sector supports configure the sector to operate in that band class and perform steps 3 through 6.
- 3) Adjust the equipment to ensure path losses of at least 100 dB. All power control mechanisms shall be enabled and set at nominal values.
- 4) Set up a Test Application session. Open a connection and configure the Test Application RTAP so that the Reverse Data Channel data rate corresponds to 9,6 kbps.

- 5) Measure the access terminal simulator output power at the RF input ports of the sector, and the packet error rate at the access network.
- 6) For the band class and band subclass under test, adjust the CW generator and measure the access terminal simulator output power and packet error rate of the access network for each permutation shown in the table 9.

Table 9 CW Generator settings

| CW Generator Power Above Mobile Station Simulator Output Power | CW Generator Frequencies |
|----------------------------------------------------------------------------------------------------------------------------------------------------------------------------------------------------------------------------------------------------------------------------------------------------------------------------------------------------------------------------------------------------------------------------------------------|-----------------------------|
| 87 dB | f - 900 kHz and f + 900 kHz |
| NOTE: In this table, f is the frequency of each CDMA frequency assignment, f_1 is the lowest CDMA frequency assignment supported by the receiver, and f_2 is the highest CDMA frequency assignment supported by the receiver. For CW generator frequencies that are a function of f, repeat for each carrier supported by the receiver. The 40 dB specification is targeted for deployments in which only CDMA interferers are expected. | |

Annex A (normative): The HS Requirements and conformance Test specifications Table (HS-RTT)

| |
|----------------------------------------------------------------------------------------------------------------------------------------------------------------------------------------------------------------------------------------------------------------------------------------------------------|
| Notwithstanding the provisions of the copyright clause related to the text of the present document, ETSI grants that users of the present document may freely reproduce the HS-RTT proforma in this annex so that it can be used for its intended purposes and may further publish the completed HS-RTT. |
|----------------------------------------------------------------------------------------------------------------------------------------------------------------------------------------------------------------------------------------------------------------------------------------------------------|

This HS Requirements and conformance Test specifications Table (HS-RTT) serves a number of purposes, as follows:

- it provides a statement of all the essential requirements in words and by cross reference to a specific clause in the present document or to a specific clause in a specific referenced document;
- it provides a statement of all the test procedure corresponding to those essential requirements by cross reference to specific clause(s) in the present document or to a specific clause(s) in specific referenced document(s);
- it qualifies each requirement to be either:
 - Unconditional - meaning that the requirement applies in all circumstances; or
 - Conditional - meaning that the requirement is dependent on the supplier having chosen to support optional functionality defined within the schedule;
- in the case of Conditional requirements, it associates the requirement with the particular optional service or functionality;
- it qualifies each test procedure to be either:
 - Essential: meaning that it is included with the Essential Radio Test Suite and therefore the requirement shall be demonstrated to be met in accordance with the referenced procedures;
 - Other: meaning that the test procedure is illustrative but other means of demonstrating compliance with the requirement are permitted;
- when the schedule is completed in respect of a particular equipment including the testing outcomes, including a completed version of table A1 it provides a means to assert the "presumption of conformity" with the HS.

Table A.1: HS Requirements and conformance Test specifications Table (HS-RTT)

| Harmonized Standard EN 301 449 | | | | | | |
|-----------------------------------------------------------------------------------------------------------------------------------------------------|------------------------------------------------|----------------------|--------------------------------------|------------------------------------|--------------------|----------------------|
| The following technical requirements and test specifications are relevant to the presumption of conformity under article 3.2 of the R&TTE Directive | | | | | | |
| Technical Requirement reference | | | Technical Requirement Conditionality | | Test Specification | |
| No | Description | Reference: Clause No | U/C | Condition | E/O | Reference: Clause No |
| 1 | Transmitter conducted unwanted emissions | 4.2.2.2.1 | C | Applies to band class 5 equipment | E | 5.3.1 |
| 2 | Transmitter conducted unwanted emissions | 4.2.2.2.2 | C | Applies to band class 11 equipment | E | 5.3.1 |
| 3 | Transmitter conducted unwanted emissions | 4.2.2.2.3 | C | Applies to band class 12 equipment | E | 5.3.1 |
| 4 | Accuracy of maximum output power | 4.2.3 | U | | E | 5.3.2 |
| 5 | Radiated spurious emissions | 4.2.4 | U | | E | 5.3.3 |
| 6 | Inter-base station transmitter intermodulation | 4.2.5 | U | | E | 5.3.4 |
| 7 | Receiver conducted spurious emissions | 4.2.6 | U | | E | 5.3.5 |
| 8 | Single Tone Desensitization | 4.2.7 | U | | E | 5.3.6 |

Key to columns:**Essential Requirement:**

No A unique identifier for one row of the table which may be used to identify an essential requirement or its test specification.

Description A textual reference to the Technical Requirement

Clause Number:

Identification of clause(s) defining the technical requirement in the present document unless another document is referenced explicitly

Conditionality:

U/C Indicates whether the requirement is to be *unconditionally* applicable (U) or is *conditional* upon the manufacturers claimed functionality of the equipment (C)

Condition Explains the conditions when the requirement shall or shall not be applicable for a technical requirement which is classified "conditional"

Test Specification:

E/O Indicates whether the test specification forms part of the *Essential Radio Test Suite* (E) or whether it is one of the *Other Test Suite* (O)

NOTE: All tests whether "E" or "O" are relevant to technical requirements. Rows designated "E" collectively make up the Essential Radio Test Suite; those designated "O" make up the Other Test Suite; for those designated "X" there is no test specified corresponding to the technical requirements. All tests classified "E" shall be performed as specified with satisfactory outcomes is a necessary condition for a presumption of conformity. Technical requirements associated with tests classified "O" or "X" must be complied with as a necessary condition for presumption of conformity, although conformance with the requirement may be claimed by an equivalent test or by manufacturer's assertion supported by appropriate entries in the technical construction file.

Clause Number:

Identification of clause(s) defining the test specification in the present, document unless another document is referenced explicitly. Where no test is specified (that is, where the previous field is "X") this field remains blank.

Annex B (normative): Base station configurations

B.1 Receiver diversity

For each receiver, the tests in clause 5 of the present document shall be repeated with the specified test signals applied to one receiver antenna connector, with the remaining receivers disabled or their antenna connectors being terminated with 50 Ω .

B.2 Duplexers

The requirements of the present document shall be met with a duplexer fitted, if a duplexer is supplied as part of the BS. If the duplexer is supplied as an option by the manufacturer, sufficient tests should be repeated with and without the duplexer fitted to verify that the BS meets the requirements of the present document in both cases.

The following tests should be performed with the duplexer fitted, and without it fitted if this is an option:

- 1) clause 5.3.2, maximum output power, for the highest static power step only, if this is measured at the antenna connector;
- 2) clause 5.3.3, output RF spectrum emissions; outside the BS transmit band;
- 3) clause 5.3.4, inter-base station transmitter intermodulation; for the testing of conformance, the carrier frequencies should be selected to minimize intermodulation products from the transmitters falling in receive channels. The remaining tests may be performed with or without the duplexer fitted.

NOTE 1: When performing receiver tests with a duplexer fitted, it is important to ensure that the output from the transmitters does not affect the test apparatus. This can be achieved using a combination of attenuators, isolators and filters.

NOTE 2: When duplexers are used, intermodulation products will be generated, not only in the duplexer but also in the antenna system. The intermodulation products generated in the antenna system are not controlled by the specifications, and may degrade during operation (e.g. due to moisture ingress). Therefore, to ensure continued satisfactory operation of a BS, an operator will normally select CDMA channel numbers to minimize intermodulation products falling on receive channels. For testing of complete conformance, an operator may specify the CDMA channel numbers to be used.

B.3 Power supply options

If the BS is supplied with a number of different power supply configurations, it may not be necessary to test RF parameters for each of the power supply options, provided that it can be demonstrated that the range of conditions over which the equipment is tested is at least as great as the range of conditions due to any of the power supply configurations.

This applies particularly if a BS contains a DC rail which can be supplied either externally or from an internal mains power supply. In this case, the conditions of extreme power supply for the mains power supply options can be tested by testing only the external DC supply option. The range of DC input voltages for the test should be sufficient to verify the performance with any of the power supplies, over its range of operating conditions within the BS, including variation of mains input voltage, temperature and output current.

B.4 Ancillary RF amplifiers

The requirements of the present document shall be met with the ancillary RF amplifier fitted. At tests according to clause 5 for Tx and Rx respectively, the ancillary amplifier is connected to the BS by a connecting network (including any cable(s), attenuator(s), etc.) with applicable loss to make sure the appropriate operating conditions of the ancillary amplifier and the BS. The applicable connecting network loss range is declared by the manufacturer. Other characteristics and the temperature dependence of the attenuation of the connecting network are neglected. The actual attenuation value of the connecting network is chosen for each test as one of the applicable extreme values. The lowest value is used unless otherwise stated.

Sufficient tests should be repeated with the ancillary amplifier fitted and, if it is optional, without the ancillary RF amplifier to verify that the BS meets the requirements of the present document in both cases.

When testing, the following tests should be repeated with the optional ancillary amplifier fitted according to table B.1, where X denotes that the test is applicable:

Table B.1: Table of tests applicable to Ancillary RF Amplifiers

| | Clause | Tx amplifier only | Rx amplifier only | Tx/Rx amplifiers combined (see note) |
|---------------------------------------------------------------------------------------------------------------------------------------------------------------------------------------|--------|-------------------|-------------------|--------------------------------------|
| Receiver Tests | 5.3.4 | | X | |
| | 5.3.5 | | X | X |
| | 5.3.6 | | X | X |
| Transmitter Tests | 5.3.1 | X | | X |
| | 5.3.2 | X | | X |
| | 5.3.3 | X | | X |
| NOTE: Combining can be by duplex filters or any other network. The amplifiers can either be in Rx or Tx branch or in both. Either one of these amplifiers could be a passive network. | | | | |

In test according to clause 5.3.1, the highest applicable attenuation value is applied.

B.5 BS using antenna arrays

A BS may be configured with a multiple antenna port connection for some or all of its transceivers or with an antenna array related to one cell (not one array per transceiver). This clause applies to a BS which meets at least one of the following conditions:

- the transmitter output signals from one or more transceiver appear at more than one antenna port; or
- there is more than one receiver antenna port for a transceiver or per cell and an input signal is required at more than one port for the correct operation of the receiver thus the outputs from the transmitters as well as the inputs to the receivers are directly connected to several antennas (known as "aircombining"); or

NOTE: Diversity reception does not meet this requirement.

- transmitters and receivers are connected via duplexers to more than one antenna.

If a BS is used, in normal operation, in conjunction with an antenna system which contains filters or active elements which are necessary to meet the requirements, the conformance tests may be performed on a system comprising the BS together with these elements, supplied separately for the purposes of testing. In this case, it must be demonstrated that the performance of the configuration under test is representative of the system in normal operation, and the conformance assessment is only applicable when the BS is used with the antenna system.

For conformance testing of such a BS, the following procedure may be used.

B.5.1 Receiver tests

For each test, the test signals applied to the receiver antenna connectors shall be such that the sum of the powers of the signals applied equals the power of the test signal(s) specified in the test.

An example of a suitable test configuration is shown in figure B.1.

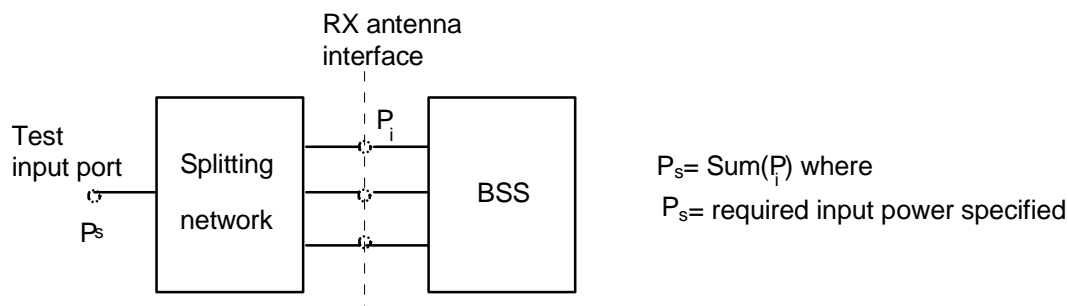

Figure B.1: Receiver test set-up

For spurious emissions from the receiver antenna connector, the test may be performed separately for each receiver antenna connector.

B.5.2 Transmitter tests

For each test, the test signals applied to the transmitter antenna connectors (P_i) shall be such that the sum of the powers of the signals applied equals the power of the test signal(s) (P_s) specified in the test. This may be assessed by separately measuring the signals emitted by each antenna connector and summing the results, or by combining the signals and performing a single measurement. The characteristics (e.g. amplitude and phase) of the combining network should be such that the power of the combined signal is maximized.

An example of a suitable test configuration is shown in figure B.2.

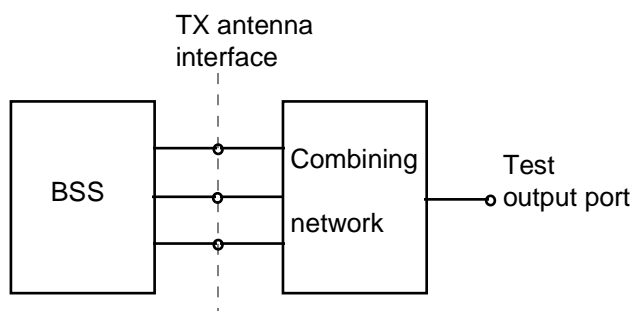

Figure B.2: Transmitter test set-up

For inter-base station transmitter intermodulation, the test may be performed separately for each transmitter antenna connector.

Annex C (normative): Environmental profile specification

C.1 Test conditions, power supply and ambient temperatures

C.1.1 Normal and extreme test conditions

Testing shall be performed under normal test conditions and where stated in the test procedures for all radio test suites (see clause C.1.3), under extreme conditions (see clause C.1.4).

Exceptions to the measurement procedures given in this clause shall be recorded.

C.1.2 Power sources

C.1.2.1 Power sources for stand-alone equipment

During testing, the power source of the equipment shall be replaced by a test power source capable of producing normal and extreme test voltages as specified in clauses C.1.3.2 and C.1.4.2. The internal impedance of the test power source shall be low enough for its effect on the test results to be negligible. For the purpose of tests, the voltage of the power source shall be measured at the input terminals of the equipment.

For battery operated equipment the battery shall be removed and the test power source shall be applied as close to the battery terminals as practicable.

During tests the power source voltages shall be maintained within a tolerance of ± 1 % relative to the voltage at the beginning of each test. The value of this tolerance is critical to power measurements; using a smaller tolerance will provide better measurement uncertainty values.

C.1.3 Normal test conditions

C.1.3.1 Normal temperature and humidity

The normal temperature and humidity conditions for tests shall be any convenient combination of temperature and humidity within the following ranges:

- temperature: $+15^{\circ}\text{C}$ to $+35^{\circ}\text{C}$;
- relative humidity: 20 % to 75 %.

When it is impracticable to carry out the tests under these conditions, a note to this effect, stating the ambient temperature and relative humidity during the tests, shall be recorded.

The actual values during the tests shall be recorded.

The maximum measurement uncertainty shall be:

- temperature: $\leq \pm 1$ K;
- humidity: $\leq \pm 5$ %.

C.1.3.2 Normal power source

C.1.3.2.1 Mains voltage

The normal test voltage for equipment to be connected to the mains shall be the nominal mains voltage. For the purpose of the present document, the nominal voltage shall be the voltage(s) for which the equipment was designed.

The frequency of the test power source corresponding to the AC mains shall be between 49 Hz and 51 Hz.

C.1.3.2.2 Lead-acid battery power sources used on vehicles

When radio equipment is intended for operation from the usual, alternator fed lead-acid battery power source used on vehicles, then the normal test voltage shall be 1,1 times the nominal voltage of the battery (6 V, 12 V, etc.).

C.1.3.2.3 Other power sources

For operation from other power sources or types of battery (primary or secondary), the nominal test voltage shall be as stated by the equipment manufacturer. This shall be recorded.

C.1.4 Extreme test conditions

C.1.4.1 Extreme temperatures

For tests at extreme temperatures, measurements shall be made in accordance with the procedures specified in clause C.1.4.3, at the upper and lower temperatures of the range as follows:

- temperature: -20°C to +55°C.

Where the manufacturer's stated operating range does not include the range of -20°C to +55°C, the equipment shall be tested over the following temperature ranges:

- a) 0°C to +35°C for equipment intended for indoor use only, or intended for use in areas where the temperature is controlled within this range;
- b) over the extremes of the operating temperature range(s) of the stated combination(s) or host equipment(s) in case of plug-in radio devices.

The output power limit (clause 5.3.2) shall not be exceeded.

The temperature range used during testing shall be recorded and shall be stated in the test report.

C.1.4.2 Extreme power source voltages

Tests at extreme power source voltages specified below are not required when the equipment under test is designed for operation as part of and powered by another system or piece of equipment. Where this is the case, the limit values of the host equipment or combined equipment shall apply. The appropriate limit values shall be stated by the provider and recorded.

C.1.4.2.1 Mains voltage

The extreme test voltage for equipment to be connected to an AC mains source shall be the nominal mains voltage $\pm 15\%$.

C.1.4.2.2 Power sources using other types of batteries

The lower extreme test voltages for equipment with power sources using the following types of battery shall be:

- for the Leclanché or lithium type battery: 0,85 times the nominal voltage of the battery;
- for the mercury or nickel-cadmium type of battery: 0,9 times the nominal voltage of the battery.

In both cases, the upper extreme test voltage shall be 1,15 times the nominal voltage of the battery.

C.1.4.2.3 Other power sources

For equipment using other power sources, or capable of being operated from a variety of power sources (primary or secondary), the extreme test voltages shall be those stated by the manufacturer and shall be recorded.

C.1.4.3 Procedure for tests at extreme temperatures

Before measurements are made the equipment shall have reached thermal balance in the test chamber.

The equipment shall be switched off during the temperature stabilizing period. In the case of equipment containing temperature stabilizing circuits designed to operate continuously, these circuits shall be switched on for 15 minutes after thermal balance has been reached. After this time the equipment shall meet the specified requirements. For this type of equipment the manufacturer shall provide for the power source circuit feeding these circuits to be independent of the power source of the rest of the equipment.

If thermal balance is not checked by measurements, a temperature stabilizing period of at least one hour, or such period as may be decided by the testing laboratory, shall be allowed. The sequence of measurements shall be chosen and the humidity content in the test chamber shall be controlled so that excessive condensation does not occur.

Before tests at the upper extreme temperature, the equipment shall be placed in the test chamber and left until thermal balance is attained.

For tests at the lower extreme temperature, the equipment shall be left in the test chamber until thermal balance is attained, then switched to the standby or receive condition for a period of one minute after which the equipment shall meet the specified requirements.

C.2 Declared environmental operating conditions of equipment

The following environmental conditions shall be declared by the supplier:

- barometric pressure: minimum and maximum;
- temperature: minimum and maximum;
- relative humidity: minimum and maximum;
- power supply: lower and upper voltage limit.

Annex D (informative): Bibliography

- Directive 98/34/EC of the European Parliament and of the Council of 22 June 1998 laying down a procedure for the provision of information in the field of technical standards and regulations.
- ECC Report 38: "The Technical Impact of introducing CDMA-PAMR in the 870-876 / 915-921 MHz band on 12.5 kHz UIC DMO & 200 kHz GSM-R radio systems".
- TIA/EIA/IS-856-1 (2002): "cdma2000® High Rate Packet Data Air Interface Specification - Addendum 1".
- ECC Report 25, Stavanger, May 2003: "Strategies for the European use of frequency spectrum for PMR/PAMR applications".

Annex E (informative): The EN title in the official languages

| Language | EN title |
|------------|----------------------------------------------------------------------------------------------------------------------------------------------------------------------------------------------------------------------------------------------------------------------------------------------------------------------------------------------------------------------------|
| Czech | Elektromagnetická kompatibilita a rádiové spektrum (ERM) - Harmonizovaná EN pro základnové stanice CDMA s rozprostřeným spektrem pracující v buňkovém pásmu 450 MHz (CDMA 450) a pásmech PAMR 410, 450 a 870 MHz (CDMA/PAMR), pokrývající základní požadavky článku 3.2 Směrnice R&TTE |
| Danish | Elektromagnetisk kompatibilitet og spektrumanliggender (ERM) – Harmoniseret EN for CDMA direkte spredt (UTRA) basisstationer, der benytter frekvensbåndet for cellulære radionet omkring 450 MHz (CDMA 450) og frekvensbånd for offentlige radionet (PAMR) ved 410, 450 og 870 MHz (CDMA-PAMR), der dækker de væsentlige krav i R&TTE direktivets artikel 3.2 |
| Dutch | Elektromagnetische compatibiliteit en radiospectrumaangelegenheden (ERM); Geharmoniseerde EN voor CDMA spread spectrum basis stations werkend in de 450 MHz-band (CDMA 450) en 410, 450 en 870 MHz PAMR banden (CDMA-PAMR) welke invulling geeft aan de essentiële eisen van artikel 3.2 van de R&TTE Richtlijn |
| English | Electromagnetic compatibility and Radio spectrum Matters (ERM); Harmonized EN for CDMA spread spectrum base stations operating in the 450 MHz cellular band (CDMA 450) and 410, 450 and 870 MHz PAMR bands (CDMA-PAMR) covering essential requirements of article 3.2 of the R&TTE Directive |
| Estonian | Elektromagnetilise ühilduvuse ja raadiospektri küsimused (ERM); Kärgrõõm raadiosagedusalas 450 MHz töötavate (CDMA 450) ja PAMR raadiosagedusalades 410 MHz, 450 MHz ja 870 MHz töötavate (CDMA-PAMR) hajaspektri CDMA baasjaamade põhinõuded, harmoneeritud EN R&TTE direktiivi artikli 3.2 alusel. |
| Finnish | Sähkömagneettinen yhteensopivuus ja radiospektriasiat (ERM); Yhdenmukaistettu standardi (EN), joka kattaa R&TTE-direktiivin artiklan 3.2 mukaiset olennaiset vaatimukset CDMA-hajaspektritekniikkaa käyttäville 450 MHz:n taajuuskaistalla toimiville tukiasemille (CDMA 450) ja 410, 450 ja 870 MHz:n PAMR- taajuuskaistoilla toimiville tukiasemille (CDMA-PAMR) |
| French | Compatibilité électromagnétique et Radioélectrique (ERM); Norme harmonisée EN pour les stations de base CDMA à étalement de spectre fonctionnant dans la bande cellulaire 450 MHz (CDMA450) et les bandes PAMR 410, 450, et 870 MHz couvrant les exigences essentielles de l'article 3.2 de la Directive R&TTE |
| German | Elektromagnetische Verträglichkeit und Funkspektrumaangelegenheiten (ERM); Harmonisierte EN für CDMA Spreizspektrum Feststationen betrieben in dem 450 MHz Band (CDMA 450) und 410, 450 und 870 MHz PAMR Bändern (CDMA-PAMR) mit wesentlichen Anforderungen nach R&TTE-Richtlinie Artikel 3.2 |
| Greek | Ηλεκτρομαγνητική συμβατότητα και Θέματα Ηλεκτρομαγνητικού Φάσματος (ERM); |
| Hungarian | |
| Icelandic | |
| Italian | Compatibilità elettromagnetica e problematiche di Spettro Radio (ERM); Norma Europea armonizzata per stazioni base CDMA a spettro espanso operanti nella banda di frequenza a 450 MHz delle reti cellulari (CDMA 450) e nelle bande PAMR a 410, 450 e 870 MHz (CDMA-PAMR) relativa ai requisiti essenziali dell'articolo 3.2 della direttiva R & TTE |
| Latvian | |
| Lithuanian | Elektromagnetinio suderinamumo ir radijo dažnių spektro dalykai. Darnusis CDMA išplėstojo spektro bazinių stočių, veikiančių 450 MHz korinėje juostoje (CDMA 450) ir 410 MHz, 450 MHz ir 870 MHz PAMR juostose (CDMA – PAMR), Europos standartas, apimantis esminius 1999/5/EC [1]* direktyvos 3.2 straipsnio reikalavimus |
| Maltese | Kompatibilità elettromanjetika u materji relatati ma' spettru radjofoniku (ERM); EN armonizzata għal stazzjonijiet b"bażi bi spettru mferrex li jopera fil-medda ċellulari ta" 450 MHz (CDMA 450) u fil-meded 410, 450 u 870 MHz PAMR (CDMA-PAMR) li jkopri rekwiżiti essenzjali taħt l-artiklu 3.2 tad-Direttiva R&TTE |
| Norwegian | Elektromagnetisk kompatibilitet og radiospektrumspørsmål (ERM); Harmonisert EN for CDMA spredt spektrum basestasjoner som opererer i det celledelte båndet 450 MHz (CDMA 450) og 410, 450 og 870 MHz PAMR båndene (CDMA-PAMR) som dekker de grunnleggende krav i R&TTE-direktivets artikkel 3.2 |
| Polish | Kompatybilność elektromagnetyczna i zagadnienia widma radiowego (ERM) - Zharmonizowana EN dotycząca stacji bazowych o rozproszonym widmie systemu CDMA pracującego w pasmie telekomunikacji komórkowej 450 MHz (CADM 450) oraz systemu PAMR pracującego w pasmach 410, 450 i 870 MHz (CADM PAMR) zapewniająca spełnienie zasadniczych wymagań artykułu 3.2 dyrektywy R&TTE |
| Portuguese | Compatibilidade electromagnética e questões relacionadas com o espectro de rádio, EN ajustado para estações rádio-base com espectro, operando em banda celular de 450 MHz bandas (CDMA 450) e 410, 450 e 870 MHz PAMR (CDMA-PAMR) satisfazendo requisitos essenciais do artigo 3.2 da diretiz R&TTE |

| Language | EN title |
|-----------|--------------------------------------------------------------------------------------------------------------------------------------------------------------------------------------------------------------------------------------------------------------------------------------------------------------------------|
| Slovak | |
| Slovenian | Elektromagnetna združljivost in zadeve v zvezi z radijskim spektrom (ERM) - Harmonizirani EN za bazne postaje, delujoče po standardu CDMA na razpršenem spektru v mobilnem pasu 450 MHz (CDMA 450) in pasovih PAMR 410, 450 ter 870 (CDMA-PAMR), ki zajema bistvene zahteve člena 3.2 direktive R&TTE |
| Spanish | Compatibilidad Electromagnética y Asuntos relacionados con el Espectro de Radio; Armonizado EN para estación base de espectro esparcido CDMA operando en la banda celular de 450 MHz Bandas (CDMA 450) and 410, 450 and 870 MHz PAMR (CDMA-PAMR) cubriendo requisitos esenciales del artículo 3.2 de la directiva RT&TTE |
| Swedish | Elektromagnetisk kompatibilitet och radiospektrumfrågor (ERM); Harmoniserad EN för CDMA spread spectrum basstationer som används i 450 MHz bandet (CDMA 450) och i 410, 450 and 870 MHz PAMR-banden (CDMA-PAMR) omfattande väsentliga krav enligt artikel 3.2 i R&TTE-direktivet |

History

| Document history | | | |
|-------------------------|----------|----------------|---------------------------------------|
| V1.1.1 | May 2005 | Public Enquiry | PE 20050909: 2005-05-11 to 2005-09-09 |
| V1.1.1 | May 2006 | Vote | V 20060714: 2006-05-15 to 2006-07-14 |
| | | | |
| | | | |
| | | | |