



**Satellite Earth Stations and Systems (SES);  
Land Mobile Earth Stations (LMES) and  
Maritime Mobile Earth Stations (MMES)  
providing voice and/or data communications,  
operating in the 1,5 GHz and 1,6 GHz frequency bands;  
Harmonised Standard for access to radio spectrum**

---

**Reference**

REN/SES-00416

---

**Keywords**

earth station, LMES, regulation, satellite

**ETSI**

---

650 Route des Lucioles  
F-06921 Sophia Antipolis Cedex - FRANCE

Tel.: +33 4 92 94 42 00 Fax: +33 4 93 65 47 16

Siret N° 348 623 562 00017 - NAF 742 C  
Association à but non lucratif enregistrée à la  
Sous-Préfecture de Grasse (06) N° 7803/88

---

**Important notice**

The present document can be downloaded from:

<http://www.etsi.org/standards-search>

The present document may be made available in electronic versions and/or in print. The content of any electronic and/or print versions of the present document shall not be modified without the prior written authorization of ETSI. In case of any existing or perceived difference in contents between such versions and/or in print, the prevailing version of an ETSI deliverable is the one made publicly available in PDF format at [www.etsi.org/deliver](http://www.etsi.org/deliver).

Users of the present document should be aware that the document may be subject to revision or change of status.

Information on the current status of this and other ETSI documents is available at

<https://portal.etsi.org/TB/ETSIDeliverableStatus.aspx>

If you find errors in the present document, please send your comment to one of the following services:

<https://portal.etsi.org/People/CommitteeSupportStaff.aspx>

---

**Copyright Notification**

No part may be reproduced or utilized in any form or by any means, electronic or mechanical, including photocopying and microfilm except as authorized by written permission of ETSI.

The content of the PDF version shall not be modified without the written authorization of ETSI.

The copyright and the foregoing restriction extend to reproduction in all media.

© ETSI 2020.

All rights reserved.

**DECT™**, **PLUGTESTS™**, **UMTS™** and the ETSI logo are trademarks of ETSI registered for the benefit of its Members.

**3GPP™** and **LTE™** are trademarks of ETSI registered for the benefit of its Members and of the 3GPP Organizational Partners.

**oneM2M™** logo is a trademark of ETSI registered for the benefit of its Members and of the oneM2M Partners.

**GSM®** and the GSM logo are trademarks registered and owned by the GSM Association.

# Contents

Intellectual Property Rights .....	6
Foreword.....	6
Modal verbs terminology.....	6
Introduction .....	7
1 Scope .....	8
2 References .....	8
2.1 Normative references .....	8
2.2 Informative references.....	9
3 Definition of terms, symbols and abbreviations.....	9
3.1 Terms.....	9
3.2 Symbols.....	10
3.3 Abbreviations .....	10
4 Technical requirement specifications .....	11
4.1 Environmental profile.....	11
4.2 Conformance requirements .....	11
4.2.0 Maximum EIRP .....	11
4.2.0.1 Justification .....	11
4.2.0.2 Specification.....	11
4.2.0.3 Conformance test .....	11
4.2.1 Unwanted emissions outside the band 1 625,8 MHz to 1 661,2 MHz and outside the band 1 667,3 MHz to 1 675,7 MHz .....	12
4.2.1.1 Justification .....	12
4.2.1.2 Specification.....	12
4.2.1.3 Conformance test .....	14
4.2.2 Maximum unwanted emissions within the band 1 625,8 MHz to 1 661,2 MHz and within the band 1 667,3 MHz to 1 675,7 MHz .....	14
4.2.2.1 Justification .....	14
4.2.2.2 Specifications .....	14
4.2.2.3 Conformance test .....	15
4.2.3 Control and Monitoring Functions (CMF).....	15
4.2.3.1 General .....	15
4.2.3.2 Processor monitoring .....	16
4.2.3.2.1 Justification .....	16
4.2.3.2.2 Specification .....	16
4.2.3.2.3 Conformance test.....	16
4.2.3.3 Transmit subsystem monitoring.....	16
4.2.3.3.1 Justification .....	16
4.2.3.3.2 Specification .....	16
4.2.3.3.3 Conformance test.....	16
4.2.3.4 Power-on/reset .....	16
4.2.3.4.1 Justification .....	16
4.2.3.4.2 Specification .....	16
4.2.3.4.3 Conformance test.....	16
4.2.3.5 Control Channel (CC) reception .....	17
4.2.3.5.1 Justification .....	17
4.2.3.5.2 Specification .....	17
4.2.3.5.3 Conformance test.....	17
4.2.3.6 Network control commands .....	17
4.2.3.6.1 Justification .....	17
4.2.3.6.2 Specification .....	17
4.2.3.6.3 Conformance test.....	17
4.2.3.7 Initial burst transmission .....	18
4.2.3.7.1 Justification .....	18
4.2.3.7.2 Specification .....	18

4.2.3.7.3	Conformance test.....	18
4.2.4	Protection of the radio astronomy service operation in the band 1 660,0 MHz to 1 660,5 MHz and in the band 1 668,0 MHz to 1 670,0 MHz .....	18
4.2.4.1	Purpose.....	18
4.2.4.2	Technical requirements .....	18
4.2.4.3	Conformance test .....	18
4.2.5	Receiver Adjacent Channel Selectivity.....	18
4.2.5.1	Justification .....	18
4.2.5.2	Specification.....	18
4.2.5.3	Conformance test .....	19
4.2.6	Receiver Blocking Characteristics .....	19
4.2.6.1	Justification .....	19
4.2.6.2	Specification.....	19
4.2.6.3	Conformance test .....	19
5	Testing for compliance with technical requirements.....	19
5.1	Environmental conditions for testing .....	19
5.2	Radio test suites.....	20
5.2.1	General.....	20
5.2.2	Measurement of unwanted emissions .....	20
5.2.2.1	General .....	20
5.2.2.2	Test site .....	21
5.2.2.3	Test method.....	21
5.2.2.3.1	Installation .....	21
5.2.2.3.2	Receive test equipment.....	21
5.2.2.4	Procedure .....	22
5.2.2.4.1	Test arrangements.....	22
5.2.2.4.2	Unwanted emissions up to 1 000 MHz.....	23
5.2.2.4.3	Unwanted emissions above 1 000 MHz .....	23
5.2.3	LMES and MMES Control and Monitoring Functions (CMF).....	24
5.2.3.1	General .....	24
5.2.3.2	Test arrangement.....	24
5.2.3.3	Processor monitoring .....	25
5.2.3.3.1	Test method .....	25
5.2.3.4	Transmit subsystem monitoring.....	25
5.2.3.4.1	Test method .....	25
5.2.3.5	Power-on/Reset .....	26
5.2.3.5.1	Test method .....	26
5.2.3.6	Control Channel (CC) reception .....	26
5.2.3.6.1	Test method .....	26
5.2.3.7	Network control commands .....	27
5.2.3.7.1	Test method .....	27
5.2.3.8	Initial burst transmission .....	28
5.2.3.8.1	Test method .....	28
5.2.4	Receiver Adjacent Channel Selectivity.....	28
5.2.4.1	General .....	28
5.2.4.2	Test arrangement.....	28
5.2.4.3	Test procedures .....	29
5.2.5	Receiver Blocking Characteristics .....	29
5.2.5.1	General .....	29
5.2.5.2	Test arrangement.....	29
5.2.5.3	Test procedures .....	29
5.2.6	EIRP.....	30
5.2.6.1	General .....	30
5.2.6.2	Test site .....	30
5.2.6.3	Test method.....	30
5.2.6.4	Procedure .....	30
5.2.6.4.1	Test arrangements.....	30
5.2.6.4.2	Maximum EIRP .....	30

<b>Annex A (informative):</b>	<b>Relationship between the present document and the essential requirements of Directive 2014/53/EU .....</b>	<b>31</b>
-------------------------------	---	-----------

<b>Annex B (informative):</b>	<b>Maximum Measurement Uncertainty.....</b>	<b>33</b>
<b>Annex C (informative):</b>	<b>Applicability of parameters given in ETSI EG 203 336 .....</b>	<b>34</b>
<b>Annex D (informative):</b>	<b>Bibliography.....</b>	<b>38</b>
History .....		39

---

## Intellectual Property Rights

### Essential patents

IPRs essential or potentially essential to normative deliverables may have been declared to ETSI. The information pertaining to these essential IPRs, if any, is publicly available for **ETSI members and non-members**, and can be found in ETSI SR 000 314: "*Intellectual Property Rights (IPRs); Essential, or potentially Essential, IPRs notified to ETSI in respect of ETSI standards*", which is available from the ETSI Secretariat. Latest updates are available on the ETSI Web server (<https://ipr.etsi.org/>).

Pursuant to the ETSI IPR Policy, no investigation, including IPR searches, has been carried out by ETSI. No guarantee can be given as to the existence of other IPRs not referenced in ETSI SR 000 314 (or the updates on the ETSI Web server) which are, or may be, or may become, essential to the present document.

### Trademarks

The present document may include trademarks and/or tradenames which are asserted and/or registered by their owners. ETSI claims no ownership of these except for any which are indicated as being the property of ETSI, and conveys no right to use or reproduce any trademark and/or tradename. Mention of those trademarks in the present document does not constitute an endorsement by ETSI of products, services or organizations associated with those trademarks.

---

## Foreword

This draft Harmonised European Standard (EN) has been produced by ETSI Technical Committee Satellite Earth Stations and Systems (SES), and is now submitted for the combined Public Enquiry and Vote phase of the ETSI standards EN Approval Procedure.

The present document has been prepared under the Commission's standardisation request C(2015) 5376 final [i.3] to provide one voluntary means of conforming to the essential requirements of Directive 2014/53/EU on the harmonisation of the laws of the Member States relating to the making available on the market of radio equipment and repealing Directive 1999/5/EC [i.6].

Once the present document is cited in the Official Journal of the European Union under that Directive, compliance with the normative clauses of the present document given in table A.1 confers, within the limits of the scope of the present document, a presumption of conformity with the corresponding essential requirements of that Directive and associated EFTA regulations.

<b>Proposed national transposition dates</b>	
Date of latest announcement of this EN (doa):	3 months after ETSI publication
Date of latest publication of new National Standard or endorsement of this EN (dop/e):	6 months after doa
Date of withdrawal of any conflicting National Standard (dow):	18 months after doa

---

## Modal verbs terminology

In the present document "**shall**", "**shall not**", "**should**", "**should not**", "**may**", "**need not**", "**will**", "**will not**", "**can**" and "**cannot**" are to be interpreted as described in clause 3.2 of the [ETSI Drafting Rules](#) (Verbal forms for the expression of provisions).

"**must**" and "**must not**" are **NOT** allowed in ETSI deliverables except when used in direct citation.

---

## Introduction

Following the WRC-03 decision [i.4] to allocate to MSS the bands 1 518 MHz to 1 525 MHz (space to Earth) and 1 668 MHz to 1 675 MHz (Earth to space) and the conclusions of WRC-07 [i.5], a new set of emission requirements for LMESs and MMESs that are capable of transmitting in the frequency band from 1 668,0 MHz to 1 675,0 MHz is specified.

The two parts of the L-band frequency allocations are treated as two sub-bands which may be used separately or in any combination. The standard L-band allocation is referenced in the present document as "sub-band 1" and the extended L-band is referenced as "sub-band 2".

Table 2c is applicable for LMESs and MMESs that are capable of transmitting in any combination of either or both of these sub-bands. Table 2c is recommended for all new LMESs and MMESs including LMES and MMES that can only operate in sub-band 1.

The manufacturer may choose between tables 2b and 2c for new LMESs and MMES that are capable of transmitting in only the sub-band 1. The manufacturer has to declare which alternative is used.

The present document specifies a new set of receiver performance requirements for LMESs and MMESs under the new Radio Equipment Directive 2014/53/EU [i.6].

### Figure 1: Void

The present document is intended to cover the provisions of Directive 2014/53/EU [i.6] (RE Directive) article 3.2 which states that "...radio equipment shall be so constructed that it both effectively uses and supports the efficient use of radio spectrum in order to avoid harmful interference".

Recital 10 of Directive 2014/53/EU [i.6] states that "*in order to ensure that radio equipment uses the radio spectrum effectively and supports the efficient use of radio spectrum, radio equipment should be constructed so that: in the case of a transmitter, when the transmitter is properly installed, maintained and used for its intended purpose it generates radio waves emissions that do not create harmful interference, while unwanted radio waves emissions generated by the transmitter (e.g. in adjacent channels) with a potential negative impact on the goals of radio spectrum policy should be limited to such a level that, according to the state of the art, harmful interference is avoided; and, in the case of a receiver, it has a level of performance that allows it to operate as intended and protects it against the risk of harmful interference, in particular from shared or adjacent channels, and, in so doing, supports improvements in the efficient use of shared or adjacent channels*".

Recital 11 of Directive 2014/53/EU [i.6] states that "*although receivers do not themselves cause harmful interference, reception capabilities are an increasingly important factor in ensuring the efficient use of radio spectrum by way of an increased resilience of receivers against harmful interference and unwanted signals on the basis of the relevant essential requirements of Union harmonisation legislation*".

As a consequence, the present document includes both transmitting and receiving parameters aiming to maximize the efficient use of radio spectrum.

# 1 Scope

The present document applies to Land Mobile Earth Stations (LMESs) and Maritime Mobile Earth Stations (MMESs) radio equipment with an EIRP of greater than or equal to 15 dBW and less than or equal to 33 dBW and which have the following characteristics:

- the LMES could be either vehicle mounted or portable equipment;
- these MMESs are installable equipment on ships;
- these LMESs and MMESs are controlled and monitored by a Network Control Facility (NCF). The NCF is outside the scope of the present document;
- the LMES and MMES operate through geostationary satellites as part of a network providing voice and/or data communications;
- these LMESs and MMESs operate with user bit-rates greater than 9,6 kbits/s;
- the LMES and MMESs are capable of operating in any combination of all or any part of the frequency ranges sub-band 1 and sub-band 2 defined in table 1a.

**Table 1a: Land and Maritime Mobile Satellite Service frequency bands**

Sub-Band	Direction of transmission	LMSS frequency bands
1	Transmit 1 (Earth to space)	1 626,5 MHz to 1 660,5 MHz
	Receive 1 (space to Earth)	1 525,0 MHz to 1 559,0 MHz
2	Transmit 2 (Earth to space)	1 668,0 MHz to 1 675,0 MHz
	Receive 2 (space to Earth)	1 518,0 MHz to 1 525,0 MHz

The present document is intended to cover the provisions of Directive 2014/53/EU [i.6] (RE Directive) article 3.2 which states that "...radio equipment shall be so constructed that it both effectively uses and supports the efficient use of radio spectrum in order to avoid harmful interference".

NOTE: The relationship between the present document and essential requirements of article 3.2 of Directive 2014/53/EU [i.6] is given in annex A.

## 2 References

### 2.1 Normative references

References are either specific (identified by date of publication and/or edition number or version number) or non-specific. For specific references, only the cited version applies. For non-specific references, the latest version of the referenced document (including any amendments) applies.

Referenced documents which are not found to be publicly available in the expected location might be found at <https://docbox.etsi.org/Reference/>.

NOTE: While any hyperlinks included in this clause were valid at the time of publication, ETSI cannot guarantee their long term validity.

The following referenced documents are necessary for the application of the present document.

- [1] Void.
- [2] CISPR 16-1-4 (2019): "Specification for radio disturbance and immunity measuring apparatus and methods - Part 1-4: Radio disturbance and immunity measuring apparatus - Antennas and test sites for radiated disturbance measurements".
- [3] Void.



- [4] Void.
- [5] Void.
- [6] Void.

## 2.2 Informative references

References are either specific (identified by date of publication and/or edition number or version number) or non-specific. For specific references, only the cited version applies. For non-specific references, the latest version of the referenced document (including any amendments) applies.

NOTE: While any hyperlinks included in this clause were valid at the time of publication, ETSI cannot guarantee their long term validity.

The following referenced documents are not necessary for the application of the present document but they assist the user with regard to a particular subject area.

- [i.1] Void.
- [i.2] Void.
- [i.3] Commission Implementing Decision C(2015) 5376 final of 4.8.2015 on a standardisation request to the European Committee for Electrotechnical Standardisation and to the European Telecommunications Standards Institute as regards radio equipment in support of Directive 2014/53/EU of the European Parliament and of the Council.
- [i.4] World Radiocommunication Conference 2003 (WRC-03) Final Acts.
- [i.5] World Radiocommunication Conference 2007 (WRC-07) Finals Acts.
- [i.6] Directive 2014/53/EU of the European Parliament and of the Council of 16 April 2014 on the harmonisation of the laws of the Member States relating to the making available on the market of radio equipment and repealing Directive 1999/5/EC (RE Directive).
- [i.7] The latest version of the ITU Master International Frequency Register (MIFR), available from the ITU website.
- [i.8] ETSI EG 203 336 (V1.2.1): "Guide for the selection of technical parameters for the production of Harmonised Standards covering article 3.1(b) and article 3.2 of Directive 2014/53/EU".

---

## 3 Definition of terms, symbols and abbreviations

### 3.1 Terms

For the purposes of the present document, the terms given in Directive 2014/53/EU [i.6] and the following apply:

**antenna transmit gain:** ratio, expressed in decibels, of the power that would have to be supplied to an isotropic radiator to the power supplied to the antenna being considered, so that they produce the same field strength at the same distance in the same direction

**carrier-off state:** state in which the LMES or MMES is not transmitting a carrier

**carrier-on state:** state in which the LMES or MMES is transmitting a carrier

**Control Channel (CC):** channel or channels by which LMES and MMES receive control information from the NCF for their network

**effective receive operating band:** receive band within 1 518 MHz to 1 559 MHz where the tests associated with table 5 are met; the effective receive operating band shall be indicated by the manufacturer

**environmental profile:** range of environmental conditions under which equipment within the scope of the present document is required to comply with the provisions of the present document

**Externally Mounted Equipment (EME):** equipment consisting of those of the modules of the Installable Equipment (IE) which are intended to be mounted externally to the vehicle as stated by the manufacturer

**in-band signals:** signals which are located in the operating band plus an offset of 10 MHz outside this operating band

**Installable Equipment (IE):** equipment which is intended to be fitted to a vehicle

NOTE: An IE may consist of one or several interconnected modules.

**Internally Mounted Equipment (IME):** modules of the IE which are not declared by the manufacturer as EME are defined as Internally Mounted Equipment (IME)

**manufacturer:** any natural or legal person who manufactures radio equipment or has radio equipment designed or manufactured, and markets that equipment under his name or trade mark

**nominated bandwidth:** bandwidth of the LMES or MMES radio frequency transmission nominated by the manufacturer

NOTE: The nominated bandwidth is wide enough to encompass all spectral elements of the transmission which have a level greater than the specified unwanted emissions limits. The nominated bandwidth is wide enough to take account of the transmit carrier frequency stability. The nominated bandwidth is within the transmit frequency band within which the LMES and MMES operates.

**operating band:** frequency range over which the receiving equipment is able to operate as intended

**Portable Equipment (PE):** equipment generally intended to be self-contained, free standing and portable

NOTE: A PE would normally consist of a single module, but may consist of several interconnected modules.

**sub-band:** contiguous portion of the operating band

NOTE: Two sub-bands are defined (see table 1a).

**transition frequency:** frequency which separates adjacent frequency ranges in a table of limits

**unwanted emissions:** emissions falling outside the nominated bandwidth

## 3.2 Symbols

Void.

## 3.3 Abbreviations

For the purposes of the present document, the following abbreviations apply:

BW	BandWidth
CC	Control Channel
CDMA	Code-Division Multiple Access
CISPR	International Special Committee on Radio Interference
CMF	Control and Monitoring Functions
CW	Continuous Wave
EFTA	European Free Trade Association
EIRP	Equivalent Isotropically Radiated Power
EMC	ElectroMagnetic Compatibility
EME	Externally Mounted Equipment
ETS	European Telecommunication Standard
EUT	Equipment Under Test
HS	Harmonised Standard
IE	Installable Equipment
IME	Internally Mounted Equipment

LMES	Land Mobile Earth Station
LMSS	Land Mobile Satellite Service
LO	Local Oscillator
LTE	Long Term Evolution
MES	Mobile Earth Station
MMES	Maritime Mobile Earth Station
MSS	Mobile Satellite Service
NCF	Network Control Facility
PE	Portable Equipment
R&TTE	Radio and Telecommunications Terminal Equipment
RA	Radio Astronomy
RE	Radio Equipment
RED	Radio Equipment Directive
RF	Radio Frequency
SNR	Signal to Noise Ratio
STE	Special Test Equipment
TBR	Technical Basis for Regulation
TC-SES	Technical Committee-Satellite Earth Stations and Systems
WRC	World Radiocommunication Conference

---

## 4 Technical requirement specifications

### 4.1 Environmental profile

The technical requirements of the present document apply under the environmental profile for operation of the equipment, which shall be in accordance with its intended use. The equipment shall comply with all the technical requirements of the present document at all times when operating within the boundary limits of the operational environmental profile defined by its intended use. The environmental profile for operation of the equipment shall include the ranges of humidity, temperature and supply voltage.

### 4.2 Conformance requirements

#### 4.2.0 Maximum EIRP

##### 4.2.0.1 Justification

Protection of other radio services from in band emissions.

##### 4.2.0.2 Specification

The EIRP of the LMES and MMES shall not exceed 33 dBW.

##### 4.2.0.3 Conformance test

Conformance test shall be carried out in accordance with clause 5.2.6.

## 4.2.1 Unwanted emissions outside the band 1 625,8 MHz to 1 661,2 MHz and outside the band 1 667,3 MHz to 1 675,7 MHz

### 4.2.1.1 Justification

The technical requirements presented in this clause shall apply to all LMESs and MMESs that are capable of transmitting either in sub-band 1 or sub-band 2, or in both sub-bands as defined in table 1a for the purpose of:

- protection of terrestrial and satellite services from emissions caused by LMES and MMES outside the band 1 625,8 MHz to 1 661,2 MHz; and
- protection of terrestrial and satellite services from emissions caused by LMES and MMES outside the band 1 667,3 MHz to 1 675,7 MHz.

### 4.2.1.2 Specification

Unwanted emissions from LMESs and MMESs outside the band 1 625,8 MHz to 1 661,2 MHz and outside the band 1 667,3 MHz to 1 675,7 MHz shall be below the following limits.

Unless otherwise stated the specification in this clause shall apply to all types of LMESs and MMESs notwithstanding their transmitting capabilities within the frequency bands as defined in table 1a.

The lower limit shall apply at the transition frequency.

- 1) The unwanted emissions over the frequency range 30 MHz to 1 000 MHz shall not exceed the limits in table 1b.

**Table 1b: Limits of unwanted emissions up to 1 000 MHz at a measuring distance of 10 m**

Frequency (MHz)	Quasi-peak limits (dB(μV/m))	Measurement Bandwidth (kHz)
30 to 230	30	100
230 to 1 000	37	100

- 2) For LMES and MMES that are capable of transmitting within only the sub-band 1 frequency band as defined in table 1a, the unwanted emissions Equivalent Isotropically Radiated Power (EIRP) above 1 000 MHz in the measurement bandwidth and in all directions shall not exceed limits of either tables 2b or 2c. Which alternative to use shall be determined by the intended use as indicated by the manufacturer.
- 3) For LMES and MMES that are capable of transmitting within only the sub-band 2 frequency band or within both sub-band 1 and sub-band 2 frequency bands as defined in table 1a, the unwanted emissions Equivalent Isotropically Radiated Power (EIRP) above 1 000 MHz in the measurement bandwidth and in all directions shall not exceed the limits in table 2c.

**Table 2a: Void**

**Table 2b: Limits of unwanted emissions above 1 000 MHz and outside the band 1 625,8 MHz to 1 661,2 MHz**

Frequency range (MHz)	Carrier-on		Carrier-off	
	EIRP limit (dBpW)	Measurement bandwidth (kHz)	EIRP limit (dBpW)	Measurement bandwidth (kHz)
1 000,0 to 1 525,0	49	100	48	100
1 525,0 to 1 559,0	49	100	17	3
<b>1 559,0 to 1 580,42</b>	<b>50</b>	<b>1 000</b>	<b>50</b>	<b>1 000</b>
<b>1 580,42 to 1 605,0</b>	<b>50</b>	<b>1 000</b>	<b>50</b>	<b>1 000</b>
<b>1 605,0 to 1 610,0</b>	<b>(note 5)</b>	<b>100</b>	<b>(note 6)</b>	<b>100</b>
1 610,0 to 1 625,8	74	100	48	100
1 625,8 to 1 661,2	(note 1)	(note 1)	(note 1)	(note 1)
1 661,2 to 1 690,0	74	100	48	100
1 690,0 to 3 400,0	49 (note 2)	100	48	100
3 400 to 10 700	55 (notes 3 & 4)	100	48	100
10 700 to 21 200	61	100	54	100
21 200 to 40 000	67	100	60	100

NOTE 1: The unwanted emissions in the band 1 625,8 MHz to 1 661,2 MHz are limited by clause 4.2.2.  
NOTE 2: In the band 3 253,0 MHz to 3 321,0 MHz the maximum EIRP in one, and only one, 100 kHz measurement bandwidth shall not exceed 82 dBpW. Elsewhere in this band the power limit in table 2b shall be applied.  
NOTE 3: In each of the bands 4 879,5 MHz to 4 981,5 MHz, 6 506,0 MHz to 6 642,0 MHz and 8 132,5 MHz to 8 302,5 MHz the maximum EIRP in one, and only one, 100 kHz measurement bandwidth shall not exceed 72 dBpW. Elsewhere in this band the power limit in table 2b shall be applied.  
NOTE 4: In the band 9 759,0 MHz to 9 963,0 MHz the maximum EIRP in one, and only one, 100 kHz measurement bandwidth shall not exceed 61 dBpW. Elsewhere in this band the power limit in table 2b shall be applied.  
NOTE 5: Linearly interpolated from 40 dBpW in 100 kHz at 1 605,0 MHz to 74 dBpW in 100 kHz at 1 610,0 MHz.  
NOTE 6: Linearly interpolated from 40 dBpW in 100 kHz at 1 605,0 MHz to 48 dBpW in 100 kHz at 1 610,0 MHz.

**Table 2c: Limits of unwanted emissions above 1 000 MHz and outside the band 1 625,8 MHz to 1 661,2 MHz and the band 1 667,3 MHz to 1 675,7 MHz**

Frequency range (MHz)	Carrier-on		Carrier-off	
	EIRP limit (dBpW)	Measurement bandwidth (kHz)	EIRP limit (dBpW)	Measurement bandwidth (kHz)
1 000,0 to 1 518	60	1 000	48 (note 7)	100
1 518,0 to 1 525,0	60	1 000	17	3
1 525,0 to 1 559,0	49	100	17	3
1 559,0 to 1 580,42	50	1 000	50	1 000
1 580,42 to 1 605,0	50	1 000	50	1 000
1 605,0 to 1 610,0	(note 5)	100	(note 6)	100
1 610,0 to 1 625,8	74	100	48	100
1 625,8 to 1 661,2	(note 1)	(note 1)	(note 1)	(note 1)
1 661,2 to 1 661,7	(note 8)	100	48	100
1 661,7 to 1 666,8	74	100	48	100
1 666,8 to 1 667,3	(note 9)	100	48	100
1 667,3 to 1 675,7	(note 2)	(note 2)	(note 2)	(note 2)
1 675,7 to 1 676,2	(note 10)	100	48	100
1 676,2 to 1 704,5	74	100	48	100
1 704,5 to 2 250,0	49	100	43 (note 7)	100
2 250,0 to 3 400,0	60 (note 3)	1 000	43 (note 7)	1 000
3 400 to 10 700	60 (note 4)	1 000	43 (note 7)	1 000
10 700 to 21 200	60	1 000	43 (note 7)	1 000
21 200 to 40 000	60	1 000	43 (note 7)	1 000

Frequency range (MHz)	Carrier-on		Carrier-off	
	EIRP limit (dBpW)	Measurement bandwidth (kHz)	EIRP limit (dBpW)	Measurement bandwidth (kHz)
NOTE 1:	The unwanted emissions in the band 1 625,8 MHz to 1 661,2 MHz are limited by clause 4.2.2.			
NOTE 2:	The unwanted emissions in the band 1 667,3 MHz to 1 675,7 MHz are limited by clause 4.2.2.			
NOTE 3:	In the band 3 253,0 MHz to 3 321,0 MHz and 3 336,0 MHz to 3 350,0 MHz the maximum EIRP in one, and only one, 3 MHz measurement bandwidth shall not exceed 82 dBpW. Elsewhere in this band the power limit in table 2c shall be applied.			
NOTE 4:	In the bands 4 879,5 MHz to 4 981,5 MHz and 5 004,0 MHz to 5 025,0 MHz the maximum EIRP in one, and only one, 3 MHz measurement bandwidth shall not exceed 72 dBpW. Elsewhere in this band the power limit in table 2c shall be applied. In the bands 6 506,0 MHz to 6 642,0 MHz and 6 672,0 MHz to 6 700,0 MHz the maximum EIRP in one, and only one, 3 MHz measurement bandwidth shall not exceed 72 dBpW. Elsewhere in this band the power limit in table 2c shall be applied. In the bands 8 132,5 MHz to 8 302,5 MHz and 8 340,0 MHz to 8 375,0 MHz the maximum EIRP in one, and only one, 3 MHz measurement bandwidth shall not exceed 72 dBpW. Elsewhere in this band the power limit in table 2c shall be applied.			
NOTE 5:	Linearly interpolated from 40 dBpW in 100 kHz at 1 605,0 MHz to 74 dBpW in 100 kHz at 1 610,0 MHz.			
NOTE 6:	Linearly interpolated from 40 dBpW in 100 kHz at 1 605,0 MHz to 48 dBpW in 100 kHz at 1 610,0 MHz.			
NOTE 7:	Peak-hold measurement methods shall be used for carrier-off limits in the band 1 000,0 MHz to 1 518,0 MHz and in all the bands from 1 704,5 MHz to 40 000 MHz. Otherwise average measurement methods should be used.			
NOTE 8:	For an LMES and MMES transmitting in sub-band 1 (as defined in table 1a) the limit shall be linearly interpolated from 80 dBpW in 100 kHz at 1 661,2 MHz to 74 dBpW in 100 kHz at 1 661,7 MHz. For an LMES and MMES transmitting in sub-band 2 (as defined in table 1a) a limit of 74 dBpW in 100 kHz shall apply.			
NOTE 9:	For an LMES and MMES transmitting in sub-band 2 (as defined in table 1a) the limit shall be linearly interpolated from 74 dBpW in 100 kHz at 1 666,8 MHz to 80 dBpW in 100 kHz at 1 667,3 MHz. For an LMES and MMES transmitting in sub-band 1 (as defined in table 1a) a limit of 74 dBpW in 100 kHz shall apply.			
NOTE 10:	For an LMES and MMES transmitting in sub-band 2 (as defined in table 1a) the limit shall be linearly interpolated from 80 dBpW in 100 kHz at 1 675,7 MHz to 74 dBpW in 100 kHz at 1 676,2 MHz. For an LMES and MMES transmitting in sub-band 1 (as defined in table 1a) a limit of 74 dBpW in 100 kHz shall apply.			

#### 4.2.1.3 Conformance test

Conformance test shall be carried out in accordance with clause 5.2.2.

### 4.2.2 Maximum unwanted emissions within the band 1 625,8 MHz to 1 661,2 MHz and within the band 1 667,3 MHz to 1 675,7 MHz

#### 4.2.2.1 Justification

The technical requirements presented in this clause shall apply to all LMESs and MMESs that are capable of transmitting either in sub-band 1, or sub-band 2, or in both sub-bands as defined in table 1a for the purpose of:

- protection of satellite and terrestrial services operating in the 1 625,8 MHz to 1 661,2 MHz frequency band; and
- protection of satellite and terrestrial services operating in the 1 667,3 MHz to 1 675,7 MHz frequency band.

#### 4.2.2.2 Specifications

If an LMES and MMES is capable of transmitting in both sub-band 1 and sub-band 2 as defined in table 1a, there are two different limits in this clause. The limits defined in table 3 shall only apply for the current transmit band as defined below.

##### Specification 1: Carrier-on state

For LMES and MMES transmitting in sub-band 1 (as defined in table 1a), the unwanted emission EIRP in any 3 kHz band within the 1 625,8 MHz to 1 661,2 MHz band, but outside the nominated bandwidth, shall not exceed the limits of table 3; and the emission limits within the 1 667,3 MHz to 1 675,7 MHz frequency band shall not exceed 74 dBpW in any 100 kHz measurement bandwidth.

NOTE 1: If a manufacturer states to use table 2b for an LMES and MMES the same emission limit for the 1 667,3 MHz to 1 675,7 MHz frequency band is also defined in table 2b.

For LMES and MMES transmitting in sub-band 2 (as defined in table 1a), the unwanted emission EIRP in any 3 kHz band within the 1 667,3 MHz to 1 675,7 MHz band, but outside the nominated bandwidth, shall not exceed the limits of table 3; and the emission limits within the 1 625,8 MHz to 1 661,2 MHz frequency band shall not exceed 74 dBpW in any 100 kHz measurement bandwidth.

**Table 3: Limits for unwanted emissions within the 1 625,8 MHz to 1 661,2 MHz band for terminals transmitting in sub-band 1 and within the 1 667,3 MHz to 1 675,7 MHz band for terminals transmitting in sub-band 2**

Offset from the edge of the band of the nominated bandwidth (kHz)	Maximum EIRP (dBpW)
0 to 10	125
10 to 20	110
20 to 100	105
100 to 200	95
200 to 700	85
Greater than 700	75

If a manufacturer states to use table 2b for an LMES and MMES the limits in table 3 may be exceeded provided that the sum in watts of the spectrum components exceeding the limits of table 3 does not exceed 104 dBpW. This additional requirement is retained for compatibility with the previous version of the present document.

#### **Specification 2: Carrier-off state**

For LMES and MMES which is capable of transmitting in either sub-band 2 only or in both sub-band 1 and sub-band 2 (as defined in table 1a), Specification 2a shall apply. This requirement shall also apply if an manufacturer states to use table 2c for LMES and MMES capable of transmitting in sub-band 1 only and should also apply if an manufacturer states to use table 2b.

- Specification 2a: The EIRP of any emission in any 100 kHz band within the 1 625,8 MHz to 1 661,2 MHz band and the 1 667,3 MHz to 1 675,7 MHz band shall not exceed 48 dBpW.

However, if an manufacturer states to use table 2b for LMES or MMES capable of transmitting in sub-band 1 only (as defined in table 1a), then Specification 2b shall apply:

- Specification 2b: The EIRP of any emission in any 3 kHz band within the 1 625,8 MHz to 1 661,2 MHz band and the 1 667,3 MHz to 1 675,7 MHz band shall not exceed 57 dBpW.

NOTE 2: Specification 2b is retained for compatibility with the previous version of the present document.

#### 4.2.2.3 Conformance test

Conformance test shall be carried out in accordance with clause 5.2.2.

### 4.2.3 Control and Monitoring Functions (CMF)

#### 4.2.3.1 General

The following minimum set of CMF shall be implemented in LMES and MMES in order to minimize the probability that they originate unwanted transmissions that may give rise to harmful interference to other systems.

Under any fault condition when the LMES and MMES transmissions are being suppressed the limits for carrier-off state shall apply.

#### 4.2.3.2 Processor monitoring

##### 4.2.3.2.1 Justification

To ensure that the LMES or MMES can suppress transmissions in the event of a processor sub-system failure.

##### 4.2.3.2.2 Specification

The LMES and MMES shall incorporate a processor monitoring function for each of its processors involved in the manipulation of traffic and in Control and Monitoring Functions (CMF).

The processor monitoring function shall detect any failure of the processor hardware and software.

No later than one second after any fault condition occurs, the LMES and MMES shall enter the carrier-off state until the processor monitoring function has determined that all fault conditions have been cleared.

##### 4.2.3.2.3 Conformance test

Conformance test shall be carried out in accordance with clause 5.2.3.3.

#### 4.2.3.3 Transmit subsystem monitoring

##### 4.2.3.3.1 Justification

To ensure the correct operation of the transmit frequency generation sub-system and to inhibit transmissions should the sub-system fail.

##### 4.2.3.3.2 Specification

The LMES and MMES shall monitor the operation of its transmit frequency generation sub-system.

No later than 5 seconds after any fault condition of the transmit frequency generation sub-system occurs, the LMES and MMES shall enter the carrier-off state until the transmit sub-system monitoring function has determined that all fault conditions have been cleared.

##### 4.2.3.3.3 Conformance test

Conformance test shall be carried out in accordance with clause 5.2.3.4.

#### 4.2.3.4 Power-on/reset

##### 4.2.3.4.1 Justification

To demonstrate that the LMES and MMES achieves a controlled non-transmitting state following the powering of the unit, or the occurrence of a reset made by a local operator when this function is implemented.

##### 4.2.3.4.2 Specification

During and following "power-on" or a manual reset when this function is implemented, the LMES and MMES shall remain in the carrier-off state.

##### 4.2.3.4.3 Conformance test

Conformance test shall be carried out in accordance with clause 5.2.3.5.



### 4.2.3.5 Control Channel (CC) reception

#### 4.2.3.5.1 Justification

To ensure that the LMES and MMES cannot transmit unless it correctly receives the Control Channel (CC) messages from the NCF.

#### 4.2.3.5.2 Specification

- a) without correct reception of the CC messages from the NCF, the LMES and MMES shall remain in the carrier-off state;
- b) the LMES and MMES shall enter the carrier-off state immediately after a period not exceeding 30 seconds without correct reception of the CC messages from the NCF.

#### 4.2.3.5.3 Conformance test

Conformance test shall be carried out in accordance with clause 5.2.3.6.

### 4.2.3.6 Network control commands

#### 4.2.3.6.1 Justification

These requirements ensure that the LMES and MMES is capable of:

- a) retaining a unique identification in the network and transmitting it upon reception of an appropriate request;
- b) receiving commands from the NCF through its Control Channel(s) (CCs) and executing those commands.

#### 4.2.3.6.2 Specification

The LMES and MMES shall hold, in non-volatile memory, its unique identification code in the network.

The LMES and MMES shall be capable of receiving through its Control Channel(s) (CCs) dedicated messages (addressed to the LMES and MMES) from the NCF, and which contain:

- transmission enable commands;
- transmission disable commands;
- identification request.

Once a transmission enable command is received the LMES and MMES is authorized to transmit.

After power-on or reset the LMES and MMES shall remain in the carrier-off state until it receives a transmission enable command. For systems where no transmission enable command is expected after power-on or reset the LMES and MMES may only transmit initial bursts (see clause 4.2.3.7).

Once a transmission disable command is received, within 1 second the LMES and MMES shall enter into, and shall remain in, the carrier-off state until the transmission disable command is superseded by a subsequent transmission enable command.

The LMES and MMES shall be capable of transmitting its identification code upon reception of an identification request.

#### 4.2.3.6.3 Conformance test

Conformance test shall be carried out in accordance with clause 5.2.3.7.

#### 4.2.3.7 Initial burst transmission

##### 4.2.3.7.1 Justification

To limit disturbance to other services.

##### 4.2.3.7.2 Specification

For systems where no transmission enable command is expected after power-on or reset the LMES and MMES may transmit initial bursts:

- a) the transmission of the initial burst shall not exceed 1 % of the time;
- b) each burst shall not last more than one second.

##### 4.2.3.7.3 Conformance test

Conformance test shall be carried out in accordance with clause 5.2.3.8.

#### 4.2.4 Protection of the radio astronomy service operation in the band 1 660,0 MHz to 1 660,5 MHz and in the band 1 668,0 MHz to 1 670,0 MHz

##### 4.2.4.1 Purpose

To protect the radio astronomy service in the 1 660,0 MHz to 1 660,5 MHz band and the 1 668,0 MHz to 1 670,0 MHz band from emissions produced by LMESs and MMESs the transmissions in these frequency bands shall be capable of being disabled in the vicinity of RA stations recorded in the ITU Master International Frequency Register [i.7].

##### 4.2.4.2 Technical requirements

The LMES and MMES shall be able to have its transmissions disabled as specified in clause 4.2.3.6.2.

The actual procedure used in an MSS network to protect the radio astronomy service in the 1 660,0 MHz to 1 660,5 MHz band and 1 668,0 MHz to 1 670,0 MHz band may utilize additional features of the LMES and MMES.

##### 4.2.4.3 Conformance test

Conformance tests shall be carried out in accordance with clause 5.2.3.7.1.

#### 4.2.5 Receiver Adjacent Channel Selectivity

##### 4.2.5.1 Justification

To enable reception of a wanted signal in presence of other signals in the adjacent channel.

Adjacent channel selectivity is a measure of a receiver's ability to receive a signal at its assigned channel frequency in the presence of a signal in the adjacent channel at a given frequency offset from the centre frequency of the assigned channel.

##### 4.2.5.2 Specification

The frequency offset and relative power level of the adjacent signal compared to the wanted signal shall take the values given in table 4. The adjacent signal shall occupy the same bandwidth as the wanted signal where BW is the wanted signal occupied bandwidth. There shall be no more than 0,5 dB degradation in the receiver signal to noise ratio under these conditions.

**Table 4: Adjacent Channel frequency and power level**

Signal	Centre frequency offset from wanted signal	Power level relative to wanted signal
Adjacent signal	BW	12 dB

#### 4.2.5.3 Conformance test

Conformance tests described in clause 5.2.4 shall be carried out.

### 4.2.6 Receiver Blocking Characteristics

#### 4.2.6.1 Justification

To prevent high power signals outside the receive frequency band from blocking the reception of wanted signals inside the receive frequency band.

#### 4.2.6.2 Specification

Receiver blocking response is a measure of the capability of the receiver to receive a wanted signal without exceeding a given degradation due to the presence of any other than the desired input signal at any frequency. It is defined as the maximum total signal level at the receiver input expressed in dBm reducing the specified receiver sensitivity (desensitization) by a certain number of decibels. As a test requirement, the blocking criterion is specified as the level of the unwanted signal at a given offset which will result in a 3 dB reduction in the wanted signal to noise ratio.

The receiver performance degradation, in terms of signal to noise ratio, shall not exceed 3 dB when the unwanted signal as specified in table 5 is present.

**Table 5: Interfering blocking signal characteristics**

Interfering Signal	Level (dBm)
5 MHz wide LTE carrier with centre frequency at 1 514,5 MHz and upper edge of carrier at 1 517 MHz	-30

The wanted carrier frequency centre shall be placed at the lowest possible carrier/channel assignment in the effective receive operating band.

The manufacturer shall state the effective receive operating band.

#### 4.2.6.3 Conformance test

Conformance tests described in clause 5.2.5 shall be carried out.

## 5 Testing for compliance with technical requirements

### 5.1 Environmental conditions for testing

Tests defined in the present document shall be carried out at representative points within the boundary limits of the operational environmental profile defined by its intended use.

Where technical performance varies subject to environmental conditions, tests shall be carried out under a sufficient variety of environmental conditions (within the boundary limits of the operational environmental profile defined by its intended use) to give confidence of compliance for the affected technical requirements.

## 5.2 Radio test suites

### 5.2.1 General

The values of measurement uncertainty associated with each measurement parameter apply to all of the test cases described in the present document. The measurement uncertainties shall not exceed the values shown in table B.1 in Annex B.

To enable the performance tests to be carried out the use of Special Test Equipment (STE), made available by the manufacturer may be necessary. Since this test equipment will be specific to the particular system, it is not possible to provide detailed specifications in the present document. However, the following baseline is provided:

- if the LMES and MMES requires to receive a modulated carrier from the satellite in order to transmit, then special test arrangements are required to simulate the satellite signal, thus enabling the LMES and MMES to transmit allowing measurement of transmission parameters;
- any characteristic of these special test arrangements which may have direct or indirect effects on the parameters to be measured shall be clearly stated by the manufacturer.

All tests in the carrier-on state shall be undertaken with the transmitter operating at the maximum power setting and with the maximum transmit burst rate where applicable.

All technical characteristics and operational conditions declared by the manufacturer shall be entered in the test report.

### 5.2.2 Measurement of unwanted emissions

#### 5.2.2.1 General

For purposes of the test, the EUT comprises:

- a) for IE:
  - the EME;
  - the IME;
  - interconnecting cables between IME and EME units as supplied by the manufacturer;
  - the necessary power supply cables and any other cable ensuring a proper functioning of the terminal;
- b) for PE:
  - for a single module PE, the module itself with any deployable parts in their normal operating configuration;
  - for a multiple module PE, all such modules with all necessary interconnecting cables of lengths as normally supplied by the manufacturer; again any deployable parts should be in their normal operating configuration.

For measurements up to 1 000 MHz the distance between the EUT and the measuring antenna shall be 10 m. For measurements above 1 000 MHz the distance between the EUT and the measuring antenna shall be such that the radiating near-field of each antenna shall not overlap with that of the other.

The highest frequency to which tests shall be performed shall be the 10<sup>th</sup> harmonic of the highest conversion frequency or ten times the highest transmit frequency, whichever is the greater.

The upper and lower extremes of the tuning range shall be stated by the manufacturer.

### 5.2.2.2 Test site

The test shall be performed either in an open area test site, a semi-anechoic chamber or an anechoic chamber. Ambient noise levels shall be at least 6 dB below the applicable unwanted emissions limit.

An open area test site shall be flat, free of overhead wires and nearby reflecting structures, sufficiently large to permit aerial placement at the specified measuring distance and provide adequate separation between aerial, test unit and reflecting structures.

A metal ground plane shall be inserted on the natural ground plane and it shall extend at least 1 m beyond the perimeter of the EUT at one end and at least 1 m beyond the measurement antenna at the other end.

### 5.2.2.3 Test method

#### 5.2.2.3.1 Installation

For IE, the EUT shall be installed with a separation of about 0,5 m between the IME and the EME, the maximum length connection cable specified by the manufacturer shall be installed. The height of the cable shall be between 0,5 m and 1 m. The cable shall be maintained in that position by non-metallic means. The EME shall be set, in its normal operating configuration on a non-metallic turn-table at a height between 0,5 m and 1 m. The IME shall be set on a non-metallic turn-table at a height of 0,8 m for tests up to 1 000 MHz and between 0,5 m and 1 m for tests above 1 000 MHz. Any associated equipment, e.g. portable computer or data terminal if required for operation of the LMES and MMES, shall be placed next to, and at the same height as, the IME.

For PE, the equipment shall be arranged in its normal operating configuration as recommended by the manufacturer on a non-metallic turn table at a height between 0,5 m and 1 m.

The EUT shall be terminated with matched impedance at the terrestrial ports if recommended by the manufacturer in the user documentation and if there is no associated equipment connected to such port.

For frequencies up to 80 MHz the measuring antenna shall be a balanced dipole which has a length equal to the 80 MHz resonant length and shall be matched to the feeder by a suitable transforming device. Measurements with broad band antennas are also possible provided that the test site has been calibrated according to the requirements of CISPR 16-1-4 [2].

For frequencies between 80 MHz and 1 000 MHz the measuring antenna shall be a balanced dipole which shall be resonant in length. Measurements with broad band antennas are also possible provided that the test site has been calibrated according to the requirements of CISPR 16-1-4 [2].

For frequencies above 1 000 MHz the antenna shall be a horn radiator of known gain/frequency characteristics. The antenna is mounted on a support capable of allowing the antenna to be used in either horizontal or vertical polarization and at the specified height.

For tests up to 1 000 MHz the receive test equipment shall be a measuring receiver. For tests above 1 000 MHz the receive test equipment shall be a spectrum analyser.

#### 5.2.2.3.2 Receive test equipment

##### 5.2.2.3.2.1 Measuring receiver for measurements up to 1 000 MHz

Measuring receivers shall conform to the following characteristics:

- the response to a constant amplitude sine wave signal shall remain within  $\pm 1$  dB across the frequency range of interest;
- quasi-peak detection shall be used in a -6 dB bandwidth of 120 kHz;
- the receiver shall be operated at more than 1 dB below the compression point during tests/measurements.

### 5.2.2.3.2.2 Spectrum analyser for measurements above 1 000 MHz

The spectrum analyser resolution bandwidth shall be set to the specified measuring bandwidth or as close as possible. If the resolution bandwidth is different from the specified measuring bandwidth, bandwidth correction shall be performed for noise-like wideband signals. The measuring system shall be capable of detecting signals at least 6 dB below the applicable unwanted emissions limit.

## 5.2.2.4 Procedure

### 5.2.2.4.1 Test arrangements

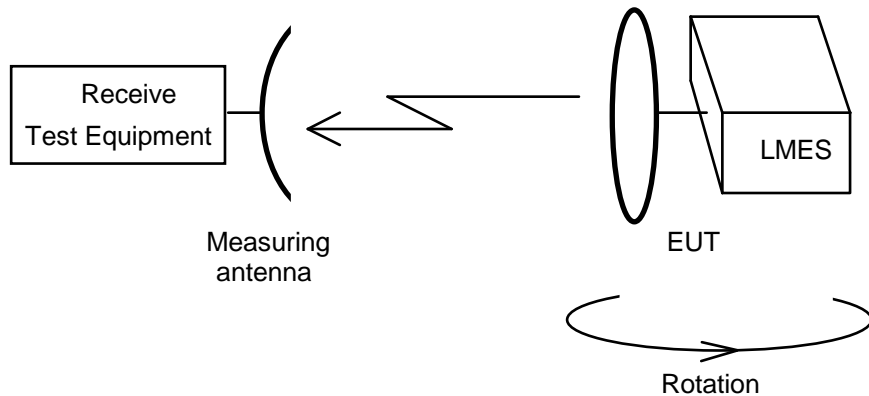

**Figure 2: Test arrangement - emissions measurement, first axis**

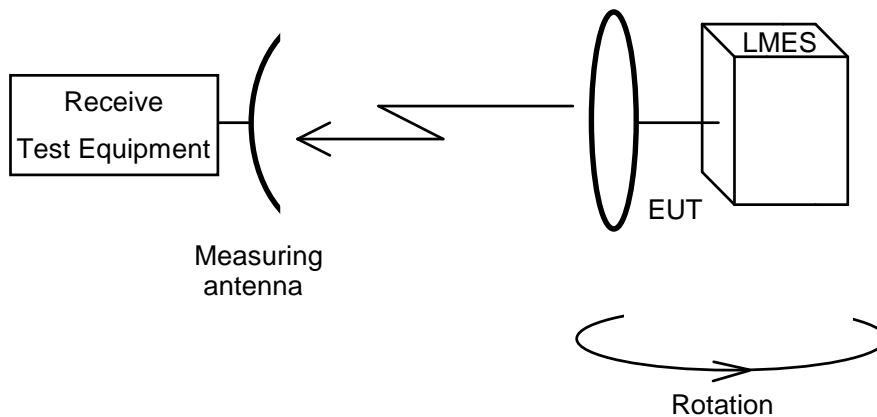

**Figure 3: Test arrangement for LMES and MMES - emissions measurement, second axis**

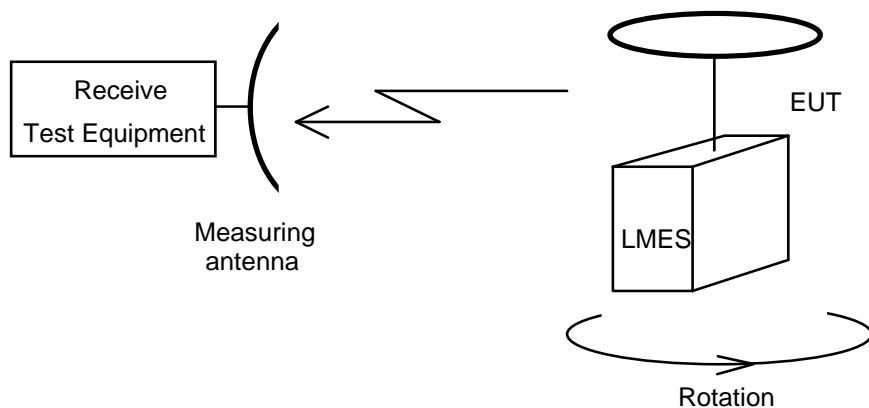

**Figure 4: Test arrangement for LMES and MMES - emissions measurement, third axis**

#### 5.2.2.4.2 Unwanted emissions up to 1 000 MHz

- a) The test arrangement shall be as shown in figure 2 with the measuring receiver installed. EUTs with adjustable antennas shall have the antenna boresight axis in the plane of rotation. The measuring antenna boresight axis shall coincide with the plane of rotation of the boresight of the EUT.
- b) The EUT shall be in the carrier-on state with the carrier at the lowest possible centre frequency, depending on the operating frequency band of the EUT, as defined in b.1) and b.2) below:
  - b.1) For EUT capable of transmitting in only one sub-band, either in sub-band 1 or sub-band 2 as defined in table 1a, then only the lowest possible centre frequency of the respective band shall be used.
  - b.2) For EUT capable of transmitting in both the sub-band 1 or sub-band 2 as defined in table 1a, the tests in c) and d) as described in this clause shall be repeated for the lowest possible centre frequency in each of the frequency bands.
- c) The EUT shall be rotated through 360° whilst unwanted emissions are measured in frequency and amplitude, over the frequency range 30 MHz to 1 000 MHz. The frequency and amplitude of each signal shall be noted.
- d) The measurements shall be repeated with the measuring antenna in the orthogonal polarization and the signal levels similarly noted.
- e) The tests in c) and d) above shall be repeated with the EUT carrier at the highest possible centre frequency, depending on the operating frequency band of the EUT, as defined in e.1) and e.2) below:
  - e.1) For EUT capable of transmitting in only one sub-band, either in sub-band 1 or sub-band 2 as defined in table 1a, then only the highest possible centre frequency of the respective band shall be used.
  - e.2) For EUT capable of transmitting in both the sub-band 1 or sub-band 2 as defined in table 1a, the tests in c) and d) as described in this clause shall be repeated for the highest possible centre frequency in each of the frequency bands.
- f) The tests in c) and d) above shall be repeated with the carrier-off.
- g) The tests in b) to f) above shall be repeated with the EUT turned so that its axis of rotation is orthogonal to that of the first case, as shown in figure 3. The EUT antenna boresight axis shall remain in the plane of rotation.
- h) The tests in b) to f) above shall be repeated with the EUT turned so that its axis of rotation is mutually orthogonal to those of the first two cases, as shown in figure 4. The EUT antenna boresight axis shall be perpendicular to the plane of rotation.

#### 5.2.2.4.3 Unwanted emissions above 1 000 MHz

- a) The test arrangement shall be as shown in figure 2 with the spectrum analyser installed. EUTs with adjustable antennas shall have the antenna boresight axis in the plane of rotation. The measuring antenna boresight axis shall coincide with the plane of rotation of the boresight of the EUT.
- b) The EUT shall be in the carrier-on state with the carrier at the lowest possible centre frequency, depending on the operating frequency band of the EUT, as defined in b.1) and b.2) below:
  - b.1) For EUT capable of transmitting only in one sub-band, either in sub-band 1 or sub-band 2 as defined in table 1a, then only the lowest possible centre frequency of the respective band shall be used.
  - b.2) For EUT capable of transmitting in both the sub-band 1 or sub-band 2 as defined in table 1a, the tests in c) and d) as described in this clause shall be repeated for the lowest possible centre frequency in each of the frequency bands.
- c) The EUT shall be rotated through 360° whilst unwanted emissions are measured in frequency and amplitude, over the frequency range 1 000 MHz to 40 GHz. The frequency and amplitude of each signal shall be noted.
- d) The measurements shall be repeated with the measuring antenna in the orthogonal polarization and the signal levels similarly noted.

- e) The tests in c) and d) above shall be repeated with the EUT carrier at the highest possible centre frequency, depending on the operating frequency band of the EUT, as defined in e.1) and e.2) below:
  - e.1) For EUT capable of transmitting only in one sub-band, either in sub-band 1 or sub-band 2 as defined in table 1a, then only the highest possible centre frequency of the respective band shall be used.
  - e.2) For EUT capable of transmitting in both the sub-band 1 or sub-band 2 as defined in table 1a, the tests in c) and d) as described in this clause shall be repeated for the highest possible centre frequency in each of the frequency bands.
- f) The tests in c) and d) above shall be repeated with the carrier-off.
- g) The tests in b) to f) above shall be repeated with the EUT turned so that its axis of rotation is orthogonal to that of the first case, as shown in figure 3. The EUT antenna boresight axis shall remain in the plane of rotation.
- h) The tests in b) to f) above shall be repeated with the EUT turned so that its axis of rotation is mutually orthogonal to those of the first two cases, as shown in figure 4. The EUT antenna boresight axis shall be perpendicular to the plane of rotation.

## 5.2.3 LMES and MMES Control and Monitoring Functions (CMF)

### 5.2.3.1 General

If the EUT is a LMES or MMES that has been modified by the manufacturer for these tests then full documentation of such modification(s) shall be provided to prove that the modification(s) will simulate the required test condition.

For the purpose of this test, the EUT is the LMES or MMES either with, or without its antenna connected.

The measurement of the EIRP spectral density shall be limited within either the nominated bandwidth or to a 10 MHz bandwidth centred on the carrier frequency whichever is the greater.

### 5.2.3.2 Test arrangement

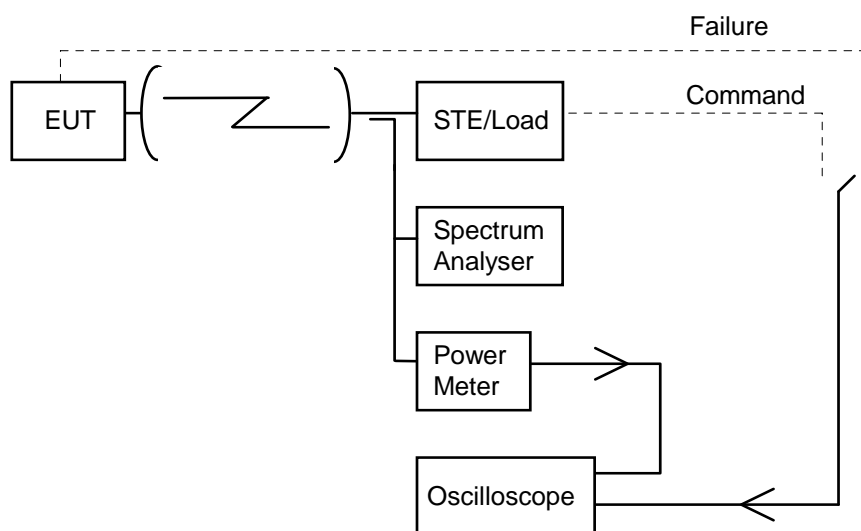

**Figure 5: General test arrangement for control and monitoring tests for radiated measurements**



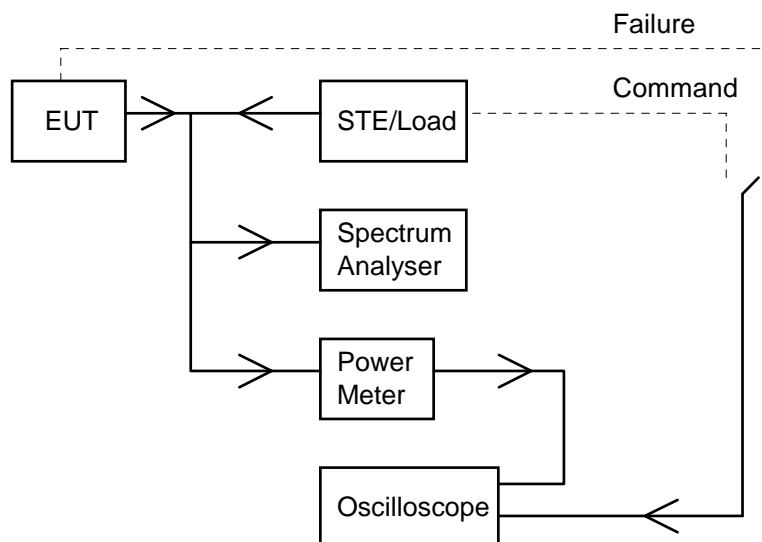

**Figure 6: General test arrangement for control and monitoring tests for conducted measurements**

The test arrangement shall be as shown in figure 5 or 6. The EUT shall be authorized to transmit and shall be in the carrier-on state at the commencement of each test, unless otherwise stated. The oscilloscope shall monitor by measuring the time difference between the command, or failure, and the occurrence of the expected event (e.g. the transmission suppression). The spectrum analyser and the power meter shall monitor the EUT output level.

### 5.2.3.3 Processor monitoring

#### 5.2.3.3.1 Test method

- a) Each of the processors within the EUT shall, in turn, be caused to fail.
- b) Within 1 second of such failure the EUT shall cease to transmit as measured by the oscilloscope.
- c) The power meter and spectrum analyser shall be observed to ascertain that the transmissions have been suppressed.
- d) The failed processor shall be restored to normal working condition and the EUT shall restore automatically to normal working before the next processor shall be induced to fail.

### 5.2.3.4 Transmit subsystem monitoring

#### 5.2.3.4.1 Test method

- a) The frequency lock subsystem within the EUT shall be caused to fail.
- b) Within 6 seconds of such failure the EUT shall cease to transmit as measured by the oscilloscope.
- c) The power meter and spectrum analyser shall be observed to ascertain that the transmissions have been suppressed.
- d) The failed elements shall be restored to normal working state and the EUT shall be restored to normal working.
- e) The frequency generation subsystem within the EUT shall be caused to fail.
- f) Within 6 seconds of such failure the EUT shall cease to transmit as measured by the oscilloscope.
- g) The power meter and spectrum analyser shall be observed to ascertain that the transmissions have been suppressed.

- h) The failed elements shall be restored to normal working state and the EUT shall be restored to normal working.

### 5.2.3.5 Power-on/Reset

#### 5.2.3.5.1 Test method

- a) The EUT shall be switched off and the STE shall not transmit the CC.
- b) The EUT shall be switched on.
- c) The EUT shall not transmit during and after switching-on, and shall enter the carrier-off state.

The events from a) to c) shall be displayed and verified with the oscilloscope and by measurement of the transmitted signal. If a manual reset function is implemented the following test shall be performed:

- d) The EUT shall be switched on and the STE shall transmit the CC.
- e) A call shall be initiated from the EUT and the EUT shall enter the carrier-on state.
- f) The reset function shall be initiated.
- g) The EUT shall enter the carrier-off state.

The event from e) to g) shall be displayed and verified with the oscilloscope and by measurement of the transmitted signal.

### 5.2.3.6 Control Channel (CC) reception

#### 5.2.3.6.1 Test method

The following tests shall be performed:

- Case a) where the CC has never been received by the EUT.
- Case b) where the CC is lost by the EUT during a transmission period of a call.
- Case c) where the CC is lost by the EUT during a period without transmission.
- Case d) where the CC is being lost by the EUT and a call is initiated within the Time-Out period T1.

The Time-Out period T1 used in the tests shall be 30 seconds.

- a) Case where the CC has never been received by the EUT:
  - a1) The EUT shall be switched off and the STE shall not transmit the CC.
  - a2) The EUT shall be switched on.
  - a3) A call shall be initiated from the EUT.
  - a4) The EUT shall remain in the carrier-off state.

The events from a2) to a4) shall be displayed and verified with the oscilloscope and by measurement of the transmit signal.

- b) Case where the CC is lost by the EUT during a transmission period of a call:
  - b1) The EUT shall be switched-on and the STE shall transmit the CC.
  - b2) A call shall be initiated from the EUT.
  - b3) The STE shall stop transmitting the CC.
  - b4) Within T1 from b3), the EUT shall enter the carrier-off state.

The events from b2) to b4) shall be displayed and verified with the oscilloscope and by measurement of the transmitted signal.

c) Case where the CC is lost by the EUT during a period without transmission:

- c1) The EUT shall be switched on and the STE shall transmit the CC.
- c2) The STE shall stop transmitting the CC.
- c3) More than T1 later, a call shall be initiated from the EUT.
- c4) The EUT shall remain in the carrier-off state.

The events from c2) to c4) shall be displayed and verified with the oscilloscope and by measurement of the transmitted signal.

d) Case where the CC is being lost by the EUT and a call is initiated within the T1 period:

- d1) The EUT shall be switched on and the STE shall transmit the CC.
- d2) The STE shall stop transmitting the CC.
- d3) Within the period T1 from d2), a call shall be initiated from the EUT.
- d4) The EUT may transmit but within the T1 period the EUT shall enter the carrier-off state.

The events from d2) to d4) shall be displayed and verified with the oscilloscope and by measurement of the transmitted signal.

### 5.2.3.7 Network control commands

#### 5.2.3.7.1 Test method

The following tests shall be performed in sequence:

a) Transmission enable command:

- a1) The EUT shall be switched-on and the STE shall transmit the CC.
- a2) The EUT shall enter the carrier-off state.
- a3) A call shall be initiated from the EUT, the EUT shall remain in the carrier-off state.
- a4) The STE shall transmit an enable command to the EUT.
- a5) A call shall be initiated from the EUT.
- a6) The EUT shall enter the carrier-on state and shall transmit.

The events from a2) to a6) shall be displayed and verified with the oscilloscope and by measurement of the transmitted signal.

b) Transmission disable command:

- b1) Continue from a6).
- b2) The STE shall transmit a disable command to the EUT.
- b3) The EUT shall enter the carrier-off state within 1 second.
- b4) A call shall be initiated from the EUT.
- b5) The EUT shall remain in the carrier-off state.
- b6) The STE shall transmit an enable command.
- b7) A call shall be initiated from the EUT.

b8) The EUT shall enter the carrier-on state and shall transmit.

b9) The call shall be terminated at the EUT.

The events from b2) to b9) shall be displayed and verified with the oscilloscope and by measurement of the transmitted signal.

c) Identification request:

c1) Continue from b9).

c2) The STE shall transmit an identification request.

c3) The EUT shall enter the carrier-on state and shall transmit its identification code.

The STE shall display the identification code sent by the EUT.

### 5.2.3.8 Initial burst transmission

#### 5.2.3.8.1 Test method

a) The EUT shall be switched-off and the STE shall transmit the CC.

b) The EUT shall be switched-on.

c) The EUT shall not transmit, except the initial bursts, if any.

d) Each initial burst shall not last more than 1 second, and the transmission of the initial bursts shall not exceed 1 % of the time.

The events from b) to d) shall be displayed and verified with the oscilloscope and by measurement of the transmitted signal.

## 5.2.4 Receiver Adjacent Channel Selectivity

### 5.2.4.1 General

If the EUT is a LMES or MMES that has been modified by the manufacturer for these tests then full documentation of such modification(s) shall be provided to prove that the modification(s) will simulate the required test condition.

For the purpose of this test, the EUT is the LMES or the MMES without its antenna connected.

### 5.2.4.2 Test arrangement

The equipment should be set-up as shown in figure 7.

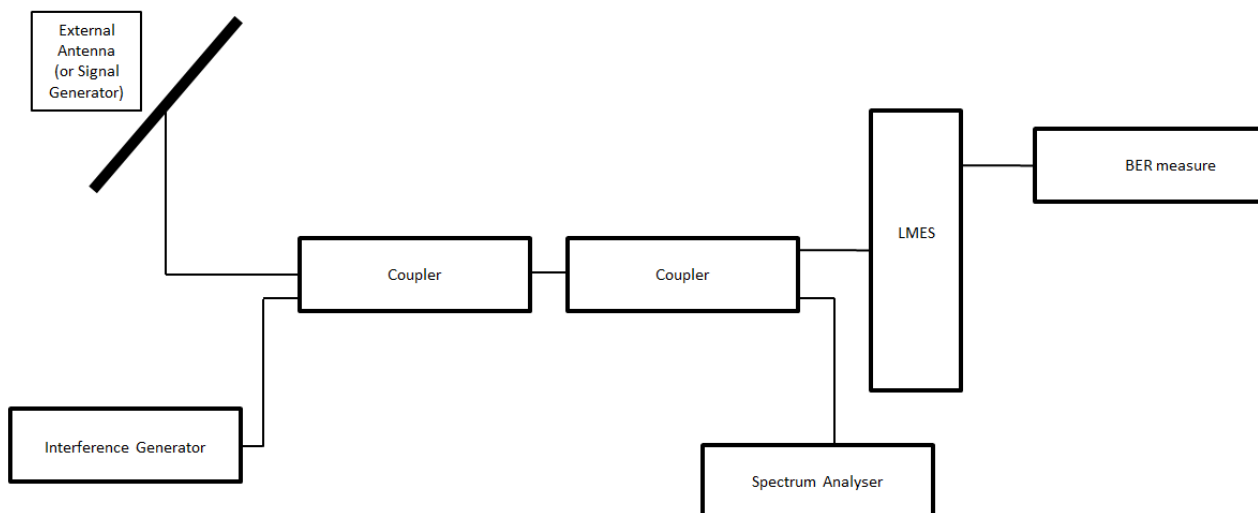

**Figure 7: Measuring system set-up for Adjacent Channel Selectivity and Blocking Characteristics (for LMES and MMES)**

### 5.2.4.3 Test procedures

The procedure basics are illustrated below:

- 1) The wanted signal power is adjusted such that the SNR (at the receiver input) is set to the reference level plus 1 dB. The reference level is the minimum SNR required to achieve the target performance level for a given bearer type.
- 2) Measure the SNR of the receiver, where SNR of the receiver means the SNR determined by the receiver demodulator.
- 3) Set the parameters of the interference signal generator as shown in table 4 in clause 4.2.5.2.
- 4) Add the interference signal and measure the SNR of the receiver.
- 5) The SNR achieved in step 3 shall not exceed 0,5 dB degradation compared to the SNR measured in step 2.

## 5.2.5 Receiver Blocking Characteristics

### 5.2.5.1 General

If the EUT is a LMES or MMES that has been modified by the manufacturer for these tests then full documentation of such modification(s) shall be provided to prove that the modification(s) will simulate the required test condition.

For the purpose of this test, the EUT is the LMES or MMES without its antenna connected.

### 5.2.5.2 Test arrangement

The equipment should be set-up as shown in figure 7.

### 5.2.5.3 Test procedures

- 1) The wanted carrier frequency centre is placed at the lowest possible carrier/channel assignment in the effective receive operating band and then the wanted carrier power is adjusted such that the SNR (at the receiver input) is set to the reference level plus 3 dB. The reference level is the minimum SNR required to achieve the target performance level for a given bearer type.
- 2) Measure the SNR of the receiver, where SNR of the receiver means the SNR determined by the receiver demodulator.

- 3) Generate the interfering blocking signal with the parameters as shown in table 5 in clause 4.2.6.2.
- 4) Apply the interfering blocking signal (generated in step 3) and measure the receiver SNR
- 5) The SNR achieved in step 4 shall not exceed 3 dB degradation compared to the SNR measured in step 2.

## 5.2.6 EIRP

### 5.2.6.1 General

See clause 5.2.2.1.

### 5.2.6.2 Test site

See clause 5.2.2.2.

### 5.2.6.3 Test method

See clause 5.2.2.3.

### 5.2.6.4 Procedure

#### 5.2.6.4.1 Test arrangements

See clause 5.2.2.4.1.

#### 5.2.6.4.2 Maximum EIRP

- a) The test arrangement shall be as shown in figure 2 with the spectrum analyser installed. EUTs with adjustable antennas shall have the antenna boresight axis in the plane of rotation. The measuring antenna boresight axis shall coincide with the plane of rotation of the boresight of the EUT.
- b) The EUT shall be in the carrier-on state with the carrier at the lowest possible frequency in sub-band 1 or sub-band 2 as defined in table 1a.
- c) The EUT shall be rotated through 360° whilst the amplitude of emissions is recorded.
- d) The tests in b) and c) above shall be repeated with the EUT carrier at the highest possible frequency in sub-band 1 or sub-band 2 as defined in table 1a.
- e) The tests in b) to d) above shall be repeated with the EUT turned so that its axis of rotation is orthogonal to that of the first case, as shown in figure 3. The EUT antenna boresight axis shall remain in the plane of rotation.
- f) The tests in b) to d) above shall be repeated with the EUT turned so that its axis of rotation is mutually orthogonal to those of the first two cases, as shown in figure 4. The EUT antenna boresight axis shall be perpendicular to the plane of rotation.
- g) The measurements shall be used to calculate EIRP and the maximum shall not exceed 33 dBW.

## Annex A (informative): Relationship between the present document and the essential requirements of Directive 2014/53/EU

The present document has been prepared under the Commission's standardisation request C(2015) 5376 final [i.3] to provide one voluntary means of conforming to the essential requirements of Directive 2014/53/EU on the harmonisation of the laws of the Member States relating to the making available on the market of radio equipment and repealing Directive 1999/5/EC [i.6].

Once the present document is cited in the Official Journal of the European Union under that Directive, compliance with the normative clauses of the present document given in table A.1 confers, within the limits of the scope of the present document, a presumption of conformity with the corresponding essential requirements of that Directive and associated EFTA regulations.

**Table A.1: Relationship between the present document and the essential requirements of Directive 2014/53/EU**

Harmonised Standard ETSI EN 301 444					
Requirement				Requirement Conditionality	
No	Description	Essential requirements of Directive	Clause(s) of the present document	U/C	Condition
0	Maximum EIRP	3.2	4.2.0	U	
1	Unwanted emissions outside the band 1 625,8 MHz to 1 661,2 MHz and outside the band 1 667,3 MHz to 1 675,7 MHz	3.2	4.2.1	U	
2	Maximum unwanted emissions within the band 1 625,8 MHz to 1 661,2 MHz and within the band 1 667,3 MHz to 1 675,7 MHz	3.2	4.2.2	U	
3	Processor monitoring	3.2	4.2.3.2	U	
4	Transmit subsystem monitoring	3.2	4.2.3.3	U	
5	Power-on/reset	3.2	4.2.3.4	U	
6	Control Channel (CC) reception	3.2	4.2.3.5	U	
7	Network control commands	3.2	4.2.3.6	U	
8	Initial burst transmission	3.2	4.2.3.7	U	
9	Protection of the radio astronomy service operation in the band 1 660 MHz to 1 660,5 MHz and in the band 1 668,0 MHz to 1 670,0 MHz	3.2	4.2.4	U	
10	Receiver Adjacent Channel Selectivity	3.2	4.2.5	U	
11	Receiver Blocking Characteristics	3.2	4.2.6	U	

### Key to columns:

#### Requirement:

**No** A unique identifier for one row of the table which may be used to identify a requirement.

**Description** A textual reference to the requirement.

#### Essential requirements of Directive

Identification of article(s) defining the requirement in the Directive.

#### Clause(s) of the present document

Identification of clause(s) defining the requirement in the present document unless another document is referenced explicitly.

**Requirement Conditionality:**

<b>U/C</b>	Indicates whether the requirement is unconditionally applicable (U) or is conditional upon the manufacturer's claimed functionality of the equipment (C).
<b>Condition</b>	Explains the conditions when the requirement is or is not applicable for a requirement which is classified "conditional".

Presumption of conformity stays valid only as long as a reference to the present document is maintained in the list published in the Official Journal of the European Union. Users of the present document should consult frequently the latest list published in the Official Journal of the European Union.

Other Union legislation may be applicable to the product(s) falling within the scope of the present document.



---

## Annex B (informative): Maximum Measurement Uncertainty

The measurements described in the present document are based on the following assumptions:

- the measured value related to the corresponding limit is used to decide whether an equipment meets the requirements of the present document;
- the value of the measurement uncertainty for the measurement of each parameter is included in the test report.

Table B.1 shows the recommended values for the maximum measurement uncertainty figures.

**Table B.1: Maximum measurement uncertainty**

<b>Measurement parameter</b>	<b>Uncertainty</b>
Radio Frequency (RF)	$\pm 10$ kHz
RF power	$\pm 0,75$ dB
Conducted spurious	$\pm 4$ dB
Antenna gain	$\pm 2$ dB
Radiated spurious	$\pm 6$ dB

## Annex C (informative): Applicability of parameters given in ETSI EG 203 336

Table C.1 below lists receiver parameters, definitions and technical justification for the absence of certain receiver parameters in the present document vs. those given in ETSI EG 203 336 [i.8].

**Table C.1: Parameters given in ETSI EG 203 336 [i.8]**

Clause in ETSI EG 203 336 [i.8]	Parameter Name	Definition as per the ETSI EG 203 336 [i.8]	Included in the present document?	Technical Justification for absence
5.3.2	Receiver sensitivity	<p>Receiver sensitivity is the ability to receive a wanted signal at low input signal levels while providing a pre-determined level of performance.</p> <p>The guide includes the following points for the inclusion of receiver sensitivity in the present document:</p> <ul style="list-style-type: none"> <li>• Good sensitivity is generally valuable in minimizing interference as it allows the corresponding transmitter power to be lower for a particular link budget.</li> <li>• Knowing the sensitivity of receivers is essential when planning coverage areas for the siting of wide area transmitters, e.g. cellular base stations and broadcast transmitters, or the link budget calculation of fixed links for reaching the expected availability and QoS.</li> </ul>	NO	<p>For radio equipment, including receive only, operating in power limited systems such as satellite systems, it is not viable to lower the satellite transmitter power for these reasons:</p> <ol style="list-style-type: none"> <li>1) Satellites transmit signals from distances as great as 36 000 km, and in order to overcome the huge propagation loss that is inherent, satellites are required to transmit the maximum possible power. Note that space stations are not under RED [i.6].</li> <li>2) Satellite earth stations (terminals) receive and detect very weak signals transmitted by satellites from distances as great as 36 000 km, and in order to close the required link budget, earth station receiver design has to be engineered inherently to be extremely sensitive in order to be able to detect the weak signals, and therefore making receiver sensitivity as a requirement does not achieve anything.</li> </ol> <p>Finally, for systems with fixed transmit power, such satellites at a distance of 36 000 km, having receivers with better sensitivity, does not have an impact on efficient use of spectrum for the avoidance of harmful interference.</p> <p>Because of the above, TC-SES does not believe that sensitivity needs to be included in the present document as in this particular case (satellite earth station ENs), sensitivity does not have an impact on efficient use of spectrum for the avoidance of harmful interference, which is the mandate, of article 3.2 under the RED [i.6].</p>

Clause in ETSI EG 203 336 [i.8]	Parameter Name	Definition as per the ETSI EG 203 336 [i.8]	Included in the present document?	Technical Justification for absence
5.3.3	Receiver co-channel rejection	Receiver co-channel rejection is a measure of the capability of a receiver to receive a wanted signal, without exceeding a given degradation, due to the presence of an unwanted signal, both signals being at the nominal frequency of the receiver.	YES, Included in C, Ku- and Ka-band ENs. NO, not included in ENs covering L- and S-bands.	The primary means to achieve co-channel interference rejection is through the use of directional earth station antennas. For HSs covering earth stations operating on higher bands, such as C-band, Ku-band and Ka-band, these HSs already include receiver co-channel rejection requirement in terms of the earth station's antenna radiation pattern in order to reject the same frequency coming from adjacent satellite. However, for ENs covering earth stations operating in lower bands, such as S-band L-band and lower bands, where they have low gain and Omni-directional antennas, there is no scope for using the antenna to discriminate the interfering signal.
5.3.4	Receiver Selectivity	Receiver selectivity is a measure of the capability to receive a wanted signal, without exceeding a given degradation, due to the presence of an unwanted signal, which differs in frequency from the wanted signal by a specified amount.		This clause does not address particular parameter, see clauses below.
5.3.4.2.1	Receiver adjacent channel selectivity		YES	This is covered by adjacent channel requirements already included in the present document.
5.3.4.4	Receiver spurious response rejection	The spurious response rejection is a measure of the capability of the receiver to receive a wanted signal without exceeding a given degradation due to the presence of an unwanted signal at any frequency at which a response is obtained. The frequencies of the adjacent signals (channels) are excluded. Technical Bodies should specify the frequency range over which this requirement should be evaluated.	This is covered by alternative parameters.	This is covered by receiver blocking and adjacent channel requirements which are already included in the receiver.
5.3.4.3	Receiver blocking	Receiver blocking is a measure of the capability of the receiver to receive a wanted signal without exceeding a given degradation due to the presence of an unwanted input signal at any frequency other than those of the spurious responses or of the adjacent channels.	YES	

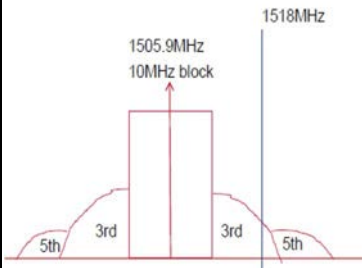
Clause in ETSI EG 203 336 [i.8]	Parameter Name	Definition as per the ETSI EG 203 336 [i.8]	Included in the present document?	Technical Justification for absence
5.3.4.5	Receiver radio-frequency intermodulation	The receiver radio-frequency intermodulation response rejection is a measure of the capability of the receiver to receive a wanted signal, without exceeding a given degradation due to the presence of at least two unwanted signals at frequencies F1 and F2 with a specific frequency relationship to the wanted signal frequency.	This is covered by alternative parameter (receiver blocking).	<p>Historically, it was common to test the receiver blocker performance using a CW signal, where most systems were narrow-band. CW is unmodulated single-tone signal with constant-envelope and is a good approximation for a narrow-band interfering/blocking signal.</p> <p>However, today's systems are generally based on wideband signals like LTE or CDMA; hence CW signal as a blocker is not a representative of real deployed wideband signal systems.</p> <p>Receiver blocking parameter is already included in the relevant HSs but the blocking signal specified in these HSs is not CW, but a wideband signal that reflects a real deployment scenario.</p> <p>As was stated in the above, the blocking signals specified in the HSs are wideband signals. For the purpose of analysing the impact of intermodulation interference on receivers, wideband signals could be thought of as consisting of multiple ideal CW signals.</p> <p>While a CW signal causes blocking by gain compression in the receiver, a wideband signal, like an LTE signal causes gain compression and intermodulation products resulting in spectral re-growth, and these spectral re-growth can be considered as intermodulation products of multiple CW signals, see plot below showing spectral re-growth for a 10 MHz wideband block, 3<sup>rd</sup> and 5<sup>th</sup> order intermodulation products.</p> 

Clause in ETSI EG 203 336 [i.8]	Parameter Name	Definition as per the ETSI EG 203 336 [i.8]	Included in the present document?	Technical Justification for absence
5.3.4.2.2	Receiver adjacent band selectivity	Receiver adjacent band selectivity can be part of multiple signal selectivity because attenuation of the interfering signal will require linear signal processing in the receiver even if the specified interferer is a constant envelope signal.	This is covered by alternative parameters.	This is covered by receiver blocking and adjacent channel requirements already included in the ENs.
5.3.6.1	Receiver dynamic range	Receiver dynamic range is defined as the range of the minimum and maximum input signal levels over which a receiver functions at a specified performance level.	NO	For satellite receivers, front-end dynamic range is irrelevant as the highest signal they receive is very low due to the distance from the satellite.
5.3.6.2	Reciprocal mixing	Reciprocal mixing results from noise sidebands of the Local Oscillator (LO) mixing with unwanted signals producing unwanted noise at the frequency of the receiver which may result in degraded receiver sensitivity.	This is covered by alternative parameters.	The phenomenon of reciprocal mixing is due to the unwanted signals mixing with the LO phase noise and causing receiver degradation, similar to the blocking effect, therefore, TC-SES believes that this case is covered by the receiver blocking requirement already included in the HSs, and there is no technical justification for inclusion in these HSs.
5.3.2.3	Desensitization	Desensitization is a degradation of receiver sensitivity caused by the presence of a large unwanted signal. The term is most commonly applied when an unwanted signal is present in the receiver which is above a receiver's linear "dynamic range" resulting in desensitization, for example by the process of gain compression. It should be noted that gain compression can occur in any stage of the receiver.	This is covered by alternative parameters.	This is an effect of interference and not a cause and is therefore already covered by blocking, see above explanation about blocking and receiver radio-frequency intermodulation.
5.3.5	Receiver unwanted emissions in the spurious domain	This is the limit for unwanted emissions in the spurious domain referenced at the antenna port.	This is covered by the equipment's unwanted emission requirements.	The unwanted emission requirement from the receiver in the spurious domain is already included in the unwanted emission requirements of the equipment.

---

## Annex D (informative): Bibliography

- CENELEC EN 55022: "Limits and methods of measurement of radio disturbance characteristics of information technology equipment".
- ETSI ETS 300 831: "Electromagnetic compatibility and Radio spectrum Matters (ERM); ElectroMagnetic Compatibility (EMC) for Mobile Earth Stations (MES) used within Satellite Personal Communications Networks (S-PCN) operating in the 1,6/2,4 GHz and 2 GHz frequency bands".
- ETSI ETS 300 423: "Satellite Earth Stations and Systems (SES); Land Mobile Earth Stations (LMES) operating in the 1,5/1,6 GHz bands providing voice and/or data communications".
- Directive 1999/5/EC of the European Parliament and of the Council of 9 March 1999 on radio equipment and telecommunications equipment and the mutual recognition of their conformity (R&TTE Directive).
- ETSI TBR 044 (edition 1) (05-1998): "Satellite Earth Stations and Systems (SES); Land Mobile Earth Stations (LMES) operating in the 1,5 GHz and 1,6 GHz bands providing voice and/or data communications".
- Directive 98/34/EC of the European Parliament and of the Council of 22 June 1998 laying down a procedure for the provision of information in the field of technical standards and regulations and of rules on Information Society services.
- Directive 98/48/EC of the European Parliament and of the Council of 20 July 1998 amending Directive 98/34/EC laying down a procedure for the provision of information in the field of technical standards and regulations.
- CEPT/ERC/REC 74-01: "Unwanted emissions in the spurious domain".

---

## History

<b>Document history</b>		
V1.1.1	May 2000	Publication
V1.2.1	January 2012	Publication
V1.2.2	June 2013	Publication
V2.1.2	November 2016	Publication
V2.2.0	September 2020	EN Approval Procedure AP 20201208: 2020-09-09 to 2020-12-08