

Draft ETSI EN 301 428 V1.1.1 (1999-12)

Candidate Harmonized European Standard (Telecommunications series)

**Satellite Earth Stations and Systems (SES);
Harmonized EN for Very Small Aperture Terminal (VSAT);
Transmit-only, transmit/receive or receive-only
satellite earth stations operating
in the 11/12/14 GHz frequency bands
covering essential requirements under
article 3.2 of the R&TTE directive**



Reference

DEN/SES-000-TBR28

Keywords

satellite, VSAT, regulation

ETSI

Postal address

F-06921 Sophia Antipolis Cedex - FRANCE

Office address

650 Route des Lucioles - Sophia Antipolis
Valbonne - FRANCE
Tel.: +33 4 92 94 42 00 Fax: +33 4 93 65 47 16
Siret N° 348 623 562 00017 - NAF 742 C
Association à but non lucratif enregistrée à la
Sous-Préfecture de Grasse (06) N° 7803/88

Internet

secretariat@etsi.fr
Individual copies of this ETSI deliverable
can be downloaded from
<http://www.etsi.org>
If you find errors in the present document, send your
comment to: editor@etsi.fr

Important notice

This ETSI deliverable may be made available in more than one electronic version or in print. In any case of existing or perceived difference in contents between such versions, the reference version is the Portable Document Format (PDF). In case of dispute, the reference shall be the printing on ETSI printers of the PDF version kept on a specific network drive within ETSI Secretariat.

Copyright Notification

No part may be reproduced except as authorized by written permission.
The copyright and the foregoing restriction extend to reproduction in all media.

© European Telecommunications Standards Institute 1999.
All rights reserved.

Contents

Intellectual Property Rights	6
Foreword.....	6
Introduction	7
1 Scope	9
2 References	10
3 Definitions and abbreviations	10
3.1 Definitions	10
3.2 Abbreviations	12
4 Technical requirements specifications	12
4.1 Environmental profile.....	12
4.2 Conformance requirements.....	12
4.2.1 Off-axis spurious radiation.....	12
4.2.1.1 Justification	12
4.2.1.2 Specification.....	13
4.2.1.2.1 Transmit VSAT	13
4.2.1.2.2 Receive-only VSAT.....	14
4.2.1.3 Conformance tests	14
4.2.2 On-axis spurious radiation for transmit VSAT	14
4.2.2.1 Justification	14
4.2.2.2 Specification.....	14
4.2.2.2.1 Carrier-on state	14
4.2.2.2.2 Carrier-off state and transmission disabled state	15
4.2.2.3 Conformance tests	15
4.2.3 Off-axis EIRP emission density within the band.....	15
4.2.3.1 Justification	15
4.2.3.2 Specification.....	15
4.2.3.3 Conformance tests	16
4.2.4 Carrier suppression	16
4.2.4.1 Justification	16
4.2.4.2 Specification.....	16
4.2.4.3 Conformance tests	16
4.2.5 Mechanical (antenna pointing) for transmit VSAT.....	16
4.2.5.1 Justification	16
4.2.5.2 Specification.....	16
4.2.5.3 Conformance tests	16
4.2.6 Control and monitoring for transmit VSAT	17
4.2.6.1 Control and Monitoring Functions (CMF)	17
4.2.6.1.1 General	17
4.2.6.1.2 CMF state transition diagram	17
4.2.6.1.3 Specification of states.....	18
4.2.6.2 Control Channels (CC).....	19
4.2.6.2.1 Justification.....	19
4.2.6.2.2 Specification	19
4.2.6.2.3 Conformance tests	19
4.2.6.3 Self monitoring functions	20
4.2.6.3.1 General	20
4.2.6.3.2 Processor monitoring.....	20
4.2.6.3.2.1 Justification	20
4.2.6.3.2.2 Specification	20
4.2.6.3.2.3 Conformance tests.....	20
4.2.6.3.3 Transmit subsystem monitoring.....	20
4.2.6.3.3.1 Justification.....	20

4.2.6.3.3.2	Specification	20
4.2.6.3.3.3	Conformance tests.....	20
4.2.6.3.4	VSAT transmission validation.....	21
4.2.6.3.4.1	General.....	21
4.2.6.3.4.2	VSAT transmission validation by the CCMF.....	21
4.2.6.3.4.2.1	Justification	21
4.2.6.3.4.2.2	Specification.....	21
4.2.6.3.4.2.3	Conformance tests	21
4.2.6.3.4.3	VSAT transmission validation by receiving station(s).....	21
4.2.6.3.4.3.1	Justification	21
4.2.6.3.4.3.2	Specification.....	21
4.2.6.3.4.3.3	Conformance tests	21
4.2.6.3.4.4	Transmission validation for VSAT using external CC.....	22
4.2.6.3.4.4.1	Purpose.....	22
4.2.6.3.4.4.2	Specification.....	22
4.2.6.3.4.4.3	Conformance tests	22
4.2.6.4	Reception of commands from the CCMF.....	22
4.2.6.4.1	General	22
4.2.6.4.2	Disable message	22
4.2.6.4.2.1	Justification.....	22
4.2.6.4.2.2	Specification	22
4.2.6.4.2.3	Conformance tests.....	22
4.2.6.4.3	Enable Message.....	22
4.2.6.4.3.1	Justification.....	22
4.2.6.4.3.2	Specification	22
4.2.6.4.3.3	Conformance tests.....	22
4.2.6.5	Power-on/Reset	23
4.2.6.5.1	Justification.....	23
4.2.6.5.2	Specification.....	23
4.2.6.5.3	Conformance tests	23
5	Testing for compliance with technical requirements	23
5.1	Environmental conditions for testing.....	23
5.2	Essential radio test suites.....	23
6	Test methods for the complete VSAT.....	23
6.1	General	23
6.2	Off-axis spurious radiation	24
6.2.1	Test method	24
6.2.1.1	General.....	24
6.2.1.2	Up to 1 000 MHz	25
6.2.1.2.1	Test site.....	25
6.2.1.2.2	Measuring receivers.....	25
6.2.1.2.3	Procedure.....	25
6.2.1.3	Above 1 000 MHz.....	26
6.2.1.3.1	General	26
6.2.1.3.2	Identification of the significant frequencies of spurious radiation	26
6.2.1.3.2.1	Test site	26
6.2.1.3.2.2	Procedure	26
6.2.1.3.3	Measurement of radiated power levels of identified spurious radiation	26
6.2.1.3.3.1	Test site	26
6.2.1.3.3.2	Procedure	27
6.2.1.3.4	Measurement of conducted spurious radiation at the antenna flange.....	28
6.2.1.3.4.1	Test site	28
6.2.1.3.4.2	Procedure	28
6.3	On-axis spurious radiation.....	28
6.3.1	Test method	28
6.3.1.1	Test site	28
6.3.1.2	Method of measurement.....	29
6.3.1.2.1	General	29
6.3.1.2.2	Method of measurement at the antenna flange.....	29

6.3.1.2.3	Method of measurement with a test antenna	30
6.4	Off-axis EIRP emission density within the band	31
6.4.1	Test method	31
6.4.1.1	General	31
6.4.1.2	Transmit output power density	31
6.4.1.2.1	General	31
6.4.1.2.2	Test site.....	31
6.4.1.2.3	Method of measurement	31
6.4.1.3	Antenna transmit gain.....	32
6.4.1.3.1	General	32
6.4.1.3.2	Test site.....	32
6.4.1.3.3	Method of measurement	32
6.4.1.4	Antenna transmit radiation patterns	33
6.4.1.4.1	General	33
6.4.1.4.2	Test site.....	33
6.4.1.4.3	Test arrangement	33
6.4.1.4.4	Co-polar radiation pattern - azimuth.....	34
6.4.1.4.5	Co-polar radiation pattern - elevation	34
6.4.1.4.6	Cross-polar radiation pattern - azimuth	35
6.4.1.4.7	Cross-polar radiation pattern - elevation.....	35
6.4.2	Computation of results	36
6.5	Carrier suppression.....	36
6.5.1	Test method	36
6.6	Antenna pointing for transmit VSAT	36
6.6.1	Test method	36
6.7	Control and monitoring for transmit VSAT.....	37
6.7.1	General.....	37
6.7.2	Test arrangement.....	37
6.7.3	Control Channels (CC)	38
6.7.3.1	Test method.....	38
6.7.3.1.1	Test method for internal CC	38
6.7.3.1.2	Test method for external CC.....	38
6.7.4	Processor monitoring	39
6.7.4.1	Test method.....	39
6.7.5	Transmit subsystem monitoring	39
6.7.5.1	Test method.....	39
6.7.6	VSAT transmission validation	39
6.7.6.1	Test method for VSAT validation by the CCMF for VSAT using internal CC.....	39
6.7.6.2	Test method for VSAT validation by receiving station(s) for VSAT using internal CC	39
6.7.6.3	Test method for transmission validation for VSAT using external CC	39
6.7.7	Reception of commands from the CCMF	40
6.7.7.1	Test method.....	40
6.7.8	Power-on/Reset.....	40
6.7.8.1	Test method.....	40
7	Test methods for modified VSAT	41
7.1	General	41
7.2	Antenna subsystem replacement.....	41
Annex A (normative):	The EN Requirements Table (EN-RT)	42
Annex B (informative):	Pointing stability methodology	43
Bibliography		44
History		45

Intellectual Property Rights

IPRs essential or potentially essential to the present document may have been declared to ETSI. The information pertaining to these essential IPRs, if any, is publicly available for **ETSI members and non-members**, and can be found in SR 000 314: "*Intellectual Property Rights (IPRs); Essential, or potentially Essential, IPRs notified to ETSI in respect of ETSI standards*", which is available from the ETSI Secretariat. Latest updates are available on the ETSI Web server (<http://www.etsi.org/ipr>).

Pursuant to the ETSI IPR Policy, no investigation, including IPR searches, has been carried out by ETSI. No guarantee can be given as to the existence of other IPRs not referenced in SR 000 314 (or the updates on the ETSI Web server) which are, or may be, or may become, essential to the present document.

Foreword

This Candidate Harmonized European Standard (Telecommunications series) has been produced by ETSI Technical Committee Satellite Earth Stations and Systems (SES), and is now submitted for the ETSI standards One-step Approval Procedure.

The present document has been produced by ETSI in response to a mandate from the European Commission issued under Council Directive 98/34/EC [3] (as amended) laying down a procedure for the provision of information in the field of technical standards and regulations.

The present document is intended to become a Harmonized Standard, the reference of which will be published in the Official Journal of the European Communities referencing the Directive 1999/5/EC [1] of the European Parliament and of the Council of 9 March 1999 on radio equipment and telecommunications terminal equipment and the mutual recognition of their conformity ("the R&TTE Directive").

Proposed national transposition dates	
Date of latest announcement of this EN (doa):	3 months after ETSI publication
Date of latest publication of new National Standard or endorsement of this EN (dop/e):	6 months after doa
Date of withdrawal of any conflicting National Standard (dow):	6 months after doa

Introduction

ETSI has designed a modular structure for the standards. Each standard is a module in the structure. The modular structure is shown in figure 1.

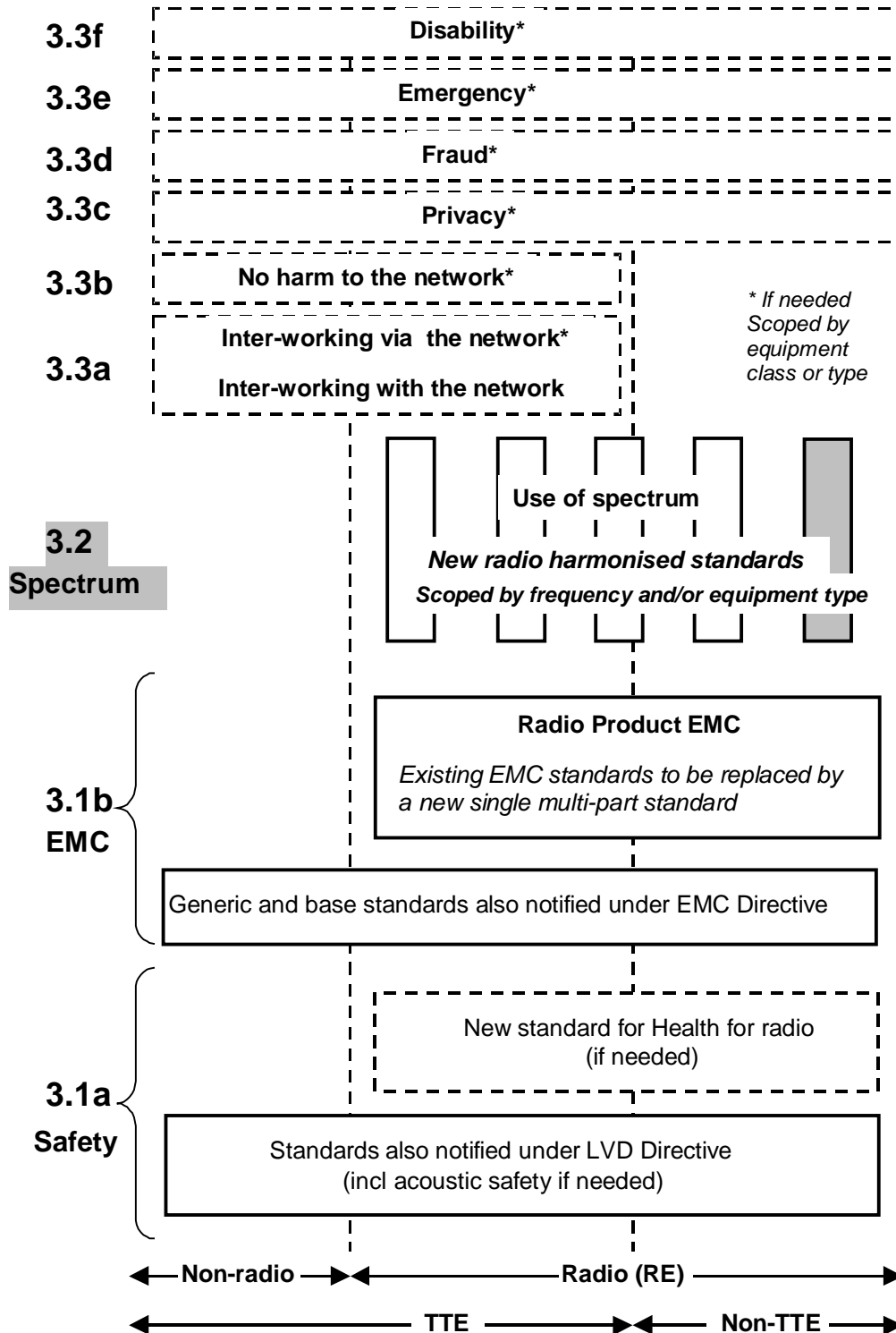

Figure 1: Modular structure for the various standards used under the R&TTE Directive

The left hand edge of the figure shows the different subclauses of Article 3 of the Directive.

For article 3.3 various horizontal boxes are shown. Their dotted lines indicate that no essential requirements in these areas have yet been adopted by the Commission. If such essential requirements are adopted, they will be elaborated in individual standards whose scope is likely to be specified by function or interface type.

The vertical boxes show the standards under article 3.2 for the use of the radio spectrum. The scopes of these standards are specified either by frequency (normally in the case where frequency bands are harmonized) or by radio equipment type.

For article 3.1(b), the diagram shows the new single multi-part product EMC standard for radio, and the existing collection of generic and base standards currently used under the EMC Directive. The parts of this new standard will become available in the second half of 2 000, and the existing separate EMC standards will be used until it is available.

For article 3.1(a) the diagram shows the existing safety standards currently used under the LVD Directive and the possibility of a new standard on health relating to radio emissions

The bottom of the figure shows the relationship of the standards to radio equipment and telecommunications terminal equipment. A particular equipment may be radio equipment, telecommunications terminal equipment or both.

The modular approach has been taken because:

- it minimizes the number of standards needed. Because equipment may have multiple interfaces and functions it is not practicable to produce a single standard for each possible combination of functions that may occur in an equipment.
- it provides scope for standards to be added:
 - under article 3.2 when new frequency bands are agreed; or
 - under article 3.3 should the Commission take the necessary decisions;without requiring alteration of standards that are already published.

The present document is based on TBR 028 [4].

The determination of the parameters of the user earth stations using a given geo-stationary satellite for the protection of the spectrum allocated to that satellite, is considered to be under the responsibility of the satellite operator or the satellite network operators. For this reason the requirement on the cross polarization discrimination which was in TBR 28 [4] has not been copied in the present document and inter-modulation limits inside the band 14,0 GHz to 14,5 GHz are to be determined by system design and are subject to satellite operator specifications.

The requirements have been selected to ensure an adequate level of compatibility with other radio services. The levels, however, do not cover extreme cases which may occur in any location but with a low probability of occurrence.

The present document may not cover those cases where a potential source of interference which is producing individually repeated transient phenomena or a continuous phenomenon is present, e.g. a radar or broadcast site in the near vicinity. In such a case it may be necessary to use special protection applied to either the source of interference, or the interfered part or both.

The present document does not contain any requirement, recommendation or information about the installation of the VSAT.

1 Scope

The present document applies to Very Small Aperture Terminals (VSATs) which have the following characteristics:

- the VSAT are operating in one or more frequency ranges in the part of the following bands allocated exclusively to the Fixed Satellite Services (FSS):
 - 14,00 GHz to 14,25 GHz (earth-to-space);
 - 12,50 GHz to 12,75 GHz (space-to-earth);or in the shared parts of the following bands, allocated to the FSS and Fixed Services (FS):
 - 14,25 GHz to 14,50 GHz (earth-to-space);
 - 10,70 GHz to 11,70 GHz (space-to-earth).
- the VSAT use linear polarization.
- the VSAT operate through a geostationary satellite at least 3° away from any other geostationary satellite operating in the same frequency band and covering the same area.
- the VSAT antenna diameter does not exceed 3,8 m, or equivalent corresponding aperture.
- the VSAT are either:
 - transmit only VSAT: designed for transmission only of radio-communications signals in any of the frequency bands (earth-space) specified above; or
 - transmit and receive VSAT: designed for transmission and reception of radio-communications signals in any of the frequency bands specified above; or
 - receive only VSAT: designed for reception only of radio-communications signals in any of the frequency bands (space-earth) specified above.
- the VSAT are designed usually for unattended operation.
- the VSAT are operating as part of a satellite network (e.g. star, mesh or point-to-point) used for the distribution and/or exchange of information between users.
- the VSAT are controlled and monitored by a Centralized Control and Monitoring Function (CCMF). The CCMF is outside the scope of the present document.

The present document applies to the VSAT with its ancillary equipment and its various terrestrial ports, and when operated within the boundary limits of the operational environmental profile declared by the applicant.

The present document is intended to cover the provisions of Directive 1999/5/EC [1] (R&TTE Directive) Article 3.2, which states that "... radio equipment shall be so constructed that it effectively uses the spectrum allocated to terrestrial/space radio communications and orbital resources so as to avoid harmful interference".

In addition to the present document, other ENs that specifies technical requirements in respect of essential requirements under other parts of Article 3 of the R&TTE Directive [1] may apply to equipment within the scope of the present document.

NOTE: A list of such ENs is included on the ETSI web site.

2 References

The following documents contain provisions which, through reference in this text, constitute provisions of the present document.

- References are either specific (identified by date of publication, edition number, version number, etc.) or non-specific.
- For a specific reference, subsequent revisions do not apply.
- For a non-specific reference, the latest version applies.
- A non-specific reference to an ETS shall also be taken to refer to later versions published as an EN with the same number.

- [1] Directive 1999/5/EC of the European Parliament and of the Council of 9 March 1999 on radio equipment and telecommunications equipment and the mutual recognition of their conformity.
- [2] CISPR 16-1: "Specification for radio disturbance and immunity measuring apparatus and methods - Part 1: Radio disturbance and immunity measuring apparatus" (annex G: Validation of the open area test site for the frequency range of 30 MHz to 1 000 MHz).
- [3] Directive 98/34/EC of the European Parliament and of the Council of 22 June 1998 laying down a procedure for the provision of information in the field of technical standards and regulations.
- [4] TBR 028: "Satellite Earth Stations and Systems (SES); Very Small Aperture Terminal (VSAT); Transmit-only, transmit/receive or receive-only satellite earth stations operating in the 11/12/14 GHz frequency bands".

3 Definitions and abbreviations

3.1 Definitions

For the purpose of the present document, the terms and definitions given in the R&TTE Directive [1], and the following terms and definitions apply.

ancillary equipment: equipment used in connection with a VSAT is considered as ancillary if the three following conditions are met:

- a) the equipment is intended for use in conjunction with the VSAT to provide additional operational and/or control features (e.g. to extend control to another position or location); and
- b) the equipment cannot be used on a stand alone basis, to provide user functions independently of the VSAT; and
- c) the absence of the equipment does not inhibit the operation of the VSAT.

applicant: manufacturer or his authorized representative within the European Community or the person responsible for placing the apparatus on the market.

carrier-off state: VSAT is in this state when it is authorized by the Centralized Control and Monitoring Functions (CCMF) to transmit, but when it does not transmit any signal.

NOTE 1: The existence of a carrier-off state depends on the system of transmission used. For VSAT designed for continuous transmission mode there may be no carrier-off state.

carrier-on state: VSAT is in this state when it is authorized by the CCMF to transmit and when it transmits a signal.

Centralized Control and Monitoring Functions (CCMF): set of functional entities that, at system level, monitor and control the correct operation of all transmit VSAT in a network.

Control Channel (CC): channel or channels by which VSAT receive control information from the CCMF.

Environmental profile: range of environmental conditions under which equipment within the scope of the present document is required to comply with the provisions of the present document.

external control channel: control channel which is either (i) carried by the VSAT network via the same or another satellite, but not within the internal protocol of the VSAT system, or (ii) carried by the PSTN or some other means.

external response channel: response channel which is either (i) carried by the VSAT network via the same or another satellite, but not within the internal protocol of the VSAT system, or (ii) carried by the PSTN or some other means.

indoor unit: is composed of that part of the VSAT which is not part of the outdoor unit. It is generally installed inside a building and is connected to the outdoor unit. The connection cable between the outdoor and indoor unit is considered part of the indoor unit.

integral antenna: antenna which may not be removed during the tests according to the applicant's statement.

internal control channel: control channel which is carried by the VSAT network via the same satellite as used for transmission of user data and within the internal protocol structure of the VSAT system.

internal response channel: response channel which is carried by the VSAT network via the same satellite as used for transmission of user data and within the internal protocol structure of the VSAT system.

network: in the present document a network is any network configuration including star, mesh and point-to-point configurations.

nominated bandwidth: bandwidth of the VSAT radio frequency transmission is nominated by the applicant. The nominated bandwidth is centred on the transmit frequency and does not exceed 5 times the occupied bandwidth.

NOTE 2: The nominated bandwidth is wide enough to encompass all spectral elements of the transmission which have a level greater than the specified spurious radiation limits. The nominated bandwidth is wide enough to take account of the transmit carrier frequency stability. This definition is chosen to allow flexibility regarding adjacent channel interference levels which will be taken into account by operational procedures depending on the exact transponder carrier assignment situation.

occupied Bandwidth (Bo): for a digital modulation scheme - the width of the signal spectrum 10 dB below the maximum inband density. For an analogue modulation scheme - the width of a frequency band such that, below the lower and above the upper frequency limits, the mean power emitted is equal to 0,5 % of the total mean power of the emission.

outdoor unit: part of the VSAT intended to be installed outdoor, as declared by the applicant, or as indicated in the user documentation.

The outdoor unit usually comprises three main parts:

- a) the antenna sub-system which converts the incident radiation field into a guided wave and vice versa;
- b) the Low Noise Block (LNB) down converter, which is a device that amplifies, with very low internal noise, the received signals in the Radio Frequency (RF) band and converts them to intermediate frequencies;
- c) the upconverter and the power amplifier which convert from the intermediate frequency to RF and amplify the low level RF signals for transmission through the antenna subsystem.

NOTE 3: The installation equipment (means of attachment) is outside the scope of the present document. However, the antenna structures and other components directly mounted on the antenna and forming an integral part of it, are subject to the specifications of the present document.

removable antenna: antenna which may be removed during the tests according to the applicant's statement.

Response Channel (RC): channel by which VSAT transmit monitoring information to the CCMF.

spurious radiation: any radiation outside the nominated bandwidth.

NOTE 4: For a receive-only VSAT there is no nominated bandwidth therefore any radiation is a spurious radiation.

transmission disabled state: VSAT is in this state when it is not authorized by the CCMF to transmit.

transmit VSAT: VSAT capable of being used either for transmission only, or for transmission and reception.

3.2 Abbreviations

For the purpose of the present document, the following abbreviations apply:

CC	Control Channel
CCD	Central Control Disable
CCE	Central Control Enable
CCMF	Centralized Control and Monitoring Functions
CMF	Control and Monitoring Functions
CV	Control Variable
EIRP	Equivalent Isotropically Radiated Power
EN	European Standard
EUT	Equipment Under Test
FS	Fixed Service
FSS	Fixed Satellite Service
HPA	High Power Amplifier
ITU	International Telecommunications Union
LNA	Low Noise Amplifier
LNB	Low Noise Block
modem	MOdulator/DEModulator
PSTN	Public Switched Telephone Network
R&TTE	Radio and Telecommunications Terminal Equipment
RC	Response Channel
RE	Reset Event
RF	Radio Frequency
SMF	Status Monitoring Fail
SMP	Status Monitoring Pass
SMV	Self Monitoring Variable
STE	Special Test Equipment
VSAT	Very Small Aperture Terminal

4 Technical requirements specifications

4.1 Environmental profile

The technical requirements of the present document apply under the environmental profile for operation of the equipment, which shall be declared by the applicant. The equipment shall comply with all the technical requirements of the present document at all times when operating within the boundary limits of the declared operational environmental profile.

The environmental profile for operation of the equipment shall include the ranges of humidity, temperature and supply voltage.

4.2 Conformance requirements

4.2.1 Off-axis spurious radiation

4.2.1.1 Justification

To limit the level of interference to terrestrial and satellite radio services.

4.2.1.2 Specification

4.2.1.2.1 Transmit VSAT

- 1) The VSAT shall not exceed the limits for radiated interference field strength over the frequency range from 30 MHz to 1 000 MHz specified in table 1.

Table 1: Limits of radiated field strength at a test distance of 10 m in a 120 kHz bandwidth

Frequency range (MHz)	Quasi-peak limits (dB μ V/m)
30 to 230	30
230 to 1 000	37

The lower limits shall apply at the transition frequency.

- 2) When the VSAT is in the transmission disabled state, the off-axis spurious Equivalent Isotropically Radiated Power (EIRP) from the VSAT, in any 100 kHz band, shall not exceed the limits in table 2, for all off-axis angles greater than 7°:

Table 2: Limits of spurious EIRP - transmission disabled state

Frequency band	EIRP limit (dBpW)
1,0 GHz to 10,7 GHz	48
10,7 GHz to 21,2 GHz	54
21,2 GHz to 40,0 GHz	60

The lower limits shall apply at the transition frequency.

- 3) This specification applies outside the nominated bandwidth. For both the carrier-on and carrier-off states, the off-axis spurious EIRP in any 100 kHz band from the VSAT, shall not exceed the limits in table 3, for all off-axis angles greater than 7°:

Table 3: Limits of spurious EIRP

Frequency band	EIRP limit (dBpW)
1,0 GHz to 3,4 GHz	49
3,4 GHz to 10,7 GHz	55
10,7 GHz to 13,85 GHz	61
13,85 GHz to 14,0 GHz	75 (see note)
14,25 GHz to 14,65 GHz	75 (see note)
14,65 GHz to 21,2 GHz	61
21,2 GHz to 40,0 GHz	67
NOTE: This limit may be exceeded in a frequency band which shall not exceed 50 MHz, centred on the carrier frequency, provided that the on-axis EIRP density at the considered frequency is 50 dB below the maximum on-axis EIRP density of the signal (within the nominated bandwidth) expressed in dBW/100 kHz.	

The lower limits shall apply at the transition frequency.

In the frequency band 28,0 to 29,0 GHz, for any 20 MHz band within which one or more spurious signals exceeding the above limit of 67 dBpW are present, then the power of each of those spurious signals exceeding the limit shall be added in watts, and the sum shall not exceed 78 dBpW.

For VSAT designed to transmit simultaneously several different carriers (multicarrier operation), the above limits apply to each individual carrier when transmitted alone.

- 4) These limits are applicable to the complete VSAT equipment, comprising of the indoor and outdoor units with at least 10 m of cable connecting them.

4.2.1.2.2 Receive-only VSAT

- 1) The VSAT shall not exceed the limits for radiated interference field strength specified in table 4 over the frequency range from 30 MHz to 1 000 MHz.

Table 4: Limits of radiated field strength at a test distance of 10 m in a 120 kHz bandwidth

Frequency range (MHz)	Quasi-peak limits (dB μ V/m)
30 to 230	30
230 to 1 000	37

The lower limits shall apply at the transition frequency.

- 2) The off-axis spurious EIRP from the VSAT, in any 100 kHz band, shall not exceed the limits in table 5, for all off-axis angles greater than 7°:

Table 5: Limits of spurious EIRP

Frequency band	EIRP limit (dBpW)
1 GHz to 10,7 GHz	48
10,7 GHz to 21,2 GHz	54
21,2 GHz to 40,0 GHz	60

The lower limits shall apply at the transition frequency.

- 3) These limits are applicable to the complete VSAT equipment, comprising of the indoor and outdoor units with at least 10 m of cable connecting them.

4.2.1.3 Conformance tests

Conformance tests shall be carried out in accordance with subclause 6.2.

4.2.2 On-axis spurious radiation for transmit VSAT

4.2.2.1 Justification

To limit the level of interference to satellite radio services.

4.2.2.2 Specification

4.2.2.2.1 Carrier-on state

In the 14,0 GHz to 14,5 GHz band the EIRP spectral density of the spurious radiation and outside the nominated bandwidth shall not exceed $4 - 10 \log N$ dBW in any 100 kHz band.

In a bandwidth of 5 times the occupied bandwidth centred on the carrier centre frequency, the EIRP spectral density of the spurious radiation outside the nominated bandwidth, shall not exceed $18 - 10 \log N$ dBW in any 100 kHz band.

N is the maximum number of VSAT which are expected to transmit simultaneously in the same carrier frequency band. This number shall not be exceeded for more than 0,01 % of the time. The value of N and the operational conditions of the system shall be declared by the applicant.

NOTE 1: The on-axis spurious radiations, outside the 14,0 GHz to 14,5 GHz band, are indirectly limited by subclause 4.2.1.2.1. Consequently no specification is needed.

NOTE 2: Intermodulation limits inside the band 14,0 GHz to 14,5 GHz are to be determined by system design and are subject to satellite operator specifications.

For VSAT designed to transmit simultaneously several different carriers (multicarrier operation), the above limits only apply to each individual carrier when transmitted alone.

4.2.2.2.2 Carrier-off state and transmission disabled state

In the 14,0 GHz to 14,5 GHz band the EIRP spectral density of the spurious radiation outside the nominated bandwidth shall not exceed -21 dBW in any 100 kHz band.

4.2.2.3 Conformance tests

Conformance tests shall be carried out in accordance with subclause 6.3.

4.2.3 Off-axis EIRP emission density within the band

Off-axis EIRP emission density (co-polar and cross-polar) within the band 14,0 GHz to 14,5 GHz.

4.2.3.1 Justification

Protection of other satellite (uplink) systems.

4.2.3.2 Specification

The maximum EIRP in any 40 kHz band within the nominated bandwidth of the co-polarized component in any direction ϕ degrees from the antenna main beam axis shall not exceed the following limits:

$$\begin{array}{llll}
 \mathbf{33 - 25 \log \phi - 10 \log N \text{ dBW}} & \mathbf{for} & \mathbf{2,5^\circ \leq \phi \leq 7,0^\circ;} \\
 +12 - 10 \log N \text{ dBW} & \mathbf{for} & 7,0^\circ < \phi \leq 9,2^\circ; \\
 36 - 25 \log \phi - 10 \log N \text{ dBW} & \mathbf{for} & 9,2^\circ < \phi \leq 48^\circ; \\
 - 6 - 10 \log N \text{ dBW} & \mathbf{for} & \phi > 48^\circ.
 \end{array}$$

Where ϕ is the angle, in degrees, between the main beam axis and the direction considered, and N is the maximum number of VSAT which may transmit simultaneously in the same carrier frequency band. This number shall be declared by the applicant.

For $\phi > 70^\circ$ the values given above may be increased to $4 - 10 \log N$ dBW over the range of angles for which the particular feed system may give rise to relatively high levels of spillover.

For antennas designed for minimum off-axis gain in the direction of the geostationary orbit, the specification for ϕ between $2,5^\circ$ and 20° need only be met within $\pm 3^\circ$ of a plane bisected by the main beam axis. This plane shall be marked and identified on the antenna in order to be able to align it tangentially to the geostationary orbit. There shall be an axis of rotation along or parallel to the main beam axis, with adjustment capability to an accuracy of $0,5^\circ$. The antenna shall be capable of having the above plane aligned with the geostationary orbit plane.

In addition the maximum EIRP in any 40 kHz band within the nominated bandwidth of the cross-polarized component in any direction ϕ degrees from the antenna main beam axis shall not exceed the following limits:

$$\begin{array}{llll}
 23 - 25 \log \phi - 10 \log N \text{ dBW} & \mathbf{for} & 2,5^\circ \leq \phi \leq 7,0^\circ; \\
 +2 - 10 \log N \text{ dBW} & \mathbf{for} & 7,0^\circ < \phi \leq 9,2^\circ.
 \end{array}$$

Where ϕ is the angle, in degrees, between the main beam axis and the direction considered, and N is the maximum number of VSAT which may transmit simultaneously in the same carrier frequency band. This number shall be declared by the applicant.

4.2.3.3 Conformance tests

Conformance tests shall be carried out in accordance with subclause 6.4.1 with the results being computed in accordance with subclause 6.4.2.

4.2.4 Carrier suppression

4.2.4.1 Justification

To allow for the satisfactory suppression of transmissions of a VSAT by the CCMF.

4.2.4.2 Specification

When the VSAT carrier is suppressed the VSAT shall be in the transmission disabled state and the EIRP density shall not exceed 4 dBW in any 4 kHz band within the nominated bandwidth.

4.2.4.3 Conformance tests

Conformance tests shall be carried out in accordance with subclause 6.5.

4.2.5 Mechanical (antenna pointing) for transmit VSAT

4.2.5.1 Justification

Protection of signals to and from both the same and adjacent satellites.

4.2.5.2 Specification

a) Pointing stability:

Under the condition of 100 km/h maximum wind speed, with gusts of 130 km/h lasting 3 seconds, the installation shall not show any sign of permanent distortion and shall not need repointing after the application of the wind load.

b) Pointing accuracy capability:

Specification 1: Main beam pointing accuracy

The antenna mount shall allow the position of the antenna transmit main beam axis to be maintained with an accuracy better than the off-axis angle measured when the main beam gain has decreased by 1 dB at any frequency in the equipment operating band, over the full range of azimuth and elevation movement available to the antenna.

Specification 2: Non-symmetrical main beam orientation

This specification applies to antennas designed for minimum off-axis gain in the direction of the geostationary orbit (e.g. elliptical antennas). The plane bisected by the main beam axis and where the off-axis is minimum shall be marked on the antenna. There shall be an axis of rotation along or parallel to the main beam axis, with adjustment capability to an accuracy of 0,5°. The antenna shall be capable of having the above plane aligned with the geostationary orbit plane.

c) Polarization angle alignment capability:

The polarization angle shall be continuously adjustable in a range of at least 180°;

it shall be possible to fix the transmit antenna polarization angle with an accuracy of at least 1°.

4.2.5.3 Conformance tests

Conformance tests shall be carried out in accordance with subclause 6.6.

4.2.6 Control and monitoring for transmit VSAT

4.2.6.1 Control and Monitoring Functions (CMF)

4.2.6.1.1 General

The following minimum set of control and monitoring functions shall be implemented in VSAT in order to minimize the probability that they may originate transmissions that may interfere with other systems.

Under any fault condition when the VSAT transmissions are being suppressed the EIRP density shall not exceed the limits for the transmission disabled state specified in subclauses 4.2.1, 4.2.2 and 4.2.4.

4.2.6.1.2 CMF state transition diagram

A VSAT shall implement two sets of control and monitoring functions:

- a) Monitoring functions: these functions encompass all the checks and verifications that the VSAT shall perform in order to identify any anomalous situation which may cause impairments to other systems.

The overall result of these checks and verifications are contained in a functional variable named Self Monitoring Variable (SMV). The states of this variable are "Pass" and "Fail".

The state of the SMV may change as a result of events. These are:

- Status Monitoring Pass event (SMP);
- Status Monitoring Fail event (SMF).

The circumstances under which these events may take place are specified in subclause 4.2.6.3 of the present document.

- b) Control functions: these functions are associated with the ability of the CCMF to inhibit and to permit transmissions from an individual VSAT.

These functions are reflected in the state of a functional variable, resident at each VSAT, named Control Variable (CV). The states of this variable are "enable" and "disable".

The CV may change as a result of events. These are:

- Central Control Disable (CCD);
- Central Control Enable (CCE).

The circumstances associated to the reception of the messages resulting in these events are specified in subclause 4.2.6.4 of the present document.

Besides these two sets of control and monitoring functions, the VSAT shall achieve a controlled non-transmitting state following actuation of the terminal (power-on).

VSAT that allow local operator intervention may include a terminal reset function which when actuated results in a Reset Event (RE).

Subclause 4.2.6.5 specifies the functions associated with the occurrence of the "power-on" and REs.

The combination of the SMV and CV results in the definition of 4 possible states in which a VSAT may be from the control and monitoring point-of-view.

The states of the VSAT are:

- out-of-service;
- checking;
- stand-by;

- in-service.

Figure 2 shows the state transition diagram associated with these 4 states. The operational behaviour of the VSAT (with respect to control and monitoring), in each of these states, is specified in subclause 4.2.6.1.3.

In the "in-service" state, the SMF and CCD events may be processed as the RE, in order to set the VSAT in the "out-of-service" state.

In the "out-of-service" state the first or all CCE events may be ignored.

When the VSAT transmits several carriers having different frequencies, a VSAT state machine as described above may be associated with each carrier or each set of carriers. The events then apply to the subsystem associated with the specific carrier or the specific set of carriers, rather than the whole VSAT.

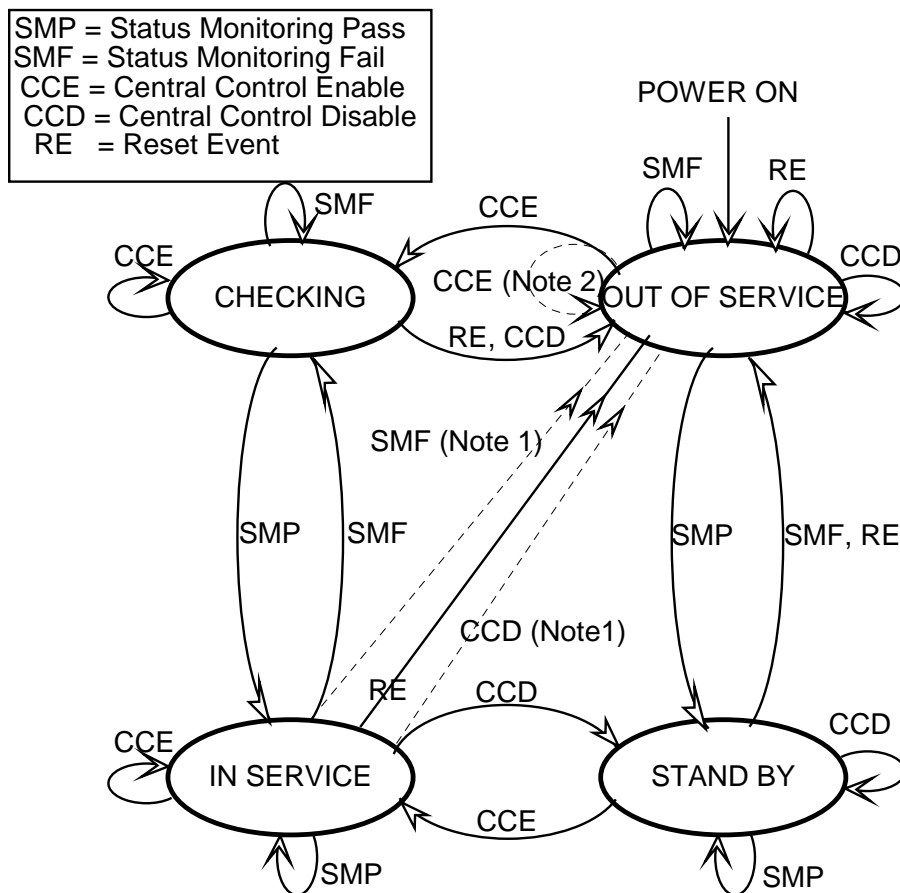

NOTE 1: In the "in-service" state, the occurrence of a SMF and/or CCD may result in a transition to the "out-of-service" state.

NOTE 2: In the "out-of-service" state, the occurrence of the first or all CCE event may be ignored.

Figure 2: State transition diagram of the control and monitoring function of a VSAT

4.2.6.1.3 Specification of states

The "checking" state shall apply when the SMV is "fail" and when the CV is "enable". In the "checking" state, the VSAT shall not transmit.

The "out-of-service" state shall apply when the SMV is "fail" and when the CV is "disable". In the "out-of-service" state the VSAT shall not transmit. This state shall be entered following power-on or reset.

The "stand-by" state shall apply when the SMV is "pass" and when the CV is "disable". In the "stand-by" state, the VSAT shall not transmit.

The "in-service" state applies when the SMV is "pass" and when the CV is "enable". In the "in-service" state the VSAT is allowed to transmit.

In the "out-of-service", "checking" and "stand-by" states the requirements for the "transmission disabled state" as specified in subclauses 4.2.1, 4.2.2 and 4.2.4 shall apply.

4.2.6.2 Control Channels (CC)

4.2.6.2.1 Justification

Control Channels (CC) are used to receive control information from the CCMF.

4.2.6.2.2 Specification

a) **Specification 1:**

The VSAT shall have at least one CC with the CCMF. The CC shall be either internal or external.

The type of CC (internal or external) shall be declared by the applicant.

NOTE 1: The availability of the external CC and the number of external CC are not within the scope of the present document.

NOTE 2: Some satellite operators may require that internal CC are available.

b) **Specification 2 for internal CC:**

The VSAT shall monitor the operation of its CC receive subsystem, i.e. its ability to lock to the received carrier frequency, demodulate, decode and receive messages from the CCMF.

Failure of the CC receive subsystem for a period of time longer than 30 seconds shall result in a SMF event. The corresponding change of state shall occur not later than 33 seconds after the beginning of the failure.

c) **Specification 3 for internal CC:**

The VSAT shall hold, in non-volatile memory, two unique identification codes:

- the identification code of the control channel or channels which it is authorized to receive; and
- the identification code of the VSAT when the CC is received by more than one VSAT.

Failure to receive and validate an authorized control identification code for a period of time not exceeding 60 seconds shall result in a SMF event. The corresponding change of state shall occur not later than 63 seconds after the beginning of the failure.

The VSAT shall be capable of receiving, via any authorized control channel, messages addressed to the VSAT containing CCD and CCE.

d) **Specification 4 for external CC:**

The VSAT shall be able either to be permanently connected to the CCMF or to be connected to the CCMF on demand, in order to receive messages from the CCMF containing CCD and CCE.

4.2.6.2.3 Conformance tests

Conformance tests shall be carried out in accordance with subclause 6.7.3.

4.2.6.3 Self monitoring functions

4.2.6.3.1 General

In order to ensure that all the subsystems of the VSAT are operating correctly during transmission, the following self monitoring functions shall be implemented in the VSAT:

- processor monitoring;
- transmit subsystem monitoring;
- VSAT transmission validation.

The successful verification of all conditions shall result in a SMP event.

The failure of any of the conditions shall result in a SMF event.

The monitoring functions shall be performed in all states of the VSAT.

4.2.6.3.2 Processor monitoring

4.2.6.3.2.1 Justification

To ensure that the VSAT can suppress transmissions in the event of a processor failure.

4.2.6.3.2.2 Specification

A VSAT shall incorporate a processor monitoring function for each of its processors involved in the manipulation of traffic and in the control and monitoring functions.

The processor monitoring function shall verify the correct operation of the processor hardware and software.

The detection by the processor monitoring function of a processor fault for a period of time not exceeding 30 seconds shall result in an SMF event. The corresponding change of state shall occur not later than 33 seconds after fault occurrence.

4.2.6.3.2.3 Conformance tests

Conformance tests shall be carried out in accordance with subclause 6.7.4.

4.2.6.3.3 Transmit subsystem monitoring

4.2.6.3.3.1 Justification

To ensure that the VSAT can suppress the transmissions in the event of a transmit subsystem error.

4.2.6.3.3.2 Specification

A VSAT shall monitor the operation of its transmit frequency generation subsystem.

Failure of the transmit frequency generation subsystem for a period of time not exceeding 5 seconds shall result in a SMF event. The corresponding change of state shall occur no later than 8 seconds after the beginning of the failure.

4.2.6.3.3.3 Conformance tests

Conformance tests shall be carried out in accordance with subclause 6.7.5.

4.2.6.3.4 VSAT transmission validation

4.2.6.3.4.1 General

For a VSAT using internal CC two alternative methods exist to confirm that the VSAT transmissions are being correctly received. These are:

- transmission validation by the CCMF in accordance with subclause 4.2.6.3.4.2;
- transmission validation by receiving station(s) in accordance with subclause 4.2.6.3.4.3.

For those VSAT using internal CC at least one of these methods shall be implemented.

For a VSAT using external CC the specification in subclause 4.2.6.3.4.4 applies.

4.2.6.3.4.2 VSAT transmission validation by the CCMF

4.2.6.3.4.2.1 Justification

To verify the ability of a transmitting VSAT to send status messages on request received from the CCMF, in order to have its correct operation validated.

4.2.6.3.4.2.2 Specification

When the VSAT is in the "in-service" state, and when it receives a "poll-for-status message" from the CCMF via a CC the VSAT shall transmit a "status message". The status message may be transmitted by the VSAT periodically thereafter without further stimuli from the CCMF.

The status message shall be transmitted via an internal RC.

NOTE: The status message is used by the CCMF to verify the correct operation of the VSAT.

4.2.6.3.4.2.3 Conformance tests

Conformance tests shall be carried out in accordance with subclause 6.7.6.1

4.2.6.3.4.3 VSAT transmission validation by receiving station(s)

4.2.6.3.4.3.1 Justification

To ensure that the VSAT transmits correctly, by informing the VSAT that its transmissions are being correctly received at receiving station(s).

For every 10 minutes during which the VSAT transmits at least once, the VSAT should receive at least one "transmission validation message" indicating that its transmissions are being received at the receiving station(s).

4.2.6.3.4.3.2 Specification

If no "transmission validation message" has been received by the VSAT for more than 10 minutes after any transmission, it shall result in a SMF event and the corresponding change of state shall occur not later than 11 minutes from the last "transmission validation message".

4.2.6.3.4.3.3 Conformance tests

Conformance tests shall be carried out in accordance with subclause 6.7.6.2

4.2.6.3.4.4 Transmission validation for VSAT using external CC

4.2.6.3.4.4.1 Purpose

To ensure that the transmitting VSAT remains controllable and transmits correctly, by requesting the VSAT to send to the CCMF one or multiple status messages.

4.2.6.3.4.4.2 Specification

When the VSAT is in the "in-service" state, and when it receives a "poll-for-status message" via the CC the VSAT shall respond with a "status message".

The "status message" shall be either:

- transmitted via an external RC and shall contain the values of the assigned EIRP and carrier frequencies of the VSAT; or
- transmitted via an internal RC. In this case, the "status message" is used by the CCMF to verify the correct transmission of the VSAT.

4.2.6.3.4.4.3 Conformance tests

Conformance tests shall be carried out in accordance with subclause 6.7.6.3.

4.2.6.4 Reception of commands from the CCMF

4.2.6.4.1 General

This subclause specifies the conditions the VSAT shall satisfy to consider that it is authorized to transmit.

4.2.6.4.2 Disable message

4.2.6.4.2.1 Justification

To verify the ability of a transmitting VSAT to suppress all its transmissions when it receives a CCD message from the CCMF.

4.2.6.4.2.2 Specification

Reception of a CCD message from the CCMF shall result in a CCD event and the corresponding change of state shall occur within 3 seconds of that event.

4.2.6.4.2.3 Conformance tests

Conformance tests shall be carried out in accordance with subclause 6.7.7.

4.2.6.4.3 Enable Message

4.2.6.4.3.1 Justification

To verify the ability of a VSAT to transmit when it has received a CCE message from the CCMF.

4.2.6.4.3.2 Specification

Reception of CCE message from the CCMF shall result in a CCE event.

4.2.6.4.3.3 Conformance tests

Conformance tests shall be carried out in accordance with subclause 6.7.8.

4.2.6.5 Power-on/Reset

4.2.6.5.1 Justification

To demonstrate that the VSAT achieves a controlled non-transmitting state following the powering-on of the unit, or the occurrence of a reset made by a local operator when this function is implemented.

4.2.6.5.2 Specification

Following "power-on" the VSAT shall enter the "out-of-service" state.

Following the application of a reset to the VSAT, a RE shall be considered to have taken place, causing the unit to enter the "out-of-service" state within 3 seconds.

NOTE: To leave the "out-of-service" state or the "stand by" state, the VSAT needs to receive a CCE message from the CCMF. This CCE message could be either:

- requested by the VSAT via an external CC not carried by the same VSAT network; or
- sent by the CCMF regularly via an internal CC; or
- via an external CC within the same VSAT network.

The manner of reception of this CCE remains a design matter.

4.2.6.5.3 Conformance tests

Conformance tests shall be carried out in accordance with subclause 6.7.8.

5 Testing for compliance with technical requirements

5.1 Environmental conditions for testing

Tests defined in the present document shall be carried out at representative points within the boundary limits of the declared operational environmental profile.

5.2 Essential radio test suites

The essential radio test suites for a complete VSAT are given in subclause 6 and for a modified VSAT in subclause 7.

6 Test methods for the complete VSAT

6.1 General

The values of measurement uncertainty associated with each measurement parameter apply to all of the test cases described in the present document. The measurement uncertainties shall not exceed the values shown in tables 6 and 7.

Table 6: Measurement uncertainty

Measurement parameter	Uncertainty
Radio frequency	±10 kHz
RF power	±0,75 dB
Conducted spurious	±4 dB
Radiated spurious	±6 dB
Antenna on-axis gain	±0,5 dB

Table 7: Measurement uncertainties for antenna gain pattern

Gain relative to the antenna on-axis gain	Uncertainty
> -3 dB	±0,3 dB
-3 dB to -20 dB	±1,0 dB
-20 dB to -30 dB	±2,0 dB
-30 dB to -40 dB	±3,0 dB

To enable the performance tests to be carried out the use of Special Test Equipment (STE), made available by the applicant or system provider, may be necessary. Since this test equipment will be specific for the particular system, it is not possible to provide detailed specifications in the present document. However, the following baseline is provided:

- if the VSAT requires to receive a modulated carrier from the satellite in order to transmit, then special test arrangements are required to simulate the satellite signal, thus enabling the VSAT to transmit allowing measurement of transmission parameters;
- any characteristic of these special test arrangements which may have direct or indirect effects on the parameters to be measured shall be clearly stated by the applicant.

All tests with carrier-on shall be undertaken with the transmitter operating at maximum power and with the maximum transmit burst rate, where applicable, which shall be declared by the applicant.

If the EUT is a VSAT that has had hardware and/or software modification(s) performed by the applicant for these tests then full documentation of such modification(s) shall be provided to prove that the modification(s) will simulate the required test condition. Such modification(s) shall be proved to allow the VSAT to operate without its main characteristics being changed.

The antenna shall not be rotated around its main beam axis.

All technical characteristics and operational conditions declared by the applicant shall be entered in the test report.

For VSAT already compliant with the present document and which have been modified the procedure set out in clause 7 shall apply if applicable.

6.2 Off-axis spurious radiation

The tests for the transmit VSAT specification 3) shall be limited to the carrier-on state.

6.2.1 Test method

6.2.1.1 General

An EUT with antenna is a VSAT with its antenna. It comprises both the indoor and outdoor units interconnected by 10 m of cable. An EUT without antenna is a VSAT with the removable antenna removed. It comprises both the indoor and outdoor units, up to the antenna flange, interconnected by at least 10 m of cable. The connecting cable between the indoor and the outdoor units shall be the same types as recommended by the applicant in the installation manual. The type of cable used shall be entered in the test report.

The indoor unit shall be terminated with matched impedances at the terrestrial ports if there is no associated equipment connected to such ports if recommended by the applicant in the user documentation.

For frequencies up to 80 MHz the measuring antenna shall be a balanced dipole with a length equal to the 80 MHz resonant length and shall be matched to the feeder by a suitable transforming device. Measurements with broad band antennas is also possible provided that the test site has been calibrated according to the requirements of CISPR 16-1 [2].

For frequencies between 80 MHz and 1 000 MHz the measuring antenna shall be a balanced dipole which shall be resonant in length. Measurements with broad band antennas is also possible provided that the test site has been calibrated according to the requirements of CISPR 16-1 [2].

For frequencies above 1 000 MHz the antenna shall be a horn radiator of known gain/frequency characteristics. When used for reception the antenna and any associated amplification system shall have an amplitude/frequency response within ± 2 dB of the combined calibration curves across the measurement frequency range considered for the antenna. The antenna is mounted on a support capable of allowing the antenna to be used in either horizontal or vertical polarization and at the specified height.

6.2.1.2 Up to 1 000 MHz

6.2.1.2.1 Test site

The test shall be performed either in an open area test site, a semi-anechoic chamber or an anechoic chamber. Ambient noise levels shall be at least 6 dB below the applicable unwanted emissions limit.

The open area test site shall be flat, free of overhead wires and nearby reflecting structures, sufficiently large to permit aerial placement at the specified measuring distance and provide adequate separation between aerial, test unit and reflecting structures, according to the specification of CISPR 16-1 [2].

For both the open area test site and the semi-anechoic chamber a metal ground plane shall be inserted on the natural ground plane and it shall extend at least 1 m beyond the perimeter of the EUT at one end and at least 1 m beyond the measurement antenna at the other end.

The distance between the EUT and measuring antenna shall be 10 m. An inverse proportionality factor of 20 dB per decade shall be used to normalize the measured data to the specified distance for determining compliance. Care should be taken in measurement of large test units at 3 m at frequencies near 30 MHz due to near field effects.

6.2.1.2.2 Measuring receivers

Measuring receivers shall conform to the following characteristics:

- the response to a constant amplitude sine wave signal shall remain within ± 1 dB across the frequency range of interest;
- quasi-peak detection shall be used in a -6 dB bandwidth of 120 kHz;
- the receiver shall be operated at more than 1 dB below the compression point during tests/measurements.

6.2.1.2.3 Procedure

- a) The EUT shall be an EUT with antenna or, preferably, without antenna but with the antenna flange terminated by a dummy load.
- b) The EUT shall be in the carrier-on state.
- c) The EUT shall be rotated through 360° and, except in an anechoic chamber, the measuring antenna height simultaneously varied from 1 m to 4 m above the ground plane.
- d) All identified spurious radiations shall be measured and noted in frequency and level.

6.2.1.3 Above 1 000 MHz

6.2.1.3.1 General

The spectrum analyser resolution bandwidth shall be set to the specified measuring bandwidth or as close as possible. If the resolution bandwidth is different from the specified measuring bandwidth, bandwidth correction shall be performed for the noise-like wideband spurious.

For an EUT with antenna the tests shall be performed in two stages for both the carrier-on and carrier-off states:

Procedure a): Identification of the significant frequencies of spurious radiation;

Procedure b): Measurement of radiated power levels of identified spurious radiation.

For an EUT without antenna the tests shall be performed in three stages for both the carrier-on and carrier-off states:

Procedure a): Identification of the significant frequencies of spurious radiation;

Procedure b): Measurement of radiated power levels of identified spurious radiation;

Procedure c): Measurement of conducted spurious radiation radiated through the antenna flange.

6.2.1.3.2 Identification of the significant frequencies of spurious radiation

6.2.1.3.2.1 Test site

The identification of frequencies emitting from the EUT shall be performed either in an anechoic chamber, an open area test site or a semi-anechoic chamber with the test antenna close to the EUT and at the same height as the volume centre of the EUT.

6.2.1.3.2.2 Procedure

- a) The EUT shall be in the carrier-off state (receive-only terminals shall be in the normal operating condition).
- b) For an EUT with antenna the main beam of the antenna shall have an angle of elevation of 7°, and, for an EUT without antenna the antenna flange shall be terminated by a dummy load.
- c) The receivers shall scan the frequency band whilst the EUT revolves.
- d) The EUT shall be rotated through 360° and the frequency of any spurious signals noted for further investigation.
- e) For an EUT with antenna the test shall be repeated with the test antenna being in the opposite polarization.
- f) For transmit capable equipment the test shall be repeated in the carrier-on state whilst transmitting one modulated carrier at maximum power.

6.2.1.3.3 Measurement of radiated power levels of identified spurious radiation

6.2.1.3.3.1 Test site

The measurement of each spurious radiation noted during procedure a) of the test shall be performed on a test site that is free from reflecting objects, i.e. either an open-area test site, a semi-anechoic chamber or an anechoic chamber.

6.2.1.3.3.2

Procedure

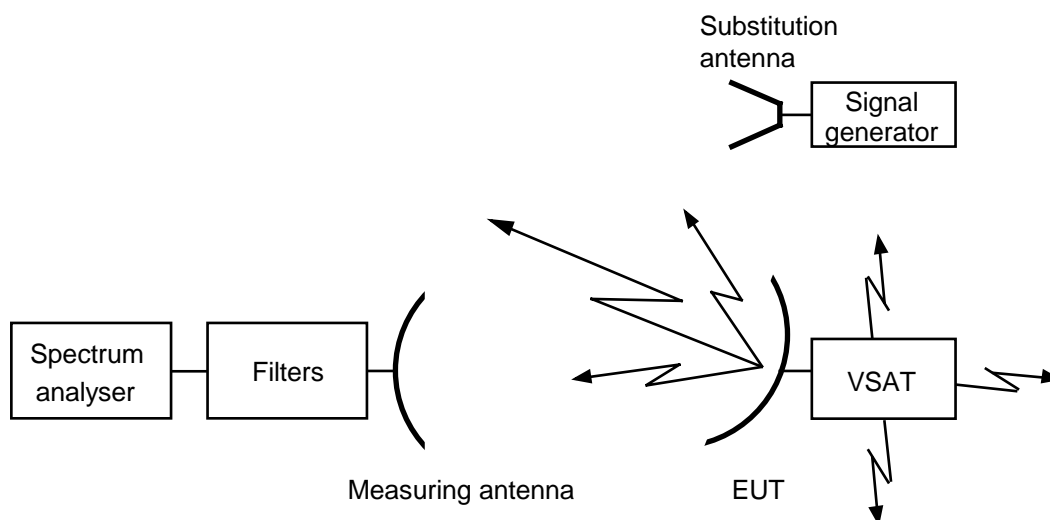

Figure 3: Test arrangement - Spurious radiation measurement above 1 000 MHz for an EUT with antenna

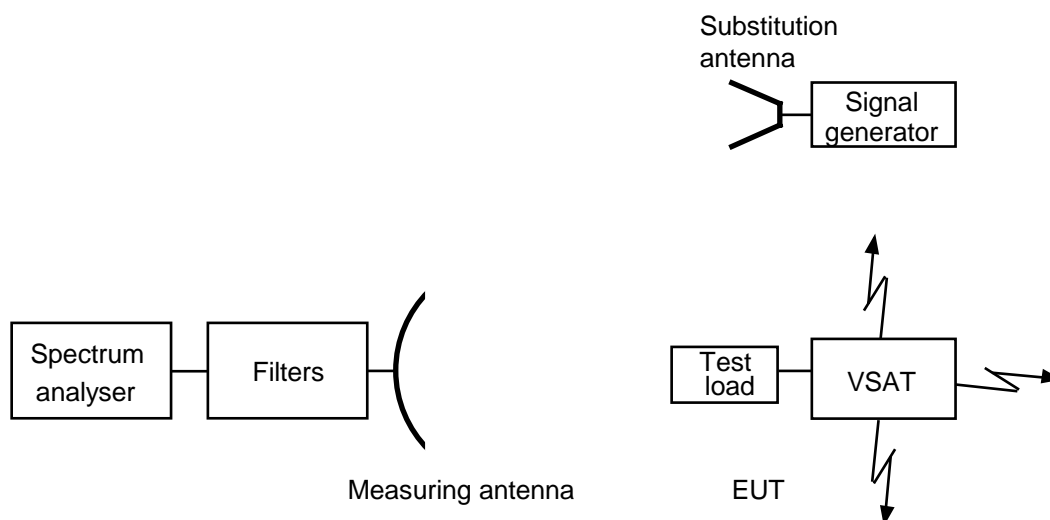

Figure 4: Test arrangement - spurious radiation measurements above 1 000 MHz for an EUT without antenna

- a) The test arrangement shall be as shown in figure 3 or 4.
- b) The EUT shall be installed such that the units are separated by about 1 m to 2 m with the indoor unit at a height between 0,5 m and 1,0 m on a turntable. The interconnection cable shall be maintained by non-metallic means at a height between 0,5 m and 1,0 m. For the test arrangement shown in figure 3 the main beam of the antenna shall have an angle of elevation of 7° and be oriented away from the geostationary orbit, or be inhibited by placing RF absorbing panels in that direction. For antennas designed for minimum off-axis gain in the direction of the geostationary orbit plane, the plane containing the larger cut of the main lobe shall be set vertical.
- c) The measuring antenna shall be positioned at a distance from the EUT (e.g. 3, 5, 10 m) relevant to the applied test site. The measuring antenna shall be adjusted in height and the EUT rotated, whilst the EUT is in the appropriate carrier condition, for a maximum response on the associated spectrum analyser at each spurious frequency previously identified, this response level shall be noted. The adjustment in height of the measuring antenna does not apply when an anechoic chamber is being used. The measuring antenna shall never enter the 7° off-axis cone around the main beam direction.
- d) The investigation shall be repeated with the measuring antenna in the opposite polarization and the response level similarly noted.

- e) The EUT shall be replaced by the substitution antenna to which is connected a signal generator. The main beam axes of the measuring and substitution antennas shall be aligned. The distance between these antennas shall be the distance determined under test c).
- f) The substitution and measuring antennas shall be aligned in the polarization which produced the larger response between the EUT and the test antenna in steps c) and d).
- g) The output of the generator shall be adjusted so that the received level is identical to that of the previously noted largest spurious radiation.
- h) The output level of the signal generator shall be noted. The EIRP of the spurious radiation is the sum, in dB, of the signal generator output plus the substitution antenna isotropic gain minus the interconnection cable loss.

6.2.1.3.4 Measurement of conducted spurious radiation at the antenna flange

6.2.1.3.4.1 Test site

There are no requirements for the test site to be used for this test.

6.2.1.3.4.2 Procedure

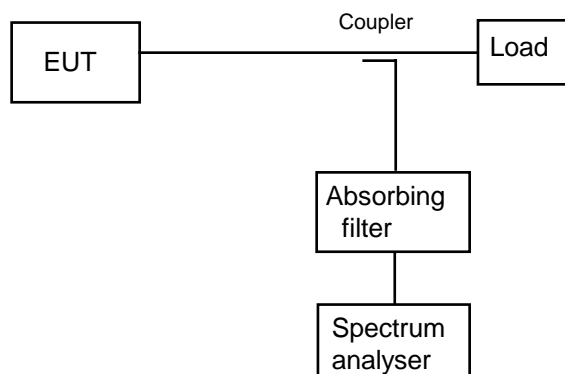

Figure 5: Test arrangement - conducted spurious radiation above the cut-off frequency

- a) The test arrangement shall be as shown in figure 5. In order to protect the spectrum analyser while ensuring the necessary measurement accuracy, particularly close to the carrier, if an absorbing filter is used it shall be tuned to the transmit carrier frequency.
- b) The frequency range from the cut-off frequency of the waveguide of the EUT to 40 GHz shall be investigated for spurious radiation whilst in the carrier-on state with the carrier being at maximum power and normally modulated.
- c) To obtain the off-axis spurious EIRP the maximum measured antenna transmit gain, measured at the frequency of the identified unwanted emission, for off-axis angles greater than 7° , shall be added to the measured power density and any correction or calibration factors summated with the result. If agreed by the applicant, it shall be acceptable that the worst case value assumed (i.e. 8 dBi for off-axis angles greater than 7°) is used in place of the maximum off-axis antenna gain at the frequency of the identified unwanted emission.
- d) The test shall be repeated, for transmit capable equipment, in the carrier-off state.

6.3 On-axis spurious radiation

6.3.1 Test method

6.3.1.1 Test site

There are no requirements for the test site to be used for this test.

6.3.1.2 Method of measurement

6.3.1.2.1 General

For VSAT equipment for which measurements at the antenna flange are not possible or not agreed by the applicant, the measurements shall be performed with a test antenna.

For VSAT equipment for which measurements at the antenna flange are possible and agreed by the applicant, the measurements shall be performed at the antenna flange.

6.3.1.2.2 Method of measurement at the antenna flange

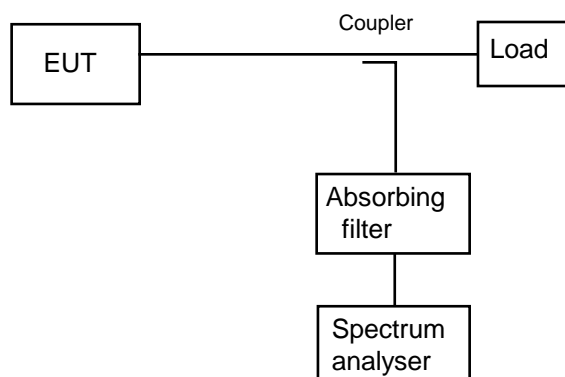

Figure 6: Test arrangement - on-axis spurious radiation measurements at the antenna flange

- a) The test arrangement shall be as shown in figure 6. In order to protect the Spectrum Analyser while ensuring the necessary measurement accuracy, particularly close to the carrier, if an absorbing filter is used it shall be tuned to the transmit carrier frequency.
- b) The EUT shall transmit one modulated carrier continuously, or at its maximum burst rate where applicable, centred on a frequency as close to the lower limit of the operating frequency band of the EUT as possible. The EUT shall be operated at the highest normal operating EIRP. The frequency range 14,00 GHz to 14,50 GHz shall be investigated.
- c) Due to the proximity of the carrier the spectrum analyser resolution bandwidth shall be set to a measurement bandwidth of 3 kHz, or as close as possible. If the measurement bandwidth is different from the specified measurement bandwidth, bandwidth correction shall be performed for noise-like wideband spurious radiation.
- d) To obtain the on-axis spurious EIRP, the antenna transmit gain shall be added to any figure obtained in the above measurement and any correction or calibration factor summated with the result. The antenna gain shall be as measured in subclause 6.4.1.3 at the closest frequency to the spurious frequency.
- e) The tests in b) to e) shall be repeated with a transmit frequency in the centre of the operating frequency band.
- f) The tests in b) to e) shall be repeated with a transmit frequency as close to the upper limit of the operating frequency band of the EUT as possible.
- g) The test shall be repeated in the carrier-off state.
- h) The test shall be repeated in the "transmission disabled state".

6.3.1.2.3 Method of measurement with a test antenna

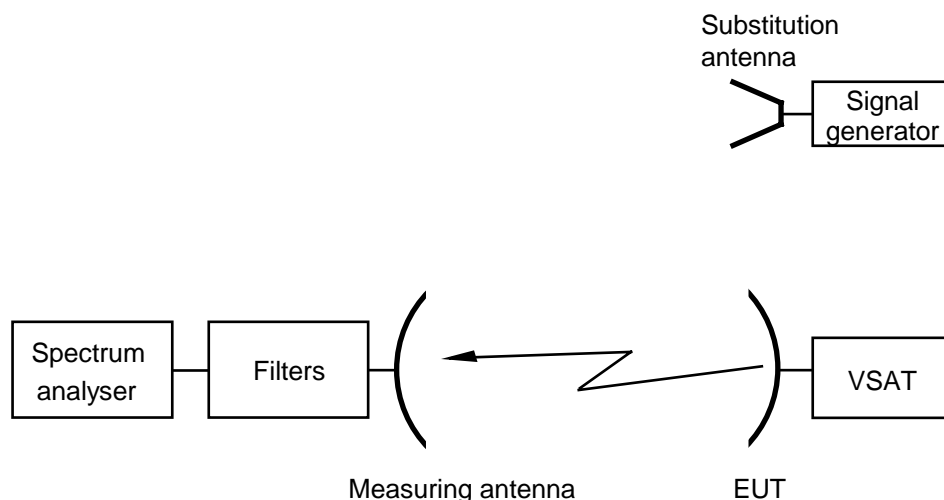

Figure 7: Test arrangement - on-axis spurious radiation measurements for an EUT with antenna

- a) The test arrangement shall be as shown in figure 7.
- b) The EUT shall be installed such that the units are separated by about 1 m to 2 m with the indoor unit at a height between 0,5 m and 1,0 m on a turntable. The interconnection cable shall be maintained by non-metallic means at a height between 0,5 m and 1,0 m.
- c) The spectrum analyser resolution bandwidth shall be set to the specified measuring bandwidth or as close as possible. If the resolution bandwidth is different from the specified measuring bandwidth, bandwidth correction shall be performed for noise-like wideband spurious radiation.
- d) The EUT shall transmit one modulated carrier continuously, or at its maximum burst rate where applicable, centred on a frequency as close to the lower limit of the operating frequency band of the EUT as possible. The EUT shall be operated at the highest normal operating EIRP. The frequency range 14,00 GHz to 14,50 GHz shall be investigated and each spurious frequency shall be noted.
- e) Due to the proximity of the carrier the spectrum analyser resolution bandwidth shall be set to a measurement bandwidth of 3 kHz, or as close as possible. If the measurement bandwidth is different from the specified measurement bandwidth, bandwidth correction shall be performed for noise-like wideband spurious radiation.
- f) The measuring antenna shall be positioned at a distance from the EUT (e.g. 3, 5, 10 m) relevant to the applied test site and shall be aligned with the EUT antenna for the transmit frequency. The measuring antenna shall be adjusted in height, whilst the EUT is in the appropriate carrier condition, for a maximum response on the associated spectrum analyser at each spurious frequency previously identified, this response level shall be noted. The adjustment in height of the measuring antenna does not apply when an anechoic chamber is being used.
- g) The EUT shall be replaced by the substitution antenna to which is connected a signal generator. The main beam axes of the measuring and substitution antennas shall be aligned. The distance between these antennas shall be the distance determined under test f).
- h) The substitution and measuring antennas shall be aligned in the polarization which produced the larger response between the EUT and the test antenna.
- i) The output of the generator shall be adjusted so that the received level is identical to that of the previously noted largest spurious radiation.
- j) The output level of the signal generator shall be noted. The EIRP of the on-axis spurious radiation is the sum, in dB, of the signal generator output plus the substitution antenna isotropic gain minus the interconnection cable loss.
- k) The tests in d) to j) shall be repeated with a transmit frequency in the centre of the operating frequency band.

- l) The tests in d) to j) shall be repeated with a transmit frequency as close to the upper limit of the operating frequency band of the EUT as possible.
- m) The test shall be repeated in the carrier-off state.
- n) The test shall be repeated in the "transmission disabled state" state.

6.4 Off-axis EIRP emission density within the band

Off-axis EIRP emission density (co-polar and cross-polar) within the band 14,0 GHz to 14,5 GHz.

6.4.1 Test method

6.4.1.1 General

To ascertain the off-axis EIRP it is necessary to know the transmit power density and antenna transmit radiation pattern. To ascertain the radiation pattern it is necessary to know the antenna transmit gain.

The following three measurement procedures shall, therefore, be performed:

- a) transmit output power density (dBW/40 kHz);
- b) antenna transmit gain (dBi);
- c) antenna transmit radiation patterns (dBi).

6.4.1.2 Transmit output power density

6.4.1.2.1 General

For the purpose of the present document, transmit output power is defined as the maximum power delivered continuously by the transmitting equipment to the antenna flange.

For the purpose of this test the EUT is defined as the indoor unit and that part of the outdoor unit up to the antenna flange.

6.4.1.2.2 Test site

There are no requirements for the test site to be used for this test.

6.4.1.2.3 Method of measurement

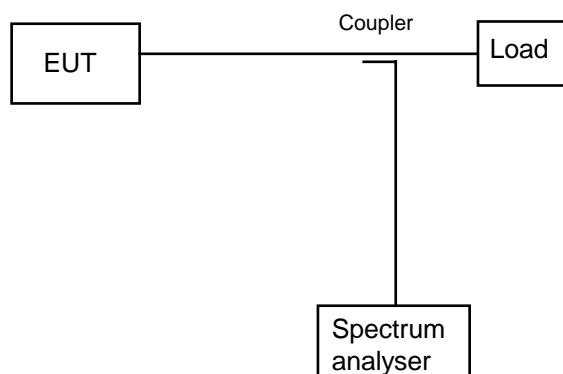

Figure 8: Test arrangement - transmit output power density measurement

- a) The test arrangement shall be as shown in figure 8.

- b) With the carrier being modulated by a pseudo random signal, the maximum power supplied to the antenna flange shall be measured in dBW/40 kHz. The coupling factor of the test coupler at the test frequency and the attenuation of any necessary waveguide adapter shall be taken into account. The resolution bandwidth of the spectrum analyser shall be set as close as possible to the specified measuring bandwidth. If the resolution bandwidth is different from the specified bandwidth then bandwidth correction shall be performed.

6.4.1.3 Antenna transmit gain

6.4.1.3.1 General

For the purpose of the present document, the antenna transmit gain is defined as the ratio, expressed in decibels (dBi), of the power that would have to be supplied to the reference antenna, i.e. an isotropic radiator isolated in space, to the power supplied to the antenna being considered, so that they produce the same field strength at the same distance in the same direction. Unless otherwise specified the gain is for the direction of maximum radiation.

For the purpose of this test the EUT is defined as that part of the outdoor unit which comprises the antenna and its flange. The antenna includes the reflector(s), feed, support struts and an enclosure of equal weight/distribution to any electrical equipment normally housed with the feed at the antenna focal point.

6.4.1.3.2 Test site

This test shall be performed on either an outdoor far-field test site or compact test range. However if the near-field scanner technology to convert near-field measurements to far-field results is proven and sufficiently accurate by reference to tests taken in both regions then antenna measurements may be taken in the near field. Fully automated systems can be used for these tests providing that the results can be proven to be as accurate as if they were done according to the specified method.

6.4.1.3.3 Method of measurement

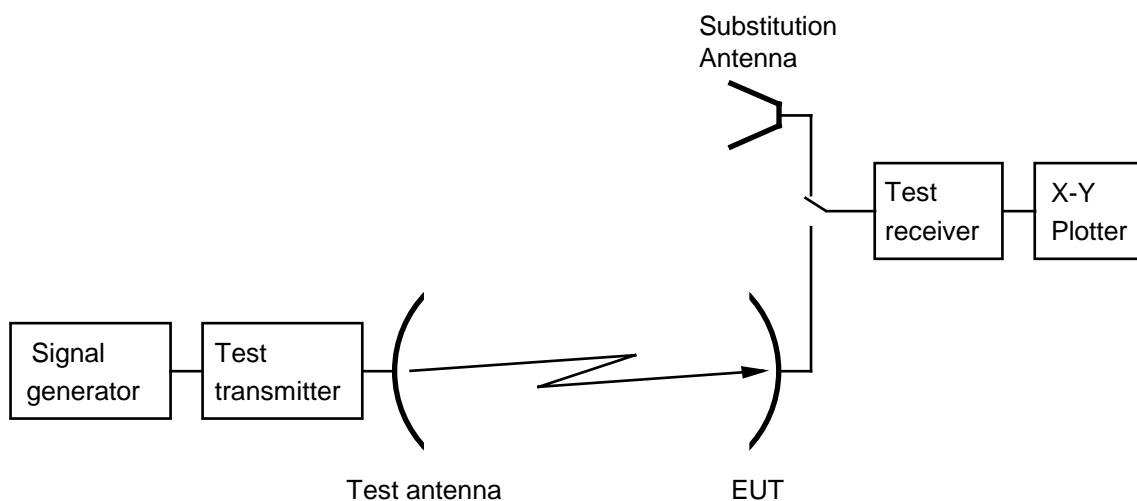

Figure 9: Test arrangement - antenna transmit gain measurement

- The test arrangement shall be as shown in figure 9 with the EUT connected to the test receiver. A signal proportional to the angular position from the servo mechanism shall be applied to the X-axis and the signal level from the test receiver shall be applied to the Y-axis of the plotter.
- A test signal at 14,250 GHz shall be transmitted by the test transmitter through the test antenna. The E-plane shall be vertical. The EUT antenna main beam axis shall be aligned with the main beam axis of the test transmitter. The polarizer of the EUT antenna shall be rotated and adjusted such that the E-plane coincides with the E-plane of the test transmitter.
- The EUT shall be aligned to maximize the received signal and the X-Y plotter adjusted to give the maximum reading on the chart.
- The EUT shall be driven in azimuth in one direction through 10°.

- e) The pattern measurement is then obtained by driving the EUT in azimuth back through boresight to 10° the other side with the plotter recording the results.
- f) The EUT shall be replaced by the substitution antenna and the received signal level maximized.
- g) This level shall be recorded on the X-Y plotter.
- h) The substitution antenna shall be driven in azimuth as in d) and e).
- i) The gain of the EUT shall be calculated from:

$$G_{\text{EUT}} = L_1 - L_2 + C$$

where:

G_{EUT} is the gain of the EUT (dBi);

L_1 is the level obtained with the EUT (dB);

L_2 is the level obtained with the substitution antenna (dB);

C is the calibrated gain of the substituted antenna at the test frequency (dBi).

- j) The tests in c) to i) shall be repeated with the frequency changed to 14,005 GHz.
- k) The tests in c) to i) shall be repeated with the frequency changed to 14,495 GHz.
- l) The tests in b) to k) may be performed simultaneously.

6.4.1.4 Antenna transmit radiation patterns

6.4.1.4.1 General

For the purpose of the present document, the antenna transmit radiation patterns are diagrams relating field strength to the angle of the direction pointed by the antenna at a constant large distance from the antenna.

For the purpose of this test, the EUT is defined as that part of the outdoor unit which comprises the antenna and its flange. The antenna includes the reflector(s), feed, support struts and an enclosure of equal weight/distribution to any electrical equipment normally housed with the feed at the antenna focal point.

6.4.1.4.2 Test site

This test shall be performed on either an outdoor far-field test site or compact test range. However, if the near-field scanner technology to convert near-field measurements to far-field results is proven and sufficiently accurate by reference to tests taken in both regions then antenna measurements may be taken in the near field. Fully automated systems can be used for these tests providing that the results can be proven to be as accurate as if they were done according to the specified method.

6.4.1.4.3 Test arrangement

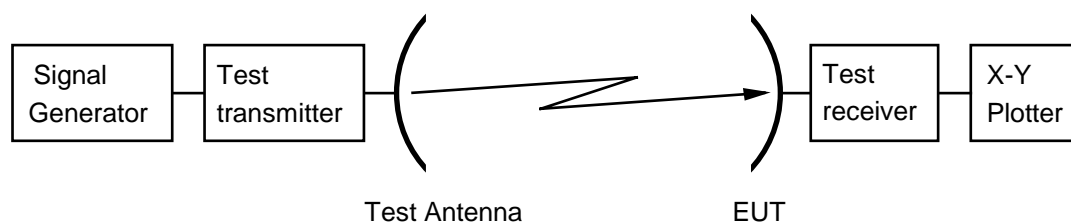

Figure 10: Test arrangement - antenna transmit radiation pattern measurement

6.4.1.4.4 Co-polar radiation pattern - azimuth

- a) The test arrangement shall be as shown in figure 10 with the EUT connected to the test receiver. A signal proportional to the angular position from the servo mechanism shall be applied to the X-axis and the signal level from the test receiver shall be applied to the Y-axis of the plotter.
- b) The frequency of the test signal shall be set to 14,250 GHz.
- c) The initial E-plane of the test signal radiated by the test transmitter through its antenna shall be vertical. The EUT antenna main beam axis shall be aligned with the main beam axis of the test transmitter. The polarizer of the EUT antenna shall be rotated and adjusted such that its E-plane coincides with the E-plane of the test transmitter. Precise co-polar peaking of the polarization shall be done by observing the cross-polar minimum (fine adjustment).
- d) The EUT shall be aligned to maximize the received signal and the X-Y plotter adjusted to give the maximum reading on the chart.
- e) The EUT shall be driven in azimuth to -180° .
- f) The transmit pattern measurement is then obtained by driving the EUT in azimuth from -180° to $+180^\circ$ with the plotter recording the results.
- g) The tests in d) to f) shall be repeated with the frequency changed to 14,005 GHz.
- h) The tests in d) to f) shall be repeated with the frequency changed to 14,495 GHz.
- i) The tests in b) to h) may be performed simultaneously.
- j) The tests in d) to i) shall be repeated with the E-plane of the test signal being horizontal. The frequency of the test signal shall be set to 14,250 GHz. The polarizer of the EUT antenna shall be rotated and adjusted such that its E-plane coincides with the E-plane of the test transmitter (giving the minimum cross-polar receive signal).

6.4.1.4.5 Co-polar radiation pattern - elevation

- a) The test arrangement shall be as shown in figure 10 with the EUT connected to the test receiver. A signal proportional to the angular position from the servo mechanism shall be applied to the X-axis and the signal level from the test receiver shall be applied to the Y-axis of the plotter.
- b) The frequency of the test signal shall be set to 14,250 GHz.
- c) The initial E-plane of the test signal radiated by the test transmitter through its antenna shall be vertical. The EUT antenna main beam axis shall be aligned with the main beam axis of the test transmitter. The polarizer of the EUT antenna shall be rotated and adjusted such that its E-plane coincides with the E-plane of the test transmitter. Precise co-polar peaking of the polarization shall be done by observing the cross-polar minimum (fine adjustment).
- d) The EUT shall be aligned to maximize the received signal and the X-Y plotter adjusted to give the maximum reading on the chart.
- e) The EUT shall be driven in elevation to -1° .
- f) The transmit pattern measurement is then obtained by driving the EUT in elevation from -1° to 70° with the plotter recording the results.
- g) The tests in d) to f) shall be repeated with the frequency changed to 14,005 GHz.
- h) The tests in d) to f) shall be repeated with the frequency changed to 14,495 GHz.
- i) The tests in b) to h) may be performed simultaneously.

- j) The tests in d) to i) shall be repeated with the E-plane of the test signal being horizontal. The frequency of the test signal shall be set to 14,250 GHz. The polarizer of the EUT antenna shall be rotated and adjusted such that its E-plane coincides with the E-plane of the test transmitter. The EUT antenna main beam axis shall be aligned with the main beam axis of the test transmitter. Precise co-polar peaking of the polarization plane shall be done by observing the cross-polar minimum (fine adjustment).

6.4.1.4.6 Cross-polar radiation pattern - azimuth

- a) The test arrangement shall be as shown in figure 10 with the EUT connected to the test receiver. A signal proportional to the angular position from the servo mechanism shall be applied to the X-axis and the signal level from the test receiver shall be applied to the Y-axis of the plotter.
- b) The frequency of the test signal shall be set to 14,250 GHz.
- c) The initial E-plane of the test signal radiated by the test transmitter through its antenna shall be vertical. The EUT antenna main beam axis shall be aligned with the main beam axis of the test transmitter. The polarizer of the EUT antenna shall be rotated and adjusted such that its E-plane is orthogonal to the E-plane of the test transmitter. Precise fine adjustment of the polarization plane shall be done by observing the cross-polar minimum.
- d) In order to adjust the X-Y plotter giving the maximum reading on the chart the boresight co-polar receive signal shall be used.
- e) The EUT shall be driven in azimuth to -10° .
- f) The transmit pattern measurement is then obtained by driving the EUT in azimuth from -10° to $+10^\circ$ with the plotter recording the results.
- g) The tests in d) to f) shall be repeated with the frequency changed to 14,005 GHz.
- h) The tests in d) to f) shall be repeated with the frequency changed to 14,495 GHz.
- i) The tests in b) to h) may be performed simultaneously.
- j) The tests in d) to i) shall be repeated with the E-plane of the test signal being horizontal. The frequency of the test signal shall be set to 14,250 GHz. The EUT antenna main beam axis shall be aligned with the main beam axis of the test transmitter. The polarizer of the EUT antenna shall be rotated and adjusted such that its E-plane is orthogonal with the E-plane of the test transmitter. Precise fine adjustment of the polarization plane shall be done by observing the cross-polar minimum.

6.4.1.4.7 Cross-polar radiation pattern - elevation

- a) The test arrangement shall be as shown in figure 10 with the EUT connected to the test receiver. A signal proportional to the angular position from the servo mechanism shall be applied to the X-axis and the signal level from the test receiver shall be applied to the Y-axis of the plotter.
- b) The frequency of the test signal shall be set to 14,250 GHz.
- c) The initial E-plane of the test signal radiated by the test transmitter through its antenna shall be vertical. The EUT antenna main beam axis shall be aligned with the main beam axis of the test transmitter. The polarizer of the EUT antenna shall be rotated and adjusted such that its E-plane is orthogonal to the E-plane of the test transmitter. Precise fine adjustment of the polarization plane shall be done by observing the cross-polar minimum.
- d) In order to adjust the X-Y plotter giving the maximum reading on the chart the boresight co-polar receive signal shall be used.
- e) The EUT shall be driven in elevation to -1° .
- f) The transmit pattern measurement is then obtained by driving the EUT in elevation from -1° to $+10^\circ$ with the plotter recording the results.
- g) The tests in d) to f) shall be repeated with the frequency changed to 14,005 GHz.
- h) The tests in d) to f) shall be repeated with the frequency changed to 14,495 GHz.

- i) The tests in b) to h) may be performed simultaneously.
- j) The tests in d) to i) shall be repeated with the E-plane of the test signal being horizontal. The frequency of the test signal shall be set to 14,250 GHz. The EUT antenna main beam axis shall be aligned with the main beam axis of the test transmitter. The polarizer of the EUT antenna shall be rotated and adjusted such that its E-plane is orthogonal with the E-plane of the test transmitter. Precise fine adjustment of the polarization plane shall be done by observing the cross-polar minimum.

6.4.2 Computation of results

The results shall be computed by producing a "mask" to the specified limits with the reference level being equal to the sum of the transmitter output power density and the gain of the antenna. This reference shall then be placed on the maximum point of the plots obtained from the transmit radiation pattern measurements, so as to ascertain that the off-axis EIRP density is within the mask, and thus conforming to the specification.

6.5 Carrier suppression

6.5.1 Test method

- a) The test arrangement for conducted measurements shall be as shown in figure 6. The test arrangement for radiated measurements shall be as shown in figure 7.
- b) The EUT shall transmit one modulated carrier continuously, or at its maximum burst rate where applicable, centred on 14,250 GHz.
- c) The resolution bandwidth of the spectrum analyser shall be set to 3 kHz.
- d) The "transmission disabled state" shall be obtained by use of the CCMF.
- e) For conducted measurements the maximum residual carrier power density within the nominated bandwidth shall be measured and added to the antenna on-axis gain.
- f) For radiated measurements the maximum residual EIRP density within the nominated bandwidth shall be measured and recorded.

Instead of the CCMF an STE provided by the applicant may be used to enable the VSAT transmission to be suppressed.

6.6 Antenna pointing for transmit VSAT

6.6.1 Test method

- a) Pointing stability:
 - as it is considered impracticable to perform the test on pointing stability no test is given;
 - the test methodology described in annex B (informative) may be used to show compliance with the specification for pointing stability.
- b) Pointing accuracy capability:
 - 1) the EUT shall be inspected to ascertain whether fine adjustment facilities are available for the azimuth axis (coarse adjustment is usually provided by the positioning of the means of attachment);
 - 2) the adjustment facilities shall be examined to determine both the angular movement possible and the means of arresting that movement;
 - 3) the arresting facility shall be examined to determine its permanency;
 - 4) the test shall be repeated for the elevation axis.

c) Polarization angle alignment capability:

- 1) the adjustment facilities shall be examined to determine both the angular movement possible and the means of arresting that movement;
- 2) the arresting facility shall be examined to determine its permanency.

6.7 Control and monitoring for transmit VSAT

6.7.1 General

For the purpose of this test the EUT is defined as the indoor unit and that part of the outdoor unit up to the antenna flange.

The measurement of the EIRP spectral density shall be limited to the on-axis EIRP spectral density within either the nominated bandwidth or to a 10 MHz bandwidth centred on the carrier frequency, whichever is the greater.

6.7.2 Test arrangement

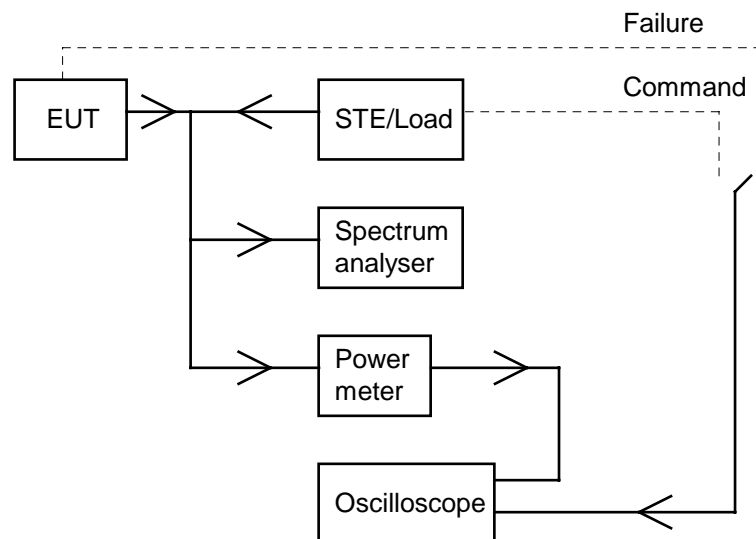

Figure 11: General test arrangement for control and monitoring tests for conducted measurements

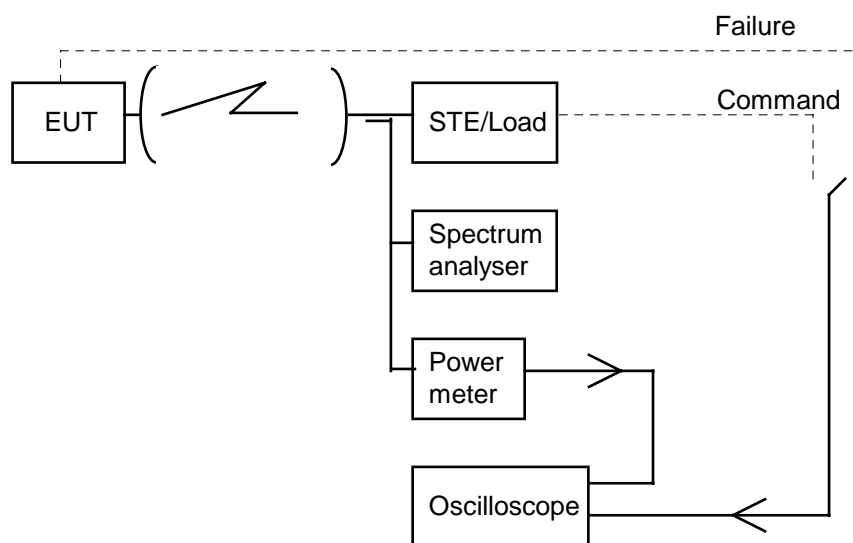

Figure 12: General test arrangement for control and monitoring tests for radiated measurements

The test arrangement shall be as shown in figure 11 or 12. The EUT shall be authorized to transmit and shall be in the carrier-on state at the commencement of each test. The dual trace storage oscilloscope shall monitor by measuring the time difference between the command, or failure, and the occurrence of the expected event (e.g. the transmission suppression). The power meter and spectrum analyser shall monitor the EUT output level.

6.7.3 Control Channels (CC)

6.7.3.1 Test method

- a) The type of CC (internal or external) shall be entered in the test report.
- b) The characteristics of any external CC interface of the VSAT, including protocols, shall be recorded in the test report.
- c) Apply the test method described in subclause 6.7.3.1.1 to internal CC.
- d) Apply the test method described in subclause 6.7.3.1.2 to external CC.

6.7.3.1.1 Test method for internal CC

- a) The CC receive subsystem shall be caused to fail.
- b) Recognition of this shall constitute a SMF event.
- c) Within 33 seconds of the failure the EUT shall cease to transmit as seen on the spectrum analyser.
- d) The power meter and spectrum analyser shall be observed to ascertain that the transmissions have been suppressed (transmission disabled state).
- e) The CC receive subsystem shall be restored and the EUT shall be able to transmit again after a CCE message is received from the CCMF.
- f) The unique identification code for the EUT shall be removed from the CC.
- g) Recognition of this shall constitute a SMF event.
- h) Within 63 seconds of the loss of identification code the EUT shall cease to transmit as seen on the spectrum analyser.
- i) The power meter and spectrum analyser shall be observed to ascertain that the transmissions have been suppressed (transmission disable state).
- j) The unique identification code for the EUT shall be restored and the EUT shall be able to transmit again after a CCE message is received from the CCMF.
- k) The unique identification code for the control channel(s) shall be removed from the CC.
- l) Recognition of this shall constitute a SMF event.
- m) Within 63 seconds of the loss of CC identification code the EUT shall cease to transmit as seen on the spectrum analyser.
- n) The power meter and spectrum analyser shall be observed to ascertain that the transmissions have been suppressed (transmission disabled state).
- o) The unique identification code for the CC shall be restored and the EUT shall be able to transmit again after a CCE message is received from the CCMF.

6.7.3.1.2 Test method for external CC

- a) The CC shall be established.
- b) The test described in subclause 6.7.7 shall be conducted.

6.7.4 Processor monitoring

6.7.4.1 Test method

- a) Each of the processors within the EUT shall, in turn, be caused to fail.
- b) Recognition of each failure in turn by the processor monitor shall constitute a SMF event.
- c) Within 33 seconds of each failure the EUT shall cease to transmit as seen on the spectrum analyser.
- d) The power meter and spectrum analyser shall be observed to ascertain that the transmissions have been suppressed (transmission disabled state).
- e) The failed processor shall be restored to normal working condition and the EUT restored to normal working condition before the next processor shall be induced to fail.

6.7.5 Transmit subsystem monitoring

6.7.5.1 Test method

- a) The frequency generation subsystem shall be caused to fail in respect of:
 - 1) frequency stability;
 - 2) output.
- b) Recognition of each failure in turn by the subsystem monitor shall constitute a SMF event.
- c) Within 9 seconds of the failure the EUT shall cease to transmit as seen on the spectrum analyser.
- d) The power meter and spectrum analyser shall be observed to ascertain that the transmissions have been suppressed (transmission disabled state).
- e) The frequency generation shall be restored to normal working condition and the EUT restored to normal working condition before the next induced failure.

6.7.6 VSAT transmission validation

6.7.6.1 Test method for VSAT validation by the CCMF for VSAT using internal CC

- a) The EUT shall be in the "in-service" state and a "poll for status" message shall be received from the CCMF a CC.
- b) The EUT shall immediately transmit a status message to the CCMF via an internal RC.

6.7.6.2 Test method for VSAT validation by receiving station(s) for VSAT using internal CC

- a) The EUT shall be transmitting. The "transmission validation message" from the receiving station shall be suppressed.
- b) No later than 11 minutes after the suppression of the transmission validation message the EUT shall recognize a SMF event and cease to transmit as seen on the spectrum analyser.
- c) The power meter and spectrum analyser shall be observed to ascertain that the transmissions have been suppressed (transmission disabled state).

6.7.6.3 Test method for transmission validation for VSAT using external CC

- a) The EUT shall be in the "in-service" state and a "poll for status" message shall be received from the CCMF via a CC.

- b) The EUT shall immediately transmit a status message to the CCMF via an internal RC, or an external RC.
- c) For external RC(s) the contents of the status message shall be verified.

6.7.7 Reception of commands from the CCMF

6.7.7.1 Test method

- a) A CCD message shall be received from the CCMF by the EUT.
- b) The EUT shall recognize this as a CCD event.
- c) Within 3 seconds of the receipt of the CCD message the EUT shall cease to transmit as seen on the spectrum analyser.
- d) The power meter and spectrum analyser shall be observed to ascertain that the transmissions have been suppressed (transmission disabled state).
- e) A CCE message shall be received from the CCMF by the EUT.
- f) The EUT shall recognize this as a CCE event.
- g) Within 3 seconds of the receipt of the CCE message the EUT shall be enabled to start transmission.

6.7.8 Power-on/Reset

6.7.8.1 Test method

- a) Remove the power supplying the EUT.
- b) Stop the CCMF from transmitting the CCE.
- c) Replace the power supplying the EUT.
- d) The EUT shall enter the out of service state, i.e. no transmission shall be observed on the spectrum analyser.
- e) The power meter and spectrum analyser shall be observed to ascertain that the transmissions have been suppressed (transmission disabled state).
- f) The system shall be restored and the EUT shall be able to transmit again after a CCE message is received from the CCMF.
- g) Reset the EUT.
- h) The EUT shall recognize this as an RE event.
- i) Within 3 seconds of the reset the EUT shall cease to transmit as seen on the spectrum analyser.
- j) The power meter and spectrum analyser shall be observed to ascertain that the transmissions have been suppressed.

7 Test methods for modified VSAT

7.1 General

The modifications of a VSAT may consist of the replacement of one or several of the following modules:

- a) antenna subsystem;
- b) High Power Amplifier (HPA);
- c) up converter;
- d) Low Noise Amplifier (LNA);
- e) down converter;
- f) modulator/demodulator (modem).

The intermediate and final results of the VSAT tests before modification shall be made available by the applicant.

7.2 Antenna subsystem replacement

This subclause is only applicable to passive antennas.

The following measurements made on the VSAT before modification shall not be repeated:

- 6.2.1.2.3 Procedure for off-axis spurious radiation up to 1 000 MHz;
- 6.2.1.3.2 Identification of the significant frequencies of spurious radiation;
- 6.2.1.3.3 Measurement of radiated power levels of identified spurious radiation (EUT without antenna);
- 6.2.1.3.4 Measurement of conducted spurious radiation at the antenna flange;
- 6.3.1.2.2 Method of measurement at the antenna flange of on-axis spurious radiation;
- 6.4.1.2 Transmit output power density;
- 6.5 Carrier suppression;
- 6.7 Control and monitoring for transmit VSAT.

The results of these measurements shall be used as those of the unmodified VSAT and entered in the computation of these subclauses.

Annex A (normative): The EN Requirements Table (EN-RT)

Notwithstanding the provisions of the copyright clause related to the text of the present document, ETSI grants that users of the present document may freely reproduce the EN-RT proforma in this annex so that it can be used for its intended purposes and may further publish the completed EN-RT.

The EN Requirements Table (EN-RT) serves a number of purposes, as follows:

- it provides a tabular summary of all the requirements;
- it shows the status of each EN-Requirement, whether it is essential to implement in all circumstances (Mandatory), or whether the requirement is dependent on the applicant having chosen to support a particular optional service or functionality (Optional). In particular it enables the EN-Requirements associated with a particular optional service or functionality to be grouped and identified;
- when completed in respect of a particular equipment it provides a means to undertake the static assessment of conformity with the EN.

The EN-RT is placed in an annex of the EN in order that it may be photocopied and used as a proforma.

Table A.1: EN Requirements Table (EN-RT)

EN Reference		EN 301 428				Comments
No.	Reference	EN-Requirements (Note 1)	Status for Tx-VSAT	Status for Rx-VSAT		
1	4.2.1	Off-axis spurious radiation	M	M		
2	4.2.2	On-axis spurious radiation	M			
3	4.2.3	Off-axis EIRP emission density within the band	M			
4	4.2.4	Carrier suppression	M			
5	4.2.5	Mechanical (antenna pointing)	M			
6	4.2.6.2	Control channels	M			
7	4.2.6.3.2	Processor monitoring	M			
8	4.2.6.3.3	Transmit subsystem monitoring	M			
9	4.2.6.3.4	VSAT transmission validation	M			
10	4.2.6.4	Reception of commands	M			
11	4.2.6.6	Power-on/Reset	M			

NOTE 1: These EN-Requirements are justified under Article 3.2 of the R&TTE Directive.

Key to columns:

No Table entry number;

Reference Subclause reference number of conformance requirement within the present document;

Status Status of the entry as follows:

M Mandatory, shall be implemented under all circumstances;

O Optional, may be provided, but if provided shall be implemented in accordance with the requirements;

Tx-VSAT Transmit-only VSAT or transmit and receive VSAT.

Rx-VSAT Receive-only VSAT.

Comments To be completed as required.

Annex B (informative): Pointing stability methodology

This test based on a numerical analysis shall be performed in two stages.

- a) In the first stage the effects of maximum wind speed shall be computed on the outdoor unit using a numerical analysis method (finite elements method by computer) taking into account the intrinsic properties of the materials.
- b) In the second stage the computed loads shall be applied to the structure.

The purpose of the numerical analysis is twofold:

- a) to show that the torque and the fields of force applied to the outdoor unit structure under nominated conditions do not reach the breakpoint limit of any element of the structure;
- b) to compute equivalent static loads (force and torque) applied to the critical attachment points of the structures, e.g.:
 - reflector - mounting legs fixing point;
 - reflector - struts;
 - LNB - struts.

Numerical analysis and load applications procedure:

- a) The air related parameters, namely the kinetic viscosity used to calculate drags at the rims of the structure shall be calculated with the standard atmospheric environmental conditions (temperature = 293 K, air pressure = $1,013 \times 10^5$ Pascal).
- b) The computations needed to derive the field of force and torque and the equivalent static stresses shall be carried out for each of the following variables:
 - elevation angle: maximum and minimum;
 - wind direction: in steps of 45° around the outdoor unit;
 - wind speed: 180 km/h.
- c) It shall be verified with the simulated results that break point limits are not exceeded for any self-contained element.
- d) The calculated equivalent static loads shall be applied at any identified critical fixing point of the assembly.
- e) Whilst the loads are applied the outdoor unit shall be observed and any distortion noted.
- f) The test report shall contain the following information:
 - the computation method used;
 - description of the test equipment;
 - description of the tests performed;
 - results of the safety margin test;
 - any signs of distortion observed;
 - results of the measurements of the deviation of the antenna position;
 - component deviation with respect to each other.

Bibliography

The following material, though not specifically referenced in the body of the present document, gives supporting information.

- ETS 300 157 (1996): "Satellite Earth Stations and Systems (SES); Receive-only Very Small Aperture Terminals (VSATs) operating in the 11/12 GHz frequency bands".
- ETS 300 159 (1996): "Satellite Earth Stations and Systems (SES); Transmit-only or transmit-and-receive Very Small Aperture Terminals (VSATs) used for communications operating in the Fixed Satellite Service (FSS) 11/12/14 GHz frequency bands".
- ETS 300 160 (1996): "Satellite Earth Stations and Systems (SES); Control and monitoring functions at a Very Small Aperture Terminal (VSAT)".
- ETS 300 161 (1996): "Satellite Earth Stations and Systems (SES); Centralized control and monitoring functions for Very Small Aperture Terminal (VSAT) networks".
- ETS 300 456 (1995): "Satellite Earth Stations and Systems (SES); Test methods for Very Small Aperture Terminals (VSATs) operating in the 11/12/14 GHz frequency bands".
- ETS 300 673 (1999): "Radio Equipment and Systems (RES); ElectroMagnetic Compatibility (EMC) standard for 4/6 GHz and 11/12/14 GHz Very Small Aperture Terminal (VSAT) equipment and 11/12/13/14 GHz Satellite News Gathering (SNG) Transportable Earth Station (TES) equipment".
- ETR 169 (1995): "Satellite Earth Stations and Systems (SES); Common Technical Regulations (CTRs) in the satellite earth station equipment field".
- EN 55022 (1994): "Satellite Earth Stations and Systems (SES); Network Control Facilities (NCF) for Land Mobile Earth Stations (LMES) operating in the 1,5/1,6 GHz bands and 11/12/14 GHz bands providing Low Bit Rate Data Communications (LBRDC)".

History

Document history			
V1.1.1	December 1999	One-step Approval Procedure	OAP 200017: 1999-12-29 to 2000-04-28