

**Satellite Earth Stations and Systems (SES);
Harmonized EN for
Low data rate Mobile satellite Earth Stations (MESs) except
aeronautical mobile satellite earth stations,
operating in the 11/12/14 GHz frequency bands
covering essential requirements
under article 3.2 of the R&TTE directive**



Reference

REN/SES-00062

Keywordsearthstation, LMES, MES, mobile, regulation,
satellite**ETSI**

650 Route des Lucioles
F-06921 Sophia Antipolis Cedex - FRANCE

Tel.: +33 4 92 94 42 00 Fax: +33 4 93 65 47 16

Siret N° 348 623 562 00017 - NAF 742 C
Association à but non lucratif enregistrée à la
Sous-Préfecture de Grasse (06) N° 7803/88

Important notice

Individual copies of the present document can be downloaded from:

<http://www.etsi.org>

The present document may be made available in more than one electronic version or in print. In any case of existing or perceived difference in contents between such versions, the reference version is the Portable Document Format (PDF). In case of dispute, the reference shall be the printing on ETSI printers of the PDF version kept on a specific network drive within ETSI Secretariat.

Users of the present document should be aware that the document may be subject to revision or change of status. Information on the current status of this and other ETSI documents is available at <http://www.etsi.org/tb/status/>

If you find errors in the present document, send your comment to:
editor@etsi.fr

Copyright Notification

No part may be reproduced except as authorized by written permission.
The copyright and the foregoing restriction extend to reproduction in all media.

© European Telecommunications Standards Institute 2001.
All rights reserved.

Contents

Intellectual Property Rights	6
Foreword	6
Introduction	7
1 Scope	9
2 References	10
3 Definitions and abbreviations	10
3.1 Definitions	10
3.2 Abbreviations	11
4 Technical requirement specifications	11
4.1 Environmental profile	11
4.2 Conformance requirements	11
4.2.1 Unwanted emissions outside the band	11
4.2.1.1 Justification	11
4.2.1.2 Specification	11
4.2.1.3 Conformance tests	12
4.2.2 Unwanted emissions within the band	12
4.2.2.1 Justification	12
4.2.2.2 Specification	12
4.2.2.3 Conformance tests	12
4.2.3 Off-axis EIRP emissions density in the nominated bandwidth	13
4.2.3.1 Justification	13
4.2.3.2 Specification	13
4.2.3.3 Conformance tests	13
4.2.4 Control and Monitoring Functions (CMF)	13
4.2.4.1 Processor monitoring	13
4.2.4.1.1 Justification	13
4.2.4.1.2 Specification	14
4.2.4.1.3 Conformance tests	14
4.2.4.2 Transmit subsystem monitoring	14
4.2.4.2.1 Justification	14
4.2.4.2.2 Specification	14
4.2.4.2.3 Conformance tests	14
4.2.4.3 Power-on/Reset	14
4.2.4.3.1 Justification	14
4.2.4.3.2 Specification	14
4.2.4.3.3 Conformance tests	14
4.2.4.4 Control Channel (CC) reception	14
4.2.4.4.1 Justification	14
4.2.4.4.2 Specification	15
4.2.4.4.3 Conformance tests	15
4.2.4.5 Network control commands	15
4.2.4.5.1 Justification	15
4.2.4.5.2 Specification	15
4.2.4.5.3 Conformance tests	15
4.2.4.6 Initial burst transmission	15
4.2.4.6.1 Justification	15
4.2.4.6.2 Specification	16
4.2.4.6.3 Conformance tests	16
5 Testing for compliance with technical requirements	16
5.1 Environmental conditions for testing	16
5.2 Essential radio test suites	16
6 Test methods	16

6.1	Unwanted emissions outside the band 14,00 GHz to 14,25 GHz	17
6.1.1	General	17
6.1.2	Test site	17
6.1.3	Test method	18
6.1.3.1	Receive test equipment	18
6.1.3.1.1	Measuring receiver for measurements up to 1 000 MHz	18
6.1.3.1.2	Spectrum analyser for measurements above 1 000 MHz	18
6.1.4	Procedure	19
6.1.4.1	Test arrangements	19
6.1.4.2	Up to 1 000 MHz	20
6.1.4.3	Above 1 000 MHz	20
6.1.4.3.1	Identification of the significant frequencies of the radiated unwanted emissions	21
6.1.4.3.2	Measurement of radiated power levels of identified spurious radiation	22
6.1.4.3.3	Measurement of conducted unwanted emissions at the antenna flange	23
6.1.4.3.3.1	Test site	23
6.1.4.3.3.2	Procedure	23
6.2	Unwanted emissions within the band 14,00 GHz to 14,25 GHz	24
6.2.1	Test method	24
6.2.1.1	General	24
6.2.1.2	Method of measurement at the antenna flange	24
6.2.1.3	Method of measurement with a test antenna	25
6.3	Off-axis EIRP emissions density in the nominated bandwidth	26
6.3.1	General	26
6.3.2	Static rms antenna pointing accuracy	26
6.3.2.1	Method of measurement	26
6.3.3	Measurement of the off-axis EIRP without the antenna	27
6.3.3.1	Transmitter output power density	27
6.3.3.1.1	Method of measurement	28
6.3.3.2	Antenna transmit gain	28
6.3.3.2.1	General	28
6.3.3.2.2	Test site	28
6.3.3.2.3	Method of measurement	28
6.3.3.3	Antenna transmit radiation patterns	30
6.3.3.3.1	General	30
6.3.3.3.2	Test site	30
6.3.3.3.3	Method of measurement	30
6.3.3.4	Computation of results	31
6.3.4	Measurement of the off-axis EIRP with the antenna	31
6.3.4.1	General	31
6.3.4.2	Maximum EIRP density per 40 kHz ratio relative to the EIRP	31
6.3.4.2.1	Method of measurement	31
6.3.4.3	Maximum on-axis EIRP	32
6.3.4.3.1	General	32
6.3.4.3.2	Test site	32
6.3.4.3.3	Method of measurement	32
6.3.4.4	Antenna transmit radiation patterns	33
6.3.4.4.1	General	33
6.3.4.4.2	Test site	34
6.3.4.4.3	Method of measurement	34
6.3.4.5	Computation of results	35
6.4	Control and monitoring	35
6.4.1	Test arrangement	35
6.4.2	Processor monitoring	36
6.4.2.1	Test method	36
6.4.3	Transmit subsystem monitoring	36
6.4.3.1	Test method	36
6.4.4	Power-on/Reset	36
6.4.4.1	Test method	36
6.4.5	Control Channel (CC) reception	37
6.4.5.1	Test method	37
6.4.6	Network control commands	38
6.4.6.1	Test method	38

6.4.7	Initial burst transmission	39
6.4.7.1	Test method.....	39
Annex A (normative):	The EN Requirements Table (EN-RT).....	40
Annex B (informative):	Bibliography.....	42
History		43

Intellectual Property Rights

IPRs essential or potentially essential to the present document may have been declared to ETSI. The information pertaining to these essential IPRs, if any, is publicly available for **ETSI members and non-members**, and can be found in ETSI SR 000 314: "*Intellectual Property Rights (IPRs); Essential, or potentially Essential, IPRs notified to ETSI in respect of ETSI standards*", which is available from the ETSI Secretariat. Latest updates are available on the ETSI Web server (<http://www.etsi.org/ipr>).

Pursuant to the ETSI IPR Policy, no investigation, including IPR searches, has been carried out by ETSI. No guarantee can be given as to the existence of other IPRs not referenced in ETSI SR 000 314 (or the updates on the ETSI Web server) which are, or may be, or may become, essential to the present document.

Foreword

This Candidate Harmonized European Standard (Telecommunications series) has been produced by ETSI Technical Committee Satellite Earth Stations and Systems (SES), and is now submitted for the ETSI standards One-step Approval Procedure.

The present document has been produced by ETSI in response to a mandate from the European Commission issued under Council Directive 98/34/EC (as amended) laying down a procedure for the provision of information in the field of technical standards and regulations.

The present document is intended to become a Harmonized Standard, the reference of which will be published in the Official Journal of the European Communities referencing the Directive 1999/5/EC of the European Parliament and of the Council of 9 March 1999 on radio equipment and telecommunications terminal equipment and the mutual recognition of their conformity ("the R&TTE Directive") [1].

Proposed national transposition dates	
Date of latest announcement of this EN (doa):	3 months after ETSI publication
Date of latest publication of new National Standard or endorsement of this EN (dop/e):	6 months after doa
Date of withdrawal of any conflicting National Standard (dow):	18 months after doa

Introduction

The present document is part of a set of standards designed to fit in a modular structure to cover all radio and telecommunications terminal equipment under the R&TTE Directive [1]. Each standard is a module in the structure. The modular structure is shown in figure 1.

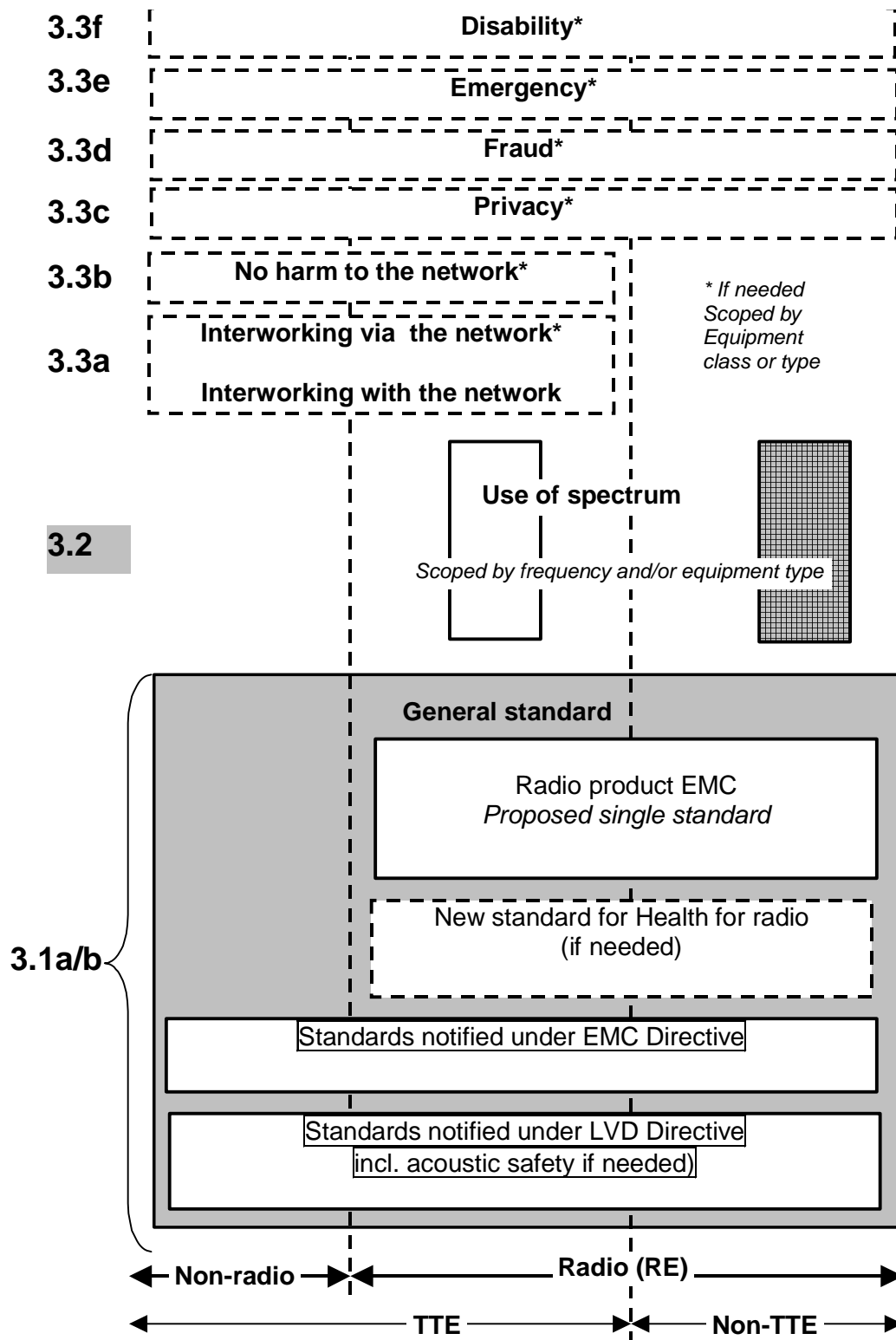

Figure 1: Modular structure for the various standards used under the R&TTE Directive

The left hand edge of the figure shows the different clauses of article 3 of the Directive. The essential requirements under article 3.1a (safety etc.) and 3.1b (EMC) are addressed by a single General Standard that applies to all equipment (SR 001 470). The General Standard makes general cross references to those standards already notified under the LVD and EMC Directives that are appropriate for radio equipment and telecommunications terminal equipment and so provides a link to the arrangements under those directives thus avoiding duplication of notifications with potential problems of notifications not being synchronized.

The vertical boxes show the standards under article 3.2 for the use of the radio spectrum. The scopes of these standards are specified either by frequency (normally in the case where frequency bands are harmonized) or by radio equipment type.

For article 3.3 various horizontal boxes are shown. Their dotted lines indicate that essential requirements in these areas have to be adopted by the Commission. If such essential requirements are adopted, and as far and as long as they are applicable, they will justify individual standards whose scope is likely to be specified by function or interface type.

The bottom of the figure shows the relationship of the standards to radio equipment and telecommunications terminal equipment. A particular equipment may be radio equipment, telecommunications terminal equipment or both. The General Standard will always apply to it, and a radio spectrum standard will apply if it is radio equipment. An article 3.3 standard will apply as well only if the relevant essential requirement is adopted by the Commission and if the equipment in question lies within the scope of the corresponding standard. Thus, depending on the nature of the equipment, the essential requirements under the Directive may be covered in just the General Standard or in a set of standards that includes the General Standard.

The modularity principle has been taken because:

- it minimizes the number of standards needed. Because equipment may, in fact, have multiple interfaces and functions it is not practicable to produce a single standard for each possible combination of functions that may occur in an equipment;
- it provides scope for standards under articles 3.2 and 3.3 to be added when new frequency bands are agreed or when the Commission takes decisions under article 3 without requiring alteration of standards that are already published.

It clarifies, simplifies and promotes the usage of Harmonized Standards as the relevant means of conformity assessment.

The present document has been produced by the Satellite Earth Stations and Systems (SES) Technical Committee of the European Telecommunications Standards Institute (ETSI).

The present document is based on TBR 027 (see Bibliography).

The requirements have been selected to ensure an adequate level of compatibility with other radio services. The levels, however, do not cover extreme cases which may occur in any location but with a low probability of occurrence.

The present document may not cover those cases where a potential source of interference which is producing individually repeated transient phenomena or a continuous phenomenon is present, e.g. a radar or broadcast site in the near vicinity. In such a case it may be necessary to use special protection applied to either the source of interference, or the interfered part or both.

The present document does not contain any requirement, recommendation or information about the installation of the MES.

The determination of the parameters of the user earth stations using a given geo-stationary satellite for the protection of the spectrum allocated to that satellite, is considered to be under the responsibility of the satellite operator or the satellite network operators.

1 Scope

The present document applies to Mobile Earth Stations (MESs), except aeronautical mobile earth stations, which have the following characteristics:

- The MES are operating in one or more frequency ranges of the Fixed Satellite Service (FSS):
 - 10,70 GHz to 11,70 GHz (space to earth);
 - 12,50 GHz to 12,75 GHz (space to earth);
 - 14,00 GHz to 14,25 GHz (earth to space).

Because the transmissions from the MES to the Satellite in the 14,00 GHz to 14,25 GHz band fall under a secondary allocation, the transmissions should not cause harmful interference to primary services (e.g. the Fixed Satellite Service (FSS)) and at the same time cannot claim protection from harmful interference from those services.

- The MES may be either:
 - a Land Mobile Earth Station (LMES) radio equipment; and/or
 - a Maritime Mobile Earth Station (MMES) radio equipment not providing those distress and safety functions required by the International Maritime Organization (IMO).
- These LMESs could be either vehicle mounted or portable equipment.
- These MMESs are installable equipment on ships.
- The MES could consist of a number of modules including a keyboard interface to the user.
- The MES use linear polarization.
- The MES operate through a geostationary satellite at least 3° away from any other geostationary satellite operating in the same frequency band and covering the same area.
- The antenna of the MES may be omnidirectional or directional with a means of tracking the satellite.
- The MES are operating as part of a satellite network used for the distribution and/or exchange of information between users.
- The MES are controlled and monitored by a Network Control Facility (NCF). The NCF is outside the scope of the present document.

The present document applies to the MES with its ancillary equipment and its various terrestrial ports, and when operated within the boundary limits of the operational environmental profile declared by the manufacturer.

The present document is intended to cover the provisions of Directive 1999/5/EC (R&TTE Directive) [1] article 3.2, which states that "... radio equipment shall be so constructed that it effectively uses the spectrum allocated to terrestrial/space radio communications and orbital resources so as to avoid harmful interference".

In addition to the present document, other ENs that specify technical requirements in respect of essential requirements under other parts of article 3 of the R&TTE Directive [1] may apply to equipment within the scope of the present document.

NOTE: A list of such ENs is included on the ETSI web site.

2 References

The following documents contain provisions which, through reference in this text, constitute provisions of the present document.

- References are either specific (identified by date of publication and/or edition number or version number) or non-specific.
- For a specific reference, subsequent revisions do not apply.
- For a non-specific reference, the latest version applies.

- [1] Directive 1999/5/EC of the European Parliament and of the Council of 9 March 1999 on radio equipment and telecommunications terminal equipment and the mutual recognition of their conformity.
- [2] CISPR 16-1: "Specification for radio disturbance and immunity measuring apparatus and methods; Part 1: Radio disturbance and immunity measuring apparatus".

3 Definitions and abbreviations

3.1 Definitions

For the purposes of the present document, the terms and definitions given in the R&TTE Directive and the following apply:

carrier-off state: MES is in this state when either it is authorized by the Network Control Facility (NCF) to transmit but when it does not transmit any signal, or when it is not authorized by the NCF to transmit.

carrier-on state: MES is in this state when it is authorized by the NCF to transmit and when it transmits a signal.

Control Channel (CC): channel or channels by which MES receive control information from the NCF of their network

environmental profile: range of environmental conditions under which equipment within the scope of the present document is required to comply with the provisions of the present document

Externally Mounted Equipment (EME): EME consists of those of the modules of the Installable Equipment (IE) which are intended to be mounted externally to the vehicle as stated by the manufacturer

Installable Equipment (IE): equipment which is intended to be fitted to a vehicle
An IE may consist of one or several interconnected modules.

Internally Mounted Equipment (IME): Those of the modules of the IE which are not declared by the manufacturer as EME are defined as IME.

manufacturer: The manufacturer, his authorized representative within the Community or the person responsible for placing the apparatus on the market.

nominated bandwidth: the bandwidth of the MES radio frequency transmission is nominated by the manufacturer. The nominated bandwidth is wide enough to encompass all spectral elements of the transmission which have a level greater than the specified unwanted emissions limits. The nominated bandwidth is wide enough to take account of the transmit carrier frequency stability. The nominated bandwidth is within the transmit frequency band within which the MES operates.

Portable Equipment (PE): is generally intended to be self-contained, free standing and portable. Normally, a PE would consist of a single module, but may consist of several interconnected modules.

unwanted emissions: emissions falling outside the nominated bandwidth

3.2 Abbreviations

For the purposes of the present document, the following abbreviations apply:

CC	Control Channel
CMF	Control and Monitoring Functions
EIRP	Equivalent Isotropically Radiated Power
EME	Externally Mounted Equipment
EUT	Equipment Under Test
IE	Installable Equipment
IME	Internally Mounted Equipment
LMES	Land Mobile Earth Station
MES	Mobile Earth Station
MMES	Maritime Mobile Earth Station
NCF	Network Control Facility
PE	Portable Equipment
RF	Radio Frequency
rms	root mean square
R&TTE	Radio and Telecommunications Terminal Equipment
STE	Special Test Equipment

4 Technical requirement specifications

4.1 Environmental profile

The technical requirements of the present document apply under the environmental profile for operation of the equipment, which shall be declared by the manufacturer. The equipment shall comply with all the technical requirements of the present document at all times when operating within the boundary limits of the declared operational environmental profile.

The environmental profile for operation of the equipment shall include the ranges of humidity, temperature and supply voltage.

4.2 Conformance requirements

4.2.1 Unwanted emissions outside the band

4.2.1.1 Justification

Protection of terrestrial and satellite services from emissions caused by MES outside the band 14,00 GHz to 14,25 GHz.

4.2.1.2 Specification

The unwanted emissions in the measurement bandwidth and in all directions from the MES outside the band 14,00 GHz to 14,25 GHz, within which the MES is designed to operate, shall be below the following limits:

- 1) The unwanted emissions over the frequency range 30 MHz to 1 000 MHz shall not exceed the limits in table 1a for LMESs and table 1b for MMESs.

Table 1a: Limits of LMESs unwanted emissions up to 1 000 MHz at a measuring distance of 10 m in a 120 kHz bandwidth

Frequency (MHz)	Quasi-peak limits (dB(μV/m))
30 to 230	30
230 to 1 000	37

Table 1b: Limits of MMESs unwanted emissions up to 1 000 MHz at a measuring distance of 10 m in a 120 kHz bandwidth

Frequency (MHz)	Quasi-peak limits (dB(µV/m))
30 to 156	30
156 to 165	14 (see note)
165 to 230	30
230 to 1 000	37
NOTE: In the band 156 MHz to 165 MHz, a 9 kHz bandwidth apply.	

The lower limit shall apply at the transition frequency.

- 2) The unwanted emissions Equivalent Isotropically Radiated Power (EIRP) above 1 000 MHz, in the measurement bandwidth and in all directions shall not exceed the limits given in table 2.

Table 2: Limits of unwanted emissions above 1 000 MHz and outside the band 14,00 GHz to 14,25 GHz

Frequency range (MHz)	Carrier-on		Carrier-off	
	EIRP limit (dBpW)	Measurement bandwidth (kHz)	EIRP limit (dBpW)	Measurement bandwidth (kHz)
1 000 - 1 525	49	100	48	100
1 525 - 1 559	49	100	17	3
1 559 - 3 400	49	100	48	100
3 400 - 10 700	55	100	48	100
10 700 - 21 200	61	100	54	100
21 200 - 40 000	67	100	60	100

The lower limits shall apply at the transition frequencies.

4.2.1.3 Conformance tests

Conformance tests shall be carried out in accordance with clause 6.1.

4.2.2 Unwanted emissions within the band

4.2.2.1 Justification

Protection of the primary services operating in the 14,00 GHz to 14,25 GHz frequency band.

4.2.2.2 Specification

Specification 1: Carrier-on state

The EIRP spectral density of the unwanted emissions shall not exceed $4 - 10 \log N$ dBW/100 kHz in the 14,00 GHz to 14,25 GHz band and outside the nominated bandwidth.

N is the maximum number of MES which are expected to transmit simultaneously on the same frequency. This number shall not be exceeded for more than 0,01 % of the time. The value of N and the operational conditions of the system shall be declared by the manufacturer.

Specification 2: Carrier-off state

The EIRP spectral density of any emission in the 14,00 GHz to 14,25 GHz band shall not exceed -21 dBW/100 kHz.

4.2.2.3 Conformance tests

Conformance tests shall be carried out in accordance with clause 6.2.

4.2.3 Off-axis EIRP emissions density in the nominated bandwidth

4.2.3.1 Justification

Protection of other satellite systems which use the same frequency band.

4.2.3.2 Specification

For directional antennas the maximum EIRP in any 40 kHz band from any MES in any direction ϕ degrees from the antenna main beam axis shall not exceed the following limits within 3° of the geostationary orbit:

$33 - 25 \log(\phi + \delta\phi) - 10 \log(K)$	dBW/40 kHz where	$2,5^\circ$	$\leq \phi + \delta\phi \leq 7,0^\circ$;
$+12 - 10 \log(K)$	dBW/40 kHz where	$7,0^\circ$	$< \phi + \delta\phi \leq 9,2^\circ$;
$36 - 25 \log(\phi + \delta\phi) - 10 \log(K)$	dBW/40 kHz where	$9,2^\circ$	$< \phi + \delta\phi \leq 48^\circ$;
$-6 - 10 \log(K)$	dBW/40 kHz where	48°	$< \phi + \delta\phi \leq 180^\circ$;

where ϕ is the angle, in degrees, between the main beam axis and the direction considered. The value of $\delta\phi$ is equal to either:

- the rms antenna tracking accuracy; or
- twice the static rms antenna pointing accuracy; whichever is the larger.

K is the power density ratio between the fully loaded system and a single MES measured in a 40 kHz bandwidth.

The value of K, all technical characteristics and the operational conditions declared by the manufacturer shall be entered in the test report.

These limits apply over the range of latitudes and for the geostationary orbital arc declared by the manufacturer.

For non-directional antennas, the maximum EIRP per 40 kHz in any direction shall not exceed:

$$-6 - 10 \log(K) \text{ dBW/40 kHz};$$

where K is as defined above.

4.2.3.3 Conformance tests

Conformance tests shall be carried out in accordance with clause 6.3.

4.2.4 Control and Monitoring Functions (CMF)

The following minimum set of CMF shall be implemented in MES in order to minimize the probability that they may originate unwanted transmissions that may give rise to harmful interference to other systems.

Under any fault condition when the MES transmissions are being suppressed the limits for carrier-off state shall apply.

4.2.4.1 Processor monitoring

4.2.4.1.1 Justification

To ensure that the MES can suppress transmissions in the event of a processor sub-system failure.

4.2.4.1.2 Specification

The MES shall incorporate a processor monitoring function for each of its processors involved in the manipulation of traffic and in control and monitoring functions.

The processor monitoring function shall detect any failure of the processor hardware and software.

No later than one second after any fault condition occurs, the MES shall enter the carrier-off state until the processor monitoring function has determined that all fault conditions have been cleared.

4.2.4.1.3 Conformance tests

Conformance tests shall be carried out in accordance with clause 6.4.

4.2.4.2 Transmit subsystem monitoring

4.2.4.2.1 Justification

To ensure the correct operation of the transmit frequency generation sub-system, and to inhibit transmissions should the sub-system fail.

4.2.4.2.2 Specification

The MES shall monitor the operation of its transmit frequency generation sub-system.

No later than 5 seconds after any fault condition of the transmit frequency generation sub-system occurs, the MES shall enter the carrier-off state until the transmit sub-system monitoring function has determined that all fault conditions have been cleared.

4.2.4.2.3 Conformance tests

Conformance tests shall be carried out in accordance with clause 6.4.

4.2.4.3 Power-on/Reset

4.2.4.3.1 Justification

To demonstrate that the MES achieves a controlled non-transmitting state following the powering of the unit or the occurrence of a reset made by a local operator when this function is implemented.

4.2.4.3.2 Specification

During and following "power on" or a manual reset when this function is implemented, the MES shall remain in the carrier-off state.

4.2.4.3.3 Conformance tests

Conformance tests shall be carried out in accordance with clause 6.4.

4.2.4.4 Control Channel (CC) reception

4.2.4.4.1 Justification

To ensure that the MES cannot transmit unless it correctly receives the CC messages from the NCF.

4.2.4.4.2 Specification

- a) Without correct reception of the CC messages from the NCF, the MES shall remain in the carrier-off state.
- b) The MES shall enter the carrier-off state immediately after a period not exceeding 30 seconds without correct reception of the CC messages from the NCF.

4.2.4.4.3 Conformance tests

Conformance tests shall be carried out in accordance with clause 6.4.

4.2.4.5 Network control commands

4.2.4.5.1 Justification

These requirements ensure that the MES is capable of:

- a) retaining a unique identification in the network and transmitting it upon reception of an appropriate request;
- b) receiving commands from the NCF through its CC and executing those commands.

4.2.4.5.2 Specification

The MES shall hold, in non-volatile memory, its unique identification code in the network.

The MES shall be capable of receiving through its CC dedicated commands (addressed to the MES) from the NCF, and which contain:

- transmission enable commands;
- transmission disable commands;
- identification request.

Once a transmission enable command is received the MES is authorized to transmit.

After power-on or reset the MES shall remain in the carrier-off state until it receives a transmission enable command. For systems where no transmission enable command is expected after power-on or reset the MES may only transmit initial bursts (see clause 4.2.4.6).

Once a transmission disable command is received, within 1 second the MES shall enter and shall remain in the carrier-off state until the transmission disable command is superseded by a subsequent transmission enable command.

The MES shall be capable of transmitting its identification code upon reception of an identification request.

4.2.4.5.3 Conformance tests

Conformance tests shall be carried out in accordance with clause 6.4.

4.2.4.6 Initial burst transmission

4.2.4.6.1 Justification

To limit disturbance to other services.

4.2.4.6.2 Specification

For systems where no transmission enable command is expected after power-on or reset the MES may transmit initial bursts:

- a) the transmission of the initial burst shall not exceed 1 % of the time;
- b) each burst shall not last more than one second.

4.2.4.6.3 Conformance tests

Conformance tests shall be carried out in accordance with clause 6.4.7.

5 Testing for compliance with technical requirements

5.1 Environmental conditions for testing

Tests defined in the present document shall be carried out at representative points within the boundary limits of the declared operational environmental profile.

5.2 Essential radio test suites

The essential radio test suites for a MES are given in clause 6 .

6 Test methods

The values of measurement uncertainty associated with each measurement parameter apply to all of the test cases described in the present document. The measurement uncertainties shall not exceed the values shown in table 3.

Table 3: Measurement uncertainty

Measurement parameter	Uncertainty
RF frequency	±10 kHz
RF power	±0,75 dB
Conducted spurious	±4 dB
Antenna gain	±2 dB
Radiated spurious	±6 dB

To enable the performance tests to be carried out the use of Special Test Equipment (STE), made available by the manufacturer, may be necessary. Since this test equipment will be specific for the particular system, it is not possible to provide detailed specifications in the present document. However, the following baseline is provided:

- if the MES requires to receive a modulated carrier from the satellite in order to transmit, then special test arrangements are required to simulate the satellite signal, thus enabling the MES to transmit allowing measurement of transmission parameters;
- any characteristic of these special test arrangements which may have direct or indirect effects on the parameters to be measured shall be clearly stated by the manufacturer.

All tests with carrier-on shall be undertaken with the transmitter operating at full power and with the maximum transmit burst rate where applicable.

All technical characteristics and operational conditions declared by the manufacturer shall be entered in the test report.

6.1 Unwanted emissions outside the band 14,00 GHz to 14,25 GHz

6.1.1 General

For purpose of the test, the Equipment Under Test (EUT) comprises:

a) for IE:

- the EME;
- the IME;
- interconnecting cables between IME and EME units as supplied by the manufacturer;
- the necessary power supply cables and any other cable ensuring a proper functioning of the terminal.

b) for PE:

- for a single module PE, the module itself with any deployable parts in their normal operating configuration;
- for a multiple module PE, all such modules with all necessary interconnecting cables of lengths as normally supplied by the manufacturer; again any deployable parts should be in their normal operating configuration.

For measurements up to 1 000 MHz the distance between the EUT and the measuring antenna shall be 10 m. For measurements above 1 000 MHz the distance between the EUT or the substitution antenna and the measuring antenna shall be such that the radiating near-field of each antenna shall not overlap with that of the other. The larger radiating near-field of the EUT and substitution antenna shall be used to determine the minimum distance between the EUT and measuring antenna in the first instance.

The upper and lower extremes of the tuning range shall be stated by the manufacturer.

6.1.2 Test site

The test shall be performed either in an open area test site, a semi-anechoic chamber or an anechoic chamber. Ambient noise levels shall be at least 6 dB below the applicable unwanted emissions limit.

An open area test site shall be flat, free of overhead wires and nearby reflecting structures, sufficiently large to permit aerial placement at the specified measuring distance and provide adequate separation between aerial, test unit and reflecting structures.

A metal ground plane shall be inserted on the natural ground plane and it shall extend at least 1 m beyond the perimeter of the EUT at one end and at least 1 m beyond the measurement antenna at the other end.

6.1.3 Test method

For IE, the EUT shall be installed with a separation of about 0,5 m between the IME and the EME, the maximum length connection cable specified by the manufacturer shall be installed. The height of the cable shall be between 0,5 m and 1 m. The cable shall be maintained in that position by non-metallic means. The EME shall be set, in its normal operating configuration on a non-metallic table at a height between 0,5 m and 1 m. The IME shall be set on a non-metallic table at a height of 0,8 m for tests up to 1 000 MHz and between 0,5 m and 1 m for tests above 1 000 MHz. Any associated equipment, e.g. portable computer or data terminal if required for operation of the MES, shall be placed next to, and at the same height as, the IME.

For PE, the equipment shall be arranged in its normal operating configuration as recommended by the manufacturer on a non-metallic table at a height between 0,5 m and 1 m.

The EUT shall be terminated with matched impedances at the terrestrial ports if recommended by the manufacturer in the user documentation and if there is no associated equipment connected to such ports.

For frequencies up to 80 MHz, the measuring antenna shall be a balanced dipole which has a length equal to the 80 MHz resonant length and shall be matched to the feeder by a suitable transforming device. Measurements with broad band antennas is also possible provided that the test site has been calibrated according to the requirements of CISPR 16-1 [2].

For frequencies between 80 MHz and 1 000 MHz, the measuring antenna shall be a balanced dipole which shall be resonant in length. Measurements with broad band antennas is also possible provided that the test site has been calibrated according to the requirements of CISPR 16-1 [2].

For frequencies above 1 000 MHz, the antenna shall be a horn radiator of known gain/frequency characteristics. When used for reception, the antenna and any associated amplification system shall have an amplitude/frequency response within ± 2 dB of the combined calibration curves across the measurement frequency range considered for the antenna. The antenna is mounted on a support capable of allowing the antenna to be used in either horizontal or vertical polarization and at the specified height.

For tests up to 1 000 MHz, the receive test equipment shall be a measuring receiver.

For tests above 1 000 MHz, the receive test equipment shall be a spectrum analyser.

6.1.3.1 Receive test equipment

6.1.3.1.1 Measuring receiver for measurements up to 1 000 MHz

Measuring receivers shall conform to the following characteristics:

- the response to a constant amplitude sine wave signal shall remain within ± 1 dB across the frequency range of interest;
- quasi-peak detection shall be used in a -6 dB bandwidth of 120 kHz;
- the receiver shall be operated at more than 1 dB below the compression point during tests/measurements.

6.1.3.1.2 Spectrum analyser for measurements above 1 000 MHz

The spectrum analyser resolution bandwidth shall be set to the specified measuring bandwidth or as close as possible. If the resolution bandwidth is different from the specified measuring bandwidth, bandwidth correction shall be performed for noise-like wideband signals. The measuring system shall be capable of detecting signals at least 6 dB below the applicable unwanted emissions limit.

6.1.4 Procedure

6.1.4.1 Test arrangements

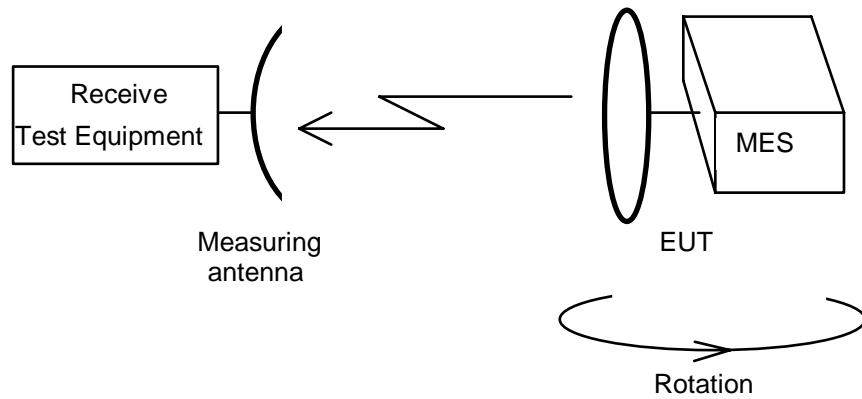

Figure 2: Test arrangement - unwanted emissions measurement, first axis

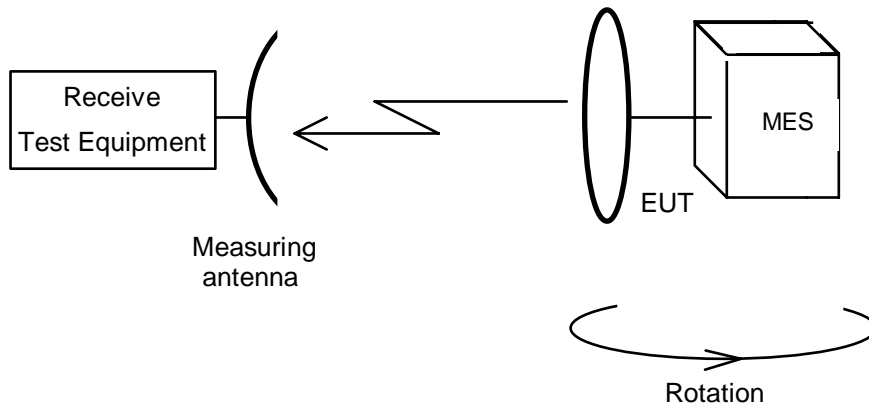

Figure 3: Test arrangement - unwanted emissions measurement, second axis

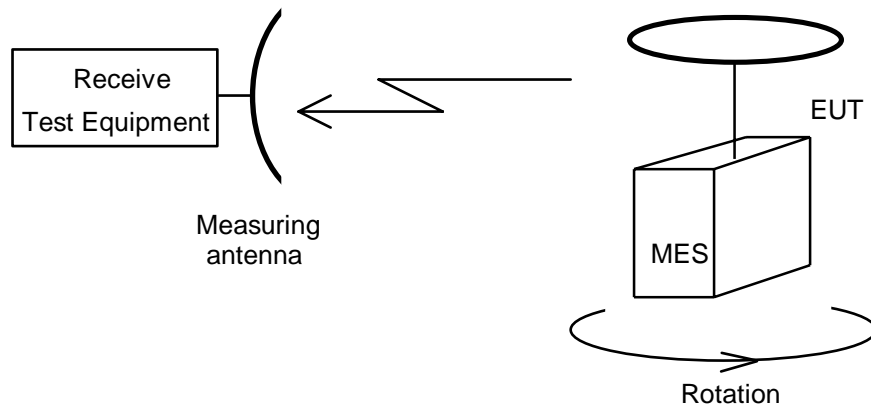

Figure 4: Test arrangement - unwanted emissions measurement, third axis

6.1.4.2 Up to 1 000 MHz

- a) The test arrangement shall be as shown in figure 2 with the measuring receiver installed. EUTs with adjustable antennas shall have the antenna boresight axis in the plane of rotation. The measuring antenna boresight axis shall coincide with the plane of rotation of the boresight of the EUT.
- b) The EUT shall be in the carrier-on state with the carrier at the lowest possible centre frequency.
- c) The EUT shall be rotated through 360° whilst unwanted emissions are measured in frequency and amplitude, over the frequency range 30 MHz to 1 000 MHz. The frequency and amplitude of each signal shall be noted.
- d) The measurements shall be repeated with the measuring antenna in the opposite polarization and the signal levels similarly noted.
- e) The tests in c) and d) above shall be repeated with the EUT carrier at the highest possible centre frequency.
- f) The tests in c) and d) above shall be repeated with the carrier-off.
- g) The tests in b) to f) above shall be repeated with the EUT turned so that its axis of rotation is orthogonal to that of the first case, as shown in figure 3. The EUT antenna boresight axis shall remain in the plane of rotation.
- h) The tests in b) to f) above shall be repeated with the EUT turned so that its axis of rotation is mutually orthogonal to those of the first two cases, as shown in figure 4. The EUT antenna boresight axis shall be perpendicular to the plane of rotation.

6.1.4.3 Above 1 000 MHz

For MES equipment for which measurements at the antenna flange are not possible or not agreed by the manufacturer, the EUT shall be tested with the antenna. The test shall be performed in two stages:

- procedure a): identification of the significant frequencies of the radiated unwanted emissions;
- procedure b): measurement of radiated power levels of identified unwanted emissions.

For MES equipment for which measurements at the antenna flange are possible and agreed by the manufacturer, the EUT shall be tested without the antenna. The test shall be performed in three stages:

- procedure a): identification of the significant frequencies of the radiated unwanted emissions;
- procedure b): measurement of radiated power levels of identified unwanted emissions;
- procedure c): measurement of conducted unwanted emissions.

6.1.4.3.1 Identification of the significant frequencies of the radiated unwanted emissions

- a) The test arrangement shall be as shown in figure 2 with the spectrum analyser installed. EUTs with adjustable antennas shall have the antenna boresight axis in the plane of rotation. The measuring antenna boresight axis shall coincide with the plane of rotation of the boresight of the EUT.
- b) The EUT shall be in the carrier-on state with the carrier at the lowest possible centre frequency.
- c) The EUT shall be rotated through 360° whilst unwanted emissions are measured in frequency and amplitude, over the frequency range 1 000 MHz to 40 GHz. The frequency and amplitude of each signal shall be noted.
- d) The measurements shall be repeated with the measuring antenna in the opposite polarization and the signal levels similarly noted.
- e) The tests in c) and d) above shall be repeated with the EUT carrier at the highest possible centre frequency.
- f) The tests in c) and d) above shall be repeated with the carrier-off.
- g) The tests in b) to f) above shall be repeated with the EUT turned so that its axis of rotation is orthogonal to that of the first case, as shown in figure 3. The EUT antenna boresight axis shall remain in the plane of rotation.
- h) The tests in b) to f) above shall be repeated with the EUT turned so that its axis of rotation is mutually orthogonal to those of the first two cases, as shown in figure 4. The EUT antenna boresight axis shall be perpendicular to the plane of rotation.

6.1.4.3.2 Measurement of radiated power levels of identified spurious radiation

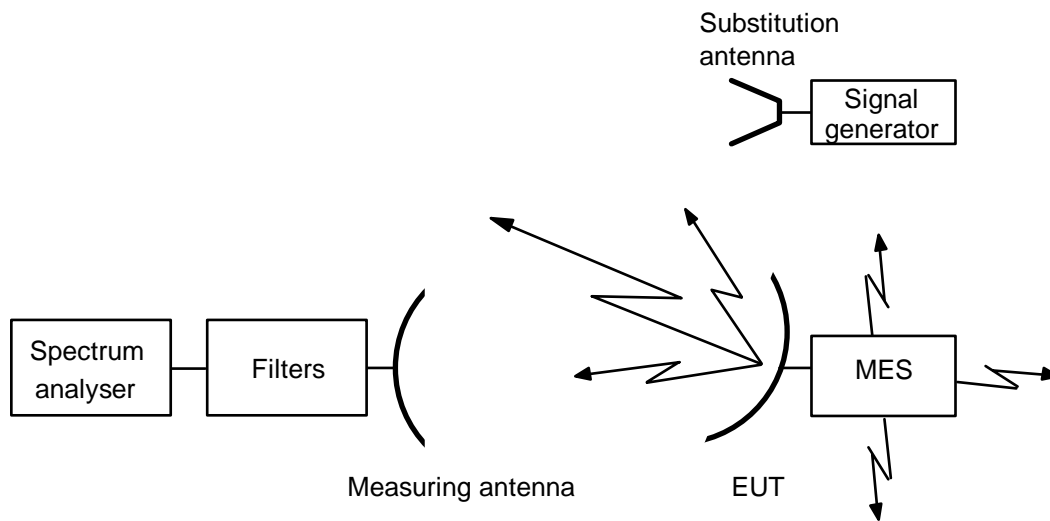

Figure 5: Test arrangement - unwanted emissions measurement for an EUT with antenna

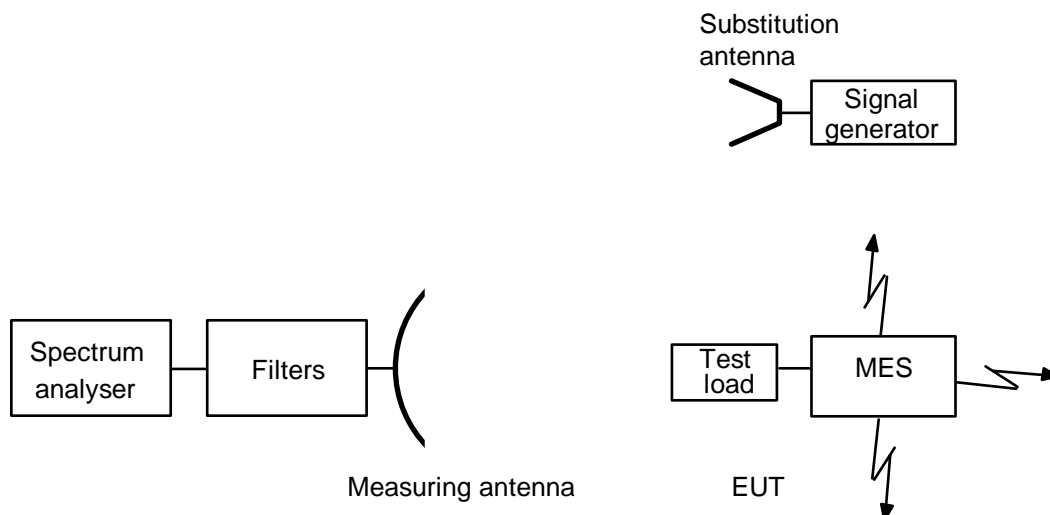

Figure 6: Test arrangement - unwanted emissions measurement for an EUT without antenna

- a) The test arrangement shall be as shown in figures 5 or 6.
- b) The EUT shall be in the carrier-on state with the modulated carrier centre frequency as appropriate to the previously identified unwanted emission.
- c) The measuring antenna shall be adjusted in height and the EUT rotated for a maximum response on the associated spectrum analyser at each unwanted emission previously identified, this response level shall be noted.
- d) For the test arrangement in figure 2 the investigation shall be repeated with the measuring antenna in the opposite polarization and the response level similarly noted.
- e) The EUT shall be replaced by the substitution antenna to which is connected a signal generator. The main beam axes of the measuring and substitution antennas shall be aligned.
- f) The substitution and measuring antennas shall be aligned in the polarization which produced the larger response between the EUT and the test antenna, in steps c) and d).

- g) The output of the generator shall be adjusted so that the received level is identical to that of the previously noted largest spurious radiation.
- h) The output level of the signal generator shall be noted. The EIRP of the unwanted emission is the sum, in dB, of the signal generator output plus the substitution antenna isotropic gain minus the interconnection cable loss.

6.1.4.3.3 Measurement of conducted unwanted emissions at the antenna flange

6.1.4.3.3.1 Test site

There are no requirements for the test site to be used for this test.

6.1.4.3.3.2 Procedure

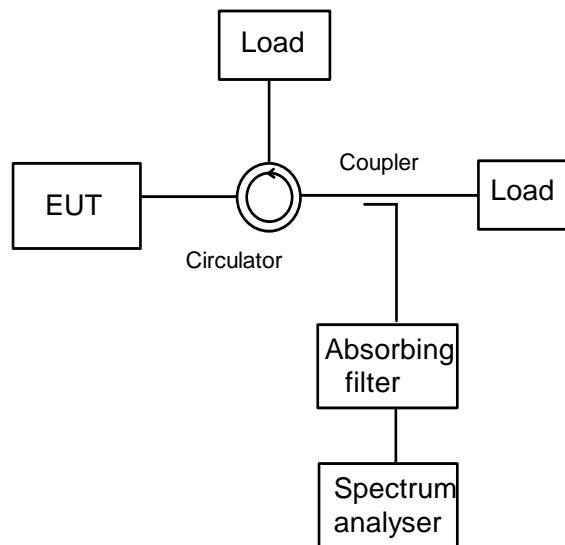

Figure 7: Test arrangement - conducted unwanted emissions

- a) The test arrangement shall be as shown in figure 7. The absorbing filter shall be tuned to the transmit carrier frequency, in order to protect the spectrum analyser while ensuring the necessary measurement accuracy, particularly close to the carrier.
- b) The frequency range 1 000 MHz to 40 GHz shall be investigated for unwanted emissions whilst in the carrier-on state with the carrier at maximum power and normally modulated. The power density of the unwanted emissions identified shall be measured.
- c) To obtain the maximum EIRP, the maximum antenna gain measured at the frequency of the identified unwanted emission shall be added to the measured power density and any correction or calibration factors summated with the result. If agreed by the manufacturer, it shall be acceptable that the maximum antenna gain measured under clause 6.3.3.2 is used in place of the maximum antenna gain at the frequency of the identified unwanted emission.
- d) The test shall be repeated in the carrier-off state.

6.2 Unwanted emissions within the band 14,00 GHz to 14,25 GHz

6.2.1 Test method

For purpose of the test, the EUT comprises:

- a) for IE:
 - the EME;
 - the IME;
 - a connection cable between IME and EME unit;
 - the necessary power supply cables and any other cable ensuring a proper functioning of the terminal.
- b) for PE:
 - for a single module PE, the module itself with any deployable parts in their normal operating configuration;
 - for a multiple module PE, all such modules with all necessary interconnecting cables of lengths as normally supplied by the manufacturer; again any deployable parts should be in their normal operating configuration.

The distance between the EUT or the substitution antenna and the measuring antenna shall be such that the radiating near-field of each antenna shall not overlap with that of the other. The larger radiating near-field of the EUT and substitution antenna shall be used to determine the minimum distance between the EUT and measuring antenna in the first instance.

6.2.1.1 General

For MES equipment for which measurements at the antenna flange are possible and agreed by the manufacturer, the measurements shall be performed at the antenna flange.

For MES equipment for which measurements at the antenna flange are not possible or not agreed by the manufacturer, the measurements shall be performed with a test antenna.

6.2.1.2 Method of measurement at the antenna flange

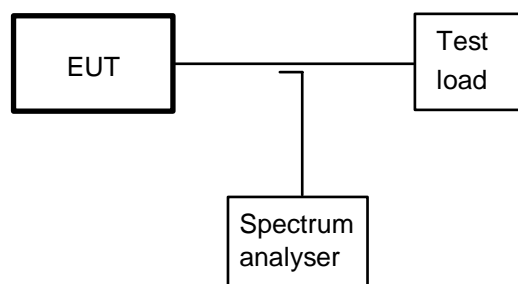

Figure 8: Test arrangement - on-axis unwanted emissions measurements at the antenna flange

- a) The EUT shall be connected to a test load as shown in figure 8.
- b) The frequency range 14,00 GHz to 14,25 GHz shall be investigated. For carrier-on state, the measurement shall not be performed within the nominated bandwidth. The measurement shall be performed whilst transmitting a modulated carrier at maximum power. The carrier frequency shall be as close as possible to the lower limit of the operating frequency band of the EUT declared by the manufacturer.
- c) The spectrum analyser resolution bandwidth shall be set to the appropriate measuring bandwidth or as close as possible. If the resolution bandwidth is different from the specified measuring bandwidth, bandwidth correction shall be performed for noise-like wideband spurious radiation.

- d) To obtain the on-axis unwanted emission power level that would be transmitted, the antenna isotropic transmit gain shall be added to any figure obtained in the above measurement and any correction or calibration factor summated with the result.
- e) The antenna gain shall be as measured in clause 6.3.3.2.
- f) The tests in b) to e) shall be repeated in the carrier-off state.
- g) The tests in b) to f) shall be repeated with a transmit frequency as close to the upper limit of the operating frequency band of the EUT as possible.

6.2.1.3 Method of measurement with a test antenna

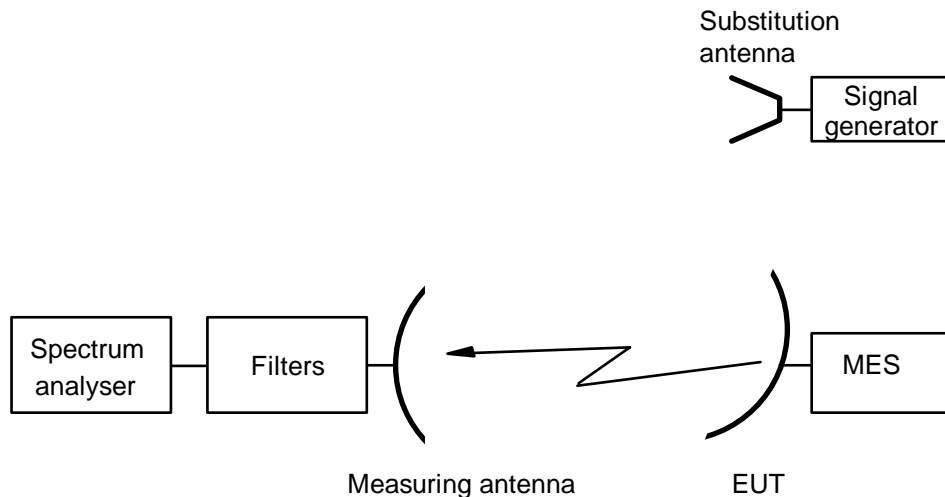

Figure 9: Test arrangement - on-axis unwanted emissions measurements with a measuring antenna

- a) The test arrangement shall be as shown in figure 9.
- b) The frequency range 14,00 GHz to 14,25 GHz shall be investigated. For carrier-on state, the measurement shall not be performed within the nominated bandwidth. The measurement shall be performed whilst transmitting a modulated carrier at maximum power. The carrier frequency shall be as close as possible to the lower limit of the operating frequency band of the EUT declared by the manufacturer.
- c) The spectrum analyser resolution bandwidth shall be set to the appropriate measuring bandwidth or as close as possible. If the resolution bandwidth is different from the specified measuring bandwidth, bandwidth correction shall be performed for noise-like wideband spurious radiation.
- d) The EUT shall be installed such that the various units are placed in their normal operating positions relative to each other. Any interconnection cables shall be maintained by non-metallic means at a height between 0,5 m and 1,0 m.
- e) The measuring antenna shall be adjusted in height and the EUT rotated for a maximum response on the associated spectrum analyser at each unwanted emission identified, this response level shall be noted.
- f) The measuring antenna shall be adjusted in height and polarization and the EUT rotated for a maximum response on the associated spectrum analyser at each unwanted emission previously identified, this response level shall be noted.
- g) The EUT shall be replaced by the substitution antenna to which is connected a signal generator. The main beam axes of the measuring and substitution antennas shall be aligned.
- h) The substitution and measuring antennas shall be aligned in the polarization which produced the larger response between the EUT and the test antenna, in steps e) and f).
- j) The output of the generator shall be adjusted so that the received level is identical to that of the previously noted largest unwanted emission.

- k) The output level of the signal generator shall be noted. The EIRP of the on-axis unwanted emission is the sum, in dB, of the signal generator output plus the substitution antenna isotropic gain minus the interconnection cable loss.
- l) The tests in d) to k) shall be repeated in the carrier-off state.

6.3 Off-axis EIRP emissions density in the nominated bandwidth

6.3.1 General

Conformance shall be determined from:

- a) the measurement of the static rms pointing accuracy;
- b) the measurement of the off-axis EIRP.

For the measurement of the off-axis EIRP, the EUT shall be either with or without its antenna:

- For MES equipment for which measurements at the antenna flange are possible and agreed by the manufacturer, the EUT shall be without the antenna. The test shall be performed in three stages:
 - a) the measurement of the transmitter output power density (dBW/40 kHz);
 - b) the measurement of the antenna transmit gain (dBi);
 - c) the measurement of the antenna transmit radiation patterns (dBi).
- For MES equipment for which measurements at the antenna flange are not possible or not agreed by the manufacturer, the EUT shall be fitted with the antenna. The test shall be performed in three stages:
 - a) the measurement of the maximum EIRP density per 40 kHz ratio relative to the EIRP (dBc/40 kHz);
 - b) the measurement of the maximum on-axis EIRP (dBW);
 - c) the measurement of the antenna transmit radiation patterns (dBi).

6.3.2 Static rms antenna pointing accuracy

6.3.2.1 Method of measurement

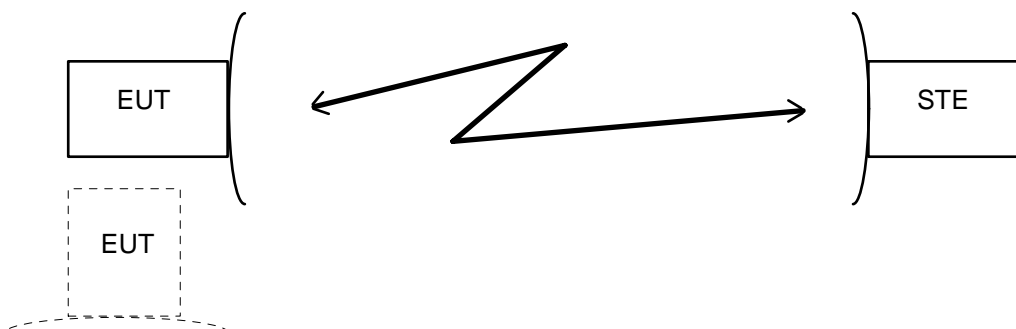

Figure 10: Test arrangement - static rms pointing accuracy

- a) The equipment shall be arranged as shown in figure 10 such that the two antennas are in the far field of each other with the EUT rotated away from the STE. The STE shall be switched-on and the EUT shall be switched-off.
- b) The level of the signal radiated by the STE shall be adjusted so that the EUT receives a power density corresponding to the signal to noise ratio declared by the manufacturer. This power density shall be representative of those expected for 95 % of the MES within the network and typically will be 2 dB above the edge of coverage figures for which the MES is designed to operate.
- c) The EUT shall be switched-on and allowed to acquire the static pointing position.
- d) The static pointing accuracy shall be measured and recorded. The method of measurement to be used shall be agreed between the manufacturer and the test house.
- e) The static pointing accuracy shall be monitored to ascertain if the pointing varies, if so the rms value of this pointing angle shall be taken.
- f) The static pointing accuracy shall be measured five times.
- g) The EUT shall be switched-off whilst the EUT is rotated through at least 90° and for a minimum period of 1 s.
- h) The tests in c) to f) shall be repeated.
- j) The value of rms static pointing accuracy shall be taken to be the largest value of the ten measurement results recorded.

6.3.3 Measurement of the off-axis EIRP without the antenna

6.3.3.1 Transmitter output power density

For purpose of the test, the EUT comprises all of the equipment noted up to the antenna flange:

- a) for IE:
 - the EME;
 - the IME;
 - a connection cable between IME and EME unit;
 - the necessary power supply cables and any other cable ensuring a proper functioning of the terminal.
- b) for PE:
 - for a single module PE, the module itself with any deployable parts in their normal operating configuration;
 - for a multiple module PE, all such modules with all necessary interconnecting cables of lengths as normally supplied by the manufacturer; again any deployable parts should be in their normal operating configuration.

Where the EUT is so designed that it is not normally possible to make a direct connection to the feed at the antenna flange, or connecting point, the manufacturer shall provide a means of so doing specifically for the test MES.

6.3.3.1.1 Method of measurement

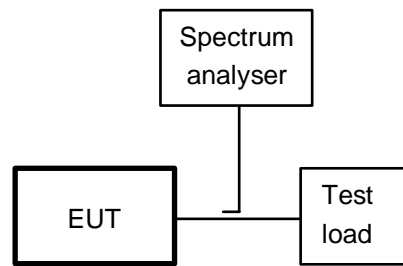

Figure 11: Test arrangement - transmit output power density measurement

- a) The EUT shall be connected to a test load as shown in figure 11.
- b) With the carrier being modulated by a pseudo random bit sequence, the maximum power density supplied to the antenna flange shall be measured in dBW/40 kHz. The coupling factor of the test coupler at the test frequency and the attenuation of any necessary waveguide adapter shall be taken into account. The resolution bandwidth of the spectrum analyser shall be set as close as possible to the specified measuring bandwidth. If the resolution bandwidth is different from the specified bandwidth then bandwidth correction shall be performed.

6.3.3.2 Antenna transmit gain

6.3.3.2.1 General

For the purpose of the present document, the antenna transmit gain is defined as the ratio, expressed in decibels, of the power that would have to be supplied to the reference antenna, i.e. an isotropic radiator isolated in space, to the power supplied to the antenna being considered, so that they produce the same field strength at the same distance in the same direction. Unless otherwise specified the gain is for the direction of maximum radiation.

For the purpose of this test the EUT is defined as that part of the MES which comprises the antenna and its flange. The EUT includes an enclosure of equal weight/distribution to any electrical equipment normally housed within the antenna (see clause 6.3.3.1 regarding this requirement).

6.3.3.2.2 Test site

This test shall be performed on either an outdoor far-field test site or compact test range. However, if the near-field scanner technology to convert near-field measurements to far-field results is proven and sufficiently accurate by reference to tests taken in both regions then antenna measurements may be taken in the near field.

6.3.3.2.3 Method of measurement

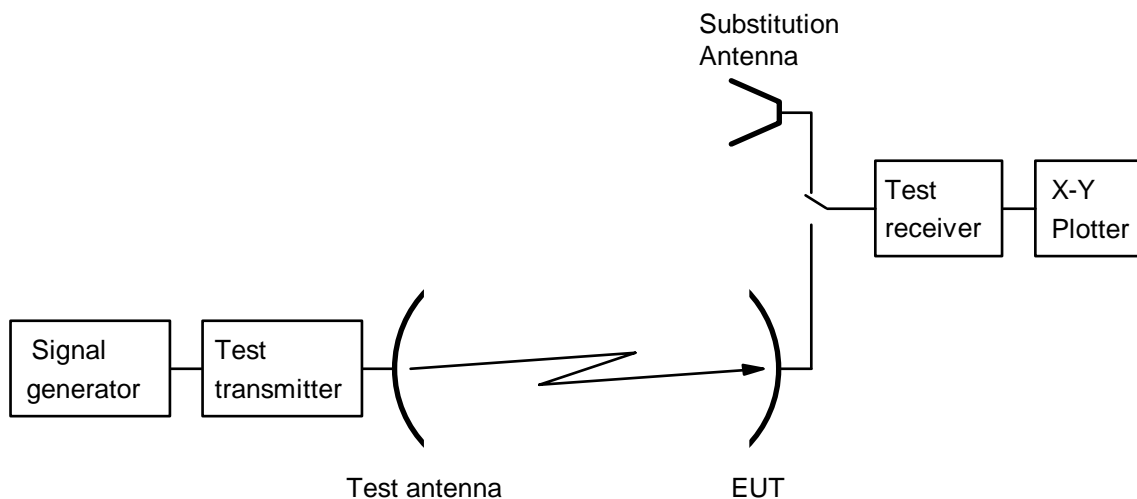

Figure 12: Test arrangement - antenna transmit gain measurement

- a) The test arrangement shall be as shown in figure 12 with the EUT connected to the test receiver. A signal proportional to the angular position from the servo mechanism shall be applied to the X-axis and the signal level from the test receiver shall be applied to the Y-axis of the plotter.
- b) The initial E-plane of the test signal radiated by the test transmitter through its antenna shall be horizontal. The EUT antenna main beam axis shall be aligned with the main beam axis of the test transmitter. The EUT antenna or its polarizer shall be rotated around its main beam axis such that its E-plane coincides with the E-plane of the test transmitter.
- c) After any change of the E-plane of the test signal, the EUT antenna shall be rotated around its main beam axis such that its E-plane coincides with the E-plane of the test transmitter.
- d) The frequency of the test signal shall be set 5 MHz above the bottom of the lowest frequency band declared by the manufacturer.
- e) The EUT shall be aligned to maximize the received signal and the X-Y plotter adjusted to give the maximum reading on the chart.
- f) The EUT shall be driven in azimuth in one direction through 10°.
- g) The pattern measurement is then obtained by driving the EUT in azimuth back through boresight to 10° the other side with the plotter recording the results.
- h) The EUT shall be replaced by the substitution antenna and the received signal level maximized.
- j) This level shall be recorded on the X-Y plotter.
- k) The substitution antenna shall be driven in azimuth as in f) and g).
- l) The gain of the EUT shall be calculated from:

$$G_{\text{EUT}} = L_1 - L_2 + C$$

where:

- G_{EUT} is the gain of the EUT (dBi);
 - L_1 is the level obtained with the EUT (dB);
 - L_2 is the level obtained with the substitution antenna (dB);
 - C is the calibrated gain of the substituted antenna at the test frequency (dBi).
- m) The tests in e) to l) shall be repeated with the frequency changed to the middle of the lowest frequency band declared by the manufacturer.
 - n) The tests in e) to l) shall be repeated with the frequency changed to 5 MHz below the top of the lowest frequency band declared by the manufacturer.
 - p) The tests in d) to n) may be performed simultaneously.
 - q) The tests in c) to p) shall be repeated with the E-plane vertical.
 - r) The tests in c) to p) shall be repeated with the E-plane +45° to the horizontal plane.
 - s) The tests in c) to p) shall be repeated with the E-plane -45° to the horizontal plane.
 - t) The tests in b) to s) shall be repeated for all frequency bands declared by the manufacturer.

6.3.3.3 Antenna transmit radiation patterns

6.3.3.3.1 General

For the purpose of the present document, the antenna transmit radiation patterns are diagrams relating field strength to direction relative to the pointing angle of the antenna at a constant large distance from the antenna.

For the purpose of this test the EUT is defined as that part of the MES which comprises the antenna and its flange. The antenna includes the parabolic reflector, feed, support struts and an enclosure of equal weight/distribution to any electrical equipment normally housed with the feed at the antenna focal point (see clause 6.3.3.1 regarding this requirement).

6.3.3.3.2 Test site

This test shall be performed on either an outdoor far-field test site or compact test range. However, if the near-field scanner technology to convert near-field measurements to far-field results is proven and sufficiently accurate by reference to tests taken in both regions then antenna measurements may be taken in the near field.

6.3.3.3.3 Method of measurement

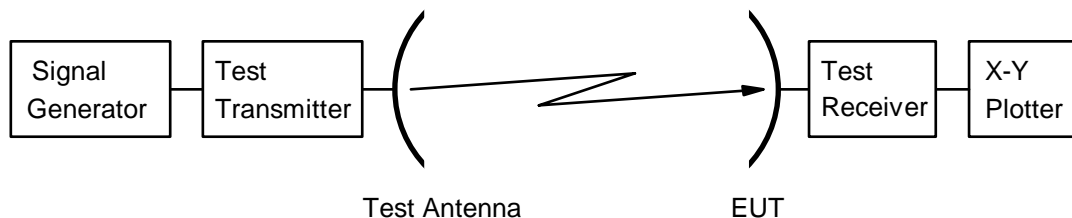

Figure 13: Test arrangement - antenna transmit radiation pattern measurement

- a) The test arrangement shall be as shown in figure 13 with the EUT connected to the test receiver. A signal proportional to the angular position from the servo mechanism shall be applied to the X-axis and the signal level from the test receiver shall be applied to the Y-axis of the plotter.
- b) The initial E-plane of the test signal radiated by the test transmitter through its antenna shall be horizontal. The EUT antenna main beam axis shall be aligned with the main beam axis of the test transmitter. The EUT antenna or its polarizer shall be rotated around its main beam axis such that its E-plane coincides with the E-plane of the test transmitter.
- c) After any change of the E-plane of the test signal, the EUT antenna shall be rotated around its main beam axis such that its E-plane coincides with the E-plane of the test transmitter.
- d) The frequency of the test signal shall be set 5 MHz above the bottom of the lowest frequency band declared by the manufacturer.
- e) The EUT shall be aligned to maximize the received signal and the X-Y plotter adjusted to give the maximum reading on the chart.
- f) The EUT shall be driven in azimuth through 180°.
- g) The transmit pattern measurement is then obtained by driving the EUT in azimuth through 360° with the plotter recording the results.
- h) The tests in c) to g) shall be repeated with the frequency changed to the middle of the lowest frequency band declared by the manufacturer.
- j) The tests in c) to g) shall be repeated with the frequency changed to 5 MHz below the top of the lowest frequency band declared by the manufacturer.
- k) The tests in c) to j) may be performed simultaneously.

- l) The tests in c) to k) shall be repeated with the E-plane being vertical.
- m) The tests in c) to k) shall be repeated with the E-plane at $+\alpha$ to the vertical plane. α° is defined as the worst case angle between the horizontal plane and the geostationary orbital arc, as seen from the range of latitudes as declared by the manufacturer.
- n) The tests in c) to k) shall be repeated with the E-plane at $-\alpha^\circ$ to the horizontal. α° is as defined in m).
- p) The tests in c) to n) shall be repeated for all frequency bands declared by the manufacturer.

6.3.3.4 Computation of results

The results shall be computed by producing a "mask" to the specified limits with the reference level being equal to the sum of the transmitter output power density, the gain of the antenna and twice the static rms pointing accuracy. This reference shall then be placed on the maximum point of the plot obtained from the transmit radiation pattern measurement, so as to ascertain that the off-axis EIRP density is within the mask, and thus conforming to the specification.

6.3.4 Measurement of the off-axis EIRP with the antenna

6.3.4.1 General

The requirements set out in clauses 6.1.1 to 6.1.3.1.2 for the measurements above 1 000 MHz shall apply.

6.3.4.2 Maximum EIRP density per 40 kHz ratio relative to the EIRP

For purpose of the test, the EUT shall be the MES fitted with its antenna.

6.3.4.2.1 Method of measurement

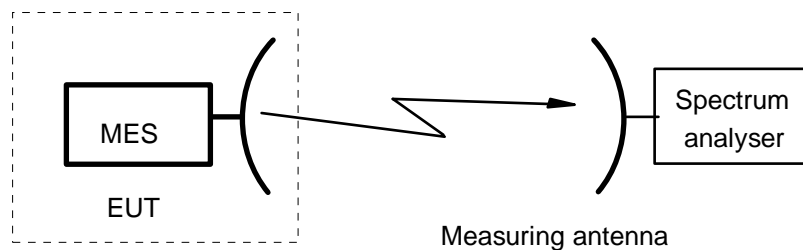

Figure 14: Test arrangement - radiated power density measurement

- a) The test arrangement shall be as shown in figure 14, both antennas being in line of sight of each other.
- b) The carrier shall be modulated by a pseudo random bit sequence. The transmission shall be continuous where possible.
- c) The resolution bandwidth of the spectrum analyser shall be set larger but as close as possible to the occupied bandwidth of the transmitted signal. The total power P1 received shall be measured in dBW.
- d) The resolution bandwidth of the spectrum analyser shall be set as close as possible to the specified measuring bandwidth: 40 kHz. If the resolution bandwidth is different from the specified bandwidth then bandwidth correction shall be performed. The maximum value P2 of the power received in any 40 kHz bandwidth over the occupied bandwidth shall be measured in dBW.
- e) The maximum EIRP density per 40 kHz ratio relative to the EIRP, in dBc/40 kHz, is the difference (P1 - P2).

6.3.4.3 Maximum on-axis EIRP

6.3.4.3.1 General

For purpose of the test, the EUT is the MES fitted with its antenna.

The distance between the EUT or the substitution antenna and the measuring antenna shall be such that the radiating near-field of each antenna shall not overlap with that of the other. The larger radiating near-field of the EUT and substitution antenna shall be used to determine the minimum distance between the EUT and measuring antenna in the first instance.

6.3.4.3.2 Test site

This test shall be performed on either an outdoor far-field test site or compact test range. However, if the near-field scanner technology to convert near-field measurements to far-field results is proven and sufficiently accurate by reference to tests taken in both regions then antenna measurements may be taken in the near field.

6.3.4.3.3 Method of measurement

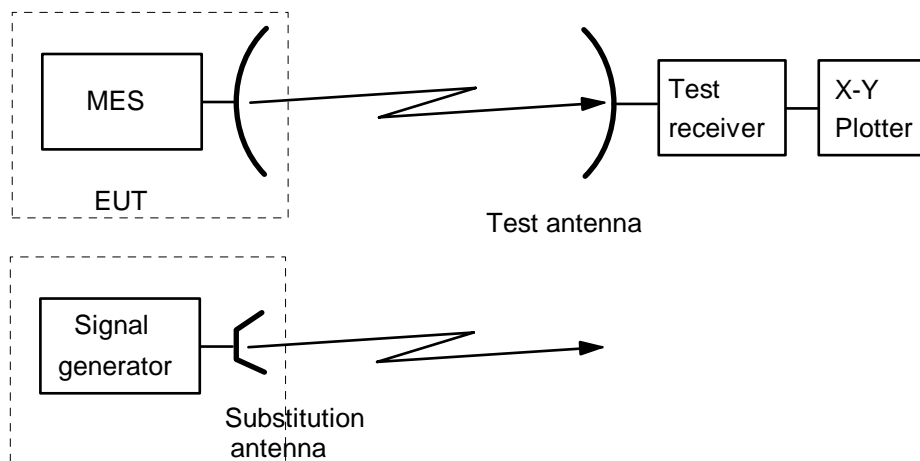

Figure 15: Test arrangement - maximum on-axis EIRP received measurement

- a) The test arrangement shall be as shown in figure 15, both antennas being in line of sight of each other. A signal proportional to the angular position from the servo mechanism shall be applied to the X-axis and the signal level from the test receiver proportional to the power received in dBW shall be applied to the Y-axis of the plotter.
- b) The carrier transmitted by the EUT shall be, at maximum power, and modulated by a pseudo random bit sequence. The transmission shall be continuous where possible.
- c) The resolution bandwidth of the spectrum analyser shall be set larger but as close as possible to the occupied bandwidth of the transmitted signal.
- d) The initial E-plane of the test signal radiated by the EUT through its antenna shall be horizontal. The test receiver antenna main beam axis shall be aligned with the main beam axis of the EUT antenna. The test receiver antenna or its polarizer shall be rotated around its main beam axis such that its E-plane coincides with the E-plane of the EUT.
- e) After any change of the E-plane of the test signal, the test receiver antenna shall be rotated around its main beam axis such that its E-plane coincides with the E-plane of the EUT.
- f) The frequency of the test signal shall be set 5 MHz above the bottom of the lowest frequency band declared by the manufacturer.
- g) The EUT shall be aligned to maximize the received signal and the X-Y plotter adjusted to give the maximum reading on the chart.
- h) The EUT shall be driven in azimuth in one direction through 10°.

- j) The pattern measurement is then obtained by driving the EUT in azimuth back through boresight to 10° the other side with the plotter recording the results.
- k) The EUT shall be replaced by the signal generator connected to a calibrated antenna (a substitution antenna), transmitting a carrier at a frequency equal to the EUT carrier frequency. The received signal level shall be maximized.
- l) This level shall be recorded on the X-Y plotter.
- m) The signal generator with the substitution antenna shall be driven in azimuth as in h) and j).
- n) The EIRP of the signal radiated by the EUT shall be calculated from:

$$\text{EIRP}_{\text{EUT}} = L_1 - L_2 + G + P$$

where:

- EIRP_{EUT} is the EIRP of the signal radiated by the EUT (dBW), in the considered direction;
 - L_1 is the level obtained with the EUT (dBW), in the considered same direction;
 - L_2 is the level obtained with the signal generator with the substitution antenna (dBW);
 - G is the calibrated gain of the substitution antenna at the test frequency (dBi);
 - P is the power produced by the signal generator at the flange of the substitution antenna (dBW).
- p) The tests in g) to n) shall be repeated with the frequency changed to the middle of the lowest frequency band declared by the manufacturer.
 - q) The tests in g) to n) shall be repeated with the frequency changed to 5 MHz below the top of the lowest frequency band declared by the manufacturer.
 - r) The tests in g) to q) may be performed simultaneously.
 - s) The tests in g) to r) shall be repeated with the E-plane vertical.
 - t) The tests in g) to r) shall be repeated with the E-plane at +45° to the horizontal plane.
 - u) The tests in g) to r) shall be repeated with the E-plane at -45° to the horizontal plane.
 - s) The tests in g) to u) shall be repeated for all frequency bands declared by the manufacturer.
 - t) The maximum on-axis EIRP of the signal radiated by the EUT is the maximum value of the values calculated in step n).

6.3.4.4 Antenna transmit radiation patterns

6.3.4.4.1 General

For the purpose of the present document, the antenna transmit radiation patterns are diagrams relating field strength to direction relative to the pointing angle of the antenna at a constant large distance from the antenna.

For purpose of the test, the EUT shall be the MES fitted with its antenna.

The distance between the EUT or the substitution antenna and the measuring antenna shall be such that the radiating near-field of each antenna shall not overlap with that of the other. The larger radiating near-field of the EUT and substitution antenna shall be used to determine the minimum distance between the EUT and measuring antenna in the first instance.

6.3.4.4.2 Test site

This test shall be performed on either an outdoor far-field test site or compact test range. However, if the near-field scanner technology to convert near-field measurements to far-field results is proven and sufficiently accurate by reference to tests taken in both regions then antenna measurements may be taken in the near field.

6.3.4.4.3 Method of measurement

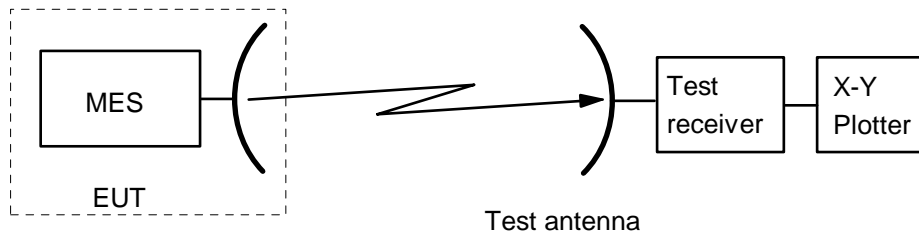

Figure 16: Test arrangement - antenna transmit radiation pattern measurement

- a) The test arrangement shall be as shown in figure 16, both antennas being in line of sight of each other. A signal proportional to the angular position from the servo mechanism shall be applied to the X-axis and the signal level from the test receiver proportional to the power received in dBW shall be applied to the Y-axis of the plotter.
- b) The carrier transmitted by the EUT shall be modulated by a pseudo random bit sequence. The transmission shall be continuous where possible.
- c) The resolution bandwidth of the spectrum analyser shall be set larger but as close as possible to the occupied bandwidth of the transmitted signal.
- d) The initial E-plane of the test signal radiated by the EUT through its antenna shall be horizontal. The test receiver antenna main beam axis shall be aligned with the main beam axis of the EUT. The test receiver antenna or its polarizer shall be rotated around its main beam axis such that its E-plane coincides with the E-plane of the EUT.
- e) After any change of the E-plane of the EUT test signal, the test receiver antenna shall be rotated around its main beam axis such that its E-plane coincides with the E-plane of the EUT.
- f) The frequency of the EUT test signal shall be set 5 MHz above the bottom of the lowest frequency band declared by the manufacturer.
- g) The EUT shall be aligned to maximize the received signal and the X-Y plotter adjusted to give the maximum reading on the chart.
- h) The EUT shall be driven in azimuth through 180°.
- j) The transmit pattern measurement is then obtained by driving the EUT in azimuth through 360° with the plotter recording the results.
- k) The tests in g) to j) shall be repeated with the frequency changed to the middle of the lowest frequency band declared by the manufacturer.
- l) The tests in g) to j) shall be repeated with the frequency changed to 5 MHz below the top of the lowest frequency band declared by the manufacturer.
- m) The tests in g) to l) may be performed simultaneously.
- n) The tests in e) to m) shall be repeated with the E-plane horizontal.
- p) The tests in e) to m) shall be repeated with the E-plane at $+\alpha^\circ$ to the horizontal plane. α° is defined as the worst case angle between the horizontal plane and the geostationary orbital arc, as seen from the range of latitudes as declared by the manufacturer.
- q) The tests in e) to m) shall be repeated with the E-plane at $-\alpha^\circ$ to the horizontal plane. α° is as defined in k).
- r) The tests in e) to q) shall be repeated for all frequency bands declared by the manufacturer.

6.3.4.5 Computation of results

The results shall be computed by producing a "mask" to the specified limits with the reference level being equal to the sum of the transmitter maximum on-axis EIRP, the maximum EIRP density per 40 kHz ratio to the EIRP, and twice the static rms pointing accuracy. This reference shall then be placed on the maximum point of the plot obtained from the transmit radiation pattern measurement, so as to ascertain that the off-axis EIRP density is within the mask, and thus conforming to the specification.

6.4 Control and monitoring

If the EUT is an MES that has been modified by the manufacturer for these tests then full documentation of such modification(s) shall be provided to prove that the modification(s) will simulate the required test condition.

For the purpose of this test the EUT is defined as the MES either with or without its antenna connected.

The measurement of the EIRP spectral density shall be limited to within either the nominated bandwidth or a 10 MHz bandwidth centred on the carrier frequency, whichever is the greater.

6.4.1 Test arrangement

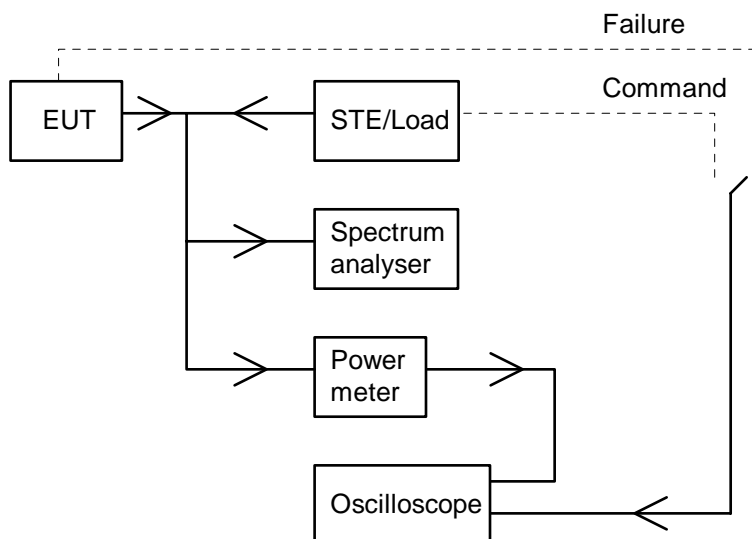

Figure 17: General test arrangement for control and monitoring tests for conducted measurements

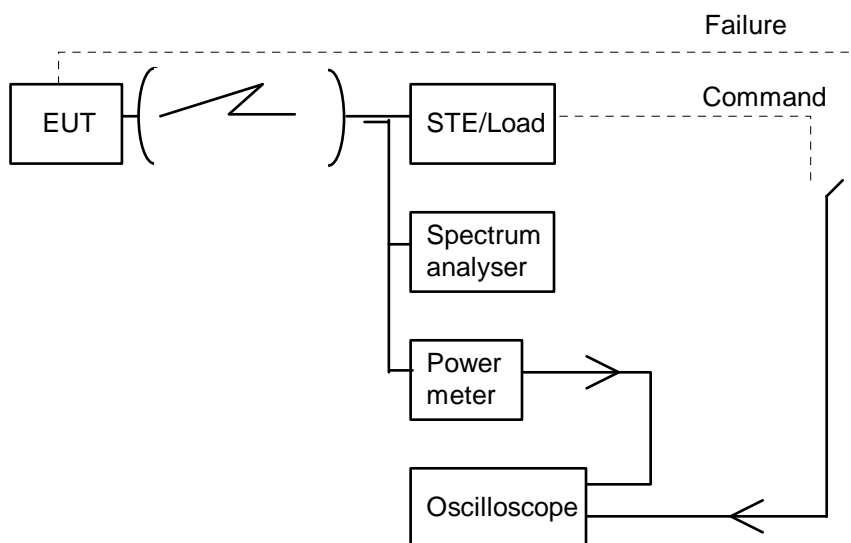

Figure 18: General test arrangement for control and monitoring tests for radiated measurements

The test arrangement shall be as shown in figure 17 or 18. The EUT shall be authorized to transmit and shall be in the carrier-on state at the commencement of each test. The dual trace storage oscilloscope shall monitor by measuring the time difference between the command, or failure, and the occurrence of the expected event (e.g. the transmission suppression). The power meter and spectrum analyser shall monitor the EUT output level.

6.4.2 Processor monitoring

6.4.2.1 Test method

- a) Each of the processors within the EUT shall, in turn, be caused to fail.
- b) Within 1 s of such failure the EUT shall cease to transmit as measured by the oscilloscope.
- c) The power meter and spectrum analyser shall be observed to ascertain that the transmissions have been suppressed.
- d) The failed processor shall be restored to normal working condition and the EUT shall be restored to normal working before the next processor shall be induced to fail.

6.4.3 Transmit subsystem monitoring

6.4.3.1 Test method

- a) The frequency generation sub-system shall be caused to fail in respect of:
 - 1) Frequency stability;
 - 2) Output.
- b) Within 6 s of such failure the EUT shall cease to transmit as measured by the oscilloscope.
- c) The power meter and spectrum analyser shall be observed to ascertain that the transmissions have been suppressed.
- d) The frequency generation sub-system shall be restored to normal working condition and the EUT shall be restored to normal working before the next induced failure.

6.4.4 Power-on/Reset

6.4.4.1 Test method

- a) The EUT shall be switched off and the STE shall not transmit the CC.
- b) The EUT shall be switched on.
- c) The EUT shall not transmit during and after switching-on, and shall enter the carrier-off state.

The events from a) to c) shall be displayed and verified with the oscilloscope and by measurement of the transmitted signal. If a manual reset function is implemented the following test shall be performed:

- d) The EUT shall be switched on and the STE shall transmit the CC.
- e) A call shall be initiated from the EUT and the EUT shall enter the carrier-on state.
- f) The reset function shall be initiated.
- g) The EUT shall enter the carrier-off state.

The event from e) to g) shall be displayed and verified with the oscilloscope and by measurement of the transmitted signal.

6.4.5 Control Channel (CC) reception

6.4.5.1 Test method

The following tests shall be performed:

- case where the CC has never been received by the EUT;
- case where the CC is lost by the EUT during a transmission period of a call;
- case where the CC is lost by the EUT during a period without transmission;
- case where the CC is being lost by the EUT and a call is initiated within the Time-Out period T1.

The Time-Out period T1 used in the tests shall be 30 seconds.

a) Case where the CC has never been received by the EUT:

- a1) The EUT shall be switched off and the STE shall not transmit the CC.
- a2) The EUT shall be switched on.
- a3) A call shall be initiated from the EUT.
- a4) The EUT shall remain in the carrier-off state.

The events from a2) to a4) shall be displayed and verified with the oscilloscope and by measurement of the transmit signal.

b) Case where the CC is lost by the EUT during a transmission period of a call:

- b1) The EUT shall be switched-on and the STE shall transmit the CC.
- b2) A call shall be initiated from the EUT.
- b3) The STE shall stop transmitting the CC.
- b4) Within T1 from b3), the EUT shall enter the carrier-off state.

The events from b2) to b4) shall be displayed and verified with the oscilloscope and by measurement of the transmitted signal.

c) Case where the CC is lost by the EUT during a period without transmission:

- c1) The EUT shall be switched on and the STE shall transmit the CC.
- c2) The STE shall stop transmitting the CC.
- c3) More than T1 later, a call shall be initiated from the EUT.
- c4) The EUT shall remain in the carrier-off state.

The events from c2) to c4) shall be displayed and verified with the oscilloscope and by measurement of the transmitted signal.

d) Case where the CC is being lost by the EUT and a call is initiated within the T1 period:

- d1) The EUT shall be switched on and the STE shall transmit the CC.
- d2) The STE shall stop transmitting the CC.
- d3) Within the period T1 from d2), a call shall be initiated from the EUT.
- d4) The EUT may transmit but within the T1 period the EUT shall enter the carrier-off state.

The events from d2) to d4) shall be displayed and verified with the oscilloscope and by measurement of the transmitted signal.

6.4.6 Network control commands

6.4.6.1 Test method

The following tests shall be performed in sequence:

- Transmission enable command.
- Transmission disable command.
- Identification request.
- a) Transmission enable command:
 - a1) The EUT shall be switched-on and the STE shall transmit the CC.
 - a2) The EUT shall enter the carrier-off state.
 - a3) A call shall be initiated from the EUT, the EUT shall remain in the carrier-off state.
 - a4) The STE shall transmit an enable command to the EUT.
 - a5) A call shall be initiated from the EUT.
 - a6) The EUT shall enter the carrier-on state and shall transmit.

The events from a2) to a6) shall be displayed and verified with the oscilloscope and by measurement of the transmitted signal.

- b) Transmission disable command:
 - b1) Continue from a6).
 - b2) The STE shall transmit a disable command to the EUT.
 - b3) The EUT shall enter the carrier-off state within 1 s.
 - b4) A call shall be initiated from the EUT.
 - b5) The EUT shall remain in the carrier-off state.
 - b6) The STE shall transmit an enable command.
 - b7) A call shall be initiated from the EUT.
 - b8) The EUT shall enter the carrier-on state and shall transmit.
 - b9) The call shall be terminated at the EUT.

The events from b2) to b9) shall be displayed and verified with the oscilloscope and by measurement of the transmitted signal.

- c) Identification request:
 - c1) Continue from b9).
 - c2) The STE shall transmit an identification request.
 - c3) The EUT shall enter the carrier-on state and shall transmit its identification code.

The STE shall display the identification code sent by the EUT.

6.4.7 Initial burst transmission

6.4.7.1 Test method

- a) The EUT shall be switched-off and the STE shall transmit the CC.
- b) The EUT shall be switched-on.
- c) The EUT shall not transmit, except the initial bursts, if any.
- d) Each initial burst shall not last more than 1 second, and the transmission of the initial bursts shall not exceed 1 % of the time.

The events from b) to d) shall be displayed and verified with the oscilloscope and by measurement of the transmitted signal.

Annex A (normative): The EN Requirements Table (EN-RT)

Notwithstanding the provisions of the copyright clause related to the text of the present document, ETSI grants that users of the present document may freely reproduce the EN-RT proforma in this annex so that it can be used for its intended purposes and may further publish the completed EN-RT.

The EN Requirements Table (EN-RT) serves a number of purposes, as follows:

- it provides a tabular summary of all the requirements;
- it shows the status of each EN-Requirement, whether it is essential to implement in all circumstances (Mandatory), or whether the requirement is dependent on the manufacturer having chosen to support a particular optional service or functionality (Optional). In particular it enables the EN-Requirements associated with a particular optional service or functionality to be grouped and identified;
- when completed in respect of a particular equipment it provides a means to undertake the static assessment of conformity with the EN.

The EN-RT is placed in an annex of the EN in order that it may be photocopied and used as a proforma.

Table A.1: EN Requirements Table (EN-RT)

EN Reference		EN TBR 301 427				Comment
No.	Reference	EN-Requirements (see note)	Status			
1	4.2.1	Unwanted emissions outside the 14,00 GHz to 14,25 GHz band	M			
2	4.2.2	Unwanted emissions within the 14,00 GHz to 14,25 GHz band	M			
3	4.2.3	Off-axis EIRP density in the Nominated bandwidth	M			
4	4.2.4.1	Processor monitoring	M			
5	4.2.4.2	Transmit subsystem monitoring	M			
6	4.2.4.3	Power-on/Reset	M			
7	4.2.4.4	Control Channel (CC) reception	M			
8	4.2.4.5	Network control commands	M			
9	4.2.4.6	Initial burst transmission	M			

NOTE: These EN-Requirements are justified under article 3.2 of the R&TTE Directive.

Key to columns:

No	Table entry number;
Reference	Clause reference number of conformance requirement within the present document;
Status	Status of the entry as follows:
M	Mandatory, shall be implemented under all circumstances;
O	Optional, may be provided, but if provided shall be implemented in accordance with the requirements;
O.n	This status is used for mutually exclusive or selectable options among a set. The integer "n" shall refer to a unique group of options within the EN-RT. A footnote to the EN-RT shall explicitly state what the requirement is for each numbered group. For example, "It is mandatory to support at least one of these options", or, "It is mandatory to support exactly one of these options".
Comments	To be completed as required.

Annex B (informative): Bibliography

- ETSI ETS 300 255 (1994): "Satellite Earth Stations and Systems (SES); Land Mobile Earth Stations (LMESs) operating in the 11/12/14 GHz bands providing Low Bit Rate Data Communications (LBRDCs)".
- ETSI ETS 300 456 (1995): "Satellite Earth Stations and Systems (SES); Test methods for Very Small Aperture Terminals (VSATs) operating in the 11/12/14 GHz frequency bands".
- EN 55022 (1994): "Limits and methods of measurement of radio disturbance characteristics of information technology equipment".
- ETSI TBR 027: "Satellite Earth Stations and Systems (SES); Low data rate Land Mobile satellite Earth Stations (LMES) operating in the 11/12/14 GHz frequency bands".
- ETSI SR 001 470: "Guidance to the production of candidate Harmonized Standards for application under the R&TTE Directive (1999/5/EC); Pro-forma candidate Harmonized Standard".

History

Document history		
V1.1.1	May 2000	Publication
V1.2.1	July 2001	One-step Approval Procedure OAP 20011102: 2001-07-04 to 2001-11-02