

# ETSI EN 301 426 V1.1.1 (2000-05)

---

*Candidate Harmonized European Standard (Telecommunications series)*

**Satellite Earth Stations and Systems (SES);  
Harmonized EN for Low data rate Land Mobile satellite  
Earth Stations (LMES) operating  
in the 1,5/1,6 GHz frequency bands  
covering essential requirements under Article 3.2  
of the R&TTE directive**

---



---

**Reference**

DEN/SES-000-TBR26

---

**Keywords**

earth station, LMES, regulation, satellite

**ETSI**

---

650 Route des Lucioles  
F-06921 Sophia Antipolis Cedex - FRANCE

Tel.: +33 4 92 94 42 00 Fax: +33 4 93 65 47 16

Siret N° 348 623 562 00017 - NAF 742 C  
Association à but non lucratif enregistrée à la  
Sous-Préfecture de Grasse (06) N° 7803/88

---

**Important notice**

Individual copies of the present document can be downloaded from:

<http://www.etsi.org>

The present document may be made available in more than one electronic version or in print. In any case of existing or perceived difference in contents between such versions, the reference version is the Portable Document Format (PDF).

In case of dispute, the reference shall be the printing on ETSI printers of the PDF version kept on a specific network drive within ETSI Secretariat.

Users of the present document should be aware that the document may be subject to revision or change of status.

Information on the current status of this and other ETSI documents is available at <http://www.etsi.org/tb/status/>

If you find errors in the present document, send your comment to:

editor@etsi.fr

---

**Copyright Notification**

No part may be reproduced except as authorized by written permission.  
The copyright and the foregoing restriction extend to reproduction in all media.

© European Telecommunications Standards Institute 2000.  
All rights reserved.

# Contents

Intellectual Property Rights .....	5
Foreword .....	5
Introduction .....	5
1 Scope .....	9
2 References .....	9
3 Definitions and abbreviations .....	10
3.1 Definitions .....	10
3.2 Abbreviations .....	10
4 Technical requirement specifications .....	11
4.1 Environmental profile.....	11
4.2 Conformance Requirements .....	11
4.2.1 Unwanted emissions outside the bands.....	11
4.2.1.1 Justification .....	11
4.2.1.2 Specification.....	11
4.2.1.3 Conformance tests .....	13
4.2.2 Maximum unwanted emission within the bands.....	13
4.2.2.1 Justification .....	13
4.2.2.2 Specification.....	13
4.2.2.3 Conformance tests .....	14
4.2.3 Control and Monitoring Functions (CMFs).....	14
4.2.3.1 General .....	14
4.2.3.2 Processor monitoring .....	14
4.2.3.2.1 Justification.....	14
4.2.3.2.2 Specification.....	14
4.2.3.2.3 Conformance tests .....	14
4.2.3.3 Transmit subsystem monitoring .....	14
4.2.3.3.1 Justification.....	14
4.2.3.3.2 Specification.....	14
4.2.3.3.3 Conformance tests .....	15
4.2.3.4 Power-on/Reset .....	15
4.2.3.4.1 Justification.....	15
4.2.3.4.2 Specification.....	15
4.2.3.4.3 Conformance tests .....	15
4.2.3.5 Control Channel reception .....	15
4.2.3.5.1 Justification.....	15
4.2.3.5.2 Specification.....	15
4.2.3.5.3 Conformance tests .....	15
4.2.3.6 Network control commands .....	15
4.2.3.6.1 Justification.....	15
4.2.3.6.2 Specification.....	15
4.2.3.6.3 Conformance test.....	16
4.2.3.7 Initial burst transmission .....	16
4.2.3.7.1 Justification.....	16
4.2.3.7.2 Specification.....	16
4.2.3.7.3 Conformance tests .....	16
5 Testing for compliance with technical requirements .....	16
5.1 Environmental conditions for testing.....	16
5.2 Essential radio test suites.....	16
5.2.1 General.....	16
5.2.2 Measurement of unwanted emissions.....	17
5.2.2.1 General .....	17

5.2.2.2	Test site .....	17
5.2.2.3	Test method.....	18
5.2.2.3.1	Installation .....	18
5.2.2.3.2	Receive test equipment .....	18
5.2.2.3.2.1	Measuring receiver for measurements up to 1 000 MHz .....	18
5.2.2.3.2.2	Spectrum analyser for measurements above 1 000 MHz .....	18
5.2.2.4	Procedure .....	19
5.2.2.4.1	Test arrangements.....	19
5.2.2.4.2	Up to 1 000 MHz.....	19
5.2.2.4.3	Above 1 000 MHz .....	20
5.2.3.	LMES Control and Monitoring Functions (CMF) .....	20
5.2.3.1	General .....	20
5.2.3.2	Test arrangement.....	21
5.2.3.3	Processor monitoring .....	21
5.2.3.3.1	Test method .....	21
5.2.3.4	Transmit subsystem monitoring .....	22
5.2.3.4.1	Test method .....	22
5.2.3.5	Power-on/Reset .....	22
5.2.3.5.1	Test method .....	22
5.2.3.6	Control channel reception .....	22
5.2.3.6.1	Test method .....	22
5.2.3.7	Network control commands .....	23
5.2.3.7.1	Test method .....	23
5.2.3.8	Initial burst transmission .....	24
5.2.3.8.1	Test method .....	24
<b>Annex A (normative):</b>	<b>The EN Requirements Table (EN-RT) .....</b>	<b>25</b>
Bibliography .....		26
History .....		27

---

## Intellectual Property Rights

IPRs essential or potentially essential to the present document may have been declared to ETSI. The information pertaining to these essential IPRs, if any, is publicly available for **ETSI members and non-members**, and can be found in SR 000 314: *"Intellectual Property Rights (IPRs); Essential, or potentially Essential, IPRs notified to ETSI in respect of ETSI standards"*, which is available from the ETSI Secretariat. Latest updates are available on the ETSI Web server (<http://www.etsi.org/ipr>).

Pursuant to the ETSI IPR Policy, no investigation, including IPR searches, has been carried out by ETSI. No guarantee can be given as to the existence of other IPRs not referenced in SR 000 314 (or the updates on the ETSI Web server) which are, or may be, or may become, essential to the present document.

---

## Foreword

This Candidate Harmonized European Standard (Telecommunications series) has been produced by ETSI Technical Committee Satellite Earth Stations and Systems (SES).

The present document has been produced by ETSI in response to a mandate from the European Commission issued under Council Directive 98/34/EC [3] (as amended) laying down a procedure for the provision of information in the field of technical standards and regulations.

The present document is intended to become a Harmonized Standard, the reference of which will be published in the Official Journal of the European Communities referencing the Directive 1999/5/EC [1] of the European Parliament and of the Council of 9 March 1999 on radio equipment and telecommunications terminal equipment and the mutual recognition of their conformity ("the R&TTE Directive").

<b>National transposition dates</b>	
Date of adoption of this EN:	28 April 2000
Date of latest announcement of this EN (doa):	31 July 2000
Date of latest publication of new National Standard or endorsement of this EN (dop/e):	31 January 2001
Date of withdrawal of any conflicting National Standard (dow):	31 January 2001

## Introduction

ETSI has designed a modular structure for the standards. Each standard is a module in the structure. The modular structure is shown in figure 1.

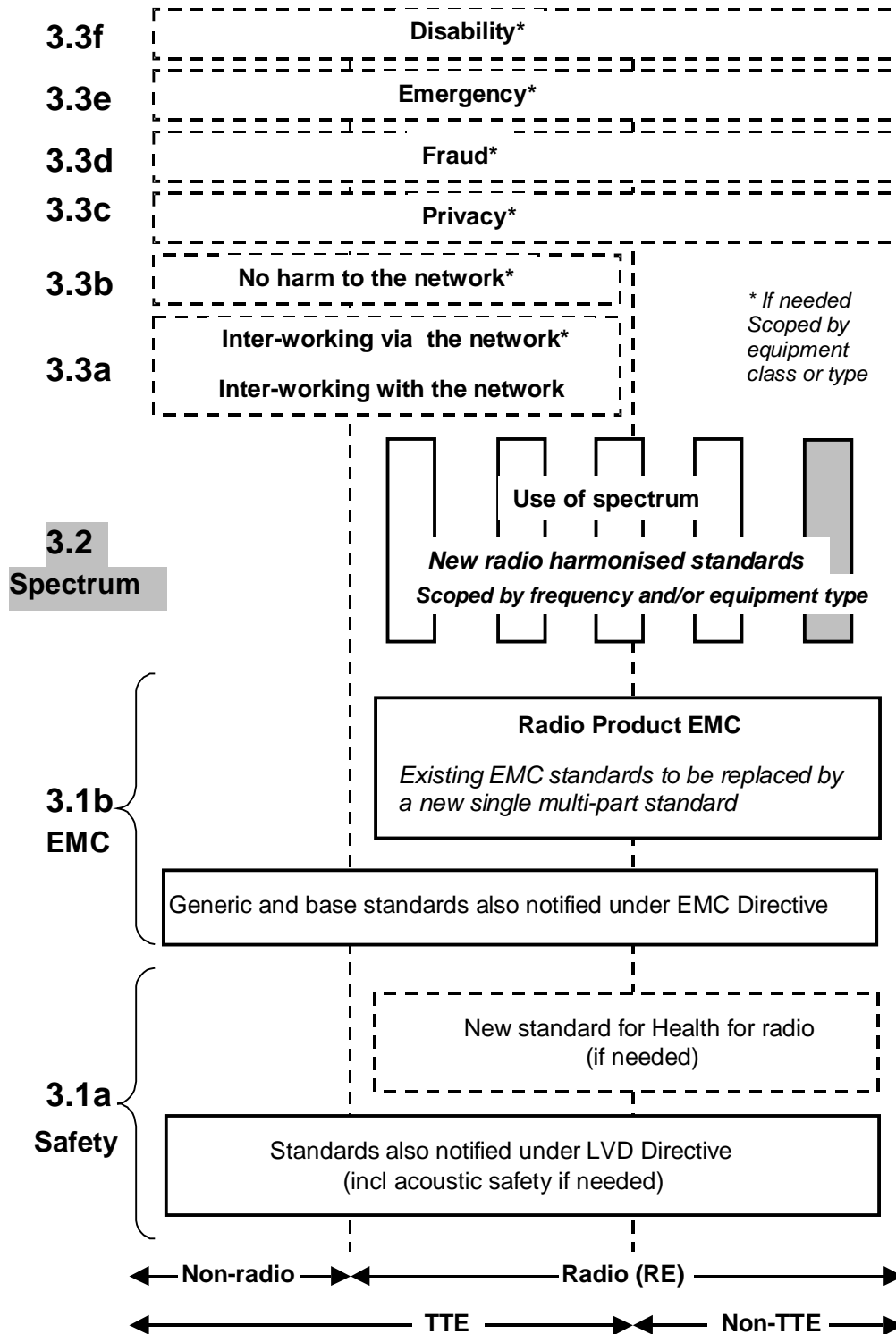

Figure 1: Modular structure for the various standards used under the R&TTE Directive

The left hand edge of the figure shows the different subclauses of Article 3 of the Directive.

For article 3.3 various horizontal boxes are shown. Their dotted lines indicate that no essential requirements in these areas have yet been adopted by the Commission. If such essential requirements are adopted, they will be elaborated in individual standards whose scope is likely to be specified by function or interface type.

The vertical boxes show the standards under article 3.2 for the use of the radio spectrum. The scopes of these standards are specified either by frequency (normally in the case where frequency bands are harmonized) or by radio equipment type.

For article 3.1(b), the diagram shows the new single multi-part product EMC standard for radio, and the existing collection of generic and base standards currently used under the EMC Directive. The parts of this new standard will become available in the second half of 2 000, and the existing separate EMC standards will be used until it is available.

For article 3.1(a) the diagram shows the existing safety standards currently used under the LVD Directive and the possibility of a new standard on health relating to radio emissions.

The bottom of the figure shows the relationship of the standards to radio equipment and telecommunications terminal equipment. A particular equipment may be radio equipment, telecommunications terminal equipment or both.

The modular approach has been taken because:

- it minimizes the number of standards needed. Because equipment may have multiple interfaces and functions it is not practicable to produce a single standard for each possible combination of functions that may occur in an equipment.
- it provides scope for standards to be added:
  - under article 3.2 when new frequency bands are agreed; or
  - under article 3.3 should the Commission take the necessary decisions.

without requiring alteration of standards that are already published.

The technical requirements in the present document are applied under Article 3.2 of the R&TTE Directive [1], concerning the effective uses of the spectrum allocated to terrestrial/space radio communication and orbital resources so as to avoid harmful interference. These requirements are in two major categories:

**emission limits:** to protect other radio services from harmful interference generated by the LMES in normal use;

**LMES Control and Monitoring Functions (CMF):** to protect other radio services from unwanted transmissions from the LMES. The CMF in each LMES is capable of answering to commands from the Network Control Facilities (NCF) for its LMES.

The requirements have been selected to ensure an adequate level of compatibility with other radio services. The levels, however, do not cover extreme cases which may occur in any location but with a low probability of occurrence.

The present document may not cover those cases where a potential source of interference which is producing individually repeated transient phenomena or a continuous phenomenon is present, e.g. a radar or broadcast site in the near vicinity. In such a case it may be necessary to use special protection applied to either the source of interference, or the interfered part or both.

The present document does not contain any requirement, recommendation or information about the installation of the LMESs.

The present document is based on TBR 26 [4], which was based on ETS 300 254 [5] which has been used for type approval purposes on a national basis for several years. For this reason, the following text was included in the TBR 26 [4] on which the present document is based, and has therefore been transposed into the present document produced under the R&TTE Directive [1] for the purpose of explaining the applicability of the tables 2a and 2b.

NOTE: Due to a new requirement for the protection of the Aeronautical Radio Navigation Service based on the Global Navigation Satellite System (GNSS), scheduled to offer approach and landing operational services likely not before the year 2005, new limits for unwanted emissions will be necessary. These new limits may not be completely met by existing or presently marketed equipment that was developed on the basis of ETS 300 254 [5] and TBR 26 [4]. Consequently the following transitional arrangement is necessary.

The present document incorporates two sets of limits. One set (table 2a) applicable up to 1 June 2002 and a more stringent set of limits (table 2b) applicable after this date for the protection of the Aeronautical Radio Navigation Service in the GNSS band.

The protection of the GNSS band from the year 2005 onwards from harmful interference from LMESs previously approved to TBR 26 [4] or complying with the present document before 1 June 2002 or already in service before the CTR 26 entered into force may be obtained either by decisions of the national regulatory authorities to stop the operation of such equipment, or by operational restrictions agreed by the regulatory authority with satellite operators. It is recommended that such decisions should be harmonized at the European level. Such decisions are outside the scope of the present document.

The determination of the parameters of the user earth stations using a given geo-stationary satellite for the protection of the spectrum allocated to that satellite, is considered to be under the responsibility of the satellite operator or the satellite network operators. Applicants for LMESs operating in satellite networks which provide radio navigation service and/or other safety services should note that such satellite network operators may require testing in addition to the present document to prove correct interworking in order to avoid the LMES causing harmful interference which endangers the functioning of these services. References to these requirements will be listed in the Bibliography of the present document as they become known.



# 1 Scope

The present document applies to Land Mobile Earth Stations (LMESs) radio equipment which have the following characteristics:

- these LMESs could be either vehicle mounted or portable equipment;
- these LMESs could consist of a number of modules including a keyboard interface to the user;
- these LMESs are operating as part of a satellite network used for the distribution and/or exchange of information between users;
- this radio equipment is capable of operating in all or any part of the frequency bands given in table 1a.

**Table 1a: Land Mobile Satellite Service frequency bands**

Direction of transmission	LMSS frequency bands
Transmit 1 (earth to space)	1 626,5 MHz to 1 645,5 MHz
Transmit 2 (earth to space)	1 656,5 MHz to 1 660,5 MHz
Receive 1 (space to earth)	1 525,0 MHz to 1 544,0 MHz
Receive 2 (space to earth)	1 555,0 MHz to 1 559,0 MHz

The present document is intended to cover the provisions of Directive 1999/5/EC [1] (R&TTE Directive) [1] Article 3.2, which states that "... radio equipment shall be so constructed that it effectively uses the spectrum allocated to terrestrial/space radio communications and orbital resources so as to avoid harmful interference".

The present document applies to the LMES with its ancillary equipment and its various terrestrial ports, and operated within the boundary limits of the operational environmental profile declared by the manufacturer.

In addition to the present document, other ENs that specify technical requirements in respect of essential requirements under other parts of Article 3 of the R&TTE Directive [1] may apply to equipment within the scope of the present document.

NOTE 1: A list of such ENs is included on the ETSI web site.

NOTE 2: These LMESs are controlled and monitored by a Network Control Facility (NCF). The NCF is outside the scope of the present document.

# 2 References

The following documents contain provisions which, through reference in this text, constitute provisions of the present document.

- References are either specific (identified by date of publication, edition number, version number, etc.) or non-specific.
- For a specific reference, subsequent revisions do not apply.
- For a non-specific reference, the latest version applies.
- A non-specific reference to an ETS shall also be taken to refer to later versions published as an EN with the same number.

[1] Directive 1999/5/EC of the European Parliament and of the Council of 9 March 1999 on radio equipment and telecommunications equipment and the mutual recognition of their conformity.

[2] CISPR 16-1: "Specification for radio disturbance and immunity measuring apparatus and methods - Part 1: Radio disturbance and immunity measuring apparatus" (annex G: Validation of the open area test site for the frequency range of 30 MHz to 1 000 MHz).

- [3] Directive 98/34/EC of the European Parliament and of the Council of 22 June 1998 laying down a procedure for the provision of information in the field of technical standards and regulations.
- [4] TBR 26: "Satellite Earth Stations and Systems (SES); Low data rate Land Mobile satellite Earth Stations (LMES) operating in the 1,5/1,6 GHz frequency bands".
- [5] ETS 300 254: "Satellite Earth Stations and Systems (SES); Land Mobile Earth Stations (LMES) operating in the 1,5/1,6 GHz bands providing Low Bit Rate Data Communications (LBRDC)".

---

## 3 Definitions and abbreviations

### 3.1 Definitions

For the purpose of the present document, the terms and definitions given in the R&TTE Directive [1], and the following terms and definitions apply.

**Environmental profile:** range of environmental conditions under which equipment within the scope of the present document is required to comply with the provisions of the present document.

**Applicant:** manufacturer or his authorized representative within the European Community or the person responsible for placing the apparatus on the market.

**carrier-off state:** LMES is in this state when either it is authorized by the Network Control Facility (NCF) to transmit but when it does not transmit any signal, or when it is not authorized by the NCF to transmit.

**carrier-on state:** LMES is in this state when it is authorized by the NCF to transmit and when it transmits a signal.

**Control Channel:** channel or channels by which LMESs receive control information from the NCF of their network.

**Externally Mounted Equipment (EME):** EME consists of those of the modules of the IE which are intended to be mounted externally to the vehicle as stated by the manufacturer.

**Installable Equipment (IE):** equipment which is intended to be fitted to a vehicle. An IE may consist of one or several interconnected modules.

**Internally Mounted Equipment (IME):** those of the modules of the IE which are not declared by the manufacturer as EME are defined as Internally Mounted Equipment (IME).

**nominated bandwidth:** bandwidth of the LMES radio frequency transmission is nominated by the manufacturer. The nominated bandwidth is wide enough to encompass all spectral elements of the transmission which have a level greater than the specified unwanted emissions limits. The nominated bandwidth is wide enough to take account of the transmit carrier frequency stability. The nominated bandwidth is within the transmit frequency band within which the LMES operates.

**Portable Equipment (PE):** portable equipment is generally intended to be self-contained, free standing and portable. A PE would normally consist of a single module, but may consist of several interconnected modules.

**unwanted emissions:** unwanted emissions are those falling outside the nominated bandwidth.

### 3.2 Abbreviations

For the purpose of the present document, the following abbreviations apply:

CC	Control Channel
CMF	Control and Monitoring Functions
EIRP	Equivalent Isotropically Radiated Power
EMC	ElectroMagnetic Compatibility
EME	Externally Mounted Equipment
ETS	European Telecommunication Standard
EUT	Equipment Under Test

IE	Installable Equipment
IME	Internally Mounted Equipment
LMES	Land Mobile Earth Station
MSS	Mobile Satellite Service
NCF	Network Control Facility
PE	Portable Equipment
R&TTE	Radio and Telecommunications Terminal Equipment
STE	Special Test Equipment
TBR	Technical Basis for Regulation

## 4 Technical requirement specifications

### 4.1 Environmental profile

The technical requirements of the present document apply under the environmental profile for operation of the equipment, which shall be declared by the applicant. The equipment shall comply with all the technical requirements of the present document at all times when operating within the boundary limits of the declared operational environmental profile.

The environmental profile for operation of the equipment shall include the ranges of humidity, temperature and supply voltage.

### 4.2 Conformance Requirements

#### 4.2.1 Unwanted emissions outside the bands

##### 4.2.1.1 Justification

Protection of terrestrial and satellite services from emissions caused by LMESs outside the bands 1 626,5 MHz to 1 645,5 MHz and 1 656,5 MHz to 1 660,5 MHz.

##### 4.2.1.2 Specification

The unwanted emissions in the measurement bandwidth and in all directions from the Land Mobile Earth Station (LMES) outside the bands 1 626,5 MHz to 1 645,5 MHz and 1 656,5 MHz to 1 660,5 MHz, within which the LMES is designed to operate, shall be below the following limits.

- 1) The unwanted emissions over the frequency range 30 MHz to 1 000 MHz shall not exceed the limits in table 1.

**Table 1: Limits of unwanted emissions up to 1 000 MHz at a measuring distance of 10 m**

Frequency (MHz)	Quasi-peak limits (dB(µV/m))
30 to 230	30
230 to 1 000	37

The lower limit shall apply at the transition frequency.

- 2) The unwanted emissions Equivalent Isotropically Radiated Power (EIRP) above 1 000 MHz, in the measurement bandwidth and in all directions shall not exceed:
  - before 1 June 2002 the limits of table 2a;
  - from 1 June 2002 the limits of table 2b.

**Table 2a: Limits of unwanted emissions above 1 000 MHz and outside the bands 1 626,5 MHz to 1 645,5 MHz and 1 656,6 MHz to 1 660,5 MHz applicable before 1 June 2002**

Frequency range (MHz)	Carrier-on		Carrier-off	
	EIRP limit (dBpW)	Measurement bandwidth (kHz)	EIRP limit (dBpW)	Measurement bandwidth (kHz)
1 000 to 1 525	49	100	48	100
1 525 to 1 559	49	100	17	3
1 559 to 1 600	49	100	48	100
1 600 to 1 626	74	100	48	100
1 626 to 1 626,5	84	3	48	100
1 645,5 to 1 645,6	104	3	57	3
1 645,6 to 1 646,1	84	3	57	3
1 646,1 to 1 655,9	74	3	57	3
1 655,9 to 1 656,4	84	3	57	3
1 656,4 to 1 656,5	104	3	57	3
1 660,5 to 1 661	84	3	48	100
1 661 to 1 690	74	100	48	100
1 690 to 3 400	49 (note 2)	100	48	100
3 400 to 10 700	55 (note 3)	100	48	100
10 700 to 21 200	61	100	54	100
21 200 to 40 000	67	100	60	100

NOTE 1: The lower limits shall apply at the transition frequencies.

NOTE 2: In the band 3 253,0 MHz to 3 321,0 MHz the maximum EIRP in one, and only one, 100 kHz measurement bandwidth shall not exceed 82 dBpW. Elsewhere in this band the power limit in this table shall be applied.

NOTE 3: In each of the bands 4 879,5 MHz to 4 981,5 MHz, 6 506,0 MHz to 6 642,0 MHz and 8 132,5 MHz to 8 302,5 MHz the maximum EIRP in one, and only one, 100 kHz measurement bandwidth shall not exceed 72 dBpW. In the band 9 759,0 MHz to 9 963,0 MHz the maximum power in one, and only one, 100 kHz measurement bandwidth shall not exceed 61 dBpW. Elsewhere in these bands the power limit in this table shall be applied.

**Table 2b: Limits of unwanted emissions above 1 000 MHz and outside the bands 1 626,5 MHz to 1 645,5 MHz and 1 656,6 MHz to 1 660,5 MHz applicable from 1 June 2002**

Frequency range (MHz)	Carrier-on		Carrier-off	
	EIRP limit (dBpW)	Measurement bandwidth (kHz)	EIRP limit (dBpW)	Measurement bandwidth (kHz)
1 000 to 1 525	49	100	48	100
1 525 to 1 559	49	100	17	3
1 559,0 to 1 580,42	50	1 000	50	1 000
1 580,42 to 1 605,0	50	1 000	50	1 000
1 605,0 to 1 610,0	(note 4)	100	(note 5)	100
1 610,0 to 1 626,0	74	100	48	100
1 626 to 1 626,5	84	3	48	100
1 645,5 to 1 645,6	104	3	57	3
1 645,6 to 1 646,1	84	3	57	3
1 646,1 to 1 655,9	74	3	57	3
1 655,9 to 1 656,4	84	3	57	3
1 656,4 to 1 656,5	104	3	57	3
1 660,5 to 1 661	84	3	48	100
1 661 to 1 690	74	100	48	100
1 690 to 3 400	49 (note 2)	100	48	100
3 400 to 10 700	55 (note 3)	100	48	100
10 700 to 21 200	61	100	54	100
21 200 to 40 000	67	100	60	100

NOTE 1: The lower limits shall apply at the transition frequencies.  
NOTE 2: In the band 3 253,0 MHz to 3 321,0 MHz the maximum EIRP in one, and only one, 100 kHz measurement bandwidth shall not exceed 82 dBpW. Elsewhere in this band the power limit in this table shall be applied.  
NOTE 3: In each of the bands 4 879,5 MHz to 4 981,5 MHz, 6 506,0 MHz to 6 642,0 MHz and 8 132,5 MHz to 8 302,5 MHz the maximum EIRP in one, and only one, 100 kHz measurement bandwidth shall not exceed 72 dBpW. In the band 9 759,0 MHz to 9 963,0 MHz the maximum power in one, and only one, 100 kHz measurement bandwidth shall not exceed 61 dBpW. Elsewhere in these bands the power limit in this table shall be applied.  
NOTE 4: Linearly interpolated from 40 dBpW in 100 kHz at 1 605,0 MHz to 74 dBpW in 100 kHz at 1 610,0 MHz.  
NOTE 5: Linearly interpolated from 40 dBpW in 100 kHz at 1 605,0 MHz to 48 dBpW in 100 kHz at 1 610,0 MHz.

#### 4.2.1.3 Conformance tests

Conformance tests shall be carried out in accordance with subclause 5.2.2.

### 4.2.2 Maximum unwanted emission within the bands

#### 4.2.2.1 Justification

Protection of satellite and terrestrial services operating in the 1 626,5 MHz to 1 645,5 MHz and 1 656,5 MHz to 1 660,5 MHz frequency bands.

#### 4.2.2.2 Specification

**Specification 1:** carrier-on state

The EIRP of the unwanted emissions in any 3 kHz bandwidth within the bands 1 626,5 MHz to 1 645,5 MHz and 1 656,5 MHz to 1 660,5 MHz shall not exceed the limits in table 3.

**Table 3: Limits of unwanted emission within the operating band with carrier-on**

Offset from the edge of the band of the nominated bandwidth (kHz)	Maximum EIRP (dBpW)
0	117
100	104
200	84
greater than 700	74

**Specification 2:** carrier-off state

The EIRP spectral density of any emission within the bands 1 626,5 MHz to 1 645,5 MHz and 1 656,5 MHz to 1 660,5 MHz shall not exceed 57 dBpW in any 3 kHz band.

**4.2.2.3 Conformance tests**

Conformance tests shall be carried out in accordance with subclause 5.2.2.

**4.2.3 Control and Monitoring Functions (CMFs)****4.2.3.1 General**

The following minimum set of CMFs shall be implemented in LMESs in order to minimize the probability that they originate unwanted transmissions that may give rise to harmful interference to other systems.

Under any fault condition when the LMES transmissions are being suppressed the limits for carrier-off state shall apply.

**4.2.3.2 Processor monitoring****4.2.3.2.1 Justification**

To ensure that the LMES can suppress transmissions in the event of a processor sub-system failure.

**4.2.3.2.2 Specification**

The LMES shall incorporate a processor monitoring function for each of its processors involved in the manipulation of traffic and in Control and Monitoring Functions (CMF).

The processor monitoring function shall detect any failure of the processor hardware and software.

No later than one second after any fault condition occurs, the LMES shall enter the carrier-off state until the processor monitoring function has determined that all fault conditions have been cleared.

**4.2.3.2.3 Conformance tests**

Conformance tests shall be carried out in accordance with subclause 5.2.3.3.

**4.2.3.3 Transmit subsystem monitoring****4.2.3.3.1 Justification**

To ensure the correct operation of the transmit frequency generation sub-system and to inhibit transmissions should the sub-system fail.

**4.2.3.3.2 Specification**

The LMES shall monitor the operation of its transmit frequency generation sub-system.

No later than 5 seconds after any fault condition of the transmit frequency generation sub-system occurs, the LMES shall enter the carrier-off state until the transmit sub-system monitoring function has determined that all fault conditions have been cleared.

#### 4.2.3.3.3 Conformance tests

Conformance tests shall be carried out in accordance with subclause 5.2.3.4.

#### 4.2.3.4 Power-on/Reset

##### 4.2.3.4.1 Justification

To demonstrate that the LMES achieves a controlled non-transmitting state following the powering of the unit, or the occurrence of a reset made by a local operator when this function is implemented.

##### 4.2.3.4.2 Specification

During and following "power on" or a manual reset when this function is implemented, the LMES shall remain in the carrier-off state.

##### 4.2.3.4.3 Conformance tests

Conformance tests shall be carried out in accordance with subclause 5.2.3.5.

#### 4.2.3.5 Control Channel reception

##### 4.2.3.5.1 Justification

To ensure that the LMES cannot transmit unless it correctly receives the Control Channel messages from the Network Control Facility (NCF).

##### 4.2.3.5.2 Specification

- a) Without correct reception of the Control Channel (CC) messages from the NCF, the LMES shall remain in the carrier-off state.
- b) The LMES shall enter the carrier-off state immediately after a period not exceeding 30 seconds without correct reception of the CC messages from the NCF. For half-duplex transmission systems in operation before 1 January 1994 this period of time shall be 15 minutes.

##### 4.2.3.5.3 Conformance tests

Conformance tests shall be carried out in accordance with subclause 5.2.3.6.

#### 4.2.3.6 Network control commands

##### 4.2.3.6.1 Justification

These requirements ensure that the LMES is capable of:

- a) retaining a unique identification in the network and transmitting it upon reception of an appropriate request;
- b) receiving commands from the NCF through its Control Channel(s) and executing those commands.

##### 4.2.3.6.2 Specification

The LMES shall hold, in non-volatile memory, its unique identification code in the network.

The LMES shall be capable of receiving through its Control Channel(s) dedicated commands (addressed to the LMES) from the NCF, and which contain:

- transmission enable commands;
- transmission disable commands;
- identification request.

Once a transmission enable command is received the LMES is authorized to transmit.

After power-on or reset the LMES shall remain in the carrier-off state until it receives a transmission enable command. For systems where no transmission enable command is expected after power-on or reset the LMES may only transmit initial bursts (see subclause 4.2.3.7).

Once a transmission disable command is received, within 1 second the LMES shall enter and shall remain in the carrier-off state until the transmission disable command is superseded by a subsequent transmission enable command.

The LMES shall be capable of transmitting its identification code upon reception of an identification request.

#### 4.2.3.6.3 Conformance test

Conformance tests shall be carried out in accordance with subclause 5.2.3.7.

#### 4.2.3.7 Initial burst transmission

##### 4.2.3.7.1 Justification

To limit disturbance to other services.

##### 4.2.3.7.2 Specification

For systems where no transmission enable command is expected after power-on or reset the LMES may transmit initial bursts:

- a) the transmission of the initial burst shall not exceed 1 % of the time;
- b) each burst shall not last more than one second.

##### 4.2.3.7.3 Conformance tests

Conformance tests shall be carried out in accordance with subclause 5.2.3.8.

---

## 5 Testing for compliance with technical requirements

### 5.1 Environmental conditions for testing

Tests defined in the present document shall be carried out at representative points within the boundary limits of the declared environmental profile.

### 5.2 Essential radio test suites

#### 5.2.1 General

The values of measurement uncertainty associated with each measurement parameter apply to all of the test cases described in the present document. The measurement uncertainties shall not exceed the values shown in table 4.



**Table 4: Measurement uncertainty**

Measurement parameter	Uncertainty
Radio frequency	±10 kHz
RF power	±0,75 dB
Conducted spurious	±4 dB
Antenna gain	±2 dB
Radiated spurious	±6 dB

To enable the performance tests to be carried out the use of Special Test Equipment (STE), made available by the manufacturer may be necessary. Since this test equipment will be specific to the particular system, it is not possible to provide detailed specifications in the present document. However, the following baseline is provided:

- if the LMES requires to receive a modulated carrier from the satellite in order to transmit, then special test arrangements are required to simulate the satellite signal, thus enabling the LMES to transmit allowing measurement of transmission parameters;
- any characteristic of these special test arrangements which may have direct or indirect effects on the parameters to be measured shall be clearly stated by the manufacturer.

All tests in the carrier-on state shall be undertaken with the transmitter operating at the maximum power setting and with the maximum transmit burst rate where applicable.

All technical characteristics and operational conditions declared by the manufacturer shall be entered in the test report.

## 5.2.2 Measurement of unwanted emissions

### 5.2.2.1 General

For purpose of the test, the Equipment Under Test (EUT) comprises:

- a) for Installable Equipment (IE):
  - the Externally Mounted Equipment (EME);
  - the Internally Mounted Equipment (IME);
  - interconnecting cables between IME and EME units as supplied by the manufacturer;
  - the necessary power supply cables and any other cable ensuring a proper functioning of the terminal.
- b) for Portable Equipment (PE):
  - for a single module PE, the module itself with any deployable parts in their normal operating configuration;
  - for a multiple module PE, all such modules with all necessary interconnecting cables of lengths as normally supplied by the manufacturer; again any deployable parts should be in their normal operating configuration.

For measurements up to 1 000 MHz the distance between the EUT and the measuring antenna shall be 10 m. For measurements above 1 000 MHz the distance between the EUT and the measuring antenna shall be such that the radiating near-field of each antenna shall not overlap with that of the other.

The highest frequency to which tests shall be performed shall be the 10th harmonic of the highest conversion frequency or ten times the highest transmit frequency, whichever is the greater. The upper and lower extremes of the tuning range shall be stated by the manufacturer.

### 5.2.2.2 Test site

The test shall be performed either in an open area test site, a semi-anechoic chamber or an anechoic chamber. Ambient noise levels shall be at least 6 dB below the applicable unwanted emissions limit.

An open area test site shall be flat, free of overhead wires and nearby reflecting structures, sufficiently large to permit aerial placement at the specified measuring distance and provide adequate separation between aerial, test unit and reflecting structures.

A metal ground plane shall be inserted on the natural ground plane and it shall extend at least 1 m beyond the perimeter of the EUT at one end and at least 1 m beyond the measurement antenna at the other end.

### 5.2.2.3 Test method

#### 5.2.2.3.1 Installation

For IE, the EUT shall be installed with a separation of about 0,5 m between the IME and the EME, the maximum length connection cable specified by the manufacturer shall be installed. The height of the cable shall be between 0,5 m and 1 m. The cable shall be maintained in that position by non-metallic means. The EME shall be set, in its normal operating configuration on a non-metallic table at a height between 0,5 m and 1 m. The IME shall be set on a non-metallic table at a height of 0,8 m for tests up to 1 000 MHz and between 0,5 m and 1 m for tests above 1 000 MHz. Any associated equipment, e.g. portable computer or data terminal if required for operation of the LMES, shall be placed next to, and at the same height as, the IME.

For PE, the equipment shall be arranged in its normal operating configuration as recommended by the manufacturer on a non-metallic table at a height between 0,5 m and 1 m.

The EUT shall be terminated with matched impedances at the terrestrial ports if recommended by the manufacturer in the user documentation and if there is no associated equipment connected to such ports.

For frequencies up to 80 MHz the measuring antenna shall be a balanced dipole which has a length equal to the 80 MHz resonant length and shall be matched to the feeder by a suitable transforming device. Measurements with broad band antennas are also possible provided that the test site has been calibrated according to the requirements of CISPR 16-1 [2].

For frequencies between 80 MHz and 1 000 MHz the measuring antenna shall be a balanced dipole which shall be resonant in length. Measurements with broad band antennas are also possible provided that the test site has been calibrated according to the requirements of CISPR 16-1 [2].

For frequencies above 1 000 MHz the antenna shall be a horn radiator of known gain/frequency characteristics. When used for reception the antenna and any associated amplification system shall have an amplitude/frequency response within  $\pm 2$  dB of the combined calibration curves across the measurement frequency range considered for the antenna. The antenna is mounted on a support capable of allowing the antenna to be used in either horizontal or vertical polarization and at the specified height.

For tests up to 1 000 MHz the receive test equipment shall be a measuring receiver. For tests above 1 000 MHz the receive test equipment shall be a spectrum analyser.

#### 5.2.2.3.2 Receive test equipment

##### 5.2.2.3.2.1 Measuring receiver for measurements up to 1 000 MHz

Measuring receivers shall conform to the following characteristics:

- the response to a constant amplitude sine wave signal shall remain within  $\pm 1$  dB across the frequency range of interest;
- quasi-peak detection shall be used in a -6 dB bandwidth of 120 kHz;
- the receiver shall be operated at more than 1 dB below the compression point during tests/measurements.

##### 5.2.2.3.2.2 Spectrum analyser for measurements above 1 000 MHz

The spectrum analyser resolution bandwidth shall be set to the specified measuring bandwidth or as close as possible. If the resolution bandwidth is different from the specified measuring bandwidth, bandwidth correction shall be performed for noise-like wideband signals. The measuring system shall be capable of detecting signals at least 6 dB below the applicable unwanted emissions limit.

## 5.2.2.4 Procedure

## 5.2.2.4.1 Test arrangements

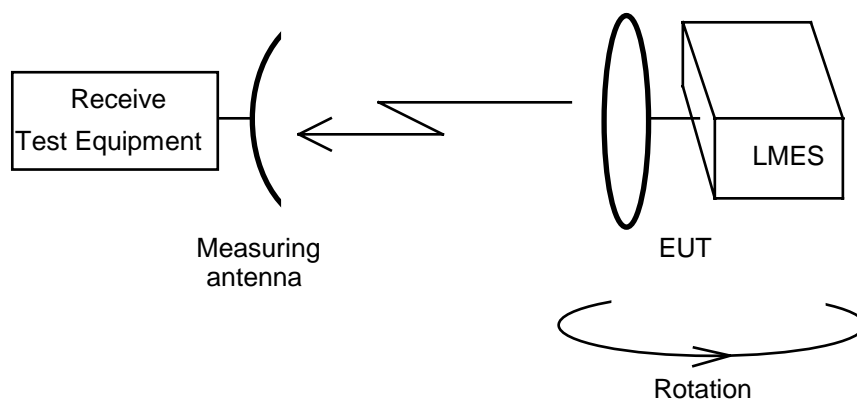

**Figure 2: Test arrangement - Unwanted emissions measurement, first axis**

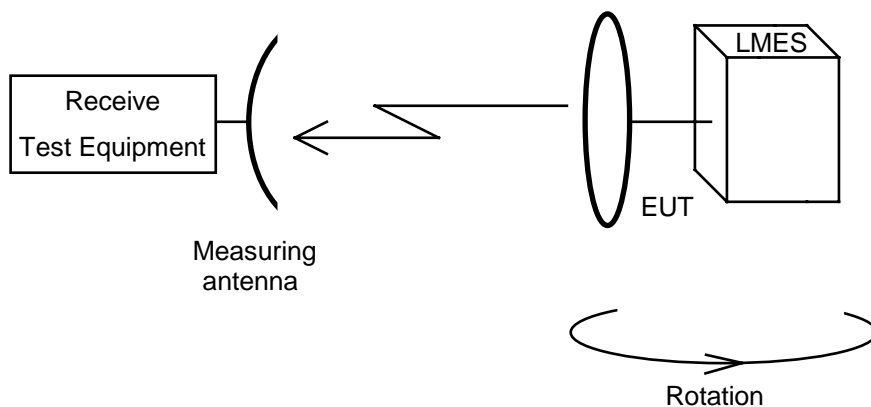

**Figure 3: Test arrangement - Unwanted emissions measurement, second axis**

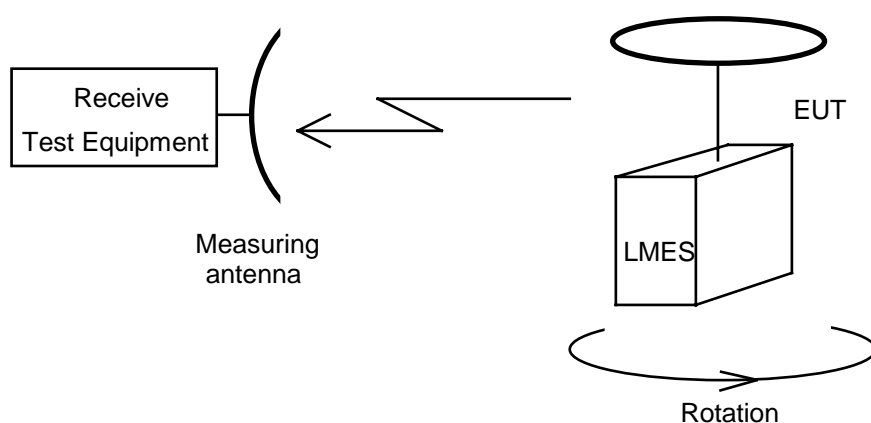

**Figure 4: Test arrangement - Unwanted emissions measurement, third axis**

## 5.2.2.4.2 Up to 1 000 MHz

- a) The test arrangement shall be as shown in figure 2 with the measuring receiver installed. EUTs with adjustable antennas shall have the antenna boresight axis in the plane of rotation. The measuring antenna boresight axis shall coincide with the plane of rotation of the boresight of the EUT.

- b) The EUT shall be in the carrier-on state with the carrier at the lowest possible centre frequency.
- c) The EUT shall be rotated through 360 degrees whilst unwanted emissions are measured in frequency and amplitude, over the frequency range 30 MHz to 1 000 MHz. The frequency and amplitude of each signal shall be noted.
- d) The measurements shall be repeated with the measuring antenna in the opposite polarization and the signal levels similarly noted.
- e) The tests in c) and d) above shall be repeated with the EUT carrier at the highest possible centre frequency.
- f) The tests in c) and d) above shall be repeated with the carrier-off.
- g) The tests in b) to f) above shall be repeated with the EUT turned so that its axis of rotation is orthogonal to that of the first case, as shown in figure 3. The EUT antenna boresight axis shall remain in the plane of rotation.
- h) The tests in b) to f) above shall be repeated with the EUT turned so that its axis of rotation is mutually orthogonal to those of the first two cases, as shown in figure 4. The EUT antenna boresight axis shall be perpendicular to the plane of rotation.

#### 5.2.2.4.3 Above 1 000 MHz

- a) The test arrangement shall be as shown in figure 2 with the spectrum analyser installed. EUTs with adjustable antennas shall have the antenna boresight axis in the plane of rotation. The measuring antenna boresight axis shall coincide with the plane of rotation of the boresight of the EUT.
- b) The EUT shall be in the carrier-on state with the carrier at the lowest possible centre frequency.
- c) The EUT shall be rotated through 360 degrees whilst unwanted emissions are measured in frequency and amplitude, over the frequency range 1 000 MHz to 40 GHz. The frequency and amplitude of each signal shall be noted.
- d) The measurements shall be repeated with the measuring antenna in the opposite polarization and the signal levels similarly noted.
- e) The tests in c) and d) above shall be repeated with the EUT carrier at the highest possible centre frequency.
- f) The tests in c) and d) above shall be repeated with the carrier-off.
- g) The tests in b) to f) above shall be repeated with the EUT turned so that its axis of rotation is orthogonal to that of the first case, as shown in figure 3. The EUT antenna boresight axis shall remain in the plane of rotation.
- h) The tests in b) to f) above shall be repeated with the EUT turned so that its axis of rotation is mutually orthogonal to those of the first two cases, as shown in figure 4. The EUT antenna boresight axis shall be perpendicular to the plane of rotation.

### 5.2.3. LMES Control and Monitoring Functions (CMF)

#### 5.2.3.1 General

If the EUT is an LMES that has been modified by the manufacturer for these tests then full documentation of such modification(s) shall be provided to prove that the modification(s) will simulate the required test condition.

For the purpose of this test the EUT is the LMES either with, or without its antenna connected.

The measurement of the EIRP spectral density shall be limited within either the nominated bandwidth or to a 10 MHz bandwidth centred on the carrier frequency whichever is the greater.

### 5.2.3.2 Test arrangement

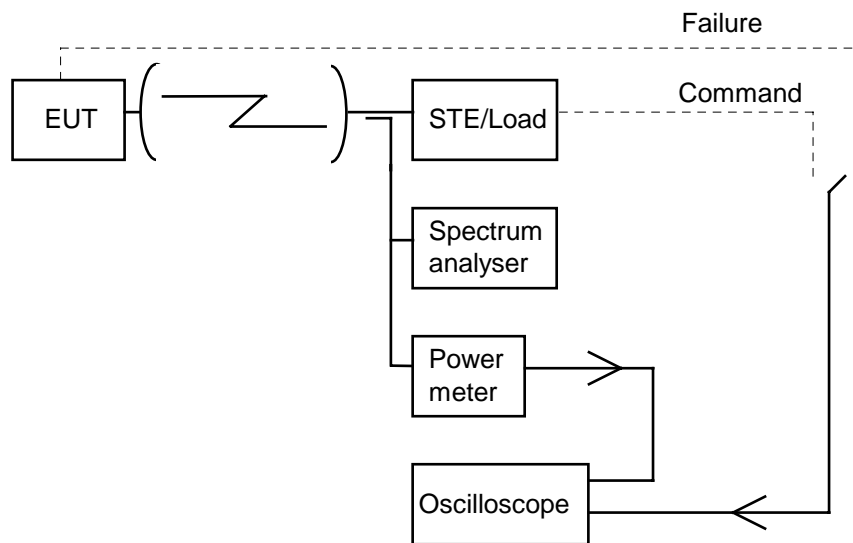

**Figure 5: General test arrangement for control and monitoring tests for radiated measurements**

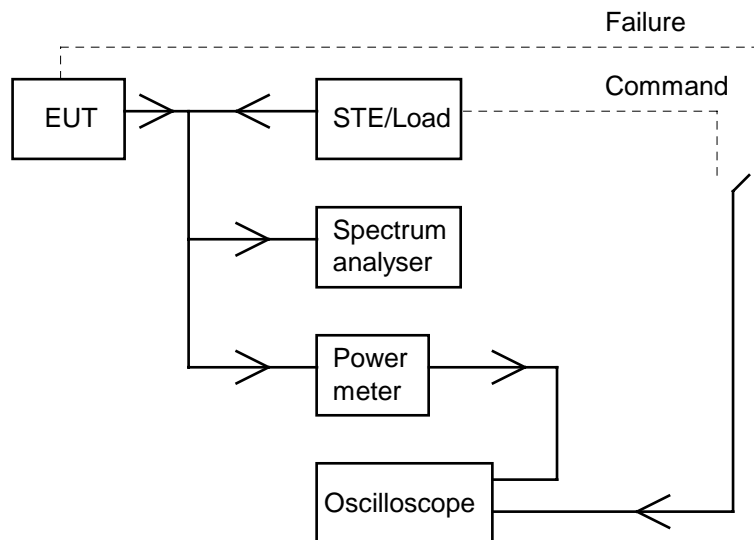

**Figure 6: General test arrangement for control and monitoring tests for conducted measurements**

The test arrangement shall be as shown in figures 5 or 6. The EUT shall be authorized to transmit and shall be in the carrier-on state at the commencement of each test, unless otherwise stated. The oscilloscope shall monitor by measuring the time difference between the command, or failure, and the occurrence of the expected event (e.g. the transmission suppression). The spectrum analyser and the power meter shall monitor the EUT output level.

### 5.2.3.3 Processor monitoring

#### 5.2.3.3.1 Test method

- Each of the processors within the EUT shall, in turn, be caused to fail.
- Within 1 second of such failure the EUT shall cease to transmit as measured by the oscilloscope.
- The power meter and spectrum analyser shall be observed to ascertain that the transmissions have been suppressed.
- The failed processor shall be restored to normal working condition and the EUT shall restore automatically to normal working before the next processor shall be induced to fail.

### 5.2.3.4 Transmit subsystem monitoring

#### 5.2.3.4.1 Test method

- a) The frequency lock subsystem within the EUT shall be caused to fail.
- b) Within 6 seconds of such failure the EUT shall cease to transmit as measured by the oscilloscope.
- c) The power meter and spectrum analyser shall be observed to ascertain that the transmissions have been suppressed.
- d) The failed elements shall be restored to normal working state and the EUT shall be restored to normal working.
- e) The frequency generation subsystem within the EUT shall be caused to fail.
- f) Within 6 seconds of such failure the EUT shall cease to transmit as measured by the oscilloscope.
- g) The power meter and spectrum analyser shall be observed to ascertain that the transmissions have been suppressed.
- h) The failed elements shall be restored to normal working state and the EUT shall be restored to normal working.

### 5.2.3.5 Power-on/Reset

#### 5.2.3.5.1 Test method

- a) The EUT shall be switched off and the STE shall not transmit the CC.
- b) The EUT shall be switched on.
- c) The EUT shall not transmit during and after switching-on, and shall enter the carrier-off state.

The events from a) to c) shall be displayed and verified with the oscilloscope and by measurement of the transmitted signal. If a manual reset function is implemented the following test shall be performed:

- d) the EUT shall be switched on and the STE shall transmit the CC;
- e) a call shall be initiated from the EUT and the EUT shall enter the carrier-on state;
- f) the reset function shall be initiated;
- g) the EUT shall enter the carrier-off state.

The event from e) to g) shall be displayed and verified with the oscilloscope and by measurement of the transmitted signal.

### 5.2.3.6 Control channel reception

#### 5.2.3.6.1 Test method

The following tests shall be performed:

- case a) where the CC has never been received by the EUT;
- case b) where the CC is lost by the EUT during a transmission period of a call;
- case c) where the CC is lost by the EUT during a period without transmission;
- case d) where the CC is being lost by the EUT and a call is initiated within the Time-Out period T1.

The Time-Out period T1 used in the tests shall be 30 seconds. For half-duplex transmission systems in operation before 1 January 1994 this Time Out T1 shall be 15 minutes.

- a) Case where the CC has never been received by the EUT:
- a1) the EUT shall be switched off and the STE shall not transmit the CC;
  - a2) the EUT shall be switched on;
  - a3) a call shall be initiated from the EUT;
  - a4) the EUT shall remain in the carrier-off state.

The events from a2) to a4) shall be displayed and verified with the oscilloscope and by measurement of the transmit signal.

- b) Case where the CC is lost by the EUT during a transmission period of a call:
- b1) the EUT shall be switched-on and the STE shall transmit the CC;
  - b2) a call shall be initiated from the EUT;
  - b3) the STE shall stop transmitting the CC;
  - b4) within T1 from b3), the EUT shall enter the carrier-off state.

The events from b2) to b4) shall be displayed and verified with the oscilloscope and by measurement of the transmitted signal.

- c) Case where the CC is lost by the EUT during a period without transmission:
- c1) the EUT shall be switched on and the STE shall transmit the CC;
  - c2) the STE shall stop transmitting the CC;
  - c3) more than T1 later, a call shall be initiated from the EUT;
  - c4) the EUT shall remain in the carrier-off state.

The events from c2) to c4) shall be displayed and verified with the oscilloscope and by measurement of the transmitted signal.

- d) Case where the CC is being lost by the EUT and a call is initiated within the T1 period:
- d1) the EUT shall be switched on and the STE shall transmit the CC;
  - d2) the STE shall stop transmitting the CC;
  - d3) within the period T1 from d2), a call shall be initiated from the EUT;
  - d4) the EUT may transmit but within the T1 period the EUT shall enter the carrier-off state.

The events from d2) to d4) shall be displayed and verified with the oscilloscope and by measurement of the transmitted signal.

### 5.2.3.7 Network control commands

#### 5.2.3.7.1 Test method

The following tests shall be performed in sequence:

- transmission enable command;
- transmission disable command;
- identification request.

## a) Transmission enable command:

- a1) the EUT shall be switched-on and the STE shall transmit the CC;
- a2) the EUT shall enter the carrier-off state;
- a3) a call shall be initiated from the EUT, the EUT shall remain in the carrier-off state;
- a4) the STE shall transmit an enable command to the EUT;
- a5) a call shall be initiated from the EUT;
- a6) the EUT shall enter the carrier-on state and shall transmit.

The events from a2) to a6) shall be displayed and verified with the oscilloscope and by measurement of the transmitted signal.

## b) Transmission disable command:

- b1) continue from a6). In the case of half-duplex systems the call shall be terminated;
- b2) the STE shall transmit a disable command to the EUT;
- b3) the EUT shall enter the carrier-off state within 1 second;
- b4) a call shall be initiated from the EUT;
- b5) the EUT shall remain in the carrier-off state;
- b6) the STE shall transmit an enable command;
- b7) a call shall be initiated from the EUT;
- b8) the EUT shall enter the carrier-on state and shall transmit;
- b9) the call shall be terminated at the EUT.

The events from b2) to b9) shall be displayed and verified with the oscilloscope and by measurement of the transmitted signal.

## c) Identification request:

- c1) continue from b9);
- c2) the STE shall transmit an identification request;
- c3) the EUT shall enter the carrier-on state and shall transmit its identification code.

The STE shall display the identification code sent by the EUT.

## 5.2.3.8 Initial burst transmission

### 5.2.3.8.1 Test method

- a) The EUT shall be switched-off and the STE shall transmit the CC.
- b) The EUT shall be switched-on.
- c) The EUT shall not transmit, except the initial bursts, if any.
- d) Each initial burst shall not last more than 1 second, and the transmission of the initial bursts shall not exceed 1% of the time.

The events from b) to d) shall be displayed and verified with the oscilloscope and by measurement of the transmitted signal.



## Annex A (normative): The EN Requirements Table (EN-RT)

Notwithstanding the provisions of the copyright clause related to the text of the present document, ETSI grants that users of the present document may freely reproduce the EN-RT proforma in this annex so that it can be used for its intended purposes and may further publish the completed EN-RT.

The EN Requirements Table (EN-RT) serves a number of purposes, as follows:

- it provides a tabular summary of all the requirements;
- it shows the status of each EN-Requirement, whether it is essential to implement in all circumstances (Mandatory), or whether the requirement is dependent on the manufacturer having chosen to support a particular optional service or functionality (Optional). In particular it enables the EN-Requirements associated with a particular optional service or functionality to be grouped and identified;
- when completed in respect of a particular equipment it provides a means to undertake the static assessment of conformity with the EN.

The EN-RT is placed in an annex of the EN in order that it may be photocopied and used as a proforma.

**Table A.1: EN Requirements Table (EN-RT)**

EN Reference		EN 301 426				Comment
No.	Reference	EN-Requirement (note)	Status			
1	4.2.1	Unwanted emissions outside the 1 626,5 MHz to 1 645,5 MHz and 1 656,5 MHz to 1 660,5 MHz bands	M			
2	4.2.2	Maximum unwanted emission within the 1 626,5 MHz to 1 645,5 MHz and 1 656,5 MHz to 1 660,5 MHz bands	M			
3	4.2.3.2	Processor monitoring	M			
4	4.2.3.3	Transmit subsystem monitoring	M			
5	4.2.3.4	Power-on/Reset	M			
6	4.2.3.5	Control Channel reception	M			
7	4.2.3.6	Network Control commands	M			
8	4.2.3.7	Initial burst transmission	M			

NOTE: These EN-Requirements are justified under Article 3.2 of the R&TTE Directive.

### Key to columns:

- No**                    Table entry number;
- Reference**           Subclause reference number of conformance requirement within the present document;
- Status**                Status of the entry as follows:
- M            Mandatory, shall be implemented under all circumstances;
- O            Optional, may be provided, but if provided shall be implemented in accordance with the requirements;
- Comments**           To be completed as required.

---

## Bibliography

The following material, though not specifically referenced in the body of the present document (or not publicly available), gives supporting information.

- EN 55022: "Limits and methods of measurement of radio disturbance characteristics of information technology equipment".
- ETS 300 282: "Satellite Earth Stations and Systems (SES); Network Control Facility (NCF) for Land Mobile satellite Earth Stations (LMES) operating in the 1,5/1,6 GHz bands and 11/12/14 GHz bands providing Low Bit Rate Data Communications (LBRDC)".
- ETS 300 831: "Electromagnetic compatibility and Radio spectrum Matters (ERM); Electromagnetic Compatibility (EMC) for Mobile Earth Stations (MES) used within Satellite Personal Communications Networks (S-PCN) operating in the 1,5/1,6/2,4 GHz and 2 GHz frequency bands".

---

## History

<b>Document history</b>		
V1.1.1	December 1999	One-step Approval Procedure OAP 200017: 1999-12-29 to 2000-04-28
V1.1.1	May 2000	Publication