

Draft **ETSI EN 301 406-1** V2.3.0 (2022-07)



**Digital Enhanced Cordless Telecommunications (DECT);
Harmonised Standard for access to radio spectrum;
Part 1: DECT, DECT Evolution and DECT ULE**

Reference

REN/DECT-00359-1

Keywords

DECT, digital, generic, radio, regulation, testing

ETSI

650 Route des Lucioles
F-06921 Sophia Antipolis Cedex - FRANCE

Tel.: +33 4 92 94 42 00 Fax: +33 4 93 65 47 16

Siret N° 348 623 562 00017 - APE 7112B
Association à but non lucratif enregistrée à la
Sous-Préfecture de Grasse (06) N° w061004871

Important notice

The present document can be downloaded from:

<http://www.etsi.org/standards-search>

The present document may be made available in electronic versions and/or in print. The content of any electronic and/or print versions of the present document shall not be modified without the prior written authorization of ETSI. In case of any existing or perceived difference in contents between such versions and/or in print, the prevailing version of an ETSI deliverable is the one made publicly available in PDF format at www.etsi.org/deliver.

Users of the present document should be aware that the document may be subject to revision or change of status.

Information on the current status of this and other ETSI documents is available at

<https://portal.etsi.org/TB/ETSIDeliverableStatus.aspx>

If you find errors in the present document, please send your comment to one of the following services:

<https://portal.etsi.org/People/CommitteeSupportStaff.aspx>

If you find a security vulnerability in the present document, please report it through our
Coordinated Vulnerability Disclosure Program:

<https://www.etsi.org/standards/coordinated-vulnerability-disclosure>

Notice of disclaimer & limitation of liability

The information provided in the present deliverable is directed solely to professionals who have the appropriate degree of experience to understand and interpret its content in accordance with generally accepted engineering or other professional standard and applicable regulations.

No recommendation as to products and services or vendors is made or should be implied.

In no event shall ETSI be held liable for loss of profits or any other incidental or consequential damages.

Any software contained in this deliverable is provided "AS IS" with no warranties, express or implied, including but not limited to, the warranties of merchantability, fitness for a particular purpose and non-infringement of intellectual property rights and ETSI shall not be held liable in any event for any damages whatsoever (including, without limitation, damages for loss of profits, business interruption, loss of information, or any other pecuniary loss) arising out of or related to the use of or inability to use the software.

Copyright Notification

No part may be reproduced or utilized in any form or by any means, electronic or mechanical, including photocopying and microfilm except as authorized by written permission of ETSI.

The content of the PDF version shall not be modified without the written authorization of ETSI.

The copyright and the foregoing restriction extend to reproduction in all media.

© ETSI 2022.
All rights reserved.

Contents

Intellectual Property Rights	10
Foreword.....	10
Modal verbs terminology.....	11
1 Scope	12
2 References	12
2.1 Normative references	12
2.2 Informative references.....	13
3 Definition of terms, symbols and abbreviations.....	14
3.1 Terms.....	14
3.2 Symbols.....	17
3.3 Abbreviations	17
4 Technical requirements specifications	18
4.1 Environmental profile.....	18
4.2 Overview	18
4.2.0 General.....	18
4.2.1 Test suites	18
4.2.2 Test groups.....	18
4.2.3 Test cases.....	19
4.3 Product information for testing	19
4.3.1 Information on capabilities and options implemented	19
4.3.2 Additional information on implementation for testing	20
4.4 Applicability of tests	20
4.4.0 Introduction.....	20
4.4.1 Equipment that includes only a DECT RF receiver.....	20
4.4.2 Equipment that includes a radio transmitter	20
4.4.3 CTAs.....	20
4.4.4 Equipment with combined FT and PT functionality.....	20
4.4.4.0 General	20
4.4.4.1 Wireless Relay Station	21
4.4.4.2 Direct PP to PP communication	21
4.4.4.3 Distributed Communications.....	21
4.4.5 Equipment that is capable of using higher level modulation	21
4.4.6 Equipment supporting additional carriers	21
4.5 Conformance requirements	21
4.5.1 Accuracy and stability of RF carriers	21
4.5.1.1 Definition	21
4.5.1.2 Limits	22
4.5.1.3 Conformance.....	22
4.5.2 Accuracy and stability of timing parameters	22
4.5.2.0 General	22
4.5.2.1 Definitions.....	22
4.5.2.1.1 Slot structure.....	22
4.5.2.1.2 Definition of the position of p0	23
4.5.2.2 Limits	23
4.5.2.2.1 Reference timer accuracy and stability.....	23
4.5.2.2.2 RFP transmission jitter	23
4.5.2.2.3 PP reference timer synchronization	23
4.5.2.3 Conformance.....	24
4.5.3 Transmission burst.....	24
4.5.3.1 Definitions.....	24
4.5.3.1.0 Introduction	24
4.5.3.1.1 Physical packets.....	24
4.5.3.1.2 Transmitted power.....	24

4.5.3.1.3	Normal Transmitted Power (NTP)	24
4.5.3.1.4	Transmitter attack time	24
4.5.3.1.5	Transmitter release time	25
4.5.3.1.6	Minimum power	25
4.5.3.1.7	Maximum power	25
4.5.3.1.8	Maintenance of transmission after packet end.....	25
4.5.3.1.9	Transmitter idle power output	25
4.5.3.2	Limits	25
4.5.3.2.1	Transmitter attack time.....	25
4.5.3.2.2	Transmitter release time	25
4.5.3.2.3	Minimum power	25
4.5.3.2.4	Maximum power	25
4.5.3.2.5	Maintenance of transmission after packet end.....	25
4.5.3.2.6	Transmitter idle power output	26
4.5.3.3	Conformance.....	26
4.5.4	Transmitted power	26
4.5.4.1	Definitions.....	26
4.5.4.1.0	Transceiver and P_{NTP} definitions.....	26
4.5.4.1.1	PP and RFP with an integral antenna	26
4.5.4.1.2	PP and RFP with external connections for all antennas	26
4.5.4.1.3	PP and RFP with both integral and external antennas	26
4.5.4.2	Limits	27
4.5.4.3	Conformance.....	27
4.5.4.4	Multi-transceiver systems	27
4.5.5	RF carrier modulation.....	27
4.5.5.1	Definition	27
4.5.5.2	Limits	27
4.5.5.3	Conformance.....	28
4.5.6	Unwanted RF power radiation	28
4.5.6.1	General	28
4.5.6.2	Emissions due to modulation	28
4.5.6.2.1	Definition.....	28
4.5.6.2.2	Limits	28
4.5.6.2.3	Conformance	28
4.5.6.3	Emissions due to transmitter transients	28
4.5.6.3.1	Definition.....	28
4.5.6.3.2	Limits	28
4.5.6.3.3	Conformance	29
4.5.6.4	Emissions due to intermodulation	29
4.5.6.4.1	Definition.....	29
4.5.6.4.2	Limits	29
4.5.6.4.3	Conformance	29
4.5.6.5	Spurious emissions when allocated a transmit channel.....	29
4.5.6.5.1	Definition.....	29
4.5.6.5.2	Limits	29
4.5.6.5.3	Conformance	30
4.5.7	Radio receiver testing	30
4.5.7.0	General	30
4.5.7.1	Radio receiver sensitivity	30
4.5.7.1.1	Definition.....	30
4.5.7.1.2	Limits	30
4.5.7.1.3	Conformance	30
4.5.7.2	Radio receiver reference BER and FER.....	30
4.5.7.2.1	Definition.....	30
4.5.7.2.2	Limits	31
4.5.7.2.3	Conformance	31
4.5.7.3	Radio receiver interference performance	31
4.5.7.3.1	Definition.....	31
4.5.7.3.2	Limits	31
4.5.7.3.3	Conformance	31

4.5.7.4	Radio receiver blocking case 1: owing to signals occurring at the same time but on other frequencies	31
4.5.7.4.1	Definition.....	31
4.5.7.4.2	Limits	31
4.5.7.4.3	Conformance	32
4.5.7.5	Radio receiver blocking case 2: owing to signals occurring at a different time.....	32
4.5.7.5.1	Definition.....	32
4.5.7.5.2	Limits	32
4.5.7.5.3	Conformance	32
4.5.7.6	Receiver intermodulation performance.....	32
4.5.7.6.1	Definition.....	32
4.5.7.6.2	Limits	32
4.5.7.6.3	Conformance	32
4.5.7.7	Spurious emissions when the PP has no allocated transmit channel.....	32
4.5.7.7.1	Definition.....	32
4.5.7.7.2	Limits	33
4.5.7.7.3	Conformance	33
4.5.8	Channel access.....	33
4.5.8.1	Channel selection.....	33
4.5.8.2	Channel confirmation.....	33
4.5.8.2.1	For the PT.....	33
4.5.8.2.2	For the FT.....	33
4.5.8.3	Channel release	34
4.5.8.4	General.....	34
4.5.8.5	Channel selection and confirmation for DECT ULE	34
4.5.8.5.1	General	34
4.5.8.5.2	For the PT.....	34
4.5.8.5.3	For the FT.....	35
4.5.9	WRS testing.....	35
4.5.9.0	General requirements	35
4.5.9.1	Testing as a PP.....	35
4.5.9.2	Testing as an RFP	35
4.5.9.3	Additional requirements.....	36
4.5.9.4	Conformance.....	39
4.5.10	Requirements for PPs with direct PP to PP communication mode.....	39
4.5.10.1	General requirements	39
4.5.10.2	Conformance.....	39
4.5.11	Direct Communication.....	39
4.5.11.0	General requirements	39
4.5.11.1	Testing as a PP.....	40
4.5.11.2	Testing as an RFP	40
4.5.11.3	Conformance.....	40
4.5.12	Higher level modulation options.....	40
4.5.12.0	Requirements	40
4.5.12.1	Conformance.....	41
5	Testing for compliance with technical requirements.....	41
5.1	General test requirements	41
5.1.1	Test philosophy.....	41
5.1.2	Test site.....	43
5.1.2.1	Open air test site.....	43
5.1.2.1.1	Description	43
5.1.2.1.2	Calibration.....	43
5.1.2.2	Anechoic chamber.....	44
5.1.2.2.1	General	44
5.1.2.2.2	Description	44
5.1.2.2.3	Influence of parasitic reflections	47
5.1.2.2.4	Calibration and mode of use.....	47
5.1.2.3	Stripline coupler.....	47
5.1.2.3.0	General	47
5.1.2.3.1	Description	47
5.1.2.3.2	Calibration	47

5.1.2.3.3	Mode of use	47
5.1.3	Standard position	48
5.1.4	Test antenna of the LT	48
5.1.5	Substitution antenna	48
5.1.6	Test fixture	48
5.1.6.1	Description	48
5.1.6.2	Calibration of the test fixture for the measurement of transmitter characteristics	49
5.1.6.3	Calibration of the test fixture for the measurement of receiver characteristics	49
5.1.6.4	Mode of use	50
5.1.7	Equipment with a temporary or internal permanent antenna connector	50
5.1.7.1	General	50
5.1.7.2	Equipment with a temporary antenna connector	50
5.1.8	Indoor test site	51
5.1.8.0	General	51
5.1.8.1	Description	51
5.1.8.2	Test for parasitic reflections	51
5.1.8.3	Calibration and mode of use	52
5.1.9	Lower Tester (LT)	52
5.1.9.1	Description	52
5.1.9.2	Connections between the EUT and the LT	53
5.1.9.3	Functions and abilities	53
5.1.9.4	Signal generation uncertainty	54
5.1.9.5	Modulated DECT-like carrier	54
5.1.9.6	CW interferers	54
5.1.9.7	DECT RF signal	54
5.1.9.8	Test modulation signals	54
5.1.10	Upper Tester (UT)	54
5.1.10.1	Description of the UT	54
5.1.10.2	The Test Standby Mode (TSM)	55
5.1.10.3	Test messages	55
5.1.10.4	Dummy setting when EUT is an RFP and is in Test Standby Mode (TSM)	55
5.1.11	Description of the lower tester FT and PT	56
5.1.12	General test methods	56
5.1.12.1	General	56
5.1.12.2	Sampling the RF signal	56
5.1.12.2.1	Introduction	56
5.1.12.2.2	Sampling method	56
5.1.12.3	Determining the reference position	56
5.1.12.3.0	General	56
5.1.12.3.1	Case 1: EUTs that cannot transmit	56
5.1.12.3.2	Case 2: EUTs that can transmit	56
5.1.12.4	Bit Error Ratio (BER) and Frame Error Ratio (FER) measurements	57
5.1.13	Test setup	57
5.1.13.1	General	57
5.1.13.2	Test setup 1	57
5.1.13.3	Test setup 2	57
5.1.13.4	Test setup 3	58
5.1.13.5	Test setup 4	58
5.1.14	Test arrangements for intermodulation measurements	59
5.1.14.1	PT to PT arrangement	59
5.1.14.2	FT to FT arrangement	59
5.1.14.3	FT to PT arrangement	60
5.1.15	Test conditions, power supply and ambient temperatures	60
5.1.15.1	General	60
5.1.15.2	Nominal test conditions	60
5.1.15.3	Extreme test conditions	61
5.1.15.4	Test power source - general requirements	62
5.1.15.5	Nominal test power source	62
5.1.15.5.1	Mains voltage	62
5.1.15.5.2	Regulated lead acid battery power sources	62
5.1.15.5.3	Nickel cadmium or nickel metal hydride battery	62
5.1.15.5.4	Other power sources	62

5.1.15.6	Extreme test power source	62
5.1.15.6.1	Mains voltage	62
5.1.15.6.2	Regulated lead acid battery power sources	62
5.1.15.6.3	Nickel cadmium or nickel metal hydride battery	62
5.1.15.6.4	Other power sources	63
5.2	Interpretation of the measurement results	63
5.3	Radio test suites	63
5.3.1	Accuracy and stability of RF carriers	63
5.3.1.1	Test environment	63
5.3.1.2	Method of measurement	63
5.3.1.3	Verdict criteria when the EUT is a RFP	64
5.3.1.4	Verdict criteria when the EUT is a PP	64
5.3.2	Accuracy and stability of timing parameters	64
5.3.2.1	Measurement of packet timing jitter	64
5.3.2.1.1	Test environment	64
5.3.2.1.2	Method of measurement	64
5.3.2.1.3	Verdict criteria	65
5.3.2.2	Measurement of the reference timing accuracy of a RFP	65
5.3.2.2.1	Test environment	65
5.3.2.2.2	Method of measurement	65
5.3.2.2.3	Verdict criteria	65
5.3.2.3	Measurement of packet transmission accuracy of a PP	66
5.3.2.3.1	Test environment	66
5.3.2.3.2	Method of measurement	66
5.3.2.3.3	Verdict criteria	67
5.3.3	Transmission burst	67
5.3.3.1	Test environment	67
5.3.3.2	Method of measurement	67
5.3.3.3	Verdict criteria	67
5.3.4	Transmitted power	68
5.3.4.1	PP and RFP with an integral antenna	68
5.3.4.1.1	Test environment	68
5.3.4.1.2	Method of measurement	68
5.3.4.1.3	Verdict criteria for all EUTs	69
5.3.4.2	PP and RFP with external antenna connection(s)	69
5.3.4.2.1	Test environment	69
5.3.4.2.2	Method of measurement	70
5.3.4.2.3	Verdict criteria for all EUTs	70
5.3.5	RF carrier modulation	70
5.3.5.1	Test environment	70
5.3.5.2	Method of measurement, parts 1 and 2	70
5.3.5.2.1	Introduction	70
5.3.5.2.2	Part 1	71
5.3.5.2.3	Part 2	71
5.3.5.3	Method of measurement, parts 3 and 4	71
5.3.5.3.0	General	71
5.3.5.3.1	Part 3	72
5.3.5.3.2	Part 4	72
5.3.5.4	Verdict criteria for part 1	72
5.3.5.5	Verdict criteria for part 2	72
5.3.5.6	Verdict criteria for part 3	72
5.3.5.7	Verdict criteria for part 4	73
5.3.6	Unwanted RF power radiation	74
5.3.6.1	General test conditions	74
5.3.6.2	Emissions due to modulation	74
5.3.6.2.1	Test environment	74
5.3.6.2.2	Method of measurement	74
5.3.6.2.3	Verdict criteria	75
5.3.6.3	Emissions due to transmitter transients	75
5.3.6.3.1	Test environment	75
5.3.6.3.2	Method of measurement	76
5.3.6.3.3	Verdict criteria	76

5.3.6.4	Emissions due to intermodulation	76
5.3.6.4.1	Test environment	76
5.3.6.4.2	Method of measurement	77
5.3.6.4.3	Verdict criteria	77
5.3.6.5	Spurious emissions when allocated a transmit channel	78
5.3.6.5.1	Radiated emissions	78
5.3.6.5.2	Conducted spurious emissions when the EUT has a permanent external antenna connector	79
5.3.7	Radio receiver testing	79
5.3.7.0	General	79
5.3.7.1	Radio receiver sensitivity	79
5.3.7.1.1	Test environment	79
5.3.7.1.2	Method of measurement	79
5.3.7.1.3	Verdict criteria	80
5.3.7.2	Radio receiver reference BER and FER	80
5.3.7.2.1	Test environment	80
5.3.7.2.2	Method of measurement	80
5.3.7.2.3	Verdict criteria	80
5.3.7.3	Radio receiver interference performance	80
5.3.7.3.1	Test environment	80
5.3.7.3.2	Method of measurement	80
5.3.7.3.3	Verdict criteria	81
5.3.7.4	Radio receiver blocking case 1: owing to signals occurring at the same time but on other frequencies	81
5.3.7.4.1	Test environment	81
5.3.7.4.2	Method of measurement	81
5.3.7.4.3	Verdict criteria	82
5.3.7.5	Radio receiver blocking case 2: owing to signals occurring at a different time	83
5.3.7.5.1	Test environment	83
5.3.7.5.2	Method of measurement	83
5.3.7.5.3	Verdict criteria	83
5.3.7.6	Receiver intermodulation performance	83
5.3.7.6.1	Test environment	83
5.3.7.6.2	Method of measurement	84
5.3.7.6.3	Verdict criteria	84
5.3.7.7	Spurious emissions when the PP has no allocated transmit channel	84
5.3.7.7.1	Test environment	84
5.3.7.7.2	Method of measurement	84
5.3.7.7.3	Verdict criteria (outside the DECT band)	85
5.3.7.7.4	Verdict criteria (inside the DECT band)	85
5.3.8	Channel access	85
5.3.8.1	Test Environment	85
5.3.8.2	FT Test Setup	85
5.3.8.2.1	General	85
5.3.8.2.2	FT Method of Measurement	86
5.3.8.2.3	FT Verdict Criteria	86
5.3.8.3	PT Test Setup	86
5.3.8.3.1	General	86
5.3.8.3.2	PT Method of Measurement	87
5.3.8.3.3	PT Verdict Criteria	87
5.3.8.4	Channel Release	87
5.3.8.4.1	General	87
5.3.8.4.2	Method of Measurement	88
5.3.8.4.3	Channel Release Verdict Criteria	88
5.3.9	WRS testing	88
5.3.9.0	General	88
5.3.9.1	Testing as a PP	89
5.3.9.2	Testing as an RFP	89
5.3.9.3	Additional requirements	89
5.3.10	Requirements for PPs with direct PP to PP communication mode	90
5.3.10.0	General	90
5.3.11	Distributed Communications	90
5.3.11.0	General	90

5.3.11.1	Testing as a PP	90
5.3.11.2	Testing as an RFP	90
5.3.11.3	Conformance.....	91
5.3.12	Higher level modulation options.....	91
5.3.12.1	General	91
5.3.12.2	Activation of higher level modulations when EUT is in Test Standby Mode	91
Annex A (informative):	Relationship between the present document and the essential requirements of Directive 2014/53/EU	92
Annex B (informative):	Procedures for test fixture calibration and for measurement of radiated spurious emissions	94
B.1	Calibration of test fixture for receiver measurements	94
B.1.0	Procedure.....	94
B.1.1	Method of measurement	94
B.2	Radiated measurements.....	95
B.2.1	General	95
B.2.2	Radiated spurious emissions.....	96
B.2.2.1	Definition.....	96
B.2.2.2	Method of measurement	96
B.2.3	Cabinet radiation	98
B.2.3.1	Definition.....	98
B.2.3.2	Method of measurement	98
Annex C (informative):	Procedure for measurement of conducted spurious emissions	99
C.1	Conducted spurious emissions	99
C.1.1	Definition	99
C.1.2	Method of measurement	99
Annex D (normative):	Measurement of BER and FER.....	101
Annex E (informative):	Procedures for the measurement of synchronization loss at the EUT by the LT	102
E.1	Description	102
E.2	Method	102
Annex F (informative):	Maximum measurement uncertainty.....	103
Annex G (informative):	Additional receiver parameters identified under article 3.2 of Directive 2014/53/EU	104
Annex H (informative):	Bibliography.....	105
Annex I (informative):	Change History	106
History		107

Intellectual Property Rights

Essential patents

IPRs essential or potentially essential to normative deliverables may have been declared to ETSI. The declarations pertaining to these essential IPRs, if any, are publicly available for **ETSI members and non-members**, and can be found in ETSI SR 000 314: "*Intellectual Property Rights (IPRs); Essential, or potentially Essential, IPRs notified to ETSI in respect of ETSI standards*", which is available from the ETSI Secretariat. Latest updates are available on the ETSI Web server (<https://ipr.etsi.org/>).

Pursuant to the ETSI Directives including the ETSI IPR Policy, no investigation regarding the essentiality of IPRs, including IPR searches, has been carried out by ETSI. No guarantee can be given as to the existence of other IPRs not referenced in ETSI SR 000 314 (or the updates on the ETSI Web server) which are, or may be, or may become, essential to the present document.

Trademarks

The present document may include trademarks and/or tradenames which are asserted and/or registered by their owners. ETSI claims no ownership of these except for any which are indicated as being the property of ETSI, and conveys no right to use or reproduce any trademark and/or tradename. Mention of those trademarks in the present document does not constitute an endorsement by ETSI of products, services or organizations associated with those trademarks.

DECT™, **PLUGTESTS™**, **UMTS™** and the ETSI logo are trademarks of ETSI registered for the benefit of its Members. **3GPP™** and **LTE™** are trademarks of ETSI registered for the benefit of its Members and of the 3GPP Organizational Partners. **oneM2M™** logo is a trademark of ETSI registered for the benefit of its Members and of the oneM2M Partners. **GSM®** and the GSM logo are trademarks registered and owned by the GSM Association.

Foreword

This draft Harmonised European Standard (EN) has been produced by ETSI Technical Committee Digital Enhanced Cordless Telecommunications (DECT), and is now submitted for the combined Public Enquiry and Vote phase of the ETSI standards EN Approval Procedure.

The present document has been prepared under the Commission's standardisation request C(2015) 5376 final [i.9] to provide one voluntary means of conforming to the essential requirements of Directive 2014/53/EU on the harmonisation of the laws of the Member States relating to the making available on the market of radio equipment and repealing Directive 1999/5/EC [i.10].

Once the present document is cited in the Official Journal of the European Union under that Directive, compliance with the normative clauses of the present document given in table A.1 confers, within the limits of the scope of the present document, a presumption of conformity with the corresponding essential requirements of that Directive and associated EFTA regulations.

The present document is part 1 of a multi-part deliverable covering the access to radio spectrum of the different DECT radio interfaces:

Part 1: "DECT, DECT Evolution and DECT ULE";

Part 2: "DECT-2020 NR".

The present document covers DECT, DECT Evolution and DECT ULE as defined by the multi-part deliverable ETSI EN 300 175 (see [1] to [4] and [i.3] to [i.6]) and by the multi-part ETSI TS 102 939 (see [i.7] and [i.8]).

Proposed national transposition dates	
Date of latest announcement of this EN (doa):	3 months after ETSI publication
Date of latest publication of new National Standard or endorsement of this EN (dop/e):	6 months after doa
Date of withdrawal of any conflicting National Standard (dow):	18 months after doa

Modal verbs terminology

In the present document "**shall**", "**shall not**", "**should**", "**should not**", "**may**", "**need not**", "**will**", "**will not**", "**can**" and "**cannot**" are to be interpreted as described in clause 3.2 of the [ETSI Drafting Rules](#) (Verbal forms for the expression of provisions).

"**must**" and "**must not**" are **NOT** allowed in ETSI deliverables except when used in direct citation.

1 Scope

The present document specifies technical characteristics and methods of measurements for equipment implementing the Digital Enhanced Cordless Telecommunications (DECT) common interface, as specified in by the multi-part technical specification ETSI EN 300 175 including the variants DECT Evolution and DECT ULE (see ETSI EN 300 175-1 [i.3] for an overview).

The present document applies to the following equipment types:

- a) Fixed Part (FP);
- b) Portable Part (PP);
- c) Cordless Terminal Adapter (CTA);
- d) Wireless Relay Station (WRS) (FP and PP combined);
- e) Hybrid Part (HyP) (a PP with capability to act as a FP to provide PP to PP communication).

These radio equipment types are capable of operating in all or any part of the frequency bands given in table 1.

Table 1: Radiocommunications service frequency bands

	Radiocommunications service frequency bands
Transmit	1 880 MHz to 1 900 MHz
Receive	1 880 MHz to 1 900 MHz

The DECT service frequency band for transmitting and receiving for all elements is 1 880 MHz to 1 900 MHz.

Details of the DECT Common Interface may be found in ETSI EN 300 175-1 [i.3], ETSI EN 300 175 parts 2 [1] to 3 [2], ETSI EN 300 175-4 [i.4], ETSI EN 300 175 parts 5 [3] to 6 [4], and ETSI EN 300 175 parts 7 [i.5] to 8 [i.6]. Further details of the DECT system may be found in the ETSI TR 101 178 [i.1].

DECT ULE implements, in addition to the DECT Common Interface, the multi-part ETSI TS 102 939 (see ETSI TS 102 939-1 [i.7] and ETSI TS 102 939-2 [i.8]).

The present document contains requirements to demonstrate that radio equipment both effectively uses and supports the efficient use of radio spectrum in order to avoid harmful interference.

NOTE: The relationship between the present document and essential requirements of article 3.2 of Directive 2014/53/EU [i.10] is given in annex A.

2 References

2.1 Normative references

References are either specific (identified by date of publication and/or edition number or version number) or non-specific. For specific references, only the cited version applies. For non-specific references, the latest version of the referenced document (including any amendments) applies.

Referenced documents which are not found to be publicly available in the expected location might be found at <https://docbox.etsi.org/Reference/>.

NOTE: While any hyperlinks included in this clause were valid at the time of publication, ETSI cannot guarantee their long term validity.

The following referenced documents are necessary for the application of the present document.

- [1] ETSI EN 300 175-2 (V2.9.1) (03-2022): "Digital Enhanced Cordless Telecommunications (DECT); Common Interface (CI); Part 2: Physical layer (PHL)".
- [2] ETSI EN 300 175-3 (V2.9.1) (03-2022): "Digital Enhanced Cordless Telecommunications (DECT); Common Interface (CI); Part 3: Medium Access Control (MAC) Layer".
- [3] ETSI EN 300 175-5 (V2.9.1) (03-2022): "Digital Enhanced Cordless Telecommunications (DECT); Common Interface (CI); Part 5: Network (NWK) layer".
- [4] ETSI EN 300 175-6 (V2.9.1) (03-2022): "Digital Enhanced Cordless Telecommunications (DECT); Common Interface (CI); Part 6: Identities and addressing".
- [5] ETSI EN 300 700 (V2.2.1) (12-2018): "Digital Enhanced Cordless Telecommunications (DECT); Wireless Relay Station (WRS)".
- [6] Recommendation ITU-T O.153 (1992): "Basic parameters for the measurement of error performance at bit rates below the primary rate".

2.2 Informative references

References are either specific (identified by date of publication and/or edition number or version number) or non-specific. For specific references, only the cited version applies. For non-specific references, the latest version of the referenced document (including any amendments) applies.

NOTE: While any hyperlinks included in this clause were valid at the time of publication, ETSI cannot guarantee their long term validity.

The following referenced documents are not necessary for the application of the present document but they assist the user with regard to a particular subject area.

- [i.1] ETSI TR 101 178: "Digital Enhanced Cordless Telecommunications (DECT); A High Level Guide to the DECT Standardization".
- [i.2] ISO/IEC 9646-1: "Information technology -- Open Systems Interconnection -- Conformance testing methodology and framework -- Part 1: General concepts".
- [i.3] ETSI EN 300 175-1: "Digital Enhanced Cordless Telecommunications (DECT); Common Interface (CI); Part 1: Overview".
- [i.4] ETSI EN 300 175-4: "Digital Enhanced Cordless Telecommunications (DECT); Common Interface (CI); Part 4: Data Link Control (DLC) Layer".
- [i.5] ETSI EN 300 175-7: "Digital Enhanced Cordless Telecommunications (DECT); Common Interface (CI); Part 7: Security features".
- [i.6] ETSI EN 300 175-8: "Digital Enhanced Cordless Telecommunications (DECT); Common Interface (CI); Part 8: Speech and audio coding and transmission".
- [i.7] ETSI TS 102 939-1: "Digital Enhanced Cordless Telecommunications (DECT); Ultra Low Energy (ULE); Machine to Machine Communications; Part 1: Home Automation Network (phase 1)".
- [i.8] ETSI TS 102 939-2: "Digital Enhanced Cordless Telecommunications (DECT); Ultra Low Energy (ULE); Machine to Machine Communications; Part 2: Home Automation Network (phase 2)".
- [i.9] Commission Implementing Decision C(2015) 5376 final of 4.8.2015 on a standardisation request to the European Committee for Electrotechnical Standardisation and to the European Telecommunications Standards Institute as regards radio equipment in support of Directive 2014/53/EU of the European Parliament and of the Council.
- [i.10] Directive 2014/53/EU of the European Parliament and of the Council of 16 April 2014 on the harmonisation of the laws of the Member States relating to the making available on the market of radio equipment and repealing Directive 1999/5/EC.
- [i.11] ETSI EN 300 176-1: "Digital Enhanced Cordless Telecommunications (DECT); Test Specification; Part 1: Radio".

- [i.12] ISO/IEC 9646-7: "Information technology -- Open Systems Interconnection -- Conformance testing methodology and framework -- Part 7: Implementation Conformance Statements".
- [i.13] ETSI EG 203 336: "Guide for the selection of technical parameters for the production of Harmonised Standards covering article 3.1(b) and article 3.2 of Directive 2014/53/EU".

3 Definition of terms, symbols and abbreviations

3.1 Terms

For the purposes of the present document, the following terms apply:

antenna diversity: feature that implies that the Radio Fixed Part (RFP) is able to select for each bearer independently different antenna properties such as gain, polarization, coverage patterns, and other features that may affect the practical coverage

NOTE: A typical example is space diversity, provided by two vertically polarized antennas separated by 10 cm to 20 cm.

bearer handover: internal handover process provided by the Medium Access Control (MAC) layer, whereby one MAC connection can modify its underlying bearers while maintaining the service provided to the Data Link Control (DLC) layer

NOTE: Bearer handover is slot based.

cell: domain served by a single antenna system (including a leaky feeder) of one FP

NOTE: A cell may include more than one source of radiated Radio Frequency energy (i.e. more than one Radio End Point).

Central Control Fixed Part (CCFP): physical grouping that contains the central control elements of one or several FPs

NOTE: An FP may be split in the control part (CCFP) and the Radio part (RFP). A CCFP may control one or more RFPs.

conducted measurements: measurements which are made using a direct connection to the equipment under test

Cordless Terminal Adapter (CTA): physical grouping that contains a DECT portable termination and a line interface

DECT Distributed communications: communication capability of a DECT Local Network that allows a number of DECT terminals (a FP and number of PPs) to co-exist and directly communicate one with another

DECT-like carrier: modulated RF DECT carrier used for interference testing which conforms to the requirements in ETSI EN 300 175-2 [1] in terms of frequency and timing and uses a pseudo-random sequence for modulation

double slot: 1/12th of a Time Division Multiple Access (TDMA) frame which is used to support one high capacity physical channel

duplex bearer: use of two simplex bearers operating in opposite directions on two physical channels

NOTE: These pairs of channels always use the same RF carrier and always use evenly spaced slots (i.e. separated by 0,5 TDMA frame).

environmental profile: range of environmental conditions under which equipment within the scope of the present document is required to comply with the provisions of the present document

Equipment Under Test (EUT): equipment submitted to the test laboratory for type examination

Fixed Part (DECT Fixed Part (FP)): physical grouping that contains all of the elements in the DECT network between the local network and the DECT air interface

NOTE: A DECT FP contains the logical elements of at least one Fixed radio Termination (FT), plus additional implementation specific elements.

Fixed radio Termination (FT): logical group of functions that contains all of the DECT processes and procedures on the fixed side of the DECT air interface

NOTE: A FT only includes elements that are defined in the DECT CI standard. This includes radio transmission elements (layer 1) together with a selection of layer 2 and layer 3 elements.

full slot: 1/24th of a TDMA frame which is used to support one physical channel

half slot: 1/48th of a TDMA frame which is used to support one physical channel

handover: process of switching a call in progress from one physical channel to another physical channel

NOTE: These processes can be internal or external. There are two physical forms of handover: intra-cell handover and inter-cell handover. Intra-cell handover is always internal. Inter-cell handover can be internal or external.

host equipment: any equipment which has a complete user functionality when not connected to the DECT radio equipment, and to which the DECT radio equipment provides additional functionality, and to which connection is necessary for the DECT radio equipment to offer functionality

Hybrid Part (HyP): DECT terminal that provides FT as well as PT capabilities being capable of communicating directly with FT or PT

inter-cell handover: switching of a call in progress from one cell to another cell

NOTE: This only defines the form of handover, it does not define a specific process.

intra-cell handover: switching of a call in progress from one physical channel of one cell to another physical channel of the same cell

NOTE: This only defines the form of handover, it does not define a specific process.

long slot: name given to the variable capacity slot when $j = 640$ or $j = 672$. The long slot has an intermediate size between the full slot and the double slot

Lower Tester (LT): logical grouping that contains the test equipment, a functionally equivalent DECT PT, a functionally equivalent DECT FT and a test controller

multiframe: repeating sequence of 16 successive TDMA frames, that allows low rate or sporadic information to be multiplexed (e.g. basic system information or paging)

nominal transceiver: electronic system or part of a system, able to transmit and receive radio signals in the frequency interval equivalent to a single DECT radio channel

peak frequency deviation: difference between the minimum and maximum extent of a frequency modulated signal, and the nominal centre or carrier frequency

physical channel: simplex channel that is created by transmitting in one particular slot on one particular RF channel in successive TDMA frames (see also simplex bearer)

NOTE: One physical channel provides a simplex service. Two physical channels are required to provide a duplex service.

physical packet: all the bits transmitted by the DECT REP in one slot time

Portable HandSet (PHS): single physical grouping that contains all of the portable elements that are needed to provide a teleservice to the user

NOTE: PHS is a subset of all possible PPs. This subset includes all physical groupings that combine one PT plus at least one portable application in a single physical box.

Portable Part (DECT Portable part (PP)): physical grouping that contains all elements between the user and the DECT air interface

NOTE: PP is a generic term that may describe one or several physical pieces. A PP is logically divided into one PT plus one or more portable applications.

Portable radio Termination (PT): logical group of functions that contains all of the DECT processes and procedures on the portable side of the DECT air interface

NOTE: A PT only includes elements that are defined in the DECT CI standard ETSI EN 300 175 parts 2 [1] to 3 [2] and ETSI EN 300 175 parts 5 [3] to 6 [4]. This includes radio transmission elements together with a selection of layer 2 and layer 3 elements.

provision mandatory, process mandatory: means that the indicated feature service or procedure is to be implemented necessarily as described in the referenced document

provision optional, process mandatory: means that the indicated feature, service or procedure may be implemented, and if implemented, the feature, service or procedure is to be implemented necessarily as described in the referenced document

NOTE: The used notation is based on the notation proposed in ISO/IEC 9646-7 [i.12].

radiated measurements: measurements which involve the absolute measurement of a radiated field

Radio End Point (REP): physical grouping that contains one radio transmitter/receiver, fixed or portable

NOTE: A REP may operate only as a receiver or only as a transmitter.

Radio Fixed Part (RFP): one physical sub-group of a FP that contains all the REPs (one or more) that are connected to a single system of antennas

repeater: DECT device that allows extension of the range between a Portable Part and a Fixed Part

simplex bearer: MAC layer service that is created using one physical channel

TDMA frame: time-division multiplex of 10 ms duration, containing 24 successive full slots

NOTE: A TDMA frame starts with the first bit period of full slot 0 and ends with the last bit period of full slot 23.

test laboratory: body which performs conformance testing

NOTE: This laboratory is accredited to perform 3rd party testing.

test load: substantially non-reactive, non-radiating power attenuator which is capable of safely dissipating the power from the transmitter(s)

Test Standby Mode (TSM): configurable mode of the EUT that allows it to recognize and execute MAC test commands

NOTE 1: The Test Standby Mode is the base test mode after activation or after reception of the message 'clear test modes'. Once in TSM, other test modes may be activated by the reception of proper test messages.

NOTE 2: See ETSI EN 300 175-3 [2], clause 12.2.

Upper Tester (UT): logical grouping that controls the EUT when under test

NOTE: Commands are sent from the LT to the UT to place the EUT in the appropriate test mode.

variable capacity slot: slot structure that allows implementing slot lengths different of the half, full and double structures

NOTE: A variable capacity slot may have a duration of $100+j$ or $104+j$ data symbols with j ranging from zero to 856.

Wireless Relay Station (WRS): particular type of repeater defined by ETSI EN 300 700 [5]

3.2 Symbols

For the purposes of the present document, the following symbols apply:

dB	deciBel
BT	Bandwidth Time product
C	Conditional
dBi	dB isotropic
dBm	dB relative to 1 mW
P_{NTP}	Maximum transmit power per simultaneously active transceiver
U	Unconditional

3.3 Abbreviations

For the purposes of the present document, the following abbreviations apply:

AC	Alternate Current
AM	Amplitude Modulation
BER	Bit Error Ratio
CCFP	Central Control Fixed Part
CI	Common Interface
CRC	Cyclic Redundancy Check
CTA	Cordless Terminal Adapter
CW	Continuous Wave
D8PSK	Differential 8 Phase Shift Keying
DBPSK	Differential Binary Phase Shift Keying
DC	Direct Current
DECT	Digital Enhanced Cordless Telecommunications
DQPSK	Differential Quaternary Phase Shift Keying
DSV	Digital Sum Variation
EIRP	Equivalent Isotropically Radiated Power
EMC	ElectroMagnetic Compatibility
ERP	Effective Radiated Power
EUT	Equipment Under Test
FER	Frame Error Ratio
FP	Fixed Part
FT	Fixed radio Termination
GFSK	Gaussian Frequency Shift Keying
HyP	Hybrid Part
LT	Lower Tester
LV	Low Voltage
MAC	Medium Access Control
MAX	Maximum
MIN	MINimum
NOM	NOMinal
NTP	Normal Transmitted Power
PHL	PHysical Layer
PHS	Portable HandSet
PP	Portable Part
ppm	parts per million
PRI	Pulse Repetition Interval
PT	Portable radio Termination
QAM	Quadrature Amplitude Modulation
REP	Radio End Point
RF	Radio Frequency
RFP	Radio Fixed Part
RFPI	Radio Fixed Part Identity
RH	Relative Humidity
RX	Receiver or receiving side
TDMA	Time Division Multiple Access
TSM	Test Standby Mode

TSP	Test Support Profile
TX	Transmitter or transmitting side
ULE	Ultra Low Energy
UT	Upper Tester
VSWR	Voltage Standing Wave Ratio
WRS	Wireless Relay Station

4 Technical requirements specifications

4.1 Environmental profile

The technical requirements of the present document apply under the environmental profile for operation of the equipment, which shall be in accordance with its intended use. The equipment shall comply with all the technical requirements of the present document at all times when operating within the boundary limits of the operational environmental profile defined by its intended use.

4.2 Overview

4.2.0 General

The test cases described in clause 4.2 are intended to follow the ISO/IEC 9646-1 [i.2] recommendations as closely as possible. However, for practical reasons it is not always possible to follow the guidelines exactly and the following clauses describe the relationship of the present document to ISO/IEC 9646-1 [i.2].

4.2.1 Test suites

The term "test suite" is defined in ISO/IEC 9646-1 [i.2].

Table 2 lists the test suite that is described in the present document and the test groups that are associated with it.

Table 2: Test suite

Test suite	Test groups
DECT Physical Layer (PHL)	Physical layer services
	Transmission of physical packets
	Reception of physical packets
	Channel access
	WRS
	PP to PP communication
	Direct communication
	Higher level modulation

4.2.2 Test groups

The term "test group" is defined in ISO/IEC 9646-1 [i.2].

Table 3 lists the test groups that are described in the present document and the test cases that are associated with them.

Table 3: Test groups

Test group	Test cases
Physical layer services	1, 2, 3, 4
Transmission of physical packets	5, 6, 7, 8, 9, 10, 11, 12
Reception of physical packets	13, 14, 15, 16, 17, 18, 19
Channel access	20
WRS	21
PP to PP communication	22
Direct communication	23
Higher level modulation	24

4.2.3 Test cases

The term "test case" is defined in ISO/IEC 9646-1 [i.2], clause 3.3.

Table 4 lists the test cases that are described in the present document.

Table 4: Test cases

Test case	Technical requirement	Clause number
1	Accuracy and stability of RF carriers	4.5.1
2	Timing jitter: slot-slot on the same channel	4.5.2
3	Reference timing accuracy of an RFP	4.5.2
4	Measurement of packet timing accuracy	4.5.2
5	Transmission Burst	4.5.3
6	Transmitted power: PP and RFP with an integral antenna	4.5.4.1.1
7	Transmitted power: PP and RFP with an external antenna connector	4.5.4.1.2
8	RF carrier modulation	4.5.5
9	Emissions due to modulation	4.5.6.2
10	Emissions due to transmitter transients	4.5.6.3
11	Emissions due to intermodulation	4.5.6.4
12	Spurious emissions when allocated a transmit channel	4.5.6.5
13	Radio receiver sensitivity	4.5.7.1
14	Radio receiver reference Bit Error Ratio (BER) and Frame Error Ratio (FER)	4.5.7.2
15	Radio receiver interference performance	4.5.7.3
16	Radio receiver blocking case 1	4.5.7.4
17	Radio receiver blocking case 2	4.5.7.5
18	Receiver intermodulation performance	4.5.7.6
19	Spurious emissions when the radio endpoint has no allocated transmit channel	4.5.7.7
20	Channel access	4.5.8
21	WRS	4.5.9
22	PP to PP communication	4.5.10
23	Direct communication	4.5.11
24	Higher level modulation	4.5.12

4.3 Product information for testing

4.3.1 Information on capabilities and options implemented

An Implementation Conformance Statement shall contain the following information, relevant for testing:

- Support or no support of Higher Level Modulation Schemes (as defined by ETSI EN 300 175-2 [1], annex D)
- Support or no support of Direct PP to PP Communication mode (as defined by ETSI EN 300 175-3 [2], annex G)
- Support or no support of ULE capabilities (as defined by ETSI TS 102 939-1 [i.7] and ETSI TS 102 939-2 [i.8])

- Support or no support of WRS capabilities (as defined by ETSI EN 300 700 [5])
- Support or no support of no-emission mode (as defined by ETSI EN 300 175-3 [2], clause 9.4)

If the equipment supports Higher Level Modulation Schemes, the Implementation Conformance Statement shall provide information on which schemes are supported (see clause 5.3.12.2).

4.3.2 Additional information on implementation for testing

Additional information on implementation for testing shall include or reference all of the information related to the EUT and its testing environment, which will enable the test laboratory to run an appropriate test suite against the EUT.

This shall include:

- the method by which the equipment can be switched into the Test Standby Mode (TSM). This mode is described in clause 5.1.10.2;
- whether the equipment has one or more internal or external antennas;
- whether the equipment has antenna diversity.
- If the equipment supports Higher Level Modulation Schemes, the activation method shall be described (see clause 5.3.12.2).

4.4 Applicability of tests

4.4.0 Introduction

The applicability of the individual test suite in the present document is dependent on the type of equipment. Equipment may contain one or more of the features listed in the following clauses. It is assumed that all equipment contains a radio receiver. The tests described in the present document shall only be applied to the equipment physically containing a DECT RF receiver and/or transceiver. Control lines to the EUT necessary for its operation shall be permitted.

4.4.1 Equipment that includes only a DECT RF receiver

The tests are specified in clause 5.3.7.

4.4.2 Equipment that includes a radio transmitter

The tests are specified in clauses 5.3.1, 5.3.2, 5.3.3, 5.3.4, 5.3.5, 5.3.6, 5.3.7 and 5.3.8. For equipment continuously transmitting (e.g. FP with dummy bearer) the test specified in clause 5.3.7.7 shall not apply.

4.4.3 CTAs

The requirements for PPs apply to Cordless Terminal Adapters (CTAs).

4.4.4 Equipment with combined FT and PT functionality

4.4.4.0 General

Equipment that is able to operate both as an RFP and as a PP shall meet the conformance requirements of the present document for an RFP when operating as an RFP and for a PP when operating as a PP.

There are however three basic types of equipment with combined FT and PT functionality using a single common radio, which have been standardized. The notations for these types of equipment are Wireless Relay Stations, WRSs, see ETSI EN 300 700 [5], Direct PP to PP communication, see ETSI EN 300 175-3 [2], annex G, and Distributed Communications, see ETSI EN 300 175-5 [3], annex I. For these the requirements described in clauses 4.4.4.1, 4.4.4.2 and 4.4.4.3 shall apply.

4.4.4.1 Wireless Relay Station

Wireless Relay Stations (WRSs), see ETSI EN 300 700 [5], provide relaying between FT and PT operating simultaneously. A WRS belongs to a specific DECT system, and has to be registered and locked to this system to operate.

WRSs shall conform to the requirements of clause 4.5.9.

A WRS conforms to a defined frame multiplexing scheme, see ETSI EN 300 700 [5], which provides a transparent digital bit pipe for the user data, and which automatically provides an acceptable upper bound of the incremental delay introduced by a WRS.

4.4.4.2 Direct PP to PP communication

Direct PP to PP communication, see ETSI EN 300 175-3 [2], annex G, is a notation for a PP (or CTA) feature that provides ad hoc networking with specific temporary system ad hoc identities. A PP temporarily switches into FT mode to provide direct access to any of the other PPs of the ad hoc network. There is no requirement or need to being locked to an RFP. Since no RFP is involved in the communication link, direct PP to PP communication only uses half the spectrum compared to normal calls routed via RFPs.

PPs and CTAs with direct PP to PP communication option shall conform to the requirements of clause 4.5.10.

4.4.4.3 Distributed Communications

Distributed communications, ETSI EN 300 175-5 [3], annex I, is a notation for a DECT system feature providing direct links between PPs (or CTAs). Such PPs and CTAs are also called Hybrid Parts, HyP. The HyPs always stay in lock with the DECT system and an RFP is always involved in the direct link connection. Either just by providing the locking and time synchronization, or also by direct involvement in the set up procedure. The main target application is data local networking. Since no RFP is involved in the user communication link, the distributed communications option only uses half the spectrum compared to normal calls routed via RFPs.

PPs and CTAs with distributed communications option, HyPs, shall conform to the requirements of clause 4.5.11.

4.4.5 Equipment that is capable of using higher level modulation

Equipment is allowed to use 4-level, 8-level, 16-level and/or 64-level modulation in addition to the mandatory 2-level modulation. This will increase the bit rate of single radio DECT equipment by a factor 2 to 6, which allows for 4 Mbit/s services.

Such equipment shall conform to the requirements of clause 4.5.12.

4.4.6 Equipment supporting additional carriers

For EUTs supporting additional carriers (see clause 4.5.1.1) the various tests cases shall be performed, where relevant, on the two band edge carriers and on one carrier inside the band.

4.5 Conformance requirements

4.5.1 Accuracy and stability of RF carriers

4.5.1.1 Definition

Ten RF carriers shall be placed into the frequency band 1 880 MHz to 1 900 MHz with centre frequencies F_c given by:

$$F_c = F_0 - c \times 1,728 \text{ MHz};$$

where

$$F_0 = 1\,897,344 \text{ MHz};$$

and

$$c = 0, 1, \dots, 9.$$

Above this band, additional carriers are defined with centre frequencies F_c given by:

$$F_c = F_9 + c \times 1,728 \text{ MHz};$$

and $c \geq 10$ and RF band = 00001 (see ETSI EN 300 175-3 [2], clause 7.2.3.3).

The frequency band between $F_c - 1,728/2$ MHz and $F_c + 1,728/2$ MHz shall be designated RF channel c .

NOTE: A nominal DECT RF carrier is one whose centre frequency is generated by the formula:
 $F_g = F_0 - g \times 1,728$ MHz,
 where g is any integer.

All DECT equipment shall be capable of working on all 10 RF channels, $c = 0, 1, \dots, 9$.

4.5.1.2 Limits

At an RFP the transmitted RF carrier frequency corresponding to RF channel c shall be in the range $F_c \pm 50$ kHz at extreme conditions.

At a PP the centre frequency accuracy shall be within ± 50 kHz at extreme conditions either relative to an absolute frequency reference or relative to the received carrier, except that during the first 1 s after the transition from the idle-locked state to the active-locked state the centre frequency accuracy shall be within ± 100 kHz at extreme conditions relative to the received carrier.

NOTE: The above state transition is defined in ETSI EN 300 175-3 [2].

The maximum rate of change of the centre frequency at both the RFP and the PP while transmitting, shall not exceed 15 kHz per slot.

4.5.1.3 Conformance

Conformance tests as defined in clause 5.3.1 shall be carried out.

4.5.2 Accuracy and stability of timing parameters

4.5.2.0 General

The requirements given in ETSI EN 300 175-2 [1], clauses 4.2.1, 4.2.2, 4.2.3 and 4.2.4 shall apply.

4.5.2.1 Definitions

4.5.2.1.1 Slot structure

To access the medium in time, a regular TDMA structure is used. The structure repeats in frames of 11 520 symbols, and the data is transmitted at a symbol rate of 1 152 ksymbol/s. Within this frame 24 full-slots are created, each consisting of two half-slots. A double slot has a length of two full slots, and starts concurrently with a full slot. The detailed slot structure is defined in in ETSI EN 300 175-2 [1], clause 4.2.1.

4.5.2.1.2 Definition of the position of p0

The start of bit p0 is defined to occur at the point in time 16 bit periods before the instant at which the modulated carrier passes through the nominal channel frequency immediately prior to the deviation corresponding to the bit p16. The bit p16 is the first bit of the packet synchronization word for the EUT as defined in ETSI EN 300 175-2 [1], clause 4.6. A Lower Tester (LT), see figure 17, can be used for the determination of the position of the packet synchronization word.

The measurement uncertainties given in annex F, table F.1 should be taken into account.

NOTE: It is not the point in time at which a receiver determines the presence of bit p0.

4.5.2.2 Limits

4.5.2.2.1 Reference timer accuracy and stability

The reference timer of a RFP or a PP is a notional clock to which the timing parameters of the TDMA framing are related.

A PP shall have its reference timer stability and accuracy better than 25 ppm at extreme conditions.

RFPs that can work with more than one duplex pair of physical channels per frame are known as multi-channel RFPs. Single channel RFPs can only work with one duplex pair of physical channels per frame (excluding handover situations).

A multi-channel RFP shall have its reference timer stability and accuracy better than 5 ppm and better than 10 ppm at extreme conditions.

A single channel RFP shall have reference timer stability and accuracy better than 10 ppm at extreme conditions.

4.5.2.2.2 RFP transmission jitter

The nominal time when a packet should occur at the RFP antenna is (by this definition) synchronous to the RFP reference timer.

The jitter of a RFP packet transmission in a slot refers to the occurrence at the antenna of the start of symbol p0 of that packet. The jitter is defined in relation to the reference timer of that RFP.

The jitter of a packet transmission shall be less than $\pm 1 \mu\text{s}$ at extreme conditions.

The jitter between p0 and every other symbol in a packet shall be within $\pm 0,1 \mu\text{s}$.

NOTE: $0,1 \mu\text{s}$ corresponds to 250 ppm.

4.5.2.2.3 PP reference timer synchronization

A PP shall take its reference timer parameters, including half-slot, full-slot, frame, multi-frame and receiver scan (see synchronization, ETSI EN 300 175-3 [2], annex D) from any channel of any of the RFPs that it is locked to.

It is allowed (but not required) to have more than one PP reference timer.

The reference timer used for a PP transmission to a RFP shall be synchronized to packets (see clause 4.5.4.1.2) received from that RFP or from a RFP to which internal handover is allowed.

This reference timer for packet transmission timing is nominally (by this definition) synchronized to the time when the last packet used for synchronization occurred at the PP antenna.

When a PP transmits a packet, the start of transmission of symbol p0 of the packet shall occur at the PP antenna $\pm 2 \mu\text{s}$ at extreme conditions from the nominal transmission time as given by an ideal PP reference timer with 0 ppm accuracy. An exception is allowed for a dummy bearer change request packet transmission (see ETSI EN 300 175-3 [2], clause 7.2.5.6), when the nominal transmission time shall be given by the actual PP reference timer.

NOTE: The reason for the exception is that a residential PP may need to send the dummy bearer change request after a sudden slot theft in the idle locked mode. In this case the last synchronization of the reference timer can be more than 16 frame old. For all other packet transmissions, including bearer set up, the synchronization is normally less than one frame old.

The jitter between p0 and every other symbol in a packet shall be within $\pm 0,1 \mu\text{s}$.

Connections to different RFPs are allowed (but not required) to have different reference timers.

4.5.2.3 Conformance

Conformance tests as defined in clause 5.3.2 shall be carried out.

4.5.3 Transmission burst

4.5.3.1 Definitions

4.5.3.1.0 Introduction

The transmission requirements are defined in clauses 4.5.3.1.2 to 4.5.3.1.9 and graphically represented in figure 1.

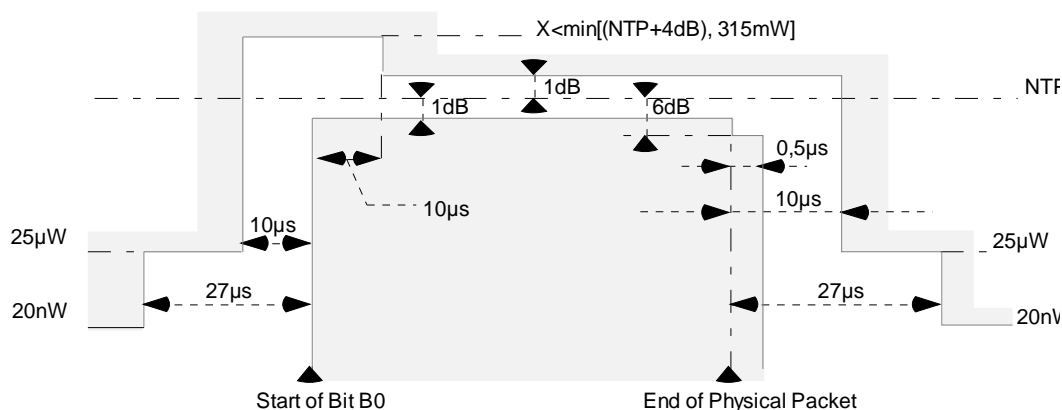

Figure 1: Physical packet power-time template

4.5.3.1.1 Physical packets

The term "physical packet" used in the present document refers to all the bits transmitted by the DECT REP in one slot time. The timing of the physical packet relative to the power-time template should be conditioned by the absolute packet timing measurement uncertainty in annex F.

4.5.3.1.2 Transmitted power

This is the mean power delivered over one radio frequency cycle.

4.5.3.1.3 Normal Transmitted Power (NTP)

The NTP is the transmitted power averaged from the start of bit p0 of the physical packet to the end of the physical packet.

4.5.3.1.4 Transmitter attack time

This is the time taken for the transmitted power to increase from $25 \mu\text{W}$ to the time that the first bit of the physical packet, p0, starts transmission.

4.5.3.1.5 Transmitter release time

This is the time, taken from the end of the physical packet, for the transmitted power to decrease to 25 μ W.

4.5.3.1.6 Minimum power

This is the minimum transmitted power from the first bit of the packet, p0, to the end of the physical packet. The limit given in clause 4.5.3.2.3.

4.5.3.1.7 Maximum power

This is the maximum transmitted power from 10 μ s after the start of symbol p0 to 10 μ s after the end of the physical packet. A second special limit (allowance for transients) applies from 10 μ s before the start of symbol p0 to 10 μ s after the start of symbol p0. The limit values are given in clause 4.5.3.2.4. The maximum allowed measurement uncertainty as described in annex F applies.

4.5.3.1.8 Maintenance of transmission after packet end

The transmitted power as measured shall be maintained after the end of the physical packet as defined in clause 4.5.3.2.5.

4.5.3.1.9 Transmitter idle power output

This is the transmitter idle power for the time period starting 27 μ s after the end of the physical packet, and finishing 27 μ s before the next transmission of data bit p0. The limit value is given in clause 4.5.3.2.6. The maximum allowed measurement uncertainty as described in annex F applies.

4.5.3.2 Limits

4.5.3.2.1 Transmitter attack time

The transmitter attack time shall be less than 10 μ s at extreme conditions.

4.5.3.2.2 Transmitter release time

The transmitter release time shall be less than 10 μ s at extreme conditions.

4.5.3.2.3 Minimum power

From the first symbol of the packet, p0, to the end of the physical packet, the transmitted power shall be greater than (NTP - 1 dB) at extreme conditions.

4.5.3.2.4 Maximum power

- a) From 10 μ s after the start of symbol p0 to 10 μ s after the end of the physical packet, the transmitted power shall be less than (NTP + 1 dB) at extreme conditions.
- b) From 10 μ s before the start of symbol p0 to 10 μ s after the start of symbol p0, the transmitted power shall be less than (NTP + 4 dB) and less than 315 mW at extreme conditions.

4.5.3.2.5 Maintenance of transmission after packet end

The transmitted power shall be maintained greater than (NTP - 6 dB) for 0,5 μ s after the end of the physical packet at extreme conditions.

4.5.3.2.6 Transmitter idle power output

For the time period starting 27 μ s after the end of the physical packet and finishing 27 μ s before the next transmission of a data symbol p0, the transmitter idle power shall be less than 20 nW, except when p0 of the next transmitted packet occurs less than 54 μ s after the end of the transmitted physical packet.

4.5.3.3 Conformance

Conformance tests as defined in clause 5.3.3 shall be carried out.

4.5.4 Transmitted power

4.5.4.1 Definitions

4.5.4.1.0 Transceiver and P_{NTP} definitions

4.5.4.1.0.1 Nominal transceiver definition

All occurrences of the term "transceiver" in the present document, unless otherwise specifically indicated, shall be understood as referring to a "nominal transceiver" with the following definition:

"Nominal transceiver" is the electronic system or part of a system, able to transmit and receive radio signals in the frequency interval equivalent to a single DECT radio channel.

A DECT radio channel is defined as any 1,728 MHz frequency interval centered in any of the DECT carrier frequencies defined in ETSI EN 300 175-2 [1], clause 4.1.1.

Any electronic system able to transmit and receive radio signals simultaneously in an interval of more than one DECT radio channel is considered a multiple transceiver system for the purpose of the present document, irrespective of the physical implementation.

4.5.4.1.0.2 P_{NTP} definition

P_{NTP} is defined as the maximum transmit power in a given instant of time per simultaneously active nominal transceiver.

4.5.4.1.1 PP and RFP with an integral antenna

The present clause shall apply if the EUT incorporates an integral antenna.

The NTP shall be less than P_{NTP} per simultaneously active transceiver at nominal test conditions.

The power measured at a temporary connector is the NTP.

4.5.4.1.2 PP and RFP with external connections for all antennas

The present clause shall apply if the EUT provides an external antenna connector.

For a radio end point with more than one antenna port, the instantaneous power from each antenna port shall be added together to give the NTP.

The NTP shall be less than P_{NTP} per simultaneously active transceiver at nominal test conditions.

4.5.4.1.3 PP and RFP with both integral and external antennas

The present clause shall apply if the EUT incorporates an integral antenna and provides an external antenna connector.

If the integral and external antennas are not transmitting simultaneously then the test cases described in clauses 5.3.4.1 and 5.3.4.2 shall be applied independently. The appropriate antenna is selected using the test message referenced in clause 5.1.10.3.

If the integral and external antennas are transmitting simultaneously then both clauses 5.3.4.1 and 5.3.4.2 shall be applied and the results shall be added to give the NTP.

4.5.4.2 Limits

P_{NTP} is 250 mW, equal to 24 dBm. The antenna gain of integral antennas shall be less than $(12 \text{ dBi} + X)$, where X is the difference in dB between 24 dBm and the NTP expressed in dBm for any one active transceiver. The antenna gain of $(12 \text{ dBi} + X)$ corresponds to an EIRP of 4W (36 dBm).

4.5.4.3 Conformance

Conformance tests as defined in clause 5.3.4 shall be carried out.

4.5.4.4 Multi-transceiver systems

For systems implementing multiple transceivers, with the definition of transceiver given in clause 4.5.4.1.0.1, the limit of 250 mW, 24 dBm shall be understood as per nominal transceiver. In case of simultaneous transmission over several DECT radio channels on the same time interval, the compound power will be the combination of the P_{NTP} of each simultaneously active nominal transceiver.

4.5.5 RF carrier modulation

4.5.5.1 Definition

The modulation method shall be Gaussian Frequency Shift Keying (GFSK) with a bandwidth-bit period product of nominally 0,5 and a nominal peak deviation (f) of 288 kHz.

A binary "1" is encoded with a peak frequency deviation of $(+f)$, giving a peak transmit frequency of $(F_c + f)$, which is greater than the carrier frequency of (F_c) . A binary "0" is encoded with a peak frequency deviation of $(-f)$, giving a peak transmit frequency of $(F_c - f)$.

For High level modulation options, see clause 4.5.12.

4.5.5.2 Limits

The achieved deviation in any given PP or RFP may vary from this nominal value as follows:

NOTE 1: These limits apply equally to positive and negative deviations.

- Case A: Case A shall apply to the transmission of a repeating binary sequence of four "1"s and four "0"s:
 -000011110000111100001111....
 - The deviation limits for case A shall be:
 - peak deviation greater than 259 kHz (90 % of nominal);
 - peak deviation less than 403 kHz (140 % of nominal).
- Case B: Case B shall apply to the transmission of all other binary sequences (sequences both longer and shorter than case A) that contain a maximum "digital sum variation" (see note 3) with an absolute value equal to or less than sixty four:
 - The deviation limits for case B shall be:
 - peak deviation greater than 202 kHz (70 % of nominal);
 - peak deviation less than 403 kHz (140 % of nominal).

NOTE 2: Case B includes the case of a ".1010." sequence.

NOTE 3: "Digital Sum Variation" (DSV) is defined as the cumulative total of all transmitted symbols, counted from the start of the transmission burst. A binary "1" counts as (+1); a binary "0" as (-1). The DSV total indicates the cumulative DC balance of the transmitted symbols.

4.5.5.3 Conformance

Conformance tests as defined in clause 5.3.5 shall be carried out.

4.5.6 Unwanted RF power radiation

4.5.6.1 General

If the EUT is equipped with antenna diversity, the EUT shall have the diversity operation defeated for the following tests (see clause 5.1.10.3 for the appropriate test message reference).

4.5.6.2 Emissions due to modulation

4.5.6.2.1 Definition

The unwanted emission(s) due to modulation is the power measured in any DECT RF channel other than the one in which the EUT is transmitting, integrated over a bandwidth of 1 MHz.

4.5.6.2.2 Limits

With transmissions on physical channel Ra (K, L, M, N) in successive frames, the power in physical channel Ra (K, L, Y, N) shall be less than the values given in table 5.

Table 5: Emissions modulation

Emissions on RF channel "Y"	Maximum power level
$Y = M \pm 1$	160 μ W
$Y = M \pm 2$	1 μ W
$Y = M \pm 3$	80 nW
Y = any other DECT channel	40 nW
NOTE: For Y = "any other DECT channel", the maximum power level shall be less than 40 nW except for one instance of a 500 nW signal.	

The power in RF channel Y is defined by integration over a bandwidth of 1 MHz centered on the nominal centre frequency, F_y , averaged over at least 60 % but less than 80 % of the physical packet, and starting before 25 % of the physical packet has been transmitted but after the synchronization word.

4.5.6.2.3 Conformance

Conformance tests as defined in clause 5.3.6.2 shall be carried out.

4.5.6.3 Emissions due to transmitter transients

4.5.6.3.1 Definition

The power level of all modulation products (including AM components due to the switching on or off of the modulated RF carrier) in a DECT RF channel as a result of a transmission on another DECT RF channel.

4.5.6.3.2 Limits

The power level of all modulation products (including Amplitude Modulation (AM) products due to the switching on or off of a modulated RF carrier) arising from a transmission on RF channel M shall, when measured using a peak hold technique, be less than the values given in table 6. The measurement bandwidth shall be 100 kHz and the power shall be integrated over a 1 MHz bandwidth centered on the DECT frequency, F_y .

Table 6: Emissions due to transmitter transients

Emissions on RF channel "Y"	Maximum power level
$Y = M \pm 1$	250 μ W
$Y = M \pm 2$	40 μ W
$Y = M \pm 3$	4 μ W
Y = any other DECT channel	1 μ W

4.5.6.3.3 Conformance

Conformance tests as defined in clause 5.3.6.3 shall be carried out.

4.5.6.4 Emissions due to intermodulation

4.5.6.4.1 Definition

The power level of intermodulation products that are on any DECT physical channel when any combination of the transmitters at a radio FP or portable part are in calls on the same slot on different frequencies.

4.5.6.4.2 Limits

The power level of intermodulation products that are on any DECT physical channel when any combination of the transmitters at a radio end point are in calls on the same slot on different frequencies shall be less than 1 μ W. The power level is defined by integration over the 1 MHz centered on the nominal centre frequency of the afflicted channel and averaged over the time period in clause 4.5.6.2.2.

4.5.6.4.3 Conformance

Conformance tests as defined in clause 5.3.6.4 shall be carried out.

4.5.6.5 Spurious emissions when allocated a transmit channel

4.5.6.5.1 Definition

The peak power level of any RF emissions outside the radio frequency band allocated to DECT when a radio endpoint has been allocated a transmit channel. If a REP has more than one transceiver, any out of band transmitter intermodulation products shall also be included.

The limits and conformance requirements cover two kinds of emissions, radiated and conducted spurious emissions.

4.5.6.5.2 Limits

The peak power level of any RF emissions outside the radio frequency band allocated to DECT, as defined in clause 4.1.1 of ETSI EN 300 175-2 [1], when a radio end point has an allocated physical channel, shall not exceed 250 nW at frequencies below 1 GHz and 1 μ W at frequencies above 1 GHz. The power shall be defined in the bandwidths given in table 7. If a radio end point has more than one transceiver, any out of band transmitter intermodulation products shall also be within these limits.

Table 7: Measurement bandwidth

Frequency offset, f_o From edge of band	Measurement bandwidth
$0 \text{ MHz} \leq f_o < 2 \text{ MHz}$	30 kHz
$2 \text{ MHz} \leq f_o < 5 \text{ MHz}$	30 kHz
$5 \text{ MHz} \leq f_o < 10 \text{ MHz}$	100 kHz
$10 \text{ MHz} \leq f_o < 20 \text{ MHz}$	300 kHz
$20 \text{ MHz} \leq f_o < 30 \text{ MHz}$	1 MHz
$30 \text{ MHz} \leq f_o < 12,75 \text{ GHz}$	3 MHz

Measurements shall not be made for transmissions on the RF channel closest to the nearest band edge for frequency offsets of up to 2 MHz.

In addition, not regarding up to 2 instances of a continuous-wave spurious signal for PPs for which the total peak power level shall be less than 250 nW as measured in a 3 MHz measurement bandwidth, the peak power level shall be less than 20 nW in a 100 kHz measuring bandwidth for the following broadcast bands:

- 47 MHz to 74 MHz;
- 87,5 MHz to 108 MHz;
- 108 MHz to 118 MHz;
- 174 MHz to 230 MHz;
- 470 MHz to 862 MHz.

4.5.6.5.3 Conformance

Conformance tests as defined in clause 5.3.6.5 shall be carried out.

4.5.7 Radio receiver testing

4.5.7.0 General

All radio receiver testing shall be performed as conducted measurements only to ensure result accuracy and consistency is maintained throughout the test cycles.

4.5.7.1 Radio receiver sensitivity

4.5.7.1.1 Definition

The radio receiver sensitivity is defined as the power level at the receiver input at which the Bit Error Ratio (BER) is 0,001 in the D-field.

4.5.7.1.2 Limits

The radio receiver sensitivity shall be -83 dBm, or better. This limit shall be met for a reference DECT radio end point transmitted frequency error of ± 50 kHz for PPs and RFPs.

This requirement shall be met with the radio end point under test operating in time division duplex mode with a reference DECT radio end point.

Before using a DECT physical channel for transmission or reception, the receiver shall be able to measure the signal levels on that physical channel, that are received stronger than -93 dBm and weaker than -33 dBm with a resolution of better than 6 dB. Signals that are received weaker than -93 dBm shall produce a result equal to, or less than that produced by a signal of -93 dBm. Signals that are received stronger than -33 dBm shall produce a result equal to, or greater than that produced by a signal of -33 dBm.

4.5.7.1.3 Conformance

Conformance tests as defined in clause 5.3.7.1 shall be carried out.

4.5.7.2 Radio receiver reference BER and FER

4.5.7.2.1 Definition

The radio receiver reference BER and FER is the maximum allowed BER and FER for a power level at the receiver input of -73 dBm or greater.

4.5.7.2.2 Limits

The reference BER is 0,00001 in the D-field. The reference FER is 0,0005.

4.5.7.2.3 Conformance

Conformance tests as defined in clause 5.3.7.2 shall be carried out.

4.5.7.3 Radio receiver interference performance

4.5.7.3.1 Definition

The ability of DECT equipment to continue receiving in the presence of an interfering signal on the same or different DECT RF channel.

4.5.7.3.2 Limits

With a received signal level of -73 dBm on RF channel M, the BER in the D-field shall be maintained better than 0,001 when a modulated, reference DECT interferer of the indicated signal level is introduced on the DECT RF channels shown in table 8.

Table 8: Receiver interference performance

Interferer on RF channel "Y":	Interferer signal level (dBm)
Y = M	-84
Y = M ± 1	-60
Y = M ± 2	-39
Y = any other DECT channel	-33
NOTE: The RF carriers "Y" shall include the three nominal DECT RF carrier positions immediately outside each edge of the DECT band.	

4.5.7.3.3 Conformance

Conformance tests as defined in clause 5.3.7.3 shall be carried out.

4.5.7.4 Radio receiver blocking case 1: owing to signals occurring at the same time but on other frequencies

4.5.7.4.1 Definition

The receiver should work in the presence of strong signals on other frequencies. These interferers may be modulated carriers or single continuous - wave carriers.

NOTE: The operation in the presence of DECT modulated signals is described in clause 4.5.7.3.

4.5.7.4.2 Limits

With the desired signal set at -80 dBm, the BER shall be maintained below 0,001 in the D-field in the presence of any one of the signals shown in table 9.

The receiver shall operate on a frequency band allocation with the low band edge F_L MHz and the high band edge F_U MHz.

Table 9: Receiver blocking

Frequency (f)	Continuous wave interferer level (dBm)
$25 \text{ MHz} \leq f < F_L - 100 \text{ MHz}$	-23
$F_L - 100 \text{ MHz} \leq f < F_L - 5 \text{ MHz}$	-33
$ f - F_C > 6 \text{ MHz}$	-43
$F_U + 5 \text{ MHz} < f \leq F_U + 100 \text{ MHz}$	-33
$F_U + 100 \text{ MHz} < f \leq 12,75 \text{ GHz}$	-23

4.5.7.4.3 Conformance

Conformance tests as defined in clause 5.3.7.4 shall be carried out.

4.5.7.5 Radio receiver blocking case 2: owing to signals occurring at a different time

4.5.7.5.1 Definition

When a high level interferer is present in a physical channel other than the one the receiver is on, the receiver is able to continue receiving the desired signal.

4.5.7.5.2 Limits

With a signal level of -14 dBm incident on the receiver in slot "N" on RF carrier "M", the receiver shall be able to receive at -83 dBm, and with the BER in the D-field maintained better than 0,001, on slot (N + 2) modulo 24 on any DECT RF carrier.

4.5.7.5.3 Conformance

Conformance tests as defined in clause 5.3.7.5 shall be carried out.

4.5.7.6 Receiver intermodulation performance

4.5.7.6.1 Definition

With a call set-up on a particular physical channel, two interferers are introduced so that they can produce an intermodulation product on the physical channel already in use.

If RF carrier number "d" is in use, a reference DECT interferer and a continuous wave interferer are introduced on DECT carriers "e" and "f" to produce an intermodulation product on carrier "d". Neither "e" nor "f" shall be adjacent to "d".

4.5.7.6.2 Limits

The received level of carriers "e" and "f" shall be -48 dBm and the received level of carrier "d" shall be -80 dBm.

With "e" and "f" being received 32 dB greater than "d", and "d" being received at -80 dBm, the receiver shall still operate with a BER of less than 0,001 in the D-field.

4.5.7.6.3 Conformance

Conformance tests as defined in clause 5.3.7.6 shall be carried out.

4.5.7.7 Spurious emissions when the PP has no allocated transmit channel

4.5.7.7.1 Definition

The maximum power level of any spurious emission when the PP has not been allocated a transmit channel.

4.5.7.7.2 Limits

4.5.7.7.2.1 Out of band

The power level of any spurious emissions when the radio end point has no allocated transmit channel shall not exceed 2 nW between 30 MHz and 1 GHz. Between 1 GHz and 12,75 GHz the power level shall not exceed 20 nW.

The power shall be measured using a peak hold technique with a 100 kHz measurement bandwidth below or at 1 GHz and with a 1 MHz measurement bandwidth above 1 GHz.

4.5.7.7.2.2 In the DECT band

The power level of any spurious emissions within the DECT band shall not exceed 2 nW measured in a 1 MHz bandwidth. The following exceptions are allowed:

- a) in one 1 MHz band, the maximum allowable Effective Radiated Power (ERP) shall be less than 20 nW;
- b) in up to two bands of 30 kHz, the maximum ERP shall be less than 250 nW.

4.5.7.7.3 Conformance

Conformance tests as defined in clause 5.3.7.7 shall be carried out.

4.5.8 Channel access

4.5.8.1 Channel selection

The requirements given in ETSI EN 300 175-3 [2], clauses 11.4 and 11.6 shall apply. The tests methods described in clauses 5.3.8.1 to 5.3.8.3 shall be carried out.

For DECT Ultra Low Energy devices the requirements given in clause 4.5.8.5 shall apply.

If the EUT also supports "no-emission" mode, in this mode the quick wakeup-selection according to ETSI EN 300 175-3 [2], clauses 9.4.3 and 9.4.4 shall be confirmed.

4.5.8.2 Channel confirmation

4.5.8.2.1 For the PT

All requirements in the present clause shall be tested against clauses 5.3.8.1 to 5.3.8.3:

- the first PT transmission on the newly selected channel shall be made in accordance with the scan sequence of the addressed RFP;
- to continue transmitting on the newly selected physical channel the PT shall receive an indication that the FT is receiving the PT transmissions within 2 frames of the first PT transmission. For the "no-emission" mode wakeup requests, longer unconfirmed transmission intervals of up to N211 frames (see ETSI EN 300 175-3 [2], clause A.2) are allowed. See also ETSI EN 300 175-3 [2], clause 9.4.4.

4.5.8.2.2 For the FT

All requirements in the present clause shall be tested against clauses 5.3.8.1 to 5.3.8.3:

- the RFP shall not transmit on more than 2 physical channels for which complementary physical channels do not exist; for the "no-emission" mode wakeup requests, longer unconfirmed transmission intervals of up to N210 frames (see ETSI EN 300 175-3 [2], clause A.2) are allowed. See also ETSI EN 300 175-3 [2], clause 9.4.3. For this time span the RFP may transmit on more than 2 physical channels for which complementary physical channels do not exist. The total time used for the above mentioned physical channels shall not exceed 2 ms per frame;

- temporarily more than 2 dummy bearers may exist when an RFP has double dummies and dummy bearer hopping is enabled as defined in ETSI EN 300 175-3 [2];

NOTE: A complementary physical channel is a physical channel between the same two radio endpoints which occurs 5 ms before or after the physical channel to which it is complementary.

- the first transmission of an FT, which uses fast connection setup to address a specific PT, shall be made in accordance with the scan sequence of the addressed PT receiver;
- to continue transmitting on the selected physical channel the FT shall receive an indication that the PT is receiving the FT transmissions within 2 frames of the first FT transmission.

4.5.8.3 Channel release

All requirements in the present clause shall be tested against clauses 5.3.8.1 to 5.3.8.4:

- a radio end point shall cease transmission of a bearer on a physical channel and release the bearer if it has not received the correct RFPI, with a correct CRC, on that bearer in the last 10 seconds;
- a radio end point which transmits on both the physical channel and complementary physical channel shall cease to transmit on the channels if either:
 - the receiving endpoint indicates to the transmitting endpoint that transmission shall cease on both these physical channels; or
 - the transmitting FT or PT is no longer attempting to receive at least one physical channel from the FT or PT to which it is transmitting.

4.5.8.4 General

All requirements in the present clause shall be tested against clause 5.3.8:

- multibearer connections shall only exist in full slot, long slot, double slot and half slot transmission mode;
- the EUT is capable of communicating on all 10 DECT RF channels, $c < 10$.

4.5.8.5 Channel selection and confirmation for DECT ULE

4.5.8.5.1 General

For DECT Ultra Low Energy devices, the EUT shall follow all obligatory conditions given by ETSI EN 300 175-3 [2], clause 11.12. Conformance shall be assessed using the tests described in clauses 5.3.8.1 to 5.3.8.3.

4.5.8.5.2 For the PT

All requirements in the present clause shall be tested against clauses 5.3.8.1 to 5.3.8.3 to ensure conformance, unless otherwise stated:

- the PT implements the PT related requirements of the overall architecture of ULE channel selection processes described in ETSI EN 300 175-3 [2], clause 11.12.2;
- the PT implements the Process M1 (PP side channel selection process) as described in ETSI EN 300 175-3 [2], clause 11.12.5 and the Setup attempt and evaluation of responses described in ETSI EN 300 175-3 [2], clause 11.12.6;
- the PT implements the Process M2 (collision handling/collision avoidance process) as described in ETSI EN 300 175-3 [2], clause 11.12.7.

4.5.8.5.3 For the FT

All requirements in the present clause shall be tested against clauses 5.3.8.1 to 5.3.8.2 to ensure conformance, unless otherwise stated:

- the RFP implements the FT related requirements of the overall architecture of ULE channel selection processes described in ETSI EN 300 175-3 [2], clause 11.12.2;
- the RFP implements a RFP side pre-selection process according to ETSI EN 300 175-3 [2], clause 11.12.3;
- the RFP implements the Broadcasts mechanism described in ETSI EN 300 175-3 [2], clause 11.12.4.

4.5.9 WRS testing

4.5.9.0 General requirements

Clause 4.5.9 shall apply if the EUT is a WRS.

The WRS shall be tested as a stand alone PP and shall comply with all relevant PP test cases in the present document. In addition the WRS shall be tested as an RFP as regards the carrier frequency demands of clause 4.5.1 and reference timer accuracy demands of clause 4.5.2 of the present document.

The WRS EUT shall meet the requirements described in clauses 4.5.9.1 to 4.5.9.4 of the present document.

A WRS requires to be synchronized to a dummy bearer to derive its reference timer for PT and FT transmissions.

4.5.9.1 Testing as a PP

The WRS shall operate as a PP in Test Standby Mode (TSM), as a stand alone module.

In this mode it shall be tested as a normal PP with the exception that it shall be tested for the RFP class E2 if it is intended for outdoor use, and that test case 19 is not applicable. See figure 2.

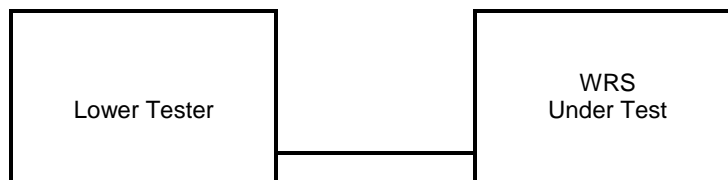

Figure 2: WRS testing as a PP

4.5.9.2 Testing as an RFP

A dummy bearer shall be generated by the Lower Tester or (if that is not possible) by an RFP supplied by the manufacturer and conforming to the present document. The WRS EUT shall be synchronized to the dummy bearer and shall operate as an RFP in Test Standby Mode (TSM). The dummy bearer may change bearer during the test.

The EUT shall comply with the FT demands of the present document on reference timer accuracy, frequency accuracy, equipment identity and efficient use of the radio spectrum. See figure 3.

NOTE: The power combiner is not needed if the PP and RFP functions have different antenna connectors.

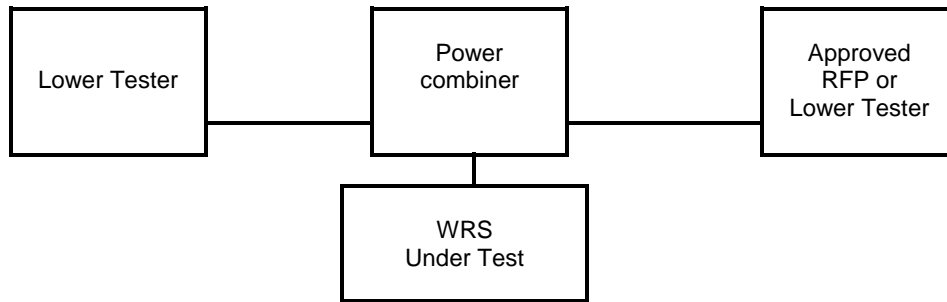

Figure 3: WRS testing as an RFP

4.5.9.3 Additional requirements

- a) The EUT shall provide a mechanism, to control the number of multihops:
 - The WRS that is locked to an FT shall decrease the value HOPS (when > 0) of the corresponding WRS type CRFP or REP respectively; see clause 5 and see ETSI EN 300 175-3 [2], clause 7.2.3.5.2.1 for the transmission of the extended fixed part capability information.
- b) The EUT of CRFP type shall apply the following frame multiplexing structure:
 - Figure 4 shows the typical frame multiplexing structure for a CRFP that supports full slots with I_N _minimum_delay.

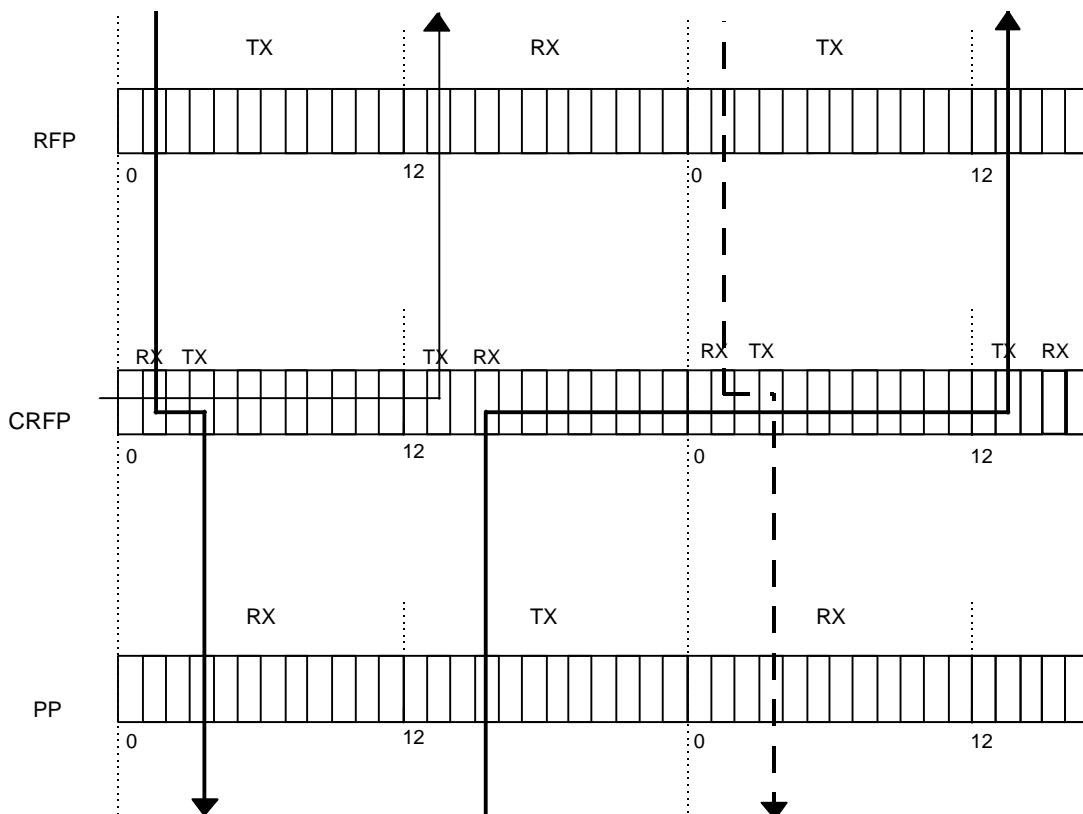

Figure 4: Typical frame multiplexing structure of the CRFP

- Use of one hop via a CRFP will cause an additional delay of 1 frame, no matter what timeslots are used.
- The frame multiplexing structure supports a combination of both links with PTs and FTs. In this dual frame multiplexing structure the CRFP may transmit or receive during any slot of a frame. A duplex bearer to either the PT or FT is still supported by a combination of a CRFP Receive (RX) and Transmit (TX) slot separated by one half frame.

- The CRFP shall support the frame multiplexing structure defined as:
 - CRFP-PT frames and CRFP-FT frames are synchronized to the FT frames;
 - CRFP-PT and CRFP-FT bearer control complies at least with ETSI EN 300 175-3 [2] (e.g. Duplex bearers are separated by one half frame);
 - relayed logical channels are buffered to support MAC multiplexing rules of CRFP-PT and CRFP-FT;
 - available slots of the CRFP are marked to be either Receive (RX) or Transmit (TX) slots. A slot shall be regarded as TX slot only when it is actually used for transmission.

NOTE 1: During the first half frame (e.g. Slot 0 to 11) all RX slots listen to FT transmissions and all TX slots transmit to PTs. During the second half frame all RX slots listen to PTs and all TX slots should transmit to FT.

- RX and TX slots of one relayed bearer belong to the same half frame.

NOTE 2: In idle mode the CRFP listens to an FT during all frames, transmits at least one dummy bearer (see ETSI EN 300 175-3 [2]) to PTs and performs receiver scanning on all other slots. Idle receiver scanning is done in accordance with PT and FT idle receiver scan procedures.

c) The EUT of REP type shall apply the following frame multiplexing structure:

- REP can switch from transmit to receive mode on a time slot base. REP, once locked to a suitable FT (other WRS), is listening for bearer set up attempts on the idle time slots (i.e. slots where REP does not transmit nor receive) of the second half frame while, on the idle time slots of the first half frame, it is scanning for suitable channels and listening for suitable FTs (other WRSs) to get synchronized to. REP shall scan the radio environment in the second half frame synchronously with the locked FT (other WRS).
- REP relays the information received from one radio termination to another radio termination, combining Physical and MAC layer functionalities both of a PT and of an FT, with some improvements when interfacing the FT (another WRS). The relay of the information between the two radio terminations is completed within the half frame time interval.
- Figure 5 describes an example of frame structure and slot allocation within REP, RFP and PP when relaying one duplex bearer connection through a single hop; figure 5a describes the frame multiplexing structure when relaying one duplex bearer connection through two hops.

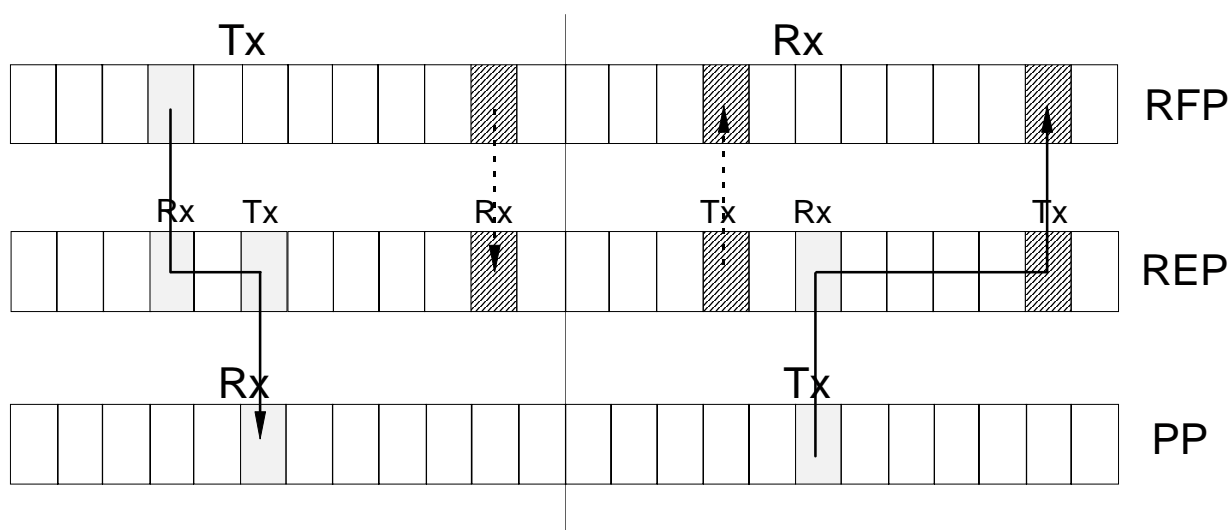

Figure 5: Frame multiplexing structure when relaying one duplex bearer connection through a single hop

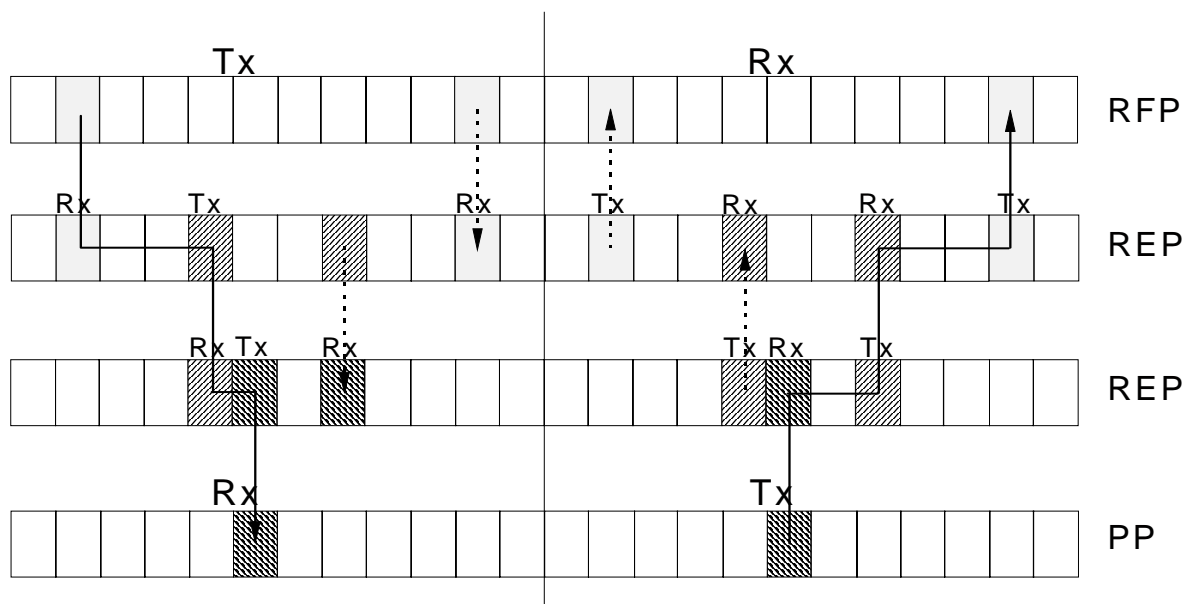

Figure 5a: Frame multiplexing structure when relaying one duplex bearer connection through two hops

- In figure 6 an example of two single duplex bearer connections, REP relayed with an interlacing procedure (see ETSI EN 300 700 [5], clause 6.4.1.1.3) is presented; PP1 and PP2 connections share on REP the slot pair (i.e. the duplex bearer) marked with "S".

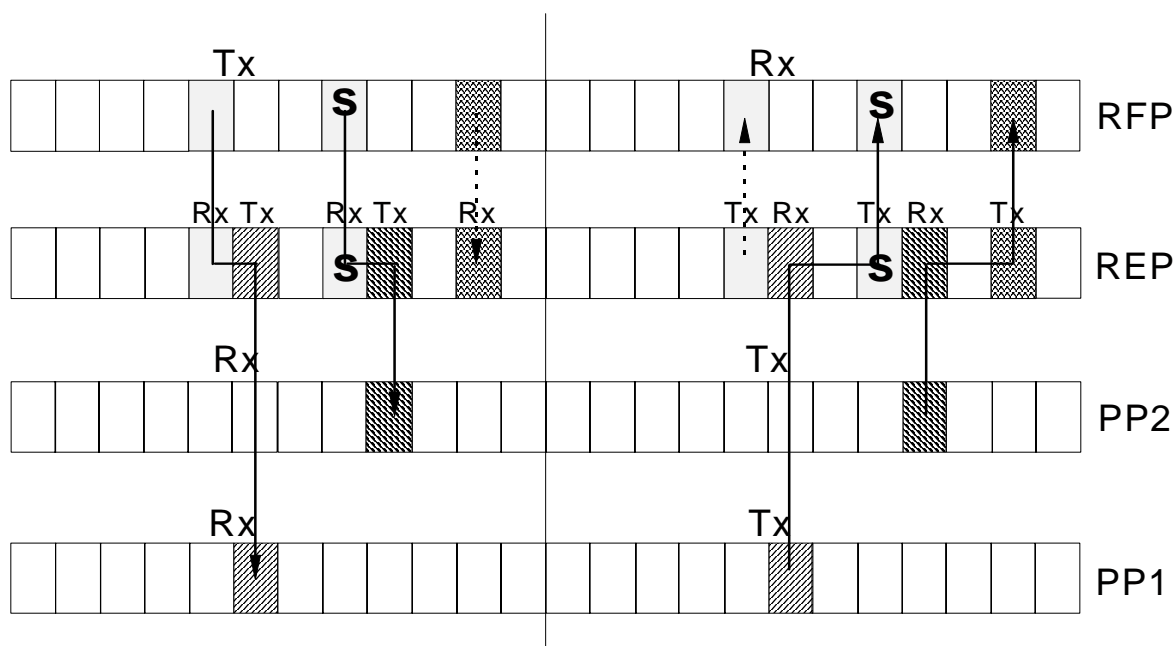

Figure 6: Two single duplex bearer connections, REP relayed with interlacing

- d) The REP EUT shall conform to the requirements for channel selection of double duplex bearers:
- Once in one of the states, i.e. Active_Idle or in Active_Traffic or in Active_Locked, REP may start transmission on a physical channel according to ETSI EN 300 175-3 [2], clause 11.4 with the following additions:
 - double duplex bearers:

- The relay of a duplex or of a double duplex bearer requires, at the REP_PT air interface, the setup of a double duplex bearer. Said $((y ; y + 12) ; f_y)$ and $((z ; z + 12) ; f_z)$ the two time slot pairs of the double duplex bearer to be setup and respectively $((x ; x + 12) ; f_x)$ or $((x_1 ; x_1 + 12) ; f_{x_1})$ and $((x_2 ; x_2 + 12) ; f_{x_2})$ the time slot pair or the two time slot pairs of the associated duplex bearer or double duplex bearer to be relayed, the following further restriction has to be respected:

$$0 \leq Y < X \text{ (where } X = \min (X_1; X_2)); \text{ and}$$

$$X < Z \leq 11 \text{ (where } X = \max (X_1; X_2));$$

- double simplex bearer:

- The relay of a double simplex bearer requires, at the REP_PT (REP_FT) air interface, the setup of another double simplex bearer.
- Said $(x ; x + 12)$ the time slot pair of the double simplex bearer to be setup and $(y ; y + 12)$ the time slot pair of the double simplex bearer to be relayed, the following further restriction has to be respected:

$$X > Y.$$

4.5.9.4 Conformance

Conformance tests as defined in clause 5.3.9 shall be carried out.

4.5.10 Requirements for PPs with direct PP to PP communication mode

4.5.10.1 General requirements

Clause 4.5.10 shall apply if the EUT implements PP to PP communication.

Most PPs will be able to operate also in the normal non-direct communication mode. In this case the direct mode will be temporary, and all PPs in a group of PPs intended to communicate in direct communication mode have to be switched into this mode (manually or by other means), since a PP in normal (non-direct communication) mode can only receive paging information from the system to which it is locked. For further description see annex G of ETSI EN 300 175-3 [2].

PPs or CTAs in direct communication mode shall meet the PP requirements for normal non-direct communication with the amendments defined in the ETSI EN 300 175-3 [2], clauses G.2.1 and G.2.2.

4.5.10.2 Conformance

Conformance tests as defined in clause 5.3.10 shall be carried out.

4.5.11 Direct Communication

4.5.11.0 General requirements

Clause 4.5.11 shall apply if the EUT implements Direct communication.

PPs and CTAs with direct PP to PP communications option (HyPs), shall be tested as a stand alone PP and shall comply with all relevant PP test cases in the present document. In addition the HyPs shall be tested as an RFP as regards the carrier frequency demands of clause 4.5.1 and reference timer accuracy demands of clause 4.5.2.

The HyP EUT shall meet the requirements as described below.

A HyP requires to be synchronized to a bearer to derive its reference timer for PT and FT transmissions.

4.5.11.1 Testing as a PP

The EUT shall operate as a PP in Test Standby Mode (TSM), as a stand alone module.

In this mode it shall be tested as a normal PP. See figure 7.

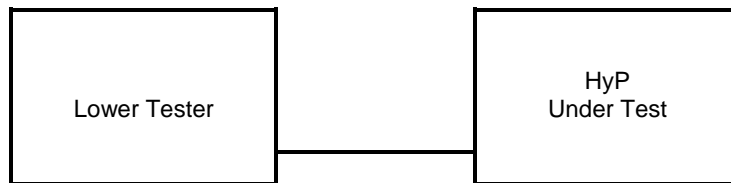

Figure 7: HyP testing as a PP

4.5.11.2 Testing as an RFP

A dummy bearer shall be generated by the Lower Tester or (if that is not possible) by an RFP supplied by the manufacturer and conforms to the present document. The EUT shall be synchronized to the dummy bearer and shall operate as an RFP in Test Standby Mode (TSM). The dummy bearer may change bearer during the test.

The EUT shall comply with the FT demands of the present document on reference timer accuracy, frequency accuracy, equipment identity and efficient use of the radio spectrum. See figure 8.

NOTE: The power combiner is not needed if the PP and RFP functions have different antenna connectors.

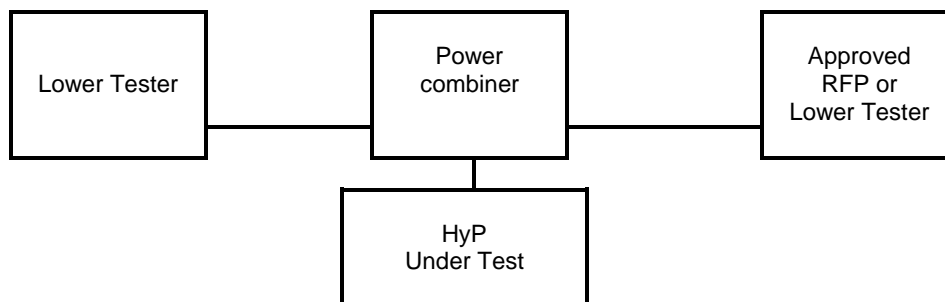

Figure 8: HyP testing as an RFP

4.5.11.3 Conformance

Conformance tests as defined in clause 5.3.11 shall be carried out.

4.5.12 Higher level modulation options

4.5.12.0 Requirements

The 4-level modulation shall be $\pi/4$ -DQPSK, the 8-level modulation $\pi/8$ -D8PSK, the 16-level modulation 16 QAM and the 64-level modulation 64 QAM (see ETSI EN 300 175-2 [1], annex D). It is only allowed to use 4-level or higher level modulation in the B + Z or the A + B + Z fields, see ETSI EN 300 175-2 [1], clause 4.8 and ETSI EN 300 175-3 [2], clause 6.2.1.1, whereby the S + A or the S field respectively shall use the $\pi/2$ -DBPSK 2-level modulation as defined in ETSI EN 300 175-2 [1], annex D. The different configurations, 1a to 6, for allowed combinations of modulation schemes are defined in table 10.

Table 10: Configurations of allowed combinations of modulation types in the S-, A and (B+Z)-fields

Configuration	S-field	A-field	B+X+Z-field when E/U mux is in U mode	B+X+Z-field when E/U mux is in E or E+U modes (see note)
1a	GFSK	GFSK	GFSK	GFSK
1b	$\pi/2$ -DBPSK	$\pi/2$ -DBPSK	$\pi/2$ -DBPSK	$\pi/2$ -DBPSK
2	$\pi/2$ -DBPSK	$\pi/2$ -DBPSK	$\pi/4$ -DQPSK	$\pi/4$ -DQPSK
2b	$\pi/2$ -DBPSK	$\pi/2$ -DBPSK	$\pi/4$ -DQPSK	$\pi/2$ -DBPSK
3	$\pi/2$ -DBPSK	$\pi/2$ -DBPSK	$\pi/8$ -D8PSK	$\pi/8$ -D8PSK
3b	$\pi/2$ -DBPSK	$\pi/2$ -DBPSK	$\pi/8$ -D8PSK	$\pi/4$ -DQPSK
4a	$\pi/2$ -DBPSK	$\pi/4$ -DQPSK	$\pi/4$ -DQPSK	$\pi/4$ -DQPSK
4b	$\pi/2$ -DBPSK	$\pi/8$ -D8PSK	$\pi/8$ -D8PSK	$\pi/8$ -D8PSK
5	$\pi/2$ -DBPSK	$\pi/2$ -DBPSK	16-QAM	16-QAM
6	$\pi/2$ -DBPSK	$\pi/2$ -DBPSK	64-QAM	64-QAM

NOTE: Applies when the E/U multiplexer is in any control mode (see ETSI EN 300 175-3 [2], clauses 6.2.2.2 and 6.2.2.3).

Configuration 1a is the basic DECT modulation scheme for which all tests in the present document are defined. Equipment that is capable of operating in any of the configurations 2 - 6 shall also be able to operate in configuration 1 (1a or 1b).

Such equipment shall in configuration 1a conform to all requirements of the present document that apply for equipment using the basic 1a configuration.

Such equipment that does not support configuration 1a, shall in configuration 1b conform to all requirements (verdict criteria) of the present document that apply for equipment using the basic 1a configuration, with the exception for clause 4.5.5 "RF carrier modulation" and clauses 4.5.3.1.6 "Minimum power" and 4.5.3.1.7 "Maximum power".

Additionally, if the equipment includes a radio transmitter capable of 4-level and/or higher level modulation, the requirements of clauses 4.5.4 and 4.5.6 shall apply for the transmissions using the 4-level and/or higher level modulation in the B + Z or A + B + Z fields.

All modulation modes and power templates shall conform to the standard ETSI EN 300 175-2 [1], annex D.

The manufacturer shall provide declaration of the high-level modulation modes that are supported by the equipment Under Test (see clause 4.3). Only modes declared as supported shall be subject to testing.

4.5.12.1 Conformance

Conformance shall be proven by repeating the tests specified in clauses 5.3.1, 5.3.2, 5.3.3, 5.3.4, 5.3.5, 5.3.6, 5.3.7 and 5.3.8 (for Equipment that includes a radio transmitter) with the claimed high level modulation modes.

In addition to that, the conformance tests as defined in clause 5.3.12 shall be carried out.

5 Testing for compliance with technical requirements

5.1 General test requirements

5.1.1 Test philosophy

All the tests in the present document are based upon a common philosophy. This philosophy assumes that test equipment is capable of emulating a PT or FT that conforms to the DECT CI specification ETSI EN 300 175 parts 2 [1] to 3 [2] and ETSI EN 300 175 parts 5 [3] to 6 [4]. Consequently, each test setup consists of the test equipment being connected to the EUT, either by a radio link or via an antenna connector. Figures 9 and 10 show the possible test configurations.

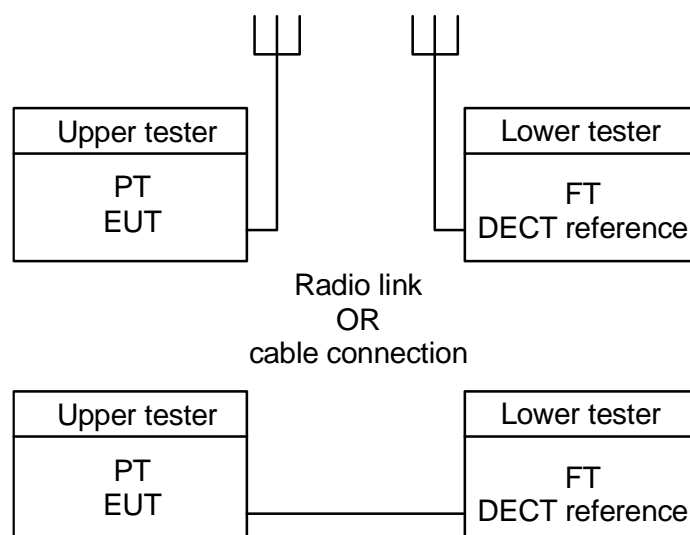

Figure 9: The EUT is a PT

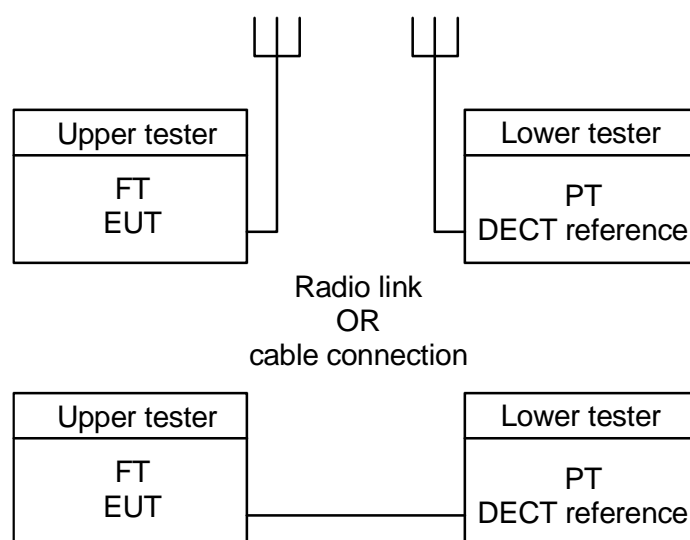

Figure 10: The EUT is an FT

Figures 9 and 10 also show that, if available, the EUT can sometimes be connected to the LT by an antenna connector. This is normally preferred in order to minimize the measurement uncertainties, however, in some test cases this is not permitted and is stated as such in each test case.

The LT shall consist of the general test equipment with the functionality as described in clause 5.1.9. It shall also include an RF interface which can emulate a DECT PT, or FT. The emulated DECT PT and FT (see clause 5.1.11) is an implementation of the DECT CI specification including all the mandatory services and facilities and some provision optional, process mandatory elements as well.

The UT is contained within the EUT and operates in response to test commands which are sent by the LT over the air interface. This enables the LT to place the EUT in a variety of test modes. These are described in clause 5.1.10.

5.1.2 Test site

5.1.2.1 Open air test site

5.1.2.1.1 Description

The term "open air" shall be understood from an electromagnetic point of view. Such a test site may be really in open air or, alternatively, with walls and ceiling transparent to the radio waves at the frequencies considered.

An open-air test site may be used to perform the measurements using the radiated measurement methods described in annex B in the frequency range over which the site may be calibrated. Absolute or relative measurements may be performed on transmitters or receivers; absolute measurements require a calibration of the test site.

The distance between the equipment under test or substitution antenna and the test antenna shall be in accordance with current testing practice. Measuring distances of 3 m, 5 m, 10 m and 30 m are in common use in European test laboratories. A measurement distance of 1 m may be used for frequencies above 1 GHz if the dimensions of the test antenna is less than $[1 \text{ m} \times \lambda/2]^{1/2}$.

The test site shall be large enough to allow the erection of a measuring or transmitting antenna at a distance of $\lambda/2$ at the frequency of measurement or 3 m (1 m above 1 GHz), whichever is the greater. The height of the equipment or of the substitution antenna shall be 1,5 m; the height of the test antenna (transmit or receive) shall be variable between 1 and 4 m. The support for the equipment or substitution antenna shall be capable of 360° rotation and be made of a non-conductive material. The overall size of the open-air test site shall be approximately $2 \times D$ m by $3 \times D$ m, where D is the measuring distance.

To eliminate errors caused by reflection coefficient variation from one measurement geometry to another, the standard ground plane should be substantially flat and horizontal; it should be made from a highly conductive metal. It shall be large enough (at least 5 m in diameter) to provide consistent ground reflections. The support for the equipment or substitution antenna shall be positioned in the middle of the ground plane. Sufficient precautions shall be taken to ensure that reflections from extraneous objects adjacent to the site do not degrade the measurement results, in particular:

- no extraneous conducting objects having any dimension in excess of a quarter wavelength of the highest frequency tested shall be in the immediate vicinity of the site;
- all cables shall be as short as possible; as much of the cables as possible shall be on the ground plane or preferably below and the low impedance cables shall be screened.

5.1.2.1.2 Calibration

The calibration allows the creation, in a given place, of a known signal level by the means of a signal generator connected to a substitution antenna. The calibration is valid only at a given frequency for a given polarization and for the exact position of the test antenna.

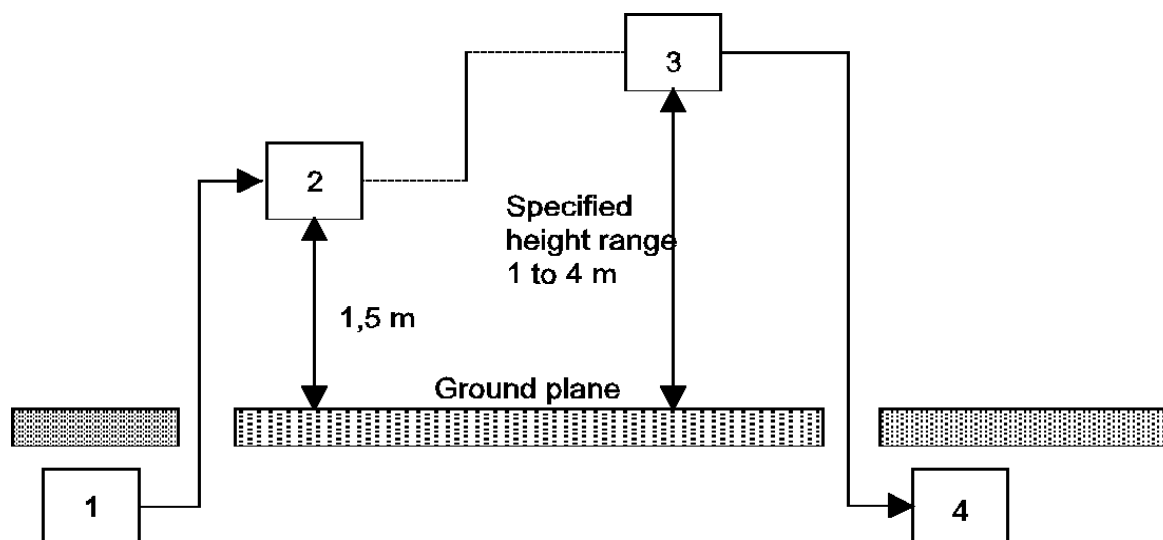

NOTE: 1: Signal generator;
2: Substitution antenna;
3: Test antenna;
4: Selective voltmeter.

Figure 11: Measuring arrangement for calibration

All the equipment shall be arranged as shown in figure 11 and adjusted to the frequency at which the calibration is to be performed.

The test antenna and the substitution antenna shall have the same polarization.

The test antenna connected to the selective voltmeter constitutes a calibrated signal level meter:

- the signal generator level shall be adjusted to produce the required signal level as measured on the selective voltmeter;
- the test antenna shall be raised or lowered through the specified range until the maximum signal level is detected on the selective voltmeter;
- the signal generator level shall be readjusted to produce the required signal level as measured on the selective voltmeter. Thus a relationship has been established between the signal generator level and the signal level.

5.1.2.2 Anechoic chamber

5.1.2.2.1 General

An anechoic chamber is a well shielded chamber covered inside with RF absorbing material and simulating a free space environment. It is an alternative site on which to perform the measurements using the radiated measurement methods described in annex B in the frequency range over which it may be calibrated. Absolute or relative measurements may be performed on transmitters or on receivers. Absolute measurements require a calibration of the anechoic chamber. The test antenna, equipment under test and substitution antenna are used in a way similar to that at the open air test site, but are all located at the same fixed height above the floor.

5.1.2.2.2 Description

An anechoic chamber should meet the requirements for shielding loss and wall return loss as shown in figure 12. Figure 13 shows an example of the construction of an anechoic chamber having a base area of 5 m by 10 m and a height of 5 m.

The ceiling and walls are coated with pyramidal absorbers approximately 1 m high. The base is covered with special absorbers which form the floor. The available internal dimensions of the chamber are 3 m × 8 m × 3 m, so that a maximum measuring distance of 5 m in the middle axis of this chamber is available. The floor absorbers reject floor reflections so that the antenna height need not be changed. Anechoic chambers of other dimensions may be used.

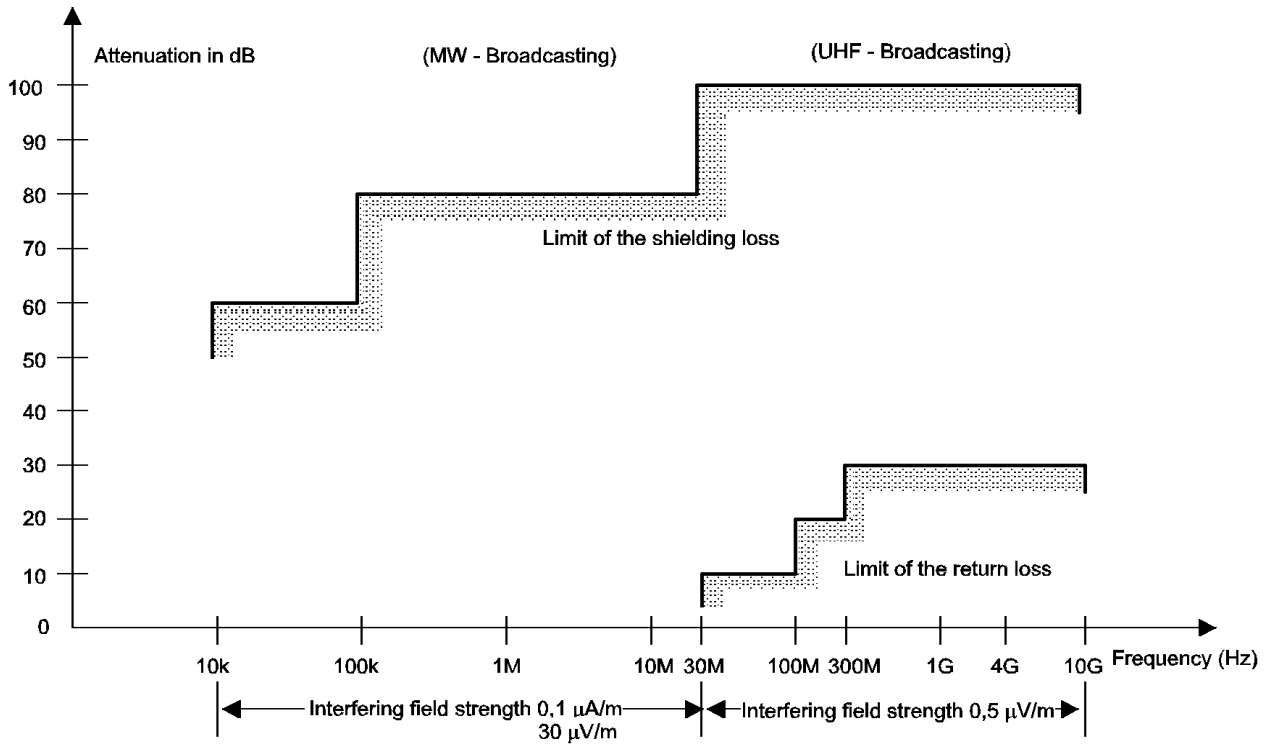

Figure 12: Shielding and wall return loss

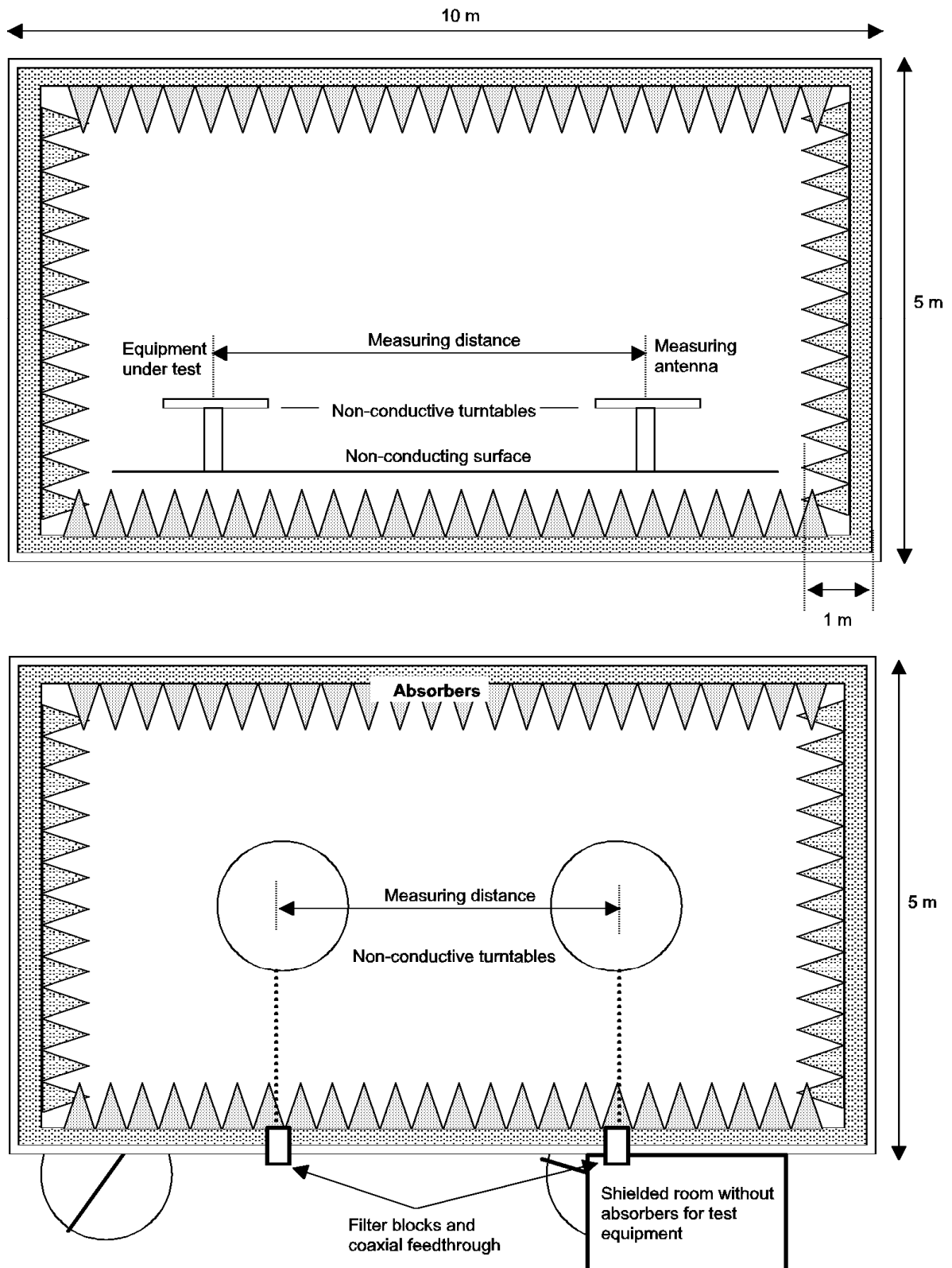

Figure 13: Construction example

5.1.2.2.3 Influence of parasitic reflections

For free-space propagation in the far field the relationship of the signal level X and the distance R is given by:

$$X = X_0 \times (R_0 / R) \quad (1)$$

where X_0 is the reference signal level and R_0 is the reference distance. This relationship allows relative measurements to be made as all constants are eliminated within the ratio and neither cable attenuation nor antenna mismatch or antenna dimensions are of importance.

If the logarithm of above equation (1) is used, the deviation from the ideal curve can be easily seen because the ideal correlation of signal level and distance appears as a straight line. The deviations occurring in practice are then clearly visible. This indirect method shows quickly and easily any disturbances due to reflections and is far less difficult than the direct measurement of reflection attenuation.

With an anechoic chamber of the dimensions given above at low frequencies below 100 MHz there are no far field conditions, but the wall reflections are stronger, so that careful calibration is necessary. In the medium frequency range from 100 MHz to 1 GHz the dependence of the signal level to the distance meets the expectations very well. Above 1 GHz, because more reflections will occur, the dependence of the signal level to the distance will not correlate so closely.

5.1.2.2.4 Calibration and mode of use

The calibration and mode of use is the same as for an open air test site, the only difference being that the test antenna does not need to be raised and lowered whilst searching for a maximum, which simplifies the method of measurement.

5.1.2.3 Stripline coupler

5.1.2.3.0 General

The stripline arrangement is a RF coupling device for coupling the integral antenna of an equipment to a 50 Ω radio frequency terminal. This allows the radiated measurements described in clause 5 to be performed without an open air test site but in a restricted frequency range. Absolute or relative measurements may be performed; absolute measurements require a calibration of the stripline arrangement.

5.1.2.3.1 Description

The stripline is made of three highly conductive sheets forming part of a transmission line which allows the equipment under test to be placed within a known electric field. They shall be sufficiently rigid to support the equipment under test.

An example of stripline characteristics is given below:

- useful frequency range: 0,1 MHz to 4 000 MHz;
- equipment size limits (antenna included):

length:	1 200 mm
width:	1 200 mm
height:	400 mm.

5.1.2.3.2 Calibration

The aim of calibration is to establish at any frequency a relationship between the voltage applied by the signal generator and the signal level at the designated test area inside the stripline.

5.1.2.3.3 Mode of use

The stripline arrangement may be used for all radiated measurements within its calibrated frequency range.

The method of measurement shall be the same as the method using an open air test site with the following change. The stripline arrangement input socket shall be used instead of the test antenna.

5.1.3 Standard position

The standard position in all test sites, except the stripline arrangement, for equipment which is not intended to be worn on a person, including hand-held equipment, shall be on a non-conducting support, height 1,5 m, capable of rotating about a vertical axis through the equipment. The standard position of the equipment shall be the following:

- a) for equipment with an integral antenna, it shall stand so that the axis of the equipment which in its normal use is closest to the vertical shall be vertical;
- b) for equipment with a rigid external antenna, the antenna shall be vertical;
- c) for equipment with a non-rigid external antenna, the antenna shall be extended vertically upwards by a non-conducting support.

In the stripline arrangement the equipment under test or the substitution antenna is placed in the designated test area in the normal operational position, relative to the applied field, on a pedestal made of a low loss and low permittivity dielectric material (dielectric constant less than 2).

5.1.4 Test antenna of the LT

When the test site is used for radiation measurements the test antenna shall be used for reception of the field from both the test sample and the substitution antenna. When the test site is used for the measurement of receiver characteristics the antenna shall be used as a transmitting antenna. This antenna shall be mounted on a support capable of allowing the antenna to be used in either a horizontal or vertical polarization and for the height of its centre above the ground to be varied over the specified range. Preferably test antennas with pronounced directivity should be used. The size of the test antenna along the measurement axis shall not exceed 20 % of the measuring distance.

5.1.5 Substitution antenna

The substitution antenna shall be used to replace the equipment under test. For measurements below 1 GHz the substitution antenna shall be a half wavelength dipole resonant at the frequency under consideration, or a shortened dipole, calibrated to the half wavelength dipole. For measurements between 1 GHz and 4 GHz either a half wavelength dipole or a horn radiator shall be used.

For measurements above 4 GHz a horn radiator shall be used. The centre of this antenna shall coincide with the reference point of the test sample it has replaced. This reference point shall be the volume centre of the sample when its antenna is mounted inside the cabinet, or the point where an outside antenna is connected to the cabinet.

Above 1 GHz the gain of the substitution antenna shall be relative to an isotropic radiator.

Below 1 GHz where a dipole is used as the substitution antenna no gain correction is needed.

The distance between the lower extremity of the dipole and the ground shall be at least 30 cm.

NOTE: The gain of a horn antenna is generally expressed relative to an isotropic radiator.

5.1.6 Test fixture

5.1.6.1 Description

The test fixture is a radio frequency coupling device associated with an integral antenna equipment for coupling the integral antenna to a 50 Ω radio frequency terminal at the working frequencies of the equipment under test. This allows certain measurements to be performed using the conducted measurement methods. Measurements may only be performed at or near frequencies for which the test fixture has been calibrated.

In addition, the test fixture shall provide:

- 1) a connection to an external power supply; and
- 2) interfaces to other relevant inputs and outputs.

The test fixture should be provided by the manufacturer.

The performance characteristics of the test fixture shall be approved by the test laboratory and shall conform to the following basic parameters:

- a) the coupling loss shall not be greater than 20 dB;
- b) a coupling loss variation over the frequency range used in the measurement which does not exceed 2 dB;
- c) circuitry associated with the RF coupling shall contain no active or non-linear devices;
- d) for frequencies of 2 100 MHz and below the Voltage Standing Wave Ratio (VSWR) at the 50 Ω socket shall not be greater than 1,2 and for frequencies above 2 100 MHz the VSWR shall not be greater than 1,5;
- e) the coupling loss shall be independent of the position of the test fixture and be unaffected by the proximity of surrounding objects or people. The coupling loss shall be reproducible when the equipment under test is removed and replaced;
- f) the coupling loss shall remain substantially constant when the environmental conditions are varied.

The characteristics and calibration shall be included in the test report.

5.1.6.2 Calibration of the test fixture for the measurement of transmitter characteristics

The calibration of the test fixture establishes a relationship between the output of the test fixture and the output of the equipment inside the test fixture. See figure 14 for measuring arrangement for calibration.

The calibration is valid only at a given frequency or range of frequencies and for a given polarization of the reference field.

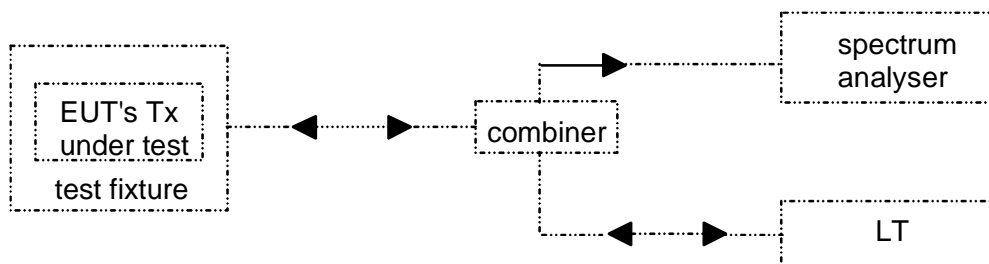

Figure 14: Measuring arrangement for calibration

- a) Using the appropriate method described in clauses 5.3.4.1 and 5.3.4.2 (transmitted power) measure the NTP and note the value of this power and the polarization used.
- b) The transmitter shall be placed in the test fixture which is connected to the spectrum analyser. The measured level in dBm shall be noted.
- c) The calibration for the test fixture is the linear relationship between the measured power in dBm according to clause 5.3.4 (transmitted power) and the measured power in dBm in this calibration setup.

5.1.6.3 Calibration of the test fixture for the measurement of receiver characteristics

The calibration of the test fixture establishes a relationship between the level of the signal connected to the test fixture and the level of the signal applied to the equipment inside the test fixture. See figure 15 for measuring arrangement for calibration.

The calibration is valid only at a given frequency and for a given polarization of the reference field.

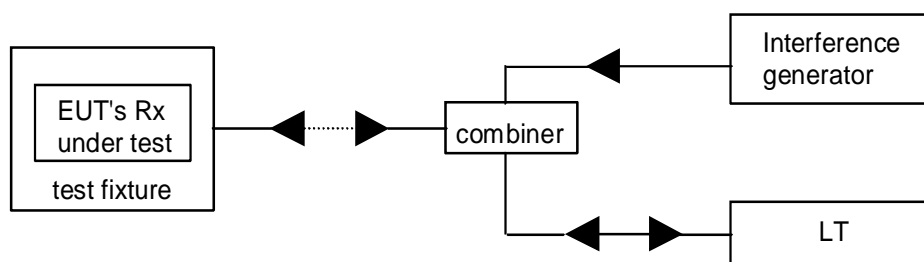

Figure 15: Measuring arrangement for calibration

- a) Measure the sensitivity expressed as signal level for a Bit Error Ratio (BER) of 0,001 or less and note the value of this signal level in dBm and the polarization used.
- b) The receiver shall be placed in the test fixture which is connected to the LT (with BER measuring test facilities). The level of the signal connected to the test fixture producing the same BER measured according to the method used in step a) shall be noted.
- c) The calibration of the test fixture is thus the linear relationship between signal level and the signal generator level in dBm.

5.1.6.4 Mode of use

A test fixture may be used for tests under extreme temperatures and for transmitter and receiver measurements that can be carried out with an uncalibrated test fixture.

If the calibrated test fixture is used as an alternative for the test site then its use, the characteristics and the calibration shall be recorded in the test report.

5.1.7 Equipment with a temporary or internal permanent antenna connector

5.1.7.1 General

The means to access and/or implement the internal permanent or temporary antenna connector shall be stated by the manufacturer with the aid of a diagram.

The fact that use has been made of the internal antenna connection to facilitate measurements shall be recorded in the test report.

All references in the present document to antenna connector, external antenna connector and temporary connectors shall be understood to be identical and to mean an external antenna connector and/or temporary and/or internal permanent connector.

5.1.7.2 Equipment with a temporary antenna connector

The manufacturer, or an authorized representative, may submit one set of equipment with the normal antenna connected, to enable the radiated measurements to be made.

The manufacturer, or an authorized representative, shall attend the test laboratory at conclusion of the radiated measurements, to disconnect the antenna and fit the temporary connector.

The test laboratory staff shall not connect or disconnect any temporary antenna connector.

Alternatively the manufacturer, or an authorized representative, may submit two sets of equipment to the test laboratory, one fitted with a temporary antenna connector with the antenna disconnected and the other with the antenna connected.

Each equipment shall be used for the appropriate tests.

5.1.8 Indoor test site

5.1.8.0 General

An indoor test site may be used instead of an open-air test site or an anechoic room. However, the open-air test site or the anechoic room is preferred. Each test case lists the allowed test sites.

5.1.8.1 Description

An indoor test site is a partially screened site, where the wall located behind the test sample is covered with a radio frequency absorbing material and a corner reflector is used with the test antenna. It may be used when the frequency of the signals being measured is greater than 80 MHz.

The measurement site may be a laboratory room with a minimum area of 6 m by 7 m and at least 2,7 m in height.

Apart from the measuring apparatus and the operator, the room shall be as free as possible from reflecting objects other than the walls, floor and ceiling.

The site arrangement is shown in figure 16 for horizontal polarization.

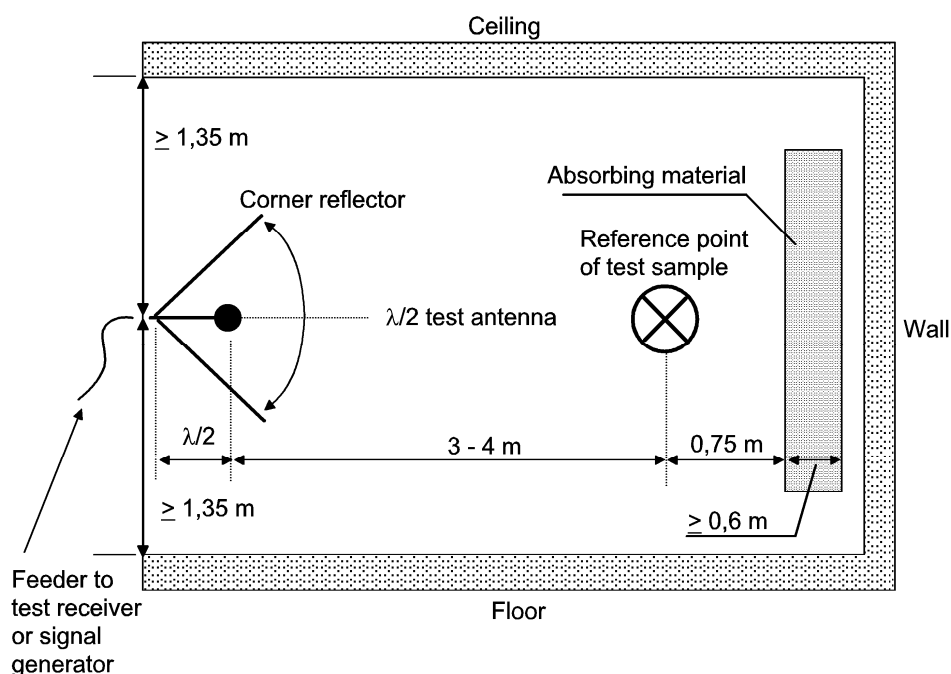

Figure 16: Indoor test site arrangement (shown for horizontal position)

The potential reflections from the wall behind the equipment under test shall be reduced by placing a barrier of absorbent material in front of the wall. The corner reflector around the test antenna shall be used to reduce the effect of reflections from the opposite wall and from the floor and ceiling in the case of horizontally polarized measurements. Similarly, the corner reflector reduces the effects of reflections from the side walls for vertically polarized measurements. For the lower part of the frequency range (below approximately 175 MHz) no corner reflector or absorbent barrier is needed. For practical reasons, the half wavelength antenna in figure 16 may be replaced by an antenna of constant length, provided that this length is between a quarter wavelength and one wavelength at the frequency of measurement and the sensitivity of the measuring system is sufficient. In the same way the distance of half wavelength to the apex may be varied.

5.1.8.2 Test for parasitic reflections

To ensure that errors are not caused by the propagation path approaching the point at which phase cancellation between direct and the remaining reflected signals occurs, the substitution antenna shall be moved through a distance of ± 10 cm in the direction of the test antenna as well as in the two directions perpendicular to this first direction.

If these changes of distance cause a signal change of greater than 2 dB, the test sample should be repositioned until a change of less than 2 dB is obtained.

5.1.8.3 Calibration and mode of use

The calibration and mode of use is the same as for an open air test site, the only difference being that the test antenna does not need to be raised and lowered whilst searching for a maximum, which simplifies the method of measurement.

5.1.9 Lower Tester (LT)

5.1.9.1 Description

The lower tester is a logical grouping that contains a DECT PT, DECT FT, the measurement equipment and the controller of the DECT testing system. The LT has the job of sending testing commands, performing calculations (e.g. signal processing) and interacting with the EUT for the various tests. The LT may implement the Test Support Profile (TSP) described in ETSI EN 300 176-1 [i.11], annex D in order to support the test messages and procedures in a fully standardized manner. This unit is also involved with DECT RF carrier generation, reception, and demodulation. In addition, the LT has wideband RF requirements for emissions and interference testing. See figure 17 for functional contents of the LT.

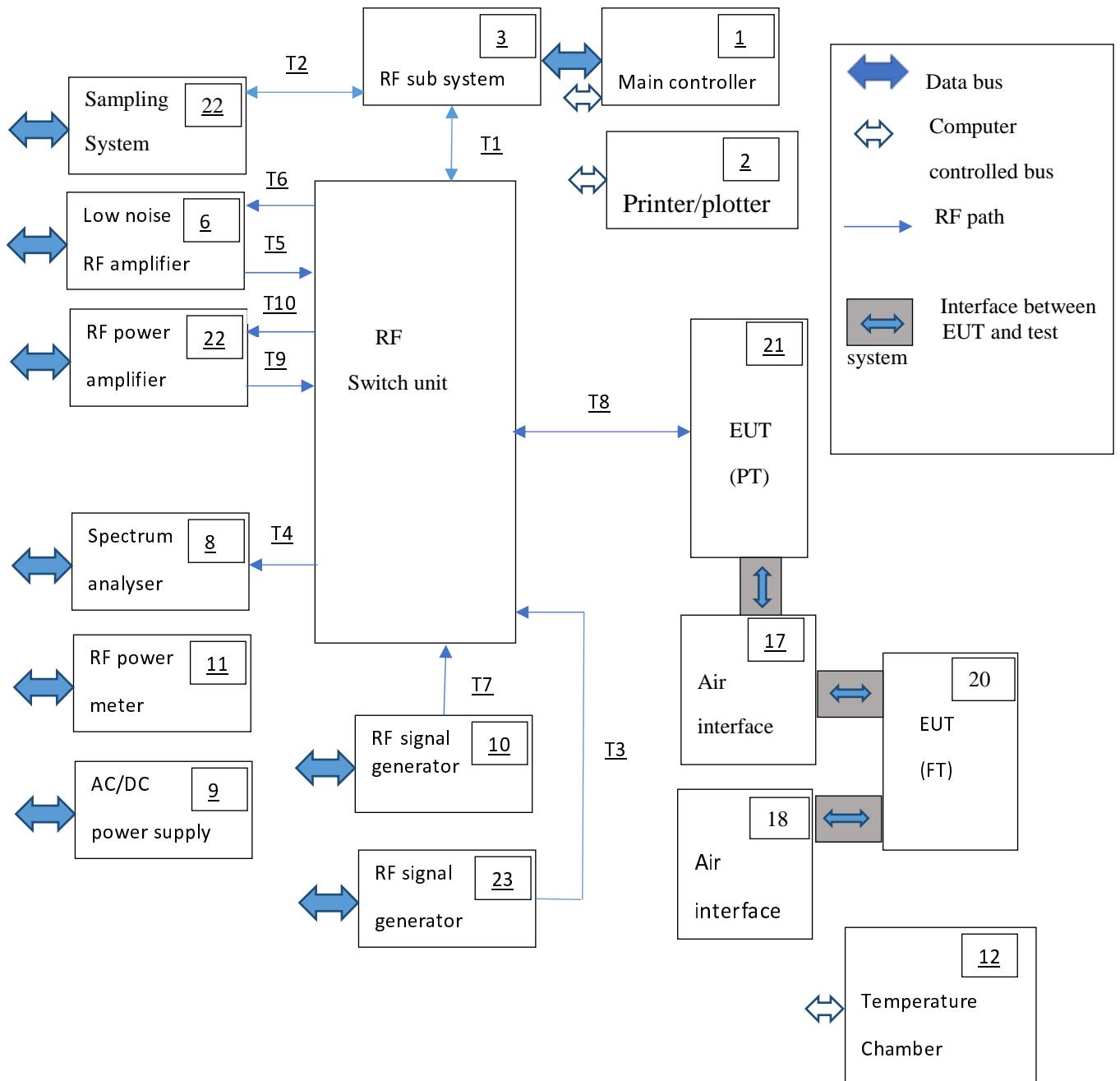

Figure 17: Functional contents of the LT

5.1.9.2 Connections between the EUT and the LT

This is specified in each test case.

5.1.9.3 Functions and abilities

The LT shall include all the functions necessary to perform the tests described in the present document.

These include the ability to:

- generate one actual DECT RF signal;
- generate one Modulated DECT-like carrier;
- generate Continuous Wave (CW) interferer(s);

- sample and store an accurate representation of the EUT's RF signal;
- transmit a variety of test data sequences in the B-field;
- transmit on more than one slot per frame;
- make measurements as described in the present document according to the uncertainties described in clause 5.2;
- emulate a DECT FT, with the possibility to programme all DECT identity codes;
- emulate a DECT PT, with the possibility to programme all DECT identity codes.

5.1.9.4 Signal generation uncertainty

The carrier frequency shall not deviate by more than ± 5 kHz.

5.1.9.5 Modulated DECT-like carrier

This is a RF carrier using Gaussian shaped frequency-shift keying ($BT = 0,5$) modulated with a 1,152 kbit/s pseudo-random sequence with minimum length 2^9-1 . If the signal is bursted, it is required that the burst is synchronized to the DECT test signal generated by the LT.

5.1.9.6 CW interferers

In the case where interferers are applied to the signal under test, as described in clause 4.5.8, the uncertainty of the signal under test should be determined by the overall BER measurement uncertainty of a test case. This is specified in annex F.

5.1.9.7 DECT RF signal

The carrier is defined using the method of clause 4.5.1.1 and it should meet the measurement uncertainties of annex F.

During ramp-up the transmitted RF signal shall be the nominal carrier frequency without modulation. The transmitted signal shall comply with the requirements for the transmission burst as given in clause 4.5.3. The NTP - 1 dB shall not be available more than 2 μ s before start of the first transmitted bit. The transmitter attack time as defined in clause 4.5.3.1.4. shall be less than 5 μ s.

The NTP -1 dB of test equipment that cannot provide an unmodulated carrier shall be available within 1 bit period before start of the first bit transmitted. Moreover the transmitter attack time as defined in clause 4.5.3.1.4 needs to be less than a 2 bit period.

5.1.9.8 Test modulation signals

The test modulating signal is a baseband signal which modulates a carrier and is dependent upon the type of equipment under test and also the measurement to be performed.

Signals for data (bit stream):

- D - M2:** A signal representing a pseudo-random bit sequence of at least 511 bits in accordance with Recommendation ITU-T O.153 [6]. This sequence shall be continuously repeated. This signal shall be used as a wanted signal.

5.1.10 Upper Tester (UT)

5.1.10.1 Description of the UT

For the purpose of testing, an EUT capable of transmitting shall recognize a mandatory set of test commands sent by the LT. The ability to recognize and implement these commands is contained in the UT which is resident in the medium access control layer as described in ETSI EN 300 175-3 [2], and as defined by clause 4.5.9. All DECT equipment shall be capable of recognizing these commands.

An EUT may optionally implement the TSP (as described in ETSI EN 300 176-1 [i.11], annex C). The implementation of the TSP is provision optional, process mandatory.

5.1.10.2 The Test Standby Mode (TSM)

Accessibility to these messages is controlled by some means of mechanical interlocking method or manual switching (e.g. dip-switch, jumper, prom, or key-pad code as designated by the manufacturer) to prevent accidental execution of these messages in a DECT user environment.

When the EUT has been switched into a mode whereby the test messages are accessible, the EUT is said to be in the Test Standby Mode.

5.1.10.3 Test messages

The MAC layer test messages provide the following functions:

- a) instruct the EUT to transmit on a LT-specified physical channel. The test message also determines whether the handover function of the EUT (if so equipped) is disabled and if previous bearers are to be maintained (see ETSI EN 300 175-3 [2], clauses 7.2.5.4.2 and 12.3);
- b) instruct the EUT to perform the loopback function in which a test data pattern transmitted by the LT is replicated in the reply transmission of the EUT. The test data pattern is a bit sequence located in the D-fields of the LT and EUT. The bits of the D-field that are affected by the loopback function depend on the equipment type and are defined in table 11. Equipment capable of transmitting more than one slot type shall use the longest slot type for this test message (see ETSI EN 300 175-3 [2], clauses 7.2.5.4.3 and 12.4).

Table 11: Loopback

Equipment type	Loopback Bits
Transmits only A-field	a ₁₆ to a ₄₇
Transmits half-slots	b ₀ to b ₇₉
Transmits full-slots	b ₀ to b ₃₁₉
Transmits long-slots (variable length slot with j = 640)	b ₀ to b ₆₃₉
Transmits double-slots	b ₀ to b ₇₉₉

- c) defeat antenna diversity and select the specified antenna for operation in those EUTs possessing antenna diversity (see ETSI EN 300 175-3 [2], clauses 7.2.5.4.4 and 12.5);
- d) initiate the bearer handover procedure resident in an EUT in accordance with its intended use as possessing bearer handover capability (see ETSI EN 300 175-3 [2], clauses 7.2.5.4.5 and 12.6);
- e) permit inclusion of proprietary test messages by means of the "escape" code (see ETSI EN 300 175-3 [2], clauses 7.2.5.4.6 and 12.8);
- f) pass test messages (when applicable) to the network layer of the EUT (see ETSI EN 300 175-3 [2], clauses 7.2.5.4.7 and 12.7);
- g) provide for a means to reset the test state of the EUT by means of the "clear test modes" message (see ETSI EN 300 175-3 [2], clauses 7.2.5.4.8 and 12.9).

5.1.10.4 Dummy setting when EUT is an RFP and is in Test Standby Mode (TSM)

If the EUT is an RFP, the dummy bearer shall either be switched off when the traffic bearer is active in Test Standby Mode (TSM), or it is placed on the same RF carrier as the traffic bearer. The manufacturer shall provide a method to do this and shall describe it in the additional information on implementation for testing (see clause 4.3).

Such a method may be controlled either by some means of manual switching (e.g. dip-switch, jumper, prom, or key-pad code as designated by the manufacturer), or by means of a proprietary "escape" code test message.

5.1.11 Description of the lower tester FT and PT

The lower tester FT and PT are systems consisting of the RF equipment, controller(s), software, and other related components necessary to be capable of implementing all the functions defined in the DECT specifications.

5.1.12 General test methods

5.1.12.1 General

Clauses 5.1.12.2, 5.1.12.3 and 5.1.12.4 contain general test methods applicable to a number of tests in the present document.

5.1.12.2 Sampling the RF signal

5.1.12.2.1 Introduction

A number of tests in the present document require the RF signal to be sampled and demodulated. The following text describes the sampling method that should be performed in the LT.

5.1.12.2.2 Sampling method

The equipment under test shall be connected to the LT. This connection shall be direct for an EUT having an antenna connector or via an antenna coupling device for an EUT with an integral antenna and not having means of connecting an external antenna, unless otherwise specified in the present document.

Handover (if available) shall be disabled in the EUT while the sampling takes place (see clause 5.1.10.3 for the appropriate test message reference).

Antenna diversity (if available) shall be disabled in the EUT while the sampling takes place (see clause 5.1.10.3 for the appropriate test message reference).

Using a sampling measurement method, capture a representation of the EUT's transmitted RF signal. The position in a physical packet shall be calculated using the samples from the physical packet, knowing the received bit pattern. These calculated bit positions shall be used as the time reference when making measurements of RF frequency, phase and power.

NOTE: When reference is made to p_0 in the present document, for example, it is intended that its position is calculated using many samples of a physical packet. The frequency, power or phase at this theoretical position of p_0 can then be measured.

5.1.12.3 Determining the reference position

5.1.12.3.0 General

During many tests the EUT is required to be oriented specifically in relation to the test antenna connected to the LT.

This position is called the reference position and is defined in the following clauses.

5.1.12.3.1 Case 1: EUTs that cannot transmit

If the EUT has only an integral antenna then the manufacturer shall inform the test laboratory of the orientation of the integral antenna.

5.1.12.3.2 Case 2: EUTs that can transmit

The EUT shall be placed in a mode whereby it is transmitting.

NOTE: For most tests the EUT will have already been placed in a transmission mode.

The EUT shall be rotated in both horizontal and vertical planes in order to locate the direction of maximum signal level that is detected by the test antenna. This orientation shall be called the reference position.

5.1.12.4 Bit Error Ratio (BER) and Frame Error Ratio (FER) measurements

BER measurements are carried out by comparing data in the loop back field transmitted by the LT with data in the loop back field received from the EUT (which is in loop back mode).

If the EUT does not recognize the sync word of the frame transmitted by the LT and therefore is unable to loop back any data, this frame shall be disregarded from the BER measurement.

Refer to annexes D and E for further information and for the definition of BER and FER.

5.1.13 Test setup

5.1.13.1 General

Test setups have been defined according to ISO/IEC 9646-1 [i.2]. The test cases listed in table 4 have an associated test setup either defined in clause 5.1.13 or described as a specific test within clause 5.3.

The numbers inside the figures shown in clauses 5.1.13.1 to 5.1.13.5 refer to functional blocks inside the LT. These are shown in figure 17.

5.1.13.2 Test setup 1

For the test setup depicted in figure 18, the following test cases apply:

Test Cases: 1, 2, 3, 4, 5, 6, 7, 8, 13 and 14.

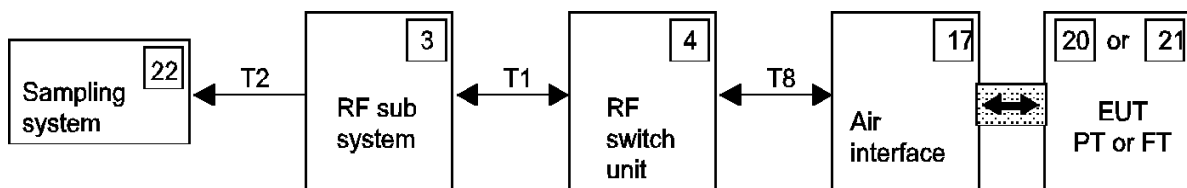

Figure 18: Test setup 1

5.1.13.3 Test setup 2

For the test setup depicted in figure 19, the following test cases apply:

Test Cases: 15, 16 and 17.

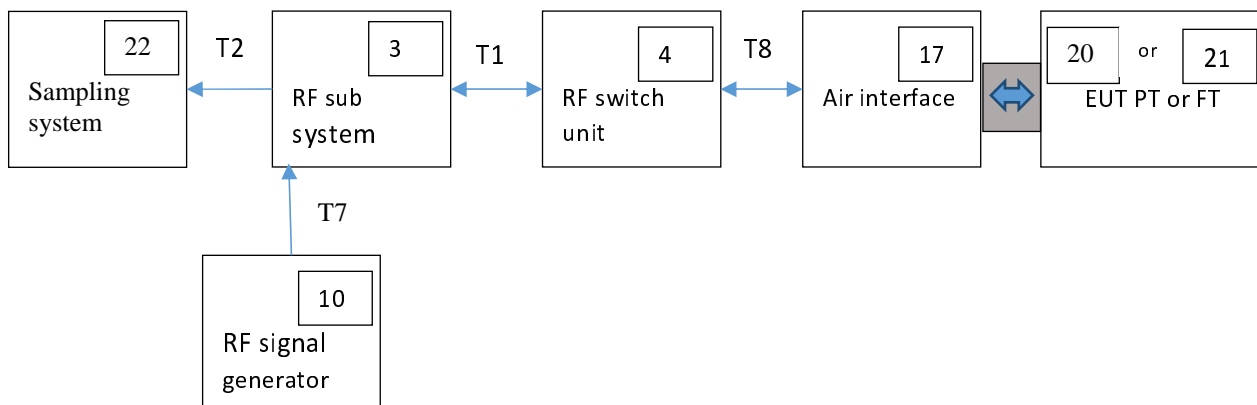

Figure 19: Test setup 2

5.1.13.4 Test setup 3

For the test setup depicted in figure 20, the following test case applies:

Test Case: 18.

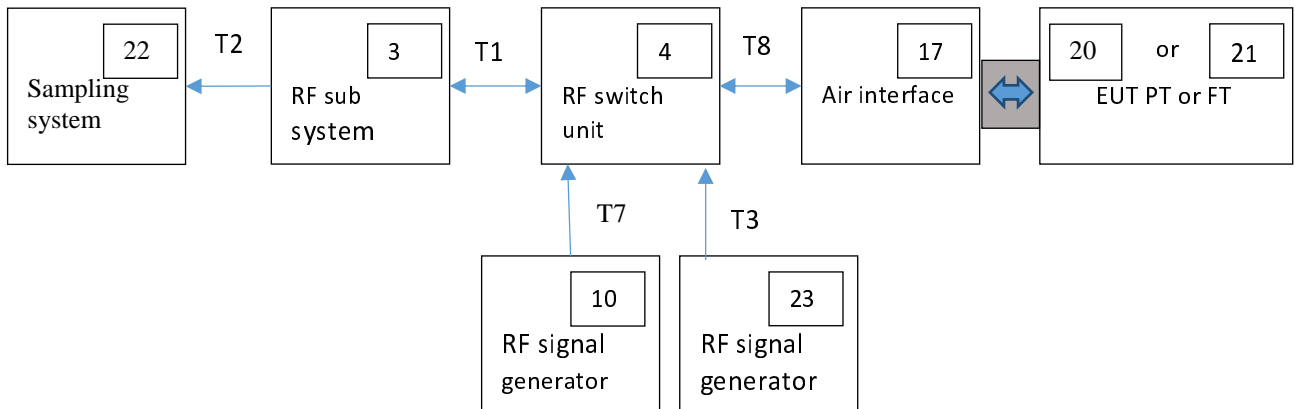

Figure 20: Test setup 3

5.1.13.5 Test setup 4

For the test setup depicted in figure 21, the following test cases apply:

Test Cases: 9, 10, 11, 12 and 19.

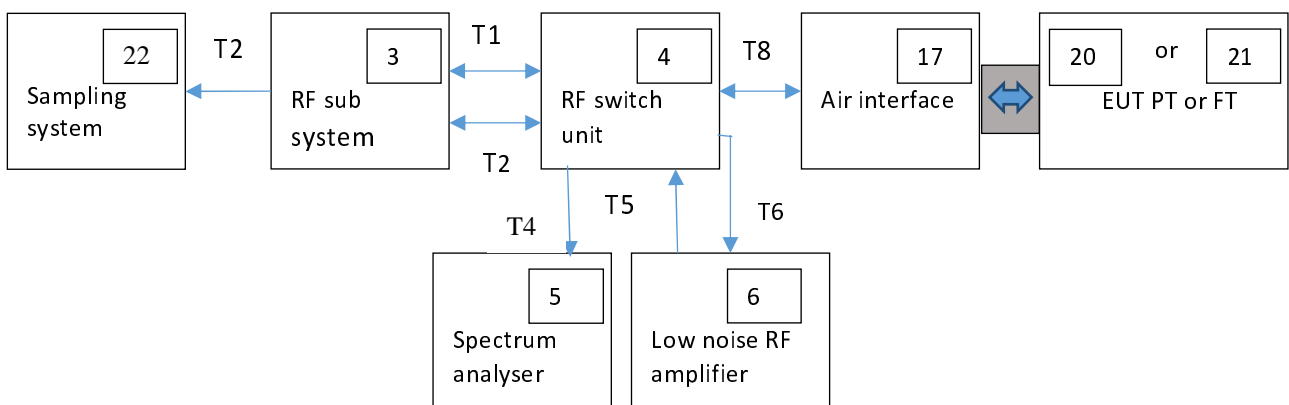

Figure 21: Test setup 4

5.1.14 Test arrangements for intermodulation measurements

5.1.14.1 PT to PT arrangement

In the PT to PT situation, the minimum distance for non-interference operation is specified as being 0,5 m. Figure 22 shows the testing arrangement.

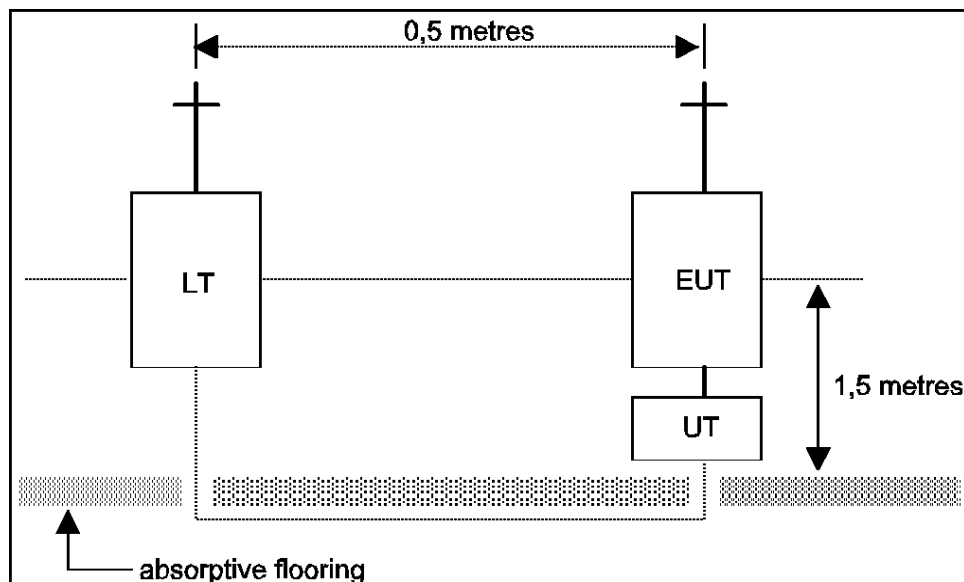

Figure 22: Testing arrangement

The elevation of the antennas is the same. Absorptive flooring is used to minimize reflection effects. The link between the UT and the EUT indicates the control of the EUT via the DECT air interface.

5.1.14.2 FT to FT arrangement

In the FT to FT situation, the minimum distance for non-interference operation is specified as being 1 m. Figure 23 shows the testing arrangement.

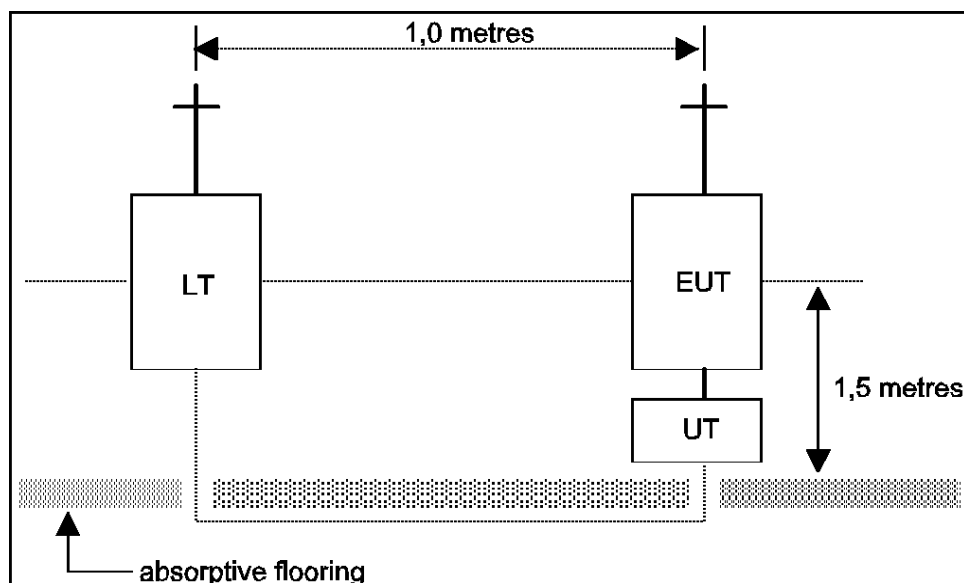

Figure 23: Testing arrangement

The elevation of the antennas is the same. Absorptive flooring is used to minimize reflection effects. The link between the UT and the EUT indicates the control of the EUT via the DECT air interface.

5.1.14.3 FT to PT arrangement

In the FT to PT situation, the minimum distance for non-interference operation is specified as being 1 m in this case the test arrangement shown previously in figure 23 is reused.

The elevation of the antennas is the same. Absorptive flooring is used to minimize reflection effects. The link between the UT and the EUT indicates the control of the EUT via the DECT air interface.

5.1.15 Test conditions, power supply and ambient temperatures

5.1.15.1 General

The following conditions shall apply during all tests:

- atmospheric pressure: 86 kPa to 106 kPa;
- Relative Humidity (RH): 5 % to 75 % non-condensing.

The temperature conditions and voltage supply applied in each test are specified as either nominal or extreme. The definitions of nominal and extreme are contained in clauses 5.1.15.2 and 5.1.15.3. Each test case defines whether nominal or extreme conditions apply. In some test cases only extreme temperature conditions apply and this is stated in the appropriate test case.

Before measurements are made, the equipment shall have reached thermal equilibrium in the test chamber. The equipment shall be switched off during the temperature stabilizing period. If the thermal equilibrium is not checked by measurements, a temperature stabilizing period of at least one hour, or such period as may be decided by the test laboratory, shall be allowed.

Before the start of a test, but after reaching thermal equilibrium in the test chamber, the equipment shall be powered up. For RFPs, the time between power-up and the start of testing shall be greater than 15 minutes. For PPs, testing may commence any time after 1 minute after power-up.

The sequence of measurements shall be chosen, and the humidity content in the test chamber shall be controlled, so that condensation does not occur.

It is not necessary to control the atmospheric pressure during testing.

When it is impractical to carry out the tests under these conditions, a statement giving the actual temperature and relative humidity during the tests shall be recorded in the test report.

5.1.15.2 Nominal test conditions

These are identical for all types and classes of equipment. This is clarified by figures 24, 25 and 26.

PP:

	VOLTAGE		
	MIN	NOM	MAX
0°			
+15° to +35°		<input checked="" type="checkbox"/>	
+40°			

Figure 24: Nominal test condition for PPs

FP, RFP, CCFP for Class E1 use:

	VOLTAGE		
	MIN	NOM	MAX
+10°			
+15° to +35°		<input checked="" type="checkbox"/>	
+40°			

Figure 25: Nominal test condition for Class E1

FP, RFP, CCFP for Class E2 use:

	VOLTAGE		
	MIN	NOM	MAX
-10°			
+15° to +35°		☑	
+55°			

Figure 26: Nominal test condition for Class E2

For nominal temperature, each measurement is made at the temperature of the test site, which shall be within +15 °C to +35 °C.

5.1.15.3 Extreme test conditions

The extreme test conditions are determined by the type of equipment under test. Figures 27, 28 and 29 class the EUT as either PP, FP, RFP or CCFP (see clause 3.1 for definitions).

In addition, FPs, RFPs and CCFPs shall be classed as either for Class E1 use or Class E2 use. Class E1 use refers to indoor areas allowing for personal comfort, for example, homes, offices, laboratories or workshops. Class E2 use refers to all other areas.

For the extreme test conditions, measurements shall be done at the four combinations of extreme temperatures and extreme voltages. The specified extreme temperatures depend on the type of equipment and for FPs, RFPs and CCFPs, of the Class (E1 or E2) and are given in figures 27 to 29. The temperature shall be set with a tolerance of ± 1 °C.

The definitions of minimum, nominal and maximum applied voltage are contained in clauses 5.1.15.5 and 5.1.15.6.

In addition to that, any extreme conditions test shall also be passed at nominal temperature / voltage conditions. This is reflected as a fifth "check-mark" placed at the centre in figures 27 to 29.

PP:

	VOLTAGE		
	MIN	NOM	MAX
0°	☑		☑
+15° to +35°		☑	
+40°	☑		☑

Figure 27: Extreme test condition for PPs

FP, RFP, CCFP for Class E1 use:

	VOLTAGE		
	MIN	NOM	MAX
+10°	☑		☑
+15° to +35°		☑	
+40°	☑		☑

Figure 28: Extreme test condition for Class E1

FP, RFP, CCFP for Class E2 use:

	VOLTAGE		
	MIN	NOM	MAX
-10°	☑		☑
+15° to +35°		☑	
+55°	☑		☑

Figure 29: Extreme test condition for Class E2

5.1.15.4 Test power source - general requirements

During the type tests, the power source of the equipment shall be replaced by a test power source, capable of producing normal and extreme test voltages as specified in clauses 5.1.15.5 and 5.1.15.6. The internal impedance of the test power source shall be low enough for its effect on the test results to be negligible. For the test purposes, the voltage of the power source shall be measured at the input terminals of the equipment.

If the equipment is provided with a permanently connected power cable, the test voltage shall be measured at the point of connection of the power cable to the equipment.

In equipment with incorporated batteries, the test power source shall be applied as close to the battery terminals as is practical. In each case connections shall be made readily available by the manufacturer.

During tests, the power source voltages shall be maintained within a tolerance of ± 3 % relative to the voltage at the beginning of each test.

5.1.15.5 Nominal test power source

5.1.15.5.1 Mains voltage

The normal test voltage for equipment to be connected to the mains shall be the nominal mains voltage. For the purpose of the present document, the nominal voltage shall be the voltage or voltages for which the equipment was designed in accordance with its intended use. The frequency of the test power source corresponding to the AC mains shall be between 49 Hz and 51 Hz.

5.1.15.5.2 Regulated lead acid battery power sources

When the radio equipment is intended for operation from a lead-acid chemistry battery source, the source voltage used during testing shall be 1,1 times the nominal voltage of the battery (i.e. $1,1 \times \text{number of cells} \times 2 \text{ V/cell}$).

5.1.15.5.3 Nickel cadmium or nickel metal hydride battery

When the equipment is intended for operation from a nickel-cadmium or a nickel metal hydride chemistry battery source, the source voltage used during testing shall be the nominal voltage of the battery (1,2 V/cell).

5.1.15.5.4 Other power sources

For operation from other power sources or types of battery, either primary or secondary, the normal test source voltage shall be in accordance with its intended use.

5.1.15.6 Extreme test power source

5.1.15.6.1 Mains voltage

The extreme test source voltages for equipment to be connected to an AC mains source shall be the nominal mains voltage ± 10 %. The frequency of the test power source shall be between 49 Hz and 51 Hz.

5.1.15.6.2 Regulated lead acid battery power sources

When the equipment is intended for operation from the usual type of regulated lead acid battery source, the extreme test voltages shall be 1,3 and 0,9 times the nominal voltage of the battery.

5.1.15.6.3 Nickel cadmium or nickel metal hydride battery

When the equipment is intended for operation from the usual type of nickel cadmium or nickel metal hydride battery, the extreme test voltages shall be 1,25 and 0,9 times the nominal voltage of the battery.

5.1.15.6.4 Other power sources

The lower extreme test voltage for equipment with power sources using primary batteries shall be as follows:

- a) for Leclanché type of battery: 0,85 times the nominal voltage;
- b) for other types of primary battery: the end point voltage in accordance with its intended use.

The upper extreme test voltage shall be the nominal voltage of the battery.

For equipment using other power sources, or capable of being operated from a variety of power sources, or designed for operation within extreme voltage limits not in accordance with those quoted above the extreme test voltages shall be those agreed between the manufacturer and the test laboratory and shall be recorded with the test results.

Figure 30: Void

5.2 Interpretation of the measurement results

The interpretation of the results recorded in a test report for the measurements described in the present document shall be as follows:

- The measured value related to the corresponding limit will be used to decide whether an equipment meets the requirements of the present document. The value of the measurement uncertainty for the measurement of each parameter shall be included in the test report.

Informative values in table F.1 can be used for the interpretation of the results.

5.3 Radio test suites

5.3.1 Accuracy and stability of RF carriers

5.3.1.1 Test environment

The test shall take place at a test site or in a test fixture.

If the EUT has an antenna connector then it shall be used to connect the EUT to the LT.

The test shall take place under extreme test conditions.

5.3.1.2 Method of measurement

- a) The LT shall place the EUT in a mode whereby the EUT is positioned in a LT specified slot and RF channel1c = 5. If so equipped, the handover function in the EUT shall be disabled (see clause 5.1.10.3 for the appropriate test message reference).
- b) The EUT shall be placed in a test mode whereby it performs the loopback function as referenced in clause 5.1.10.3.
- c) The LT shall transmit a packet with a test sequence in the loopback field of the packet. This test sequence shall be such that the sequence 0000 1111 0000 1111 is transmitted at the antenna of the EUT in the loopback field of the reply packet.
- d) Using the sampling method described in clause 5.1.12.2.2, capture a representation of the EUT's transmitted RF signal after allowing the EUT to be in an active-locked state (see ETSI EN 300 175-3 [2]) for more than 1 s.
- e) The EUT's carrier frequency for d) shall be assumed to be the average of the measured absolute frequencies of the loopback bits.

- f) Steps c) to e) shall be repeated until the number of measurements given in table 12 has been made:

Table 12: Measurement repetition

Equipment type	Number of measurements
A-field only transmit	100
Half-slot transmit	40
Full-slot transmit	10
Variable length slot with $j = 640$ transmit	5
Double-slot transmit	5

The centre frequency of the EUT is taken to be the mean value of the measurements.

- g) Steps c) to f) shall be repeated for all combinations of temperatures and power supply voltages allowed under extreme test conditions.
- h) Steps c) to g) shall be repeated for RF channels $c = 0$ and 9.
- i) When the EUT is a PP, then c) to h) shall be repeated, with the addition that the RF signal is sampled (in d)) during the first 1 s of the EUT going into a transmit mode from a non-transmitting mode. If necessary a) and b) may be repeated as required in order to make the number of measurements specified in f).

5.3.1.3 Verdict criteria when the EUT is a RFP

The results obtained shall be compared to the limits in clause 4.5.1.2 in order to prove compliance with the requirement.

5.3.1.4 Verdict criteria when the EUT is a PP

Case 1: When the measurement is made during the first 1 s of the EUT going into a transmit mode from a non-transmitting mode:

The results obtained shall be compared to the limits in clause 4.5.1.2 in order to prove compliance with the requirement.

Case 2: When the measurement is made at any other time:

The results obtained shall be compared to the limits in clause 4.5.1.2 in order to prove compliance with the requirement.

5.3.2 Accuracy and stability of timing parameters

5.3.2.1 Measurement of packet timing jitter

5.3.2.1.1 Test environment

The test shall take place at a test site or in a test fixture. If the EUT is equipped with a temporary connector, the temporary connector may be used in place of the test fixture for this test.

If the EUT has an antenna connector then it shall be used to connect the EUT to the LT.

The test shall take place under extreme test conditions.

5.3.2.1.2 Method of measurement

- a) The LT shall place the EUT in a mode whereby the EUT is positioned in a LT specified slot and frequency. If so equipped, the handover function in the EUT shall be disabled (see clause 5.1.10.3 for the appropriate test message reference).

The manufacturer shall declare to the testing laboratory the time required for system synchronization by the EUT.

- b) Using a sampling method, capture a representation of the RF signal transmitted by the EUT on the same slot position in 2 consecutive frames.

- c) The LT shall determine the positions of p0 in the slots that were sampled in step b) above. See figure 31.
- d) Steps b) and c) shall be repeated 1 000 times.
- e) The reference time is the mean of the values measured in c) through d). The deviation of the maximum and minimum values from the mean is the packet timing jitter.

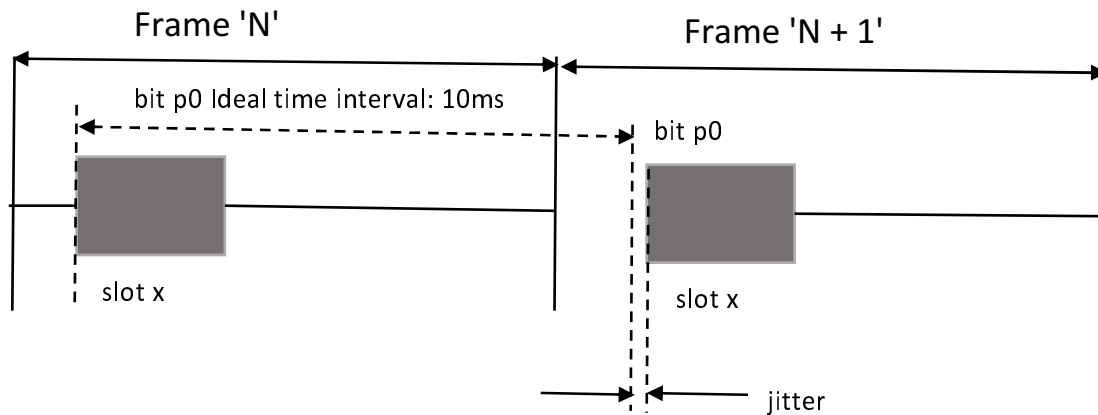

Figure 31: Jitter definition

5.3.2.1.3 Verdict criteria

The measured results for packet timing jitter shall be compared to the limits in clause 4.5.2.2.2 in order to prove compliance with the requirement.

5.3.2.2 Measurement of the reference timing accuracy of a RFP

5.3.2.2.1 Test environment

The test shall take place at a test site or in a test fixture. If the EUT is equipped with a temporary connector, the temporary connector may be used in place of the test fixture for this test.

If the EUT has an antenna connector then it shall be used to connect the EUT to the LT.

The test shall take place under extreme test conditions.

5.3.2.2.2 Method of measurement

- a) A minimum of one duplex bearer shall be setup between the LT and the EUT.
- b) Using a sampling method, measure the time, t_{long} , between the transmission of 1 000 frames using the same bit in each slot as the point of reference in each frame.

5.3.2.2.3 Verdict criteria

The EUT is required to conform to the timing accuracies and stabilities of table 13 at all the applied voltage conditions.

Table 13: Reference timing accuracy and stability

Type of EUT	Temperature	
	Nominal	Extreme
Multiple Channel RFP	5 ppm	10 ppm
Single Channel RFP	No test	10 ppm

t_{long} , as measured, shall be within the range of values given in table 14.

Table 14: Allowable timing variations

Timing Accuracy and Stability (ppm)	Ranges of t_{long} Constituting a Pass (seconds)
5	$9,99995 < t_{long} < 10,00005$
10	$9,99990 < t_{long} < 10,00010$

RFPs that can work with more than one duplex pair of physical channels per frame are known as multi-channel RFPs. Single channel RFPs can only work with one duplex pair of physical channels per frame (excluding handover situations).

The results obtained shall be compared to the limits in clause 4.5.2.2.1 in order to prove compliance with the requirement.

5.3.2.3 Measurement of packet transmission accuracy of a PP

5.3.2.3.1 Test environment

The test shall take place at a test site or in a test fixture. If the EUT is equipped with a temporary connector, the temporary connector may be used in place of the test fixture for this test.

If the EUT has an antenna connector then it shall be used to connect the EUT to the LT.

If the EUT has the facilities for advancing the transmission timing from the nominal then this shall be disabled for the duration of this test.

The test shall take place under extreme test conditions.

5.3.2.3.2 Method of measurement

- a) The LT shall place the EUT in a mode whereby the EUT is positioned in a LT specified slot and channel number $c = 5$. If so equipped, the handover function in the EUT shall be disabled. See clause 5.1.10.3 for the appropriate test message reference. The manufacturer shall declare to the testing laboratory the time required for a system synchronization by the EUT.
- b) Using a sampling method, capture a representation of the RF signal transmitted by the LT and EUT 12 slots apart in the same frame. See figure 32.
- c) The LT shall determine the positions at the EUT of p_0 in the slots that were sampled in part b) above.
- d) The delay shall be calculated as the difference in time between the p_0 of the LT and the p_0 of the EUT.
- e) Steps b) through to d) shall be repeated 100 times.
- f) Steps b) through to e) shall be repeated for RF channels $c = 0$ and 9.
- g) The minimum and maximum delays shall be found over all measurements.

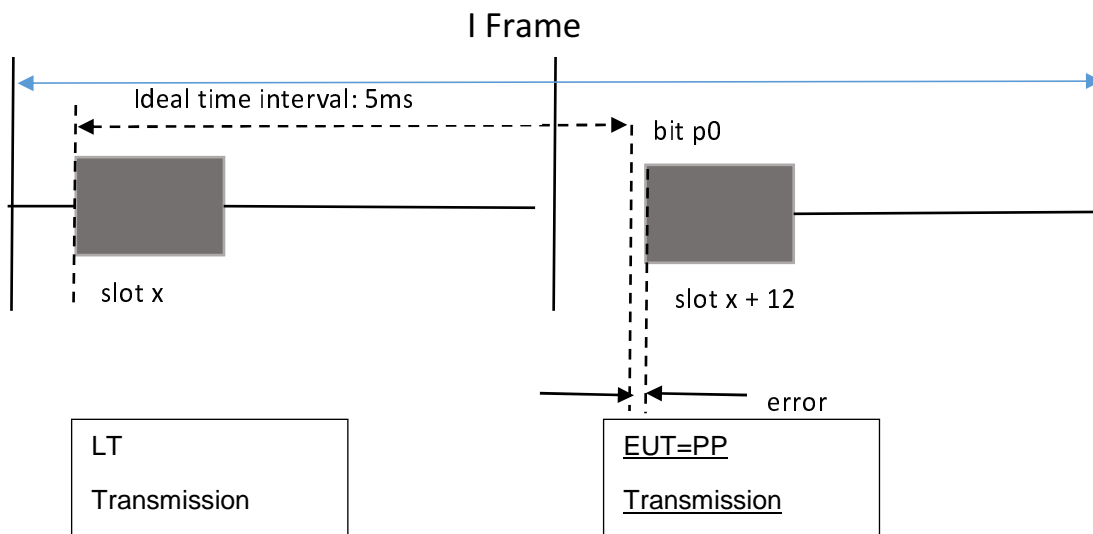

Figure 32: PP packet transmission error definition

5.3.2.3.3 Verdict criteria

The results obtained shall be compared to the limits in clause 4.5.2.2 in order to prove compliance with the requirement.

5.3.3 Transmission burst

5.3.3.1 Test environment

If the EUT has an antenna connector then it shall be used to connect the EUT to the LT.

The test shall take place under nominal and extreme temperature conditions at the nominal supply voltage.

This test shall take place either at a test site, in an anechoic chamber, clause 5.1.2.2, or in a test fixture for the nominal temperature condition. The extreme temperature testing shall take place inside a temperature chamber with the EUT mounted in a test fixture.

5.3.3.2 Method of measurement

- The LT shall place the EUT in a mode whereby the EUT is transmitting at a LT specified slot and RF channel $c = 5$. If so equipped, the handover function in the EUT shall be disabled (see clause 5.1.10.3 for the appropriate test message reference).
- Using a sampling measurement method, capture a representation of the EUT's transmit burst's amplitude and modulation. The measurement bandwidth for RF power shall be 1 MHz for the measurement of transmitter idle power (see clause 4.5.3.1.9) and ≥ 3 MHz for all other.
- From the array of samples the LT shall calculate the position of bit p0 and the end of the physical packet in each sample to an accuracy of $0,1 \mu\text{s}$.
- Steps b) and c) are repeated 60 times with intervals of 1 s or longer.
- Steps a) to d) shall be repeated for RF channels $c = 0$ and 9.

5.3.3.3 Verdict criteria

The array of power samples shall be compared for a fit within the power-time template as shown in figure 33 and shall comply with the requirements in clauses 4.5.3.1.4, 4.5.3.1.5, 4.5.3.1.6, 4.5.3.1.7, 4.5.3.1.8 and 4.5.3.1.9.

The sampled bursts, as measured, shall conform to the power-time template.

As described in clause 4.5.3.1.9, the 20 nW power envelope shown in figure 33 is only applicable when the time between the end of a physical packet and the transmission of p0 of the next physical packet is greater than 54 μ s.

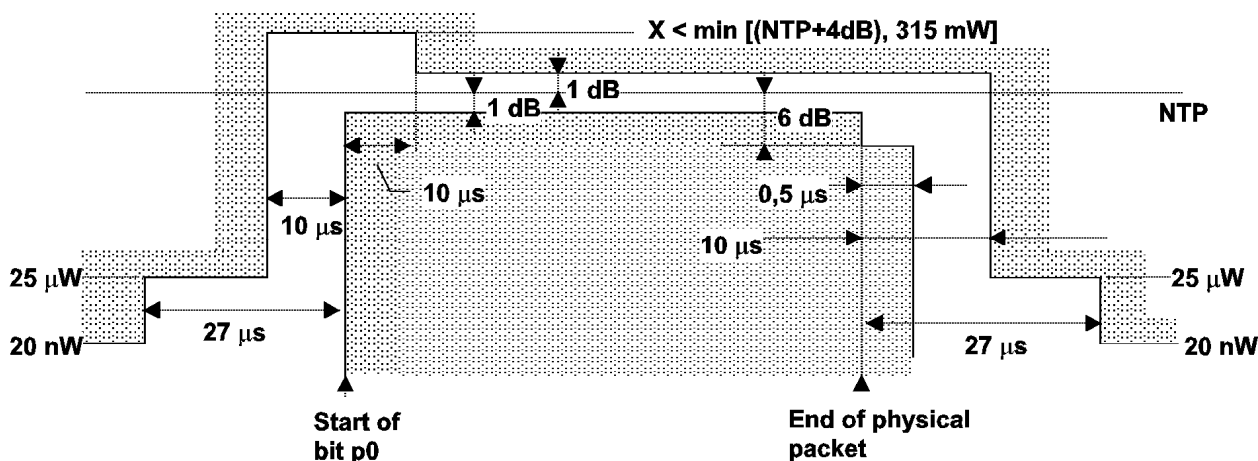

Figure 33: Power-time template

For packets with prolonged preamble, the verdict criteria apply with the notation p0 generally changed to p-16 and the EUT shall implement the procedure defined in ETSI EN 300 175-2 [1], annex C.

The results obtained shall be compared to the limits in clause 4.5.3.2 in order to prove compliance with the requirement.

5.3.4 Transmitted power

5.3.4.1 PP and RFP with an integral antenna

5.3.4.1.1 Test environment

The test shall take place under nominal temperature conditions and at a nominal supply voltage.

This test shall take place either at a test site or in an anechoic chamber (see clause 5.1.2.2) for the nominal temperature condition.

5.3.4.1.2 Method of measurement

5.3.4.1.2.1 Introduction

The test consists of both a conducted and a radiated power measurement. For the conducted power measurement, the EUT shall be equipped with a temporary antenna connector. The radiated measurement is performed on a EUT with its own integral antenna.

5.3.4.1.2.2 Measurement of NTP

The test described in clause 5.3.4.2.2 shall be performed on the EUT with the temporary connector.

The measured result is the NTP.

5.3.4.1.2.3 Measurement of antenna gain

The following measurement is done on the EUT with its own integral antenna:

- if the EUT incorporates antenna diversity, then the LT shall command the EUT to operate on a single antenna (see clause 5.1.10.3 for the appropriate test message reference);
- the LT shall place the EUT in a mode whereby the EUT is positioned in a LT specified slot and frequency. If so equipped, the handover function in the EUT shall be disabled (see clause 5.1.10.3 for the appropriate test message reference);

- c) a test antenna with a good directivity to limit reflections is connected to a calibrated receiver. The manufacturer shall indicate the polarization of the integral antenna so that the test antenna can be set to the same polarization as the integral antenna of the EUT throughout this test. The test antenna shall be raised or lowered until a maximum received signal is obtained, except when using a fully anechoic chamber (see clause 5.1.2.2):
 - The EUT shall be orientated in the reference position using the procedure described in clause 5.1.12.3;
- d) at this position, the LT shall:
 - 1) use the sampling method described in clause 5.1.12.2.2 to capture a representation of a physical packet transmitted by the EUT;
 - 2) determine the position of p₀ in the physical packet and the end of the physical packet;
 - 3) make a measurement of the received power over the 1 MHz bandwidth centered on the DECT RF channel. This power shall be averaged from the start of bit p₀ to the end of the physical packet. This measurement shall be called P_R;
- e) the substitution antenna shall replace the EUT's transmitter antenna in the same position and polarization. The frequency of the signal generator shall be adjusted to the EUT's nominal channel frequency on which it was transmitting. The test antenna shall be raised or lowered as necessary to ensure that the maximum signal level is received, except when using a fully anechoic chamber (clause 5.1.2.2). The input signal level to the substitution antenna shall be adjusted until an equal or a known related level to P_R is obtained in the test receiver:
 - P_T is equal to the power supplied by the signal generator, increased by the known related level if necessary and after corrections due to the gain of the substitution antenna and the cable loss between the signal generator and the substitution antenna;
- f) the antenna gain is the ratio (in dB) between the radiated power P_T and the NTP;
- g) steps b) to f) shall be performed for RF channels c = 0, 5 and 9.

5.3.4.1.2.4 Determination of EIRP

The following steps are done:

- a) measurement of NTP as described in clause 5.3.4.1.2.2;
- b) measurement of antenna gain as described in clause 5.3.4.1.2.3;
- c) EIRP = NTP + antenna gain.

5.3.4.1.3 Verdict criteria for all EUTs

The NTP per simultaneously active transceiver, as measured, shall be less than P_{NTP}.

The antenna gain as measured shall be less than 12 dB plus the ratio (in dB) between P_{NTP} (250 mW) and NTP.

The results obtained shall be compared to the limits in clause 4.5.4.2 in order to prove compliance with the requirement.

5.3.4.2 PP and RFP with external antenna connection(s)

5.3.4.2.1 Test environment

The test shall take place under extreme temperature conditions and at a nominal supply voltage.

This test shall take place either at a test site or in an anechoic chamber (clause 5.1.2.2) for the nominal temperature condition. The extreme temperature testing shall take place inside a temperature chamber.

The EUT shall be connected to the LT via the antenna connector(s).

5.3.4.2.2 Method of measurement

- a) If the EUT incorporates antenna diversity, then the LT shall command the EUT to operate on a single external antenna (see clause 5.1.10.3 for the appropriate test message reference).
- b) The LT shall place the EUT in a mode whereby the EUT is positioned in a LT specified slot and frequency. If so equipped, the handover function in the EUT shall be disabled (see clause 5.1.10.3 for the appropriate test message reference).
- c) A test load shall be connected to each antenna connector.
- d) The LT shall:
 - 1) use the sampling method described in clause 5.1.12.2.2 to capture a representation of a physical packet transmitted by one of the antenna connectors of the EUT into the test load;
 - 2) determine the position of p0 in the physical packet and the end of the physical packet;
 - 3) make a measurement of the power over the 1 MHz bandwidth centered on the DECT RF channel. This power shall be the power delivered to each load simultaneously, averaging from the start of bit p0 of the physical packet, to the end of the physical packet that was sampled in 1).
- e) Steps b) to d) shall be performed for RF channels $c = 0, 5, \text{ and } 9$.

When there is more than one antenna port, the instantaneous power from each antenna port shall be added together. The sum shall be called the NTP.

5.3.4.2.3 Verdict criteria for all EUTs

The NTP per simultaneously active transceiver, as measured, shall be less than P_{NTP} .

The results obtained shall be compared to the limits in clause 4.5.4.2 in order to prove compliance with the requirement.

5.3.5 RF carrier modulation

5.3.5.1 Test environment

The test should preferably take place at a test site, otherwise a test fixture or temporary connector shall be used.

If the EUT has an antenna connector then it shall be used to connect the EUT to the LT.

The test shall take place under nominal supply voltage conditions and at a nominal temperature.

5.3.5.2 Method of measurement, parts 1 and 2

5.3.5.2.1 Introduction

The measurement period of a single positive or negative deviation measurement shall begin one bit time after a 0 to 1 or a 1 to 0 transition in the test data pattern. The measurement period shall end one bit time before the next 0 to 1 or 1 to 0 transition.

In the cases below, the calculation of the **peak frequency deviation** is defined as the difference between the minimum and maximum extent of a **frequency modulated** signal, and the nominal centre or carrier **frequency**.

5.3.5.2.2 Part 1

- a) Repeat steps a) to d) of clause 5.3.1.2.
- b) Using the samples that were obtained from a), the LT shall calculate the peak frequency deviation within each bit period defined in clause 5.3.5.2.1 in the loopback field of the transmit burst of the EUT, relative to the measured carrier frequency that was calculated in clause 5.3.1. The measurement bandwidth shall be ≥ 3 MHz.
- c) Steps a) to b) shall be repeated until the number of measurements given in table 15 has been made.

Table 15: Measurement repetition

Equipment type	Number of measurements
A-field only transmit	100
Half-slot transmit	40
Full-slot transmit	10
Variable length slot with $j = 640$ transmit	5
Double-slot transmit	5

5.3.5.2.3 Part 2

- a) Steps a) to d) of clause 5.3.1.2 shall then be repeated using the appropriate sequences listed in table 16.

Table 16: Test sequence

Equipment type	Test pattern
A-field only transmit	Figure 34
Half-slot transmit	Figure 35
Full-slot transmit	Figure 36
Variable length slot with $j = 640$ transmit	Figure 37
Double-slot	Figure 38

- b) Using the samples that were obtained from part (a) above, the LT shall calculate the peak frequency deviation within each bit period defined in clause 5.3.5.2.1 in the loopback field of the transmit burst of the EUT, relative to the measured carrier frequency that was calculated in clause 5.3.1. The measurement bandwidth shall be ≥ 3 MHz.
- c) Steps a) to b) shall be repeated until the number of measurements given in table 17 has been made.

Table 17: Measurement repetition

Equipment type	Number of measurements
A-field only transmit	100
Half-slot transmit	40
Full-slot transmit	10
Variable length slot with $j = 640$ transmit	5
Double-slot transmit	5

5.3.5.3 Method of measurement, parts 3 and 4

5.3.5.3.0 General

The measurement period for the deviation measurement shall begin one bit time after the first 0 to 1 or 1 to 0 transition. The measurement period shall end one bit time before the last 0 to 1 or 1 to 0 transition.

5.3.5.3.1 Part 3

- a) Steps a) to d) of clause 5.3.1.2 shall be repeated with the sequence "0101 0101 0101 0101".
- b) Using the samples that were obtained from part a) above, the LT shall calculate the peak frequency deviation within each bit period in the first 16 bits of the synchronization field (preamble) and the loopback field of the transmit burst of the EUT, relative to the measured carrier frequency that was calculated in clause 5.3.1. The measurement bandwidth shall be ≥ 3 MHz.
- c) Steps a) to b) shall be repeated until the number of measurements given in table 18 has been made.

Table 18: Measurement repetition

Equipment type	Number of measurements
A-field only transmit	100
Half-slot transmit	40
Full-slot transmit	10
Variable length slot with $j = 640$ transmit	5
Double-slot transmit	5

5.3.5.3.2 Part 4

- a) The LT shall place the EUT in a mode whereby the EUT is positioned in a LT specified slot and frequency. If so equipped, the handover function in the EUT shall be disabled (see clause 5.1.10.3 for the appropriate test message reference).
- b) The EUT shall be placed in a test mode whereby it performs the loopback function as referenced in clause 5.1.10.3.
- c) The LT shall transmit a packet with a test sequence in the loopback field of the packet. This test sequence shall be such that the sequence 0101 0101 0101 0101 is transmitted at the antenna of the EUT in the loopback field of the reply packet.
- d) Using the sampling method described in clause 5.1.12.2.2 capture a representation of the EUT's transmitted RF signal after allowing the EUT to be in an Active-locked state (see ETSI EN 300 175-3 [2]) for more than 1 s. The measurement bandwidth shall be ≥ 3 MHz.
- e) Using the samples that were obtained from d) above, the LT shall calculate the average frequency of the last 14 bits of the first 16 bits of the synchronization field.
- f) Using the samples that were obtained from d) above, the LT shall calculate the average frequency of the first 14 bits of the last 16 bits of the loopback field.
- g) Steps c) to f) shall be repeated until 200 measurements have been made. The frequency drift is the difference between the mean of the measurements taken in e) and the mean of the measurements taken in f).

5.3.5.4 Verdict criteria for part 1

The results obtained shall be compared to the limits in clause 4.5.5.2 in order to prove compliance with the requirement.

5.3.5.5 Verdict criteria for part 2

The results obtained shall be compared to the limits in clause 4.5.5.2 in order to prove compliance with the requirement.

5.3.5.6 Verdict criteria for part 3

The results obtained shall be compared to the limits in clause 4.5.5.2 in order to prove compliance with the requirement.

5.3.5.7 Verdict criteria for part 4

The rate of change as measured in part 4 shall not be greater than 15 kHz per slot plus the maximum measurement uncertainty calculated from the allowable uncertainty in the relative drift radio frequency measurements involved (see clause 5.2). This implies that the drift in slot shall be between -16 kHz per slot and +16 kHz per slot, as measured.

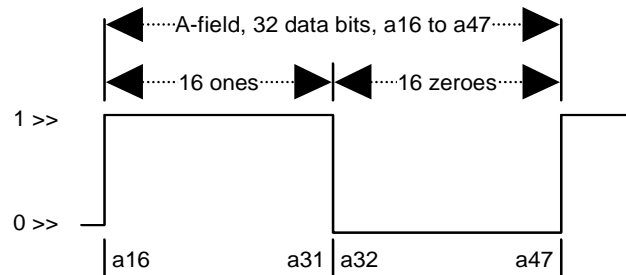
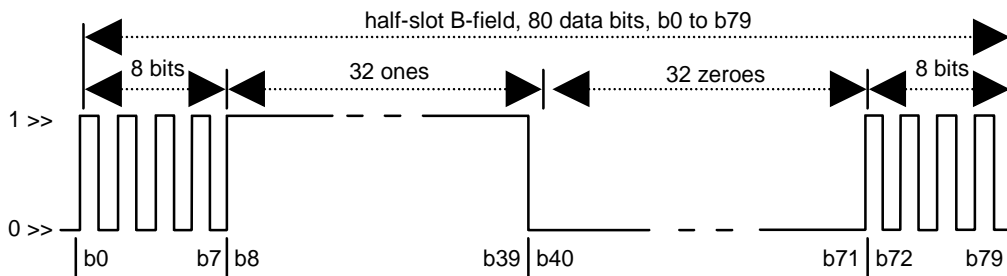
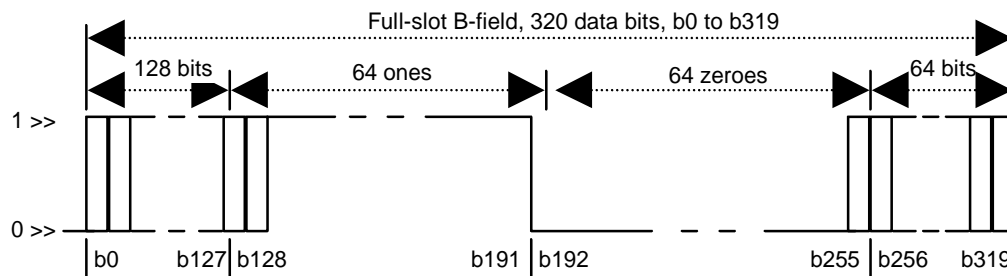

Figure 34: Test packet structure for case 2, A-field



NOTE: Bits b_0 to b_7 and b_{72} to b_{79} are alternating 1 s and 0 s with the even order bits (b_0, b_2, b_4, \dots) set to "1" and the odd-order bits (b_1, b_3, b_5, \dots) set to "0".

Figure 35: Test packet structure for case 2, half-slot



NOTE: Bits b_0 to b_{127} and b_{256} to b_{319} are alternating 1 s and 0 s.

Figure 36: Test packet transmission for case 2, full-slot

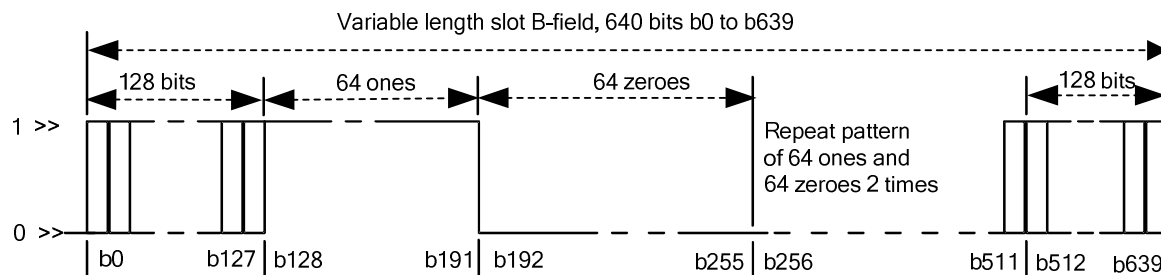

NOTE: Bits b_0 to b_{127} and b_{512} to b_{639} are alternating 1 s and 0 s.

Figure 37: Test packet transmission for case 2, variable length slot with $j = 640$

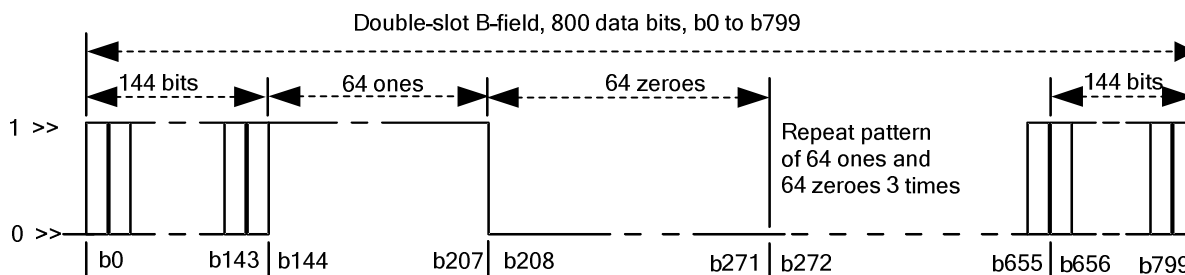

NOTE: Bits b_0 to b_{143} and b_{656} to b_{799} are alternating 1 s and 0 s.

Figure 38: Test packet transmission for case 2, double-slot

NOTE: The above fields, (A-field for figure 34, half-slot for figure 35, full-slot for figure 36, variable length slot with $j = 640$ for figure 37, and double-slot for figure 38) are defined in ETSI EN 300 175-3 [2]. The X-field portions of the half-slot, full-slot, variable length slot and double-slot B-fields depicted in figures 35, 36, 37 and 38 are not shown.

The results obtained shall be compared to the limits in clause 4.5.5.2 in order to prove compliance with the requirement.

5.3.6 Unwanted RF power radiation

5.3.6.1 General test conditions

If the EUT is equipped with antenna diversity, the EUT shall have the diversity operation defeated for the following tests (see clause 5.1.10.3 for the appropriate test message reference).

5.3.6.2 Emissions due to modulation

5.3.6.2.1 Test environment

The test shall take place at a test site or using a test fixture for equipment with integral antenna or an external antenna connector.

The test shall take place under nominal supply voltage conditions and at a nominal temperature.

5.3.6.2.2 Method of measurement

- a) If the EUT has an external antenna connector then this shall be used to connect the EUT to the LT. Otherwise, the transmitted signal shall be applied to the LT via a coupling device which provides the appropriate signal level to the system. The analysingsystem in the LT shall be operated under the following conditions:
 - frequency sweep: 1 MHz;

- resolution bandwidth: 100 kHz;
- video bandwidth: greater than resolution bandwidth;
- integration: across the frequency sweep;
- peak hold: on;
- sweep time: greater than 12 seconds;
- filtering type: synchronously tuned.

The centre frequencies of the DECT RF channels are defined in clause 4.5.1.1.

The total sample time used for measurement is 60 % to 80 % of the duration of the physical packet, starting before 25 % of the slot time has expired but after the transmission of the synchronization word. The LT shall determine the start of the physical packet (bit p0) transmitted by the EUT.

- b) The LT shall place the EUT in a mode whereby the EUT is positioned in a LT specified slot and frequency. If so equipped, the handover function in the EUT shall be disabled. See clause 5.1.10.3 for the appropriate test message reference.
- c) The EUT shall be placed in a test mode whereby it performs the loopback function as referenced in clause 5.1.10.3.
- d) A test modulation signal D - M2 (see clause 5.1.9.8) is generated by the LT.
- e) Using the analysing system, a measurement of the EUT's transmitted power on channel M is made during the sampling time. This power measurement shall be called P_{ref} .

NOTE: This measurement becomes the reference power for the power measurements of the other channels.

- f) Using the method described in e), a measurement on all the other DECT channels shall be made and recorded in dB as a value relative to P_{ref} . These shall be called P_{rm-2} , P_{rm-1} , P_{rm+1} , P_{rm+2} , etc., corresponding to the measurements made on channels $Y = M - 2$, $Y = M - 1$, $Y = M + 1$ and $Y = M + 2$.
- g) Using the measured value of transmitted power, NTP, from clause 5.3.4.2.2 for channel $Y = M$, the LT shall calculate the power emissions on each channel.

EXAMPLE: Emissions on channel $Y = M + 1$:

$$= NTP(\text{dBm}) + P_{rm+1}(\text{dB}).$$

- h) The value calculated in g) shall be converted from dBm to Watts.
- i) Steps b) through h) shall be performed with the EUT's transmitter placed on DECT RF channels $c = 0, 5$ and 9 .

5.3.6.2.3 Verdict criteria

The results obtained shall be compared to the limits in clause 4.5.6.2.2 in order to prove compliance with the requirement.

5.3.6.3 Emissions due to transmitter transients

5.3.6.3.1 Test environment

The test shall take place at a test site or using a test fixture for equipment with integral antenna or an external antenna connector.

The test shall take place under nominal supply voltage conditions and at a nominal temperature.

5.3.6.3.2 Method of measurement

- a) If the EUT has an external antenna connector then this shall be used to connect the EUT to the LT. Otherwise, the transmitted signal shall be applied to the LT via a coupling device which provides the appropriate signal level to the system. The analysingsystem in the LT shall be operated under the following conditions:
- frequency sweep: 1 MHz;
 - resolution bandwidth: 100 kHz;
 - video bandwidth: greater than resolution bandwidth;
 - averaging: none;
 - peak hold: on;
 - filtering type: 4 or 5 pole synchronously tuned.

The centre frequencies of the DECT RF channels are defined in clause 4.5.1.1.

- b) The LT shall place the EUT in a mode whereby the EUT is positioned in a LT specified slot and frequency. If so equipped, the handover function in the EUT shall be disabled (see clause 5.1.10.3 for the appropriate test message reference).
- c) The EUT shall be placed in a test mode whereby it performs the loopback function as referenced in clause 5.1.10.3. When testing a RFP, the test shall be performed either with the dummy bearer switched off when the traffic bearer is active, or with the dummy bearer placed on the same RF carrier as the traffic bearer as referenced in clause 5.1.10.4.
- d) A test modulation signal D - M2 (see clause 5.1.9.8) generated by the LT.
- e) The analysingsystem centre frequency is positioned at the centre of the DECT RF channel being measured.
- f) The analysingsystem should initiate a power measurement procedure conforming to the limits specified in annex F.
- g) Using the measured values obtained from e) to f), the LT shall select the highest recorded value within the sweep. This value shall be compared with the verdict criteria.
- h) Steps e) to g) are repeated for all DECT RF channels other than the one on which the EUT is transmitting.
- i) Steps b) to h) shall then be repeated until measurements have been made with the EUT's transmitter placed on all 10 DECT RF channels.

5.3.6.3.3 Verdict criteria

The results obtained shall be compared to the limits in clause 4.5.6.3.2 in order to prove compliance with the requirement.

5.3.6.4 Emissions due to intermodulation

5.3.6.4.1 Test environment

If the EUT is a PP equipped with an integral antenna, the EUT and the test antenna shall be mounted in the reference test arrangement as specified in clause 5.1.14.1.

If the EUT is a RFP with an integral antenna, the EUT and the test antenna shall be mounted in the reference testing arrangement as specified in clause 5.1.14.2.

If the EUT has an external antenna connector then this test shall preferably take place at a test site, otherwise a test fixture may be used.

The test shall take place under nominal supply voltage conditions and at a nominal temperature.

5.3.6.4.2 Method of measurement

- a) If the EUT has an external antenna connector then this shall be used to connect the EUT to the LT. Otherwise, the transmitted signal shall be applied to the LT via a coupling device which provides the appropriate signal level to the system. The analysingsystem in the LT shall be operated under the following conditions:
- frequency sweep: 1 MHz;
 - resolution bandwidth: 100 kHz;
 - video bandwidth: greater than resolution bandwidth;
 - integration: across the frequency sweep;
 - peak hold: on;
 - sweep time: greater than 12 seconds;
 - filtering type: synchronously tuned.

The centre frequencies of the DECT RF channels are defined in clause 4.5.1.1.

The total sample time used for measurement is 60 % to 80 % of the duration of the physical packet, starting before 25 % of the slot time has expired but after the transmission of the synchronization word. The LT shall determine the start of the physical packet (bit p0) transmitted by the EUT.

- b) The EUT shall be placed in a mode whereby two of the transceivers shall be made to operate on the same slot in the frame but on different DECT RF channels. The RF channels shall be $c = 0$ and $c = 9$. If so equipped, the handover function in the EUT shall be disabled (see clause 5.1.10.3 for the appropriate test message reference).
- c) The EUT shall be placed in a test mode whereby it performs the loopback function for both transceivers as referenced in clause 5.1.10.3.
- d) A test modulation signal D - M2 (see clause 5.1.9.5) is generated by the LT.
- e) Using the analysing system, a measurement of the transmitted powers on channels $M = 0$ and $M = 9$ shall be made during the sample time for a transmitter in the EUT. These measurements shall be called P_{ref0} and P_{ref9} .
- f) The EUT shall be placed in a mode whereby two of the transmitters shall be made to operate on the same slot in the frame but on different DECT RF channels. The RF channels shall be $M = 3$ and $M = 6$. If so equipped, the handover function in the EUT shall be disabled (see clause 5.1.10.3 for the appropriate test message reference).
- g) Using the analysing system, a measurement of the power levels on channels $c = 0$ and $c = 9$ shall be made during the sample time for a transmitter in the EUT. These power measurements shall be called P_{m0} and P_{m9} .
- h) Using the NTPs for $c = 0$ and $c = 9$ (as defined in clause 4.5.4), the LT shall calculate the power emissions on channels $c = 0$ and $c = 9$. The calculation shall be is performed as follows:
- 1) emissions on channel 0:

$$= NTP_0(\text{mW}) - P_{ref0}(\text{mW}) + P_{m0}(\text{mW});$$
 - 2) emissions on channel 9:

$$= NTP_9(\text{mW}) - P_{ref9}(\text{mW}) + P_{m9}(\text{mW}).$$
- i) Steps b) to h) shall be repeated until measurements have been made with all combinations of the EUT's transmitters.

5.3.6.4.3 Verdict criteria

The results obtained shall be compared to the limits in clause 4.5.6.4.2 in order to prove compliance with the requirement.

5.3.6.5 Spurious emissions when allocated a transmit channel

5.3.6.5.1 Radiated emissions

5.3.6.5.1.1 Test environment

The test shall take place at a test site.

For EUTs with external antenna connectors, test loads shall be attached to each connector.

The test shall take place under nominal supply voltage conditions and at a nominal temperature.

5.3.6.5.1.2 Method of measurement

- a) The analysing system in the LT shall be operated under the following conditions:
- frequency sweep: as required for frequency range;
 - resolution bandwidth: refer to table 17: Spurious emissions requirements of clause 4.5.6.5.2;
 - display bandwidth: greater than resolution bandwidth;
 - averaging: none;
 - peak hold: on;
 - filtering type: synchronously tuned.

The sweep time shall be chosen to be slow enough to ensure that the LT is capable of capturing at least one burst spurious signal for every measurement point.

NOTE: This may be achieved by using the following formula:

$$\text{sweep time} > \frac{2 \times (\text{PRI} \times \text{frequency span})}{\text{resolution bandwidth}}$$

where PRI = pulse repetition interval = 10 ms.

- b) Measurements shall not be made inside the DECT band and in the 2 MHz closest to the nearest band edges. In other words, spurious shall not be measured in the frequency range 1 878 MHz to 1 902 MHz.
- The centre frequencies of the DECT RF channels are defined in clause 4.5.1.1.
- c) The LT shall place the EUT in a mode whereby the EUT is positioned in a LT specified slot and frequency. If so equipped, the handover function in the EUT shall be disabled (see clause 5.1.10.3 for the appropriate test message reference).
- d) The EUT shall be placed in a test mode whereby it performs the loopback function as referenced in clause 5.1.10.3. When testing a RFP, the test shall be performed either with the dummy bearer switched off when the traffic bearer is active, or with the dummy bearer placed on the same RF carrier as the traffic bearer as referenced in clause 5.1.10.4.
- e) A test modulation signal D - M2 (see clause 5.1.9.5) is generated by the LT.
- f) The LT should initiate a power measurement procedure conforming to the limits specified in annex F.
- g) The test shall be carried out over the RF ranges from 30 MHz to 12,75 GHz and the power measurements shall be performed using the resolution bandwidth as indicated in table 7 of clause 4.5.6.5.2.

5.3.6.5.1.3 Verdict criteria

The results obtained shall be compared to the limits in clause 4.5.6.5.2 in order to prove compliance with the requirement.

5.3.6.5.2 Conducted spurious emissions when the EUT has a permanent external antenna connector

5.3.6.5.2.1 Test environment

The test shall take place under nominal supply voltage conditions and at a nominal temperature.

5.3.6.5.2.2 Method of measurement

- a) The EUT shall be connected to the LT via the permanent external antenna connector.
- b) The tests a) to g) in clause 5.3.6.5.1.2, shall be carried out.

NOTE: The methods described in annex C (conducted spurious emissions) can be used.

5.3.6.5.2.3 Verdict criteria

The results obtained shall be compared to the limits in clause 4.5.6.5.2 in order to prove compliance with the requirement.

5.3.7 Radio receiver testing

5.3.7.0 General

All radio receiver testing shall be performed in conducted mode only to ensure result accuracy and consistency is maintained throughout the test cycles.

5.3.7.1 Radio receiver sensitivity

5.3.7.1.1 Test environment

The test should preferably take place at a test site, otherwise a test fixture or temporary connector shall be used.

If the EUT has an antenna connector then it shall be used to connect the EUT to the LT.

The test shall take place under nominal supply voltage conditions and at a nominal temperature.

5.3.7.1.2 Method of measurement

- a) The EUT shall be oriented in the reference position as determined in clause 5.1.12.3 if no antenna connector is available.
- b) The LT shall be programmed to set its RF transmission to a power level such that -83 dBm shall be present at the input of the EUT receiver.
- c) The LT shall place the EUT in a mode whereby the EUT is positioned in a LT specified slot and RF channel $c = 5$. If so equipped, the handover function in the EUT shall be disabled (see clause 5.1.10.3 for the appropriate test message reference).
- d) The EUT shall be placed in a test mode whereby it performs the loopback function as referenced in clause 5.1.10.3.
- e) A test modulation signal D - M2 (see clause 5.1.9.8) is generated by the LT.
- f) The LT shall calculate the BER of the EUT as determined in clause 5.1.12.4 and annex D. Values in annex E can be used for BER calculations within the LT, when loss of synchronization is detected.
- g) The LT shall offset the frequency of the test signal by 50 kHz and repeat steps b) to f). This sequence of steps shall be repeated twice to include both positive and negative frequency offsets.
- h) Steps b) to f) shall be repeated for RF channels $c = 0$ and 9.

5.3.7.1.3 Verdict criteria

The results obtained shall be compared to the limits in clause 4.5.7.1.2 in order to prove compliance with the requirement.

5.3.7.2 Radio receiver reference BER and FER

5.3.7.2.1 Test environment

The test shall take place at a test site or using a test fixture for equipment with integral antenna.

If the EUT has an antenna connector then it shall be used to connect the EUT to the LT.

The test shall take place under nominal supply voltage conditions and at a nominal temperature.

5.3.7.2.2 Method of measurement

- a) The EUT shall be oriented in the reference position as determined in clause 5.1.12.3 if no antenna connector is available.
- b) The LT shall be programmed to set its RF transmission to a power level of -73 dBm at the input of the EUT receiver.
- c) The LT shall place the EUT in a mode whereby the EUT is positioned in a LT specified slot and RF channel $c = 5$ with handover disabled (see clause 5.1.10.3 for the appropriate test message reference).
- d) The EUT shall be placed in a test mode whereby it performs the loopback function as referenced in clause 5.1.10.3.
- e) A test modulation signal D - M2 (see clause 5.1.9.8) is generated by the LT.
- f) The LT shall calculate the BER and FER of the EUT as determined in clause 5.1.12.4 and annex D. Values in annex E can be used for BER calculations within the LT, when loss of synchronization is detected.
- g) Steps b) to f) shall be repeated for RF channels $c = 0$ and 9.

5.3.7.2.3 Verdict criteria

The results obtained shall be compared to the limits in clause 4.5.7.2.2 in order to prove compliance with the requirement.

5.3.7.3 Radio receiver interference performance

5.3.7.3.1 Test environment

The test shall take place at a test site or using a test fixture for equipment with integral antenna.

If the EUT has an antenna connector then it shall be used to connect the EUT to the LT.

The test shall take place under nominal supply voltage conditions and at a nominal temperature.

5.3.7.3.2 Method of measurement

- a) The EUT shall be oriented in the reference position as determined in clause 5.1.12.3 if no antenna connector is available.
- b) The LT shall be programmed to set its RF transmission to a power level of -73 dBm at the input of the EUT receiver.
- c) The LT shall place the EUT in a mode whereby the EUT is positioned in a LT specified slot and RF channel $c = 5$. If so equipped, the handover function in the EUT shall be disabled (see clause 5.1.10.3 for the appropriate test message reference).

- d) The EUT shall be placed in a test mode whereby it performs the loopback function as referenced in clause 5.1.10.3.
- e) A test modulation signal D - M2 (see clause 5.1.9.8) is generated by the LT.
- f) The LT shall transmit in addition to the D - M2 data test pattern, a modulated DECT - like carrier (see clause 5.1.9.5) on channel "Y" whose level is determined by table 8 of clause 4.5.7.3.2.
- g) The LT shall calculate the BER of the EUT as determined in clause 5.1.12.4 and annex D. Values in annex E can be used for BER calculations within the LT, when loss of synchronization is detected.
- h) Steps b) to g) shall be repeated so that the single interfering DECT - like carrier has been placed on all the remaining DECT channels. Table 8 indicates the amplitude of the interferer.
- i) Steps b) to h) shall be repeated for RF channels $c = 0$ and 9.

5.3.7.3.3 Verdict criteria

The results obtained shall be compared to the limits in clause 4.5.7.3.2 in order to prove compliance with the requirement.

5.3.7.4 Radio receiver blocking case 1: owing to signals occurring at the same time but on other frequencies

5.3.7.4.1 Test environment

The test shall take place at a test site or using a test fixture for equipment with integral antenna.

If the EUT has an antenna connector then it shall be used to connect the EUT to the LT.

The test shall take place under nominal supply voltage conditions and at a nominal temperature.

5.3.7.4.2 Method of measurement

- a) The EUT shall be oriented in the reference position as determined in clause 5.1.12.3 if no antenna connector is available.
- b) The power level of the RF transmission from the LT shall be set to -80 dBm.
- c) The LT shall place the EUT in a mode whereby the EUT is positioned in a LT specified slot and frequency (F_c). The frequency chosen shall be RF channel $c = 5$ of the DECT RF channels. If so equipped, the handover function in the EUT shall be disabled (see clause 5.1.10.3 for the appropriate test message reference).
- d) The EUT shall be placed in a test mode whereby it performs the loopback function as referenced in clause 5.1.10.3.
- e) A test modulation signal D - M2 (see clause 5.1.9.8) is generated by the LT.
- f) The LT shall transmit in addition to the D -M2 signal a single continuous - wave interferer with an equivalent frequency change rate not exceeding the values given in table 19.

Table 19: Frequency change rate

Equipment type	Frequency change rate
A-field only	1 MHz/s
half-slot	2,5 MHz/s
full-slot	10 MHz/s
Variable length slot with $j = 640$	20 MHz/s
double-slot	20 MHz/s

- The frequency (f) and levels are determined by table 20. If discrete frequency steps are used, the step shall not exceed 1 MHz.

- The EUT shall operate on the declared frequency allocation with the low band edge F_L in MHz and the high band edge F_U in MHz.

Table 20: Interferer levels

Frequency (f)	Continuous wave interferer level (dBm)
$25 \text{ MHz} \leq f < F_L - 100 \text{ MHz}$	-23
$F_L - 100 \text{ MHz} \leq f < F_L - 5 \text{ MHz}$	-33
$ f - F_c > 6 \text{ MHz}$	-43
$F_U + 5 \text{ MHz} < f \leq F_U + 100 \text{ MHz}$	-33
$F_U + 100 \text{ MHz} < f \leq 12,75 \text{ GHz}$	-23

- For the basic DECT frequency band allocation F_L is 1 880 MHz and F_U is 1 900 MHz. EUTs may support additional carriers, e.g. up to $F_U = 1 920$ MHz.
- g) The LT shall for frequencies and conditions defined under step f) monitor bit errors with time intervals not exceeding 1 s.
- h) At frequencies where 1 or more errors are found, the LT shall calculate the BER of the EUT as determined in clause 5.1.12.4 and annex D. Values in annex E can be used for BER calculations within the LT, when loss of synchronization is detected. If the measured BER exceeds 0,001 the frequency shall be recorded.
- i) For all frequencies recorded under h) the measurement and recording procedure shall be repeated, but with the interferer level decreased to -43 dBm.
- j) For all frequencies recorded under i), the measurement and recording procedure shall be repeated, but with the interferer level decreased to -63 dBm.

5.3.7.4.3 Verdict criteria

A spurious response frequency is defined as the nominal DECT carrier frequency F_g closest to a frequency recorded under step h) of clause 5.3.7.4.2.

NOTE: F_g is defined in ETSI EN 300 175-2 [1], clause 4.1.1 as the nominal DECT RF carrier whose centre frequency is generated by the formula:

- $F_g = F_0 - g \times 1\,728 \text{ kHz}$;
- where $F_0 = 1\,897,344 \text{ MHz}$ and g is any integer.

An occurrence is defined as a group of up to 3 spurious response frequencies with consecutive values of g . Two occurrences are defined as separate if between these occurrences there is at least one nominal DECT carrier frequency that is not a spurious response frequency.

Every recorded frequency is defined to be related to the closest spurious response frequency.

Every recorded frequency is defined to be related to the occurrence which contains the related spurious response frequency.

All frequencies recorded under step h) of clause 5.3.7.4.2 shall only relate to a maximum of 8 separated occurrences.

All frequencies recorded under step i) of clause 5.3.7.4.2 shall only relate to a maximum of 4 separated occurrences.

No frequency shall have been recorded under step j) of clause 5.3.7.4.2.

The results obtained shall be compared to the limits in clause 4.5.7.4 in order to prove compliance with the requirement.

5.3.7.5 Radio receiver blocking case 2: owing to signals occurring at a different time

5.3.7.5.1 Test environment

The test shall take place at a test site or using a test fixture for equipment with integral antenna.

If the EUT has an antenna connector then it shall be used to connect the EUT to the LT.

The test shall take place under nominal supply voltage conditions and at a nominal temperature.

5.3.7.5.2 Method of measurement

- a) The EUT shall be orientated in the reference position as determined in clause 5.1.12.3 if no antenna connector is available.
- b) The LT shall be programmed to set its RF transmission to a power level of -73 dBm at the input of the EUT receiver.
- c) The LT shall place the EUT in a mode whereby the EUT is positioned in RF channel $c = 5$ and slot-pair N (i.e. slot N and slot $N + 12$ with $N \geq 2$). If so equipped, the handover function in the EUT shall be disabled (see clause 5.1.10.3 for the appropriate test message reference).
- d) The EUT shall be placed in a test mode whereby it performs the loopback function as referenced in clause 5.1.10.3.
- e) A test modulation signal D-M2 (see clause 5.1.9.8) is generated by the LT.
- f) The LT shall transmit at the same time a DECT-like physical packet interferer at a level of -14 dBm in slot $N - 2$ for measuring a PT and slot $(N + 12) - 2$ for measuring an FT (see clause 5.1.9.5 for a description of this interferer).

The power level of any emissions by the LT shall be less than -93 dBm on slot $N - 1$ for measuring a PT and on slot $(N + 12) - 1$ for measuring an FT.

- g) The LT shall be programmed to set its RF transmission to a power level of -83 dBm at the input of the EUT receiver in slot N for measuring a PT and in slot $N + 12$ for measuring an FT.
- h) The LT shall calculate the BER of the EUT as determined in clause 5.1.12.4 and annex D. Values in annex E can be used for BER calculations within the LT, when loss of synchronization is detected.
- i) Steps b) to h) shall be repeated with the EUTs receiver placed on RF channels $c = 0$ and 9.

5.3.7.5.3 Verdict criteria

The results obtained shall be compared to the limits in clause 4.5.7.5.2 in order to prove compliance with the requirement.

5.3.7.6 Receiver intermodulation performance

5.3.7.6.1 Test environment

The test should preferably take place at a test site, otherwise a test fixture shall be used.

If the EUT has an antenna connector then it shall be used to connect the EUT to the LT.

The test shall take place under nominal supply voltage conditions and at a nominal temperature.

5.3.7.6.2 Method of measurement

- a) The EUT shall be oriented in the reference position as determined in clause 5.1.12.3 if no antenna connector is available.
- b) The LT shall be programmed to set its RF transmission level to a power level of -80 dBm at the input of the EUT receiver.
- c) The EUT's RF channel is recorded as channel "M".
- d) The LT shall place the EUT in a mode whereby the EUT is positioned in a LT specified slot and frequency. If so equipped, the handover function in the EUT shall be disabled (see clause 5.1.10.3 for the appropriate test message reference).
- e) The EUT shall be placed in a test mode whereby it performs the loopback function as referenced in clause 5.1.10.3.
- f) A test modulation signal D - M2 (see clause 5.1.9.8) is generated by the LT.
- g) The LT shall then transmit in addition to the D - M2 test signal, a modulated DECT-like carrier "B" and a continuous-wave carrier "A" whose intermodulation product is present within the DECT channel "M" of the EUT. The level of these carriers shall be set to -48 dBm at the receiver input of the EUT. The LT shall calculate the BER of the EUT as determined in clause 5.1.12.4 and annex D. Values in annex E can be used for BER calculations within the LT, when loss of synchronization is detected. The measurement shall be performed 4 times with the interfering carriers and the EUT receive channel positioned on the DECT RF channels as given in table 21.

Table 21: RF carrier combinations

M	A	B
5	7	9
5	3	1
0	2	4
9	7	5

5.3.7.6.3 Verdict criteria

The results obtained shall be compared to the limits in clause 4.5.7.6.2 in order to prove compliance with the requirement.

5.3.7.7 Spurious emissions when the PP has no allocated transmit channel

5.3.7.7.1 Test environment

The test shall take place at a test site.

Connection between the EUT and the LT shall be made by means of a test antenna.

The test shall take place under nominal supply voltage conditions and at a nominal temperature.

5.3.7.7.2 Method of measurement

- a) The analyser controls shall be set to the following:
 - frequency span: as required for frequency range;
 - resolution bandwidth: 1 MHz (in DECT band) 100 kHz (outside DECT band);
 - video bandwidth: greater than resolution bandwidth;
 - averaging: none;
 - peak hold: on;

- filtering type: synchronously tuned for measurements in the DECT band.
- b) The EUT shall be oriented in the reference position as determined in clause 5.1.12.3.
- c) The EUT shall be placed into a receive or idle mode for the duration of this test.
- d) The test shall be carried out across the RF range of 30 MHz to 4 GHz and the power measurements shall be performed using the resolution bandwidths as indicated in a).

5.3.7.7.3 Verdict criteria (outside the DECT band)

The results obtained shall be compared to the limits in clause 4.5.7.7.2.1 in order to prove compliance with the requirement.

5.3.7.7.4 Verdict criteria (inside the DECT band)

The results obtained shall be compared to the limits in clause 4.5.7.7.2.2 in order to prove compliance with the requirement.

5.3.8 Channel access

5.3.8.1 Test Environment

The test shall take place under nominal temperature conditions and at a nominal supply voltage.

No special test equipment is required to emulate a PT or an FT i.e. no Lower Tester (LT) is required.

The EUT shall be capable of connecting to test measurement equipment via an antenna connector. Ensure the PT or FT is capable of powering up in normal operational mode i.e. it will not power up in any special test mode.

During PT testing a vendor specific "Golden" FT will be used as a reference when testing the PT. This "Golden" FT could be the FT EUT described in the tests below. In this case the "Golden" FT shall be registered/paired to the PT EUT.

NOTE: "Golden unit" (FT or PT) in the context of the present document means a device compliant to the present document, that is not the EUT for a given test, and that implements the opposite side radio termination (FT when the EUT is a PT, PT when the EUT is a FT). The "Golden unit" does not need to be a special device and can be supplied by the vendor of the EUT. The only requirement is that it should also conform to the present document. The terms "corresponding device" and "companion device" are also used in other standards and technical documents with equivalent meaning.

For ULE testing of channel selection on the PT side, both PT and FT will be EUTs, i.e. channel selection depends on both sides to make the decision.

Test measurement equipment consists of a signal generator, a spectrum analyser and a splitter/combiner to realize all the test scenarios detailed below.

All the channel measurement tests detailed within this clause require access on both PT and FT, to an antenna connector to allow connection of coaxial cables between the endpoints.

5.3.8.2 FT Test Setup

5.3.8.2.1 General

- a) Ensure the FT EUT is powered off.
- b) Attach the FT EUT, RF Signal generator and spectrum analyser to unique ports of an RF switch unit (see figure 39) ensuring the attenuation on all ports is the same.
- c) Switch on the spectrum analyser and ensure the power levels on all the carriers under test can be measured.

- d) Switch on the RF signal generator and apply an interference pattern across all the carriers under test except the highest carrier and all the slots, so that a value of -70 dBm can be measured on the spectrum analyser, as confirmation that the FT EUT will also receive this value. Fine tuning to receive this value at the EUT can be achieved by either attaching external attenuators or adjusting the signal generator power sweep intensity.

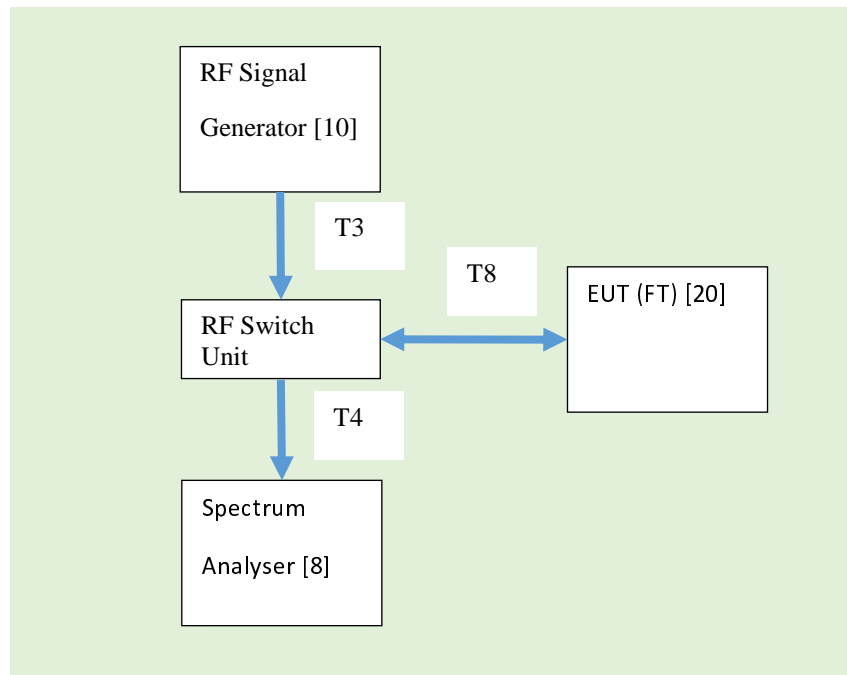

Figure 39: FT Test Setup

5.3.8.2.2 FT Method of Measurement

- On the spectrum analyser ensure that all the carriers except the highest have a -70 dBm signal.
- Power on the FT EUT and on the spectrum analyser monitor the presence of a signal now on the highest carrier. This will indicate that a dummy bearer is present. Switch off the FT EUT and ensure it disappears.
- Repeat similar steps to a) and b) above, but this time first apply the interferer pattern across all the carriers, except the lowest carrier and this time confirm the dummy bearer is now on lowest carrier.

5.3.8.2.3 FT Verdict Criteria

The presence of the dummy bearer shall be confirmed on the least interfered carrier using the spectrum analyser, and it shall be permitted on any slot(s) within this carrier. When the EUT is powered up, its presence shall be detected by an increase in power level and when powered off, this signal shall disappear.

5.3.8.3 PT Test Setup

5.3.8.3.1 General

- Ensure the FT "Golden" unit and the PT EUT are powered off. In the case of ULE, the FT "Golden Unit" shall be replaced by an FT EUT, as the channel selection on the PT relies on information supplied by the FT, so both sides are EUTs in this respect.
- Attach the FT "Golden" unit, the PT EUT, the Signal generator and spectrum analyser to unique ports of an RF switch unit (see figure 40), ensuring the attenuation on all ports is the same.
- Switch on the spectrum analyser and ensure the power levels on all the carriers under test can be measured.

- d) Switch on the RF Signal generator and apply an interference pattern across all the carriers under test except the highest carrier and all the slots, so that a value of -70 dBm can be measured on the spectrum analyser, as confirmation that the PT EUT and FT "Golden" unit will also receive this value. Fine tuning to receive this value at the EUT can be achieved by either attaching external attenuators or adjusting the signal generator power sweep intensity.

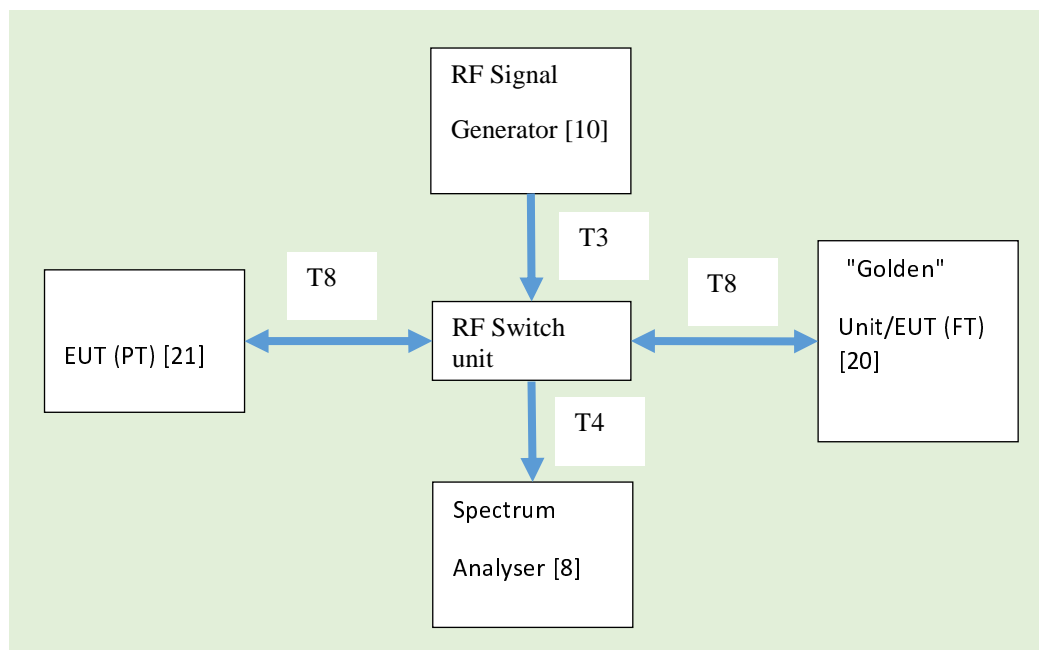

Figure 40: PT Test Setup

5.3.8.3.2 PT Method of Measurement

- On the spectrum analyser ensure that all the carriers except the highest have a -70 dBm signal.
- Power on the FT "Golden" unit and on the spectrum analyser monitor the presence of a signal now on the least interfered carrier and on any time slot(s). This will indicate the presence of the dummy bearer.
- Now power on the PT EUT and ensure it sets up a traffic bearer in its normal mode of operation, this will be observed on the spectrum analyser by the presence of additional signal(s) in the time domain and on the least interfered carrier to the one created by the dummy bearer in the previous step.
- Now power off first the PT EUT and then the FT "Golden" unit and observe the disappearance of the signals on the highest carrier, then repeat steps b) and c) above, but first apply the interferer pattern across all the carriers except the lowest and this time confirm the dummy bearer and the traffic bearer are now on lowest carrier.

5.3.8.3.3 PT Verdict Criteria

The presence of the dummy bearer and traffic bearer/s shall be confirmed on the least interfered carrier using the spectrum analyser, where each bearer will have a unique time slot where the increased power level can be seen. When the FT "Golden" unit and the PT EUT is powered up, its presence shall be detected by an increase in power level(s) and when powered off, this signal shall disappear.

5.3.8.4 Channel Release

5.3.8.4.1 General

- Ensure that the following items of equipment are available:
 - PT EUT

- 2) PT "Golden Unit"
 - 3) FT EUT
 - 4) FT "Golden Unit"
 - 5) RF Switch Unit
 - 6) Spectrum analyser
- b) Initially configure the PT EUT and the FT "Golden Unit" as shown in figure 41.
 - c) Switch on the spectrum analyser and ensure the power levels on all the carriers under test can be measured.

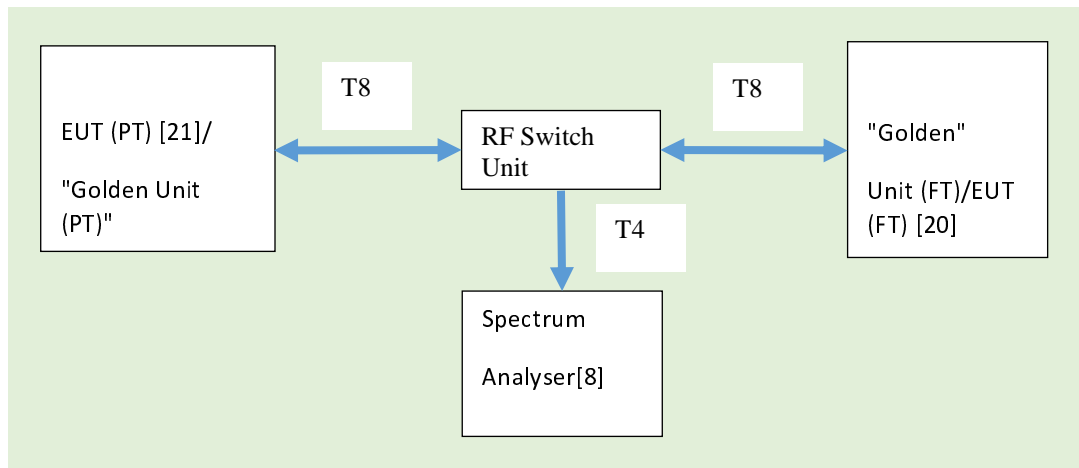

Figure 41: Channel Release Test Setup

5.3.8.4.2 Method of Measurement

- a) Attach an FT "Golden Unit", PT EUT and spectrum analyser to the splitter as shown in figure 41, ensuring both FT and PT are powered off initially.
- b) Power on the FT "Golden" unit and on the spectrum analyser monitor the presence of a signal, this represents the Dummy Bearer.
- c) Power on the PT and ensure a connection is established by monitoring the presence of a new signal representing the connection.
- d) Now power off the FT "Golden Unit" and ensure the signal/s representing the connection disappear within 10 seconds.
- e) Now replace the FT "Golden Unit" with an FT EUT, and replace the PT EUT with a PT "Golden Unit" and create a connection again using the general strategy described in the previous steps.
- f) Now power off the PT "Golden Unit" and ensure the signal representing the connection disappears within 10 seconds. However, the signal representing the Dummy Bearer should remain.

5.3.8.4.3 Channel Release Verdict Criteria

The spectrum analyser shall be used to ensure that in both channel release scenarios, (FT powering off and then PT powering off) that a connection between the PT and FT is released within 10 seconds.

5.3.9 WRS testing

5.3.9.0 General

The WRS EUT shall be tested as described below.

A WRS requires to be synchronized to a dummy bearer to derive its reference timer for PT and FT transmissions.

5.3.9.1 Testing as a PP

The WRS shall operate as a PP in Test Standby Mode (TSM), as a stand alone module.

In this mode it shall be tested as a normal PP with the exception that RFP class E2 test conditions, see clause 5.1.15, shall be used if it is intended for outdoor use, and that test case 19 is not applicable. See figure 42.

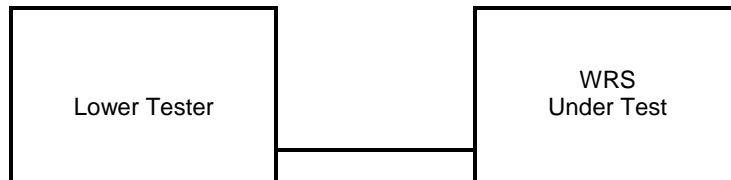

Figure 42: WRS testing as a PP

5.3.9.2 Testing as an RFP

A dummy bearer shall be generated by the Lower Tester or (if that is not possible) by an RFP supplied by the manufacturer and conforming to the present document. The WRS EUT shall be synchronized to the dummy bearer and shall operate as an RFP in Test Standby Mode (TSM). The dummy bearer may change bearer during the test.

The EUT shall tested as an RFP as regards the carrier frequency demands of clause 5.3.1 and reference timer accuracy demands of clause 5.3.2.2. See figure 43.

NOTE: The power combiner is not needed if the PP and RFP functions have different antenna connectors.

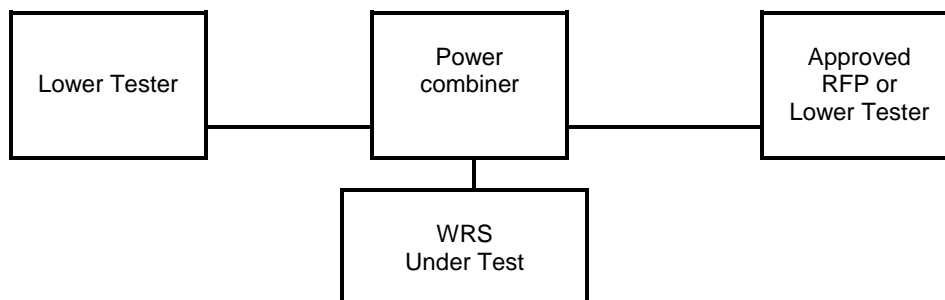

Figure 43: WRS testing as an RFP

5.3.9.3 Additional requirements

There are no defined tests for the Additional requirements of clause 4.5.9.3 of the present document. Conformance to the requirements shall be shown by verifying that:

- The WRS provides a mechanism to control the number of multihops, see ETSI EN 300 700 [5], clause 7.4.5.
- The WRS applies the defined frame multiplexing structure, see ETSI EN 300 700 [5], clause 7.4.6.
- The REP conforms to the requirements for channel selection of double duplex bearers, see ETSI EN 300 700 [5], clause 7.4.2.

5.3.10 Requirements for PPs with direct PP to PP communication mode

5.3.10.0 General

PPs or CTAs with direct communication mode option shall be tested for the PP requirements of the present document for normal non-direct communication with the amendments defined in ETSI EN 300 175-3 [2], clause G.2.1 and clause G.2.2.

5.3.11 Distributed Communications

5.3.11.0 General

PPs and CTAs with distributed communications option, HyPs, shall be tested as a stand alone PP and shall comply with all relevant PP test cases in the present document. In addition the HyPs shall be tested as an RFP as regards the carrier frequency demands of clause 4.5.1 and reference timer accuracy demands of clause 4.5.2 of the present document.

The HyP EUT shall meet the PT and FT requirements as described below.

A HyP requires to be synchronized to a bearer to derive its reference timer for PT and FT transmissions.

5.3.11.1 Testing as a PP

The EUT shall operate as a PP in Test Standby Mode (TSM) as a stand alone module.

In this mode it shall be tested as a normal PP. See figure 44.

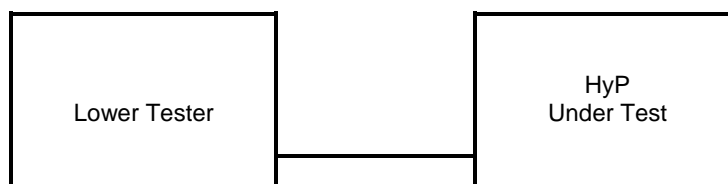

Figure 44: HyP testing as a PP

5.3.11.2 Testing as an RFP

A dummy bearer shall be generated by the Lower Tester or (if that is not possible) by an RFP supplied by the manufacturer and conforms to the present document. The EUT shall be synchronized to the dummy bearer and shall operate as an RFP in Test Standby Mode (TSM). The dummy bearer may change bearer during the test.

The EUT shall be tested as an RFP as regards the carrier frequency demands of clause 5.3.1 and reference timer accuracy demands of clause 5.3.2.2. See figure 45.

NOTE: The power combiner is not needed if the PP and RFP functions have different antenna connectors.

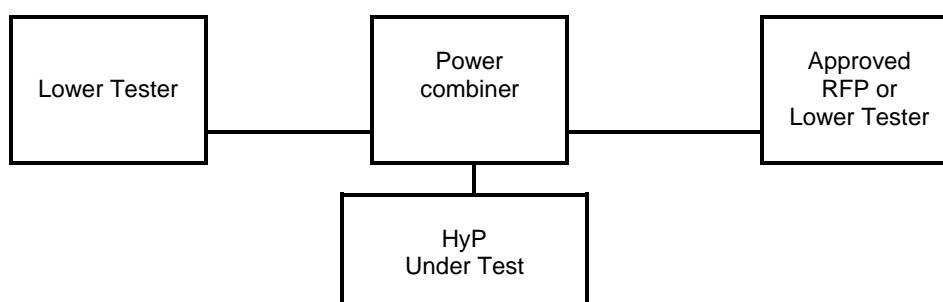

Figure 45: HyP testing as an RFP

5.3.11.3 Conformance

The equipment is to conform to the tests described in clauses 5.3.1, 5.3.2, 5.3.3, 5.3.4, 5.3.5, 5.3.6, 5.3.7 and 5.3.8 of the present document applied accordingly to the FT and PT behaviours.

5.3.12 Higher level modulation options

5.3.12.1 General

The higher level modulation options are described in clause 4.5.12 of the present document.

5.3.12.2 Activation of higher level modulations when EUT is in Test Standby Mode

The manufacturer shall supply a method, to be applied when the EUT is in Test Standby Mode, by which the EUT supporting 4/8/16/64-level modulation might activate such options. For the options supported, it shall be possible to select each modulation option independently of the other.

Such a method may be controlled either by some means of manual switching (e.g. dip-switch, jumper, prom, or key-pad code as designated by the manufacturer), or by means of the CHANGE_MODULATION_SCHEME test message, if agreed with the test house. If only one type of higher level modulation is supported, the method may consist of activating this higher level modulation option at the expiring of a pre-defined timer started after the bearer setup.

The manufacturer shall describe this method in the manufacturer's declaration (see clause 4.3).

For the purpose of testing (especially when in Test Standby Mode) the EUT shall always use 2-level modulation in the A-field.

Annex A (informative): Relationship between the present document and the essential requirements of Directive 2014/53/EU

The present document has been prepared under the Commission's standardisation request C(2015) 5376 final [i.9] to provide one voluntary means of conforming to the essential requirements of Directive 2014/53/EU on the harmonisation of the laws of the Member States relating to the making available on the market of radio equipment and repealing Directive 1999/5/EC [i.10].

Once the present document is cited in the Official Journal of the European Union under that Directive, compliance with the normative clauses of the present document given in table A.1 confers, within the limits of the scope of the present document, a presumption of conformity with the corresponding essential requirements of that Directive and associated EFTA regulations.

**Table A.1: Relationship between the present document
and the essential requirements of Directive 2014/53/EU**

Harmonised Standard ETSI EN 301 406					
Requirement				Requirement Conditionality	
No	Description	Essential requirements of Directive	Clause(s) of the present document	U/C	Condition
1	Accuracy and stability of RF carriers	3.2	4.5.1	U	
2	Accuracy and stability of timing parameters	3.2	4.5.2	U	
3	Reference timing accuracy of a RFP	3.2	4.5.2	U	
4	Measurement of packet timing accuracy	3.2	4.5.2	U	
5	Transmission burst	3.2	4.5.3	U	
6	Transmitted power: PP and RFP with an integral antenna	3.2	4.5.4.1.1	C	If equipment incorporates an integral antenna
7	Transmitted power: PP and RFP with external connections for all antennas	3.2	4.5.4.1.2	C	If equipment provides an external antenna connector
8	Transmitted power: PP and RFP with both integral and external antennas	3.2	4.5.4.1.3	C	If equipment provides an integral antenna and an external antenna connector
9	RF carrier modulation	3.2	4.5.5	U	
10	Emissions due to modulation	3.2	4.5.6.2	U	
11	Emissions due to transmitter transients	3.2	4.5.6.3	U	
12	Emissions due to intermodulation	3.2	4.5.6.4	U	
13	Spurious emissions when allocated a transmit channel	3.2	4.5.6.5	U	
14	Radio receiver sensitivity	3.2	4.5.7.1	U	
15	Radio receiver reference BER and FER	3.2	4.5.7.2	U	
16	Radio receiver interference performance	3.2	4.5.7.3	U	
17	Radio receiver blocking case 1	3.2	4.5.7.4	U	
18	Radio receiver blocking case 2	3.2	4.5.7.5	U	
19	Receiver intermodulation performance	3.2	4.5.7.6	U	
20	Spurious emissions when the PP has no allocated transmit channel	3.2	4.5.7.7	U	
21	Channel access	3.2	4.5.8	U	
22	WRS testing	3.2	4.5.9	C	If equipment is a WRS
23	Requirements for PPs with direct PP to PP communication mode	3.2	4.5.10	C	If equipment implements PP to PP communication
24	Direct Communication	3.2	4.5.11	C	If equipment implements Direct communication
25	Higher level modulation options	3.2	4.5.12	C	If equipment implements Higher level modulation

Key to columns:**Requirement:**

No A unique identifier for one row of the table which may be used to identify a requirement.

Description A textual reference to the requirement.

Essential requirements of Directive

Identification of article(s) defining the requirement in the Directive.

Clause(s) of the present document

Identification of clause(s) defining the requirement in the present document unless another document is referenced explicitly.

Requirement Conditionality:

U/C Indicates whether the requirement is unconditionally applicable (U) or is conditional upon the manufacturers claimed functionality of the equipment (C).

Condition Explains the conditions when the requirement is or is not applicable for a requirement which is classified "conditional".

Presumption of conformity stays valid only as long as a reference to the present document is maintained in the list published in the Official Journal of the European Union. Users of the present document should consult frequently the latest list published in the Official Journal of the European Union.

Other Union legislation may be applicable to the product(s) falling within the scope of the present document.

Annex B (informative): Procedures for test fixture calibration and for measurement of radiated spurious emissions

B.1 Calibration of test fixture for receiver measurements

B.1.0 Procedure

The calibration procedure utilizes the average measured usable sensitivity of the receiver. The average measured usable sensitivity expressed as signal level for bit stream should be the average of eight measurements of signal level, expressed in dBm, at the nominal frequency of the receiver and with specified test modulation which produces after demodulation a data signal with a bit error ratio of 10^{-3} , when the receiver is rotated in 45° increments, starting at the reference orientation.

B.1.1 Method of measurement

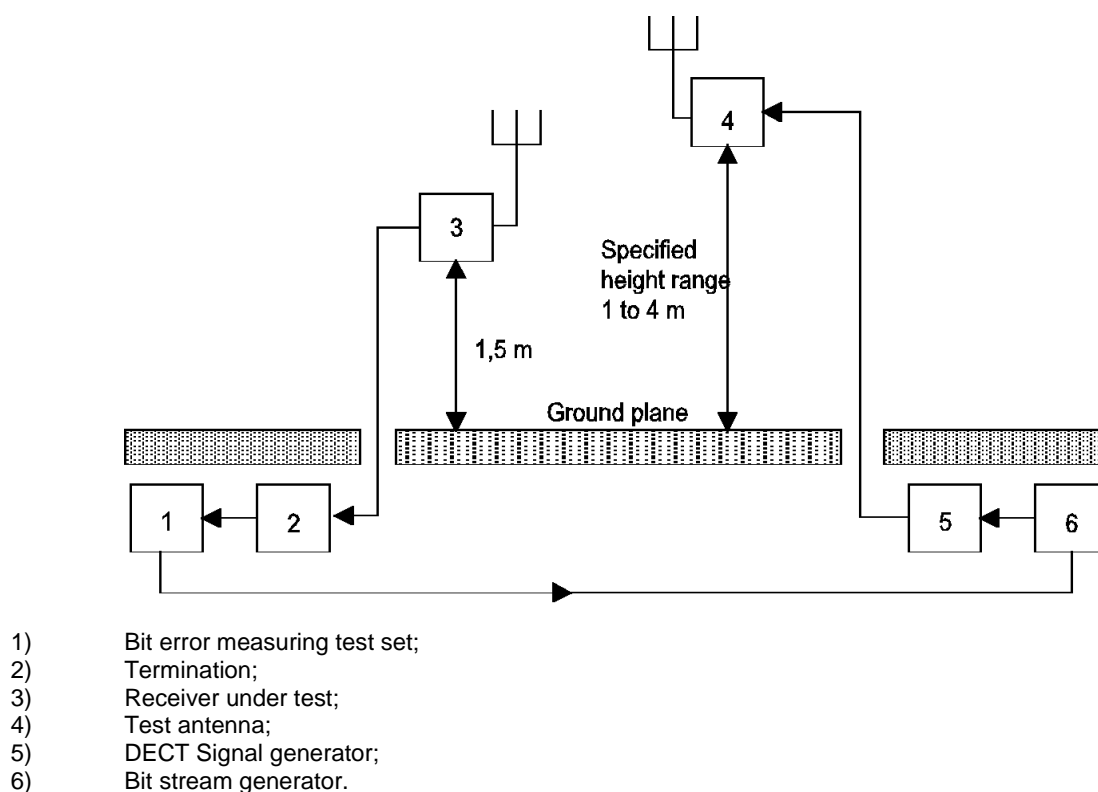

Figure B.1: Measurement arrangement No.1

- a) A test site which fulfils the requirements of the specified frequency range of this measurement should be used. The test antenna should be oriented initially for vertical polarization unless otherwise stated.

A signal generator capable of producing a DECT signal should be connected to the test antenna. The signal generator should be at the nominal frequency of the receiver and should be modulated by the test modulation D-M2. The receiver under test should be placed on the support in its standard position and oriented so that a face, specified by the manufacturer, is normal to the direction of the test antenna. This is the reference orientation for the measurement.

- b) The bit pattern of the modulating signal should be compared to the bit pattern obtained from the receiver after demodulation.
- c) The output level of the signal generator should be adjusted until a bit error ratio of 10^{-3} is obtained.
- d) The test antenna should be raised or lowered again through the specified height range to find the lowest level of the test signal which produces the same bit error ratio.
- e) Record the minimum signal generator level from c) or d).
- f) Steps b) to e) should be repeated for the eight positions 45° apart of the receiver and the corresponding values of the generator output which produces the same bit error ratio will be determined and recorded.
- g) Using the calibration of the test site, calculate the eight signal levels X_i (dBm) corresponding to the output level above of the signal generator. The average measured usable sensitivity expressed as signal level X_{mean} (dBm) is given by:

$$X_{\text{mean}} = 20 \log \left[\frac{8}{\sum_{i=1}^{i=8} \left(\frac{1}{X_i^2} \right)} \right]^{1/2}$$

- h) Measurements b) to g) should be repeated with the test antenna oriented in horizontal polarization.
- i) Record the lower value of the two recorded in steps g) and h) above.
- j) Using the test fixture in measuring arrangement No.2 the measurement may also be performed under extreme test conditions.

Additional uncertainties can occur under extreme test conditions due to the calibration of the test fixture.

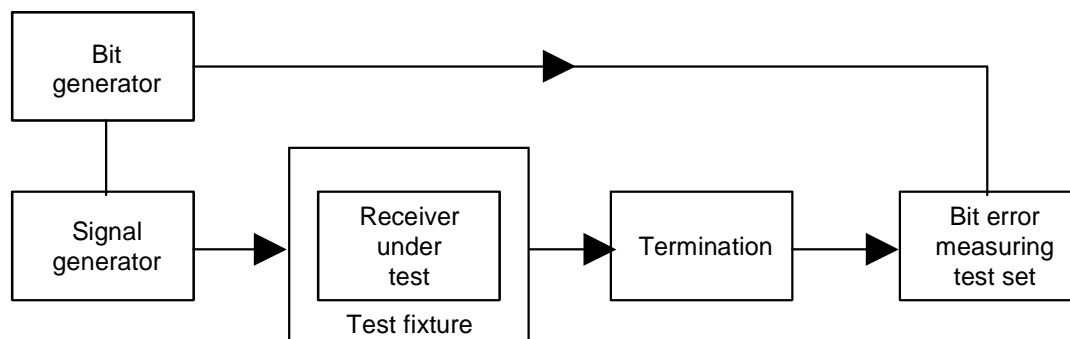

Figure B.2: Measurement arrangement No.2

- k) The test signal input level providing a BER of 10^{-3} should be determined under normal and extreme test conditions and the difference in dB is noted. This difference should be algebraically added to the average measured usable sensitivity to radiated fields for bit stream expressed in dBm under normal test conditions, to obtain the same quantity under extreme test conditions.

B.2 Radiated measurements

B.2.1 General

This clause contains all methods of measurements involving the absolute measurement of a radiated field. This field may be radiated by an integral antenna and/or by the cabinet of the equipment itself.

The standard test site should be a calibrated open-air test site, whose dimensions are appropriate to the frequency range of measurements.

In some cases operating on a test site may produce electromagnetic perturbation or, conversely, external radiation may disturb the measurement. For these reasons, and also in order to reduce the space required, other arrangements may be used, such as:

- stripline arrangements;
- anechoic chamber;
- indoors test site.

The methods of measurement described in this annex are based on an open-air test site, unless otherwise stated. If a stripline arrangement, an anechoic chamber or indoor test sites are used, the changes which apply to the method of measurement are indicated in their corresponding descriptions. For each radiated measurement, the nature and the dimensions of the test arrangement used should be recorded in the test report.

For extreme test conditions a test fixture should also be required.

For equipment normally operated from internal batteries it may be necessary to operate it from an external power source. A RF filter may be required to avoid radiation to or from the power leads.

B.2.2 Radiated spurious emissions

B.2.2.1 Definition

Spurious emissions are emissions at frequencies, other than those of the carrier and sidebands associated with normal modulation, radiated by the antenna and by the cabinet of the transmitter.

They are specified as the radiated power of any discrete signal.

B.2.2.2 Method of measurement

This method of measurement applies to transmitters having an integral antenna.

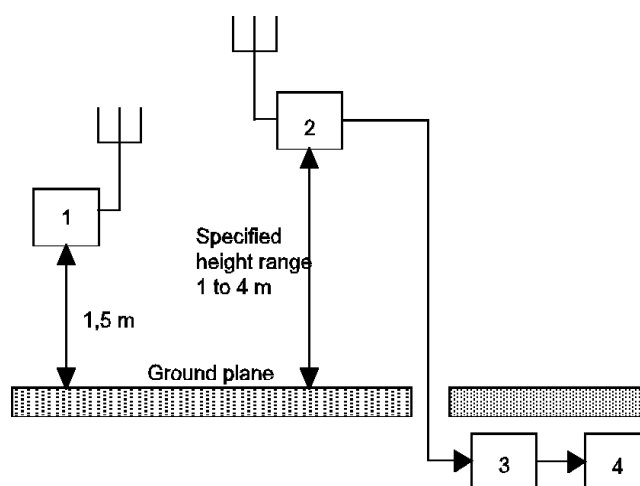

- 1) Transmitter under test;
- 2) Test antenna;
- 3) High "Q" (notch) or high pass filter;
- 4) Spectrum analyser or selective voltmeter.

Figure B.3: Measurement arrangement No.1

- a) A test site which fulfils the requirements of the specified frequency range of this measurement should be used. The test antenna should be oriented initially for vertical polarization and connected to a spectrum analyser or a selective voltmeter, through a suitable filter to avoid overloading of the spectrum analyser or selective voltmeter. The bandwidth of the spectrum analyser is set to a suitable value to correctly perform the measurement.

For the measurement of spurious emissions below the second harmonic of the carrier frequency the filter used should be a high "Q" (notch) filter centered on the transmitter carrier frequency and attenuating this signal by at least 30 dB.

For the measurement of spurious emissions at and above the second harmonic of the carrier frequency the filter used should be a high pass filter with a stop band rejection exceeding 40 dB. The cut-off frequency of the high pass filter should be approximately 1,5 times the transmitter carrier frequency.

The transmitter under test should be placed on the support in its standard position and should be switched on.

- b) The radiation of any spurious emission should be detected by the test antenna and spectrum analyser or selective voltmeter over the specified frequency range, except for the channel on which the transmitter is intended to operate and its adjacent channels. The frequency of each spurious emission detected should be recorded. If the test site is disturbed by interference coming from outside, this qualitative search may be performed in a screened room, with a reduced distance between the transmitter and the test antenna.
- c) For each frequency at which an emission has been detected, the spectrum analyser or selective voltmeter should be tuned and the test antenna should be raised or lowered through the specified height range until a maximum signal level is detected on the spectrum analyser or selective voltmeter.
- d) The transmitter should be rotated through 360° about a vertical axis, until the maximum signal is received.
- e) The test antenna should be raised or lowered again through the specified height range until the maximum is obtained. This level should be recorded.

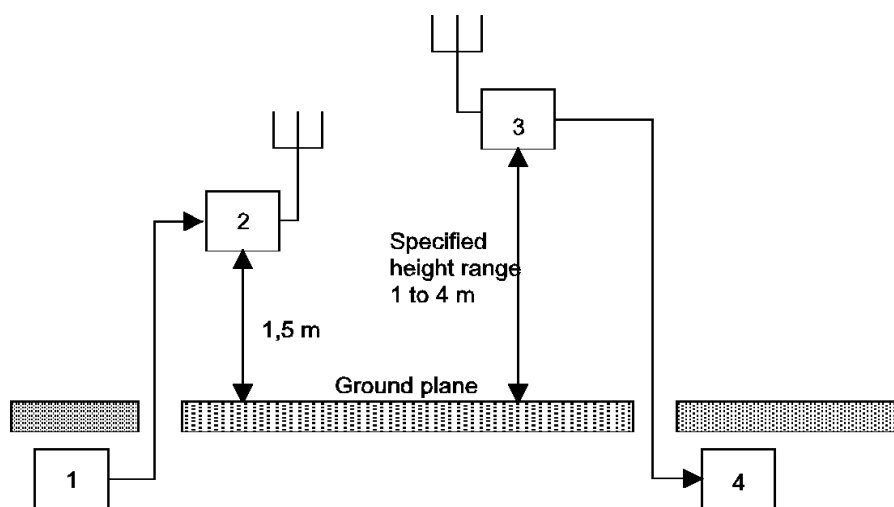

- 1) Signal generator;
 2) Substitution antenna;
 3) Test antenna;
 4) Spectrum analyser or selective voltmeter.

Figure B.4: Measurement arrangement No.2

- f) Using measurement arrangement No.2 the substitution antenna should replace the transmitter antenna in the same position and in vertical polarization. It should be connected to the signal generator.
- g) For each frequency at which an emission has been detected, the signal generator, substitution antenna, and spectrum analyser or selective voltmeter should be tuned. The test antenna should be raised or lowered through the specified height range until the maximum signal level is detected on the spectrum analyser or selective voltmeter. The level of the signal generator should be adjusted giving the same signal level on the spectrum analyser or selective voltmeter as in e) and this level should be recorded.

This value, after corrections due to the gain of the substitution antenna, referred to a resonant half wavelength dipole below 1 GHz or to an isotropic radiator above 1 GHz and the cable loss between the signal generator and the substitution antenna, is the radiated spurious emission level of this frequency.

- h) Steps c) to g) should be repeated with the test antenna oriented in horizontal polarization.
- i) Steps c) to h) should be repeated with the transmitter in stand-by condition if this option is available.

B.2.3 Cabinet radiation

B.2.3.1 Definition

Cabinet radiation is radiation at frequencies, excluding the band containing the carrier and sidebands associated with normal modulation, coming from the cabinet of the transmitter.

It is specified as the radiated power of any discrete signal.

B.2.3.2 Method of measurement

This method of measurement applies to transmitters having an antenna socket.

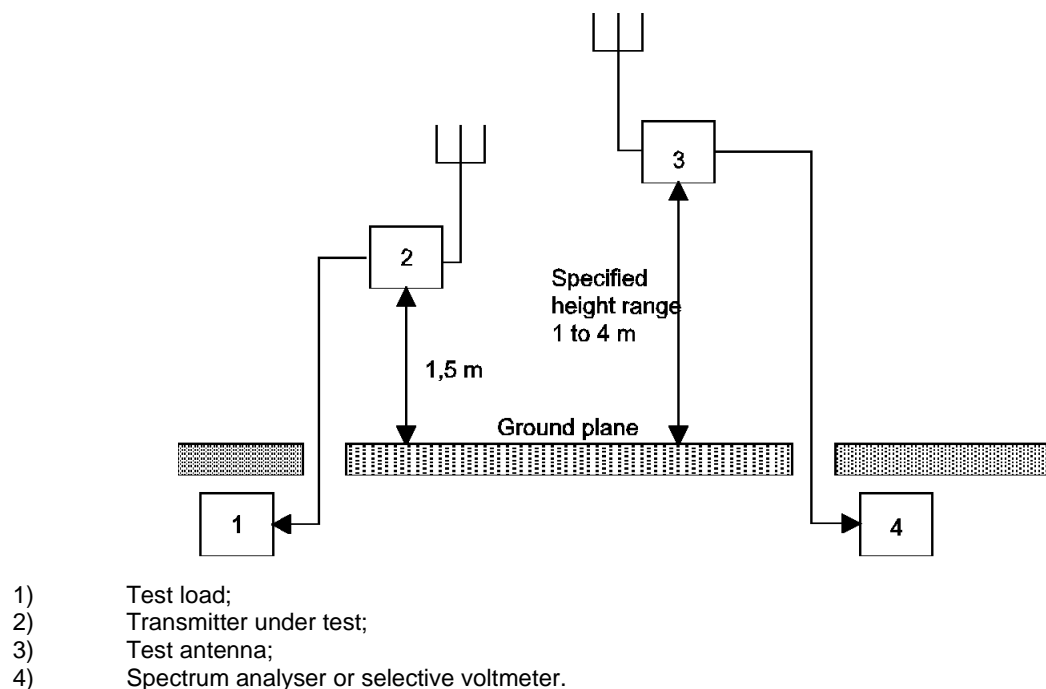

Figure B.5: Measurement arrangement No.1

- a) A test site which fulfils the requirements of the specified frequency range of this measurement should be used. The test antenna should be oriented initially for vertical polarization and connected to a spectrum analyser or selective voltmeter. The bandwidth of the spectrum analyser or selective voltmeter should be between 10 kHz and 100 kHz, set to a suitable value to correctly perform the measurement.

The transmitter under test should be placed on the support in its standard position, connected to a test load and switched on.

- b) The same method of measurement as in b) to i) of clause B.2.2 should be used.

Annex C (informative): Procedure for measurement of conducted spurious emissions

C.1 Conducted spurious emissions

C.1.1 Definition

Conducted spurious emissions are discrete signals whose power is conveyed by conduction to the test load at frequencies other than those of the carrier and sidebands resulting from the normal process of modulation.

They are specified as the power level of any discrete signal delivered into a test load.

C.1.2 Method of measurement

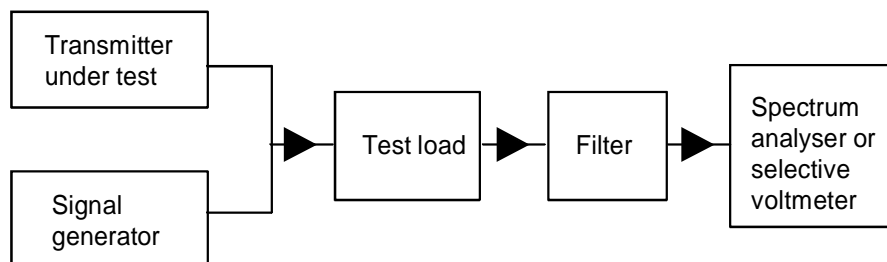

Figure C.1: Test set up

- a) The transmitter should be connected to a spectrum analyser or a selective voltmeter through a test load and an appropriate filter to avoid overloading of the spectrum analyser or selective voltmeter. See figure C.1. The bandwidth of the spectrum analyser or selective voltmeter should be between 10 kHz and 100 kHz. The equipment used should have sufficient dynamic range and sensitivity to achieve the required measurement accuracy at the specified limit:
 - For the measurement of spurious emissions below the second harmonic of the carrier frequency the filter used should be a high "Q" (notch) filter centered on the transmitter carrier frequency and attenuating this signal by at least 30 dB.
 - For the measurement of spurious emissions at and above the second harmonic of the carrier frequency the filter used should be a high pass filter with a stop band rejection exceeding 40 dB. The cut-off frequency of the high pass filter should be approximately 1,5 times the transmitter carrier frequency.
 - Precautions may be required to ensure that the test load does not generate or that the high pass filter does not attenuate, the harmonics of the carrier.
- b) The transmitter should be unmodulated and operating at the maximum limit of its specified power range.
- c) The frequency of the spectrum analyser or selective voltmeter should be adjusted over the specified frequency range. The frequency and level of every spurious emission found should be noted. The emissions within the channel occupied by the transmitter carrier and its adjacent channels should not be recorded.

- d) If the spectrum analyser or selective voltmeter has not been calibrated in terms of power level at the transmitter output, the level of any detected components should be determined by replacing the transmitter by the signal generator and adjusting it to reproduce the frequency and level of every spurious emission recorded in c).
- e) The absolute power level of each of the emissions noted should be measured and recorded.
- f) The measurement should be repeated with the transmitter in stand-by condition if this option is available.

Annex D (normative): Measurement of BER and FER

The LT shall use the following method for calculating BER:

- in frames counted for synchronization loss the bit errors for the frame shall be disregarded;
- only whole numbers of frames shall be tested;
- the threshold used in the EUT to detect synchronization shall be the same for BER measurements as for normal operation:
 - let the total number of frames transmitted by the LT be α ; and
 - let the number of frames counted with synchronization loss be β ; and
 - let the number of bits counted in error be γ ; and
 - let the number of bits in a frame be ξ ;

then:

$$\text{BER} = \frac{\gamma}{\xi \times (\alpha - \beta)}$$

$$\text{FER} = \frac{\beta}{\alpha}$$

Over the measurement, the FER shall be less than 5 %, except for the test in clause 5.3.7.2, where the FER shall be less than 0,05 %.

For the calculation of the BER the following number N of transmitted bits shall be used:

$$N = (320 + 2\,016 \times (1 - e^{-\text{BER1}/\text{BERL}}))/\text{BERL}$$

where:

BERL - Limit value of BER measurement (depending on test case).

BER1 - BER measured during the first 320 000 bits (for BERL = 0,001) or 32 000 000 bits (for BERL = 0,00001) respectively. If BER1 is greater than BERL then BER1 = BERL is used for the calculation.

Annex E (informative): Procedures for the measurement of synchronization loss at the EUT by the LT

E.1 Description

Clause 5.3.7 requires the synchronization loss to be measured within the LT. In order that this can be made possible this annex describes a method by which the EUT can inform the LT when a synchronization error has occurred.

E.2 Method

When a synchronization error occurs the EUT should either:

- 1) re-transmit the last received B-field; or
- 2) transmit all 0's in the B-field

of the transmit half frame immediately following the loss of synchronization.

The LT should detect the synchronization error by using a threshold method on the bit error count for the frame. If the BER calculated for the frame is less than 25 % then the BER calculated should go towards the total bit error count for the measurement. If the BER calculated is greater than or equal to 25 % then the frame is counted as a synchronization error and the total bit error count is not incremented.

Annex F (informative): Maximum measurement uncertainty

The measurements described in the present document are based on the following assumptions:

- the measured value related to the corresponding limit is used to decide whether an equipment meets the requirements of the present document;
- the value of the measurement uncertainty for the measurement of each parameter is included in the test report.

Table F.1 shows the recommended values for the maximum measurement uncertainty figures.

Table F.1: Maximum measurement uncertainty

Parameter	Uncertainty
Relative drift radio frequency	±1 kHz
Absolute radio frequency	±10 kHz
Conducted emissions	±1 dB
Radiated emissions	±3 dB
Absolute RF power (via an antenna connector)	±1 dB
Absolute RF power (for unwanted emissions in the DECT band)	±4 dB
Absolute RF power (for unwanted emissions outside the DECT band)	conducted: ±4 dB radiated: ±6 dB
Relative RF power	±1 dB
Absolute RF power (radiated)	±3 dB
Relative Packet timing	±0,1 µs
Absolute Packet timing	±1 µs
Timing stability of FT	1 ppm
Transmitter burst transient time	±20 % (of the measured value)
Peak frequency deviation	±10 kHz

Annex G (informative): Additional receiver parameters identified under article 3.2 of Directive 2014/53/EU

Table G.1 lists receiver parameters defined in ETSI EG 203 336 [i.13] under article 3.2 of Directive 2014/53/EU [i.10] but not implemented in the present document due to the stated reasons.

Table G.1: Non-implemented Receiver parameters

Receiver parameter	Comment
Receiver dynamic range	Dynamic range measurements implicitly covered due to selectivity tests specified within the present document.
Reciprocal mixing	Implicitly covered due to interference characteristics specified in terms of selectivity and/or blocking.

Table G.2 lists receiver parameters defined in ETSI EG 203 336 [i.13] under article 3.2 of Directive 2014/53/EU [i.10] implemented in the present document.

Table G.2: Implemented Receiver parameters

Receiver parameter	Comment
Receiver sensitivity	Covered in clause 4.5.7.1
Receiver co-channel rejection	Covered in clause 4.5.7.3
Receiver adjacent channel selectivity	Covered in clause 4.5.7.3
Receiver blocking	Covered in clauses 4.5.7.4 and 4.5.7.5
Receiver spurious response rejection	Covered in clause 4.5.7.4
Receiver radio-frequency intermodulation	Covered in clause 4.5.7.6
Receiver unwanted emissions in the spurious domain	Covered in clause 4.5.7.4

Annex H (informative): Bibliography

- Council Directive 89/336/EEC of 3 May 1989 on the approximation of the laws of the Member States relating to electromagnetic compatibility (EMC Directive).
- Council Directive 73/23/EEC of 19 February 1973 on the harmonization of the laws of Member States relating to electrical equipment designed for use within certain voltage limits (LV Directive).
- ETSI EN 301 908-10: "IMT cellular networks; Harmonised Standard for access to radio spectrum; Part 10: Base Stations (BS), Repeaters and User Equipment (UE) for IMT-2000 Third-Generation cellular networks".
- ETSI EN 301 406-2: "Digital Enhanced Cordless Telecommunications (DECT); Harmonised Standard for access to radio spectrum; Part 2: DECT-2020 NR".
- Recommendation ITU-T V.11 (1996): "Electrical characteristics for balanced double-current interchange circuits operating at data signalling rates up to 10 Mbit/s".
- ETSI EN 301 649: "Digital Enhanced Cordless Telecommunications (DECT); DECT Packet Radio Service (DPRS)".
- ETSI TS 102 527-1: "Digital Enhanced Cordless Telecommunications (DECT); New Generation DECT; Part 1: Wideband speech".
- ETSI TS 102 527-2: "Digital Enhanced Cordless Telecommunications (DECT); New Generation DECT; Part 2: Support of transparent IP packet data".
- ETSI TS 102 527-3: "Digital Enhanced Cordless Telecommunications (DECT); New Generation DECT; Part 3: Extended Wideband speech services".
- ETSI TS 102 527-4: "Digital Enhanced Cordless Telecommunications (DECT); New Generation DECT; Part 4: Light Data Services; Software Update Over The Air (SUOTA), content downloading and HTTP based applications".
- ETSI TS 102 527-5: "Digital Enhanced Cordless Telecommunications (DECT); New Generation DECT; Part 5: Additional feature set nr. 1 for Extended Wideband speech services".
- Recommendation ITU-T G.726 (1990): "40, 32, 24, 16 kbit/s adaptive differential pulse code modulation (ADPCM)".

Annex I (informative): Change History

Version	Information about changes
V2.3.1	<p>The following changes have been made:</p> <ul style="list-style-type: none">• The Voltage Standing Wave Ratio (VSWR) at the 50 Ω socket of the Test Fixture defined in clause 5.1.6 has been reduced to a maximum value of 1,2 for frequencies below 2 100 MHz.• The maximum relative drift radio frequency in measurement uncertainty has been reduced to ± 1 kHz (table F.1).• Moved Measurement uncertainties to an Informative annex.• The spurious emissions limits given in clause 4.5.6.5.2, table 7 have been clarified to reflect they are relative to edge carriers.• The definitions of the extreme test conditions have been clarified.• Replacement of manufacturer's declaration with dedicated tests.

History

Document history		
Edition 1	December 1993	Publication as ETSI TBR 006
Edition 2	January 1997	Publication as ETSI TBR 006
Edition 3	June 1999	Publication as ETSI TBR 006
V1.4.1	March 2001	Publication as ETSI EN 301 406
V1.5.1	July 2003	Publication as ETSI EN 301 406
V2.1.1	July 2009	Publication as ETSI EN 301 406
V2.2.1	April 2016	Publication as ETSI EN 301 406 (Withdrawn)
V2.2.2	September 2016	Publication as ETSI EN 301 406
V2.3.0	July 2022	EN Approval Procedure AP 20221027: 2022-07-29 to 2022-10-27