

ETSI EN 301 401 V1.2.6 (1999-10)

Candidate Harmonized European Standard (Telecommunications series)

**Attachment requirements for Data Terminal Equipment (DTE)
to connect to public networks that have physical
and electrical network presentations based upon
the ITU-T V-series of Recommendations**



Reference

DEN/DTA-000002 (cz000is0.PDF)

Keywords

PSPDN, X.21

ETSI

Postal address

F-06921 Sophia Antipolis Cedex - FRANCE

Office address

650 Route des Lucioles - Sophia Antipolis
Valbonne - FRANCE
Tel.: +33 4 92 94 42 00 Fax: +33 4 93 65 47 16
Siret N° 348 623 562 00017 - NAF 742 C
Association à but non lucratif enregistrée à la
Sous-Préfecture de Grasse (06) N° 7803/88

Internet

secretariat@etsi.fr
Individual copies of this ETSI deliverable
can be downloaded from
<http://www.etsi.org>
If you find errors in the present document, send your
comment to: editor@etsi.fr

Important notice

This ETSI deliverable may be made available in more than one electronic version or in print. In any case of existing or perceived difference in contents between such versions, the reference version is the Portable Document Format (PDF). In case of dispute, the reference should be the printing on ETSI printers of the PDF version kept on a specific network drive within ETSI Secretariat.

Copyright Notification

No part may be reproduced except as authorized by written permission.
The copyright and the foregoing restriction extend to reproduction in all media.

© European Telecommunications Standards Institute 1999.
All rights reserved.

Contents

Intellectual Property Rights	6
Foreword	6
1 Scope	7
2 References	7
3 Definitions and abbreviations	8
3.1 Definitions	8
3.2 Abbreviations	9
4 Safety and EMC requirements	9
4.1 Safety requirements	9
4.2 EMC requirements	9
5 Applicability of Standard	9
6 Electrical, mechanical, and access control protocol requirements	10
6.1 General characteristics	10
6.1.1 Generator presentations	10
6.1.1.1 Balanced generator	10
6.1.1.2 Unbalanced generator	10
6.2 Connector characteristics and contact number assignments	10
6.2.1 Attachment to a DCE interface presented on a 25-pole connector	10
6.2.1.1 Connector	10
6.2.1.2 Contact number assignments	10
6.2.2 Attachment to a DCE interface presented on a 26-pole connector	11
6.2.2.1 Connector	11
6.2.2.2 Contact number assignments	11
6.2.3 Attachment to a DCE interface presented on a 37-pole connector	11
6.2.3.1 Connector	11
6.2.3.2 Contact number assignments	11
6.2.4 Attachment to a DCE interface presented on a 34-pole connector	11
6.2.4.1 Connector	11
6.2.4.2 Contact number assignments	12
6.2.5 Attachment to a DCE interface presented on a 15-pole connector	12
6.2.5.1 Connector	12
6.2.5.2 Contact number assignments	12
6.2.6 Attachment to a DCE interface presented on a 50-pole connector	12
6.2.6.1 Connector	12
6.2.6.2 Contact number assignments	12
6.3 Electrical requirements	13
6.3.1 Requirements for attachment to ITU-T Recommendation V.10 interchange circuits	13
6.3.1.1 Generator open circuit output voltage	13
6.3.2 Requirements for attachment to ITU-T Recommendation V.11 interchange circuits	13
6.3.2.1 Generator open circuit output voltage	14
6.3.3 Requirements for attachment to ITU-T Recommendation V.12 interchange circuits	14
6.3.3.1 Generator open circuit output voltage	14
6.3.4 Requirements for attachment to ITU-T Recommendation V.28 interchange circuits	15
6.3.4.1 Generator open circuit output voltage	15
6.3.5 Requirements for attachment to CCITT Recommendation V.35 interchange circuits	15
6.3.5.1 Generator open circuit output voltage	15
6.3.6 Requirements for attachment to ITU-T Recommendation V.36 interchange circuits	16
6.3.6.1 Generator open circuit output voltage	16
7 Test Specification	16
7.1 Conditions of test	16
7.1.1 Environment for tests	16
7.1.2 Power supply limitations	16

7.1.3	Test condition.....	17
7.1.4	Test point	17
7.1.5	Bit patterns	17
7.1.6	Signal element timing.....	17
7.1.7	Interchange circuits presentation.....	17
7.1.8	Physical layer tests	17
7.1.8.1	Verification of the electrical characteristics	17
7.1.8.2	Identically implemented circuits.....	17
7.1.8.3	Fixed state generators	18
7.2	Test descriptions for connector characteristics and contact number assignments.....	18
7.2.1	25-pole connector.....	18
7.2.1.1	Connector characteristics.....	18
7.2.1.2	Contact number assignments	18
7.2.2	26-pole connector.....	18
7.2.2.1	Connector characteristics.....	18
7.2.2.2	Contact number assignments	18
7.2.2.2.1	Connection to a DCE presenting ITU-T Recommendation V.10 or V.11 electrical characteristics.....	18
7.2.2.2.2	Connection to a DCE presenting ITU-T Recommendation V.28 electrical characteristics.....	19
7.2.3	37-pole connector.....	19
7.2.3.1	Connector characteristics.....	19
7.2.3.2	Contact number assignments	19
7.2.4	34-pole connector.....	19
7.2.4.1	Connector characteristics.....	19
7.2.4.2	Contact number assignments	19
7.2.5	15-pole connector.....	19
7.2.5.1	Connector characteristics.....	19
7.2.5.2	Contact number assignments	20
7.2.6	50-pole connector.....	20
7.2.6.1	Connector characteristics.....	20
7.2.6.2	Contact number assignments	20
7.3	Test descriptions for attachment to ITU-T Recommendation V.10 interchange circuits	20
7.3.1	Generator characteristics	20
7.3.1.1	Generator open circuit output voltage	20
7.4	Test descriptions for attachment to ITU-T Recommendation V.11 interchange circuits	21
7.4.1	Generator characteristics	21
7.4.1.1	Generator open circuit output voltage	21
7.5	Test descriptions for attachment to ITU-T Recommendation V.12 interchange circuits	22
7.5.1	Generator characteristics	22
7.5.1.1	Generator open circuit output voltage	22
7.6	Test descriptions for attachment to ITU-T Recommendation V.28 interchange circuits	23
7.6.1	Generator characteristics	23
7.6.1.1	Generator open circuit output voltage	23
7.7	Test descriptions for attachment to CCITT Recommendation V.35 interchange circuits	24
7.7.1	Generator characteristics	24
7.7.1.1	Generator open circuit output voltage	24
7.8	Test case selection expression definition table	25
7.9	Test case Index	26
Annex A (normative): The Requirements Table (RT)		28
A.1	Introduction to the RT	28
A.2	Format of the tables	28
A.3	Notations used in the RT	29
A.3.1	Status notations.....	29
A.3.2	Support answer notations.....	29
A.4	The Harmonized Standard Requirement Tables.....	29
A.4.1	Means of connection to the DCE.....	29
A.4.2	Connection to a DCE presenting an ISO 2110 (25-pole) connector	30

A.4.3	Connection to a DCE presenting an ISO/IEC 11569 (26-pole) connector.....	31
A.4.4	Connection to a DCE presenting an ISO 4902 (37-pole) connector	34
A.4.5	Connection to a DCE presenting an ISO 2593 (34-pole) connector	36
A.4.6	Connection to a DCE presenting an ISO 4903 (15-pole) connector	38
A.4.7	Connection to a DCE presenting an TIA/EIA-613 (50-pole) connector	40
Annex B (normative): Physical layer implementation extra information for testing (PIXIT)....		42
Bibliography		43
History.....		44

Intellectual Property Rights

IPRs essential or potentially essential to the present document may have been declared to ETSI. The information pertaining to these essential IPRs, if any, is publicly available for **ETSI members and non-members**, and can be found in SR 000 314: "*Intellectual Property Rights (IPRs); Essential, or potentially Essential, IPRs notified to ETSI in respect of ETSI standards*", which is available from the ETSI Secretariat. Latest updates are available on the ETSI Web server (<http://www.etsi.org/ipr>).

Pursuant to the ETSI IPR Policy, no investigation, including IPR searches, has been carried out by ETSI. No guarantee can be given as to the existence of other IPRs not referenced in SR 000 314 (or the updates on the ETSI Web server) which are, or may be, or may become, essential to the present document.

Foreword

This Candidate Harmonized European Standard (Telecommunications series) has been produced by ETSI Project Digital Terminals and Access (DTA).

The present document has been produced by ETSI in response to a mandate from the European Commission issued under Council Directive 98/34/EC [4] (as amended) laying down a procedure for the provision of information in the field of technical standards and regulations.

The present document is intended to become a Harmonized Standard, the reference of which may be published in the Official Journal of the European Communities referencing the Council Directive 98/13/EC [3] on the approximation of the laws of the Member States concerning telecommunications terminal equipment, including the mutual recognition of their conformity ("the TTE Directive").

Technical specifications relevant to the TTE Directive are given in annex A.

National transposition dates	
Date of adoption of this EN:	22 October 1999
Date of latest announcement of this EN (doa):	31 January 2000
Date of latest publication of new National Standard or endorsement of this EN (dop/e):	31 July 2000
Date of withdrawal of any conflicting National Standard (dow):	31 July 2000

1 Scope

The present document specifies the technical characteristics to be provided by terminal equipment to be connected to public networks presented at an ITU-T Recommendations V.10 [10], V.11 [11] (including X.26 [21] and X.27 [22]), V.12 [12], V.24 [13]/V.28 [14], V.35 [15] or V.36 [16] interface regardless of data rate. The objective of the present document is to ensure that no disturbance occurs to the public network.

The present document contains the minimum set of requirements derived from the above set of ITU-T Recommendations and is applicable for connection to X.21 [18] leased line and circuit switched, X.21 bis [19] leased lines, X.25, Frame Relay and SMDS plus any other public network service that may be presented on the same electrical interfaces.

NOTE: Not all of the above services are available in all countries.

A test is given for each requirement in the present document, including measurement methods. Requirements apply at the public network interface of the terminal equipment, which may be stimulated to perform the tests by additional equipment if necessary.

Terminal equipment may be subject to additional or alternative requirements depending on its functionality, in particular if it supports a service that is considered to be a justified case for regulation of terminal interworking via the telecommunications network.

2 References

The following documents contain provisions which, through reference in this text, constitute provisions of the present document.

- References are either specific (identified by date of publication, edition number, version number, etc.) or non-specific.
- For a specific reference, subsequent revisions do not apply.
- For a non-specific reference, the latest version applies.
- A non-specific reference to an ETS shall also be taken to refer to later versions published as an EN with the same number.

- [1] Council Directive 73/23/EEC of February 1973 on the harmonization of the laws of the Member States relating to electrical equipment designed for use within certain voltage limits (Low Voltage Directive).
- [2] Council Directive 89/336/EEC of 3 May 1989 on the approximation of the laws of Member States relating to electromagnetic compatibility.
- [3] Council Directive 98/13/EEC of 12 February 1998 relating to telecommunications terminal equipment and satellite earth station equipment, including the mutual recognition of their conformity.
- [4] Council Directive 98/34/EC of 22 June 1998 laying down a procedure for the provision of information in the field of technical standards and regulations.
- [5] ISO 2110 (1980): "Information technology - Data communication - 25-pole DTE/DCE interface connector and contact number assignments".
- [6] ISO 2593 (1984): "Information technology - Telecommunications and information exchange between systems - 34-pole DTE/DCE interface connector and contact number assignments".
- [7] ISO 4902 (1980): "Information technology - Data communication - 37-pole DTE/DCE interface connector and contact number assignments".

- [8] ISO 4903 (1989): "Information technology - Data communication - 15-pole DTE/DCE interface connector and contact number assignments".
- [9] ISO/IEC 11569 (1992): "Information technology - Telecommunications and information exchange between systems - 26-pole interface connector mateability dimensions and contact number assignments".
- [10] ITU-T Recommendation V.10 (1993): "Electrical characteristics for unbalanced double-current interchange circuits operating at data signalling rates nominally up to 100 kbit/s".
- [11] ITU-T Recommendation V.11 (1996): "Electrical characteristics for balanced double-current interchange circuits operating at data signalling rates up to 10 Mbit/s".
- [12] ITU-T Recommendation V.12 (1995): "Electrical characteristics for balanced double-current interchange circuits for interfaces with data signalling rates up to 52 Mbit/s."
- [13] ITU-T Recommendation V.24: "List of definitions for interchange circuits between data terminal equipment (DTE) and data circuit-terminating equipment (DCE)".
- [14] ITU-T Recommendation V.28 (1993): "Electrical characteristics for unbalanced double-current interchange circuits".
- [15] CCITT Recommendation V.35 (1984): "Data transmission at 48 kilobits per second using 60-108 kHz group band circuits - Appendix II Electrical characteristics for balanced double-current interchange circuits".
- [16] ITU-T Recommendation V.36: "Modems for synchronous data transmission using 60-108 kHz group band circuits".
- [17] ITU-T Recommendation X.2 (1996): "International data transmission services and optional user facilities in public data networks and ISDNs".
- [18] ITU-T Recommendation X.21 (1992): "Interface between Data Terminal Equipment and Data Circuit-terminating Equipment for synchronous operation on public data networks".
- [19] ITU-T Recommendation X.21 bis: "Use on public data networks of Data Terminal Equipment (DTE) which is designed for interfacing to synchronous V-Series modems".
- [20] ITU-T Recommendation X.25 (1996): "Interface between Data Terminal Equipment (DTE) and Data Circuit-terminating Equipment (DCE) for terminals operating in the packet mode and connected to public data networks by dedicated circuit".
- [21] ITU-T Recommendation X.26: "see ITU-T Recommendation V.10".
- [22] ITU-T Recommendation X.27: "See ITU-T Recommendation V.11".
- [23] TIA/EIA-613: "High Speed Serial Interface for Data Terminal Equipment and Data Circuit-Terminating Equipment".

3 Definitions and abbreviations

3.1 Definitions

For the purposes of the present document, the following terms and definitions apply:

ITU-T Recommendation X.25 [20] network: PSPDN network which offers a ITU-T Recommendation X.25 [20] DTE/DCE interface providing the (E) facilities for user classes of service 8-11 as defined in ITU-T Recommendation X.2, [17].

All other definitions are as given in the ITU-T series of Recommendations.

3.2 Abbreviations

For the purposes of the present document, the following abbreviations apply:

ac	alternating current
dc	direct current
DCE	Data Circuit terminating Equipment
DTE	Data Terminal Equipment
EMC	ElectroMagnetic Compatibility
RT	Requirements Table
IUT	Implementation Under Test
PIXIT	Protocol Implementation eXtra Information for Testing
PSPDN	Packet Switched Public Data Network
TBR	Technical Basis for Regulation
TE	Terminal Equipment
Vo	open-circuit generator voltage

4 Safety and EMC requirements

4.1 Safety requirements

There are no safety requirements contained within the present document.

NOTE: Safety requirements are imposed under the Low Voltage Directive (73/23/EEC) [1] and articles 5 (a) and 5 (b) of Directive 98/13/EEC [3].

4.2 EMC requirements

There are no EMC requirements contained within the present document.

NOTE: General EMC requirements are imposed under EMC Directive (89/336/EEC) [2] and article 5 (c) of Directive 98/13/EEC [3].

5 Applicability of Standard

The requirements in the present document are applicable to DTE intended to be connected to DCE interfaces on public networks providing one or more of the following services:

- circuit switched data transmission service;
- packet switched data transmission service;
- leased circuit data transmission service;
- frame relay data transmission service, or

any other service presented via an ITU-T V series interface.

6 Electrical, mechanical, and access control protocol requirements

The requirements of this clause apply at the means of connection to the DCE.

6.1 General characteristics

6.1.1 Generator presentations

6.1.1.1 Balanced generator

In the case of balanced terminal equipment generators, points A and B are defined as the two physical connections, on the means provided for connection to the DCE, to which the output of a terminal generator is connected, and point C is the physical connection on the means of connection to the DCE to which the terminal equipment signal ground may optionally be connected (see figure 2).

6.1.1.2 Unbalanced generator

In the case of unbalanced terminal equipment generators, point A is defined as the physical connection on the means provided for connection to the DCE, to which the output of a terminal generator is connected, and point C is the physical connection on the means of connection to the DCE to which the signal ground associated with that generator is connected.

6.2 Connector characteristics and contact number assignments

The means of connection to the DCE should conform to either subclauses 6.2.1, 6.2.2, 6.2.3, 6.2.4, 6.2.5 or 6.2.6.

A manufacturer employing an alternative means of connection shall declare details of this arrangement in a format similar to the Requirements Table (RT) contained in annex A. This declaration shall include details of circuit allocation and, information about the ITU-T V series Recommendations against which compliance is to be assessed. Compliance of such alternative connection characteristics shall be checked in a way similar to the tests described in subclause 7.2, if appropriate.

6.2.1 Attachment to a DCE interface presented on a 25-pole connector

6.2.1.1 Connector

The means of connection to the DCE shall be a male connector conforming to ISO 2110 [5].

NOTE: This requirement is based upon subclause 1.2 of ITU-T Recommendation X.21 bis [19].

Compliance shall be checked by the test given in subclause 7.2.1.1.

Justification: Directive 98/13/EEC [3], article 5 (d).

6.2.1.2 Contact number assignments

On the means of connection to the DCE, the presentation of the interchange circuits shall be in accordance with annex A, tables A.2 and A.3.

NOTE: This requirement is based upon subclause 1.2 of ITU-T Recommendation X.21 bis [19] and ISO 2110 [5].

Compliance shall be checked as described in subclause 7.2.1.2.

Justification: Directive 98/13/EEC [3], article 5 (d).

6.2.2 Attachment to a DCE interface presented on a 26-pole connector

6.2.2.1 Connector

The means of connection to the DCE shall be a male connector conforming to ISO/IEC 11569 [9].

NOTE: This requirement is based upon ISO/IEC 11569 [9].

Compliance shall be checked by the test given in subclause 7.2.2.1 as appropriate.

Justification: Directive 98/13/EEC [3], article 5 (d).

6.2.2.2 Contact number assignments

On the means of connection to the DCE, the presentation of the interchange circuits shall be in accordance with annex A, tables A.6 and A.7 or tables A.10 and A.11.

NOTE: This requirement is based upon ISO/IEC 11569 [9].

Compliance shall be checked as described in subclause 7.2.2.2 as appropriate.

Justification: Directive 98/13/EEC [3], article 5 (d).

6.2.3 Attachment to a DCE interface presented on a 37-pole connector

6.2.3.1 Connector

The means of connection to the DCE shall be a male connector conforming to ISO 4902 [7].

NOTE: This requirement is based upon subclause 1.2 of ITU-T Recommendation X.21 bis [19].

Compliance shall be checked by the test given in subclause 7.2.3.1 as appropriate.

Justification: Directive 98/13/EEC [3], article 5 (d).

6.2.3.2 Contact number assignments

On the means of connection to the DCE, the presentation of the interchange circuits shall be in accordance with annex A, tables A.13 and A.14.

NOTE: This requirement is based upon subclause 1.2 of ITU-T Recommendation X.21 bis [19] and ISO 4902 [7].

Compliance shall be checked as described in subclause 7.2.3.2 as appropriate.

Justification: Directive 98/13/EEC [3], article 5 (d).

6.2.4 Attachment to a DCE interface presented on a 34-pole connector

6.2.4.1 Connector

The means of connection to the DCE shall be a male connector conforming to ISO 2593 [6].

NOTE: This requirement is based upon subclause 1.2 of ITU-T Recommendation X.21 bis [19].

Compliance shall be checked by the test given in subclause 7.2.4.1 as appropriate.

Justification: Directive 98/13/EEC [3], article 5 (d).

6.2.4.2 Contact number assignments

On the means of connection to the DCE, the presentation of the interchange circuits shall be in accordance with annex A, tables A.17 and A.18.

NOTE: This requirement is based upon subclause 1.2 of ITU-T Recommendation X.21 bis [19] and ISO 2593 [6].

Compliance shall be checked as described in subclause 7.2.4.2 as appropriate.

Justification: Directive 98/13/EEC [3], article 5 (d).

6.2.5 Attachment to a DCE interface presented on a 15-pole connector

6.2.5.1 Connector

The means of connection to the DCE shall be a male connector conforming to ISO 4903 [8].

NOTE: This requirement is based upon subclause 2.2 of ITU-T Recommendation X.21 [18].

Compliance shall be checked by the test given in subclause 7.2.5.1 as appropriate.

Justification: Directive 98/13/EEC [3], article 5 (d).

6.2.5.2 Contact number assignments

On the means of connection to the DCE, the presentation of the interchange circuits shall be in accordance with annex A, tables A.23 and A.24.

NOTE: This requirement is based upon subclause 2.2 of ITU-T Recommendation X.21 [18] and ISO 4903 [8].

Compliance shall be checked as described in subclause 7.2.5.2 as appropriate.

Justification: Directive 98/13/EEC [3], article 5 (d).

6.2.6 Attachment to a DCE interface presented on a 50-pole connector

6.2.6.1 Connector

The means of connection to the DCE shall be a male connector conforming to TIA/EIA-613 [23].

NOTE: This requirement is based upon subclause 2.2 of ITU-T Recommendation X.21 [18].

Compliance shall be checked by the test given in subclause 7.2.6.1 as appropriate.

Justification: Directive 98/13/EEC [3], article 5 (d).

6.2.6.2 Contact number assignments

On the means of connection to the DCE, the presentation of the interchange circuits shall be in accordance with annex A, tables A.27 and A.28.

NOTE: This requirement is based upon subclause 2.2 of ITU-T Recommendation X.21 [18] and TIA/EIA-613 [23].

Compliance shall be checked as described in subclause 7.2.6.2 as appropriate.

Justification: Directive 98/13/EEC [3], article 5 (d).

6.3 Electrical requirements

For a particular terminal implementation, the generator requirements of the present document apply only to the extent that they are relevant to a particular generator. For instance, where, in a particular terminal implementation, a particular generator circuit, in normal operation, is fixed in one of the binary states, only those requirements relevant to that fixed binary state shall apply.

NOTE: It is possible for particular interchange circuits of a TE to be intended for connection to more than one type of interchange circuit which could be presented by a DCE (e.g. to both ITU-T Recommendations V.10 [10] and V.28 [14]).

Where an interchange circuit, presented by the TE, to which a particular section of subclause 6.3 applies, is intended to be connected additionally to interchange circuits presented by a DCE which conform to other sections of subclause 6.3, the requirements of that section of subclause 6.3 relevant to those characteristics also apply.

Additionally, for a particular DTE-DCE interface, not all signals may be employing the same interchange circuit characteristics. It is the interchange characteristic of the individual signals presented by the network that dictate which sections of subclause 6.3 apply.

6.3.1 Requirements for attachment to ITU-T Recommendation V.10 interchange circuits

The requirements of this subclause apply to interchange circuits, presented by the TE on the means for connection to the DCE, that are intended for connection to circuits presented by the DCE that conform to ITU-T Recommendation V.10 [10].

6.3.1.1 Generator open circuit output voltage

When a $3\,900\ \Omega$ non-reactive impedance is connected between points A and C, for each binary state, the magnitude of the voltage between points A and C shall be less than or equal to 12,0 V.

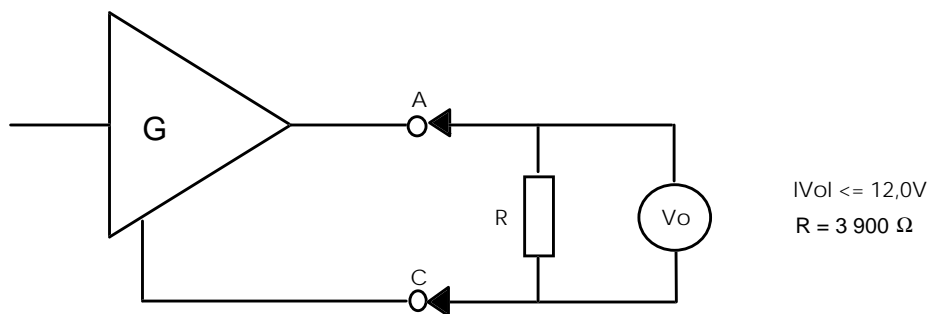

NOTE: This requirement is based upon ITU-T Recommendation V.10 [10] subclauses 5.2.1 and 6.3.

Figure 1

Compliance shall be verified in accordance with the test specified in subclause 7.3.1.1.

Justification: Directive 98/13/EEC [3], article 5 (d).

6.3.2 Requirements for attachment to ITU-T Recommendation V.11 interchange circuits

The requirements of this subclause apply to interchange circuits, presented by the TE on the means for connection to the DCE, intended for connection to circuits presented by the DCE that conform to ITU-T Recommendation V.11 [11].

6.3.2.1 Generator open circuit output voltage

When a $3\,900\ \Omega$ non-reactive impedance is connected between points A and B, for each binary state (see figure 2):

- the magnitude of the voltage between points A and B shall be less than or equal to 12,0 V;
- the magnitude of the voltage between either points A or B and point C shall be less than or equal to 12,0 V.

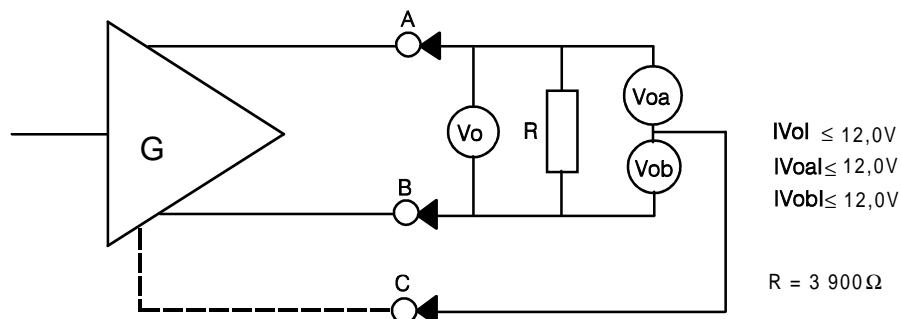

NOTE: This requirement is based upon ITU-T Recommendation V.11 [11] subclauses 5.2.1 and 6.3.

Figure 2

Compliance shall be verified in accordance with the test specified in subclause 7.4.1.1.

Justification: Directive 98/13/EEC [3], article 5 (d).

6.3.3 Requirements for attachment to ITU-T Recommendation V.12 interchange circuits

The requirements of this subclause apply to interchange circuits, presented by the TE on the means for connection to the DCE, that are intended for connection to circuits presented by the DCE that conform to ITU-T Recommendation V.12 [12].

6.3.3.1 Generator open circuit output voltage

When connected as shown in figure 3, the magnitude of the voltage between points A and C shall be less than or equal to 1,5 V.

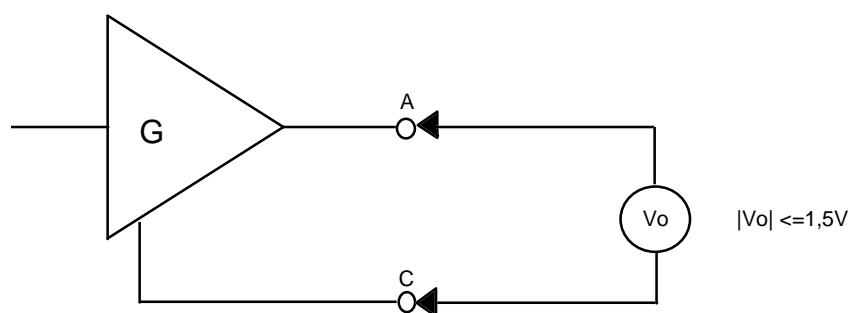

NOTE: This requirement is based upon ITU-T Recommendation V.12 [12] subclause 4.1.1.

Figure 3

Compliance shall be verified in accordance with the test specified in subclause 7.5.1.1.

Justification: Directive 98/13/EEC [3], article 5 (d).

6.3.4 Requirements for attachment to ITU-T Recommendation V.28 interchange circuits

The requirements of this subclause apply to interchange circuits, presented by the TE on the means for connection to the DCE, that are intended for connection to circuits presented by the DCE that conform to ITU-T Recommendation V.28 [14].

6.3.4.1 Generator open circuit output voltage

When connected as shown in figure 4, the magnitude of the voltage between points A and C shall be less than or equal to 25,0 V.

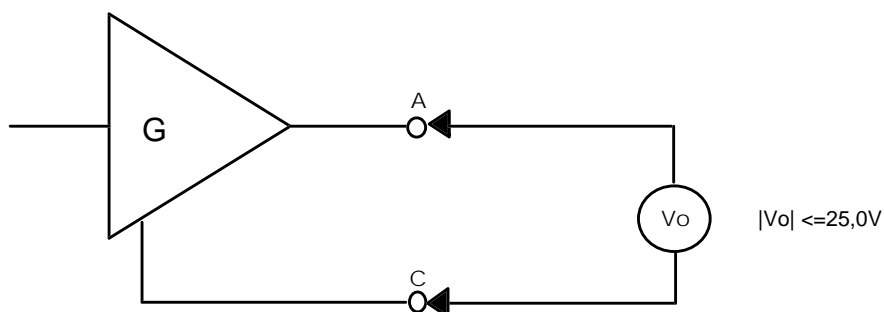

NOTE: This requirement is based upon ITU-T Recommendation V.28 [14] subclause 4.

Figure 4

Compliance shall be verified in accordance with the test specified in subclause 7.6.1.1.

Justification: Directive 98/13/EEC [3], article 5 (d).

6.3.5 Requirements for attachment to CCITT Recommendation V.35 interchange circuits

The requirements of this subclause apply to interchange circuits, presented by the TE on the means for connection to the DCE, that are intended for connection to circuits presented by the DCE that conform to CCITT Recommendation V.35 [15].

6.3.5.1 Generator open circuit output voltage

When terminated with a 3 900 Ω non-reactive impedance connected between points A and B (see figure 5), for each binary state:

- a) the magnitude of the voltage between points A and B shall be less than or equal to 1,2 V;
- b) the magnitude of the voltage between either points A or B and point C shall be less than or equal to 1,2 V.

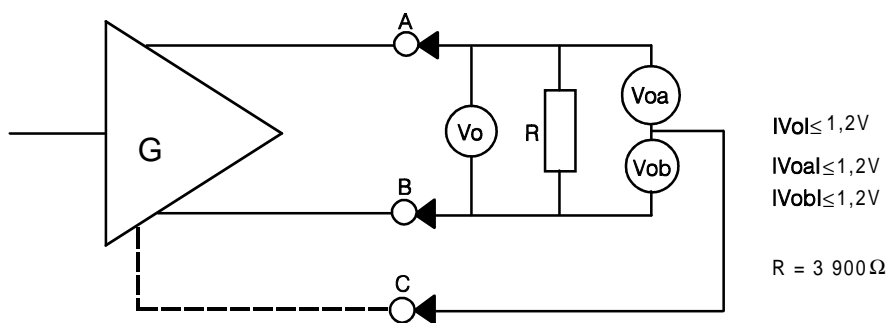

NOTE: This requirement is based upon CCITT Recommendation V.35 [15] annex 2 subclause 5.2.3.

Figure 5

Compliance shall be verified in accordance with the test specified in subclause 7.7.1.1.

Justification: Directive 98/13/EEC [3], article 5 (d).

6.3.6 Requirements for attachment to ITU-T Recommendation V.36 interchange circuits

The requirements of this subclause apply to interchange circuits, presented by the TE on the means for connection to the DCE, that are intended for connection to circuits presented by the DCE that conform to ITU-T Recommendation V.36 [16].

6.3.6.1 Generator open circuit output voltage

Interchange circuits that conform to ITU-T Recommendation V.36 [16] have electrical characteristics conforming to either ITU-T Recommendation V.10 [10] and/or ITU-T Recommendation V.11 [11]. The manufacturer shall declare which interchange circuits exhibit which characteristics, and these shall be verified in accordance with the requirements specified in subclauses 6.3.1.1 and 6.3.2.1.

Justification: Directive 98/13/EEC [3], article 5 (d).

7 Test Specification

7.1 Conditions of test

7.1.1 Environment for tests

All tests shall be performed at:

- a) an ambient temperature in the range 15°C to 35°C;
- b) a relative humidity in the range of 5 % to 75 %.

The tests shall not be performed outside the operating limits for the terminal equipment as stated by the client.

7.1.2 Power supply limitations

For apparatus that is directly powered from the mains supply all tests shall be carried out within ± 5 % of the normal operating voltage.

If apparatus is powered by other means and those means are not supplied as part of the apparatus, e.g. batteries, stabilized ac supplies, dc, etc., all tests shall be carried out within the power supply limit declared by the supplier. If the power supply is ac., the tests shall be conducted within ± 4 % of the stated frequency as declared by the supplier.

7.1.3 Test condition

All requirements apply and tests are carried out with the terminal in the "power on" condition unless otherwise stated.

7.1.4 Test point

Tests shall be carried out at the point of connection to the DCE on the means provided by the terminal equipment for connecting to the DCE.

In order to carry out these tests the client shall provide a means of connecting the terminal equipment to a DCE (e.g. a cable) which is representative of the means of connecting to a DCE intended to be used by, or supplied with the apparatus.

The definition of points A, B, and C in respect of generators is contained in subclause 6.1.1.

7.1.5 Bit patterns

It may be necessary in certain instances, for the tester to send specified bit patterns to the terminal equipment to ensure that a particular state is maintained. The applicant shall inform the test laboratory of such cases and specify the nature of the bit patterns to be sent.

7.1.6 Signal element timing

For some terminal equipment it may be necessary to provide Signal Element Timing in order to carry out the tests specified in the present document. Where this is necessary it shall be at a data signalling rate appropriate for the equipment under test. The applicant shall inform the test laboratory of such cases and specify the nature of the Signal Element Timing to be supplied.

7.1.7 Interchange circuits presentation

The tester shall assume that the interchange circuits are presented on the means for connection to the DCE on the poles of the connector as declared in the RT in annex A.

7.1.8 Physical layer tests

7.1.8.1 Verification of the electrical characteristics

Verification of the electrical characteristics shall be based upon either:

- a) the tests described in subclauses 7.2, 7.3, 7.4, 7.5, 7.6, or 7.7 as appropriate; or
- b) by agreement between the client and the test laboratory, the submission by the client to the test laboratory of a declaration of conformance, including circuit diagrams, component specifications, and other relevant information. The test laboratory shall, on the basis of the evidence accompanying the declaration, be responsible for satisfying itself that the declaration gives assurance of conformity not less than that achieved by method a) above.

7.1.8.2 Identically implemented circuits

Where, for the purpose of testing, two or more circuits are identically implemented, the test need only be carried out on one of them.

This shall be declared by the client in annex B, table B.2.

7.1.8.3 Fixed state generators

Where, for particular terminal equipment, a certain state is not relevant for a specific interchange for a specific interchange circuit, there is no requirement for that generator output state to be tested in respect of that interchange circuit.

This shall be declared by the client in annex B, table B.1.

7.2 Test descriptions for connector characteristics and contact number assignments

7.2.1 25-pole connector

7.2.1.1 Connector characteristics

An attempt shall be made to mate the connector provided by the terminal equipment for connecting it to a DCE with an ISO 2110 [5] compliant connector with female contacts.

Successful mechanical mating shall occur.

7.2.1.2 Contact number assignments

The client shall complete the RT contained in annex A:

- a) circuits shown in annex A, table A.2 or A.3 as mandatory (m) shall be declared as implemented;
- b) it is also permitted for circuits shown in annex A, table A.2 or A.3 as optional (o) to be declared as implemented.

Compliance shall be verified by static conformance review of the completed form.

7.2.2 26-pole connector

7.2.2.1 Connector characteristics

An attempt shall be made to mate the connector provided by the terminal equipment for connecting it to a DCE with an ISO/IEC 11569 [9] compliant connector with female contacts.

Successful mechanical mating shall occur.

7.2.2.2 Contact number assignments

7.2.2.2.1 Connection to a DCE presenting ITU-T Recommendation V.10 or V.11 electrical characteristics

The client shall complete RT contained in annex A:

- a) circuits shown in annex A, table A.6 or A.7 as mandatory (m) shall be declared as implemented;
- b) it is also permitted for circuits shown in annex A, table A.6 or A.7 as optional (o) to be declared as implemented.

Compliance shall be verified by static conformance review of the completed form.

7.2.2.2.2 Connection to a DCE presenting ITU-T Recommendation V.28 electrical characteristics

The client shall complete RT contained in annex A:

- a) circuits shown in annex A, table A.10 or A.11 as mandatory (m) shall be declared as implemented;
- b) it is also permitted for circuits shown in annex A, table A.10 or A.11 as optional (o) to be declared as implemented.

Compliance shall be verified by Static Conformance Review of the completed form.

7.2.3 37-pole connector

7.2.3.1 Connector characteristics

An attempt shall be made to mate the connector provided by the terminal equipment for connecting it to a DCE with an ISO 4902 [7] compliant connector with female contacts.

Successful mechanical mating shall occur.

7.2.3.2 Contact number assignments

The client shall complete RT contained in annex A:

- a) circuits shown in annex A, table A.13 or A.14 as mandatory (m) shall be declared as implemented;
- b) it is also permitted for circuits shown in annex A, table A.13 or A.14 as optional (o) to be declared as implemented.

Compliance shall be verified by static conformance review of the completed form.

7.2.4 34-pole connector

7.2.4.1 Connector characteristics

An attempt shall be made to mate the connector provided by the terminal equipment for connecting it to a DCE with an ISO 2593 [6] compliant connector with female contacts.

Successful mechanical mating shall occur.

7.2.4.2 Contact number assignments

The client shall complete RT contained in annex A:

- a) circuits shown in annex A, table A.17 or A.18 as mandatory (m) shall be declared as implemented;
- b) it is also permitted for circuits shown in annex A, table A.17 or A.18 as optional (o) to be declared as implemented.

Compliance shall be verified by static conformance review of the completed form.

7.2.5 15-pole connector

7.2.5.1 Connector characteristics

An attempt shall be made to mate the connector provided by the terminal equipment for connecting it to a DCE with an ISO 4903 [8] compliant connector with female contacts.

Successful mechanical mating shall occur.

7.2.5.2 Contact number assignments

The client shall complete RT contained in annex A:

- a) circuits shown in annex A, table A.23 or A.24 as mandatory (m) shall be declared as implemented;
- b) it is also permitted for circuits shown in annex A, table A.23 or A.24 as optional (o) to be declared as implemented.

Compliance shall be verified by static conformance review of the completed form.

7.2.6 50-pole connector

7.2.6.1 Connector characteristics

An attempt shall be made to mate the connector provided by the terminal equipment for connecting it to a DCE with an TIA/EIA-613 [23] compliant connector with female contacts.

Successful mechanical mating shall occur.

7.2.6.2 Contact number assignments

The client shall complete RT contained in annex A:

- a) circuits shown in annex A, table A.27 or A.28 as mandatory (m) shall be declared as implemented;
- b) it is also permitted for circuits shown in annex A, table A.27 or A.28 as optional (o) to be declared as implemented.

Compliance shall be verified by static conformance review of the completed form.

7.3 Test descriptions for attachment to ITU-T Recommendation V.10 interchange circuits

7.3.1 Generator characteristics

7.3.1.1 Generator open circuit output voltage

Test purpose:

This test is to demonstrate compliance with the requirements of subclause 6.3.1.1.

Test considerations:

This test is most easily performed using signals that do not make transitions from one binary state to another while measurement is in progress. However, these tests may be carried out using other signal patterns which the terminal is capable of generating. In this case the effects of transient signal conditions shall be disregarded.

Test Configuration:

A 3 900 Ω non-reactive impedance (R1) is connected between points A and C. A device for measuring dc. voltage is connected across points A and C. Point C shall be taken as circuit 102a for ISO 4902 [7] and circuit 102 for ISO 4903 [8] implementations.

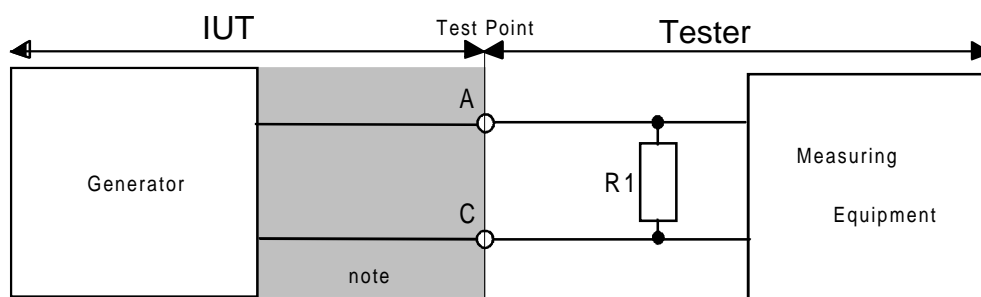

NOTE: The shaded area denotes an interconnection means e.g. Interface cable and connector.

Figure 6

IUT interface state:

The Implementation Under Test (IUT) shall be powered.

Test stimulus and action:

The IUT is stimulated to generate each of the binary states for the generator under test. The test shall be repeated for each generator to be tested. The dc. voltage shall be measured between points A and C.

Expected results:

The magnitude of the voltages measured between points A and C shall be less than or equal to 12,0 V for each binary state.

7.4 Test descriptions for attachment to ITU-T Recommendation V.11 interchange circuits

7.4.1 Generator characteristics

7.4.1.1 Generator open circuit output voltage

Test purpose:

This test is to demonstrate compliance with the requirements of subclause 6.3.2.1.

Test considerations:

This test is most easily performed using signals that do not make transitions from one binary state to another whilst measurement is in progress. However, these tests may be carried out using signal patterns which the terminal is capable of generating. In this case the effects of transient signal conditions shall be disregarded.

Test Configuration:

Point C shall be taken as circuit 102a for ISO 4902 [7] and circuit 102 for ISO 4903 [8] implementations:

- a 3 900 Ω non-reactive impedance (R1) is connected between points A and B. A device for measuring dc. voltage (V_o) is connected between points A and B;
- a 3 900 Ω non-reactive impedance (R1) is connected between points A and B. A device for measuring dc. voltage (V_{oa}) is connected between points A and C;
- a 3 900 Ω non-reactive impedance (R1) is connected between points A and B. A device for measuring dc. voltage (V_{ob}) is connected between points B and C.

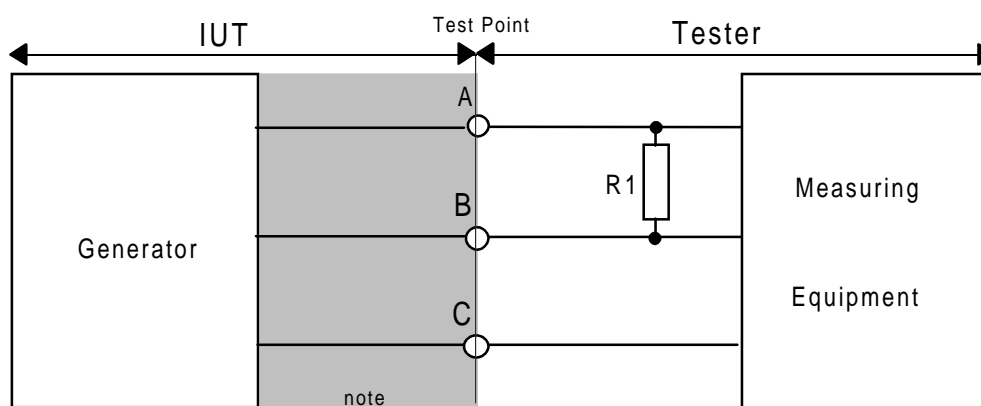

NOTE: This area denotes an interconnection means e.g. interface cable and connector.

Figure 7

IUT interface state:

The IUT shall be powered.

Test stimulus & action:

The IUT is stimulated to generate each of the binary states for the generator under test. The test shall be repeated for each generator to be tested. The dc. voltage is measured between points A and B, between points A and C, and between points B and C.

Expected results:

The magnitudes of the voltages measured between:

- a) points A and B (V_{o});
- b) points A and C (V_{oa});
- c) points B and C (V_{ob});

shall each be less than or equal to 12,0 V for each binary state.

7.5 Test descriptions for attachment to ITU-T Recommendation V.12 interchange circuits

7.5.1 Generator characteristics

7.5.1.1 Generator open circuit output voltage

Test purpose:

This test is to demonstrate compliance with the requirements of subclause 6.3.3.1.

Test considerations:

This test is most easily performed using signals that do not make transitions from one binary state to another while measurement is in progress. However, these tests may be carried out using signal patterns which the terminal is capable of generating. In this case the effects of transient signal conditions shall be disregarded.

Test configuration:

A device for measuring dc voltage is connected across points A and C.

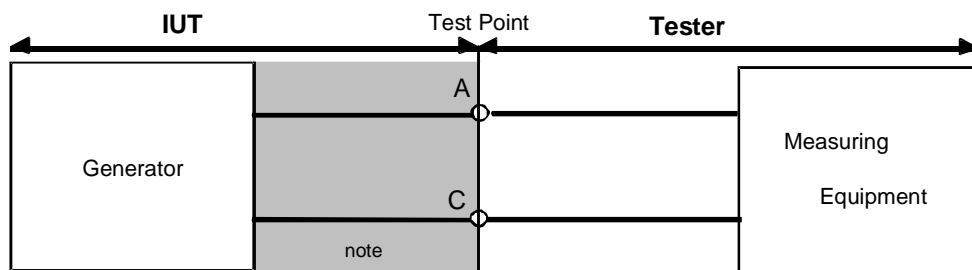

NOTE: The shaded area denotes an interconnection means e.g. interface cable and connector.

Figure 8

IUT interface state:

The IUT shall be powered.

Test stimulus and action:

The IUT is stimulated to generate each of the binary states for the generator under test. The test shall be repeated for each generator to be tested.

Expected results:

The magnitude of the voltage measured between points A and C, shall be less than or equal to 1,5 V for each binary state.

7.6 Test descriptions for attachment to ITU-T Recommendation V.28 interchange circuits

7.6.1 Generator characteristics

7.6.1.1 Generator open circuit output voltage

Test purpose:

This test is to demonstrate compliance with the requirements of subclause 6.3.4.1.

Test considerations:

This test is most easily performed using signals that do not make transitions from one binary state to another while measurement is in progress. However, these tests may be carried out using signal patterns which the terminal is capable of generating. In this case the effects of transient signal conditions shall be disregarded.

Test configuration:

A device for measuring dc voltage is connected across points A and C.

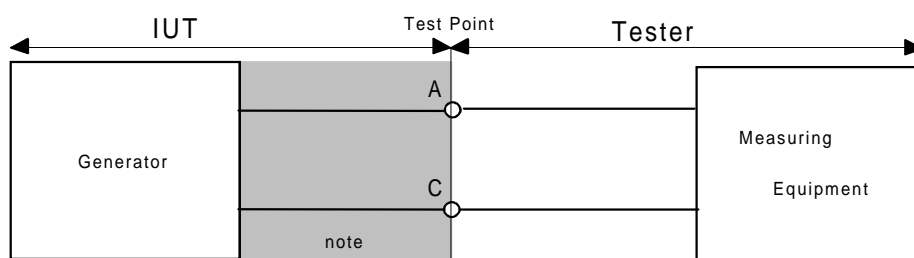

NOTE: The shaded area denotes an interconnection means e.g. interface cable and connector.

Figure 9

IUT interface state:

The IUT shall be powered.

Test stimulus and action:

The IUT is stimulated to generate each of the binary states for the generator under test. The test shall be repeated for each generator to be tested.

Expected results:

The magnitude of the voltage measured between points A and C, shall be less than or equal to 25,0 V for each binary state.

7.7 Test descriptions for attachment to CCITT Recommendation V.35 interchange circuits

7.7.1 Generator characteristics

7.7.1.1 Generator open circuit output voltage

Test purpose:

This test is to demonstrate compliance with the requirements of subclause 6.3.5.1.

Test considerations:

This test is most easily performed using signals that do not make transitions from one binary state to another while measurement is in progress. However, these tests may be carried out using signal patterns which the terminal is capable of generating. In this case the effects of transient signal conditions shall be disregarded.

Test Configuration:

- a) A 3 900 Ω non-reactive impedance (R1) is connected between points A and B. A device for measuring dc. voltage (V_o) is connected between points A and B.
- b) A 3 900 Ω non-reactive impedance (R1) is connected between points A and B. A device for measuring dc. voltage (V_{oa}) is connected between points A and C.
- c) A 3 900 Ω non-reactive impedance (R1) is connected between points A and B. A device for measuring dc. voltage (V_{ob}) is connected between points B and C.

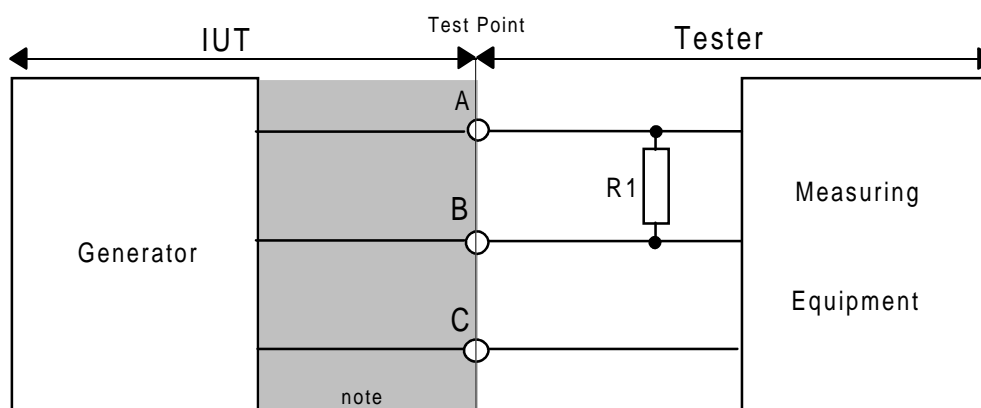

NOTE: This area denotes an interconnection means e.g. interface cable and connector.

Figure 10

IUT interface state:

The IUT shall be powered.

Test stimulus & action:

The IUT is stimulated to generate each of the binary states for the generator under test. The test shall be repeated for each generator to be tested. The dc. voltage is measured between points A and B, between points A and C, and between points B and C.

Expected results:

The magnitudes of the voltages measured between:

- a) points A and B (V_{o});
- b) points A and C (V_{oa});
- c) points B and C (V_{ob});

shall each be less than or equal to 1,2 V for each binary state.

7.8 Test case selection expression definition table

The test case selection expression definition table defines the selection expressions used in selecting the relevant test groups and test cases to be performed for a given implementation to assess conformance with the present document.

The Expression Name is a short form notation used in the Test Case Index Table to express the selection criteria for the different test groups and test cases.

The Selection Expression is a boolean expression which shall be evaluated in terms of the support answers given for individual RT entries, expressed by the relevant entry number.

Table 1: Test Case Selection Expression Definitions

Expression Name	Selection Expression	Comments
15p	if RT 4.1.5 then TRUE ELSE n/a	15-pole connector
25p	if RT 4.1.1 then TRUE ELSE n/a	25-pole connector
26p	if RT 4.1.2 then TRUE ELSE n/a	26-pole connector
26p1	if RT 4.3.1.1 then TRUE ELSE n/a	26-pole connector-connection to ITU-T Recommendation V.10 [10]/V.11 [11] DCE
26p2	if RT 4.3.1.2 then TRUE ELSE n/a	26-pole connector - connection to ITU-T Recommendation V.28 [14] DCE
34p	if RT 4.1.4 then TRUE ELSE n/a	34-pole connector
37p	if RT 4.1.3 then TRUE ELSE n/a	37-pole connector
50p	if RT 4.1.6 then TRUE ELSE n/a	50-pole connector
v10g	if c29=m OR c61=m OR c76=m OR c88=m then TRUE ELSE n/a	Generators for connection to DCE ITU-T Recommendation V.10 [10] receivers, including those circuits forming part of a V.36 [16] interface.
v11g	if c30=m OR c60=m OR c75=m OR c87=m then TRUE ELSE n/a	Generators for connection to DCE ITU-T Recommendation V.11 [11] receivers, including those circuits forming part of a V.36 [16] interface.
v12g	if c100=m then TRUE ELSE n/a	Generators for connection to DCE ITU-T Recommendation V.12 [12] receivers
v28g	if c14=m OR c44=m OR c78=m then TRUE ELSE n/a	Generators for connection to DCE ITU-T Recommendation V.28 [14] receivers
v35g	if c77=m then TRUE ELSE n/a	Generators for connection to DCE CCITT Recommendation V.35 [15] receivers

7.9 Test case Index

Table 2: Test Case Index Table for connector characteristics and contact number assignments

Test Group Reference	Test Case Id.	Selection Ref.	Description
Connector characteristics	7.2.1.1	25p	25-pole connector
Contact number assignments	7.2.1.2	25p	
Connector characteristics	7.2.2.1	26p	26-pole connector
Contact number assignments	7.2.2.2.1	26p1	
Contact number assignments	7.2.2.2.2	26p2	
Connector characteristics	7.2.3.1	37p	37-pole connector
Contact number assignments	7.2.3.2	37p	
Connector characteristics	7.2.4.1	34p	34-pole connector
Contact number assignments	7.2.4.2	34p	
Connector characteristics	7.2.5.1	15p	15-pole connector
Contact number assignments	7.2.5.2	15p	
Connector characteristics	7.2.6.1	50p	50-pole connector
Contact number assignments	7.2.6.2	50p	

Table 3: Test Case Index Table for DTE declared as intended for connection to DCE interchange circuits conforming to ITU-T Recommendation V.10 [10], including those circuits forming part of a V.36 [16] interface

Test Group Reference	Test Case Id.	Selection Ref.	Description
Generator characteristics	7.3.1.1	v10g	Generator open circuit output voltage

Table 4: Test Case Index Table for DTE declared as intended for connection to DCE interchange circuits conforming to ITU-T Recommendation V.11 [11], including those circuits forming part of a V.36 [16] interface

Test Group Reference	Test Case Id.	Selection Ref.	Description
Generator characteristics	7.4.1.1	v11g	Generator open circuit output voltage

Table 5: Test Case Index Table for DTE declared as intended for connection to DCE interchange circuits conforming to ITU-T Recommendation V.12 [12]

Test Group Reference	Test Case Id.	Selection Ref.	Description
Generator characteristics	7.5.1.1	v12g	Generator open circuit output voltage

Table 6: Test Case Index Table for DTE declared as intended for connection to DCE interchange circuits conforming to ITU-T Recommendation V.28 [14]

Test Group Reference	Test Case Id.	Selection Ref.	Description
Generator characteristics	7.6.1.1	v28g	Generator open circuit output voltage

Table 7: Test Case Index Table for DTE declared as intended for connection to DCE interchange circuits conforming to CCITT Recommendation V.35 [15]

Test Group Reference	Test Case Id.	Selection Ref.	Description
Generator characteristics	7.7.1.1	v35g	Generator open circuit output voltage

Annex A (normative): The Requirements Table (RT)

Notwithstanding the provisions of the copyright clause related to the text of the present document, ETSI grants that users of the present document may freely reproduce the RT proforma in this annex so that it can be used for its intended purposes and may further publish the completed RT.

A.1 Introduction to the RT

This RT provides a summary of all the requirements of the present document. It shows the status of each requirement, whether it is essential to implement in all circumstances, or whether the requirement is dependant on the manufacturer having chosen to support a particular optional service or functionality. In particular it enables the Harmonized Standard requirements associated with a particular optional service or functionality to be grouped and identified.

The proforma provides the means to capture the choices which the manufacturer has made in implementing the equipment.

When completed in respect of a particular equipment it provides a means to undertake the Static Assessment of conformity with the Harmonized Standard, and to select the appropriate test cases to be used in dynamically testing the equipment.

A.2 Format of the tables

In the "No." column a local entry number for the requirement in the RT is given. This entry number is further used for the evaluation of the boolean expressions in other parts of the RT and in the Test Case selection expression definition table of the Harmonized Standard.

In the "Cat." column the class of essential requirements is indicated. Essential requirements are classified according to article 5 of Council Directive, 98/13/EEC [3]. The only valid entry used in this RT is D, corresponding to "Protection of public networks".

The "Ref." column references the corresponding requirement subclause of the Harmonized Standard.

In the "Requirement" column a short non-exhaustive description of the requirement is found.

In the "Status" column the status of the entry, as further detailed in the following clause, is indicated.

A.3 Notations used in the RT

A.3.1 Status notations

The "Status" column shows the status of the entries as follows:

- m= Mandatory: shall be implemented under all circumstances.
- o= Optional: may be provided, but if provided shall be implemented in accordance with the requirements.
- o<n>= This status is used for mutually exclusive or selectable options among a set, in cases where it is mandatory to implement one or more options among a set. The integer <n> refers to a unique group of options within the RT. A footnote under the table in which it is used states explicitly what the requirement is for each numbered group.
- c<n>= Conditional number <n>: Reference is made to a boolean expression under the table with predicates of support answers, which will resolve to either "m", "x", or "o<n>" for a specific implementation. In all cases "ELSE Not Applicable" is implied, if an ELSE expression is omitted.
- x= Excluded: This notation is relevant in the case of the contact number assignments, where the specified poles only are permitted to be used as described.

A.3.2 Support answer notations

The "Support" column is reserved for completion in respect of a particular implementation.

- Yes (or Y or y) Indicating that the implementation claims to fully implement the Requirement in accordance with the specification. The entry of a "Yes" against an "x" status entry means the equipment does not conform to the Harmonized Standard.
- No (or N or n) Indicating that the implementation does not claim full support of the Requirement in accordance with the specification. The entry of a "No" against an "m" status entry means the equipment does not conform to the Harmonized Standard.

A.4 The Harmonized Standard Requirement Tables

A.4.1 Means of connection to the DCE

Table A.1: Connector type assignment for DTE intended for connection to a DCE presenting ITU-T Recommendation V series electrical characteristics

Reference:					
No.	Cat.	Ref.	Requirement	Status	Support
4.1.1	D	6.2.1.1	ISO 2110 (25-pole) connector	o.1	
4.1.2	D	6.2.2.1	ISO/IEC 11569 (26-pole) connector	o.1	
4.1.3	D	6.2.3.1	ISO 4902 (37-pole) connector	o.1	
4.1.4	D	6.2.4.1	ISO 2593 (34-pole) connector	o.1	
4.1.5	D	6.2.5.1	ISO 4903 (15-pole) connector	o.1	
4.1.6	D	6.2.6.1	TIA/EIA-613 (50-pole) connector	o.1	
4.1.7	D	6.2	Manufacturers proprietary connector	o.1	

o.1: One or more options shall be chosen

A.4.2 Connection to a DCE presenting an ISO 2110 (25-pole) connector

Table A.2: Use of interchange circuits on DTE intended for connection to a DCE presenting ITU-T Recommendation V.28 [14] electrical characteristics on an ISO 2110 [5] (25-pole) connector

Prerequisite: 4.1.1 - ISO 2110 (25-pole connector)					
Reference:					
No.	Cat.	Ref.	Requirement	Status	Support
4.2.1.1	D	6.2.1.2	Circuit 102 - Signal ground or common return	O	
4.2.1.2	D	6.2.1.2	Circuit 103 - Transmitted data	O	
4.2.1.3	D	6.2.1.2	Circuit 104 - Received data	O	
4.2.1.4	D	6.2.1.2	Circuit 105 - Request to send	O	
4.2.1.5	D	6.2.1.2	Circuit 106 - Ready for sending	O	
4.2.1.6	D	6.2.1.2	Circuit 107 - Data set ready	O	
4.2.1.7	D	6.2.1.2	Circuit 108/1 - Connect data set to line	O	
4.2.1.8	D	6.2.1.2	Circuit 109 - Data channel received line signal detector	O	
4.2.1.9	D	6.2.1.2	Circuit 114 - Transmitter signal element timing (DCE)	O	
4.2.1.10	D	6.2.1.2	Circuit 115 - Receiver signal element timing (DCE)	O	
4.2.1.11	D	6.2.1.2	Circuit 140 - Loopback/Maintenance	O	
4.2.1.12	D	6.2.1.2	Circuit 141 - Local loop back	O	
4.2.1.13	D	6.2.1.2	Circuit 142 - Test indicator	O	

Table A.3: Connector type and contact number assignments for DTE intended for connection to a DCE presenting ITU-T Recommendation V.28 [14] electrical characteristics on an ISO 2110 [5] (25-pole) connector

Prerequisite: 4.1.1 - ISO 2110 (25-pole connector)					
Reference:					
No.	Cat.	Ref.	Requirement	Status	Support
4.2.2.1	D	6.2.1.1	ISO 2110 connector	M	
4.2.2.2	D	6.2.1.2	Signal ground or common return on pole 7	c1	
4.2.2.3	D	6.2.1.2	Transmitted data on pole 2	c2	
4.2.2.4	D	6.2.1.2	Received data on pole 3	c3	
4.2.2.5	D	6.2.1.2	Request to send on pole 4	c4	
4.2.2.6	D	6.2.1.2	Ready for sending on pole 5	c5	
4.2.2.7	D	6.2.1.2	Data set ready on pole 6	c6	
4.2.2.8	D	6.2.1.2	Connect data set to line on pole 20	c7	
4.2.2.9	D	6.2.1.2	Data channel received line signal detector on pole 8	c8	
4.2.2.10	D	6.2.1.2	Transmitter signal element timing (DCE) on pole 15	c9	
4.2.2.11	D	6.2.1.2	Receiver signal element timing (DCE) on pole 17	c10	
4.2.2.12	D	6.2.1.2	Loopback/Maintenance on pole 21	c11	
4.2.2.13	D	6.2.1.2	Local loop back on pole 18	c12	
4.2.2.14	D	6.2.1.2	Test indicator on pole 25	c13	
c1: IF 4.2.1.1 THEN m ELSE x			c8: IF 4.2.1.8 THEN m ELSE x		
c2: IF 4.2.1.2 THEN m ELSE x			c9: IF 4.2.1.9 THEN m ELSE x		
c3: IF 4.2.1.3 THEN m ELSE x			c10: IF 4.2.1.10 THEN m ELSE x		
c4: IF 4.2.1.4 THEN m ELSE x			c11: IF 4.2.1.11 THEN m ELSE x		
c5: IF 4.2.1.5 THEN m ELSE x			c12: IF 4.2.1.12 THEN m ELSE x		
c6: IF 4.2.1.6 THEN m ELSE x			c13: IF 4.2.1.13 THEN m ELSE x		
c7: IF 4.2.1.7 THEN m ELSE x					

Table A.4: Generator electrical characteristics for DTE intended for connection to a DCE presenting ITU-T Recommendation V.28 [14] electrical characteristics on an ISO 2110 [5] (25-pole) connector

Prerequisite: 4.1.1 - ISO 2110 (25-pole connector)					
Reference:					
No.	Cat.	Ref.	Requirement	Status	Support
4.2.3.1	D	6.3.4.1	Generator open circuit output voltage	c14	
c14: IF 4.2.1.2 OR 4.2.1.4 OR 4.2.1.7 OR 4.2.1.11 OR 4.2.1.12 THEN m ELSE n/a					

A.4.3 Connection to a DCE presenting an ISO/IEC 11569 (26-pole) connector

Table A.5: Type of DTE with ISO/IEC 11569 [9] (26-pole) connector which the DTE is intended for connection

Prerequisite: 4.1.2 - ISO/IEC 11569 (26-pole connector)					
Reference:					
No.	Cat.	Ref.	Requirement	Status	Support
4.3.1.1	D	6.2.2.1	Intended for connection to DCE presenting V.10 [10] or V.11 [11] electrical characteristics	o.1	
4.3.1.2	D	6.2.2.1	Intended for connection to DCE presenting V.28 [14] electrical characteristics	o.1	
o.1: One or more options shall be chosen					

Table A.6: Use of Interchange circuits on DTE intended for connection to a DCE presenting ITU-T Recommendation V.10 [10] or V.11 [11] electrical characteristics on an ISO/IEC 11569 [9] (26-pole) connector

Prerequisite: 4.3.1.1 - ISO/IEC 11569 (26-pole connector) intended for connection to V.10 [10]/V.11 [11] DCE					
Reference:					
No.	Cat.	Ref.	Requirement	Status	Support
4.3.2.1	D	6.2.2.2	Circuit 102 - Signal ground or common return	o	
4.3.2.2	D	6.2.2.2	Circuit 103 - Transmitted data	o	
4.3.2.3	D	6.2.2.2	Circuit 104 - Received data	o	
4.3.2.4	D	6.2.2.2	Circuit 105 - Request to send	o	
4.3.2.5	D	6.2.2.2	Circuit 106 - Ready for sending	o	
4.3.2.6	D	6.2.2.2	Circuit 107 - Data set ready	o	
4.3.2.7	D	6.2.2.2	Circuit 108/1 - Connect data set to line or Circuit 108/2 - Data Terminal Ready	o	
4.3.2.8	D	6.2.2.2	Circuit 109 - Data channel received line signal detector	o	
4.3.2.9	D	6.2.2.2	Circuit 114 - Transmitter signal element timing (DCE)	o	
4.3.2.10	D	6.2.2.2	Circuit 115 - Receiver signal element timing (DCE)	o	
4.3.2.11	D	6.2.2.2	Circuit 140 - Loopback/Maintenance	o	
4.3.2.12	D	6.2.2.2	Circuit 141 - Local loop back	o	
4.3.2.13	D	6.2.2.2	Circuit 142 - Test indicator	o	

Table A.7: Connector type and contact number assignments for DTE intended for connection to a DCE presenting ITU-T Recommendation V.10 [10] or V.11 [11] electrical characteristics on an ISO/IEC 11569 [9] (26-pole) connector

Prerequisite: 4.3.1.1 - ISO/IEC 11569 (26-pole connector) intended for connection to V.10 [10]/V.11 [11] DCE					
Reference:					
No.	Cat.	Ref.	Requirement	Status	Support
4.3.3.1	D	6.2.2.1	ISO/IEC 11569 connector	m	
4.3.3.2	D	6.2.2.2	DTE common return A-wire on pole 7	c16	
4.3.3.3	D	6.2.2.2	DCE common return B-wire on pole 23	c16 (note)	
4.3.3.4	D	6.2.2.2	Transmitted data A-wire on pole 2	c17	
4.3.3.5	D	6.2.2.2	Transmitted data B-wire on pole 14	c17 (note)	
4.3.3.6	D	6.2.2.2	Received data A-wire on pole 3	c18	
4.3.3.7	D	6.2.2.2	Received data B-wire on pole 16	c18 (note)	
4.3.3.8	D	6.2.2.2	Request to send A-wire on pole 4	c19	
4.3.3.9	D	6.2.2.2	Request to send B-wire on pole 19	c19 (note)	
4.3.3.10	D	6.2.2.2	Ready for sending A-wire on pole 5	c20	
4.3.3.11	D	6.2.2.2	Ready for sending B-wire on pole 13	c20 (note)	
4.3.3.12	D	6.2.2.2	Data set ready A-wire on pole 6	c21	
4.3.3.13	D	6.2.2.2	Data set ready B-wire on pole 22	c21 (note)	
4.3.3.14	D	6.2.2.2	Connect data set to line or Data terminal ready on pole 20	c22	
4.3.3.15	D	6.2.2.2	Data channel received line signal detector A-wire on pole 8	c23	
4.3.3.16	D	6.2.2.2	Data channel received line signal detector B-wire on pole 10	c23 (note)	
4.3.3.17	D	6.2.2.2	Transmitter signal element timing (DCE) A-wire on pole 15	c24	
4.3.3.18	D	6.2.2.2	Transmitter signal element timing (DCE) B-wire on pole 12	c24 (note)	
4.3.3.19	D	6.2.2.2	Receiver signal element timing (DCE) A-wire on pole 17	c25	
4.3.3.20	D	6.2.2.2	Receiver signal element timing (DCE) B-wire on pole 9	c25 (note)	
4.3.3.21	D	6.2.2.2	Circuit 140 - Loopback/Maintenance on pole 21	c26	
4.3.3.22	D	6.2.2.2	Circuit 141 - Local loop back on pole 18	c27	
4.3.3.23	D	6.2.2.2	Circuit 142 - Test indicator on pole 25	c28	
c16: IF 4.3.2.1 THEN m ELSE x			c17: IF 4.3.2.2 THEN m ELSE x		
c18: IF 4.3.2.3 THEN m ELSE x			c19: IF 4.3.2.4 THEN m ELSE x		
c20: IF 4.3.2.5 THEN m ELSE x			c21: IF 4.3.2.6 THEN m ELSE x		
c22: IF 4.3.2.7 THEN m ELSE x			c23: IF 4.3.2.8 THEN m ELSE x		
c24: IF 4.3.2.9 THEN m ELSE x			c25: IF 4.3.2.10 THEN m ELSE x		
c26: IF 4.3.2.11 THEN m ELSE x			c27: IF 4.3.2.12 THEN m ELSE x		
c28: IF 4.3.2.13 THEN m ELSE x					
NOTE: Only applicable for V11 interface.					

Table A.8: Generator electrical characteristics for DTE intended for connection to a DCE presenting ITU-T Recommendation V.10 [10] electrical characteristics on an ISO/IEC 11569 [9] (26-pole) connector

Prerequisite: 4.3.1.1 - ISO/IEC 11569 (26-pole connector) intended for connection to V.10 [10]/V.11 [11] DCE					
Reference:					
No.	Cat.	Ref.	Requirement	Status	Support
4.3.4.1	D	6.3.1.1	Generator output voltage limit	c29	
c29: IF 4.3.2.2 OR 4.3.2.4 OR 4.3.2.7 OR 4.3.2.11 OR 4.3.2.12 THEN m ELSE n/a					

Table A.9: Generator electrical characteristics for DTE intended for connection to a DCE presenting ITU-T Recommendation V.11 [11] electrical characteristics on an ISO/IEC 11569 [9] (26-pole) connector

Prerequisite: 4.3.1.1 - ISO/IEC 11569 (26-pole connector) intended for connection to V.10 [10]/V.11 [11] DCE					
Reference:					
No.	Cat.	Ref.	Requirement	Status	Support
4.3.5.1	D	6.3.2.1	Generator output voltage limit	c30	
c30: IF 4.3.2.2 OR 4.3.2.4 OR 4.3.2.7 OR 4.3.2.11 OR 4.3.2.12 THEN m ELSE n/a					

Table A.10: Use of Interchange circuits on DTE intended for connection to a DCE presenting ITU-T Recommendation V.28 [14] electrical characteristics on an ISO/IEC 11569 [9] (26-pole) connector

Prerequisite: 4.3.1.2 - ISO/IEC 11569 (26-pole connector) intended for connection to V.28 [14] DCE					
Reference:					
No.	Cat.	Ref.	Requirement	Status	Support
4.3.6.1	D	6.2.2.2	Circuit 102 - Signal ground or common return	o	
4.3.6.2	D	6.2.2.2	Circuit 103 - Transmitted data	o	
4.3.6.3	D	6.2.2.2	Circuit 104 - Received data	o	
4.3.6.4	D	6.2.2.2	Circuit 105 - Request to send	o	
4.3.6.5	D	6.2.2.2	Circuit 106 - Ready for sending	o	
4.3.6.6	D	6.2.2.2	Circuit 107 - Data set ready	o	
4.3.6.7	D	6.2.2.2	Circuit 108/1 - Connect data set to line	o	
4.3.6.8	D	6.2.2.2	Circuit 109 - Data channel received line signal detector	o	
4.3.6.9	D	6.2.2.2	Circuit 114 - Transmitter signal element timing (DCE)	o	
4.3.6.10	D	6.2.2.2	Circuit 115 - Receiver signal element timing (DCE)	o	
4.3.6.11	D	6.2.2.2	Circuit 140 - Loopback/Maintenance	o	
4.3.6.12	D	6.2.2.2	Circuit 141 - Local loop back	o	
4.3.6.13	D	6.2.2.2	Circuit 142 - Test indicator	o	

Table A.11: Connector type and contact number assignments for DTE intended for connection to a DCE presenting ITU-T Recommendation V.28 [14] electrical characteristics on an ISO/IEC 11569 [9] (26-pole) connector

Prerequisite: 4.3.1.2 - ISO/IEC 11569 (26-pole connector) intended for connection to V.28 [14] DCE					
Reference:					
No.	Cat.	Ref.	Requirement	Status	Support
4.3.7.1	D	6.2.2.1	ISO/IEC 11569 connector	m	
4.3.7.2	D	6.2.2.2	Signal ground or common return on pole 7	c31	
4.3.7.3	D	6.2.2.2	Transmitted data on pole 2	c32	
4.3.7.4	D	6.2.2.2	Received data on pole 3	c33	
4.3.7.5	D	6.2.2.2	Request to send on pole 4	c34	
4.3.7.6	D	6.2.2.2	Ready for sending on pole 5	c35	
4.3.7.7	D	6.2.2.2	Data set ready on pole 6	c36	
4.3.7.8	D	6.2.2.2	Connect data set to line on pole 20	c37	
4.3.7.9	D	6.2.2.2	Data channel received line signal detector on pole 8	c38	
4.3.7.10	D	6.2.2.2	Transmitter signal element timing (DCE) on pole 15	c39	
4.3.7.11	D	6.2.2.2	Receiver signal element timing (DCE) on pole 17	c40	
4.3.7.12	D	6.2.2.2	Loopback/Maintenance on pole 21	c41	
4.3.7.13	D	6.2.2.2	Local loop back on pole 18	c42	
4.3.7.14	D	6.2.2.2	Test indicator on pole 25	c43	
c31: IF 4.3.6.1 THEN m ELSE x c32: IF 4.3.6.2 THEN m ELSE x c33: IF 4.3.6.3 THEN m ELSE x c34: IF 4.3.6.4 THEN m ELSE x c35: IF 4.3.6.5 THEN m ELSE x c36: IF 4.3.6.6 THEN m ELSE x c37: IF 4.3.6.7 THEN m ELSE x c38: IF 4.3.6.8 THEN m ELSE x c39: IF 4.3.6.9 THEN m ELSE x c40: IF 4.3.6.10 THEN m ELSE x c41: IF 4.3.6.11 THEN m ELSE x c42: IF 4.3.6.12 THEN m ELSE x c43: IF 4.3.6.13 THEN m ELSE x					

Table A.12: Generator electrical characteristics for DTE intended for connection to a DCE presenting ITU-T Recommendation V.28 [14] electrical characteristics on an ISO/IEC 11569 [9] (26-pole) connector

Prerequisite: 4.3.1.2 - ISO/IEC 11569 (26-pole connector) intended for connection to V.28 [14] DCE					
Reference:					
No.	Cat.	Ref.	Requirement	Status	Support
4.3.8.1	D	6.3.4.1	Generator open circuit output voltage	c44	
c44: IF 4.3.7.3 OR 4.3.7.5 OR 4.3.7.8 OR 4.3.7.12 OR 4.3.7.13 THEN m ELSE n/a					

A.4.4 Connection to a DCE presenting an ISO 4902 (37-pole) connector

Table A.13: Use of Interchange circuits on DTE intended for connection to a DCE presenting ITU-T Recommendation V.10 [10] or V.11 [11] electrical characteristics, including those circuits forming part of a V.36 [16] interface, on an ISO 4902 [7] (37-pole) connector

Prerequisite: 4.1.3 - ISO 4902 (37-pole connector)					
Reference:					
No.	Cat.	Ref.	Requirement	Status	Support
4.4.1.1	D	6.2.3.2	Circuit 102 - Signal ground or common return	o	
4.4.1.2	D	6.2.3.2	Circuit 102A/B - DTE/DCE common return	o	
4.4.1.3	D	6.2.3.2	Circuit 103 - Transmitted data	o	
4.4.1.4	D	6.2.3.2	Circuit 104 - Received data	o	
4.4.1.5	D	6.2.3.2	Circuit 105 - Request to send	o	
4.4.1.6	D	6.2.3.2	Circuit 106 - Ready for sending	o	
4.4.1.7	D	6.2.3.2	Circuit 107 - Data set ready	o	
4.4.1.8	D	6.2.3.2	Circuit 108/1 - Connect data set to line	o	
4.4.1.9	D	6.2.3.2	Circuit 109 - Data channel received line signal detector	o	
4.4.1.10	D	6.2.3.2	Circuit 113 - Transmitter signal element timing (DTE)	o	
4.4.1.11	D	6.2.3.2	Circuit 114 - Transmitter signal element timing (DCE)	o	
4.4.1.12	D	6.2.3.2	Circuit 115 - Receiver signal element timing (DCE)	o	
4.4.1.13	D	6.2.3.2	Circuit 140 - Loopback/Maintenance	o	
4.4.1.14	D	6.2.3.2	Circuit 141 - Local loop back	o	
4.4.1.15	D	6.2.3.2	Circuit 142 - Test indicator	o	

Table A.14: Connector type and contact number assignments for DTE intended for connection to a DCE presenting ITU-T Recommendation V.10 [10] or V.11 [11] electrical characteristics, including those circuits forming part of a V.36 [16] interface, on an ISO 4902 [7] (37-pole) connector

Prerequisite: 4.1.3 - ISO 4902 (37-pole connector)					
Reference:					
No.	Cat.	Ref.	Requirement	Status	Support
4.4.2.1	D	6.2.3.1	ISO 4902 connector	m	
4.4.2.2	D	6.2.3.2	Signal ground or common return (CT102) on pole 19	c46	
4.4.2.3	D	6.2.3.2	DTE common return (CT102a) on pole 37	c47	
4.4.2.4	D	6.2.3.2	DCE common return (CT102b) on pole 20	c47 (note)	
4.4.2.5	D	6.2.3.2	Transmitted data A-wire on pole 4	c48	
4.4.2.6	D	6.2.3.2	Transmitted data B-wire on pole 22	c48 (note)	
4.4.2.7	D	6.2.3.2	Received data A-wire on pole 6	c49	
4.4.2.8	D	6.2.3.2	Received data B-wire on pole 24	c49 (note)	
4.4.2.9	D	6.2.3.2	Request to send A-wire on pole 7	c50	
4.4.2.10	D	6.2.3.2	Request to send B-wire on pole 25	c50 (note)	
4.4.2.11	D	6.2.3.2	Ready for sending A-wire on pole 9	c51	
4.4.2.12	D	6.2.3.2	Ready for sending B-wire on pole 27	c51 (note)	
4.4.2.13	D	6.2.3.2	Data set ready A-wire on pole 11	c52	
4.4.2.14	D	6.2.3.2	Data set ready B-wire on pole 29	c52 (note)	
4.4.2.15	D	6.2.3.2	Connect data set to line A-wire on pole 12	c53	
4.4.2.16	D	6.2.3.2	Connect data set to line B-wire on pole 30	c53 (note)	
4.4.2.17	D	6.2.3.2	Data channel received line signal detector A-wire on pole 13	c54	
4.4.2.18	D	6.2.3.2	Data channel received line signal detector B-wire on pole 31	c54 (note)	
4.4.2.19	D	6.2.3.2	Transmitter signal element timing (DCE) A-wire on pole 5	c55	
4.4.2.20	D	6.2.3.2	Transmitter signal element timing (DCE) B-wire on pole 23	c55 (note)	
4.4.2.21	D	6.2.3.2	Receiver signal element timing (DCE) A-wire on pole 8	c56	
4.4.2.22	D	6.2.3.2	Receiver signal element timing (DCE) B-wire on pole 26	c56 (note)	
4.4.2.23	D	6.2.3.2	Loopback/Maintenance on pole 14	c57	
4.4.2.24	D	6.2.3.2	Local loop back on pole 10	c58	
4.4.2.25	D	6.2.3.2	Test indicator on pole 18	c59	
4.4.2.26	D	6.2.3.2	Transmitter signal element timing (DTE) A-wire on pole ??	c89	
4.4.2.27	D	6.2.3.2	Transmitter signal element timing (DTE) B-wire on pole ??	c89 (note)	
c46: IF 4.4.2.1 THEN m ELSE x			c47: IF 4.4.1.2 THEN m ELSE x		
c48: IF 4.4.1.3 THEN m ELSE x			c49: IF 4.4.1.4 THEN m ELSE x		
c50: IF 4.4.1.5 THEN m ELSE x			c51: IF 4.4.1.6 THEN m ELSE x		
c52: IF 4.4.1.7 THEN m ELSE x			c53: IF 4.4.1.8 THEN m ELSE x		
c54: IF 4.4.1.9 THEN m ELSE x			c89: IF 4.4.1.10 THEN m ELSE x		
c55: IF 4.4.1.11 THEN m ELSE x			c56: IF 4.4.1.12 THEN m ELSE x		
c57: IF 4.4.1.13 THEN m ELSE x			c58: IF 4.4.1.14 THEN m ELSE x		
c59: IF 4.4.1.15 THEN m ELSE x					
NOTE: Only applicable for V11 interface.					

Table A.15: Generator electrical characteristics for DTE intended for connection to a DCE presenting ITU-T Recommendation V.11 [11] electrical characteristics, including those circuits forming part of a V.36 [16] interface, on an ISO 4902 [7] (37-pole) connector

Prerequisite: 4.1.3 - ISO 4902 (37-pole connector)					
Reference:					
No.	Cat.	Ref.	Requirement	Status	Support
4.4.3.1	D	6.3.2.1	Generator output voltage limit	c60	
c60: IF 4.4.1.3 OR 4.4.1.5 OR 4.4.1.8 OR 4.4.1.13 OR 4.4.1.14 THEN m ELSE n/a					

Table A.16: Generator electrical characteristics for DTE intended for connection to a DCE presenting ITU-T Recommendation V.10 [10] electrical characteristics, including those circuits forming part of a V.36 [16] interface, on an ISO 4902 [7] (37-pole) connector

Prerequisite: 4.1.3 - ISO 4902 (37-pole connector)					
Reference:					
No.	Cat.	Ref.	Requirement	Status	Support
4.4.3.1	D	6.3.1.1	Generator output voltage limit	c61	
c61: IF 4.4.1.3 OR 4.4.1.5 OR 4.4.1.8 OR 4.4.1.13 OR 4.4.1.14 THEN m ELSE n/a					

A.4.5 Connection to a DCE presenting an ISO 2593 (34-pole) connector

Table A.17: Use of Interchange circuits on DTE intended for connection to a DCE presenting ITU-T Recommendations V.10 [10], V.28 [14], V.11 [11], or CCITT Recommendation V.35 [15] electrical characteristics on an ISO 2593 [6] (34-pole) connector

Prerequisite: 4.1.4 - ISO 2593 (34-pole connector)					
Reference:					
No.	Cat.	Ref.	Requirement	Status	Support
4.5.1.1	D	6.2.4.2	Circuit 102 - Signal ground or common return	O	
4.5.1.2	D	6.2.4.2	Circuit 103 - Transmitted data	O	
4.5.1.3	D	6.2.4.2	Circuit 104 - Received data	O	
4.5.1.4	D	6.2.4.2	Circuit 105 - Request to send	O	
4.5.1.5	D	6.2.4.2	Circuit 106 - Ready for sending	O	
4.5.1.6	D	6.2.4.2	Circuit 107 - Data set ready	O	
4.5.1.7	D	6.2.4.2	Circuit 108/1 - Connect data set to line	O	
4.5.1.8	D	6.2.4.2	Circuit 109 - Data channel received line signal detector	O	
4.5.1.9	D	6.2.4.2	Circuit 114 - Transmitter signal element timing (DCE)	O	
4.5.1.10	D	6.2.4.2	Circuit 115 - Receiver signal element timing (DCE)	O	
4.5.1.11	D	6.2.4.2	Circuit 140 - Loopback/Maintenance	O	
4.5.1.12	D	6.2.4.2	Circuit 141 - Local loop back	O	
4.5.1.13	D	6.2.4.2	Circuit 142 - Test indicator	O	

Table A.18: Connector type and contact number assignments for DTE intended for connection to a DCE presenting ITU-T Recommendations V.10 [10], V.28 [14], V.11 [11] or CCITT Recommendation V.35 [15] electrical characteristics on an ISO 2593 [6] (34-pole) connector

Prerequisite: 4.1.4 - ISO 2593 (34-pole connector)					
Reference					
No.	Cat.	Ref.	Requirement	Status	Support
4.5.2.1	D	6.2.4.1	ISO 2593 connector	M	
4.5.2.2	D	6.2.4.2	Signal ground or common return on pole B	c62	
4.5.2.3	D	6.2.4.2	Transmitted data A-wire on pole P	c63	
4.5.2.4	D	6.2.4.2	Transmitted data B-wire on pole S	c63 (note)	
4.5.2.5	D	6.2.4.2	Received data A-wire on pole R	c64	
4.5.2.6	D	6.2.4.2	Received data B-wire on pole T	c64 (note)	
4.5.2.7	D	6.2.4.2	Request to send on pole C	c65	
4.5.2.8	D	6.2.4.2	Ready for sending on pole D	c66	
4.5.2.9	D	6.2.4.2	Data set ready on pole E	c67	
4.5.2.10	D	6.2.4.2	Connect data set to line on pole H	c68	
4.5.2.11	D	6.2.4.2	Data channel received line signal detector on pole F	c69	
4.5.2.12	D	6.2.4.2	Transmitter signal element timing (DCE) A-wire on pole Y	c70	
4.5.2.13	D	6.2.4.2	Transmitter signal element timing (DCE) B-wire on pole AA	c70 (note)	
4.5.2.14	D	6.2.4.2	Receiver signal element timing (DCE) A-wire on pole V	c71	
4.5.2.15	D	6.2.4.2	Receiver signal element timing (DCE) B-wire on pole X	c71 (note)	
4.5.2.16	D	6.2.4.2	Loopback/Maintenance on pole N	c72	
4.5.2.17	D	6.2.4.2	Local loop back on pole L	c73	
4.5.2.18	D	6.2.4.2	Test indicator on pole NN	c74	
c62: IF 4.5.1.1 THEN m ELSE x			c69: IF 4.5.1.8 THEN m ELSE x		
c63: IF 4.5.1.2 THEN m ELSE x			c70: IF 4.5.1.9 THEN m ELSE x		
c64: IF 4.5.1.3 THEN m ELSE x			c71: IF 4.5.1.10 THEN m ELSE x		
c65: IF 4.5.1.4 THEN m ELSE x			c72: IF 4.5.1.11 THEN m ELSE x		
c66: IF 4.5.1.5 THEN m ELSE x			c73: IF 4.5.1.12 THEN m ELSE x		
c67: IF 4.5.1.6 THEN m ELSE x			c74: IF 4.5.1.13 THEN m ELSE x		
c68: IF 4.5.1.7 THEN m ELSE x					
NOTE: Only applicable for V.11 [11] and V.35 [15] interfaces.					

Table A.19: Generator electrical characteristics for DTE intended for connection to a DCE presenting ITU-T Recommendation V.11 [11] electrical characteristics on an ISO 2593 [6] (34-pole) connector

Prerequisite: 4.1.4 - ISO 2593 (34-pole connector)					
Reference:					
No.	Cat.	Ref.	Requirement	Status	Support
4.5.3.1	D	6.3.2.1	Generator output voltage limit	c75	
c75: IF 4.5.1.2 THEN m ELSE n/a					

Table A.20: Generator electrical characteristics for DTE intended for connection to a DCE presenting ITU-T Recommendation V.10 [10] electrical characteristics on an ISO 2593 [6] (34-pole) connector

Prerequisite: 4.1.4 - ISO 2593 (34-pole connector)					
Reference:					
No.	Cat.	Ref.	Requirement	Status	Support
4.5.4.1	D	6.3.1.1	Generator output voltage limit	c76	
c76: IF 4.5.1.4 OR 4.5.1.7 OR 4.5.1.11 OR 4.5.1.12 THEN m ELSE n/a					

Table A.21: Generator electrical characteristics for DTE intended for connection to a DCE presenting CCITT Recommendation V.35 [15] electrical characteristics on an ISO 2593 [6] (34-pole) connector

Prerequisite: 4.1.4 - ISO 2593 (34-pole connector)					
Reference:					
No.	Cat.	Ref.	Requirement	Status	Support
4.5.5.1	D	6.3.5.1	Generator output voltage limit	c77	
c77: IF 4.5.1.2 THEN m ELSE n/a					

Table A.22: Generator electrical characteristics for DTE intended for connection to a DCE presenting ITU-T Recommendation V.28 [14] electrical characteristics on an ISO 2593 [6] (34-pole) connector

Prerequisite: 4.1.4 - ISO 2593 (34-pole connector)					
Reference:					
No.	Cat.	Ref.	Requirement	Status	Support
4.5.6.1	D	6.3.4.1	Generator open circuit output voltage	c78	
c78: IF 4.5.1.4 OR 4.5.1.7 OR 4.5.1.11 OR 4.5.1.12 THEN m ELSE n/a					

A.4.6 Connection to a DCE presenting an ISO 4903 (15-pole) connector

Table A.23: Use of Interchange circuits on DTE intended for connection to a DCE presenting ITU-T Recommendation V.10 [10] or V.11 [11] electrical characteristics on an ISO 4903 [8] (15-pole) connector

Prerequisite: 4.1.5 - ISO 4903 (15-pole connector)					
Reference:					
No.	Cat.	Ref.	Requirement	Status	Support
4.6.1.1	D	6.2.5.2	Circuit G - Signal ground or common return	o	
4.6.1.2	D	6.2.5.2	Circuit T - Transmit	o	
4.6.1.3	D	6.2.5.2	Circuit R - Receive	o	
4.6.1.4	D	6.2.5.2	Circuit C - Control	o	
4.6.1.5	D	6.2.5.2	Circuit I - Indication	o	
4.6.1.6	D	6.2.5.2	Circuit S - Signal Element Timing	o	
4.6.1.7	D	6.2.5.2	Circuit B - Byte Timing	o.1	
4.6.1.8	D	6.2.5.2	Circuit X - DTE Transmit Signal Element Timing	o.1	
o.1: Only one of these options may be implemented and active at the same time.					

Table A.24: Connector type and contact number assignments for DTE intended for connection to a DCE presenting ITU-T Recommendation V.10 [10] or V.11 [11] electrical characteristics on an ISO 4903 [8] (15-pole) connector

Prerequisite: 4.1.5 - ISO 4903 (15-pole connector)					
Reference:					
No.	Cat.	Ref.	Requirement	Status	Support
4.6.2.1	D	6.2.5.1	ISO 4903 connector	m	
4.6.2.2	D	6.2.5.2	Signal ground or common return on pole 8	c80	
4.6.2.3	D	6.2.5.2	Transmit A- wire on pole 2	c81	
4.6.2.4	D	6.2.5.2	Transmit B- wire (for V.11 [11]) or alternately DTE common return on pole 9 (for V.10 [10])	c81	
4.6.2.5	D	6.2.5.2	Receive A-wire on pole 4	c82	
4.6.2.6	D	6.2.5.2	Receive B-wire on pole 11	c82	
4.6.2.7	D	6.2.5.2	Control A-wire on pole 3	c83	
4.6.2.8	D	6.2.5.2	Control B-wire (for V.11 [11]) or alternately DCE common return on pole 10 (for V.10 [10])	c83	
4.6.2.9	D	6.2.5.2	Indication A-wire on pole 5	c84	
4.6.2.10	D	6.2.5.2	Indication B-wire on pole 12	c84 (note)	
4.6.2.11	D	6.2.5.2	Signal Element Timing A-wire on pole 6	c85	
4.6.2.12	D	6.2.5.2	Signal Element Timing B-wire on pole 13	c85 (note)	
4.6.2.13	D	6.2.5.2	Byte Timing or DTE Transmit Signal Element Timing on A-wire on pole 7	c86	
4.6.2.14	D	6.2.5.2	Byte Timing or DTE Transmit Signal Element Timing on B-wire on pole 14	c86 (note)	
c80: IF 4.6.1.1 THEN m ELSE x			c84: IF 4.6.1.5 THEN m ELSE x		
c81: IF 4.6.1.2 THEN m ELSE x			c85: IF 4.6.1.6 THEN m ELSE x		
c82: IF 4.6.1.3 THEN m ELSE x			c86: IF 4.6.1.7 OR 4.6.1.8 THEN m ELSE x		
c83: IF 4.6.1.4 THEN m ELSE x					
NOTE: Only applicable for V.11 [11] interface.					

Table A.25: Generator electrical characteristics for DTE intended for connection to a DCE presenting ITU-T Recommendation V.11 [11] electrical characteristics on an ISO 4903 [8] (15-pole) connector

Prerequisite: 4.1.5 - ISO 4903 (15-pole connector)					
Reference:					
No.	Cat.	Ref.	Requirement	Status	Support
4.6.3.1	D	6.3.2.1	Generator output voltage limit	c87	
c87: IF 4.6.1.2 OR 4.6.1.4 OR 4.6.1.8 THEN m ELSE n/a					

Table A.26: Generator electrical characteristics for DTE intended for connection to a DCE presenting ITU-T Recommendation V.10 [10] electrical characteristics on an ISO 4903 [8] (15-pole) connector

Prerequisite: 4.1.5 - ISO 4903 (15-pole connector)					
Reference:					
No.	Cat.	Ref.	Requirement	Status	Support
4.6.4.1	D	6.3.1.1	Generator output voltage limit	c88	
c88: IF 4.6.1.2 OR 4.6.1.4 OR 4.6.1.8 THEN m ELSE n/a					

A.4.7 Connection to a DCE presenting an TIA/EIA-613 (50-pole) connector

Table A.27: Use of Interchange circuits on DTE intended for connection to a DCE presenting ITU-T Recommendation V.12 [12] electrical characteristics on a TIA/EIA-613 [23] (50-pole) connector

Prerequisite: 4.1.6 - TIA/EIA-613 (50-pole connector)					
Reference:					
No.	Cat.	Ref.	Requirement	Status	Support
4.7.1.1	D	6.2.6.2	Circuit 102 - Signal ground or common return	O	
4.7.1.2	D	6.2.6.2	Circuit 103 - Transmitted data	O	
4.7.1.3	D	6.2.6.2	Circuit 104 - Received data	O	
4.7.1.4	D	6.2.6.2	Circuit 107 - DCE ready	O	
4.7.1.5	D	6.2.6.2	Circuit 108/2 - DTE ready	O	
4.7.1.6	D	6.2.6.2	Circuit 113 - Transmitter signal element timing (DTE)	O	
4.7.1.7	D	6.2.6.2	Circuit 114 - Transmitter signal element timing (DCE)	O	
4.7.1.8	D	6.2.6.2	Circuit 115 - Receiver signal element timing (DCE)	O	
4.7.1.9	D	6.2.6.2	Circuit 142 - Test Mode	O	
4.7.1.10	D	6.2.6.2	Circuit 143 - Loopback A	O	
4.7.1.11	D	6.2.6.2	Circuit 144 - Loopback B	O	

Table A.28: Connector type and contact number assignments for DTE intended for connection to a DCE presenting ITU-T Recommendation V.12 [12] electrical characteristics on a TIA/EIA-613 [23] (50-pole) connector

Prerequisite: 4.1.6 - TIA/EIA-613 (50-pole connector)					
Reference:					
No.	Cat.	Ref.	Requirement	Status	Support
4.7.2.1	D	6.2.6.1	TIA/EIA-613 connector	m	
4.7.2.2	D	6.2.6.2	Signal ground or common return on poles 1, 7, 13, 19, 25, 26, 32, 38, 44, 50	c89	
4.7.2.3	D	6.2.6.2	Transmitted data A-wire on pole 11	c90	
4.7.2.4	D	6.2.6.2	Transmitted data B-wire on pole 36	c90	
4.7.2.5	D	6.2.6.2	Received data A-wire on pole 4	c91	
4.7.2.6	D	6.2.6.2	Received data B-wire on pole 29	c91	
4.7.2.7	D	6.2.6.2	DCE ready A-wire on pole 3	c92	
4.7.2.8	D	6.2.6.2	DCE ready B-wire on pole 28	c92	
4.7.2.9	D	6.2.6.2	DTE ready A-wire on pole 8	c93	
4.7.2.10	D	6.2.6.2	DTE ready B-wire on pole 33	c93	
4.7.2.11	D	6.2.6.2	Transmitter signal element timing (DTE) A-wire on pole 9	c94	
4.7.2.12	D	6.2.6.2	Transmitter signal element timing (DTE) B-wire on pole 34	c94	
4.7.2.13	D	6.2.6.2	Transmitter signal element timing (DCE) A-wire on pole 6	c95	
4.7.2.14	D	6.2.6.2	Transmitter signal element timing (DCE) B-wire on pole 31	c95	
4.7.2.15	D	6.2.6.2	Receiver signal element timing (DCE) A-wire on pole 2	c96	
4.7.2.16	D	6.2.6.2	Receiver signal element timing (DCE) B-wire on pole 27	c96	
4.7.2.17	D	6.2.6.2	Test Mode A-wire on pole 24	c97	
4.7.2.18	D	6.2.6.2	Test Mode B-wire on pole 49	c97	
4.7.2.19	D	6.2.6.2	Loopback A A-wire on pole 10	c98	
4.7.2.20	D	6.2.6.2	Loopback A B-wire on pole 35	c98	
4.7.2.21	D	6.2.6.2	Loopback B A-wire on pole 12	c99	
4.7.2.22	D	6.2.6.2	Loopback B B-wire on pole 37	c99	
c89: IF 4.7.1.1 THEN m ELSE x			c95: IF 4.7.1.7 THEN m ELSE x		
c90: IF 4.7.1.2 THEN m ELSE x			c96: IF 4.7.1.8 THEN m ELSE x		
c91: IF 4.7.1.3 THEN m ELSE x			c97: IF 4.7.1.9 THEN m ELSE x		
c92: IF 4.7.1.4 THEN m ELSE x			c98: IF 4.7.1.10 THEN m ELSE x		
c93: IF 4.7.1.5 THEN m ELSE x			c99: IF 4.7.1.11 THEN m ELSE x		
c94: IF 4.7.1.6 THEN m ELSE x					

Table A.29: Generator electrical characteristics for DTE intended for connection to a DCE presenting ITU-T Recommendation V.12 [12] electrical characteristics on a TIA/EIA-613 [23] (50-pole) connector

Prerequisite: 4.1.6 - TIA/EIA-613 (50-pole connector)					
Reference:					
No.	Cat.	Ref.	Requirement	Status	Support
4.7.3.1	D	6.3.3.1	Generator output voltage limit	c100	
c100: IF 4.7.1.2 OR 4.7.1.5 OR 4.7.1.10 OR 4.7.1.11 THEN m ELSE n/a					

Annex B (normative): Physical layer implementation extra information for testing (PIXIT)

Notwithstanding the provisions of the copyright clause related to the text of the present document, ETSI grants that users of the present document may freely reproduce the PIXIT proforma in this annex so that it can be used for its intended purposes and may further publish the completed PIXIT.

Table B.1: Generators that are held in a steady state in normal operation

Generators that are held in a steady state				
Item No.	Ref. to RT	Interface connector type	Pin No.	Comment

Table B.2: Client's additional information on interface circuits

Client's additional information on interface circuits	
Item No.	List of appended information (e.g. circuit diagrams, component specifications, identically implemented interchange circuits)

Table B.3: Client's additional general information

Client's additional general information	
Item No.	Justifications, statements, clarifications etc.

Bibliography

The following material, though not specifically referenced in the body of the present document (or not publicly available), gives supporting information.

- NET 2 (1988): "Approval requirements for data terminal equipment to connect to packet switched public data networks using ITU-T Recommendation X.25, and interface".
- EN 60950 (1992): "Safety of information technology equipment including electrical business equipment".
- ITU-T Recommendation X.1 (1996): "International user classes of service in public data network and integrated services digital networks (ISDNs)".
- TBR 1 (1995): "Terminal Equipment (TE); Attachment requirements for terminal equipment to be connected to circuit switched data networks and leased circuits using a CCITT Recommendation X.21 interface, or at an interface physically, functionally and electrically compatible with CCITT Recommendation X.21 but operating at any data signalling rate up to, and including, 1 984 kbit/s".
- TBR 2 (1997): "Digital Terminals and Access (DTA); Attachment requirements for Data Terminal Equipment (DTE) to connect to Packet Switched Public Data Networks (PSPDNs) for CCITT Recommendation X.25 interfaces at data signalling rates up to 1 920 kbit/s utilizing interfaces derived from CCITT Recommendations X.21 and X.21 bis".

History

Document history				
V1.2.4	February 1999	Public Enquiry	PE 9924:	1999-02-12 to 1999-06-11
V1.2.5	August 1999	Vote	V 9944:	1999-08-17 to 1999-10-15
V1.2.6	October 1999	Publication		