

Draft **ETSI EN 301 248** V4.1.0 (1999-12)

---

*European Standard (Telecommunications series)*

**Digital cellular telecommunications system (Phase 2);  
Discontinuous Transmission (DTX) for Enhanced  
Full Rate (EFR) speech traffic channels  
(GSM 06.81 version 4.1.0)**

---



**GSM**®  
GLOBAL SYSTEM FOR  
MOBILE COMMUNICATIONS

**ETSI** 

---

Reference

---

REN/SMG-110681PR1 (bk0020c0.PDF)

Keywords

---

Digital cellular telecommunications system,  
Global System for Mobile communications (GSM)

**ETSI**

Postal address

---

F-06921 Sophia Antipolis Cedex - FRANCE

Office address

---

650 Route des Lucioles - Sophia Antipolis  
Valbonne - FRANCE  
Tel.: +33 4 92 94 42 00 Fax: +33 4 93 65 47 16  
Siret N° 348 623 562 00017 - NAF 742 C  
Association à but non lucratif enregistrée à la  
Sous-Préfecture de Grasse (06) N° 7803/88

Internet

---

secretariat@etsi.fr  
Individual copies of this ETSI deliverable  
can be downloaded from  
<http://www.etsi.org>  
If you find errors in the present document, send your  
comment to: editor@etsi.fr

**Important notice**

---

This ETSI deliverable may be made available in more than one electronic version or in print. In any case of existing or perceived difference in contents between such versions, the reference version is the Portable Document Format (PDF). In case of dispute, the reference should be the printing on ETSI printers of the PDF version kept on a specific network drive within ETSI Secretariat.

**Copyright Notification**

---

No part may be reproduced except as authorized by written permission.  
The copyright and the foregoing restriction extend to reproduction in all media.

© European Telecommunications Standards Institute 1999.  
All rights reserved.

---

# Contents

Intellectual Property Rights.....	4
Foreword .....	4
1 Scope.....	5
2 References.....	5
3 Definitions, symbols and abbreviations .....	6
3.1 Definitions .....	6
3.2 Symbols .....	7
3.3 Abbreviations.....	7
4 General.....	7
4.1 General organization.....	7
5 Transmit (TX) side.....	8
5.1 General operation.....	8
5.1.1 Functions of the TX DTX handler.....	8
5.1.2 Functions of the TX Radio Subsystem.....	10
6 Receive (RX) side .....	11
6.1 General operation.....	11
6.1.1 Functions of the RX radio subsystem.....	11
6.1.2 Functions of the RX DTX handler .....	12
<b>Annex A (informative): Change Request History .....</b>	<b>13</b>
History .....	14

---

## Intellectual Property Rights

IPRs essential or potentially essential to the present document may have been declared to ETSI. The information pertaining to these essential IPRs, if any, is publicly available for **ETSI members and non-members**, and can be found in SR 000 314: *"Intellectual Property Rights (IPRs); Essential, or potentially Essential, IPRs notified to ETSI in respect of ETSI standards"*, which is available from the ETSI Secretariat. Latest updates are available on the ETSI Web server (<http://www.etsi.org/ipr>).

Pursuant to the ETSI IPR Policy, no investigation, including IPR searches, has been carried out by ETSI. No guarantee can be given as to the existence of other IPRs not referenced in SR 000 314 (or the updates on the ETSI Web server) which are, or may be, or may become, essential to the present document.

---

## Foreword

This European Standard (Telecommunications series) has been produced by ETSI Technical Committee Special Mobile Group (SMG), and is now submitted for the ETSI standards One-step Approval Procedure.

The present document describes the general baseband operation of Enhanced Full Rate speech traffic channels in the transmitter and in the receiver of GSM Mobile Stations and Base Station Systems during Discontinuous Transmission (DTX) within the digital cellular telecommunications system.

The present document corresponds to GSM technical specification, GSM 06.81, version 4.1.0.

<b>Proposed national transposition dates</b>	
Date of latest announcement of this EN (doa):	3 months after ETSI publication
Date of latest publication of new National Standard or endorsement of this EN (dop/e):	6 months after doa
Date of withdrawal of any conflicting National Standard (dow):	6 months after doa

---

# 1 Scope

The present document gives a description of the general baseband operation of Enhanced Full Rate speech traffic channels in the transmitter and in the receiver of GSM Mobile Stations (MS)s and Base Station Systems (BSS)s during Discontinuous Transmission (DTX).

For clarity, the description is structured according to the block diagrams in figures 1 and 4. Except in the case described next, this structure of distributing the various functions between system entities is not mandatory for implementation, as long as the operation on the air interface and on the speech decoder output remains the same.

In the case of BSSs where the speech transcoder is located remotely in the Base Station Controller (BSC), the implementation of the interfaces between the DTX handlers and the Radio Sub System (RSS) as described in the present document together with all their flags is mandatory, being part of the A-bis interface as described in GSM 08.60 (ETS 300 737) [13].

The DTX functions described in the present document are mandatory for implementation in the GSM MSs. The receiver requirements are mandatory for implementation in all GSM BSSs, the transmitter requirements only for those where downlink DTX will be used.

---

# 2 References

The following documents contain provisions which, through reference in this text, constitute provisions of the present document.

- References are either specific (identified by date of publication, edition number, version number, etc.) or non-specific.
- For a specific reference, subsequent revisions do not apply.
- For a non-specific reference, the latest version applies.
- A non-specific reference to an ETS shall also be taken to refer to later versions published as an EN with the same number.

- [1] GSM 01.04 (ETR 100): "Digital cellular telecommunications system (Phase 2); Abbreviations and acronyms".
- [2] GSM 04.08 (ETS 300 557): "Digital cellular telecommunications system (Phase 2); Mobile radio interface layer 3 specification".
- [3] GSM 05.03 (ETS 300 575): "Digital cellular telecommunications system (Phase 2); Channel coding".
- [4] GSM 05.05 (ETS 300 577): "Digital cellular telecommunications system (Phase 2); Radio transmission and reception".
- [5] GSM 05.08 (ETS 300 578): "Digital cellular telecommunications system (Phase 2); Radio subsystem link control".
- [6] GSM 06.51 (EN 301 243): "Digital cellular telecommunications system; Enhanced Full Rate (EFR) speech processing functions; General description".
- [7] GSM 06.53 (EN 301 244): "Digital cellular telecommunications system; ANSI-C code for the GSM Enhanced Full Rate (EFR) speech codec".
- [8] GSM 06.54 (EN 301 250): "Digital cellular telecommunications system (Phase 2); Test vectors for the GSM Enhanced Full Rate (EFR) speech codec".
- [9] GSM 06.60 (EN 301 245): "Digital cellular telecommunications system; Enhanced Full Rate (EFR) speech transcoding".

- [10] GSM 06.61 (EN 301 246): "Digital cellular telecommunications system; Substitution and muting of lost frame for Enhanced Full Rate (EFR) speech traffic channels".
- [11] GSM 06.62 (EN 301 247): "Digital cellular telecommunications system; Comfort noise aspects for Enhanced Full Rate (EFR) speech traffic channels".
- [12] GSM 06.82 (EN 301 249): "Digital cellular telecommunications system; Voice Activity Detector (VAD) for Enhanced Full Rate (EFR) speech traffic channels".
- [13] GSM 08.60 (ETS 300 737): "Digital cellular telecommunications system (Phase 2+); Inband control of remote transcoders and rate adaptors for Enhanced Full Rate (EFR) and full rate traffic channels".

---

## 3 Definitions, symbols and abbreviations

### 3.1 Definitions

For the purposes of the present document, the following terms and definitions apply:

**accepted SID frame:** A traffic frame which is flagged with SID="1" or SID="2" by the Radio Subsystem.

**bad traffic frame:** A traffic frame flagged BFI flag ="1" (Bad Frame Indication) by the Radio Subsystem.

**frame:** Time interval of 20 msec. corresponding to the time segmentation of the Enhanced Full Rate speech transcoder (GSM 06.60 (EN 301 245) [9]), also used as a short term for a traffic frame.

**good speech frame:** A good traffic frame which is not an accepted SID frame.

**good traffic frame:** A traffic frame flagged BFI flag ="0" by the Radio Subsystem.

**hangover period:** A period of 7 frames added at the end of a speech burst in which VAD flag ="0" and SP flag ="1".

**invalid SID frame:** An accepted SID frame which was not classified as valid SID frame. This frame is not valid for updating comfort noise parameters, but the frame conveys information that comfort noise generations should be started or continued.

**lost SID frame:** An unusable frame received when the RX DTX handler is generating comfort noise and a SID frame is expected (Time Alignment Flag, TAF="1").

**lost speech frame:** An unusable frame received when the RX DTX handler is passing on traffic frames directly to the speech decoder.

**SID code word:** Fixed bit pattern defined in GSM 06.62 (EN 301 247) [11], for labelling a traffic frame as a SID frame.

**SID field:** The bit positions defined in GSM 06.62 (EN 301 247) [11], of the SID codeword within a SID frame.

**SID frame:** Frame characterized by the SID (Silence Descriptor) code word. It conveys information on the acoustic background noise.

**SP flag:** Boolean flag, generated by the TX DTX handler, indicating the presence of a speech frame ("1") or the presence of a SID frame ("0").

**speech frame:** Traffic frame that cannot be classified as a SID frame.

**TAF flag:** Time Alignment Flag. Boolean flag, marks with TAF=1 those traffic frames that are aligned with the SACCH multiframe structure (see GSM 05.08 (ETS 300 578) [5]). The next SID frame is expected at the decoder when TAF=1.

**traffic frame:** Block of 244 information bits transmitted on the Enhanced Full Rate speech traffic channel.

**unusable frame:** A bad traffic frame that is not an accepted SID frame.

**VAD flag:** Boolean flag, generated by the VAD algorithm defined in GSM 06.82 (EN 301 249) [12] indicating the presence ("1") or the absence ("0") of a speech frame.

**valid SID frame:** A good traffic frame flagged with SID="2" by the Radio Subsystem. This frame is valid for updating of comfort noise parameters at any time.

## 3.2 Symbols

For the purposes of the present document, the following symbol applies:

$N_{\text{elapsed}}$  Number of elapsed frames since the last updated SID frame.

## 3.3 Abbreviations

For the purposes of the present document, the following abbreviations apply:

BFI	Bad Frame Indicator
BSC	Base Station Controller
BSS	Base Station System
DTX	Discontinuous Transmission
ETS	European Telecommunication Standard
FACCH	Fast Associated Control CHannel
GSM	Global System for Mobile Telecommunications
MS	Mobile Station
RSS	Radio Sub System
RX	Receive
SACCH	Slow Associated Control CHannel
SID	Silence Descriptor
TX	Transmit
VAD	Voice Activity Detector

For abbreviations not given in this subclause, see GSM 01.04 (ETR 100) [1].

---

# 4 General

Discontinuous Transmission (DTX) is a mechanism which allows the radio transmitter to be switched off most of the time during speech pauses for the following two purposes:

- to save power in the Mobile Station (MS);
- to reduce the overall interference level over the air interface;

DTX shall be in operation in GSM MS if commanded so by the network, see GSM 04.08 (ETS 300 557) [2].

## 4.1 General organization

The overall DTX mechanism described in this draft EN requires the following functions:

- a Voice Activity Detector (VAD) on the transmit (TX) side;
- evaluation of the background acoustic noise on the transmit (TX) side, in order to transmit characteristic parameters to the receive (RX) side;
- generation on the receive (RX) side of a similar noise, called comfort noise, during periods where the radio transmission is switched off.

The Voice Activity Detector (VAD) is defined in GSM 06.82 (EN 301 249) [12] and the comfort noise functions in GSM 06.62 (EN 301 247) [11]. Both are based partly on the speech transcoder and its internal variables, defined in GSM 06.60 (EN 301 245) [9].

In addition to these functions, if the parameters arriving at the RX side are detected to be seriously corrupted by errors, the speech or comfort noise must be generated from substituted data in order to avoid seriously annoying effects for the listener. This function is defined in GSM 06.61 (EN 301 246) [10].

An overall description of the speech processing parts can be found in GSM 06.51 (EN 301 243) [6].

## 5 Transmit (TX) side

A block diagram of the transmit side DTX functions is shown in figure 1.

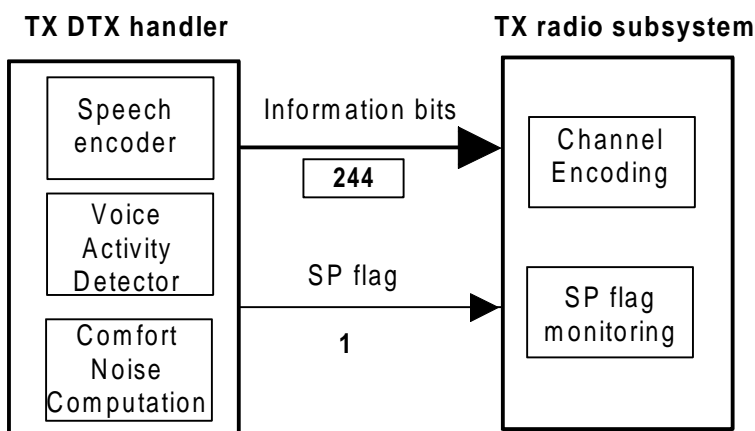

Figure 1: Block diagram of the transmit side DTX functions

### 5.1 General operation

The TX DTX handler continuously passes traffic frames, individually marked by a flag SP, to the Radio Subsystem (RSS). This binary flag is redundant to the SID code word labelling. SP flag = "1" indicates a speech frame, SP flag = "0" a SID frame.

The scheduling of the frames for transmission on the air interface is controlled by the radio subsystem (RSS) alone, on the basis of the SP flag as described in subclause 5.1.1.

#### 5.1.1 Functions of the TX DTX handler

To allow an exact verification of the TX DTX handler functions, all frames before the reset of the system are treated as if there were speech frames of an infinitely long time. Therefore, the first 7 frames after the reset are always marked with SP flag = "1", even if VAD flag = "0" (hangover period, see figure 2).

The Voice Activity Detector (VAD) shall operate all the time in order to assess whether the input signal contains speech or not. The output is a binary flag (VAD flag = "1" or VAD flag = "0", respectively) on a frame by frame basis (see GSM 06.82 (EN 301 249) [12]).

The VAD flag controls indirectly, via the TX DTX handler operations described below, the overall DTX operation on the transmit side.

Whenever VAD flag = "1", the speech encoder output frame shall be passed directly to the radio subsystem (RSS), marked with SP flag = "1".



At the end of a speech burst (transition VAD flag = "1" to VAD flag = "0"), it takes 8 consecutive frames to make a new updated SID frame available (see GSM 06.62 (EN 301 247) [11]). Normally, the first 7 speech encoder output frames after the end of the speech burst shall therefore be passed directly to the radio subsystem, marked with SP flag = "1" ("hangover period"). The first new SID frame is then passed to the RSS as frame 8 after the end of the speech burst, marked with SP flag = "0" (see figure 2).

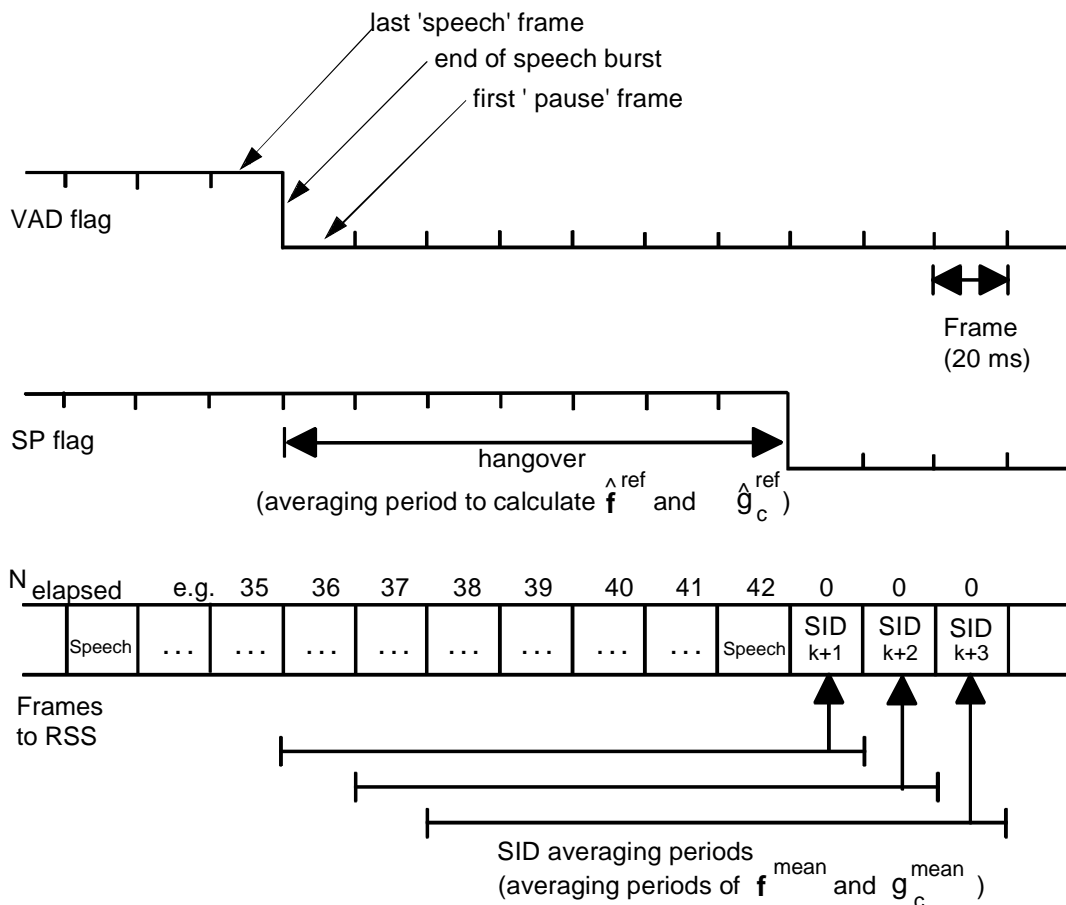

( $N_{elapsed}$ : No. of elapsed frames since last update SID)

**Figure 2: Normal hangover procedure ( $N_{elapsed} > 23$ )**

If, however, at the end of the speech burst, less than 24 frames have elapsed since the last SID frame was computed and passed to the RSS, then this last SID frame shall repeatedly be passed to the RSS, until a new updated SID frame is available (8 consecutive frames marked with VAD flag = "0"). This reduces the activity on the air in cases where short background noise spikes are taken for speech, by avoiding the "hangover" waiting for the SID frame computation (see figure 3).

NOTE: Figure 3 shows as example the longest possible speech burst without hangover.

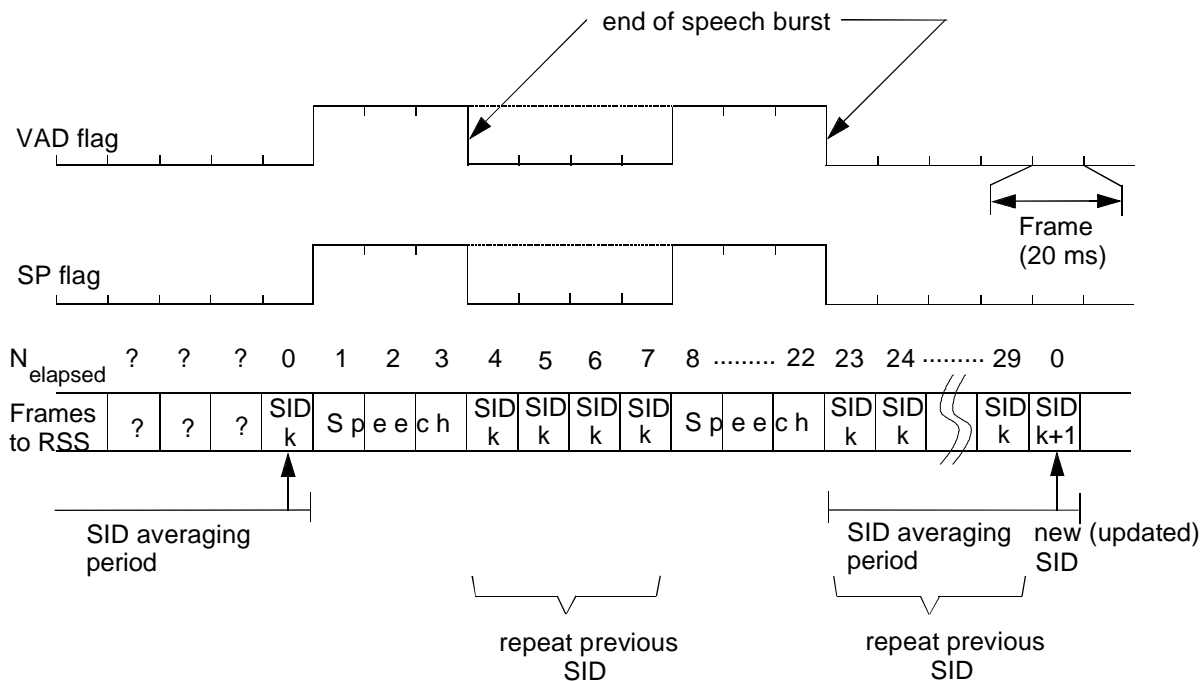

**Figure 3: Handling of short speech bursts ( $N_{elapsd} < 24$ ) (Example)**

Once the first SID frame after the end of a speech burst has been computed and passed to the Radio Subsystem, the TX DTX handler shall continuously compute and pass updated SID frames to the Radio Subsystem (RSS), marked with SP flag = "0" as long as VAD flag = "0".

Following a handover, the DTX hangover period should be initiated in the MS speech encoder to synchronize the encoder and decoder DTX states. This will allow a decoder which is reset at handover to synthesize comfort noise with the correct noise level using the first received SID frame following the handover.

The speech encoder is operated in full speech modality if SP flag = "1" and in a simplified mode if SP flag = "0", because not all encoder functions are required for the evaluation of comfort noise parameters.

### 5.1.2 Functions of the TX Radio Subsystem

The following traffic frames shall be scheduled for transmission:

- all frames marked with SP flag = "1";
- the first one with SP flag = "0" after one or more frames with SP flag = "1";
- those marked with SP=0 and aligned with the SACCH multiframe structure as described in GSM 05.08 (ETS 300 578) [5].

This has the overall function, that the radio transmission is cut after the transmission of a SID frame when the speaker stops talking. During speech pauses the transmission is resumed at regular intervals for transmission of one SID frame, in order to update the generated comfort noise on the RX side (and to improve the measurement of the link quality by the RSS).

If a SID frame (SP flag = "0"), scheduled for transmission is stolen for Fast Associated Control Channel (FACCH) signalling purposes, then the subsequent frame shall be scheduled for transmission instead.

## 6 Receive (RX) side

A block diagram of the receive side DTX functions is shown in figure 4 below.

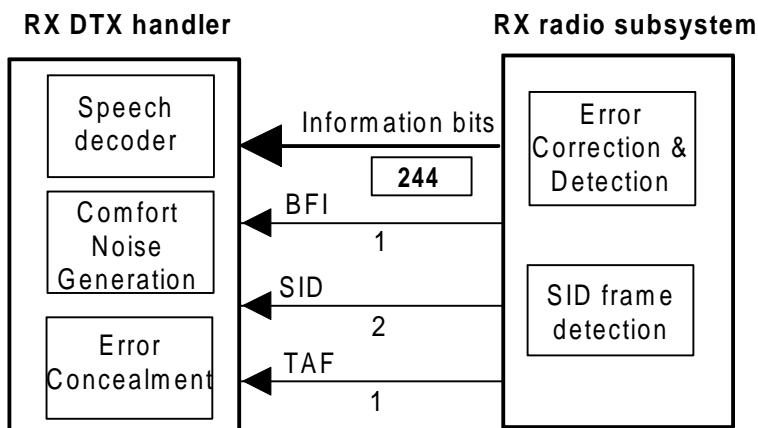

Figure 4: Block diagram of the receive side DTX functions

### 6.1 General operation

Whatever their context (speech, SID, FACCH or none), the RSS continuously passes the received traffic frames to the RX DTX handler, individually marked by various pre-processing functions with 3 flags. These are the Bad Frame Indicator (BFI) flag, the Silence Descriptor (SID) flag and the Time Alignment Flag (TAF) described in subclause 6.1.1 and table 1, which serve to classify the traffic frame according to the list of terms defined in subclause 3.1. This classification, summarized in table 1, allows the RX DTX handler to determine in a simple way how the received frame is to be handled.

Table 1: Classification of traffic frames

		SID		
BFI		2	1	0
0		Valid SID frame		Good speech frame
1		Invalid SID frame		Unusable frame

#### 6.1.1 Functions of the RX radio subsystem

The binary BFI flag (see GSM 05.05 (ETS 300 577) [4]) indicates whether the traffic frame is considered to contain meaningful information bits (BFI flag = "0") or not (BFI flag = "1"). In the context of this EN, a FACCH frame is considered not to contain meaningful bits and shall be marked with BFI flag = "1". The BFI flag must fulfil the performance requirements of GSM 05.05 (ETS 300 577) [4].

The SID frame detector compares bit by bit the relevant bits of the received traffic frame (the SID field) with the SID code word defined in GSM 06.62 (EN 301 247) [11] and gives back the ternary SID flag. The SID flag is coded as follows, where  $n$  designates the number of bit deviations:

$$\text{SID} = 2 \text{ when } n < 2$$

$$\text{SID} = 1 \text{ when } 2 \leq n < 16$$

$$\text{SID} = 0 \text{ when } n \geq 16$$

The binary TAF flag marks with TAF="1" those traffic frames that are aligned with the SACCH multiframe structure as described in GSM 05.08 (ETS 300 578) [5].

## 6.1.2 Functions of the RX DTX handler

The RX DTX handler is responsible for the overall DTX operation on the RX side.

The DTX operation on the RX side shall be as follows:

- whenever a good speech frame is detected, the DTX handler shall pass it directly on to the speech decoder;
- when lost speech or lost SID frames are detected, the substitution and muting procedure defined in GSM 06.61 (EN 301 246) [10] shall be applied;
- valid SID frames shall result in comfort noise generation, as defined in GSM 06.62 (EN 301 247) [11], until the next SID frame is expected (TAF = "1") or good speech frames are detected. During this period, the RX DTX handler shall ignore any unusable frames delivered by the RSS;
- an invalid SID frame shall be substituted by the last valid SID frame and the procedure for valid SID frames be applied.

---

## Annex A (informative): Change Request History

SMG#	Tdoc SMG	Spec	CR	Cat	PH	Vers	New Vers	Subject
s30	631/99	06.81	A003	C	2	4.0.1	4.1.0	Fix of DTX Synchronization Poble m at Handover

---

# History

<b>Document history</b>			
V4.0.0	August 1997	One-step Approval Procedure	OAP 9750: 1997-08-15 to 1997-12-12
V4.0.1	December 1997	Publication	
V4.1.0	December 1999	One-step Approval Procedure	OAP 200013: 1999-12-01 to 2000-03-31