

Draft **EN 301 217-1** V1.1.1 (1998-07)

European Standard (Telecommunications series)

**V interface at the digital Service Node (SN);
Interface at the VB5.2 reference point for the support of
broadband or combined narrowband and broadband
Access Networks (ANs);
Part 1: Interface specification**



Reference

DEN/SPS-03047-1 (b9o90ico.PDF)

Keywords

AN, SN, V5 interface

ETSI

Postal address

F-06921 Sophia Antipolis Cedex - FRANCE

Office address

650 Route des Lucioles - Sophia Antipolis
Valbonne - FRANCE

Tel.: +33 4 92 94 42 00 Fax: +33 4 93 65 47 16

Siret N° 348 623 562 00017 - NAF 742 C
Association à but non lucratif enregistrée à la
Sous-Préfecture de Grasse (06) N° 7803/88

Internet

secretariat@etsi.fr

<http://www.etsi.fr>

<http://www.etsi.org>

Copyright Notification

No part may be reproduced except as authorized by written permission.
The copyright and the foregoing restriction extend to reproduction in all media.

© European Telecommunications Standards Institute 1998.
All rights reserved.

Contents

Intellectual Property Rights.....	10
Foreword	10
Introduction	11
1 Scope.....	12
2 References.....	13
3 Definitions and abbreviations	16
3.1 Definitions	16
3.2 Abbreviations.....	17
4 Field of application	18
5 Introduction to the VB5.2 reference point concept.....	19
5.1 General VB5.2 design principles	19
5.2 General reference model for the VB5.2 reference point	20
5.3 General characteristics of individual functional groups	20
5.3.1 User port function characteristics.....	20
5.3.2 ATM connection function characteristics.....	20
5.3.3 Service port function characteristics	21
5.4 Functional modelling	21
5.4.1 Modelling of user port function.....	21
5.4.2 Modelling of service port function	21
5.4.3 Modelling of ATM connection function	21
5.5 AN view and SN view of physical and logical ports.....	22
6 Procedural interface requirements	22
6.1 Introduction.....	22
6.2 Physical layer requirements	23
6.3 ATM layer requirements.....	23
6.3.1 Cell header format and encoding and pre-assigned cell headers for use by the ATM layer	23
6.3.2 Cell Loss Priority (CLP)	23
6.3.3 VPC carrying RTMC and B-BCC protocol VCCs.....	23
6.3.4 OAM	23
6.4 Higher layer interface requirements	23
6.4.1 User plane	23
6.4.2 Control plane.....	23
6.4.3 Management plane	24
6.4.4 Establishment of VP and VC links/connections	24
6.4.4.1 Establishment of VP links and connections	24
6.4.4.2 Establishment of VC links and VC connections	24
6.4.5 ATM adaptation layer for the RTMC protocol	25
6.4.6 ATM adaptation layer for the B-BCC protocol.....	25
6.4.6.1 General AAL requirements.....	25
6.4.6.2 AAL5 requirements	25
6.4.6.3 SSCOP requirements	25
6.4.6.4 SSCF requirements	26
6.5 Meta-signalling	26
6.6 Interface Management Application	26
6.7 Usage information transfer.....	26
7 Broadband access network connection types.....	26
7.1 Introduction to connections/connection elements	26
7.2 Multipoint requirements.....	26
7.3 Broadband access network connection element identifiers.....	27
7.3.1 Connection element identifiers in user-to-network signalling messages	27
7.3.2 Connection element identifiers in RTMC messages.....	27

7.3.3	Connection element identifiers in B-BCC messages	27
7.4	Overview of broadband access network connection types	28
7.5	B-ISDN type broadband access network connections.....	28
7.5.1	Type A broadband access network connections	28
7.5.2	Type B broadband access network connections	28
7.5.3	Type C broadband access network connections	28
7.5.3.1	Type C-VC broadband access network connections.....	28
7.5.3.2	Application of type C-VC PP broadband AN connection	29
7.6	Non-B-ISDN type broadband access network connections	31
7.6.1	Type D broadband access network connections	31
7.6.2	Type E broadband access network connections	31
7.6.2A	Type E-VC broadband access network connection	31
8	Handling of non-B-ISDN access types	31
8.1	General considerations.....	31
8.2	ATM based accesses.....	31
8.2.1	General approach	31
8.2.2	User plane	32
8.2.3	Control plane.....	32
8.2.4	Management plane	33
8.3	Non-ATM based accesses.....	33
8.3.1	General approach	33
8.3.1.1	User plane.....	33
8.3.1.2	Control plane	34
8.3.1.3	Management plane.....	35
8.3.2	Analogue and 64 kbit/s based narrowband accesses as supported by V5 interfaces	35
8.3.3	Other non-ATM based non-B-ISDN accesses.....	35
9	Transfer and layer management functions	35
9.1	General functional architecture.....	35
9.2	Functional architecture of transfer and layer management functions	38
9.3	Transfer functions required for individual broadband AN connection types	39
9.4	Functions associated with logical and physical ports.....	40
10	Provisioning principles and requirements.....	40
10.1	General.....	40
10.2	Provisioning principles common for the VB5.1 and VB5.2 reference point concept	40
10.3	Provisioning principles specific for the VB5.2 reference point concept.....	40
11	Requirements for real-time co-ordination between AN and SN.....	42
11.1	Principles and requirements for real-time management co-ordination (RTMC).....	42
11.2	Principles and requirements for broadband bearer connection control (B-BCC)	42
11.2.1	General principles for B-BCC.....	42
11.2.2	Establishment of bearer connections	43
11.2.2.1	Selection of VPCI and VCI at the service port	43
11.2.2.2	Selection of VPCI and VCI at the user port.....	44
11.2.2.3	Bearer connection parameters.....	45
11.2.2.4	Negotiation of connection characteristics	45
11.2.2.5	Branches of point-to-multipoint connections	45
11.2.3	Release of bearer connections	46
11.2.4	Modification of traffic parameters of established bearer connections	46
11.2.5	B-BCC reset	46
11.2.6	Automatic congestion control.....	46
11.2.7	B-BCC start-up and B-BCC restart requirements.....	47
11.2.7.1	B-BCC start-up.....	47
11.2.7.2	B-BCC restart	47
11.2.7.3	Indirect initiation of a B-BCC start-up or restart at the AN.....	48
11.2.8	Procedural requirements.....	48
12	Performance design objectives.....	49
12.1	Performance design objectives for transfer functions	49
12.2	Performance design objectives for RTMC and B-BCC functions	49

13	VB5.2 system architecture, structure and procedures.....	49
13.1	Introduction and overview	49
13.2	RTMC system architecture	51
13.3	RTMC procedures	51
13.4	B-BCC system architecture.....	51
13.4.1	System diagrams.....	51
13.4.1.1	Overview of B-BCC system	51
13.4.1.2	Classification of B-BCC primitives	53
13.4.1.3	B-BCC system (AN side)	53
13.4.1.4	B-BCC system (SN side)	55
13.4.1.5	Primitive interface between B-BCC system and the VB5.2 application functions	57
13.4.1.5.1	Primitives common for the AN and SN	57
13.4.1.5.2	Primitives specific for the SN	58
13.4.1.5.3	Primitives specific for AN	60
13.4.1.6	Primitive interface between B-BCC protocol system and ATM adaptation layer	62
13.4.1.7	Description of VB5 B-BCC messages and parameters.....	62
13.4.2	Block diagrams.....	62
13.4.2.1	B-BCC management entities.....	62
13.4.2.2	B-BCC connection management entities	64
13.4.2.3	B-BCC protocol entities	65
13.5	VB5.2 connection control functions	67
13.5.1	General.....	67
13.5.2	Interworking with user signalling.....	68
13.5.2.1	Interworking with DSS2 based signalling systems	68
13.5.2.2	Support of user-to-network signalling systems other than DSS2.....	69
13.5.3	Allocation of VPCI/VCI and bandwidth	69
13.5.3.1	VPCI/VCI selection procedure for the service port.....	69
13.5.3.1.1	VPCI/VCI selection procedure start at the SN.....	69
13.5.3.1.2	VPCI/VCI selection procedure at the AN.....	70
13.5.3.1.3	Selection procedure termination at the SN.....	70
13.5.3.2	VPCI/VCI selection procedure for the user port.....	71
13.5.4	Connection establishment and parameter negotiation	72
13.5.4.1	Connection establishment start in the SN	72
13.5.4.2	Connection establishment start in the AN.....	73
13.5.4.3	Parameter negotiation in the AN.....	73
13.5.4.4	Connection establishment continuation in the SN	74
13.5.4.5	Connection establishment termination in the AN	75
13.5.4.6	Connection establishment termination in the SN.....	75
13.5.5	Release of connections	76
13.5.5.1	Connection release start in the SN.....	76
13.5.5.2	Connection release in the AN.....	76
13.5.5.3	Connection release termination in the SN.....	76
13.5.5.4	Use of en bloc deallocation	77
13.5.6	Modification of traffic parameters.....	77
13.5.6.1	Modification start in the SN	77
13.5.6.2	Modification start in the AN.....	77
13.5.6.3	Progressing modification in the SN	78
13.5.6.4	Modify completion in the AN.....	78
13.5.6.5	Modify terminated at the SN	79
13.5.7	Establishment of branches of point-to-multipoint connections.....	79
13.5.7.1	Branch establishment start in the SN	80
13.5.7.2	Branch establishment start in the AN	80
13.5.7.3	Branch establishment continuation/completion in the SN	80
13.5.7.4	Branch establishment termination in the AN	81
13.5.7.5	Branch establishment termination in the SN.....	82
13.5.8	Release of branches.....	82
13.5.8.1	Branch release start in the SN.....	82
13.5.8.2	Branch release in the AN.....	82
13.5.8.3	Branch release termination in the SN	83
13.5.8.4	Use of en bloc drop branch.....	83

13.5.9	Interworking with ANs not supporting point to multipoint connections	83
13.5.10	AN fault procedure.....	84
13.5.11	B-BCC Reset.....	84
13.5.11.1	B-BCC reset start at the SN	85
13.5.11.2	B-BCC reset at the AN	85
13.5.11.3	B-BCC reset termination in the SN	85
13.5.11.4	Functionality in the AN to report abnormal conditions	85
13.5.12	B-BCC automatic congestion control functions	86
13.5.12.1	Actions taken during overload in the AN	86
13.5.12.2	Receipt of primitives by the SN connection control function containing an automatic congestion level parameter	86
13.5.13	Establishment of (semi-)permanent connections via the B-BCC protocol	86
13.6	B-BCC communication procedures	87
13.6.1	General principles for the B-BCC procedures.....	87
13.6.1.1	Overview of B-BCC communication mechanism	87
13.6.1.2	Acknowledgements.....	88
13.6.1.3	Use of transaction identifiers	88
13.6.1.4	Use of connection reference numbers and branch identifiers	88
13.6.1.5	General error handling	88
13.6.1.5.1	Handling of protocol syntax error conditions.....	88
13.6.1.5.2	Error procedures with explicit action indication	88
13.6.1.5.3	Transmission error in communication with peer network element.....	89
13.6.1.5.4	Procedural B-BCC errors.....	89
13.6.1.5.5	Requested operation rejected by peer network element	89
13.6.1.6	Timers used in B-BCC procedures	89
13.6.1.7	Segmentation of requests into individual transactions	89
13.6.2	Procedures for establishment and release of bearer connections.....	90
13.6.2.1	Bearer connection establishment procedure	90
13.6.2.1.1	General.....	90
13.6.2.1.2	Procedure	90
13.6.2.1.3	Exceptional procedures.....	90
13.6.2.2	Bearer connection release procedure	91
13.6.2.2.1	General.....	91
13.6.2.2.2	Procedure	92
13.6.2.2.3	Exceptional procedures	92
13.6.2.3	Bearer connection modification procedure.....	92
13.6.2.3.1	General.....	92
13.6.2.3.2	Procedure	92
13.6.2.3.3	Exceptional procedures	93
13.6.3	Procedures specific for point-to-multipoint connections.....	95
13.6.3.1	Branch establishment procedure	95
13.6.3.1.1	General.....	95
13.6.3.1.2	Procedure	95
13.6.3.1.3	Exceptional procedures	95
13.6.3.2	Branch release procedure.....	96
13.6.3.2.1	General.....	96
13.6.3.2.2	Procedure	96
13.6.3.2.3	Exceptional procedures	97
13.6.4	B-BCC housekeeping procedures.....	97
13.6.4.1	B-BCC reset procedure.....	97
13.6.4.1.1	General.....	97
13.6.4.1.2	Procedure	97
13.6.4.1.3	Exceptional procedures	98
13.6.4.2	AN fault procedure	98
13.6.4.2.1	General.....	98
13.6.4.2.2	Procedure	98
13.6.4.2.3	Exceptional procedures	98
13.6.4.3	B-BCC pre-synchronization procedure.....	99
13.6.4.3.1	General.....	99
13.6.4.3.2	Procedure	99

13.6.4.3.3	Exceptional procedures	99
13.6.4.4	SAAL establishment procedure	99
13.6.4.4.1	General	99
13.6.4.4.2	Procedure	99
13.6.4.4.3	Exceptional procedure	100
13.6.4.5	B-BCC start-up procedure	100
13.6.4.5.1	General	100
13.6.4.5.2	Procedure	100
13.6.4.5.3	Exceptional procedures	100
13.6.4.6	B-BCC restart procedure	101
13.6.4.6.1	General	101
13.6.4.6.2	Procedure	101
13.6.4.6.3	Exceptional procedures	102
14	Message format and codes	102
14.1	Message and information element encoding principles	102
14.2	RTMC protocol messages and information elements	103
14.3	B-BCC protocol messages and information elements	103
14.3.1	Overview of B-BCC protocol messages	103
14.3.2	B-BCC messages for the support of basic B-BCC procedures	106
14.3.2.1	ALLOC message	106
14.3.2.2	ALLOC_ACC message	106
14.3.2.3	ALLOC_REJ message	107
14.3.2.4	ALLOC_COMP message	107
14.3.2.5	ALLOC_COMP_ACC message	107
14.3.2.6	ALLOC_COMP_REJ message	108
14.3.2.7	DEALLOC message	108
14.3.2.8	DEALLOC_ACC	108
14.3.3	B-BCC messages for the support of B-BCC housekeeping procedures	108
14.3.3.1	BCC_RESET message	108
14.3.3.2	BBCC_RESET_ACC message	109
14.3.3.3	BBCC_RESET_REJ message	109
14.3.3.4	BBCC_PRESYNC message	109
14.3.3.5	BBCC_PRESYNC_ACC message	109
14.3.3.6	BBCC_PRESYNC_REJ message	109
14.3.3.7	AN_FAULT message	110
14.3.3.8	AN_FAULT_ACC message	110
14.3.3.9	PROTOCOL_ERROR message	110
14.3.4	Additional B-BCC messages for the support of traffic parameter modification	110
14.3.4.1	MODIFY message	110
14.3.4.2	MODIFY_ACC message	111
14.3.4.3	MODIFY_REJ message	111
14.3.4.4	MODIFY_COMP message	111
14.3.4.5	MODIFY_COMP_ACC message	111
14.3.4.6	MODIFY_COMP_REJ message	112
14.3.4.7	MODIFY_ABORT message	112
14.3.4.8	MODIFY_ABORT_ACC message	112
14.3.4.9	MODIFY_ABORT_REJ message	112
14.3.5	Additional B-BCC messages for the support of point-to-multipoint connections	112
14.3.5.1	ADD_BRANCH message	112
14.3.5.2	ADD_BRANCH_ACC message	113
14.3.5.3	ADD_BRANCH_REJ message	113
14.3.5.4	UPDATE_BRANCH message	113
14.3.5.5	UPDATE_BRANCH_ACC message	113
14.3.5.6	UPDATE_BRANCH_REJ message	113
14.3.5.7	DROP_BRANCH message	114
14.3.5.8	DROP_BRANCH_ACC message	114
14.3.5.9	DROP_BRANCH_REJ message	114
14.3.6	B-BCC function specific information elements	114
14.3.6.1	Overview	114
14.3.6.2	Connection reference number	116

14.3.6.3	Connection reference number list	116
14.3.6.4	User port connection identifier	116
14.3.6.5	Service port connection identifier	117
14.3.6.6	Alternative user port VPCI	118
14.3.6.7	Alternative service port VPCI	119
14.3.6.8	Automatic congestion level	119
14.3.6.9	Reject cause	119
14.3.6.10	Branch identifier	120
14.3.6.11	Branch identifier list	120
14.3.7	B-BCC function information elements based on other Recommendations	120
14.3.7.1	ATM traffic descriptor	121
14.3.7.2	Broadband bearer capability	121
14.3.7.3	OAM traffic descriptor	121
14.3.7.4	QoS parameter	121
14.3.7.5	ABR set-up parameters	121
14.3.7.6	End-to-End transit delay	122
14.3.7.7	Cell delay variation tolerance (CDVT)	122
14.3.7.8	Alternative ATM traffic descriptor	122
14.3.7.9	Minimum acceptable ATM traffic descriptor	122
14.3.7.10	Protocol error cause	122
Annex A (normative):	SDL process diagrams	123
Annex B (normative):	Support of terminal equipment using the ATM Forum ATM UNI signalling version 4.0	124
B.1	Introduction	124
B.2	Principle differences	124
B.3	Protocol differences	124
B.4	Connection control procedures	125
B.5	Extensions to B-BCC message format and codes	125
B.5.1	ALLOC message	125
B.5.2	ALLOC_ACC message	126
B.5.3	ALLOC_COMP message	126
B.5.4	Additional B-BCC information element	126
B.5.4.1	Information element type coding	126
B.5.4.2	Extended QoS Parameters	126
B.5.4.3	ABR Additional Parameters	126
Annex C (informative):	Interworking between B-BCC and DSS2	127
C.1	Message interworking	127
C.1.1	Establishment of point-to-point connections	128
C.1.1.1	Connection establishment at the originating AN	128
C.1.1.2	Connection establishment at the terminating AN	129
C.1.1.3	Unsuccessful connection establishment	130
C.1.2	Transfer Phase	130
C.1.2.1	Successful connection modification at the originating AN	130
C.1.2.2	Successful connection modification at the terminating AN	131
C.1.2.3	Unsuccessful connection modification (Example 1: Rejected by network or user)	131
C.1.2.4	Unsuccessful connection modification (Example 2: Rejected by AN)	132
C.1.3	Release of point-to-point connections	132
C.1.4	Successful establishment of point-to-multipoint connections at the terminating AN	133
C.1.5	Release branches of point-to-multipoint connections	134
C.1.6	DSS2 Restart	135
C.2	Common use of information elements in DSS2 and VB5.2	135
C.2.1	Point-to-point connections	135
C.2.1.1	DSS2 SETUP message and B-BCC ALLOC message	135

C.2.1.2	DSS2 CONNECT message and B-BCC ALLOC_COMP message	136
C.2.1.3	DSS2 SETUP message and B-BCC ALLOC_ACC message	136
C.2.1.4	DSS2 RELEASE message and B-BCC DEALLOC message	136
C.2.1.5	DSS2 MODIFY REQUEST message and B-BCC MODIFY message	137
C.2.1.6	DSS2 MODIFY ACKNOWLEDGEMENT message and B-BCC Modify-COMP message	137
C.2.1.7	DSS2 MODIFY REQUEST message and B-BCC MODIFY_ACC message	137
C.2.1.8	Handling of B-BCC messages of type REJ	137
C.2.2	Point-to-multipoint connections	138
C.2.2.1	DSS2 SETUP message and B-BCC ADD_BRANCH_ACC message	138
C.2.2.2	DSS2 CONNECT message and B-BCC UPDATE_BRANCH message	138
C.2.2.3	Dropping a branch	138
Annex D (informative): Support of services with susceptibility to clipping		139
D.1	Case of direct access arrangements	139
D.2	Case of remote access arrangements with VB5.2 reference point	139
Annex E (informative): RTMC and B-BCC system relationship		142
Annex F (informative): Potential optimization of the B-BCC protocol to support switched broadcast services		143
F.1	General	143
F.1.1	New requirements for VB5.2 reference point	143
F.2	Additional B-BCC procedures	144
F.2.1	Link establishment procedure	144
F.2.1.1	General	144
F.2.1.2	Procedure	144
F.2.1.3	Exceptional procedures	145
F.2.2	Change branch procedure	145
F.2.2.1	General	145
F.2.2.2	Procedure	145
F.2.2.3	Exceptional procedures	145
F.3	Extended B-BCC message format and codes	146
F.3.1	Additional B-BCC messages	146
F.3.1.1	Message type coding	146
F.3.1.2	LINK_ALLOC message	146
F.3.1.3	LINK_ALLOC_ACC message	147
F.3.1.4	LINK_ALLOC_REJ message	147
F.3.1.5	CHANGE_BRANCH message	147
F.3.1.6	CHANGE_BRANCH_ACC message	147
F.3.1.7	CHANGE_BRANCH_REJ message	147
F.3.2	Additional B-BCC information element	148
F.3.2.1	Information element type coding	148
F.3.2.2	Old/new branch identifier	148
Bibliography		149
History		150

Intellectual Property Rights

IPRs essential or potentially essential to the present document may have been declared to ETSI. The information pertaining to these essential IPRs, if any, is publicly available for **ETSI members and non-members**, and can be found in SR 000 314: "*Intellectual Property Rights (IPRs); Essential, or potentially Essential, IPRs notified to ETSI in respect of ETSI standards*", which is available **free of charge** from the ETSI Secretariat. Latest updates are available on the ETSI Web server (<http://www.etsi.fr/ipr> or <http://www.etsi.org/ipr>).

Pursuant to the ETSI IPR Policy, no investigation, including IPR searches, has been carried out by ETSI. No guarantee can be given as to the existence of other IPRs not referenced in SR 000 314 (or the updates on the ETSI Web server) which are, or may be, or may become, essential to the present document.

Foreword

This European Standard (Telecommunications series) has been produced by ETSI Technical Committee Signalling Protocols and Switching (SPS) and is now submitted for the Public Enquiry phase of the ETSI standards Two-step Approval Procedure.

The present document is part 1 of a multi-part standard covering the interface at the VB5.2 reference point specification as identified below:

Part 1: "Interface specification";

Part 2: "Protocol Implementation Conformance Statement (PICS) proforma specification";

other parts may be produced later.

Proposed national transposition dates	
Date of latest announcement of this EN (doa):	3 months after ETSI publication
Date of latest publication of new National Standard or endorsement of this EN (dop/e):	6 months after doa
Date of withdrawal of any conflicting National Standard (dow):	6 months after doa

Introduction

General

The work on a new broadband VB reference point concept was initiated by ETSI Technical Committee Signalling Protocols and Switching (SPS) to consider, in co-operation with other groups involved, possible new structures and reference points for the connection of new broadband and combined narrowband/broadband access arrangements to Service Nodes (SN).

The work was taken over by a special experts group on VB5, working under the auspices of Working Group SPS3, within ETSI.

The VB5 reference point concept, based on ITU-T Recommendation G.902 [16], was split into two variants. The first based on an ATM cross connect with provisioned connectivity, called the VB5.1 reference point, is contained in EN 301 005-1 [1]. The other, which further enables on-demand connectivity within the AN, is called the VB5.2 reference point and is described in the present document.

Relationship between the VB5.1 and VB5.2 reference point concept

The VB5.2 reference point extends the capabilities at the VB5.1 reference point to include on-demand connectivity in the AN under the control of SN.

In addition to the major difference given above, the major correspondence between the VB5.1 and VB5.2 reference point can be described as:

- both VB5 interfaces support B-ISDN as well as narrowband and other non-B-ISDN customer access types;
- both VB5 interfaces support ATM multiplexing / cross-connecting in the AN at the virtual path and/or virtual channel level.

Associated standards and technical reports

The following set of standards relates to the VB5.2 reference point:

- DEN/TMN-00003;
- EN 301 005-1;
- EN 301 005-2;
- DEN/SPS-03047-2;
- EN 301 271.

1 Scope

The present document specifies the physical, procedural and protocol requirements for interfaces at the VB5.2 reference point between an Access Network (AN) and a Service Node (SN). The VB5.2 reference point provides flexible (provisioned) virtual path (VP) link allocation and flexible (provisioned) virtual channel (VC) link allocation (controlled by the Q3 interfaces) as well as on demand VC link allocation controlled by the SN via the broadband bearer connection control (B-BCC) protocol. That is, the VB5.2 reference point is a superset of the VB5.1 reference point, enabling on-demand VC link allocation in the AN and across the VB5 reference point via the additional B-BCC function.

The following B-ISDN customer access types with the general user network interface (UNI) characteristics defined in ITU-T Recommendation I.432.1 [22] are supported:

- a) B-ISDN accesses with a UNI at 155 520 kbit/s and 622 080 kbit/s according to ITU-T Recommendation I.432.2 [23], i.e.:
 - 1) SDH based according to ETS 300 300 [5];
 - 2) Cell based according to ETS 300 299 [4].
- b) B-ISDN access with a PDH based UNI at 1 544 kbit/s and 2 048 kbit/s according to ITU-T Recommendation I.432.3 [24].
- c) B-ISDN accesses with a UNI at 51 840 kbit/s or 25 600 kbit/s according to ITU-T Recommendations I.432.4 [25] and I.432.5 [26].

B-ISDN accesses with a UNI according to future ENs and/or ITU-T Recommendations may require additional functionality at the VB5.2 reference point.

In order to provide for a migration from narrowband to broadband access network and service node arrangements, narrowband access types as specified for:

- V5.1 interface according to ETS 300 324-1 [7] / ITU-T Recommendation G.964 [39]; and/or
- V5.2 interface according to ETS 300 347-1 [8] / ITU-T Recommendation G.965 [40],

are also supported according to the integration scenario given in ITU-T Recommendation G.902 [16], clause C.2.2, using a circuit emulation function for the transfer of circuit mode into ATM.

In addition to these B-ISDN and narrow-band customer access types, other non-B-ISDN access types are also supported.

Examples for such non-B-ISDN access types are given below:

- a) access types supporting asymmetric/multimedia services, e.g. Video on Demand (if not part of B-ISDN access types);
- b) access types supporting broadcast services (if not part of B-ISDN access types);
- c) access types supporting LAN interconnect functionality (if not part of B-ISDN access types);
- d) access types that can be supported via an ATM VP cross-connect.

The concept of Virtual User Ports (VUP), as described EN 301 005-1 [1], may be applied to enable any specific implementation.

In accordance with the principles of B-ISDN (as specified in ITU-T Recommendation I.121 [41]), remote access arrangements across interfaces at the VB5.2 reference point need to support switched, and (semi)-permanent point-to-point and point-to-multipoint connections. They provide on demand, reserved and permanent services of a mono- and/or multi-media type and of a connectionless or connection-oriented nature in a bidirectional or unidirectional configuration, as supported for direct access arrangements to service nodes.

Functions to support security management (refer to ITU-T Recommendation X.800 [46]) related to the customer access are beyond the scope of the present document. Such security management functions have no impact on the VB5.2 reference point.

The present document does not specify the implementation of the requirements within the AN and does not constrain any implementation alternative as long as the functionality at the interfaces at the VB5.2 reference point as specified in the present document is met. Furthermore, the present document does not require that an AN shall support all the customer access types listed above.

The present document is not intended to define any systems or equipment in, or connected to, an SN via interfaces at the VB5.2 reference point. Therefore only the characteristics of the interfaces at the VB5.2 reference point are described.

2 References

The following documents contain provisions which, through reference in this text, constitute provisions of the present document.

- References are either specific (identified by date of publication, edition number, version number, etc.) or non-specific.
- For a specific reference, subsequent revisions do not apply.
- For a non-specific reference, subsequent revisions do apply.
- A non-specific reference to an ETS shall also be taken to refer to later versions published as an EN with the same number.

- [1] EN 301 005-1: "V interfaces at the digital Service Node (SN); Interface at the VB5.1 reference point for the support of broadband or combined narrowband and broadband Access Network (AN); Part 1: Interface specification".
- [2] ETS 300 298-1 (1996): "Broadband Integrated Services Digital Network (B-ISDN); Asynchronous Transfer Mode (ATM); Part 1: B-ISDN ATM functional characteristics [ITU-T Recommendation I.150 (1995)]".
- [3] ETS 300 298-2 (1996): "Broadband Integrated Services Digital Network (B-ISDN); Asynchronous Transfer Mode (ATM); Part 2: B-ISDN ATM layer specification [ITU-T Recommendation I.361 (1995)]".
- [4] ETS 300 299 (1995): "Broadband Integrated Services Digital Network (B-ISDN); Cell based user network access; Physical layer interfaces for B-ISDN applications".

NOTE 1: This ETS is based on parts of ITU-T Recommendation I.432.1.

- [5] ETS 300 300 (1995): "Broadband Integrated Services Digital Network (B-ISDN); Synchronous Digital Hierarchy (SDH) based user network access; Physical layer interfaces for B-ISDN applications".

NOTE 2: This ETS is based on parts of ITU-T Recommendation I.432.1.

- [6] EN 300 301 (V1.1): "Broadband Integrated Services Digital Network (B-ISDN); Traffic control and congestion control in B-ISDN".

NOTE 3: The main body of this ETS is based on ITU-T Recommendation I.371.

- [7] ETS 300 324-1 (1994): "V interfaces at the digital Local Exchange (LE); V5.1 interface for the support of Access Network (AN); Part 1: V5.1 interface specification".
- [8] ETS 300 347-1 (1994): "V interfaces at the digital Local Exchange (LE); V5.2 interface for the support of Access Network (AN); Part 1: V5.2 interface specification".
- [9] ETS 300 404 (1997): "Broadband Integrated Services Digital Network (B-ISDN); B-ISDN Operation And Maintenance (OAM) principles and functions".
- [10] ETS 300 428 (1995): "Broadband Integrated Services Digital Network (B-ISDN); Asynchronous Transfer Mode (ATM) Adaptation Layer (AAL) specification - type 5".

- [11] ETS 300 436-1 (1995): "Broadband Integrated Services Digital Network (B-ISDN); Signalling ATM Adaptation Layer (SAAL); Service Specific Connection Oriented Protocol (SSCOP); Part 1: Protocol specification [ITU-T Recommendation Q.2110 (1995), modified]".
- [12] ETS 300 437-1 (1995): "Broadband Integrated Services Digital Network (B-ISDN); Signalling ATM Adaptation Layer (SAAL); Service Specific Co-ordination Function (SSCF) for support of signalling at the User-Network Interface (UNI); Part 1: Specification of SSCT at UNI. [ITU-T Recommendation Q.2130 (1995), modified]".
- [13] EN 300 443-1: "Broadband Integrated Services Digital Network (B-ISDN); Digital Subscriber Signalling System No. two (DSS2) protocol; B-ISDN user-network interface layer 3 specification for basic call/bearer control; Part 1: Protocol specification [ITU-T Recommendation Q.2931 (1995), modified]".
- [14] ETS 300 486-1 (1996): "Broadband Integrated Services Digital Network (B-ISDN); Meta-signalling protocol; Part 1: Protocol specification [ITU-T Recommendation Q.2120 (1995), modified]".
- [15] ITU-T Recommendation E.736 (1997): "Methods for cell level traffic control in B-ISDN".
- [16] ITU-T Recommendation G.902 (1995): "Framework Recommendation on functional access networks (AN); Architecture and functions, access types, management and service node aspects".
- [17] ITU-T Recommendation I.311 (1996): "B-ISDN general network aspects".
- [18] ITU-T Recommendation I.321 (1991): "B-ISDN protocol reference model and its application".
- [19] ITU-T Recommendation I.356 (1996): "B-ISDN ATM layer cell transfer performance".
- [20] ITU-T Recommendation I.363.5 (1996): "B-ISDN ATM Adaptation Layer (AAL), Type 5 AAL".
- [21] Draft revised ITU-T Recommendation I.414 (1997): "Overview of Recommendations on layer 1 for ISDN and B-ISDN customer accesses".
- [22] ITU-T Recommendation I.432.1 (1996): "B-ISDN user network interface; Physical layer specification; General characteristics".
- [23] ITU-T Recommendation I.432.2 (1996): "B-ISDN user network interface; Physical layer specification for 155 520 kbit/s and 622 080 kbit/s operation."
- [24] ITU-T Recommendation I.432.3 (1996): "B-ISDN user network interface; Physical layer specification for 1 544 kbit/s and 2 048 kbit/s operation".
- [25] ITU-T Recommendation I.432.4 (1996): "B-ISDN user network interface; Physical layer specification: 51 840 kbit/s operation".
- [26] ITU-T Recommendation I.432.5 (1997): "B-ISDN user network interface; Physical layer specification for the 25 600 kbit/s operation".
- [27] ITU-T Recommendation I.732 (1996): "Functional characteristics of ATM equipment".
- [28] ITU-T Recommendation Q.2931 (1995): "Broadband integrated services digital network (B-ISDN); Digital subscriber signalling system No. 2 (DSS 2); User-Network Interface (UNI); Layer 3 specification for basic call/connection control".
- [29] ITU-T Recommendation Q.2961-1 (1995): "Broadband Integrated Services Digital Network (B-ISDN); Digital Subscriber Signalling System No. 2 (DSS2); Additional traffic parameters: Additional signalling capabilities to support traffic parameters for the tagging option and the sustainable cell rate parameter set".

NOTE 4: Not yet published.

- [30] ITU-T Recommendation Q.2961.2 (1997): "Broadband Integrated Services Digital Network (B-ISDN); Digital Subscriber Signalling System No. 2 (DSS 2); Additional traffic parameters: Support of ATM transfer capability in the broadband bearer capability information element.

NOTE 5: Not yet published.

- [31] ITU-T Recommendation Q.2961.3 (1997): "Broadband Integrated Services Digital Network (B-ISDN); Digital Subscriber Signalling System No. 2 (DSS 2); Additional traffic parameters: Signalling capabilities to support traffic parameters for the available bit rate (ABR) ATM transfer capability".

NOTE 6: Not yet published.

- [32] ITU-T Recommendation Q.2961.4 (1997): "Broadband Integrated Services Digital Network (B-ISDN); Digital Subscriber Signalling System No. 2 (DSS 2); Additional traffic parameters: Signalling capabilities to support traffic parameters for the ATM block transfer (ABT) ATM transfer capability".

NOTE 7: Not yet published.

- [33] ITU-T Recommendation Q.2961.5: "DSS2 cell delay variation tolerance indication".

NOTE 8: Not yet published.

- [34] ITU-T Recommendation Q.2961.6: "Additional signalling procedures for the support of the SBR2 and SBR3 ATM transfer capabilities".

NOTE 9: Not yet published.

- [35] ITU-T Recommendation Q.2962 (1996): "Digital Subscriber Signalling System No. 2; Connection characteristics negotiation during call/connection establishment phase".

- [36] ITU-T Recommendation Q.2963.1 (1996): "Digital Subscriber Signalling System No. 2; Connection modification: Peak cell rate modification by the connection owner".

- [37] ITU-T Recommendation Q.2963.2 (1997): "Digital Subscriber Signalling System No. 2; Connection modification: Modification procedures for sustainable cell rate parameters".

- [38] ITU-T Recommendation Q.2971 (1995): "Broadband Integrated Services Digital Network (B-ISDN) - Digital Subscriber Signalling System No. 2 (DSS 2) - User-network interface layer 3 specification for point-to-multipoint call/connection control".

- [39] ITU-T Recommendation G.964 (1994): "V-Interfaces at the digital local exchange (LE); V5.1-interface (based on 2 048 kbit/s) for the support of access network (AN)".

- [40] ITU-T Recommendation G.965 (1995): "V-Interfaces at the digital local exchange (LE); V5.2 Interface (based on 2048 kbit/s) for the support of access network (AN)".

- [41] ITU-T Recommendation I.121 (1991): "Broadband aspects of ISDN".

- [42] ITU-T Recommendation I.150 (1995): "B-ISDN asynchronous transfer mode functional characteristics".

- [43] ITU-T Recommendation I.361 (1995): "B-ISDN ATM layer specification".

- [44] ITU-T Recommendation I.371 (1996): "Traffic control and congestion control in B-ISDN".

- [45] ITU-T Recommendation I.610 (1995): "B-ISDN operation and maintenance principles and functions".

- [46] ITU-T Recommendation X.800 (1991): "Security architecture for Open Systems Interconnection for CCITT applications".

- [47] Draft new ITU-T Recommendation Q.832.1: "VB5.1 management".

- [48] Draft new ITU-T Recommendation Q.832.2: "VB5.2 Management".

- [49] ITU-T Recommendation Q.2110 (1994): "B-ISDN ATM adaptation layer - Service specific connection oriented protocol (SSCOP)".
- [50] ITU-T Recommendation Q.2120 (1995): "B-ISDN meta-signalling protocol".
- [51] ITU-T Recommendation Q.2130 (1994): "B-ISDN signalling ATM adaptation layer - Service specific co-ordination function for support of signalling at the user-network interface (SSCF at UNI)".
- [52] ITU-T Recommendation E.412 (10/92): "Network management controls".
- [53] ITU-T Recommendation I.211: "B-ISDN service aspects".
- [54] ITU-T Recommendation I.372 (03/93): "Frame relaying bearer service network-to-network interface requirements".
- [55] ITU-T Recommendation I.731 (1996): "Types and general characteristics of ATM equipment".
- [56] ITU-T Recommendation Q.542: "Digital exchange design objectives; Operations and maintenance".
- [57] ITU-T Recommendation Q.823 (07/96): "Stage 2 and stage 3 functional specifications for traffic management".
- [58] ITU-T Recommendation Q.2650 (02/95): "Interworking between Signalling System No. 7 broadband ISDN user part (B-ISUP) and Digital Subscriber Signalling System No. 2 (DSS 2)".
- [59] ITU-T Recommendation M.3010: "Principles for a Telecommunications management network".
- [60] EN 301 005-2: "Interfaces at VB5.1 reference point for the support of broadband or combined narrowband/broadband access networks; Part 2: Protocol Implementation Conformance Statement (PICS)".
- [61] EN 301 271: "Telecommunications Management Network (TMN); Management interfaces associated with the VB5.1 reference point".

3 Definitions and abbreviations

3.1 Definitions

For the purposes of the present document, the following definitions apply:

B-BCC function: the set of connection control functions providing for the establishment, modification and release of the access network part of VCCs under control of the SN.

B-BCC protocol: the layer 3 protocol between SN and AN to support the B-BCC function.

In addition the present document uses terms defined in EN 301 005-1:

- Logical service port (LSP);
- Logical User Port (LUP);
- Physical Service Port (PSP);
- Physical User Port (PUP);
- RTMC function;
- RTMC protocol;
- Virtual User Port (VUP).

Although these definitions specially refer to the VB5.1 reference point, they apply equally to the VB5.2 reference point.

3.2 Abbreviations

For the purposes of the present document, the following abbreviations apply:

AAF	Access Adaptation Functions
AAL	ATM Adaptation Layer
AAL-SAP	ATM Adaptation Layer - Service Access Point
AALx	ATM Adaptation Layer type x
AN	Access Network
ATM	Asynchronous Transfer Mode
AXC	ATM Cross Connect
B-BCC	Broadband Bearer Connection Control
B-ET	Broadband Exchange Termination
B-ISDN	Broadband Integrated Services Digital Network
B-ISUP	Broadband ISDN Signalling User Part
B-LEX	Broadband Local Exchange
B-UNI	Broadband User Network Interface
CAC	Connection Admission Control
CBR	Constant Bit Rate
CE2	Circuit Emulation of 2 048 kbit/s signal
CLP	Cell Loss Priority
CLS	Connectionless Server
CPCS	Common Part Convergence Sub-layer
CPE	Customer Premises Equipment
CPN	Customer Premises NetworkPE
DSS2	Digital Subscriber Signalling system No. 2System No. 2 (see ITU-T Recommendation Q.2931 [28], EN 300 443-1 [13])
ET	Exchange Termination
FSM	Finite State Machine
ID	Identifier
ISDN	Integrated Services Digital Network
ISDN-BA	Integrated Services Digital Network - Basic Access
ISDN-PRA	Integrated Services Digital Network - Primary Rate Access
LAN	Local Area Network
LME	Layer Management Entity
LMI	Local Management Interface
LSP	Logical Service Port
LT	Line Termination
LUP	Logical User Port
MIB	Management Information Base
MSC	Message Sequence Chart
N-ISDN	Narrow-band - Integrated Services Digital Network
NNI	Network-Node Interface
NPC	Network Parameter Control
NT2	Network Termination type 2
OAM	Operations Administration and Maintenance
PDH	Plesiochronous Digital Hierarchy
PRM	Protocol Reference Model
PSP	Physical Service Port
PSTN	Public Switched Telephone Network
PM	Point-to-Multipoint
PP	Point-to-Point
PUP	Physical User Port
Q3	"Q" Management Interface reference point as in ITU-T Recommendation M.3010
QoS	Quality of Service
RTMC	Real Time Management Co-ordination (function)
SAAL	Signalling ATM Adaptation Layer
SAF	Specific Access Functions

SAP	Service Access Point
SAR	Segmentation and Reassembly
SDH	Synchronous Digital Hierarchy
SDU	Service Data Units
SN	Service Node
SNI	Service Node Interface
SOH	Section Overhead
SP	Service Port
SPF	Service Port Function
SSCF	Service Specific Co-ordination Function
SSCOP	Service Specific Connection Oriented Protocol
STM	Synchronous Transport Module
TC	Transmission Convergence (sublayer)
TE	Terminal Equipment
TMN	Telecommunication Management Network
TM	Transmission Media
TP	Transmission Path
TP-T	Transmission Path Termination
UNI	User Network Interface
UPC	Usage Parameter Control
UPF	User Port Function
VB	Broadband "V" Reference Point
VC	Virtual Channel
VCC	VC Connection
VCCT	VCC Termination
VCE	VC Entity
VCI	VC Identifier
VCL	VC Link
VCME	VC Multiplex Entity
VP	Virtual Path
VPC	VP Connection
VPCI	VPC Identifier
VPCT	VPC Termination
VPE	VP Entity
VPI	VP Identifier
VPL	VP Link
VPME	VP Multiplex Entity
VUP	Virtual User Port

4 Field of application

Within the general framework of the evolution to and application of the B-ISDN, the present document is intended to be applied to remote access arrangements with access networks as specified in ITU-T Recommendation I.414 [21] (case of B-ISDN customer access; remote access application with additional on-demand connection allocation in access network/VB5.2 reference point), providing customer access to various service node types as listed in subclause 4.4 of EN 301 005-1 [1].

Reference to access types, functions, interfaces, etc. in the present document does not imply that each of them has necessarily to be provided in every access network type or configuration. In general, the selection of features, functions and interfaces to be provided in an AN in a particular network application will be determined by the access network and service providers concerned.

The purpose of the VB5.2 reference point is to provide increased efficiency in the use of AN resources and SN resources associated with the SNI, over that possible with the VB5.1 reference point. Applications of the VB5.2 reference point are therefore the same as those described in clause 4 of EN 301 005-1 [1]. The principle difference is due to the addition of the B-BCC protocol. In all scenarios in the VB5.1 reference point specification where the RTMC protocol is shown there is an associated B-BCC protocol in the VB5.2 case. Use of this protocol allows dynamic resource allocation in the AN by the SN on a connection by connection basis in these scenarios, which is not possible using the VB5.1 reference point.

5 Introduction to the VB5.2 reference point concept

This clause defines the fundamental principles and requirements as well as the general functional architecture of remote access arrangements with a VB5.2 reference point.

The interface at the VB5.2 reference point is an ATM based instance of a service node interface (SNI). The VB5.2 reference point concept is based on ITU-T Recommendation G.902 [16].

Applying the terminology and definitions introduced in ITU-T Recommendation G.902 [16], the general characteristics of the VB5.2 reference point concept can be described as follows:

- The VB5.2 reference point belongs to the access integrating class of V reference points, i.e., the signal structure is a multiplex of several accesses of the same or of different access types.
- The VB5.2 reference point supports both service specific SNs (e.g., broadband local exchange, ATM based leased line SN) and modular SNs (e.g., combined narrowband and broadband local exchange).

5.1 General VB5.2 design principles

Within this subclause the fundamental principles for remote access arrangements with VB5.2 reference point are defined.

- a) An AN is used in order to multiplex/demultiplex the signalling and data streams from UNIs in a cost effective manner and then to present this information stream to the SN in a manner such that the SN can determine the source or sink UNI.
- b) The AN does not interpret (user) signalling.
- c) The responsibility for call control and associated connection control resides in the SN (i.e. the AN may have no knowledge of ongoing services and the call state during normal operation of the VB5.2 reference point).
- d) Selection of the service provider by the AN based on user signalling information shall not be possible, because this would require SN functionality in the AN.

However, for ATM based access types the AN shall support access to different SNs through a single UNI at the same time by using the corresponding VPs associated with these SNs via provisioning (see also subclause 5.3.1, shared UNI). In this case the selection of the service provider is a matter of the user terminal and does not concern the AN or the SNI.

- e) Time critical management functions which require real-time co-ordination between AN and SN shall be performed by communication across the VB5.2 reference point.
- f) According to ITU-T Recommendation I.414 [21], the VB5.2 reference point concept supports ATM multiplexing/cross connecting and on-demand VC link allocation in the AN under the control of the SN. On-demand VP link allocation in the AN is for further study.
- g) Charging information is transparently passed between the VB5.2 reference point and the user by the AN, when the user requires it as part of a service. This information is not passed over the VB5.2 reference point for use by the AN.
- h) Tones and announcements shall be generated in the SN and not in the AN.

i) If multicasting is provided in the AN, this shall be allowed to be performed in the SNI to UNI direction only. Otherwise multicasting is presumed to be a service provided by the SN.

k) Traffic control and congestion control functions (at the ATM layer) such as:

- use of VPs for network resource management;
- connection admission control (CAC);
- usage parameter control (UPC) / network parameter control (NPC) functions;
- priority control;
- traffic shaping;
- fast resource management;
- congestion control by selective cell discard and/or explicit forward congestion indication,

shall be performed in accordance with EN 300 301 [6] / ITU-T Recommendations I.371 [44], I.732 [27] and E.736 [15].

Some of the traffic control and congestion control functions (e.g., NPC, traffic shaping) are network options according to EN 300 301 [6] / ITU-T Recommendation I.371 [44].

l) The establishment of VC connections in the AN under the control of the SN shall be performed by communications via the VB5.2 reference point.

5.2 General reference model for the VB5.2 reference point

Subclause 5.2 of EN 301 005-1 [1] applies.

5.3 General characteristics of individual functional groups

5.3.1 User port function characteristics

Subclause 5.2 of EN 301 005-1 [1] applies.

5.3.2 ATM connection function characteristics

Within this subclause the characteristics of the ATM connection function in an AN with VB5.2 reference point are defined.

a) Association of user VPs to VB5.2 reference point.

A VP at the UNI shall be associated with one and only one VB5.2 reference point. The association is established on a static basis through provisioning of the corresponding logical user port and has to be co-ordinated with the relevant SN.

b) Provisioned connectivity.

The ATM connection function provides provisioned connectivity at VP and/or VC level (i.e. ATM cross connections at the VP and/or the VC level).

c) On-demand connectivity.

The ATM connection function provides on-demand connectivity at VC level under the control of the SN (i.e. via the B-BCC protocol).

5.3.3 Service port function characteristics

Subclause 5.3.3 of EN 301 005-1 [1] applies.

5.4 Functional modelling

This subclause specifies the modelling concepts applied to the user port function, service port function and the ATM connection function within an access arrangements with VB5.2 reference point. The modelling concepts are based on the general characteristics identified in subclauses 5.3.1 and 5.3.2.

5.4.1 Modelling of user port function

The contents of this subclause are identical to subclause 5.4.1 of EN 301 005-1 [1].

5.4.2 Modelling of service port function

Subclause 5.4.2 of EN 301 005-1 [1] applies.

5.4.3 Modelling of ATM connection function

The ATM connection function within an AN with a VB5.2 reference point provides:

- provisioned connectivity at VP level;
- provisioned connectivity at VC level;
- on-demand connectivity at VC level;
- within the provisioned association of a logical user port with a logical service port. In case of a VC cross connection function all VC links within a VP at a logical user port are cross connected to VC links at the same logical service port.

ATM cross connections at VP level are performed by provisioning. ATM cross connections at VC level are performed by provisioning or on-demand.

The functional model for the ATM connection function within the AN is illustrated in figure 1 for a configuration example where two logical service ports (i.e., VB5.2 reference points) exist in the AN.

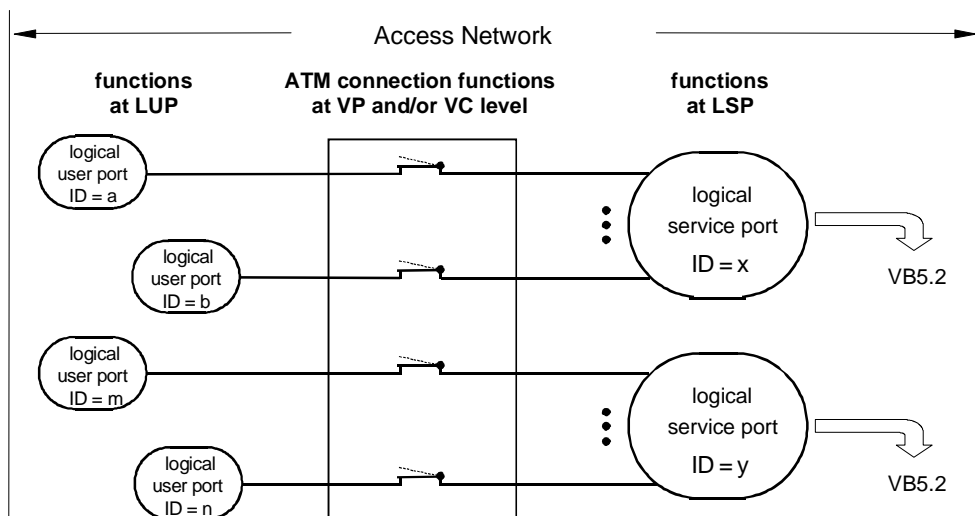

Figure 1: Functional model for ATM connection function within AN

5.5 AN view and SN view of physical and logical ports

Subclause 5.5 of EN 301 005-1 [1] applies.

6 Procedural interface requirements

6.1 Introduction

The functional description of the VB5.2 reference point at a (physical) interface is illustrated in figure 2.

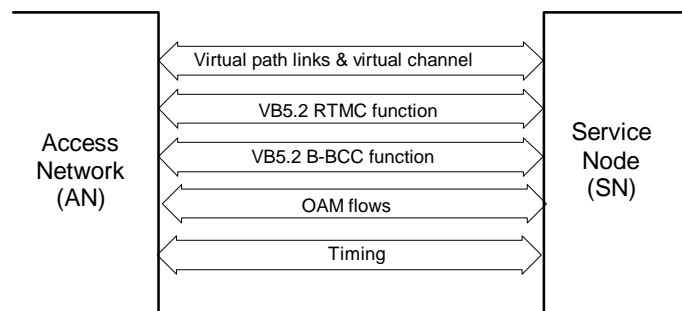

Figure 2: Functions at an interface at the VB5.2 reference point

The indicated functions are shortly described below:

a) Virtual path links and virtual channel links:

The VB5.2 reference point supports the ATM layer for user plane (i.e. user data), control plane (i.e. user to network signalling and B-BCC signalling) and management plane (e.g. meta-signalling, if any, and RTMC protocol) information. This information will be carried on virtual channel links. The virtual channel links will be carried in virtual path links.

b) Real Time Management Co-ordination (RTMC) function:

This function provides management plane co-ordination (including, synchronization and consistency) between access network and service node via a dedicated protocol (referred to as RTMC protocol) across the VB5.2 reference point. The protocol is used for exchanging time critical management plane information between AN and SN.

Functions which are not time-critical (i.e. interface and user port provisioning) that require a co-ordinated view at both sides of the VB5.2 reference point are performed via Q3 interfaces (i.e. via system management functions of AN and SN) (see also ITU-T Recommendation G.902 [16]).

c) Broadband Bearer Connection Control function (B-BCC):

This function provides the mechanism by which the SN requests the AN to establish, modify and release VC links on demand in the AN with the negotiated connection attributes such as traffic descriptors and QoS parameters.

d) OAM flows:

This function provides layer related exchange of OAM information. These flows exist at the ATM layer and may exist at the physical layer.

e) Timing:

This function provides the necessary information for bit (signal element) transmission, octet and cell boundaries (i.e. cell delineation).

For the definition of the functional and procedural interface requirements, the B-ISDN Protocol Reference Model (PRM) defined in ITU-T Recommendation I.321 [18] is applied in the following subclauses.

6.2 Physical layer requirements

Subclause 6.2 of EN 301 005-1 [1] applies.

6.3 ATM layer requirements

The user information together with the information for connection related functions (i.e. user-to-network signalling) and OAM information (at the ATM layer or at a higher layer) are carried in ATM cells belonging to a virtual channel link and virtual path link.

6.3.1 Cell header format and encoding and pre-assigned cell headers for use by the ATM layer

The cell header format and encoding and the pre-assigned headers for use by the ATM layer used at the VB5.2 reference point shall comply with the Network-to-Network Interface (NNI) specifications of ITU-T Recommendation I.361 [43] / ETS 300 298-2 [3].

6.3.2 Cell Loss Priority (CLP)

Depending on the network conditions, cells where the CLP is set (i.e. value of the CLP bit is 1) are subject to be discarded prior to cells where the CLP is not set (i.e. value of the CLP bit is 0). See ITU-T Recommendation I.371 / EN 300 301 [6] for further details about the use of the CLP bit.

6.3.3 VPC carrying RTMC and B-BCC protocol VCCs

The VPC which contains the RTMC protocol VCC and the B-BCC VCC shall not carry any user data or user signalling traffic.

6.3.4 OAM

The operation and maintenance principles based on F4 and F5 OAM flows as defined in ETS 300 404 [9] / ITU-T Recommendation I.610 [45] are applicable.

6.4 Higher layer interface requirements

6.4.1 User plane

For ATM based accesses the layers above the ATM layer are transparent within the AN.

For the support of non-B-ISDN access types which do not support the ATM layer, ATM Adaptation Layer (AAL) functions have to be provided within the AN.

No other higher layer interface requirements are identified for the transfer of user plane information across the VB5.2 reference point.

6.4.2 Control plane

The Connection Admission Control / Resource Management functions in the SN communicate via the B-BCC with their peers in the AN. The AAL for the B-BCC protocol is specified in subclause 6.4.6.

User to network signalling applied at the CPE is handled transparently within the AN. The peer entity is the SN.

In order to support some specific non-B-ISDN accesses (see clause 8), the AN may apply B-UNI signalling. The signalling protocol conversion function which may be required within the AN to support such access types is beyond the scope of the present document.

Signalling VCCs across the VB5.2 reference point shall be handled as (semi-)permanent connections.

An access network arrangement with VB5.2 reference point can also support terminals using non-B-ISDN user-to-network signalling systems applied at the CPE and the SN and transported transparently over the AN. This feature is a consequence of the basic principle that user-to-network signalling is not terminated by the AN.

6.4.3 Management plane

For the management of an AN/SN configuration using a VB5.2 reference point, co-ordination between management plane functions of the AN and SN is required. Two types of co-ordination exist:

- non-real-time management co-ordination;
- real time management co-ordination.

Non-real-time management co-ordination is realized via the TMN and hence the respective Q3 interfaces of the involved network elements: i.e. Q3(AN) and Q3(SN).

Real Time Management Co-ordination (RTMC) shall be supported via a dedicated protocol (i.e. RTMC protocol). The RTMC protocol and associated procedures belong to the plane management functions of AN and SN. These functions are specified in separate clauses in the present document. The AAL for the RTMC protocol is specified in subclause 6.4.5.

6.4.4 Establishment of VP and VC links/connections

6.4.4.1 Establishment of VP links and connections

Virtual Path Links (VPLs) at the VB5.2 reference point are always established via management plane functions of the AN, SN and (if applicable) the transport networks.

6.4.4.2 Establishment of VC links and VC connections

VCLs at the VB5.2 reference point are carried by VPLs/VPCs, which are established at the VB5.2 reference point.

The same is valid for the VCLs at the UNI or VUP. With relation to the VCLs and VCCs, the following types can be distinguished:

- a) VCLs of VCCs provisioned in the AN.

VCLs which are part of VCCs that are cross-connected in the AN shall be established via management plane functions of the AN and SN.

- b) VCLs of VCCs established on demand in the AN.

VCLs which are part of VCCs that are established on demand in the AN shall be established via the B-BCC functions of the AN and SN.

- c) VCLs carried in VPCs that are cross-connected in the AN.

VCLs carried in VPCs which are cross-connected in the AN are established either via management plane functions or via control plane functions. These management plane or control plane functions are located in the SN; and

- are in the B-ISDN customer premises equipment (i.e. in case of B-ISDN access types); or
- are in access adaptation functions which are considered to be part of the AN (i.e. in case of non-B-ISDN access types). The signalling protocol conversion function which may be required within the AN to support such access types is beyond the scope of the present document.

d) The VCL of the VCC carrying the RTMC protocol.

The VCL of the VCC which is carrying the RTMC protocol is established via management plane functions of the AN and SN.

e) The VCL of the VCC carrying the B-BCC protocol.

The VCL of the VCC which is carrying the B-BCC protocol is established via management plane functions of the AN and SN.

6.4.5 ATM adaptation layer for the RTMC protocol

Subclause 6.4.5 of EN 301 005-1 [1] applies.

6.4.6 ATM adaptation layer for the B-BCC protocol

6.4.6.1 General AAL requirements

The B-BCC protocol shall use the Signalling ATM Adaptation Layer (SAAL). This AAL consists of the parts specified in ITU-T Recommendations I.363.5 [20], Q.2110 / ETS 300 436-1 [11] and ITU-T Recommendation Q.2130 / ETS 300 437-1 [12].

6.4.6.2 AAL5 requirements

The requirements for the AAL5 are defined in ITU-T Recommendation I.363.5 [20] and ETS 300 428 [10].

The following selections apply:

- only the message mode service is needed for the B-BCC protocol;
- corrupted messages will not be delivered to the B-BCC protocol entity.

6.4.6.3 SSCOP requirements

The requirements for the SSCOP are defined in ITU-T Recommendation Q.2110 [49] / ETS 300 436-1 [11].

The following selections apply:

- local data retrieval: this function is not needed by the B-BCC protocol;
- re-synchronization is an inherent part of the SSCOP and has to be supported;
- status reporting: no management data needs to be exchanged between the two peer entities for the B-BCC protocol;
- the SSCOP protocol entities will not exchange extra data between them (SSCOP-user to user) for the B-BCC protocol;
- at release of the connection the message buffers should be cleared;
- the value for MaxSTAT as defined in subclause 7.7 of ITU-T Recommendation Q.2110 [49] / ETS 300 436-1 [11] shall be one of the default values;
- the other values are given in subclause 6.4.6.4 of the present document;
- the default window size shall be 5 as defined in appendix IV of ITU-T Recommendation Q.2110 [49] / ETS 300 436-1 [11].

6.4.6.4 SSCF requirements

The requirements for the SSCF are defined in ITU-T Recommendation Q.2130 [51] / ETS 300 437-1 [12].

The following selections apply:

- the B-BCC protocol needs only the assured transfer of data but not the "Unacknowledged Transfer of Data";
- the B-BCC protocol does not need the AA-Parameter SSCOP-user-to-user;
- the parameters of table 4 of ITU-T Recommendation Q.2130 [51] / ETS 300 437-1 [12] shall apply.

6.5 Meta-signalling

Broadband meta-signalling applied at the CPE is handled transparently within the AN. The peer entity is the SN.

In order to support some specific non-B-ISDN accesses (see clause 8), the AN may apply broadband meta-signalling. The protocol conversion function which may be required within the AN to support such access types is beyond the scope of the present document.

At the VB5.2 reference point, B-ISDN user meta-signalling (refer to ITU-T Recommendation Q.2120 [50] / ETS 300 486-1 [14]) shall be applied for the allocation of signalling virtual channel links at the VB5.2 reference point, which are handled transparently between the user ports or virtual user ports (see clause 8) and the SN. The meta-signalling VCC is part of and carried over the VB5.2 reference point.

It is noted that an access network conform to VB5.2 can be used with other broadband meta-signalling systems applied at the CPE and the SN and transported transparently over the AN. This feature is a consequence of the basic principle that meta-signalling is not terminated by the AN. This is however outside the scope of the present document.

VCLs carrying meta-signalling may be provisioned using management interfaces, or set up under the control of the B-BCC protocol.

6.6 Interface Management Application

Subclause 6.6 of EN 301 005-1 [1] applies.

6.7 Usage information transfer

Requirements for the transfer of usage information (e.g. for accounting purposes) across the VB5.2 reference point are for further study.

7 Broadband access network connection types

This clause specifies the basic broadband connection types which are required across access networks with VB5.2 reference point. This specification does not imply that every access network with VB5.2 reference point shall have the capability to support all these connection types.

7.1 Introduction to connections/connection elements

Subclause 7.1 of EN 301 005-1 [1] applies.

7.2 Multipoint requirements

The access network (i.e., the ATM cross connection function) shall be capable of supporting a point-to-multipoint (multicast) function on a given number of virtual connections.

The point-to-multipoint connections are unidirectional in the direction SN to UNI.

Requirements for bi-directional point-to-multipoint connections are for further study within ITU-T and their impact on the VB5 reference point will have to be investigated. (For example, for the case of bi-directional point-to-multipoint connections the return peak cell rate on the root link may be required not to exceed the sum of the return peak cell rates on all the leaf ATM links to maintain suitable cell loss performance for the overall connection).

A multipoint-to-multipoint connection is for further study.

7.3 Broadband access network connection element identifiers

Connection element identifiers have already been introduced in direct access arrangements for use by the user signalling procedures. For remote access arrangements with VB5.2 reference point, connection element identifiers are additionally required for both the RTMC function and the B-BCC function.

7.3.1 Connection element identifiers in user-to-network signalling messages

Subclause 7.3.1 of EN 301 005-1 [1] applies.

7.3.2 Connection element identifiers in RTMC messages

Subclause 7.3.2 of EN 301 005-1 [1] applies.

7.3.3 Connection element identifiers in B-BCC messages

For the B-BCC function a mechanism for the unique identification of VPCs and VC links at the UNI and at the VB5.2 reference point is required.

The concept of VPCIs and VCIs shall be applied within the B-BCC protocol in order to identify the corresponding user information flow, i.e., the VPC and the VC link within the VPC. Both the AN and the SN must understand the relationship between the VPCI and VCI values used in the B-BCC protocol and the actual VPI/VCI combination used in the cell header for the user information flow.

- a) Identification of a VPC and a VC link at the UNI terminated at the user port function of the AN (see also figure 6).

The VPCI allocated to a given VPC shall be unique within the corresponding logical user port. The logical user port is identified by an LUP identifier which is unique within each VB5.2 reference point.

Where user-to-network signalling is applied, the B-BCC function shall use the same VPCI values as they are applied in the user-to-network signalling protocol.

According to general ATM characteristics defined in ETS 300 298-1 [2] / ITU-T Recommendation I.150 [42], the VCI allocated to a given VC link shall be unique within the corresponding VPC.

- b) Identification of a VPC and a VC link at the VB5.2 reference point terminated at the service port function of the AN (see also figure 6).

For the identification of a VPC at the VB5.2 reference point terminated at the service port side of the AN the concept of VPCIs is applied as well. The VPCI allocated to a given VPC of this type shall be unique within the corresponding logical service port. The logical service port is identified by an LSP identifier.

According to general ATM characteristics defined in ETS 300 298-1 [2] / ITU-T Recommendation I.150 [42], the VCI allocated to a given VC link shall be unique within the corresponding VPC.

7.4 Overview of broadband access network connection types

An overview of the broadband AN connection types in an access arrangement with VB5.2 reference point is given in table 1. A detailed description is provided in subclauses 7.5 and 7.6.

Table 1: Overview of broadband AN connection types

Connection type	Level	Config.	Access types supported	Description	Supported by
Type A	VP or VC	PP or PM	B-ISDN	Connections (under control of the Q3(AN) and Q3(SN) interfaces) between the UNI and the SN.	VB5.1 and VB5.2
Type B	VP or VC	PP	—	Network internal connections (under control of the Q3(AN) and Q3(SN) interfaces) between AN and SN for the support of e.g. the RTMC function and B-BCC function.	VB5.1 and VB5.2
Type C	VC	PP or PM	B-ISDN	Connections (under control of the SN via the B-BCC) between the UNI and the SN.	VB5.2 only
Type D	VP or VC	PP or PM	Non-B-ISDN	Connections (under control of the Q3(AN) and Q3(SN) interfaces) between a virtual user port and the SN.	VB5.1 and VB5.2
Type E	VC	PP or PM	Non-B-ISDN	Connections (under control of the SN via the B-BCC) between a virtual user port and the SN.	VB5.2 only
NOTE:	In the SN, a broadband AN connections of type A, C, D or E may be either terminated or cross connected. This depends on the service provided by the SN.				

7.5 B-ISDN type broadband access network connections

7.5.1 Type A broadband access network connections

Subclause 7.5.1 of EN 301 005-1 [1] applies.

7.5.2 Type B broadband access network connections

Subclause 7.5.2 of EN 301 005-1 [1] applies.

7.5.3 Type C broadband access network connections

Type C broadband access network connections are established, released and maintained under control of the SN via the B-BCC protocol and support the application of connections where the access network provides connection point functions as defined in ITU-T Recommendation I.311 [17].

7.5.3.1 Type C-VC broadband access network connections

Type C-VC broadband access network connections support the application of point-to-point (see figure 3) and unidirectional point-to-multipoint (see figure 4) VC links where the access network provides VC connection point functions (e.g., translation of VCI values and re-assignment of VPI values).

VCCs with pre-assigned VCI values at the UNI as defined in ITU-T Recommendation I.361 [43] / ETS 300 298-2 [3] shall utilize VCI values in the range of 32 up to 65 535 at the VB5.2 reference point.

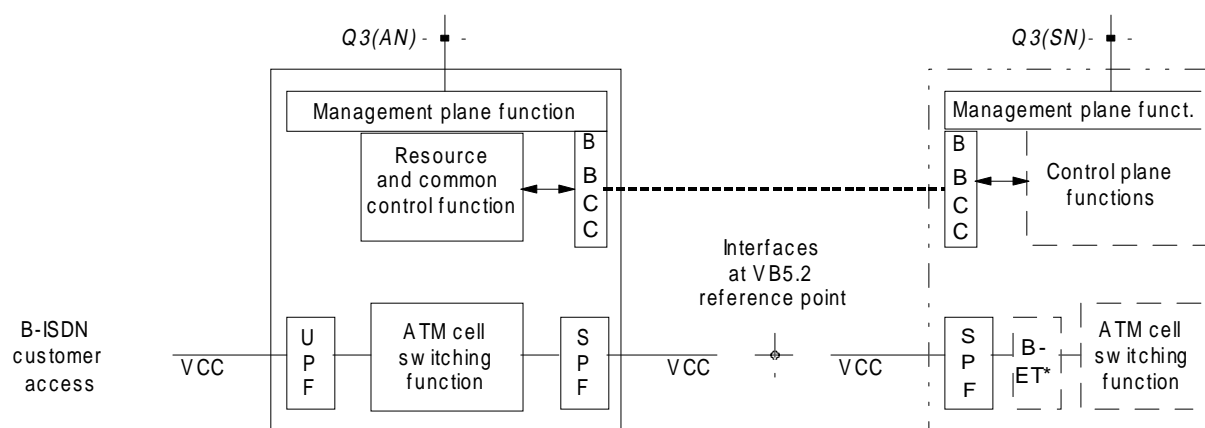

Figure 3: Type C-VC point-to-point broadband access network connection

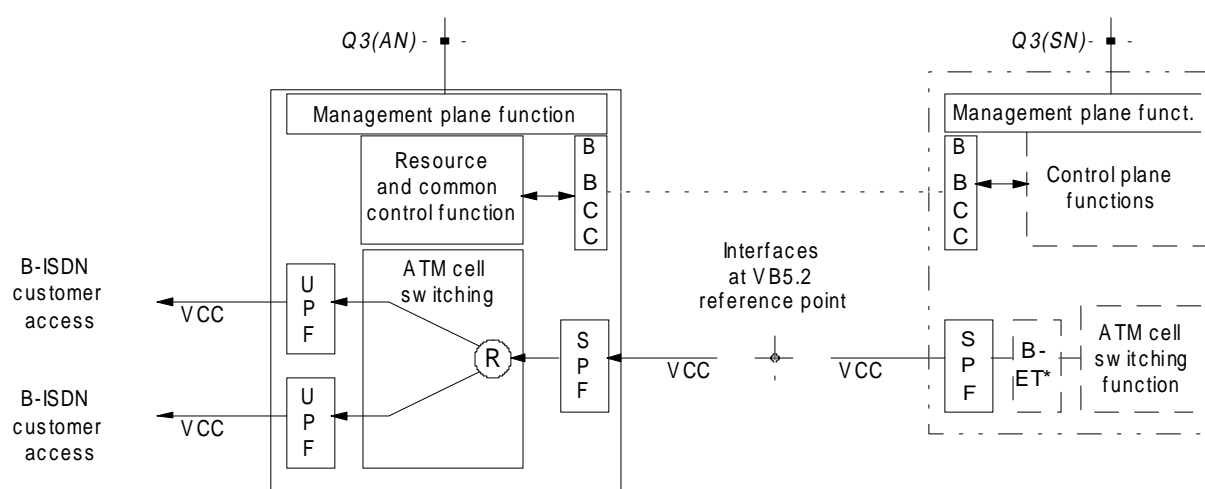

Figure 4: Type C-VC point-to-multipoint broadband access network connections

In addition to the VC connection point functions the AN also provides the cell replication function.

7.5.3.2 Application of type C-VC PP broadband AN connection

Type C connections can be used to support different types of user services:

- Switched services, where the B-BCC function in the SN is triggered by the SN call/connection control function.
- (Semi-) permanent leased line services, where the B-BCC function in the SN is triggered by operator actions at the SN management interface. A configuration related to the allocation of on-demand VCCs to support user calls is illustrated in figure 5. This scenario consists of an AN providing on-demand connectivity under control of the B-BCC protocol and an SN providing broadband local exchange functions.

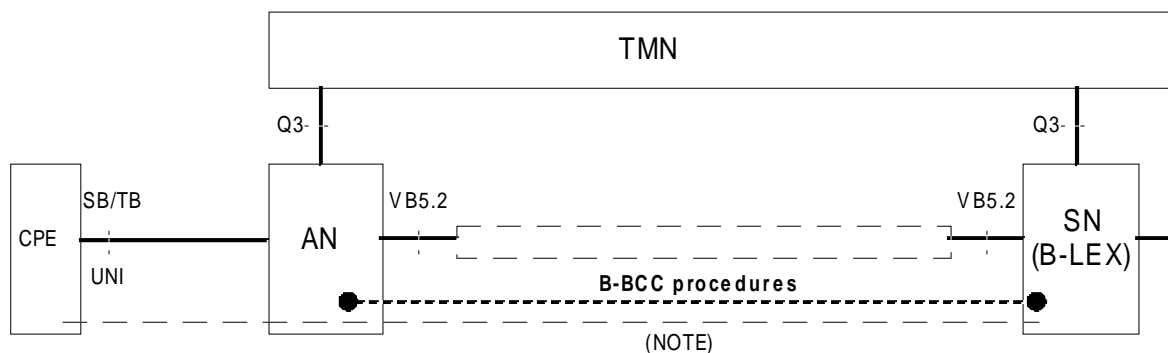

NOTE: Control plane communication (user-network signalling).

Figure 5: Remote access via VB5.2 reference point to a "B-LEX" SN

It is assumed that both the establishment and the release of on-demand VCCs within such an access arrangement is performed in two steps:

- 1) User-to-network signalling procedures (e.g., DSS2 procedures according EN 300 443-1 [13] for the basic call/connection). The user-to-network signalling information will be transferred transparently through the AN, hence, the AN will not be involved in this procedure.

These procedures includes both call control and connection control aspects.

- 2) SN-to-AN connection establishment procedures according to the broadband bearer connection control (B-BCC) function.

These procedures will include connection control aspects only.

An example for the handling of resource identifiers related to the configuration given in figure 5 is illustrated in figure 6.

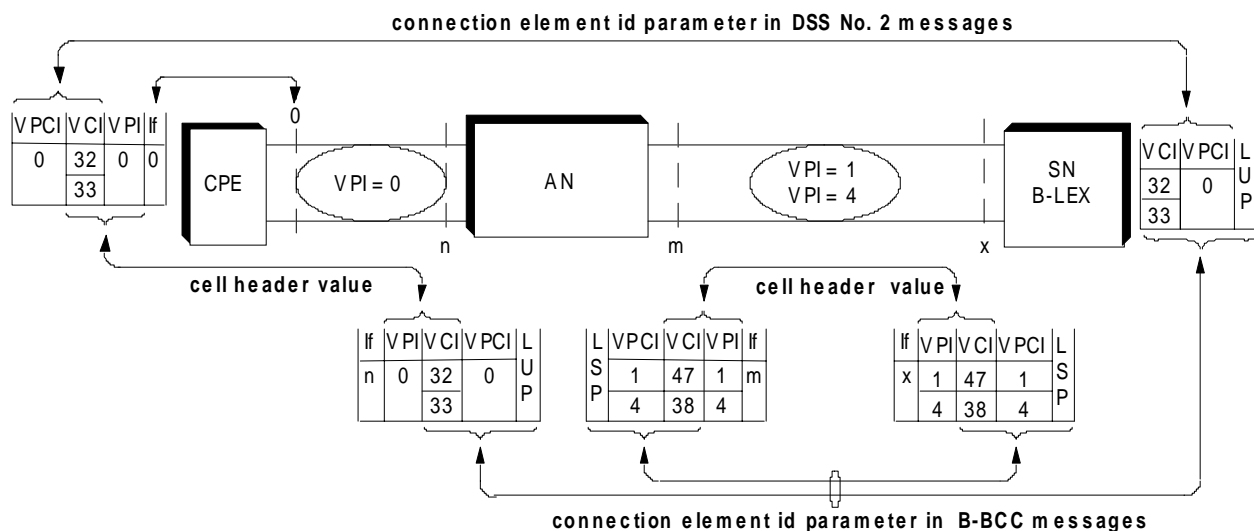

NOTE 1: The interface identifier If refers to a single transmission convergence function.

NOTE 2: In case of an additional VP cross connect function between AN and SN, the one-to-one mapping between VPI and VPCI values will no longer apply.

NOTE 3: According to EN 301 005-1 [1], the parameter combinations LUP/VPCI and LUP/VPCI are also used within RTMC messages.

Figure 6: Use of resource identifiers in a VB5.2 environment

At the top of the diagram in figure 6 the signalling relationship between the customer and the SN is illustrated.

In the middle part of the diagram examples for the use of cell header values (i.e., VPI and VCI values) are given.

At the bottom of the diagram the VB5.2 specific relationship between AN and SN based on the B-BCC function is illustrated. In this simple example without a transport network between AN and SN, the same values have been used for the VPI and the VPCI.

7.6 Non-B-ISDN type broadband access network connections

7.6.1 Type D broadband access network connections

The contents of this subclause are identical to subclause 7.6 of EN 301 005-1 [1].

7.6.2 Type E broadband access network connections

Type E broadband access network connections are established, released and maintained under control of the SN via the B-BCC protocol and support the application of connections between a virtual user port and the VB5.2 reference point.

7.6.2A Type E-VC broadband access network connection

Type E-VC broadband access network connection supports the application of point-to-point and point-to-multipoint VC links where the access network provides VC connection point functions. In the case of non ATM based accesses the AN additionally provides VC connection end-point functions (as part of the access adaptation functions).

8 Handling of non-B-ISDN access types

8.1 General considerations

The broadband accesses defined under the general title of B-ISDN should become the predominant accesses to support telecommunications services at some point in the future. At present, the narrowband accesses such as the access to the PSTN, ISDN-BA and ISDN-PRA are the predominant accesses for service offerings by telecommunications operators. There will need to be an interim changeover period when broadband and narrowband accesses co-exist over the same access network infrastructure. In addition, other non-B-ISDN accesses will be supported by the access network.

The non-B-ISDN access types are split into two clearly defined subgroups: those supporting ATM as the only possible transport mode and those which do not support ATM at all. The latter subgroup includes the narrowband accesses. An access supporting a mix of ATM and non-ATM transport modes is not excluded (i.e. ATM and STM provided on a single physical access). The principles for ATM based and non-ATM based accesses shall be combined in such cases.

The VB5.2 reference point and associated functions are specified in such a way that the AN is service independent. Therefore, the inclusion of service specific access types are not mandatory. Instead, they are considered as "plug-in" entities which rely on the service independent capabilities of the VB5.2 reference point and the associated AN.

Further, it should be noted that non-B-ISDN accesses can also be supported by siting interworking/terminal adaptation functions on the customer side of the B-UNI.

The descriptions given in the next subclauses do not restrict any implementation strategy with respect to non-B-ISDN accesses.

8.2 ATM based accesses

8.2.1 General approach

A number of interfaces, supporting the ATM layer, are currently being defined in order to provide cost-effective solutions to interconnect customer premises equipment to a broadband public network. It is likely that these interfaces will be supported in first implementations of broadband access networks, and should therefore be considered within the scope of the present document.

It should be noted that it is possible that some of these accesses become part of B-ISDN as soon as the relevant standards are defined (e.g. within the UNI specification of ITU-T Recommendation series I.432 [22], [23], [24], [25], [26]). This is beyond the scope of the present document.

As a general principle, the support of these types of interfaces shall not impact the basic principles of the VB5.2 reference point specification. All specifics related to these interfaces shall be hidden to the VB5.2 reference point by additional functions within the AN.

The additional functions of the AN, to support ATM based non-B-ISDN accesses, are referred to as "Access Adaptation Functions (AAFs)" (see figure 7). Such functions may be necessary in the user plane and/or control plane and/or management plane. One or more Virtual User Ports (VUPs) may be introduced at the boundary of the AAFs and the remaining ATM based access network functions. The introduction of VUPs is only required if otherwise the characteristic information and protocols over the VB5.2 reference point would be impacted.

AAFs may be introduced in any combination of user, control or management planes.

It should be noted that the introduction of VUPs for the sake of adaptations in the management or control plane does not exclude the existence of physical user ports in the user plane.

A description along the line of the B-ISDN protocol reference model is given in following subclauses.

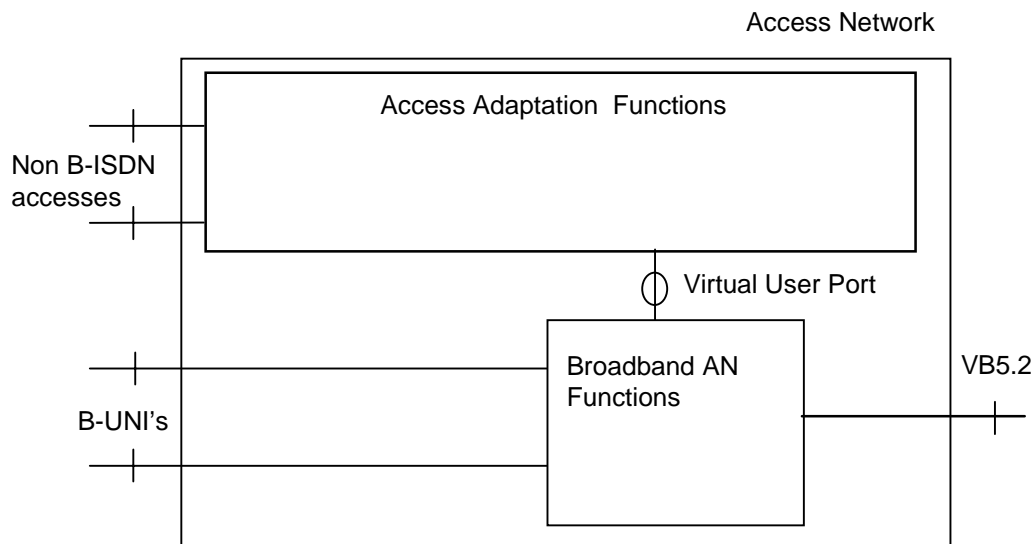

Figure 7: Generic model for support of non-B-ISDN accesses

8.2.2 User plane

If ATM, as described in ITU-T Recommendations I.361 [43] / ETS 300 298-2 [3] and I.610 [45], is used on the non-B-ISDN ATM based access, it shall have no additional impact on the VB5.2 reference point. The physical layer of the UNI is only known in the AN (i.e. not at the SN). In addition, no physical layer related information shall be conveyed across the VB5.2 reference point.

Deviation from the above shall be accommodated by the introduction the appropriate ATM Adaptation Functions.

8.2.3 Control plane

The VC connections supporting the user plane traffic from non-B-ISDN, ATM based accesses shall be on-demand or semi-permanent.

On-demand VC connections shall be established using the B-BCC protocol by the SN.

NOTE: VP connections may be established by provisioning between the SN and the user via the AAF of the VUP to support switched VC connections. In this case since the VC connections within the VP connection are transparent to the AN, there are no control plane requirements in the AN and the B-BCC is not used.

On demand VC connections are either allocated via B-ISDN user-network-signalling or by other means at the non-B-ISDN UNI. In the latter case, AAFs in the VUP may be used to generate DSS2 signalling towards the SN.

The VUP concept can be used to support terminals at the CPE which do not have B-ISDN user-to-network signalling capabilities. Instead, such terminals could support dedicated signalling protocols which trigger the B-ISDN user-to-network signalling facility within the AN. This capability supports for example proxy signalling agents within the AN. However, since the AN is transparent to user signalling, this is not mandatory.

8.2.4 Management plane

AAFs may be required as part of management plane procedures (i.e. conversion to B-ISDN meta-signalling).

The introduction of the virtual user port does not preclude that ATM based, non-B-ISDN access specifics are managed via the Q3(AN) interface, e.g. the MIB of the AN should be extended if it is required to configure/monitor the physical layer of the UNI.

The establishment of a semi-permanent VC connections, with one endpoint in the AAFs, shall be possible via:

- co-ordinated provision using Q3(AN) and Q3(SN);
- Q3(SN) only in conjunction with the B-BCC to control an associated AN part of the connection.

Cross-connections within the AAF are outside the scope of the present document.

Towards the CPE a Local Management Interface (LMI) is optional as part of the AN (i.e. user port function). This is beyond the scope of the present document.

8.3 Non-ATM based accesses

8.3.1 General approach

Non-ATM based accesses need to be handled case by case to identify the specific functions within the AN to support these access types.

As a general principle, the support of these types of interfaces shall not impact the basic principles of the VB5.2 reference point specification. All specifics related to these interfaces shall be hidden to the VB5.2 reference point by additional functions within the AN.

The additional functions of the AN, to support non-ATM, non-B-ISDN accesses, are referred to as "Access Adaptation Functions" (see figure 8). Such functions will be required in the user plane. In addition, adaptation functions may be required for control plane and/or management plane.

A description along the lines of the B-ISDN protocol reference model is given in following subclauses.

8.3.1.1 User plane

The required functionality and associated protocol stack is depicted in figure 8.

Compared to the case of a B-UNI access, a non-ATM based access will require AAL functionality to be performed in the access network. This AAL shall be a standardized type. Other functionality will depend on the type of the access and is referred "Specific Access Functions" (SAF) in figure 8.

Figure 8 gives the general approach for treating non-ATM based accesses. The SAF and associated AAL functionality, apart from the narrowband access (see subclause 8.3.2), is out of the scope of the present document and should be covered by other standards.

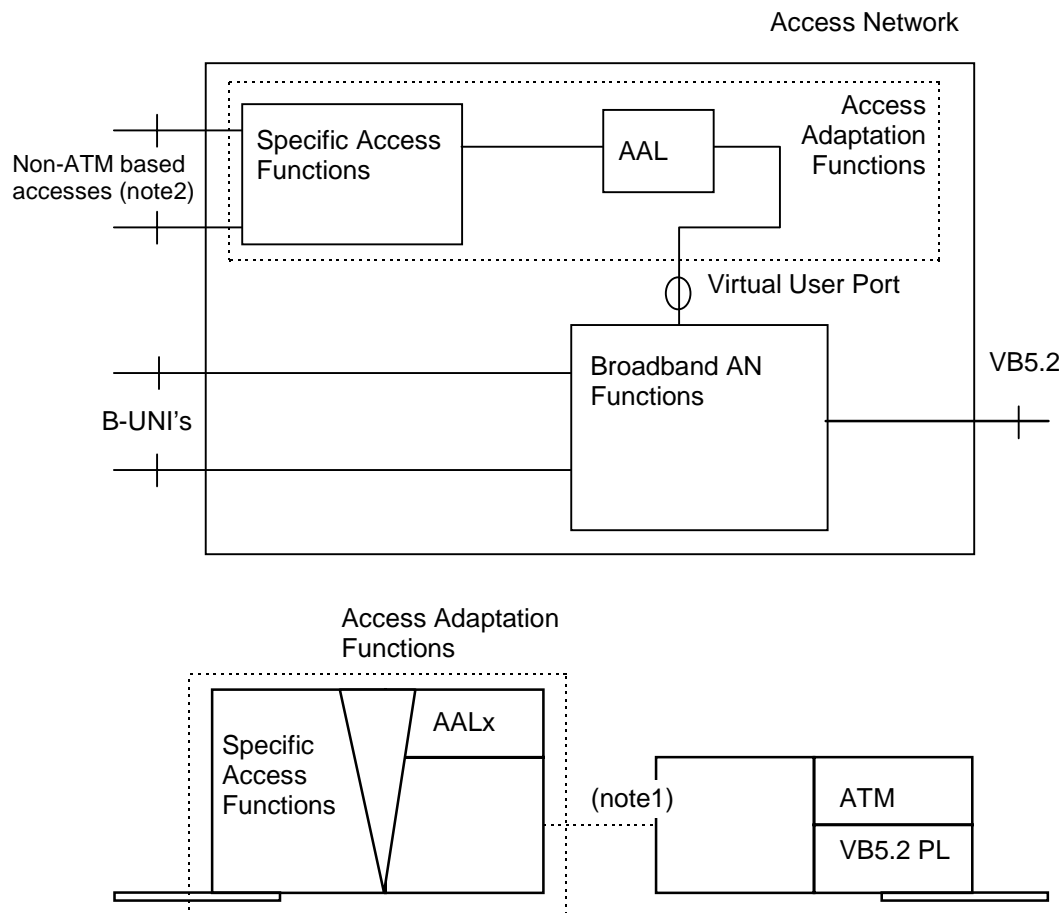

NOTE 1: Internal reference point representing the Virtual User Port, which is assumed to be ATM based.
 NOTE 2: Including narrowband accesses; these are further described in subclause 8.3.2.

Figure 8: User plane functionality and protocol stack for non-ATM based accesses

At the VB5.2 reference point, traffic from non-ATM based accesses will be supported via VCs. The associated VC connections are terminated within the AAFs. The other connection termination point can be located in the SN or further on in the network.

Within the AN there may or may not exist a connection point for this VC.

8.3.1.2 Control plane

The VC connection supporting the user plane traffic from non-ATM based accesses shall be on-demand or semi-permanent. Signalling originated in the AAF shall be treated as transparent data within the AN.

On-demand VC connections shall be established using the B-BCC protocol by the SN.

NOTE: VP connections may be established by provisioning between the SN and the AAF of the VUP to support switched VC connections. In this case, since the VC connections within the VP connection are transparent to the AN, (i.e. on the user side of the VUP) there are no VB5.2 control plane requirements, therefore the B-BCC is not used.

On demand VC connections are either allocated via B-ISDN user-to-network-signalling or by other means at the UNI. In the latter case, AAFs in the VUP may be used to generate DSS2 signalling towards the SN.

8.3.1.3 Management plane

AAFs may be required as part of management plane procedures (i.e. conversion to B-ISDN meta-signalling).

The introduction of the virtual user port does not preclude that non-ATM based, non-B-ISDN access specifics are managed via the Q3(AN) interface. i.e. the MIB of the AN should be extended for the AAL and the access specific functions.

The establishment of a semi-permanent VC connection, with one endpoint in the AAFs, shall be possible via the Q3(AN).

The establishment of a semi-permanent VC connections, with one endpoint in the AAFs, shall be possible via:

- co-ordinated provision using Q3(AN) and Q3(SN);
- Q3(SN) only in conjunction with the B-BCC to control an associated AN part of the connection.

Cross-connections within the AAF are outside the scope of the present document.

8.3.2 Analogue and 64 kbit/s based narrowband accesses as supported by V5 interfaces

Narrowband accesses as supported by the V5.1 and V5.2 interfaces are also supported via the VB5.2 reference point as specified in subclause 8.3.2 of EN 301 005-1 [1].

8.3.3 Other non-ATM based non-B-ISDN accesses

Other non-B-ISDN accesses are supported via the VB5.2 reference point as specified in subclause 8.3.3 of EN 301 005-1 [1].

9 Transfer and layer management functions

This clause covers the definition of the transfer and layer management functions to support services and includes a specification of a functional model of remote access arrangements with a VB5.2 reference point.

This specification does not preclude the realization of further transfer functions (i.e. additional cross-connections) within the AN. However, the behaviour from the UNI to the SNI is normative within the present document, i.e. from an SNI point of view a remote access arrangement with a VB5.2 reference point shall behave as if the functions in this clause were implemented.

9.1 General functional architecture

In figure 9 the application of the functional architecture for a general ATM network element as defined in ITU-T Recommendation I.731 [55] to remote access arrangements with a VB5.2 reference point is illustrated. It is based on the B-ISDN protocol reference model described in ITU-T Recommendation I.321 [18].

This divides the AN into functional areas as follows:

a) Transfer functions:

Transfer functions are mainly related to the lower layers of the B-ISDN protocol reference model (i.e. physical and ATM layer) and include all functions required for the transport of user, signalling, OAM and resource management information. The transfer functions are common for all higher layer services in B-ISDN.

ATM adaptation layer functions are considered as part of the transfer functions and are required to enable higher layer protocols (i.e. RTMC and B-BCC protocols) to use the service-independent ATM layer.

AAL functions in the AN are also required to provide for the transport of information from (non-ATM based) non-B-ISDN access types across the VB5.2 reference point.

b) Layer management functions:

Management information associated with a given transfer layer function is passed to (or received from) the corresponding layer management functions, i.e. for processing of configuration, fault monitoring, performance monitoring, UPC/NPC. Configuration, performance, fault, and accounting information may be passed to plane management for further processing and/or communication to external network management entities and/or operating systems. Layer management functional blocks correspond one-to-one with transfer functional blocks.

c) Plane management functions:

Plane management deals with the set of functions applicable to management of the network element as a whole or those functions related to the relationships with management systems external to the network element. It includes co-ordination between layer management entities.

Plane management includes the RTMC system. The RTMC system is responsible for the real time co-ordination between AN and SN across the reference point. Requirements for real time co-ordination are described in clause 11, structure and architecture of the VB5.2 RTMC system are specified in clause 13 of the present document.

d) B-BCC system:

The B-BCC system is the VB5.2 specific entity defined in the present document which provides the communication procedures for the SN to communicate requests to the AN to establish, modify and release the access connection element part of VCCs.

e) Timing functions:

these functions deal with the actions required to synchronize the equipment interfaces, either ATM based interfaces or non-ATM interfaces, to a clock source (i.e. network, external or internal).

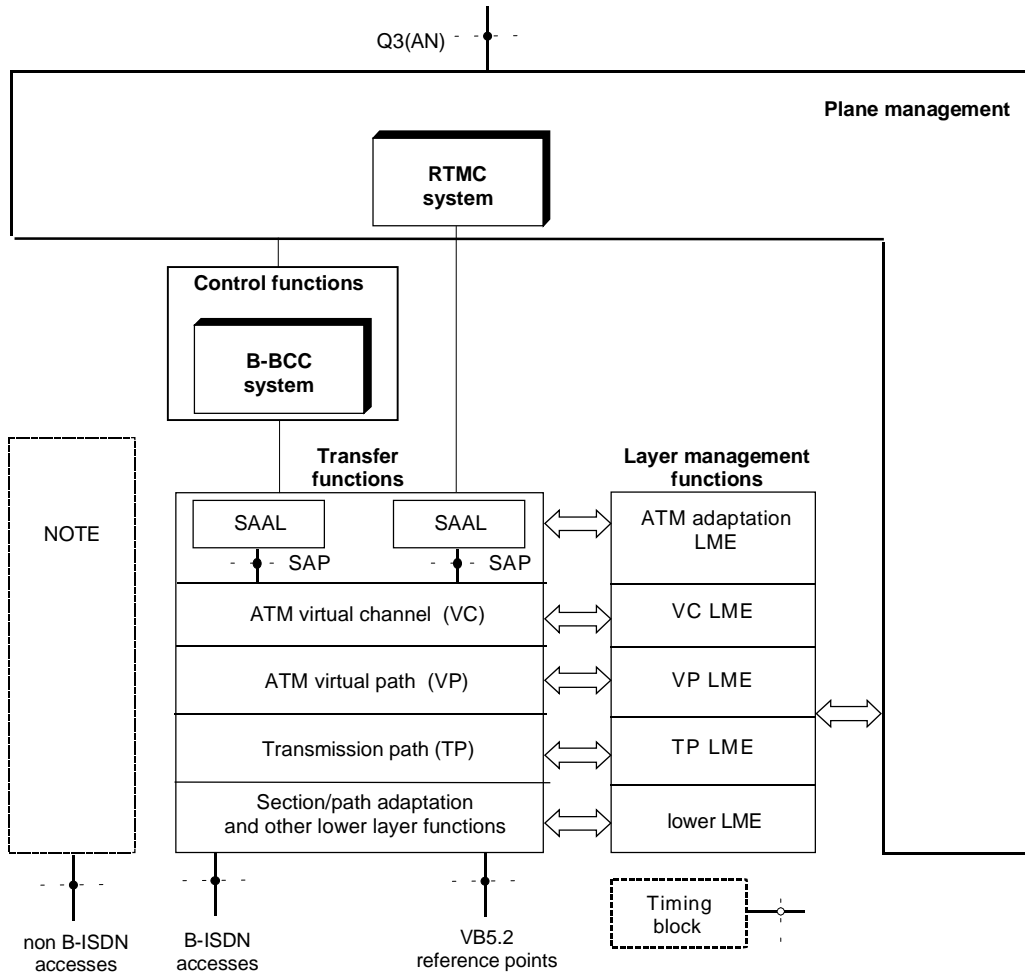

NOTE: AAFs to support non-B-ISDN access types. For specific non-B-ISDN access types, these functions include AAL functions. Other non-B-ISDN accesses may include only those transfer functions necessary to support a given user access.

Figure 9: General functional architecture of the AN

9.2 Functional architecture of transfer and layer management functions

The general functional architecture of the transfer functions within the AN and SN are illustrated in figure 10. This illustration is based on the protocol reference model representation as given in ITU-T Recommendation I.732 [27].

This functional description concentrates on the "edge functions" of the AN and SN in order to ensure interoperability with other equipment (i.e. customer premises equipment or transport network equipment).

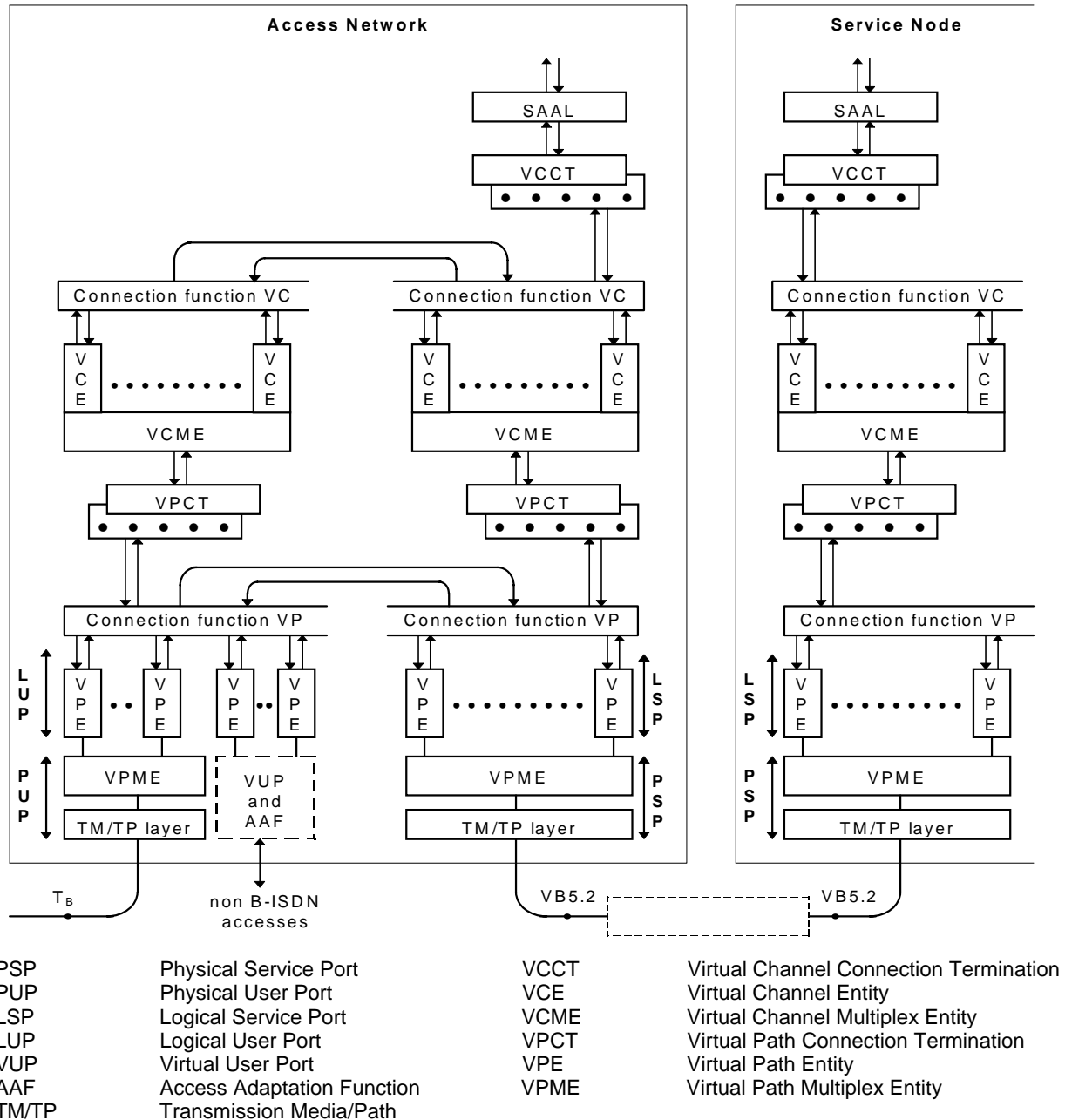

NOTE: The ATM connection function, used in conjunction with the VUP, is provided for modelling purposes and may not necessarily exist in practice.

Figure 10: Functional architecture of transfer functions in remote access arrangements

9.3 Transfer functions required for individual broadband AN connection types

In table 2 the subset of transfer (and layer management) functions required to support a specific broadband AN connection type (see clause 7 of the present document) is identified.

Table 2: Transfer functions for broadband AN connection types

Connection type (note)	User port side	Connection function	Service port side
B-ISDN connection types			
Type A-VP connections	VPE VPME TM/TP layer	VP connection entity	VPE VPME TM/TP layer
Type A-VC and C-VC connections	VCE VCME VPCT VPE VPME TM/TP layer	VC connection entity	VCE VCME VPCT VPE VPME TM/TP layer
Type B-VP connections			VPCT VPE VPME TM/TP layer
Type B-VC connections			VCCT VCE VCME VPCT VPE VPME TM/TP layer
Non-B-ISDN connection types			
Type D-VP connections	VPE VUP/AAF	VP connection entity	VPE VPME TM/TP layer
Type D-VC and E-VC connections	VCE VCME VPCT VPE VUP/AAF	VC connection entity	VCE VCME VPCT VPE VPME TM/TP layer
NOTE:	Specifications for transfer and layer management functions for connections with point-to-multipoint configuration are still under study within ITU-T. The impact of these specifications on the functions required for the broadband AN connection types requires further investigation.		

9.4 Functions associated with logical and physical ports

The ATM layer transfer functions associated with the following logical or physical ports shall be as defined in EN 301 005-1 [1]:

- Physical User Port (subclause 9.4);
- Logical User Port (subclause 9.5);
- Adaptation of non-B-ISDN access types (subclause 9.6);
- Connection functions (subclause 9.7);
- Physical Service Port (subclause 9.8);
- Logical Service Port (subclause 9.9).

NOTE: Although some connection types, additional to VB5.1 are provided in VB5.2, the transfer and layer management functions are the same, regardless of how the connections were established.

10 Provisioning principles and requirements

10.1 General

Provisioning is one of a number of aspects related to management plane functions. It has been separated from other management plane requirements because provisioning shall be performed through the Q3 interfaces of the AN and the SN and is therefore not directly relevant to the VB5.2 reference point specification. Only those provisioning aspects having at least conceptual or indirect implication to the reference point definition are defined below.

10.2 Provisioning principles common for the VB5.1 and VB5.2 reference point concept

The contents of this subclause are identical to subclause 10.2 of EN 301 005-1 [1], except for item h).

10.3 Provisioning principles specific for the VB5.2 reference point concept

This subclause defines additional provisioning principles and requirements which are specific for the VB5.2 reference point concept. In case of any ambiguities, these VB5.2 specific principles and requirements supplant the common principles defined in subclause 10.2.

a) Types of VPCs at the VB5.2 reference point:

For any given (provisioned) VPC at the VB5.2 reference point, one of four control scenarios shall apply:

- 1) The VPC is cross connected in the AN and the VCCs within the VPC are transferred transparently through the AN.
- 2) The VPC is exclusively used to support VCCs under control of Q3(AN) and Q3(SN) interfaces by means of co-ordinated provisioning.
- 3) The VPC is exclusively used to support VCCs under control of B-BCC procedures.
- 4) The VPC is used to support both VCCs under control of the Q3(AN) and Q3(SN) interfaces and VCCs under control of B-BCC procedures.

b) Types of VPCs at the UNI:

For any given (provisioned) VPC at the UNI, one of four control scenarios shall apply:

- 1) The VPC is cross connected in the AN and the VCCs within the VPC are transferred transparently through the AN.
- 2) The VPC is exclusively used to support VCCs under control of Q3(AN) and Q3(SN) interfaces by means of co-ordinated provisioning.
- 3) The VPC is exclusively used to support VCCs under control of B-BCC procedures.
- 4) The VPC is used to support both VCCs under control of the Q3(AN) and Q3(SN) interfaces and VCCs under control of B-BCC procedures.

c) Types of UNI accesses with regard to the support of switched VCCs:

For any given logical UNI access in the SN, switched VCCs shall be provided:

- using either VC links established on a per connection basis in the AN by means of the B-BCC functions (e.g., type C-VC broadband AN connections);
- or via VPCs cross connected in the AN (e.g., type A-VP broadband AN connections), in which case the B-BCC functions will not be used.

It shall not be possible to mix both types on the same logical UNI access in the SN. However, it shall be possible to mix both types on a single UNI by using more than one instance of the logical UNI access per UNI in the SN.

d) Provisioning of VCCs for the support of the RTMC and the B-BCC protocol:

In order to support the RTMC and the B-BCC protocol, a particular VPC and two particular VCCs within that VPC shall be provisioned at the VB5.2 reference point. There shall be no possibility of the RTMC and/or the B-BCC protocol performance being compromised by the transport of other multiplexed traffic at the VB5.2 reference point. The VPI value shall be in the range of 0 up to 4095, the VCI values shall be in the range of 32 up to 65535.

e) Co-ordinated provisioning for the support of B-BCC procedures:

The configuration management information given below shall be available in the AN and the SN in order to support the allocation, modification and deallocation of VCCs under control of B-BCC procedures:

- List of VPCIs associated to a given LUP.

This list shall include the following characteristic information related to the particular VPCs at the LUP:

- VCI range (i.e., number of allocated VCI bits);
- maximum number of simultaneously active VCCs;
- traffic descriptor and QoS of the individual VPCs.
- List of VPCIs associated to the VB5.2 reference point.

This list shall include the following characteristic information related to the particular VPCs at the LSP:

- VCI range (i.e., number of allocated VCI bits);
- maximum number of simultaneously active VCCs;
- traffic descriptor and QoS of the individual VPCs.

f) B-BCC protocol procedure for VPCI/VCI selection at the VB5.2 reference point:

For a given VB5.2 reference point, the B-BCC protocol shall operate in one of the following modes for the VPCI/VCI selection at the service port:

- 1) The exclusive mode where the SN indicates an exclusive VPCI value and an exclusive VCI value which shall be used by the AN to establish a VC link at the service port. Further details are described in subclause 11.2.2.1, scenario 1.
- 2) The non-exclusive mode where the SN indicates a preferred VPCI and a preferred VCI value (or, if only one VPC is available, an exclusive VPCI value and a preferred VCI value) which may be changed by the AN to establish a VC link at the service port. Further details are described in subclause 11.2.2.1, scenario 2.

In order to prevent potential VCI collisions, the SN shall not change the selection procedure on a per connection basis.

g) Propagation delay of VPCs at the VB5.2 reference point:

For each VPC at the VB5.2 reference point which is used to support VCCs under control of the B-BCC, the expected propagation delay shall be provisioned in the SN.

h) Propagation delay of VPCs at the UNI:

For each VPC at the UNI which is used to support VCCs under control of the B-BCC, the expected propagation delay shall be provisioned in the AN.

i) Counters and statistics related to the B-BCC function:

For further study.

11 Requirements for real-time co-ordination between AN and SN

This clause defines the requirements for real-time co-ordination between the AN and the SN across the VB5.2 reference point.

11.1 Principles and requirements for real-time management co-ordination (RTMC)

The contents of this subclause are identical to subclause 11.1 of EN 301 005-1 [1].

11.2 Principles and requirements for broadband bearer connection control (B-BCC)

11.2.1 General principles for B-BCC

The requirements for the B-BCC functions between the SN and the AN across the VB5.2 reference point are based on the principles given below.

a) Basic functionality.

The VB5.2 B-BCC function shall provide the means for the SN to request the AN to establish, modify and release VCCs between a logical user port and the VB5.2 reference point. This includes the support of point-to-multipoint VCCs with branching point inside the AN.

In case of point-to-point connections, both unidirectional and bi-directional user information transport is supported. In case of point-to-multipoint connections, only unidirectional user information transport in the direction from the VB5.2 reference point to the logical user ports is supported. However, this does not preclude the support of bi-directional point-to-multipoint connections by the SN using point-to-point connections in the AN.

Requirements for intra AN switching (i.e., support of VCCs between two logical user ports under control of the SN) are for further study. Intra AN switching may be realized without major changes to the basic principles of the VB5.2 reference point concept, however some major additions will be required (e.g., procedural, B-BCC based and others, as yet unidentified).

b) Application of the B-BCC function.

Resource management entities in the SN and the AN manage the resources involved in the support of bearer connections by means of the B-BCC function. Examples of resources are user ports, service ports, VPCIs and VCIs, bandwidth assigned to VPCs, etc. The resource management functions include connection admission control (CAC) functions.

The resource management entity in the SN may receive service requests from both the SN call/connection control function and the SN management function. The relationship between the resource management entities and the entities requesting B-BCC services is outside the scope of this Recommendation.

c) Support of user services.

The capabilities of the B-BCC functions shall be applicable for the support of different types of user services:

- Switched services, where the network shall allocate on-demand VCCs for the support of user calls.
- (Semi-)permanent leased line services, where a (semi-)permanent VCC is provided by means of on-demand VC links within the access connection element from the UNI to the SN. In this case, the SN shall handle the bearer connection established via the B-BCC as a (semi-)permanent connection rather than a switched connection.

11.2.2 Establishment of bearer connections

The B-BCC function provides the means for the SN to request the AN to establish a bearer connection within the AN. This connection is either a point-to-point connection or the root including the first branch of a point-to-multipoint connection. In both cases the bearer connection comprises a VC link at the user port, a VC link at the service port and the corresponding VC link interconnection between them.

The AN shall accept the connection request only when sufficient resources are available to establish the connection through the AN, to comply with the required QoS and to maintain the agreed QoS of existing connections. Otherwise the AN shall reject the connection request.

The following requirements have been defined:

11.2.2.1 Selection of VPCI and VCI at the service port

The B-BCC function shall support the scenarios summarized in table 3 and explained below:

- 1) The SN indicates an exclusive VPCI and an exclusive VCI within the VPC. The AN is requested to establish a VC link at the service port according to this data.
- 2) The SN indicates a preferred VPCI/VCI combination and may indicate a set of alternative VPCIs. The AN is requested:
 - to use the preferred VPCI/VCI combination;
 - or to use the preferred VPCI value and to select an available VCI value other than the preferred one;
 - or to select a VPCI from the indicated set and an available VCI within that VPC.

In case where the set of alternative VPCIs is empty, the AN cannot select an alternative VPCI but may still select another VCI value within the indicated VPC.

The AN shall report the selected VPCI and VCI back to the SN, and establish a VC link at the service port according to the selection.

This scenario allows the AN to finally assign the VPCI and VCI at the service port and may therefore improve the utilization of (limited) AN resources.

In order to benefit from the fact that the SN may reserve the resources required for the connection establishment (in the SN) according to the preferred VPCI/VCI combination, the AN should accept the preferred VPCI/VCI combination whenever possible. To have reserved the required SN resources for the preferred combination, the SN must have already performed the required CAC functions, and thereby must have determined that the requested connection can be admitted. Therefore, if the AN subsequently accepts the preferred VPCI/VCI combination, the connection request should always be successful.

Nevertheless, if the AN cannot accept the preferred VPCI/VCI combination and selects an alternative one, it is still expected that the connection request will finally be successful in most cases. However, that result cannot be guaranteed since the resources related to the VPCs at the VB5.2 reference point are shared amongst (many) users. It may happen that the required SN resources (related to the alternative combination) have been reserved or allocated for another connection while processing the first connection request in the AN. In this case, the CAC/resource manager function in the SN will ultimately reject the first connection request from the user and release the reserved resources in the AN.

Table 3: Scenarios for the selection of VPCI and VCI at the SNI

Scenario	Indication by the SN		Selection by the AN	
	VPCI at SNI	VCI at SNI	VPCI at SNI	VCI at SNI
1	exclusive VPCI	exclusive VCI	—	—
2	preferred VPCI and set of alternative VPCIs (NOTE)	preferred VCI within the preferred VPCI; no indication for the alternative VPCIs	choice	choice

NOTE: The set of alternative VPCIs may be empty. In this case the AN can only select the VCI value.

11.2.2.2 Selection of VPCI and VCI at the user port

The B-BCC function shall support the scenarios summarized in table 4 and explained below:

- 1) The SN indicates an exclusive VPCI and an exclusive VCI within the VPC. The AN is requested to establish a VC link at the user port according to this data.

This scenario shall be applied if only one VPC at the UNI is available (from the SN point of view) to establish the requested VC link at the user port.

- 2) The SN indicates a preferred VPCI/VCI combination and may indicate a set of alternative VPCIs. The AN is requested:
 - to use the preferred VPCI/VCI combination;
 - or to use the preferred VPCI value and to select an available VCI value other than the preferred one;
 - or to select a VPCI from the indicated set and an available VCI within that VPC.

In case where the set of alternative VPCIs is empty, the AN cannot select an alternative VPCI but may still select another VCI value within the indicated VPC.

The AN shall report the selected VPCI and VCI back to the SN, and establish a VC link at the user port according to the selection.

This scenario allows the AN to finally assign the VPCI and VCI at the user port and may therefore improve the utilization of (limited) AN resources. It shall be applied if more than one VPCI at the UNI is available (from the SN point of view) to establish the requested VC link at the user port.

For the use of the preferred VPCI/VCI combination the same arguments as for the allocation of VC links at the service port (see subclause 11.2.2.1) apply. However, the disadvantages that may occur when the AN selects an alternative combination are less severe, since, by definition, the VPCs at the UNI are not shared amongst different users.

NOTE: If B-BCC functions are used by the SN to support user calls under control of DSS2 procedures, scenario 2 may not be applicable. This is due to the optionality in the DSS2 procedures where the user may already indicate an exclusive VPCI or exclusive VPCI and VCI values.

Table 4: Scenarios for the selection of VPCI and VCI at the UNI

Scenario	Indication by the SN		Selection by the AN	
	VPCI at UNI	VCI at UNI	VPCI at UNI	VCI at UNI
1	exclusive VPCI	exclusive VCI	—	—
2	preferred VPCI and set of alternative VPCIs (NOTE)	preferred VCI within the preferred VPCI; no indication for the alternative VPCIs	choice	choice

NOTE: The set of alternative VPCIs may be empty. In this case the AN can only select the VCI value.

11.2.2.3 Bearer connection parameters

The SN shall indicate the connection parameters required for the establishment of the requested bearer connection to the AN. Examples for such connection parameters are:

- configuration (i.e. point-to-point or point-to-multipoint);
- ATM transfer capability;
- ATM traffic descriptor;
- quality of service.

This requirement includes the application of additional traffic parameters as defined in ITU-T Recommendations Q.2961 [29] and Q.2961.2 to Q.2961.6 [30], [31], [32], [33], [34].

The ATM transfer capabilities ABR and ABT as defined in EN 300 301 [6] / ITU-T Recommendation I.371 [44] only apply to point-to-point connections.

11.2.2.4 Negotiation of connection characteristics

The B-BCC function shall allow the negotiation of connection characteristics during the establishment phase of the bearer connection.

NOTE: This function can be used in conjunction with the negotiation of connection characteristics for calls/connections under control of user signalling procedures as specified in ITU-T Recommendation Q.2962 [35].

11.2.2.5 Branches of point-to-multipoint connections

The B-BCC function shall provide the means for the SN to request the AN to create an additional branch of an established point-to-multipoint bearer connection in the AN.

NOTE: This function can be used by the SN to support point-to-multipoint connections under control of user signalling procedures as specified in ITU-T Recommendation Q.2971 [38].

For the required selection of the VPCI and VCI at the user port to be connected via the additional branch, the scenarios specified in subclause 11.2.2.2 apply.

11.2.3 Release of bearer connections

The B-BCC function provides the means for the SN to request the AN to release resources allocated to a bearer connection in the AN. The following particular requirements have been defined:

- a) It shall be possible to release a (point-to-point or point-to-multipoint) bearer connection in the AN. In case of a point-to-multipoint connection, this shall include the entire connection, i.e. the root at the VB5.2 reference point and all branches of the connection in the AN.
- b) It shall be possible to release a particular branch of a point-to-multipoint connection in the AN. A release branch procedure that results in no branches remaining in the AN shall not be possible. The last branch shall be cleared via the connection release procedure, resulting in the release of the entire bearer connection in the AN.

11.2.4 Modification of traffic parameters of established bearer connections

The B-BCC function provides the means for the SN to request the AN to modify the traffic parameters of an established bearer connection.

This function only applies to point-to-point connections.

- NOTE: This function can be used by the SN in conjunction with the modification of traffic parameters under control of user signalling procedures as described in ITU-T Recommendations Q.2963.1 [36] and Q.2963.2 [37].

11.2.5 B-BCC reset

Over and above the procedures for bearer connection release, the B-BCC function provides the means to reset resources which are under control of the B-BCC to the idle condition. The reset function shall be used under abnormal conditions; for example, when an underlying resource as a physical port or a VPC has become unavailable or when the current status of VC links is unknown or ambiguous (e.g. after system re-start).

It shall be possible that the SN requests the AN to reset:

- a) all the resources which are under control of the B-BCC;
- b) those resources which have been allocated to VCCs carried in a particular VPC;
- c) those resources which have been allocated to a single VCC;
- d) those resources which have been allocated to a single VC link (at a user port or a service port).

11.2.6 Automatic congestion control

The automatic congestion control (at connection level) is responsible for supervising, limiting or reducing the number of connection requests handled simultaneously within the AN.

Based on the general behaviour of an automatic congestion control system described in ITU-T Recommendation E.412 [52], the following requirements are identified:

- a) The automatic congestion control procedure shall be asymmetrical: The AN (as the instance which accepts or rejects connection requests) shall indicate its congestion status to the SN (as the instance which generates the connection requests), but not vice versa.
- b) In the AN, thresholds shall be established so that two levels of congestion can be identified, with congestion level 2 indicating a more severe performance degradation than congestion level 1. When either level of congestion in the AN occurs, the AN shall have the capability to notify the SN of the change in its congestion status.
- c) When the SN receives a signal that indicates a congestion problem at the AN, the SN shall have the capability to reduce the number of connection requests sent to the AN.

The definition of appropriate thresholds and the detailed specification of the congestion levels in the AN is outside the scope of this Recommendation. This includes the behaviour of the AN if it is connected to more than one SN.

11.2.7 B-BCC start-up and B-BCC restart requirements

The functions at the VB5.2 reference point include procedures for a start-up and restart of the B-BCC protocol entities in the AN and the SN. These procedures can be initiated at the SN exclusively and can be triggered by the events shown in table 5.

Table 5: Scenarios for initiation of B-BCC start-up and B-BCC restart

Trigger event	B-BCC start-up	B-BCC restart
B-BCC start-up request from SN operator	√	not applicable
Indication from SAAL instance that the SAAL for the B-BCC protocol has been established by the AN	√ (note)	√ (note)
Failure of the SAAL for the B-BCC protocol	√ (note)	√ (note)
NOTE: If bearer connections can be retained from an SN point of view, the SN shall initiate a B-BCC restart. Otherwise the SN shall initiate a B-BCC start-up.		

11.2.7.1 B-BCC start-up

The start-up of the B-BCC protocol entities can be initiated at the SN:

- by the SN operator (i.e. operator requested B-BCC start-up);
- or automatically by the SN on receipt of an indication that the SAAL for the B-BCC protocol has been established by the AN (i.e. automatic B-BCC start-up);
- or automatically by the SN when a failure of the SAAL instance of the B-BCC protocol has occurred.

The B-BCC start-up procedure shall comprise the following steps:

- a) Establishment of the SAAL for the B-BCC protocol.
This action applies only if the SAAL is not yet established.
- b) Reset of the B-BCC protocol entities in the SN and AN to the idle state (i.e., all bearer connections which are under control of the B-BCC are cleared).

After the B-BCC reset has been performed, the B-BCC start-up is completed and the B-BCC function is fully operable.

11.2.7.2 B-BCC restart

The restart of the B-BCC protocol entities can be automatically initiated by the SN:

- either when a failure of the SAAL instance of the B-BCC protocol has occurred;
- or on receipt of an indication that the SAAL for the B-BCC protocol has been established by the AN.

The B-BCC restart procedure shall include the following steps:

- a) Establishment of the SAAL for the B-BCC protocol.
This action applies only if the SAAL is not yet established.
- b) B-BCC pre-synchronization.

The SN shall initiate a procedure to check whether the bearer connections are still available from an AN point of view.

If the AN has retained the bearer connections, a reset of the B-BCC protocol entities to the idle state is not necessary. The B-BCC restart is completed and the B-BCC function is fully operable.

In order to synchronize the B-BCC protocol entities at both sides of the VB5.2 reference point, the SN shall ultimately initiate the release of those bearer connections in the AN which shall not or cannot be maintained from an SN point of view.

In particular, the following bearer connections shall be released:

- Connections which have been cleared in the SN due to user-to-network signalling procedures or any other external events during the period where the B-BCC communication procedures were disabled.
- Connections where a B-BCC transaction was in progress when the interruption of the B-BCC communication procedures occurred.

c) B-BCC reset.

If the AN has not retained the bearer connections, the SN shall initiate a B-BCC reset of the B-BCC protocol entities in the SN and AN to the idle state (i.e., all bearer connections which are under control of the B-BCC are cleared).

After the B-BCC reset has been performed, the B-BCC restart is completed and the B-BCC function is fully operable.

11.2.7.3 Indirect initiation of a B-BCC start-up or restart at the AN

Although a B-BCC start-up and the B-BCC restart can not be directly initiated at the AN, the AN may indirectly trigger a B-BCC start-up or B-BCC restart at the SN by establishing the SAAL of the B-BCC protocol.

At the AN, the establishment of the SAAL of the B-BCC protocol entities shall be initiated:

- either by the AN operator;
- or automatically within the AN, when a failure of the SAAL instance of the B-BCC protocol has occurred.

The SN, when receiving the indication from the SAAL instance that the SAAL for the B-BCC protocol has been established by the AN, shall then initiate a B-BCC start-up or restart as illustrated in table 5.

11.2.8 Procedural requirements

For the B-BCC function the following procedural requirements apply:

a) Response to requests.

In response to a request received from the SN, the AN shall notify the SN whether the requested action has been successfully performed. If the requested action could not be performed, the AN shall inform the SN about the reason for the rejection (i.e., available bandwidth insufficient, AN internal fault, etc.).

b) Identification of bearer connections.

A bearer connection shall be identified by a connection reference number which shall be assigned by the SN and be maintained during the lifetime of the connection. The connection reference number shall be unique within the LSP (i.e. VB5.2 reference point).

In case of a point-to-multipoint connection, the connection reference number shall identify the root and the branches of the connection as a whole.

c) Identification of branches of point-to-multipoint bearer connections.

A branch of a point-to-multipoint connection within the AN shall be identified by a branch identifier which shall be assigned by the SN and maintained the lifetime of the branch. The branch identifier shall be unique within a bearer connection instance (i.e. connection reference number).

d) Release of a set of bearer connections.

It shall be possible to release a set of bearer connections via a single B-BCC request.

- e) Release of a set of branches.

It shall be possible to release a set of branches of a given point-to-multipoint bearer connection via a single B-BCC request.

12 Performance design objectives

Two distinct performance areas are identified:

- a) Transfer functions - concerned with the transfer of user signalling and data via the interface.
- b) RTMC functions - concerned with the real-time management of the interface.

12.1 Performance design objectives for transfer functions

ANs supporting the VB5.1 reference point carry ATM cells between the UNI and SNI in VCCs which do not terminate in the AN. The factors affecting the transfer of these cells are related directly to the performance of the transmission systems and connection functions in the AN.

ATM layer cell transfer performance requirements are defined in ITU-T Recommendation I.356 [19], in particular:

- cell transfer delay;
- cell delay variation;
- cell error ratio;
- cell loss ratio;
- cell misinsertion rate.

12.2 Performance design objectives for RTMC and B-BCC functions

For further study.

13 VB5.2 system architecture, structure and procedures

13.1 Introduction and overview

The description of the VB5.2 system architecture, structure and procedures are based on the specification model given in figure 11.

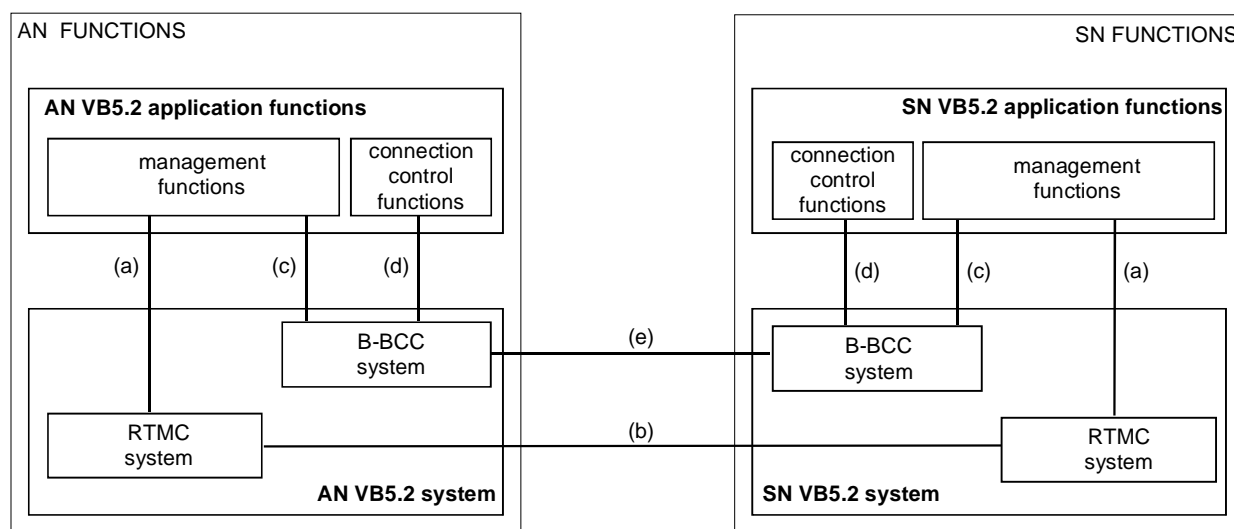

- (a) Service primitives between management functions and RTMC system
 (b) RTMC protocol messages across the VB5.2 reference point
 (c) Service primitives between management functions and B-BCC system
 (d) Service primitives between connection control functions and B-BCC system
 (e) B-BCC protocol messages across the VB5.2 reference point

Figure 11: Overall VB5.2 system specification model

The VB5.2 specific functionality in the AN and the SN is subdivided into two main parts:

- a) The set of VB5.2 application functions which provide the required real-time co-ordination between the AN and the SN. The VB5.2 application functions represent the VB5.2 related part of the set of application functions in the AN and SN, respectively.

Two groups of VB5.2 application functions are identified:

- 1) VB5.2 management functions.

The VB5.2 management functions comprise the following particular functions.

- the RTMC functions as specified in EN 301 005-1 [1] and ITU-T Recommendation Q.832.1 [47]. These functions use the communication procedures provided by the RTMC system.
- the management functions which trigger the start-up and restart of B-BCC protocol. These functions use communication procedures provided by the B-BCC system.

- 2) VB5.2 connection control functions.

The VB5.2 connection control functions enable the establishment, modification and release of bearer connections in the AN as described in subclause 13.5. They also include maintenance functions such as reset and automatic congestion control. These functions use communication procedures provided by the B-BCC system.

- b) The VB5.2 system which contains the RTMC system and the B-BCC system. It provides the communication capabilities required by the VB5.2 application functions.

The RTMC and the B-BCC system are specified as separate systems. Each of these systems communicates via messages with its peer entity and communicates via service primitives with its "environment" inside the network element. The functions summarized by the term "environment" depend on the particular system as described below:

- From the RTMC system point of view, the environment is represented by the RTMC related part of the management application functions.
- From the B-BCC system point of view, the environment is represented by the VB5.2 connection control functions and the B-BCC related part of the management application functions.

There are interactions between the management application functions and the connection control functions, e.g., in case of remote blocking of a VPC which is used for VCCs under control of the B-BCC. In order to facilitate the required interactions, the application functions of the relevant network element (AN or SN) are assumed to perform the appropriate network element internal co-ordination functions.

The following subclauses describe the RTMC and the B-BCC system in two ways. First the static protocol architecture is (see subclauses 13.2 and 13.4), then the dynamic behaviour is described (see subclauses 13.3 and 13.6). The description of the dynamical aspects of the B-BCC include an illustration of how the VB5.2 connection control functions including the related maintenance functions shall use the services provided by the B-BCC system (see subclause 13.5).

The static structure is presented in terms of SDL system and block diagrams. The dynamic behaviour is presented by prose text, describing the principles of the procedures and how the procedures are embedded in their environment, and by message sequence charts which are used to illustrate the basic procedures of the VB5.2 protocols (see subclauses 13.3 and 13.6). Finally the lowest level of the SDL hierarchy, the process diagrams, describe the procedures in full detail. They can be found in annex A.

The behaviour represented by the SDL description plus the set of primitives which drive them should be followed exactly as described. However, no specific implementation is implied by the specification language employed. It is the functionality represented within clauses 13 and 14 and annex A which defines the VB5.2 system. In the case of ambiguities between text and process diagrams, the diagrams take precedence.

13.2 RTMC system architecture

The contents of this subclause are identical to subclause 13.2 of EN 301 005-1 [1].

13.3 RTMC procedures

The contents of this subclause are identical to subclause 13.3 of EN 301 005-1 [1].

13.4 B-BCC system architecture

13.4.1 System diagrams

Within this subclause the B-BCC system architecture will be specified. The B-BCC system architecture identifies the functional entities which support the communication of B-BCC messages via the VB5.2 reference point.

13.4.1.1 Overview of B-BCC system

An overview showing the basic functional blocks for the B-BCC system at AN and SN side is provided by figure 12. Each B-BCC system communicates with the relevant B-BCC application functional entities via the MEE and CEE primitive interfaces. The B-BCC application functions are described in subclause 13.5. B-BCC messages are passed to the SAAL via DATA primitives. For the B-BCC protocol specification reference is made to the messages only between the protocol entities.

An individual B-BCC system comprises entities at management level (e.g. for establishment of SAAL connection), at connection level (e.g. for checking the validity of a message in a certain state) and at protocol transport level (e.g. for sending/receiving B-BCC messages).

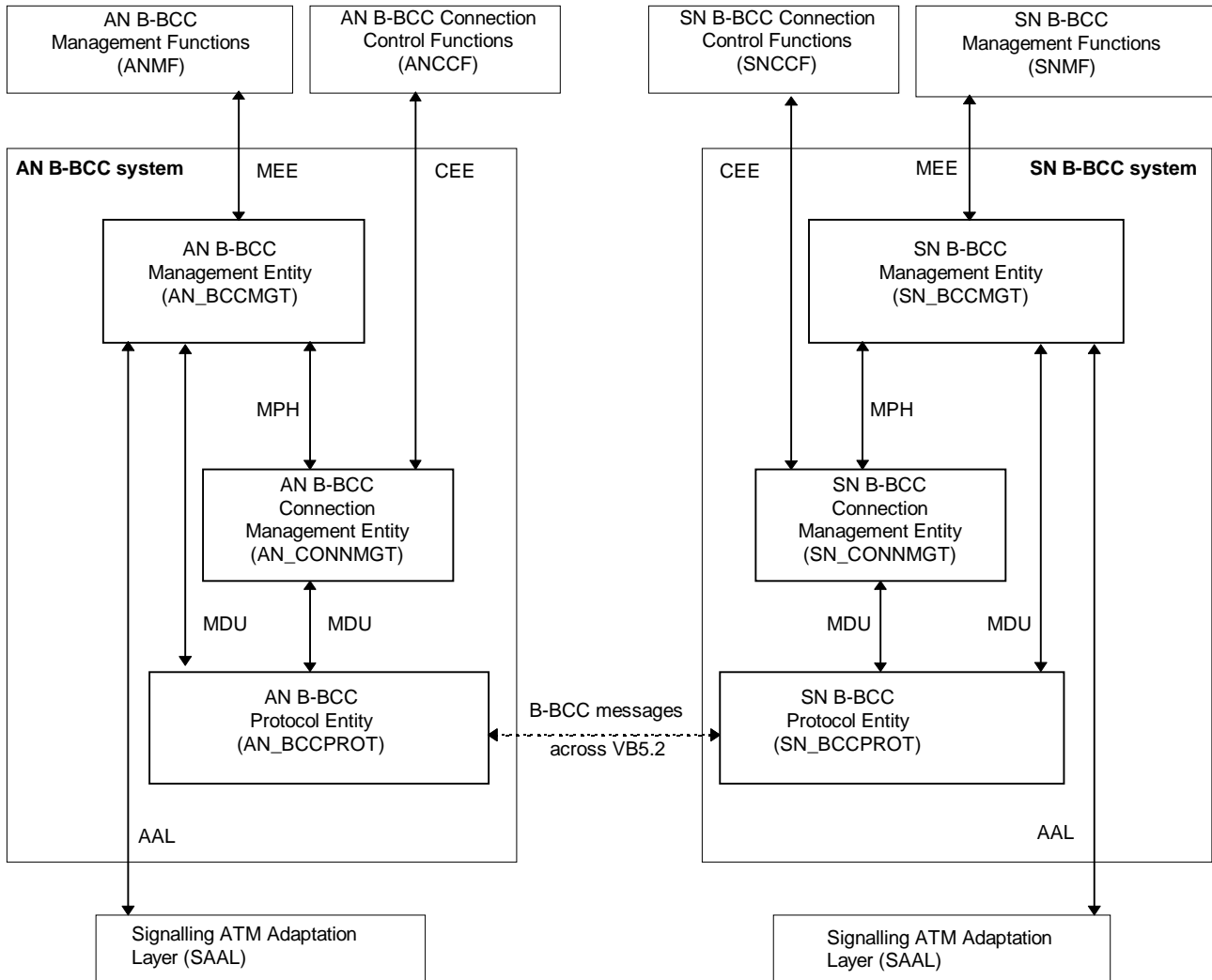

NOTE 1: The abbreviations shown at the arrows are classes of primitives used by B-BCC protocol (see table 6).

NOTE 2: B-BCC messages are passed to the SAAL SAP via DATA primitives. For the B-BCC protocol specification reference is made to the messages only.

Figure 12: B-BCC system overview

13.4.1.2 Classification of B-BCC primitives

B-BCC primitives represent, in an abstract way, the exchange of information and control between functional entities within an individual B-BCC system. They do not specify or constrain implementation. Table 6 classifies the introduced primitives.

Table 6: Naming conventions for B-BCC primitives

Primitive classes	Prefix
Primitives between the B-BCC management entity and signalling ATM adaptation layer SAAL	AAL
Primitives between B-BCC management entity or connection management entity and B-BCC protocol entity	MDU
Primitives between AN/SN B-BCC system and the connection control application function	CEE
Primitives between AN/SN B-BCC system and the management application function	MEE
Primitives between B-BCC management entity and connection management entity	MPH

13.4.1.3 B-BCC system (AN side)

This subclause presents the decomposition of the B-BCC system into functional entities at the AN side. Each functional entity defined in this subclause comprises a number of processes. These processes are defined in subclause 13.4.2.

The functional entities composing an AN B-BCC system are shown in figure 13 and further defined in table 7.

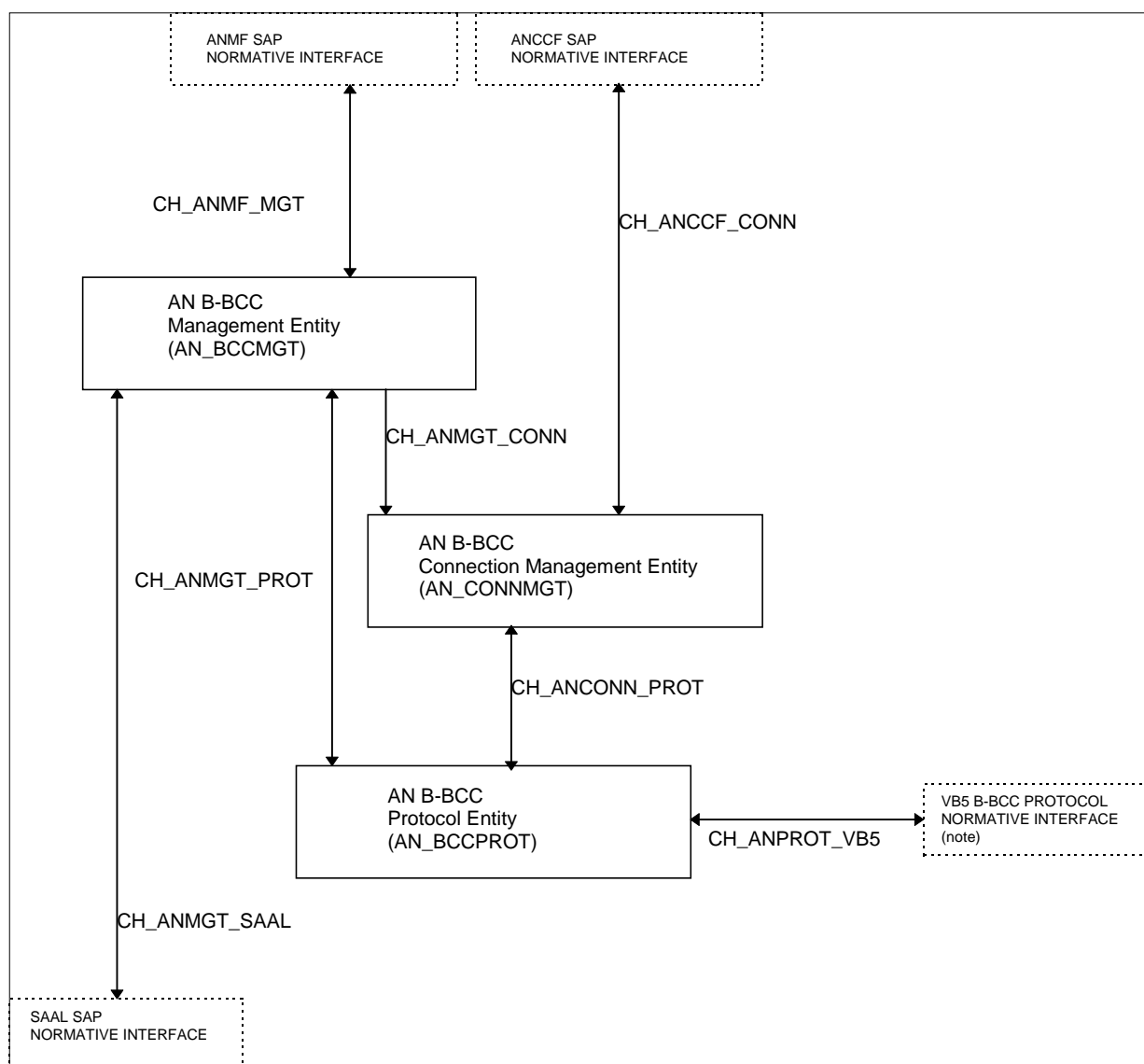

NOTE: B-BCC messages are passed to the SAAL SAP via DATA primitives. For the B-BCC protocol specification reference is made to the messages only.

Figure 13: AN B-BCC system

Table 7: AN functional entities

Functional entity (see figure 13)	Purpose
AN B-BCC Management Entity (AN_BCCMGT)	The AN B-BCC management entity represents the co-ordination function of the B-BCC system at the AN side. It shall support the B-BCC start-up and the pre-sync procedure. During interface start-up the AN system management shall request the SAAL establishment for the B-BCC protocol.
AN B-BCC Connection Management Entity (AN_CONNMGT)	The AN B-BCC connection management entity supports the establishment, modification and release of connections. It provides for the dynamic creation of connection status FSMs which shall reflect the status of individual connections. In addition, it supports the B-BCC reset procedure. During connection establishment/modification/release the B-BCC connection management shall supervise the message flow and assure that the AN B-BCC application entity receives only messages which fit into the context of that connection, cope with repeated messages from SN side.
AN B-BCC Protocol Entity (AN_BCCPROT)	The B-BCC protocol entity terminates the B-BCC protocol and shall build up the B-BCC protocol messages, supervise message transmission by timers, (note) re-transmit messages on timer expiration. (note)

NOTE: Only applied to invoking messages but not for acknowledgements.

The functional entities are connected via channels on which messages and primitives are conveyed. The channels are defined in table 8.

Table 8: Channels in the AN B-BCC system

Channel	Abbreviation in figure 13	Purpose/comments
AN Management Function ⇔ AN B-BCC Management Entity	CH_ANMF_MGT	Via this channel the AN management function entity shall trigger the start-up and shut-down of the B-BCC system, e.g. the establishment of the SAAL for the B-BCC protocol. Via this channel the AN management function entity shall be informed about general error situations within the B-BCC protocol entity.
AN Connection and Control Function ⇔ AN B-BCC Connection Management Entity	CH_ANCCF_CONN	Via this channel the B-BCC connection management entity shall inform the ANCCF about the establishment/modification/release of bearer connections as well as the B-BCC reset of resources.
AN B-BCC Management Entity ⇔ AN SAAL	CH_ANMGT_SAAL	Via this channel the B-BCC management entity shall trigger the establishment/release of the SAAL for the B-BCC protocol.
AN B-BCC Management Entity ⇔ AN B-BCC Protocol Entity	CH_ANMGT_PROT	Via this channel the B-BCC management entity shall trigger the AN B-BCC protocol entity to send messages to the SN. The B-BCC protocol entity shall inform AN B-BCC management entity about receipt of messages from the SN.
AN B-BCC Management Entity ⇔ AN B-BCC Connection Management Entity	CH_ANMGT_CONN	Via this channel the B-BCC management entity shall inform the B-BCC connection management entity about system start-up.
AN B-BCC Connection Management Entity ⇔ AN B-BCC Protocol Entity	CH_ANCONN_PROT	Via this channel the B-BCC connection management entity shall trigger the B-BCC protocol entity to send messages to the SN. The B-BCC protocol entity shall inform B-BCC connection management entity about receipt of messages from the SN.
AN B-BCC Protocol Entity ⇔ VB5 reference point	CH_ANPROT_VB5	Via this channel the B-BCC protocol entity sends/receives B-BBC messages to/from the SN. (note)
NOTE: The underlying SAAL is not taken into account.		

13.4.1.4 B-BCC system (SN side)

This subclause presents the decomposition of the B-BCC system into functional entities at the SN side. Each functional entity defined in this subclause comprises a number of processes. These processes are defined as SDL block diagrams in subclause 13.4.2.

The functional entities composing an SN B-BCC system are shown in figure 14 and further defined in table 9.

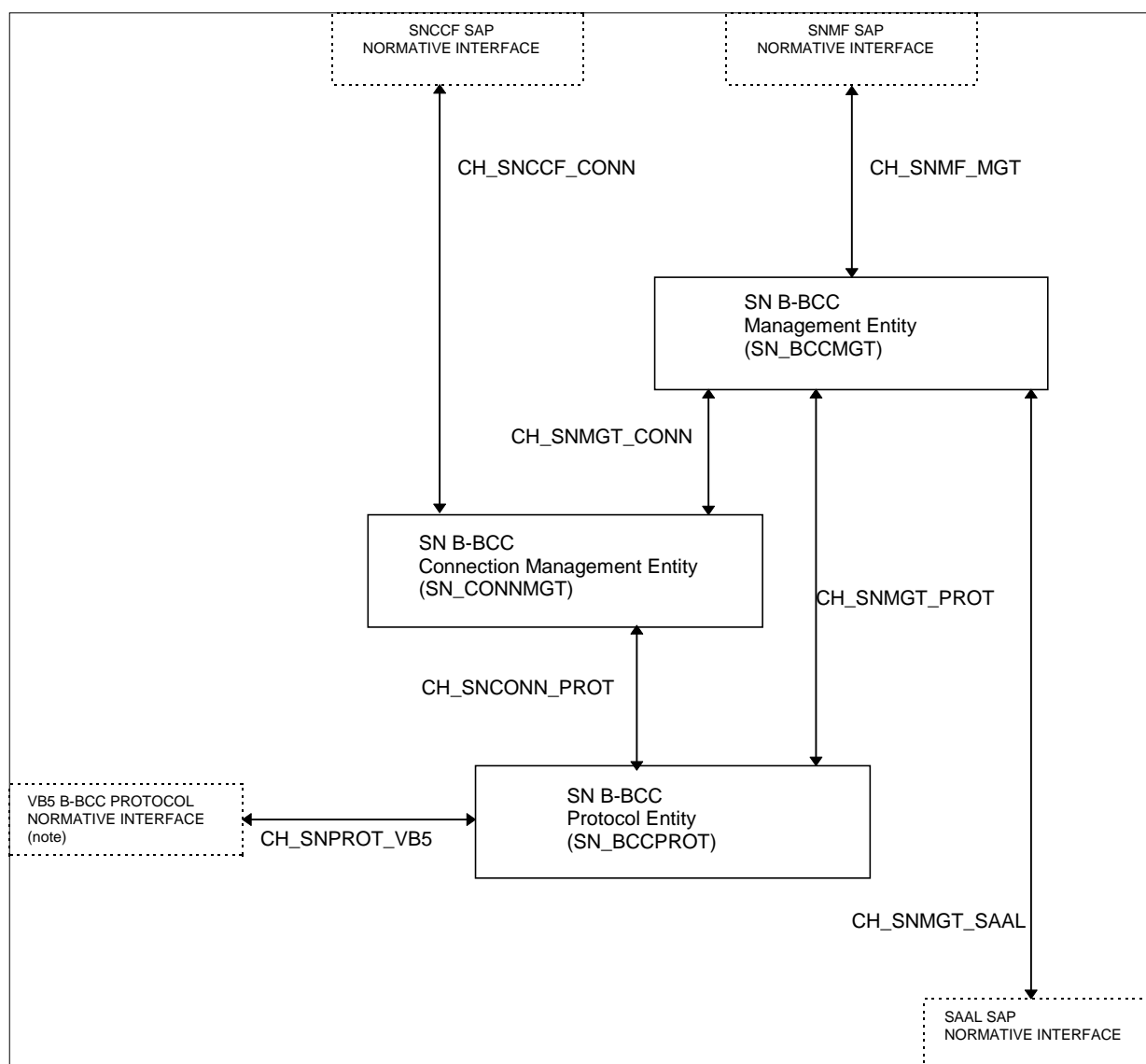

NOTE: B-BCC messages are passed to the SAAL SAP via DATA primitives. For the B-BCC protocol specification reference is made to the messages only.

Figure 14: SN B-BCC system

Table 9: SN functional entities

Functional entity (see figure 14)	Purpose
SN B-BCC Management Entity (SN_BCCMGT)	The SN B-BCC management entity represents the co-ordination function of the B-BCC system at the AN side. It shall support the B-BCC start-up, restart and pre-sync procedures. During interface start-up the AN system management shall request the SAAL establishment for the B-BCC protocol and trigger the reset procedure. During interface restart the AN system management shall request the SAAL establishment for the B-BCC protocol and trigger the pre-sync and reset procedure, if necessary.
SN B-BCC Connection Management Entity (SN_CONNMGT)	The SN B-BCC connection management entity supports the establishment, modification and release of connections. It provides for the dynamic creation of connection status FSMs which shall reflect the status of individual connections. In addition, it supports the B-BCC reset procedure. During connection establishment/modification/release the B-BCC connection management shall cope with overlap sending of messages
SN B-BCC Protocol Entity (SN_BCCPROT)	The B-BCC protocol entity terminates the B-BCC protocol and shall: <ul style="list-style-type: none"> – build up the B-BCC protocol messages, – supervise message transmission by timers, (note) – re-transmit messages on timer expiration. (note)
NOTE: Only applied to invoking messages but not for acknowledgements.	

The functional entities are connected via channels on which messages and primitives are conveyed. The channels are defined in table 10.

Table 10: Channels in the SN B-BCC system

Channel	Abbreviation in figure 14	Purpose/comments
SN management function ⇔ SN B-BCC management entity	CH_SNMF_MGT	Via this channel the SNMF entity shall trigger the start-up and shut-down of the B-BCC system, e.g. the establishment of the SAAL for the B-BCC protocol. Via this channel the SNMF entity shall be informed about general error situations within the protocol entity.
SN connection/control function ⇔ SN B-BCC connection management entity	CH_SNCCF_CONN	Via this channel the SNCCF entity shall trigger the establishment/modification/release of bearer connections as well as the B-BCC reset of resources.
SN B-BCC management entity ⇔ SN SAAL	CH_SNMGT_SAAL	Via this channel the B-BCC management entity shall trigger the establishment/release of the SAAL for the B-BCC protocol.
SN B-BCC management entity ⇔ SN B-BCC protocol entity	CH_SNMGT_PROT	Via this channel the B-BCC management entity shall trigger the SN B-BCC protocol entity to send messages to the peer entity. The B-BCC protocol entity shall inform SN B-BCC management entity about receipt of messages from the peer entity.
SN B-BCC management entity ⇔ SN B-BCC connection management entity	CH_SNMGT_CONN	Via this channel the B-BCC management entity shall inform the connection management entity about system start-up and trigger the reset of connection status FSMs.
SN B-BCC connection management entity ⇔ SN B-BCC protocol entity	CH_SNCONN_PROT	Via this channel the B-BCC connection management entity shall trigger the SN B-BCC protocol entity to send messages to the SN. The B-BCC protocol entity shall inform SN B-BCC connection management entity about receipt of messages from the SN
SN B-BCC protocol entity ⇔ VB5.2 reference point	CH_SNPROT_VB5	Via this channel the B-BCC protocol entity sends/receives B-BCC messages to/from the peer entity (note)
NOTE: The underlying SAAL is not taken into account.		

13.4.1.5 Primitive interface between B-BCC system and the VB5.2 application functions

This subclause provides the definitions for the MEE and CEE primitive interfaces with respect to the B-BCC system. No attributes are defined for the primitives due to the fact that this will depend on the actual implementation. The primitives which are common for both network elements are listed in subclause 13.4.1.5.1. The primitives which are specific for either the AN or the SN are listed in subclauses 13.4.1.5.2 and 13.4.1.5.3, respectively.

13.4.1.5.1 Primitives common for the AN and SN

meeBbccStartTrafficInd

spontaneous indication of the B-BCC system that the SAAL connection has been established. At the AN side the B-BCC protocol FSMs are set to state "in service". If the primitive is received in the SN the SN shall issue a meeBbccStartupReq or meeBbccRestartReq primitive to initialize the start-up or restart of the B-BCC system.

meeBbccStopTrafficReq

request to release the SAAL connection to the peer side and to put the local B-BCC protocol system FSMs in state "out of service".

meeBbccStopTrafficInd

spontaneous indication of a release of the SAAL connection.

meeBbccStopTrafficConf

response to meeBbccStopTrafficReq confirming that the local B-BCC protocol system FSMs are put in state "out of service".

meeBbccErrorInd

spontaneous indication of a detected protocol error.

13.4.1.5.2 Primitives specific for the SN**ceeAllocReq**

primitive is used by the SN to request the allocation of a bearer connection in the AN.

ceeAllocAccConf

response to primitive ceeAllocReq indicating that the AN has accepted the allocation request.

ceeAllocRejConf

response to primitive ceeAllocReq indicating that the AN has rejected the allocation request.

ceeAllocCompReq

primitive is used by the SN to request to complete the allocation of a bearer connection in the AN.

ceeAllocCompAccConf

response to primitive ceeAllocCompReq indicating that the AN has successfully completed the allocation request.

ceeAllocCompRejConf

response to primitive ceeAllocCompReq indicating that the AN has not successfully completed the allocation request.

ceeModifyReq

primitive is used by the SN to request the modification of a bearer connection in the AN.

ceeModifyAccConf

response to primitive ceeModifyReq indicating that the AN has accepted the modification request.

ceeModifyRejConf

response to primitive ceeModifyReq indicating that the AN has rejected the modification request.

ceeModifyCompReq

primitive is used by the SN to request to complete the update of traffic parameters of a bearer connection in the AN.

ceeModifyCompAccConf

response to primitive ceeModifyCompReq indicating that the AN has successfully updated the traffic parameters.

ceeModifyCompRejConf

response to primitive ceeModifyCompReq indicating that the AN has rejected the update of traffic parameters.

ceeModifyAbortReq

primitive is used by the SN to abort the update of traffic parameters of a bearer connection in the AN.

ceeModifyAbortAccConf

response to primitive ceeModifyAbortReq indicating that the AN has successfully aborted the update of the traffic parameters.

ceeModifyAbortRejConf

response to primitive ceeModifyAbortReq indicating that the AN has rejected the abort of update of traffic parameters.

ceeDeallocReq

primitive is used by the SN to request the de-allocation of a bearer connection in the AN.

ceeDeallocAccConf

response to primitive ceeDeallocReq indicating that the AN has de-allocated the bearer connection.

ceeDeallocRejConf

response to primitive ceeDeallocReq indicating that the AN has rejected the de-allocation of the bearer connection.

ceeAnFaultInd

primitive is used to indicate that in the AN a fault with regard to the bearer connection has been detected.

ceeAddBranchReq

primitive is used by the SN to request the allocation of an additional branch to a point-to-multipoint bearer connection in the AN.

ceeAddBranchAccConf

response to primitive ceeAddBranchReq indicating that the AN has accepted the allocation request.

ceeAddBranchRejConf

response to primitive ceeAddBranchReq indicating that the AN has rejected the allocation request.

ceeUpdateBranchReq

primitive is used by the SN to request to update the allocation of a branch to a PM bearer connection in the AN.

ceeUpdateBranchAccConf

response to primitive ceeUpdateBranchReq indicating that the AN has successfully updated the allocation request.

ceeUpdateBranchRejConf

response to primitive ceeUpdateBranchReq indicating that the AN has rejected the update of the allocation request.

ceeDropBranchReq

primitive is used by the SN to request the deletion of a branch of a point-to-multipoint bearer connection in the AN.

ceeDropBranchAccConf

response to primitive ceeDropBranchReq indicating that the AN has accepted the deletion request.

ceeDropBranchRejConf

response to primitive ceeDropBranchReq indicating that the AN has rejected the deletion request.

ceeBbccResetReq

primitive is used by the SN to request the reset of resources in the AN, i.e. the relevant bearer connections in the AN.

ceeBbccResetAccConf

response to primitive ceeBbccResetReq indicating that the AN has accepted the reset request.

ceeBbccResetRejConf

response to primitive ceeBbccResetReq indicating that the AN has rejected the reset request.

meeBbccStartupReq

request to invoke the B-BCC start-up procedure in the SN.

meeBbccStartupConf

response to meeBbccStartupReq confirming that the start-up procedure has been completed (success/failed). If the start-up was successful, the B-BCC protocol system is operational.

meeBbccRestartReq

request to invoke the B-BCC restart procedure in the SN.

meeBbccRestartConf

response to meeBbccRestartReq confirming that the restart procedure has been completed (success/failed).

meeBbccStartResetInd

spontaneous primitive during system start-up indicating that an autonomous reset procedure has been started.

13.4.1.5.3 Primitives specific for AN

ceeAllocInd

primitive is used to indicate a request from the SN for the allocation of a bearer connection.

ceeAllocAccRes

response to primitive ceeAllocInd indicating that the allocation request has been accepted.

ceeAllocRejRes

response to primitive ceeAllocInd indicating that the allocation request has been rejected.

ceeAllocCompInd

primitive is used to indicate a request from the SN to complete the allocation of a bearer connection.

ceeAllocCompAccRes

response to primitive ceeAllocCompInd indicating that the allocation request has been successfully completed.

ceeAllocCompRejRes

response to primitive ceeAllocCompInd indicating that the allocation request has not been successfully completed.

ceeModifyInd

primitive is used to indicate a SN request for the modification of a bearer connection.

ceeModifyAccRes response to primitive ceeModifyInd indicating that the modification request has been accepted.

ceeModifyRejRes

response to primitive ceeModifyInd indicating that the modification request has been rejected.

ceeModifyCompInd

primitive is used to indicate a request from the SN for updating a bearer connection.

ceeModifyCompAccRes

response to primitive ceeModifyCompInd indicating that the traffic parameters have been successfully updated.

ceeModifyCompRejRes

response to primitive ceeModifyCompInd indicating that the update of traffic parameters has been rejected.

ceeModifyAbortInd

primitive is used to indicate a request from the SN to abort the update of a bearer connection.

ceeModifyAbortAccRes

response to primitive ceeModifyAbortInd indicating that the update of traffic parameters has been aborted successfully.

ceeModifyAbortRejRes

response to primitive ceeModifyAbortInd indicating that the abort of update of traffic parameters has been rejected.

ceeDeallocInd

primitive is used to indicate a request from the SN for the de-allocation of a bearer connection.

ceeDeallocAccRes

response to primitive ceeDeallocInd indicating that the bearer connection has been de-allocated.

ceeDeallocRejRes

response to primitive ceeDeallocInd indicating that the bearer connection has not been de-allocated successfully.

ceeAnFaultReq

primitive is used by the AN to notify the SN that a fault with regard to the bearer connection has been detected.

ceeAnFaultAccConf

response to primitive ceeAnFaultReq indicating that the fault indication was received by the SN.

ceeAnFaultRejConf

response to primitive ceeAnFaultReq indicating that the fault indication was not received by the SN.

ceeAddBranchInd

primitive is used to indicate a request from the SN for the allocation of an additional branch to a point-to-multipoint bearer connection.

ceeAddBranchAccRes

response to primitive ceeAddBranchInd indicating that the allocation request has been accepted.

ceeAddBranchRejRes

response to primitive ceeAddBranchInd indicating that the allocation request has been rejected.

ceeUpdateBranchInd

primitive is used to indicate a request from the SN to update the allocation of a branch to a point-to-multipoint bearer connection.

ceeUpdateBranchAccRes

response to primitive ceeUpdateBranchInd indicating that the update request has been successfully completed.

ceeUpdateBranchRejRes

response to primitive ceeUpdateBranchInd indicating that the update request has not been successfully completed.

ceeDropBranchInd

primitive is used to indicate a request from the SN for the de-allocation of a branch from a PM bearer connection.

ceeDropBranchAccRes

response to primitive ceeAddBranchInd indicating that the de-allocation request has been accepted.

ceeDropBranchRejRes

response to primitive ceeAddBranchInd indicating that the de-allocation request has been rejected.

ceeBbccResetInd

primitive is used to indicate a request from the SN for the reset of a bearer connection.

ceeBbccResetAccRes

response to primitive ceeBbccResetInd indicating that the reset request has been accepted.

ceeBbccResetRejRes

response to primitive ceeBbccResetInd indicating that the reset request has been rejected.

meeBbccStartTrafficReq

request to establish the SAAL connection to the peer side and to put the local B-BCC protocol system FSMs in state "in service".

meeBbccStartTrafficConf

response to meeBbccStartTrafficReq confirming that the establishment of the SAAL connection has been completed (success/failed).

meeBbccPresyncInd

primitive is used to indicate a request from the SN to provide the information whether the B-BCC protocol can resume its normal operation with respect to the indicated resource.

meeBbccPresyncAccRes

response to primitive meeBbccPresyncInd indicating that the B-BCC protocol can resume its normal operation with respect to the indicated resource and a B-BCC reset is not necessary.

meeBbccPresyncRejRes

response to primitive meeBbccPresyncInd indicating that a B-BCC reset shall be initiated before the B-BCC protocol can resume its normal operation.

13.4.1.6 Primitive interface between B-BCC protocol system and ATM adaptation layer

This subclause provides the definitions for the AAL primitive interface related to the B-BCC protocol function.

aalBbccEstablishReq

primitive is used to request the establishment of SAAL connection to the peer side.

aalBbccEstablishConf

primitive is used to confirm the successful establishment of the SAAL connection to the peer side.

aalBbccEstablishInd

primitive is used as an indication from the SAAL to the B-BCC protocol system that SAAL connection has been established.

aalBbccReleaseReq

primitive is used to request the release the SAAL connection to the peer side.

aalBbccReleaseConf

primitive is used to confirm the successful release of the SAAL connection to the peer side.

aalBbccReleaseInd

primitive is used to indicate the release of the SAAL connection.

13.4.1.7 Description of VB5 B-BCC messages and parameters

For the definition of VB5 messages and parameters reference is made to clause 14. As far as the SDL system is concerned, only those data are modelled which are needed for the description of the B-BCC protocol functions. The SDL data modelling shall not supersede the messages and parameters as defined in clause 14.

Table 11 lists the B-BCC message parameters which are used within SDL primitives. The primitive parameters can be mapped directly to the information elements transported with the corresponding B-BCC messages.

Table 11: SDL specific B-BCC message parameters

Parameter	SDL usage
Connection Reference Number	ConnRefNo
Branch Identifier	BranchId
Transaction Identifier	TransId
Rejection Cause	RejCause
Protocol Error Cause	ProtErrCause

13.4.2 Block diagrams

Within this subclause the next level of decomposition of the individual block diagrams is specified for both the AN and the SN system diagrams. For each of the processes within an individual block a description of its purpose is given.

13.4.2.1 B-BCC management entities

The processes of the B-BCC management entity at the AN side are shown in figure 15 and further described in table 12.

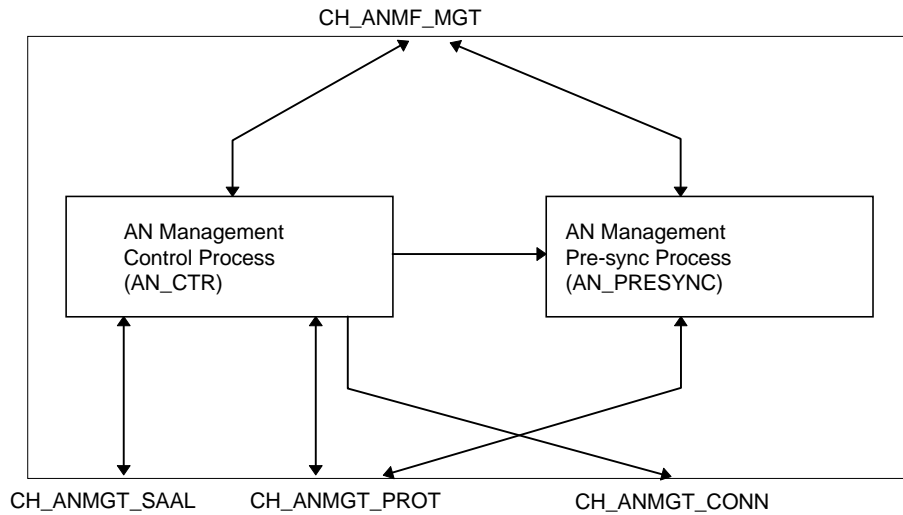

Figure 15: AN B-BCC management block

Table 12: AN B-BCC management processes

AN B-BCC Management Processes (figure 15)	Purpose
AN Management Control Process (AN_CTR)	Co-ordination of AN B-BCC system start-up Supervision of SAAL establishment and release.
AN Management Presync Process (AN_PRESYNC)	Supervision of the pre-synchronization procedure.

The processes of the B-BCC management entity at the SN side are shown in figure 16 and further described in table 13.

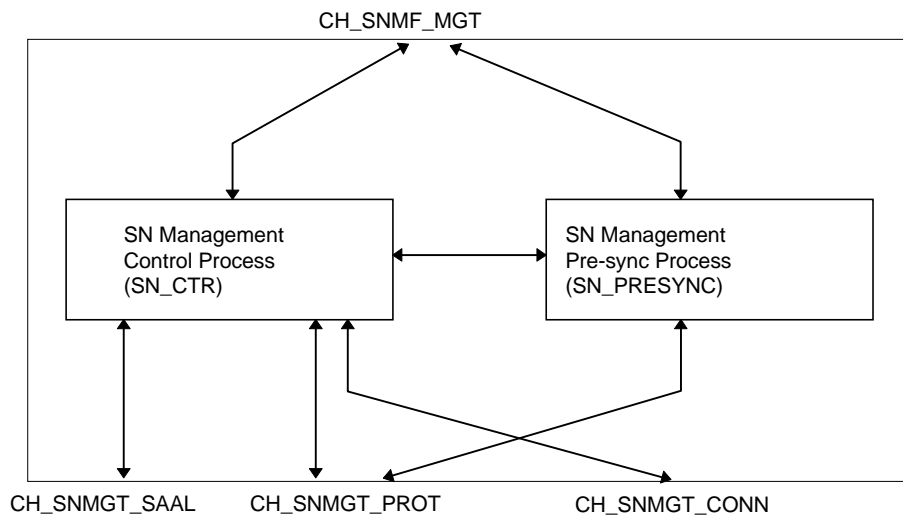

Figure 16: SN B-BCC management block

Table 13: SN B-BCC management processes

SN B-BCC Management Processes (figure 16)	Purpose
SN Management Control Process (SN_CTR)	Co-ordination of SN B-BCC system start-up Supervision of SAAL establishment and release.
SN Management Presync Process (SN_PRESYNC)	Supervision of the pre-synchronization procedure.

13.4.2.2 B-BCC connection management entities

The processes of the B-BCC connection management entity at the AN side are shown in figure 17 and further described in table 14.

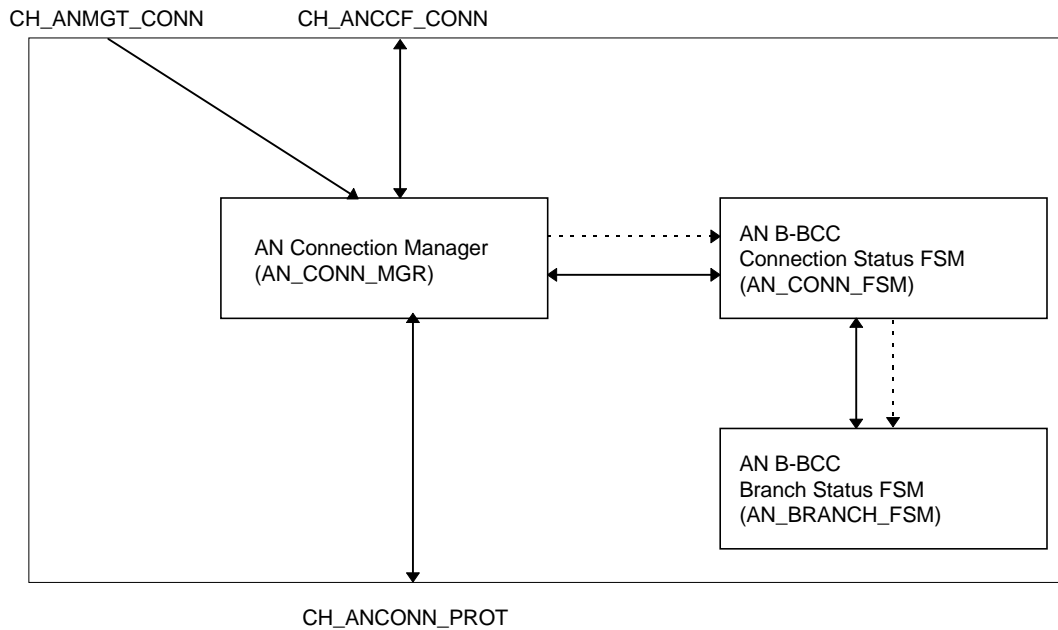

Figure 17: AN connection management block

Table 14: AN B-BCC connection management processes

AN B-BCC Connection Management Processes (figure 17)	Purpose
Connection Manager (AN_CONN_MGR)	Creates and deletes connection FSMs dynamically for handling of connection states. Routing of primitives to/from connection status FSMs.
Connection Status FSM (AN_CONN_FSM)	Handles a single connection. Creates branch status FSMs dynamically for handling of branch connection states in case of PM connection type.
Branch Status FSM (AN_BRANCH_FSM)	Keeps track of the state changes of a single branch connection.

The processes of the B-BCC connection management entity at the SN side are shown in figure 18 and described in table 15.

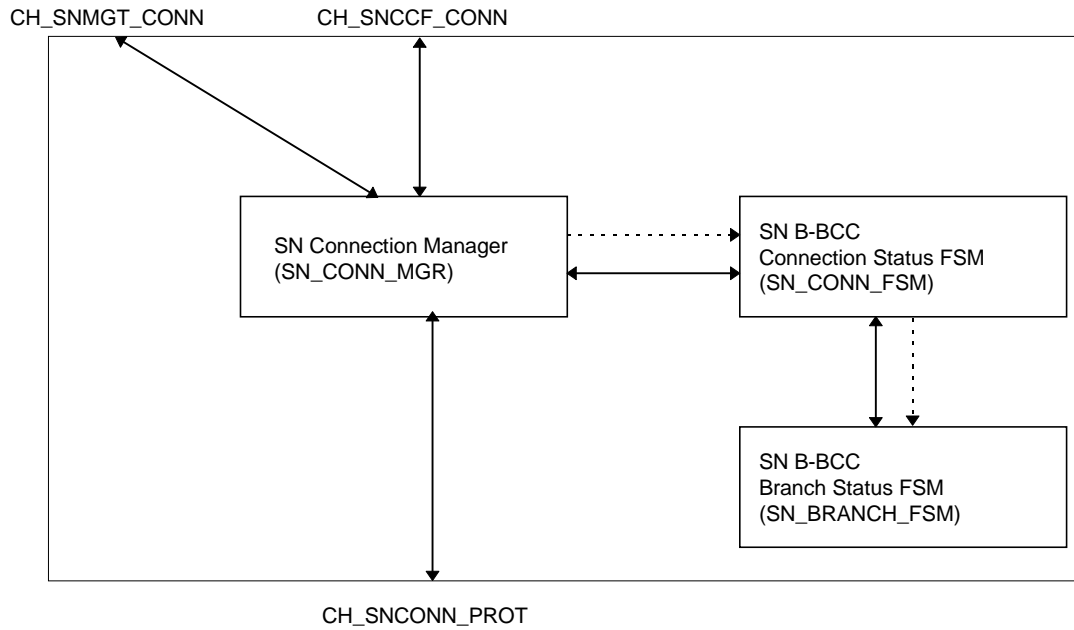

Figure 18: SN connection management block

Table 15: SN B-BCC connection management processes

SN B-BCC Connection Management Processes (figure 18)	Purpose
Connection Manager (SN_CONN_MGR)	Creates and deletes connection FSMs dynamically for handling of connection states.
Connection Status FSM (SN_CONN_FSM)	Handles a single connection. Creates branch FSMs dynamically for handling of branch connection states in case of PM connection type.
Branch Status FSM (SN_BRANCH_FSM)	Keeps track of the state changes of a single branch connection.

13.4.2.3 B-BCC protocol entities

The processes of the B-BCC protocol entity at the AN side are shown in figure 19 and further described in table 16.

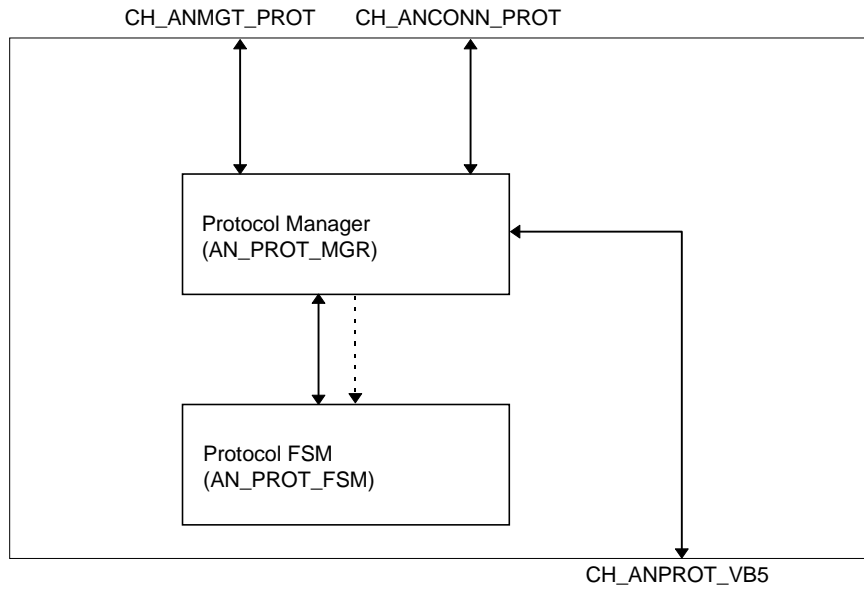

Figure 19: AN B-BCC protocol block

Table 16: AN B-BCC protocol processes

AN B-BCC Protocol Processes (figure 19)	Purpose
Protocol Manager (AN_PROT_MGR)	Creates dynamically AN_PROT_FSM processes for handling of B-BCC protocol transactions. Allocates B-BCC transaction identifiers.
Protocol FSM (AN_PROT_FSM)	Handles a single B-BCC protocol transaction

The processes of the B-BCC protocol entity at the SN side are shown in figure 20 and further described in table 17.

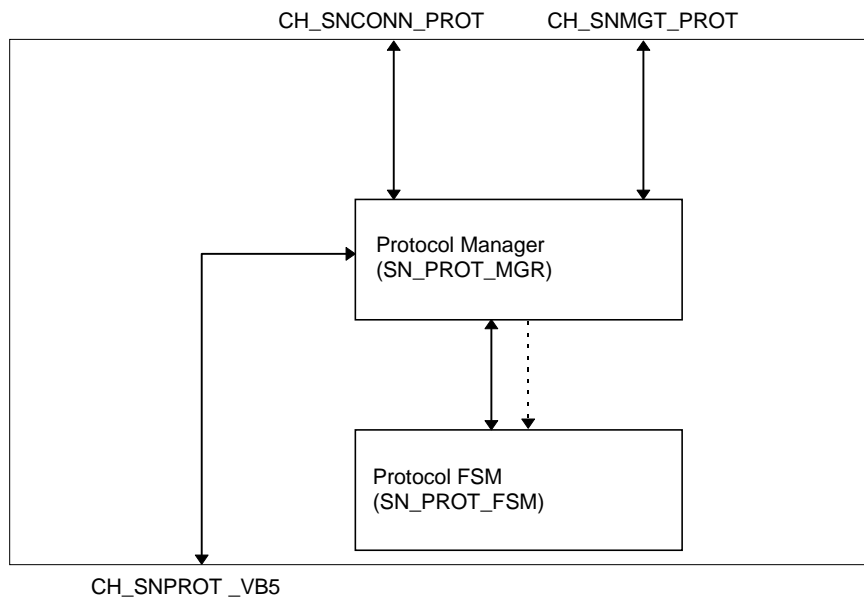

Figure 20: SN B-BCC protocol block

Table 17: SN B-BCC protocol management processes

SN B-BCC Protocol Processes (figure 20)	Purpose
Protocol Manager (SN_PROT_MGR)	Creates dynamically protocol FSMs for handling of B-BCC protocol transactions. Allocates B-BCC transaction identifiers.
Protocol FSM (SN_PROT_FSM)	Handles a single B-BCC protocol transaction.

13.5 VB5.2 connection control functions

13.5.1 General

Figure 21 shows the basic structure of the B-BCC application functions which use the communication procedures provided by the B-BCC system and how these functions are embedded in the SN and AN environment.

This clause describes the VB5.2 connection control functions. The VB5.2 management functions are described in ITU-T Recommendation Q.832.2 [48].

The VB5.2 connection control is triggered by external events e.g. DSS2 or B-ISUP signalling. The required interworking functions between the user and network signalling with the B-BCC shall be provided in the SN. Annex B illustrates the scenario where interworking with DSS2 and B-ISUP is done and gives an introduction about the interaction of the three protocols.

This subclause describes the VB5.2 specific aspects of the connection control application in the SN and AN and refers to the following network element internal interfaces:

- The interface between the connection control application functions and the B-BCC system. This interface is referred to as the cee primitive interface, which has been introduced in subclause 13.1 and further detailed in subclause 13.4.
- The internal interface within AN and SN application. This interface provides for the required co-ordination between the application functions (such as the call control function of the SN and the resource management function of the AN) and the relevant VB5.2 application functions. This split within the application functions has only been introduced to allow a complete description of the VB5.2 specific aspects of the procedures. Therefore this interface is not specified in detail.

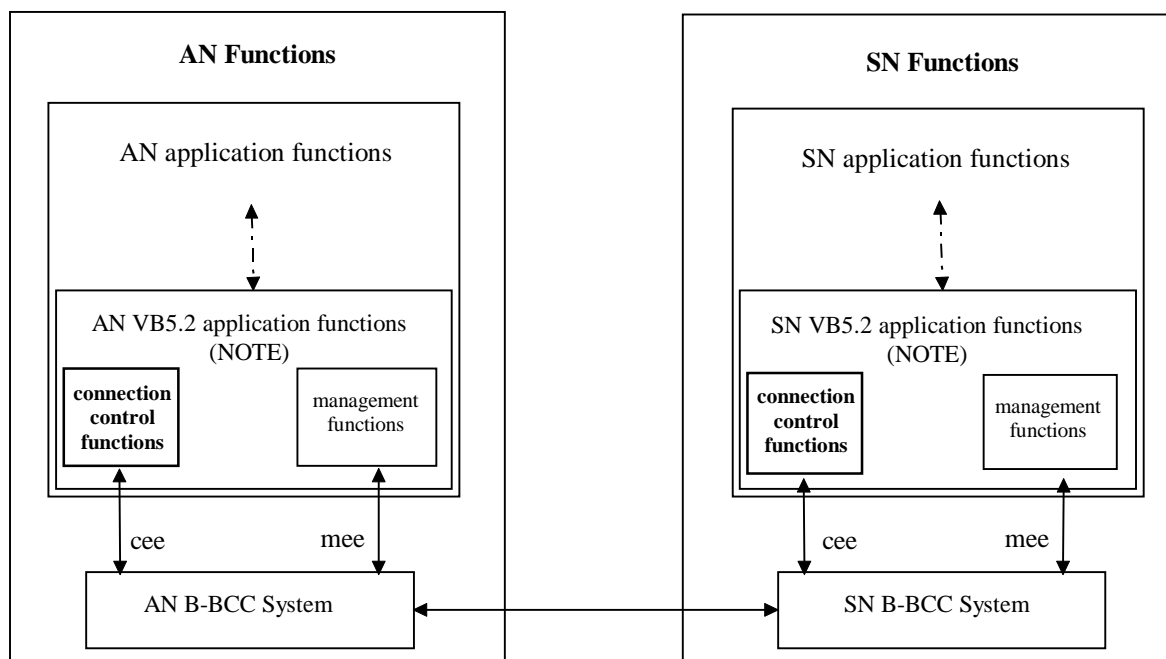

NOTE: Management functions which use the communication capabilities provided by the RTMC system are not shown in this diagram.

Figure 21: Environment of the VB5.2 B-BCC application functions

13.5.2 Interworking with user signalling

In an access arrangement with VB5.2 reference point, the B-BCC enables the establishment, modification and release of VCCs in the AN under control of the SN. Therefore, concerning the bearer related functions, the AN can be considered as a VC switch being remotely controlled.

The SN provides a mapping from the bearer related information transferred within the user-to-network signalling messages to the information transferred within the B-BCC protocol.

The B-BCC protocol provides the means to convey bearer relevant information between the SN and the AN. This allows the AN to participate in the bearer related procedures such as negotiation of traffic parameters, modification of connection characteristics, ABR parameter set up, transit delay accumulation.

13.5.2.1 Interworking with DSS2 based signalling systems

The user-to-network signalling system specified by the ITU-T is the DSS2. In order to simplify both the interworking with DSS2 and the definition of future B-BCC enhancements based on potential DSS2 extensions, the contents of many of the information elements used by the B-BCC are copies of those used within DSS2 (see subclause 14.3.7).

The following list identifies the bearer relevant information that shall be conveyed to the AN if provided in the relevant DSS2 messages:

- ATM traffic descriptor;
- broadband bearer capability;
- end-to-end transit delay;
- OAM traffic descriptor;
- quality of service;

- ABR set-up parameters;
- CDVT;
- minimum acceptable ATM traffic descriptor;
- alternative ATM traffic descriptor;
- connection identifier.

NOTE: In the B-BCC protocol, the contents of the connection identifier become part of the user port connection identifier.

The use of these information elements is described in DSS2 and only referred to in the following subclause if AN specific actions are required.

See annex B for illustration as to how the DSS2 and the B-BCC can interwork.

13.5.2.2 Support of user-to-network signalling systems other than DSS2

The support of ATM-Forum 4.0 user-to-network signalling system is described in annex B.

The support of other user-to-network signalling systems is for further study.

13.5.3 Allocation of VPCI/VCI and bandwidth

The SN as well as the AN are responsible for their network element internal resource management. The VPCI/VCI selection procedure defined in this subclause allows that either the AN or the SN assign the VPCI/VCI values and allocate the associated resources such as bandwidth and cell buffers. It is up to the SN operator to use this procedure to optimize the overall resource utilization.

13.5.3.1 VPCI/VCI selection procedure for the service port

The VPCI/VCI selection for the service port is controlled by the SN VB5.2 connection control function. The VPCI/VCI selection procedure for the service port is used within the allocation procedure (i.e., VPCI/VCI selection is part of the connection establishment).

13.5.3.1.1 VPCI/VCI selection procedure start at the SN

When establishing a bearer connection the SN connection control function operates in one of the two modes described below:

- a) Exclusive mode: VPCI/VCI selection by the SN.

The SN connection control shall perform the following actions:

- A VPC at the SNI which can provide the requested bandwidth, ATM transfer capability, QoS and traffic parameters is selected.
- Resources such as VCI value, bandwidth, cell buffers are assigned to the connection. The SN internal book keeping with respect to bandwidth, VCI values, etc. of the selected VPC is updated.
- A service port connection identifier containing the selected VPCI/VCI combination (indicated as being exclusive) is provided.

- b) Non-exclusive mode: VPCI/VCI recommendation by the SN, final selection by the AN.

The SN connection control function shall perform the following actions:

- A preferred VPC at the SNI which can provide the requested bandwidth ATM transfer capability, QoS and traffic parameters is selected.

- Resources such as VCI value, bandwidth, cell buffers are reserved for the connection. The SN internal book keeping with respect to bandwidth, VCI values, etc. of the selected VPC is updated.
- A service port connection identifier containing the selected VPCI/VCI combination (indicated as being preferred) is provided.
- A list of alternative VPCs where each of the VPCs can support the requested ATM transfer capability and QoS is provided.

NOTE: If the SN is able to recommend only one VPCI, the list of alternative VPCs will be absent.

For a particular VB5.2 reference point, the SN may operate in either the exclusive mode or in the non-exclusive mode. In order to prevent VCI collisions, the SN shall not change the mode on a per connection basis.

13.5.3.1.2 VPCI/VCI selection procedure at the AN

The AN connection control function analyses the service port connection identifier and takes the following actions.

a) Receipt of an VPCI/VCI combination.

The AN connection control function shall perform the following actions:

- If the requested resources are available in the AN, the AN internal book keeping with respect to bandwidth and VCI values of the requested VPCI is updated. Resources such as VCI value, bandwidth, cell buffers are assigned to the connection.

If the requested resources are not available in the AN, the request is rejected.

b) Receipt of a preferred VPCI/VCI combination and a list of alternative VPCs.

The AN connection control function shall perform the following actions:

1) If the preferred VPCI/VCI combination can be supported:

- The AN internal book keeping with respect to bandwidth and VCI values of the preferred VPCI is updated. Resources such as VCI value, bandwidth, cell buffers are assigned to the connection.

2) If the preferred VPCI/VCI cannot be supported but an alternative combination can be accepted:

- If the preferred VPCI can be supported but the preferred VCI cannot be supported, an available alternative VCI value is selected. The AN internal book keeping with respect to bandwidth and VCI values of the preferred VPC is updated. Resources such as VCI value, bandwidth, cell buffers are assigned to the connection.
- If the preferred VPCI cannot be supported, a VPC from the list of alternative VPCs is selected which can provide the requested bandwidth, ATM transfer capability, QoS and traffic parameters. In addition, an available VCI within that VPC is selected. The AN internal book keeping with respect to bandwidth and VCI values of the selected VPC is updated. Resources such as VCI value, bandwidth, cell buffers are assigned to the connection. Selection procedure at the AN.

A service port connection identifier containing the selected VPCI/VCI shall be returned by AN connection control function in the response to the SN.

3) If neither the preferred nor an alternative VPCI/VCI combination can be supported, the request is rejected.

13.5.3.1.3 Selection procedure termination at the SN

The SN connection control function analyses the response from the AN and takes the following actions.

a) When the SN has operated in the exclusive mode and receives a positive response from the AN, the SN connection control function shall perform the following actions:

- Proceed with the connection establishment.

- b) When the SN has operated in the non-exclusive mode and receives a positive response from the AN, the SN connection control function shall perform the following actions:
- 1) If the AN has accepted the preferred VPCI/VCI combination:
 - Proceed with connection establishment.
 - 2) If the AN has selected an alternative VPCI/VCI combination which can be supported by the SN:
 - The reservations made according to the preferred VPCI/VCI combination are cancelled.
 - The SN internal book keeping with respect to bandwidth and VCI values of the selected VPC is updated. Resources such as VCI value, bandwidth, cell buffers are assigned to the connection.
 - Proceed with the connection establishment.
 - 3) If the AN has selected an alternative VPCI/VCI combination which cannot be supported by the SN:
 - The reservations made according to the preferred VPCI/VCI combination are cancelled.
 - The bearer connection in the AN and the connection towards the user is released.
- c) When the SN receives a negative response (i.e. reject) from the AN, the SN connection control function shall perform the following actions:
- The connection is released towards the user.
 - The resources assigned or reserved for the connection are freed up.

13.5.3.2 VPCI/VCI selection procedure for the user port

The VPCI/VCI for the user port is selected by either the network (i.e., SN or AN) or the user.

The functional split within the SN application functions with respect to the user port VPCI/VCI is different from the functional split with respect to the service port VPCI/VCI:

- For the service port, the VPCI/VCI selection is controlled by the VB5.2 connection control function itself.
- For the user port, the VPCI/VCI selection is controlled by the user-to-network signalling application within the SN. The SN VB5.2 connection control function receives the LUP identifier and the VPCI/VCI combination from the call control co-ordination function. The information is used to set up the user port connection identifier information element which is passed to the SN B-BCC system and conveyed to the AN.

Apart from the differences with respect to the controlling entity, the VPCI/VCI selection procedure for the user port is identical to the VPCI/VCI selection procedure for the service port as described in subclause 13.5.3.1. Although the specification of the VPCI/VCI selection procedure in subclause 13.5.3.1 specifically refers to the service port, it applies equally to the user port.

In addition, the following rules and constraints apply:

- a) When the VPCI/VCI is selected by the network, the VPCI/VCI selection procedure for the user port is used within:
- either the allocation procedure (if VPCI/VCI selection is performed as part of the connection establishment procedure);
 - or the add branch procedure (if VPCI/VCI selection is performed as part of the branch establishment procedure).

The SN can operate in either the exclusive or the non-exclusive mode.

b) When the VPCI/VCI is selected by the user and the SN knows the VPCI/VCI before the B-BCC procedure for connection establishment or branch establishment is initiated (e.g. case of originating call as illustrated in annex B, figure B.2), the VPCI/VCI selection procedure for the user port is also used within:

- either the allocation procedure (if VPCI/VCI selection is performed as part of the connection establishment procedure);
- or the add branch procedure (if VPCI/VCI selection is performed as part of the branch establishment procedure).

The SN can operate in the exclusive mode only, due to the fact that the VPCI/VCI combination has been selected by the user.

c) When the VPCI/VCI is selected by the user and the SN does not know the VPCI/VCI before the B-BCC procedure for connection establishment or branch establishment is initiated (e.g. case of terminating call as illustrated in annex B, figure B.3), the VPCI/VCI selection procedure for the user port is used within:

- either the allocation complete procedure (if VPCI/VCI selection is performed as part of the connection establishment procedure);
- or the update branch procedure (if VPCI/VCI selection is performed as part of the branch establishment procedure).

The SN can operate in the exclusive mode only, due to the fact that the VPCI/VCI combination has been selected by the user.

13.5.4 Connection establishment and parameter negotiation

The procedure described in this subclause applies to the establishment of a point-to-point connection and to the establishment of the root including the first branch of a point-to-multipoint connection in the AN.

NOTE: The necessary actions to control services which are susceptible to clipping can be performed within the SN as illustrated in annex C Connection establishment in the AN is done in the same way for connections which are susceptible to clipping and those that are not.

13.5.4.1 Connection establishment start in the SN

Trigger: A request from the call control co-ordination function (see annex B) to establish a bearer connection in the AN is received.

Actions: The SN connection control function shall perform the following actions:

- The connection reference number is assigned.
- If a point-to-multipoint connection shall be established, a branch identifier (for the first branch of the point-to-multipoint connection) is assigned and the corresponding information element is set up. The instruction indicator shall be coded to "discard information element and proceed".
- The bearer related information elements received from the call control co-ordination function are used to set up the ceeAllocReq primitive.

If the VPCI/VCI for the user port is not yet known by the SN (i.e. the user port VPCI/VCI will be selected by the user at a later point in time within the connection establishment phase), then the user port connection identifier information element contains a LUP identifier without VPCI/VCI combination.

- Selection of VPCI/VCI for the service port is initiated (see subclause 13.5.3.1.1).
- Concerning the timing of through connecting, the behaviour of the SN shall exactly follow the behaviour for directly connected subscribers.
- A ceeAllocReq primitive shall be passed to the SN B-BCC system.

13.5.4.2 Connection establishment start in the AN

Trigger: A `ceeAllocInd` primitive is received.

The AN is informed by the SN whether it is the AN at the originating interface or at the destination interface. That allows the AN to identify the forward and backward direction of the traffic descriptors and to synchronize the activation of UPC and NPC functions with the progress of the connection set up.

NOTE: A point-to-multipoint connection in the AN can only be established if the AN is at the terminating side of the connection.

Actions: The AN connection control function shall perform the following actions:

- Selection of VPCI/VCI is performed for the service port (see subclause 13.5.3.1.2) and, if applicable at this point in time, for the user port (see subclause 13.5.3.2).
- If applicable, negotiation of parameters is performed (see subclause 13.5.4.3).
- If applicable, ABR parameters are set up.
- Status with respect to automatic congestion control is checked.

Actions performed at the originating interface only:

- Through connect in backward direction.
- Set up of NPC function (optional) in forward direction.

Actions performed at the destination interface only:

- If the selection of VPCI/VCI for the user port has been performed, through connect in forward direction.
- Set up of NPC function (optional) in forward direction.

Response: If the connection can be established, a `ceeAllocAccRes` primitive shall be passed to the AN B-BCC system.

If the connection cannot be established, a `ceeAllocRejRes` primitive shall be passed to the AN B-BCC system with the appropriate reject cause (see table 57).

13.5.4.3 Parameter negotiation in the AN

This procedure is based on the principles of parameter negotiation described in Recommendation Q.2962. The common use of information elements in DSS2 and B-BCC information elements is shown in annex B. The parameter negotiation procedure in the AN can be applied when the `ceeAllocInd` primitive contains either an alternative ATM traffic descriptor or the minimum ATM traffic descriptor. Consequently two different procedures are supported by the AN B-BCC connection control function.

a) Alternative traffic parameter negotiation:

If the AN B-BCC connection control application is not able to support the ATM traffic parameters given in the ATM traffic descriptor information element but able to provide the ATM traffic descriptor given in the Alternative ATM traffic descriptor information element, the connection establishment request is progressed by using the contents of the Alternative ATM traffic descriptor information element as the new ATM traffic descriptor. Only this new ATM traffic descriptor is returned via the `ceeAllocAccRes` primitive.

If neither the ATM traffic descriptor given in the ATM traffic descriptor information element nor the ATM traffic descriptor indicated in the Alternative ATM traffic descriptor information element can be supported, then the AN B-BCC connection control application responds with an `ceeAllocRejRes` primitive with the appropriate reject cause (see table 57).

If the Alternative ATM traffic descriptor information element is included in the `ceeAllocReqInd` primitive and the AN is able to provide the traffic parameter values specified in the ATM traffic descriptor information element and the AN is able to provide the traffic parameter values specified in the Alternative ATM traffic descriptor information element, the AN B-BCC connection control application shall progress the connection establishment request and respond with a `ceeAllocAccRes` with both of the above information elements included unchanged.

When the Alternative ATM traffic descriptor information element is included in the `ceeAllocReqInd` primitive and the AN is able to provide the traffic parameter values specified in the ATM traffic descriptor information element but is not able to provide the traffic parameter values specified in the Alternative ATM traffic descriptor information element, then the AN connection control application shall progress the connection establishment but only the ATM traffic descriptor in the `ceeAllocAccRes` primitive is returned. This indicates the SN that the Alternative ATM traffic descriptor can not be passed along the network.

b) Minimum acceptable ATM traffic parameter negotiation:

If the AN B-BCC connection control application is not able to support the ATM traffic parameters given in the ATM traffic descriptor information element but able to provide at least their corresponding cell rates in the Minimum acceptable ATM traffic descriptor information element, the AN shall progress the connection establishment request after adjusting the cell rates values in the ATM traffic descriptor information element. The adjusted parameter values shall support at least the corresponding minimum acceptable values. If some of the parameters in the Minimum acceptable ATM traffic descriptor information element are still less than the corresponding parameters in the modified ATM traffic descriptor information element, then the AN B-BCC connection control application shall return with the `ceeAllocAccRes` primitive the Minimum acceptable ATM traffic descriptor information element containing all such parameters, and in addition the modified ATM traffic descriptor information element. Otherwise, the modified ATM traffic descriptor information element only is returned.

If the AN is not able to provide at least the cell rates indicated in the Minimum acceptable ATM traffic descriptor information element, the AN B-BCC connection control application shall respond with an `ceeAllocRejRes` primitive with the appropriate reject cause (see table 57).

If the Minimum acceptable ATM traffic descriptor information element is included in the `ceeAllocReq` primitive and the AN is able to provide the traffic parameter values specified in the ATM traffic descriptor information element, the AN B-BCC connection control application shall progress the connection establishment and return a `ceeAllocAccRes` primitive with both of the above information elements included.

13.5.4.4 Connection establishment continuation in the SN

a) Receiving the response from the SN B-BCC system

positive response:

Trigger: A `ceeAllocAccConf` primitive is received.

Action: The connection establishment is proceeded. The information elements received from the AN shall be checked and then forwarded to the call control co-ordination function where they are used for further proceeding of the connection set up (see annex B). If the AN has selected an alternative VPCI/VCI combination can not be supported by the SN, then the connection set up failed (see subclause 13.5.3.1.3).

negative response:

Trigger: A `ceeAllocRejConf` primitive is received by the SN B-BCC connection control application.

Action: reject cause: transmission error.

- The call control co-ordination function is informed that the connection set up was not successful.

reject cause: message incompatible with the connection state:

- The call control co-ordination function is informed that the connection set up was not successful. The connection reference in the AN (hanging connection) shall be deallocated by sending a `ceeDeallocReq` primitive to the B-BCC system.

reject cause: service port connection identifier already in use; or
user port connection identifier already in use.

- The call control co-ordination function is informed that the connection set up was not successful. A `ceeBccResetReq` primitive is passed to the SN B-BCC system to reset the indicated service port or user port resource to the idle state.

all other reject causes:

- The call control co-ordination function is informed that the connection set up was not successful.

b) Receiving the response from the call terminating entity.

Trigger: The SN call co-ordination function is informed that the VCC is connected at the destination interface.

Action: The AN is informed to allow a possible update and final allocation of bearer connection parameters. A `ceeAllocCompReq` primitive shall be passed to the SN B-BCC system.

Trigger: The SN connection control function is informed that the VCC set up failed.

Action: The connection in the AN is deallocated. A `ceeDeallocReq` primitive shall be passed to the SN B-BCC system.

13.5.4.5 Connection establishment termination in the AN

Trigger: A `ceeAllocCompInd` primitive is received.

Actions: The AN connection control function shall perform the following actions:

- If the `ceeAllocCompInd` primitive contains ATM traffic parameters which changed due to negotiation or ABR parameter set-up handling, the allocation of resources in the AN shall be updated accordingly.

Actions performed at the originating interface only:

- Through connect in forward direction.
- Set-up of UPC in forward direction.

Actions performed at the destination interface only:

- Through connect in backward direction.
- Set-up of UPC in backward direction.
- Through connect in forward direction (if not yet done).

Response: If the connection establishment can be completed, a `ceeAllocCompAccRes` primitive shall be passed to the AN B-BCC system.

If the connection establishment cannot be completed:

- the connection reference number is released;
- the reserved resources are released;
- a `ceeAllocCompRejRes` primitive with the appropriate reject cause (see table 57) shall be passed to the AN B-BCC system.

13.5.4.6 Connection establishment termination in the SN

a) positive response from the SN B-BCC system:

Trigger: A `ceeAllocCompAccConf` primitive is received.

Actions: The access network part of the bearer connection has been successfully established. The call control co-ordination function is informed to proceed the connection set up.

b) negative response from the SN B-BCC system:

Trigger: A `ceeAllocCompRejConf` primitive is received.

Actions: reject cause: transmission error:

- The call control co-ordination function is informed to release the connection. In addition a `ceeDeallocReq` primitive is passed to SN B-BCC system.

all other reject causes:

- The call control co-ordination function is informed to release the connection.

13.5.5 Release of connections

13.5.5.1 Connection release start in the SN

Trigger: A request from the call control co-ordination function to release a bearer connection in the AN is received.

Actions: A `ceeDeallocReq` primitive shall be passed to the SN B-BCC system.

13.5.5.2 Connection release in the AN

Trigger: A `ceeDeallocInd` primitive is received.

Actions: The AN connection control function shall perform the following actions:

- The connectivity between user port and service port is released.
- The allocated resources are made available for new traffic.
- The signalling association given by the connection reference number is terminated.
- The VCI values are made available for use by later connections.

Response: A `ceeDeallocAccRes` primitive shall be passed to the AN B-BCC system.

13.5.5.3 Connection release termination in the SN

a) positive response from the SN B-BCC system:

Trigger: A `ceeDeallocAccConf` primitive is received.

Actions: The SN connection control function shall perform the following actions:

- The associated service port VPCI/VCI shall be made available for new traffic.
- The call control co-ordination function is informed that the user port VCI has been released in the AN.
- The allocated resources are made available for new traffic.
- The signalling association for the connection is terminated.

b) negative response from the SN B-BCC system:

Trigger: A `ceeDeallocRejConf` primitive is received.

Actions: reject cause: transmission error:

- The connection control function continues to try to free up the resources in the AN. The resources in the SN are not released. It is up to the SN maintenance to decide what to do if the problem continues to exist.

Other reject causes do not apply.

13.5.5.4 Use of en bloc deallocation

Besides the release of a single connection it is also possible that the SN connection control function applies en bloc deallocation mechanism. It is applied e.g. during system restart or DSS2 restart. In this case, the `ceeDeallocReq` primitive generated by the SN connection control function includes a list of connection reference numbers instead of a single connection reference number. The list can contain more elements than can be carried by one message. It is the responsibility of the B-BCC system to perform the necessary segmentation.

After the connection release procedure has been completed, the SN connection control function receives a single `ceeDeallocConf` primitive.

The AN connection control function is triggered by `ceeDeallocInd` primitives, each containing a list of connection reference numbers. For each connection reference number the connection release procedure is performed.

The AN connection control function passes one `ceeDeallocAccRes` primitive per `ceeDeallocInd` primitive to the AN B-BCC system.

13.5.6 Modification of traffic parameters

During the data transfer phase it is possible to modify ATM traffic parameters in the AN under the control of the SN. The procedure is based on Recommendation Q2963.1-3 and the same principles apply. For details concerning the DSS2/B-BCC interworking see annex B. Parameter negotiation during the modification procedure by using the alternative ATM traffic descriptor or the minimum acceptable ATM traffic descriptor is supported.

13.5.6.1 Modification start in the SN

Trigger: A request from the call control co-ordination function to modify the traffic characteristics of a bearer connection in the AN is received.

Actions: A `ceeModifyReq` primitive shall be passed to the SN B-BCC system.

13.5.6.2 Modification start in the AN

Trigger: A `ceeModifyInd` primitive is received.

Actions: The AN connection control function shall perform the following actions:

- in case of increase of ATM traffic parameters, reserve the corresponding resources;
- in case of decrease of ATM traffic parameters, keep the original reservation of resources.

In case of modification with negotiation the `meeModifyReq` primitive may include an Alternative ATM traffic descriptor or a Minimum acceptable ATM traffic descriptor in addition to the ATM traffic descriptor. The negotiation during modification is done as described in subclause 13.5.4.3.

Actions performed at the originating interface only:

- in case of decrease of forward ATM traffic parameters, change the UPC in forward direction;
- in case of increase of backward ATM traffic parameters, change the NPC (if applicable) in backward direction.

Actions performed at the destination interface only:

- in case of decrease of forward ATM traffic parameters, change the NPC (if applicable) in forward direction.

Response: If the AN connection control function is able to support the modification or the modification with negotiation, a `ceeModifyAccRes` shall be passed to the AN B-BCC system.

If the AN connection control function can support neither the modification as requested in the ATM traffic descriptor nor the ATM traffic parameter values offered for negotiation, a `ceeModifyRejRes` with appropriate reject cause (see table 57) shall be passed to the AN B-BCC system.

13.5.6.3 Progressing modification in the SN

a) Receiving the response from the SN B-BCC system

positive response:

Trigger: A `meeModifyAccConf` is received.

Action: The call control co-ordination is informed to proceed with the modification.

negative response:

Trigger: A `meeModifyRejConf` is received.

Action: reject cause: transmission error:

- Call control co-ordination is informed to release the connection and a `ceeDeallocReq` primitive shall be passed to SN B-BCC system.

all other reject causes:

- The call control co-ordination is informed to reject the modification towards the connection owner.

b) Receiving the response from the call terminating entity

Trigger: A request from the call control co-ordination function to inform the AN that the modification was successful is received.

Action: A `ceeModifyCompReq` primitive shall be passed to the SN B-BCC system. In case that negotiation of ATM traffic was applied, the final ATM traffic descriptor shall be included.

Trigger: Request from the call control co-ordination functions to abort the modification.

Action: A `ceeModifyAbortReq` primitive shall be passed to the SN B-BCC system.

13.5.6.4 Modify completion in the AN

Trigger: A `ceeModifyCompInd` primitive is received.

Actions: The AN connection control function shall perform the following actions:

- allocate the corresponding resources.

Actions performed at the originating interface only:

- in case of decrease of backward ATM traffic parameters, change the NPC (if applicable) in backward direction;
- in case of increase of forward ATM traffic parameters, change the UPC in forward direction.

Actions performed at the destination interface only:

- change the UPC in backward direction;
- in case of increase of forward ATM traffic parameters, change the NPC (if applicable) in forward direction.

If the `ceeModifyCompInd` primitive contains an ATM traffic descriptor, the allocation of the corresponding resources and the adjustment of UPC and NPC shall be performed according to this (updated) ATM traffic descriptor.

Response: If the modification of the traffic parameters has been successfully completed in the AN, a `ceeModifyCompAccRes` primitive shall be passed to the B-BCC system.

If the modification of the traffic parameters can not be performed, a `ceeModifyCompRejRes` primitive with appropriate reject cause (see table 57) shall be passed to the AN B-BCC system.

Trigger: A `ceeModifyAbortInd` primitive is received.

Action: The original traffic parameters as they were valid before modification started are used again.

Response: If the modification is aborted in the AN, a `ceeModifyAbortAccRes` primitive shall be passed to the AN B-BCC system.

If, due to an error condition in the AN, the installation of the old traffic parameters can not be performed, a `ceeModifyAbortRejRes` primitive containing reject cause of "AN fault" (see table 57) shall be passed to the AN B-BCC system.

13.5.6.5 Modify terminated at the SN

a) positive response from the SN B-BCC system:

Trigger: A `ceeModifyCompAccConf` primitive is received.

Action: The SN connection control function terminates the modification successfully and informs the call control co-ordination function which shall proceed the modification towards the connection owner.

Trigger: A `ceeModifyAbortAccConf` primitive is received.

Action: The SN connection control function informs the call control co-ordination function that the modification was aborted as requested.

b) negative response from the SN B-BCC system:

Trigger: A `ceeModifyCompRejConf` primitive or a `ceeModifyAbortRejConf` is received.

Action: The SN connection control function informs the call control co-ordination function to release the connection. In addition, the SN shall release of the bearer connection in the AN is started.

13.5.7 Establishment of branches of point-to-multipoint connections

The procedures to support point-to-multipoint connections in VB5.2 access arrangements are based on the procedures described in ITU-T Recommendation Q.2971 (see annex B). A point-to-multipoint VCC is a collection of associated ATM VC links that connect two or more endpoints. Leaves can be added and removed during the lifetime of the connection. These leaves are added at the most optimal point within the network which could be the originating SN, transit SN, destination SN, destination AN or a destination network termination type 2 (NT 2). Leaves in the AN are called branches.

A point-to-multipoint connection in the AN (i.e. with branching point inside the AN) is established by first requesting the establishment of a connection between the service port and one user port, indicating point-to-multipoint in the broadband bearer capability information element. For this procedure, the connection establishment procedure described in subclause 13.5.4 is applied.

The addition and deletion of additional branches in the AN is done by using the B-BCC procedure described below.

A point-to-multipoint connection in the AN can only be established if the AN is at the destination interface (i.e. at the terminating side of the connection).

13.5.7.1 Branch establishment start in the SN

Trigger: Request to establish an additional branch to an existing point-to-multipoint connection in the AN. This applies to situations where already one or more user ports at the AN are connected to the point-to-multipoint connection.

Actions performed by the SN connection control function:

- A branch identifier is assigned.
- A `ceeAddBranchReq` primitive shall be passed to the SN B-BCC system.

If the VPCI/VCI for the user port is not yet known by the SN (i.e. the user port VPCI/VCI will be selected by the user at a later point in time within the branch establishment phase), then the user port connection identifier information element contains a LUP identifier without VPCI/VCI combination.

13.5.7.2 Branch establishment start in the AN

NOTE: This procedure applies only if the AN is at the destination interface.

Trigger: A `ceeAddBranchInd` primitive is received.

The actions are related to the user port only, because the service port related resources have already been allocated by the connection establishment procedure. The actions in the AN depend on the availability of VPCI/VCI in the user port connection identifier.

a) The user port VPCI/VCI is contained in the `ceeAddBranchInd` primitive.

Actions: The AN connection control function shall perform the following actions:

- check for point-to-multipoint resources.

Selection of VPCI/VCI for the user port is performed as described in subclause 13.5.3.2:

- connect user port to the root connection at the service port;
- set up of UPC in backward direction to prevent backward user traffic.

Response: If the AN connection control function is able to establish the branch, a `ceeAddBranchAccRes` shall be passed to the AN B-BCC system. Then from the AN point of view the branch establishment procedure is completed.

If the AN connection control function is not able to establish the branch, a `ceeAddBranchRejRes` primitive with appropriate reject cause (see table 57) shall be passed to the AN B-BCC system.

b) The user port VPCI/VCI is not contained in the `ceeAddBranchInd` primitive.

Actions: In this case the AN can not complete the branch establishment procedure. The AN connection control function shall perform the following actions:

- check for point-to-multipoint resources.

Response: If the AN connection control function is able to handle an additional branch in the AN, a `ceeAddBranchAccRes` primitive shall be passed to the AN B-BCC system. The AN connection control function has to wait for the `ceeUpdateBranchInd` to complete the branch establishment procedure.

If the AN connection control function is not able to handle an additional branch, a `ceeAddBranchRejRes` primitive with appropriate reject cause (see table 57) shall be passed to the AN B-BCC system.

13.5.7.3 Branch establishment continuation/completion in the SN

a) Receiving the response from the SN B-BCC system

positive response:

Trigger: A meeAddBranchAccConf primitive is received.

Action: The call control co-ordination function is informed, which subsequently will continue with setting up the leaf.

negative response:

Trigger: A meeAddBranchRejConf primitive is received.

Action: reject cause: transmission error:

- The call control co-ordination function is informed that the attempt to add a party in the AN has failed.

reject cause: incompatible with connection state:

- The SN connection control function informs the call control co-ordination function to release the connection. In addition, the release of the bearer connection in the AN is started.

reject cause: incompatible with branch state:

- The call control co-ordination function is informed that the attempt to add a party in the AN has failed. A ceeDropBranchReq primitive shall be passed to the SN B-BCC system.

all other reject causes:

- The call control co-ordination function is informed that the attempt to add a party in the AN has failed.

b) Receiving the response from the call terminating entity

Trigger: An indication that the VCL to the party has been connected is received from the call control co-ordination function.

Actions: The SN connection control function has to decide whether the AN needs to be informed.

- If the branch is already established in the AN, no action is required.
- If the branch is not yet completely established in the AN because the VPCI/VCI combination was selected by the user, the update branch procedure shall be initiated. An ceeUpdateBranchReq primitive including the user port connection identifier shall be passed to the SN B-BCC system.

Trigger: The SN connection control function is informed that the set up of the branch failed.

Action: The branch in the AN is released. A ceeDropBranchReq primitive shall be passed to the SN B-BCC system.

13.5.7.4 Branch establishment termination in the AN

Trigger: A ceeUpdateBranchInd primitive is received. This applies to situations where the branch establishment procedure in the AN is waiting for the user port VPCI/VCI.

Action: The AN connection control function shall perform the following actions:

- Selection of VPCI/VCI for the user port is performed as described in subclause 13.5.3.2.
- Connect the user port to the root connection at the service port.
- Set up of UPC in backward direction to prevent backward user traffic.

Response: If the AN connection control is able to establish the branch, a ceeUpdateBranchAccRes primitive shall be passed to the AN B-BCC system.

If the AN connection control function is not able to establish the branch, the branch identifier is released and a ceeUpdateBranchRejRes primitive with an appropriate reject cause (see table 57) shall be passed to the AN B-BCC system.

13.5.7.5 Branch establishment termination in the SN

a) positive response from the SN B-BCC system:

Trigger: A `ceeUpdateBranchAccConf` primitive is received.

Action: The call control co-ordination function is informed that the branch has been successfully set up in the AN.

b) negative response from the SN B-BCC system:

Trigger: A `ceeUpdateBranchRejConf` primitive is received.

Action: reject cause: transmission error:

- The call control co-ordination function is informed that the attempt to add a party in the AN has failed and the branch related resources are released. In addition, a `ceeDropBranchReq` primitive (or a `ceeDeallocReq` primitive) shall be passed to the SN B-BCC system.

all other reject causes:

- The call control co-ordination function is informed that the attempt to add a party in the AN has failed and the branch related resources are released.

13.5.8 Release of branches

A branch may be dropped from the connection at any time while the connection is active. The dropping of a branch can be initiated either by the root or a leaf. Multiple drop branch requests pending at the same time are allowed.

Three scenarios apply:

- a) If the SN call control co-ordination function performs an en bloc release initiated by the root, the VB5.2 B-BCC application function is requested to initiate the release of the entire bearer connection in the AN.

The procedures described in subclause 13.5.5 apply.

- b) If the SN call control co-ordination function performs the release of a leaf which corresponds to the release of the last branch with respect to a particular VB5.2 reference point, the VB5.2 B-BCC application function is also requested to initiate the release of the entire bearer connection in the AN.

The procedures described in subclause 13.5.5 apply.

- c) If the SN call control co-ordination function performs the release of a leaf which does not correspond to the release of the last branch with respect to a particular VB5.2 reference point, the VB5.2 B-BCC application function is requested to initiate the release of that individual branch.

The procedures described in this subclause apply.

13.5.8.1 Branch release start in the SN

Trigger: A request from the call control co-ordination function to release a branch of a point-to-multipoint bearer connection in the AN is received.

Action: A `ceeDropBranchReq` primitive shall be passed to the SN B-BCC system.

13.5.8.2 Branch release in the AN

Trigger: A `ceeDropBranchInd` primitive is received.

Actions: The AN connection control function shall perform the following actions:

- The user port is disconnected from the service port.
- The allocated resources for the user port shall be made available for new traffic.

- The signalling association for the branch is terminated.
- The user port VPCI/VCI is made available for use by other connections.

Response: A `ceeDropBranchRes` primitive shall be passed to the AN B-BCC system.

13.5.8.3 Branch release termination in the SN

a) positive response from the SN B-BCC system:

Trigger: A `ceeDropBranchAccConf` primitive is received.

Actions:

- The call control co-ordination function is informed that the associated user port VPCI/VCI is available for new traffic.
- The allocated resources for the user port shall be made available for new traffic.
- The signalling association for the branch is terminated.

b) negative response from the SN VB5.2 B-BCC system:

Trigger: A `ceeDropBranchRejConf` primitive is received.

Actions: reject cause: transmission error:

- The connection control function continues to try to free up the resources in the AN. The resources in the SN are not released. It is up to the SN maintenance to decide what to do if the problem continues to exist.

reject cause: message not compatible with connection state.

- The SN connection control function informs the call control co-ordination function to release the connection. In addition, the release of the bearer connection in the AN shall be started.

reject cause: deallocation of last branch expected.

- Multiple actions on the VB5.2 reference point may for a certain time window result in the AN and SN having different views of branch states. The SN is the master and may either repeat the request or release the connection.

13.5.8.4 Use of en bloc drop branch

Besides the branch release with respect to a single branch of a point-to-multipoint connection it is also possible that the SN connection control function applies en bloc drop branch mechanism. It is applied during system restart. In this case, the `ceeDropBranchReq` primitive generated by the SN connection control function includes a list of branch identifiers belonging to a particular connection reference number. The list can contain more elements than can be carried by one message. It is the responsibility of the B-BCC system to perform the necessary segmentation.

After the branch release procedure has been completed, the SN connection control function receives a single `ceeDropBranchConf` primitive.

The AN connection control function is triggered by `ceeDropBranchInd` primitives, each containing a list of branch identifiers. For each branch identifier the branch release procedure is performed.

The AN connection control function passes one `ceeDropBranchAccRes` primitive per `ceeDropBranchInd` primitive to the AN B-BCC system.

13.5.9 Interworking with ANs not supporting point to multipoint connections

In order to support such ANs, the following procedure shall apply when the SN B-BCC connection control application receives from the destination AN an `ALLOC_ACC` message and it does not contain a branch identifier information element:

- The SN shall not treat as an error this or any subsequent messages related to the initial connection reference that are received without the branch ID information element.
- The SN in subsequent requests to the AN shall not use the ADD_BRANCH message but the ALLOC message. The branch identifier information element shall either be not included or the instruction field for that information element shall be coded to "discard information element and proceed".

13.5.10 AN fault procedure

If in the AN a fault condition occurs which has an impact on individual connections, the AN has the possibility to report the affected connections to the SN. The AN uses the ceeAnFaultReq primitive to trigger the AN B-BCC system.

On receipt of a ceeAnFaultInd primitive, the SN connection control function can, dependent on the received information (see 14.3.3.7):

- release the bearer connection;
- release the particular branch;
- reset the resource;
- ignore the information (e.g., if the resource is invalid).

In case of a transmission error, detected by the AN B-BCC system, the AN connection control function is informed via a ceeAnFaultRejConf primitive. The AN connection control function continues to inform the SN about the fault condition as long as the B-BCC protocol is active.

13.5.11 B-BCC Reset

The B-BCC reset function shall be used under abnormal conditions. It provides the means to return connection reference numbers, branch identifiers, bearer connection related resources and B-BCC system FSM to a defined condition. For the resource to be reset all affected connections are released and the resources are made available for new traffic.

A B-BCC reset has no impact on resources which are not under control of the B-BCC function (e.g. semi-permanent connections established via the Q3(SN) and Q3(AN) interfaces, including the VCCs carrying the RTMC and B-BCC protocols and signalling VCs).

The B-BCC reset can be invoked from the SN side under the following conditions:

- manually initiated by the SN operator;
- automatically initiated in order to resolve abnormal conditions;
- automatically initiated by the SN B-BCC system when a B-BCC start-up or B-BCC restart procedure is in progress (see subclause 13.6.4).

The B-BCC reset function can be initiated for the resources listed in table 18.

Table 18: Resources affected by the B-BCC reset function

Resource	Resource identifier	Remarks
LSP	LSP	
VPC	LUP/VPCI combination or LSP/VPCI combination	The B-BCC reset of a VPC can be triggered by an RTMC event or the restart of the user signalling protocol
VCC segment	LUP/VPCI/VCI combination or LSP/VPCI/VCI combination	If the complete connection exists in the AN then this connection is released. If only one part of the connection exists then this part is released.
VC-Link(branch)	LUP/VPCI/VCI combination	
VC-Link(root in AN)	LSP/VPCI/VCI combination	The entire multicast tree in the AN is released

13.5.11.1 B-BCC reset start at the SN

- Trigger: a) A request to reset a certain resource is received from call control co-ordination.
- b) The reset procedure is initiated in response to an indication from the AN e.g. `ceeAnFaultInd` primitive from the B-BCC system (see e.g. subclause 13.5.10).
- Action: A `ceeBbccResetReq` primitive shall be passed to the B-BCC system.

13.5.11.2 B-BCC reset at the AN

- Trigger: A `ceeBbccResetInd` primitive is received.
- Action: First the validity of the resource ID is checked. If the resource is known then the affected VCC's and VCL's are identified and the following actions are performed:
- The connectivity between service port and user port shall be released (if applicable).
 - The bandwidth/buffers shall be made available for new traffic.
 - The connection reference and/or the branch identifier is released.
 - The VCI value is made available for other connections.

Response: If the resource is known a `ceeBbccResetAccRes` primitive shall be returned.

NOTE: The B-BCC reset requests to set VCCs and/or VCLs to the idle state. If the resource is already in the idle state then still the reset is acknowledged positively.

If the B-BCC reset applies to a VPC and the VPCI is not known in the AN, then a `ceeBbccResetRejRes` primitive shall be returned with the appropriate cause (see table 57).

exceptional procedure:

If the AN has temporarily no access to resources to be released it is the responsibility of the AN to follow up the problem. The reset shall be acknowledged positively.

13.5.11.3 B-BCC reset termination in the SN

a) positive response from the SN B-BCC system:

- Trigger: A `ceeBbccResetConf` primitive is received.
- Action: The call control co-ordination is informed and the resources are set to the idle state and made available for new traffic.

b) negative response from the SN VB5.2 B-BCC system:

- Trigger: A `ceeBbccResetRejConf` is received.
- Action: reject cause: transmission error:
- The connection control function continues to try to free up the resources in the AN. The resources in the SN are not released. It is up to the SN maintenance to decide what to do if the problem continues to exist.

all other reject causes:

- The call control co-ordination function is informed and the resources in the SN are released.

13.5.11.4 Functionality in the AN to report abnormal conditions

The B-BCC reset procedure is an asymmetrical procedure and can be initiated at the SN only.

However, the AN has the capability to report abnormal conditions. Abnormal conditions in the AN which affect VPCs are reported to the SN via the RTMC protocol. In this case, the SN can then initiate a B-BCC reset procedure with respect to the relevant VPC.

Abnormal conditions in the AN at the VC level (e.g. detected by an AN internal audit procedure) shall be reported to the SN via the AN fault procedure provided by the B-BCC protocol (see subclause 13.5.10). In this case, the SN can then initiate a B-BCC reset procedure with respect to the relevant VCC or VC link.

13.5.12 B-BCC automatic congestion control functions

Automatic congestion control is used when the access network is in an overload condition (see ITU-T Recommendation Q.542 [56]). Two levels of congestion are distinguished, a less severe congestion threshold (congestion level 1) and a more severe congestion threshold (congestion level 2).

The detailed specification for the automatic congestion control as part of the VB5.2 application functions (e.g. congestion thresholds, reduction of traffic) is contained in ITU-T Recommendation Q.823 [57].

If either of the two congestion thresholds is reached, an automatic congestion level information element is included in all connection related acknowledgement messages from the AN to the SN. This information element indicates the level of congestion (congestion level 1 or 2) to the service node. The SN, when receiving this automatic congestion level information element should reduce its traffic to the overloaded access network.

If the overloaded access network returns to a normal traffic load, it will cease including automatic congestion level information elements in response messages.

The SN then, after a predetermined time, automatically returns to its normal status.

13.5.12.1 Actions taken during overload in the AN

Whenever an AN is in an overload state (congestion level 1 or 2), the overload control function of the VB5.2 management system will direct the connection control function to include an automatic congestion level information in every connection related response primitives.

The overload control function of the VB5.2 management system will indicate which congestion level (1 or 2) to code in the automatic congestion level information element.

When the overload condition has ended, the overload control function of the VB5.2 management system will direct the connection control to cease including the automatic congestion level information element in the connection related response primitives.

13.5.12.2 Receipt of primitives by the SN connection control function containing an automatic congestion level parameter

When a confirmation primitive is received containing an automatic congestion level information element, the connection control should pass the appropriate information to the signalling system independent network management/overload control function within the SN. This information consists of the received congestion level information and the AN/LSP identification to which the congestion level applies.

13.5.13 Establishment of (semi-)permanent connections via the B-BCC protocol

The cee primitive interface between SN connection control and the SN B-BCC system can also be used for the establishment, modification and release of soft PVC's between AN and SN. No additional functionality for these PVC is provided at the primitive interface. The AN is not aware whether a bearer connection is used to support a switched call or to provide a soft PVC.

It is the task of SN management application:

- to control the SN internal interface to call control co-ordination function;
- to perform the appropriate recovery actions when events such as:

- receipt of an AN fault indication;
- B-BCC reset, B-BCC restart or B-BCC start-up,
have occurred;
- to do the required co-ordination with the RTMC function.

13.6 B-BCC communication procedures

13.6.1 General principles for the B-BCC procedures

This subclause describes common principles and mechanisms of the B-BCC communication procedures defined for the VB5.2 reference point.

13.6.1.1 Overview of B-BCC communication mechanism

The B-BCC communication procedures are based on protocol transactions. In general a transaction consists of a pair of a requesting message together with the corresponding acknowledgement (i.e., accept or reject message) and is identified by a transaction identifier.

A B-BCC transaction is initiated by an invoke message and terminated by the corresponding acknowledgement message.

The general B-BCC communication mechanism without any exceptional cases is described below and illustrated in figure 22.

- a) A transaction shall be triggered by the VB5.2 application functions via a request primitive.
- b) The B-BCC system processes the request and sends an invoke message to the peer side. The timer for the transaction is started.
- c) On receipt of the invoke message, the B-BCC system at the peer network element indicates the request via an indication primitive to the VB5.2 application functions.
- d) The VB5.2 application functions at the peer network element processes the request and returns the result via a response primitive to the B-BCC system.
- e) The B-BCC system at the peer side sends an acknowledgement message back to the network element where the request was initiated.
- f) On receipt of the acknowledgement message, the B-BCC system at the initiating side stops the transaction timer and notifies the VB5.2 application functions.

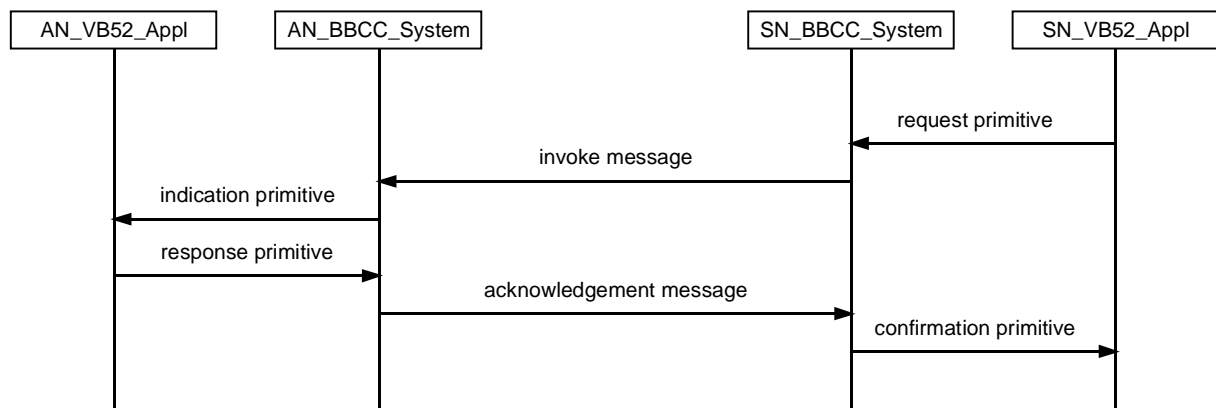

Figure 22: General B-BCC communication mechanism (initiated by SN)

13.6.1.2 Acknowledgements

The VB5.2 B-BCC protocol makes use of the assured data transfer mode of SAAL. SAAL takes care for the transport of the messages. In addition functional acknowledgements for all applications using the B-BCC protocol are introduced to keep the synchronization between AN and SN as close as possible. The receiving application either returns a positive response, if it will execute or has executed the requested action(s) or returns a negative response if the requested action(s) can not be performed.

13.6.1.3 Use of transaction identifiers

The use of transaction identifiers is specified in subclause 13.3.1.4 of EN 301 005-1 [1].

13.6.1.4 Use of connection reference numbers and branch identifiers

a) Connection reference numbers

The purpose of the connection reference number is to identify the bearer connection to which a particular B-BCC message applies. In case of a point-to-multipoint bearer connection the connection reference number identifies the root and the branches of the connection as a whole.

The connection reference number is assigned by the SN connection control function before the first transaction of the connection establishment procedure is initiated. The connection reference number value shall be unique within an LSP, i.e. a B-BCC instance, and remains fixed for the lifetime of the bearer connection. It shall be released after the last transaction related to the bearer connection has been terminated.

After the connection is released, the associated connection reference number may be reassigned to a later connection.

b) Branch identifiers

The purpose of the branch identifier is to identify the branch of a point-to-multipoint bearer connection to which a particular B-BCC message applies.

The branch identifier is assigned by the SN connection control function before the first transaction of the branch establishment procedure is initiated. The branch identifier value shall be unique within a connection reference number, i.e. a bearer connection instance, and remains fixed for the lifetime of the branch. It shall be released after the last transaction related to the branch has been terminated.

After the branch is released, the associated branch identifier may be reassigned to a later branch.

To avoid race conditions in certain error scenarios, it is suggested that implementers avoid immediate re-use of the connection reference numbers and branch identifiers after they are released.

13.6.1.5 General error handling

This subclause provides the general description for exceptional procedures. They apply to all of the procedures described in the following subclauses, unless otherwise specified.

13.6.1.5.1 Handling of protocol syntax error conditions

The handling of protocol syntax error conditions as specified in subclause 13.3.1.5.1 of EN 301 005-1 [1] applies, except for the handling of message sequence errors.

Message sequence errors are procedural B-BCC errors and shall be handled as specified in subclause 13.6.1.5.4.

13.6.1.5.2 Error procedures with explicit action indication

The procedures to be used only if the flag of the message compatibility instruction indicator or information element instruction field is set to "follow explicit instructions" are defined in subclause 14.1 of EN 301 005-1 [1].

13.6.1.5.3 Transmission error in communication with peer network element

It is the task of the B-BCC protocol entity to supervise the acknowledgement messages by timers. The timer values shall be application dependent. In the case of time out the messages are repeated once. After the second time out the B-BCC system shall locally report the error condition by sending a negative confirmation or an error indication to the VB5.2 application functions.

13.6.1.5.4 Procedural B-BCC errors

Whenever an unexpected invoke message is received, this shall be reported to the invoke network element by sending the corresponding reject message. Dependent on the particular error type, the reject cause shall indicate either "message not compatible with connection state" or "message not compatible with branch state".

Whenever an unexpected acknowledgement message (i.e., accept or reject message) is received, this message shall be ignored.

13.6.1.5.5 Requested operation rejected by peer network element

When the environment at the peer network element (i.e., the receiving application within the environment) can not accept or perform the requested operation, this shall be reported to the invoke network element by sending the relevant reject message. The reject cause shall indicate the reason why the request has not been accepted.

13.6.1.6 Timers used in B-BCC procedures

Two types of timers are used within the B-BCC procedures:

- a) Timers for supervision of individual transactions;
- b) Timers for supervision of procedures which consist of multiple transactions.

The description of timers given in table 19 is a brief summary. The detailed specification including the causes for start, stop and actions in case of expiry is provided in annex A.

Table 19: Timers used in B-BCC procedures

Name	Location		Default value	Supervision of
	AN	SN		
Timers to supervise individual transactions				
T_AnFault	X		15 sec	AN fault transaction
T_Alloc		X	15 sec	Allocation transaction
T_AllocComp		X	15 sec	Allocation complete transaction
T_BbccReset		X	30 sec	B-BCC reset transaction
T_BbccPresync		X	15 sec	B-BCC presync transaction
T_Dealloc		X	30 sec	Deallocation transaction
T_Modify		X	15 sec	Modification transaction
T_ModifyComp		X	15 sec	Modification complete transaction
T_ModifyAbort		X	15 sec	Modification abort transaction
T_AddBranch		X	15 sec	Add branch transaction
T_UpdateBranch		X	15 sec	Update branch transaction
T_DropBranch		X	30 sec	Drop branch transaction
Timers to supervise procedures consisting of multiple transactions				
T_ConnEst	X		180 sec	Connection establishment procedure
T_Modification	X		180 sec	Connection modification procedure
T_BranchEst	X		180 sec	Branch establishment procedure
T_BbccStartup		X	180 sec	B-BCC start-up procedure
T_BbccRestart		X	180 sec	B-BCC restart procedure

13.6.1.7 Segmentation of requests into individual transactions

The SAAL transfers service data units with a maximum length of 4 096 octets.

For some B-BCC procedures which use list information elements (e.g., bearer connection release procedure, branch release procedure), the B-BCC system at the initiating side may receive a request primitive from the VB5.2 application function which cannot be mapped to a single B-BCC message. In this case, the B-BCC system shall decompose the list into sub-lists which can be carried in individual B-BCC messages and invoke a B-BCC transaction per sub-list.

For the VB5.2 application functions at the initiating side, the decomposition shall be transparent and a single confirmation primitive is expected in response to the request.

For the B-BCC system and the VB5.2 application functions at the peer side, the decomposition is not visible because a number of independent B-BCC transactions are initiated.

13.6.2 Procedures for establishment and release of bearer connections

13.6.2.1 Bearer connection establishment procedure

13.6.2.1.1 General

The bearer connection establishment procedure provides the communication procedures between SN and AN VB5.2 application functions to enable the establishment of a bearer connection in the AN. The bearer connection is either a point-to-point connection or the root including the first branch of a point-to-multipoint connection in the AN.

13.6.2.1.2 Procedure

The bearer connection establishment procedure consists of two separate transactions: allocation and allocation complete. The first transaction is used to reserve resources for the bearer connection. The second transaction completes the allocation of resources.

a) Allocation

This transaction is triggered at the SN B-BCC system by the SN VB5.2 application functions via a `ceeAlloqReq` primitive. This primitive contains relevant bearer connection parameters. In case of a point-to-multipoint bearer connection to be established, it contains the identifier for the first branch.

On receipt of the `ALLOC` message, the AN B-BCC system indicates the request to the AN VB5.2 application function.

Depending on the decision made by the AN VB5.2 application functions, either an `ALLOC_ACC` or an `ALLOC_REJ` message will be sent back to the SN. The `ALLOC_ACC` message may contain bearer connection parameters which have been selected or changed by the AN.

b) Allocation complete

This transaction is triggered at the SN B-BCC system by the SN VB5.2 application functions via a `ceeAllocCompReq` primitive. This primitive may contain any final bearer connection parameters to be used by the AN to allocate the resources.

On receipt of the `ALLOC_COMP` message, the AN B-BCC system indicates the request to the AN VB5.2 application function.

Depending on the decision made by the AN VB5.2 application functions, either an `ALLOC_COMP_ACC` or an `ALLOC_COMP_REJ` message will be sent back to the SN.

13.6.2.1.3 Exceptional procedures

In addition to the general error handling described in subclause 13.6.1.5, the following rules apply:

- a) When the AN B-BCC system receives an `ALLOC` message containing a connection reference number which is already assigned in the AN, no action shall be taken on the message and a `ALLOC_REJ` message containing a reject cause value of "message not compatible with connection state" shall be sent to the SN.

- b) When, after successful completion of the allocation transaction, the AN does not receive an ALLOC_COMP message (i.e., timer T_ConnEst expires), the AN B-BCC system shall send a deallocation indication to the AN VB5.2 application function and set the connection state to the idle condition. No message shall be sent to the SN.

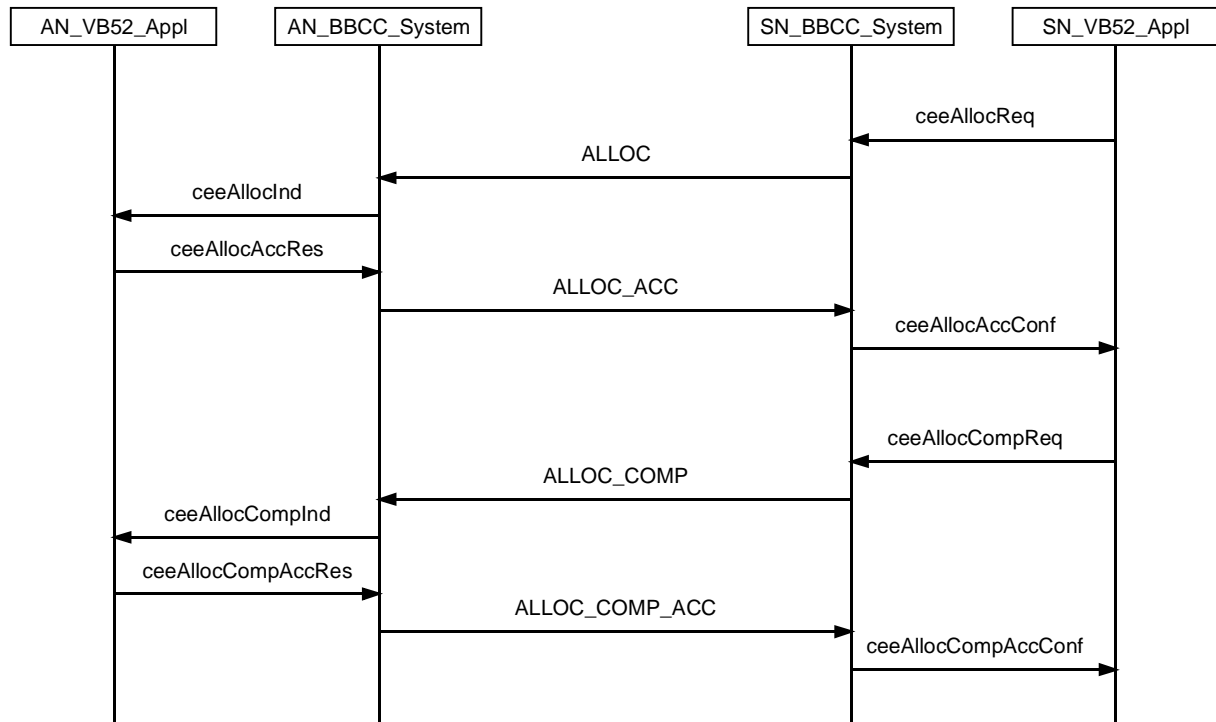

Figure 23: Connection establishment procedure (successful)

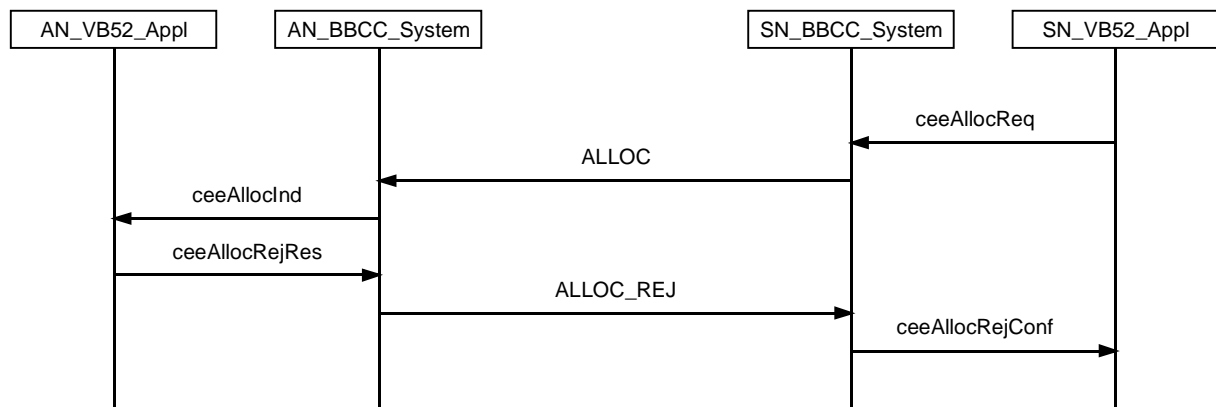

Figure 24: Connection establishment procedure (allocation unsuccessful)

13.6.2.2 Bearer connection release procedure

13.6.2.2.1 General

The bearer connection release procedure provides the communication procedures between SN and AN VB5.2 application functions to enable the release of bearer connections in the AN. In case of a point-to-multipoint connection, the procedure results in the release of the entire connection in the AN, i.e. the root at the VB5.2 reference point and all branches in the AN.

The procedure supports the release of a single connection as well as the release of a set of connections.

13.6.2.2.2 Procedure

The bearer connection release procedure consists of a single transaction. It is triggered at the SN B-BCC system by the SN VB5.2 application functions via a `ceeDeallocReq` primitive. This primitive contains either a single connection reference or a list of connection references. In case of a list which would result in a `DROP_BRANCH` message exceeding the maximum message length, the segmentation mechanism described in subclause 13.6.1.7 shall be applied.

On receipt of the `DEALLOC` message, the AN B-BCC system indicates the request to the AN VB5.2 application function.

After the connection(s) have been released in the AN, a `DEALLOC_ACC` message will be sent back to the SN.

13.6.2.2.3 Exceptional procedures

In addition to the general error handling described in subclause 13.6.1.5, the following rules apply:

When the AN B-BCC system receives a `DEALLOC` message containing one or several connection reference numbers which are unknown in the AN, actions shall be taken on those connection reference numbers which are assigned in the AN. Only these connection reference numbers shall be included into the `ceeDeallocInd` primitive which is passed to the AN VB5.2 application function. After the connection(s) have been released in the AN, a `DEALLOC_ACC` message shall be sent to the SN.

If all connection reference numbers are unknown in the AN, no action shall be taken on the message and a `DEALLOC_ACC` message shall be sent to the SN.

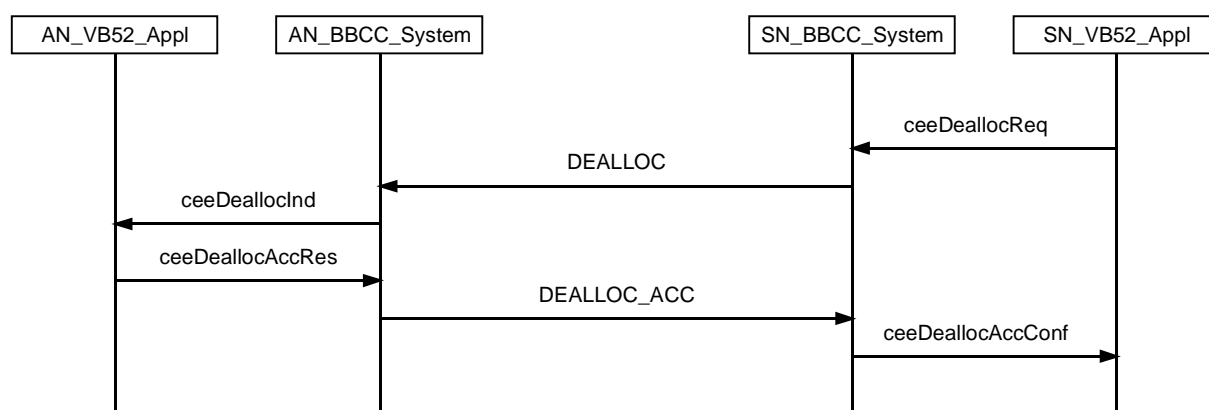

Figure 25: Connection release procedure

13.6.2.3 Bearer connection modification procedure

13.6.2.3.1 General

The bearer connection modification procedure provides the communication procedures between SN and AN VB5.2 application functions to enable the modification of traffic parameters of a bearer connection in the AN.

This procedure is not applicable to point-to-multipoint connections.

13.6.2.3.2 Procedure

The bearer connection modification procedure consists of two separate transactions: modification and modification complete. The first transaction is used to check whether the modification of traffic parameters is possible in the AN. The second transaction completes or aborts the modification.

a) Modification

This transaction is triggered at the SN B-BCC system by the SN VB5.2 application functions via a `ceeModifyReq` primitive. This primitive contains the relevant traffic parameters.

On receipt of the MODIFY message, the AN B-BCC system indicates the request to the AN VB5.2 application function.

Depending on the decision made by the AN VB5.2 application functions, either a MODIFY_ACC or an MODIFY_REJ message will be sent back to the SN. In case of traffic parameter negotiation, the MODIFY_ACC message may contain traffic parameters which have been changed by the AN.

b) Modification complete

This transaction is triggered at the SN B-BCC system by the SN VB5.2 application functions via a ceeModifyCompReq primitive. This primitive may contain the final traffic parameters to be used by the AN to allocate the resources.

On receipt of the MODIFY_COMP message, the AN B-BCC system indicates the request to the AN VB5.2 application function.

Depending on the decision made by the AN VB5.2 application functions, either an MODIFY_COMP_ACC or an MODIFY_COMP_REJ message will be sent back to the SN.

After the first transaction, the SN may decide to abort the modification procedure in progress. In this case, the modification abort transaction described below is applied instead of the modification complete transaction.

c) Modification abort

This transaction is triggered at the SN B-BCC system by the SN VB5.2 application functions via a ceeModifyAbortReq primitive.

On receipt of the MODIFY_ABORT message, the AN B-BCC system indicates the request to the AN VB5.2 application function.

Depending on the decision made by the AN VB5.2 application functions, either an MODIFY_ABORT_ACC or an MODIFY_ABORT_REJ message will be sent back to the SN.

13.6.2.3.3 Exceptional procedures

In addition to the general error handling described in subclause 13.6.1.5, the following rules apply:

- a) When the AN B-BCC system receives a MODIFY message with respect to a connection which has not been established or a connection release procedure is in progress, no action shall be taken on the message and a MODIFY_REJ message containing a reject cause value of "message not compatible with connection state" shall be sent to the SN.
- b) When the AN B-BCC system receives a MODIFY message with respect to a point-to-multipoint connection, no action shall be taken on the message and a MODIFY_REJ message containing a reject cause value of "message not compatible with connection state" shall be sent to the SN.
- c) When, after successful completion of the modification transaction, the AN receives neither a MODIFY_COMP nor a MODIFY_ABORT message (i.e., timer T_Modification expires), the AN B-BCC system shall send an AN_FAULT message to the SN.

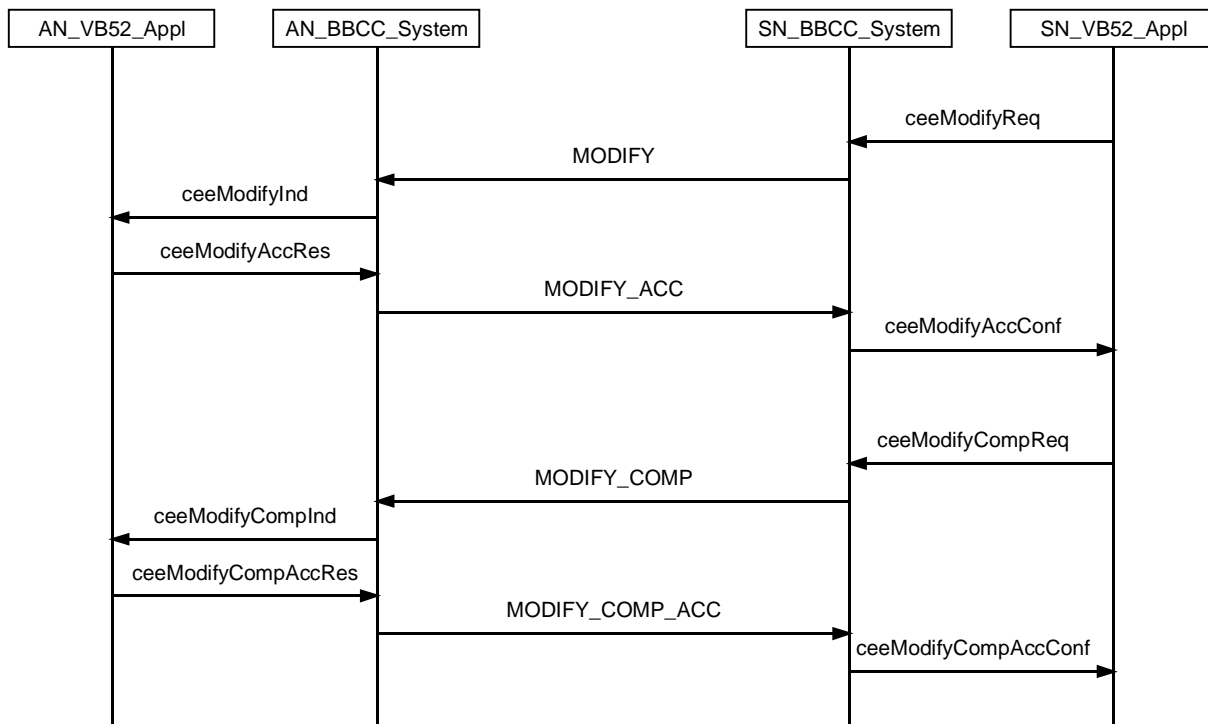

Figure 26: Connection modification procedure (successful)

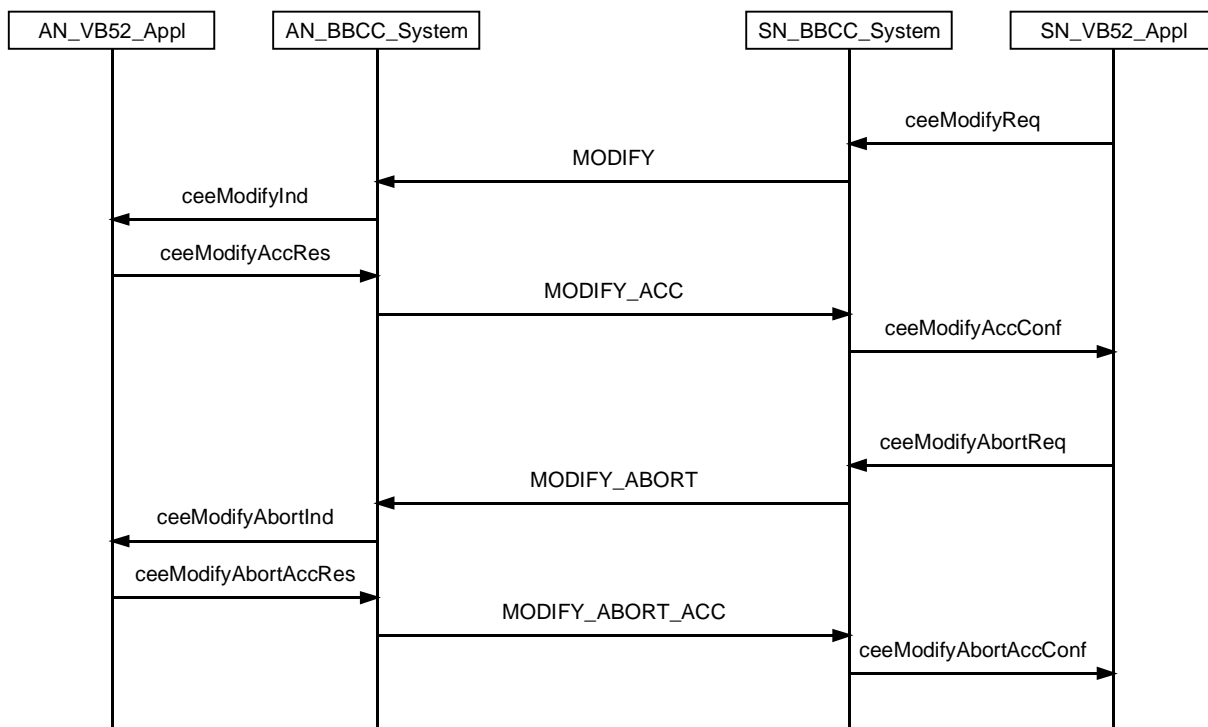

Figure 27: Connection modification procedure (modification aborted by SN)

13.6.3 Procedures specific for point-to-multipoint connections

13.6.3.1 Branch establishment procedure

13.6.3.1.1 General

The branch establishment procedure provides the communication procedures between SN and AN VB5.2 application functions to enable the establishment of an additional branch of an existing point-to-multipoint connection in the AN.

13.6.3.1.2 Procedure

The bearer connection establishment procedure consists of two separate transactions: add branch and update branch. The second transaction is only present for specific cases.

a) Add branch

This transaction is triggered at the SN B-BCC system by the SN VB5.2 application functions via a `ceeAddBranchReq` primitive. This primitive contains relevant branch parameters.

On receipt of the `ADD_BRANCH` message, the AN B-BCC system indicates the request to the AN VB5.2 application function.

Depending on the decision made by the AN VB5.2 application functions, either an `ADD_BRANCH_ACC` or an `ADD_BRANCH_REJ` message will be sent back to the SN. The `ADD_BRANCH_ACC` message may contain branch parameters which have been selected by the AN.

If and only if the user port connection information transferred by the add branch transaction was not complete, the update branch transaction described below is applied after the successful add branch transaction.

b) Update branch

This transaction is triggered at the SN B-BCC system by the SN VB5.2 application functions via a `ceeUpdateBranchReq` primitive. This primitive contains the complete user port connection parameters to be used by the AN to allocate the resources for the additional branch.

On receipt of the `UPDATE_BRANCH` message, the AN B-BCC system indicates the request to the AN VB5.2 application function.

Depending on the decision made by the AN VB5.2 application functions, either an `UPDATE_BRANCH_ACC` or an `UPDATE_BRANCH_REJ` message will be sent back to the SN.

13.6.3.1.3 Exceptional procedures

In addition to the general error handling described in subclause 13.6.1.5, the following rules apply:

- a) When the AN B-BCC system receives an `ADD_BRANCH` message with respect to a connection which has not been established or a connection release procedure is in progress, no action shall be taken on the message and an `ADD_BRANCH_REJ` message containing a reject cause value of "message not compatible with connection state" shall be sent to the SN.
- b) When the AN B-BCC system receives an `ADD_BRANCH` message containing a connection reference number/branch identifier combination which is already assigned in the AN, no action shall be taken on the message and an `ADD_BRANCH_REJ` message containing a reject cause value of "message not compatible with connection state" shall be sent to the SN.
- c) When the AN B-BCC system receives an `ADD_BRANCH` message with respect to a point-to-point connection, no action shall be taken on the message and an `ADD_BRANCH_REJ` message containing a reject cause value of "message not compatible with connection state" shall be sent to the SN.

- d) When, after successful completion of the add branch transaction, the AN does not receive an expected UPDATE_BRANCH message (i.e., timer T_BranchEst expires), the AN B-BCC system shall send a drop branch indication to the AN VB5.2 application function and set the branch state to the idle condition. No message shall be sent to the SN.

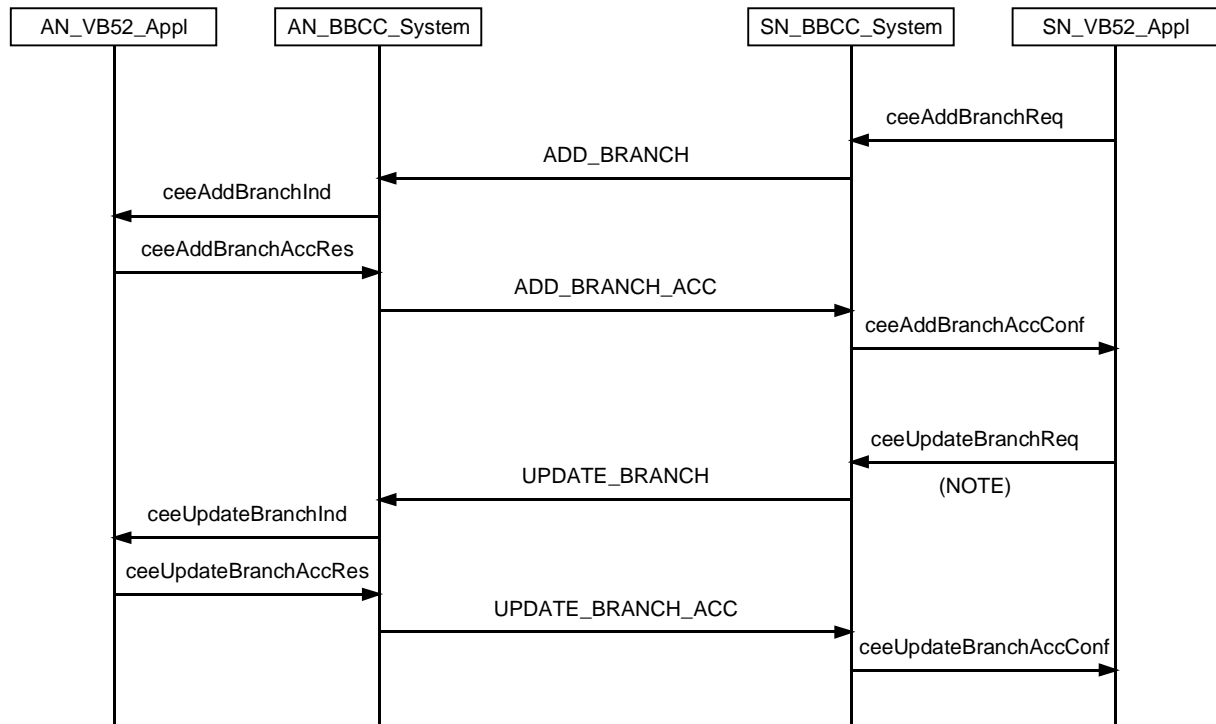

NOTE: The update branch transaction is only present if the user port connection information transferred by the add branch transaction was not complete.

Figure 28: Branch establishment procedure (successful)

13.6.3.2 Branch release procedure

13.6.3.2.1 General

The branch release procedure provides the communication procedures between SN and AN VB5.2 application functions to enable the release of a branch in the AN.

The procedure supports the release of a single branch as well as the release of a set of branches of a given bearer connection.

13.6.3.2.2 Procedure

The branch release procedure consists of a single transaction. It is triggered at the SN B-BCC system by the SN VB5.2 application functions via a ceeDropBranchReq primitive. This primitive contains either a single branch identifier or a list of branch identifiers. In case of a list which would result in a DROP_BRANCH message exceeding the maximum message length, the segmentation mechanism described in subclause 13.6.1.7 shall be applied.

On receipt of the DROP_BRANCH message, the AN B-BCC system indicates the request to the AN VB5.2 application function.

After the branch(es) have been released in the AN, a DROP_BRANCH_ACC message will be sent back to the SN.

13.6.3.2.3 Exceptional procedures

In addition to the general error handling described in subclause 13.6.1.5, the following rules apply:

- a) When the AN B-BCC system receives a DROP_BRANCH message containing a connection reference number which is unknown in the AN, no action shall be taken on the message and a DROP_BRANCH_REJ message containing a reject cause of "message not compatible with connection state" shall be sent to the SN.
- b) When the AN B-BCC system receives a DROP_BRANCH message containing a connection reference number assigned in the AN but containing one or several branch identifiers which are unknown in the AN, actions shall be taken on those branch identifiers which are assigned in the AN. Only these branch identifiers shall be included into the ceeDropBranchInd primitive which is passed to the AN VB5.2 application function. After the branch(es) have been released in the AN, a DROP_BRANCH_ACC message shall be sent back to the SN.

If all branch identifiers are unknown in the AN, no action shall be taken on the message and a DROP_BRANCH_ACC message shall be sent to the SN.

- c) When the AN B-BCC system receives a DROP_BRANCH message which requests actions that would result in no branches remaining in the AN, no action shall be taken on the message and a DROP_BRANCH_REJ message containing a reject cause of "deallocation of last branch expected" shall be sent to the SN.

13.6.4 B-BCC housekeeping procedures

13.6.4.1 B-BCC reset procedure

13.6.4.1.1 General

The B-BCC reset procedure provides the communication procedures between SN and AN VB5.2 application functions to reset a resource which is under control of the B-BCC to the idle state (i.e., no bearer connections are established on the resource).

13.6.4.1.2 Procedure

The B-BCC reset procedure consists of a single transaction. It is triggered at the SN B-BCC system:

- by either the SN VB5.2 application functions via a ceeBbccResetReq primitive.
- or automatically by the SN B-BCC system when a B-BCC start-up or B-BCC restart is in progress. In this case, the B-BCC reset always applies to the complete LSP.

On receipt of the BBCC_RESET message, the AN B-BCC system indicates the request to the AN VB5.2 application function.

After the reset of the indicated resource has been performed, a BBCC_RESET_ACC message will be sent back to the SN.

13.6.4.1.3 Exceptional procedures

The general error handling described in subclause 13.6.1.5 applies.

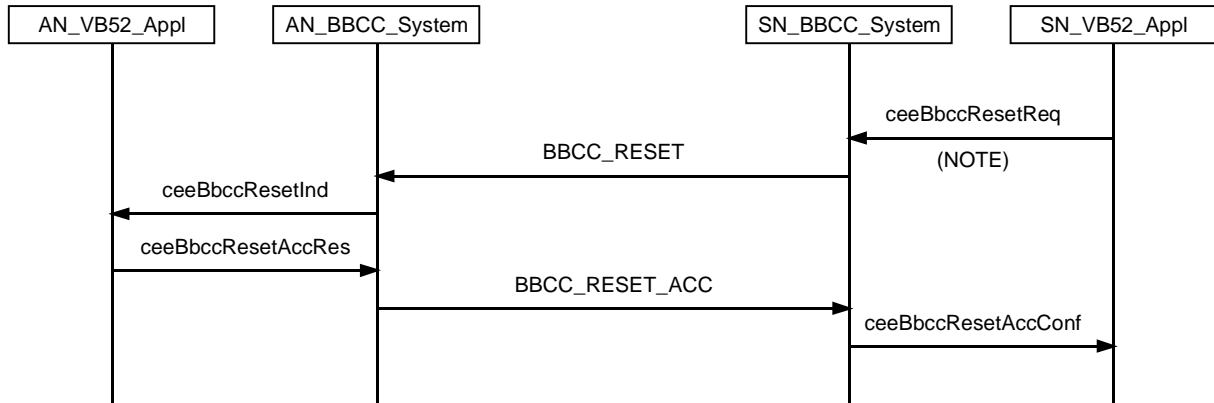

NOTE: When a B-BCC start-up or B-BCC restart procedure is in progress, the B-BCC reset procedure can also be initiated automatically by the SN B-BCC system. In this case, no `ceeBbccResetAccConf` primitive is sent to the SN VB5.2 application function.

Figure 29: B-BCC reset procedure (successful operation)

13.6.4.2 AN fault procedure

13.6.4.2.1 General

The AN fault procedure provides the communication procedures between AN and SN VB5.2 application functions to report a fault condition related to a bearer connection or a particular branch to the SN.

13.6.4.2.2 Procedure

The AN fault procedure consists of a single transaction. It is triggered at the AN B-BCC system:

- either by the AN VB5.2 application functions via a `ceeAnFaultReq` primitive;
- or automatically within the AN B-BCC system in certain error situations (e.g. expiry of `T_Modification`).

The `AN_FAULT` message shall contain a connection reference number and may contain a branch identifier. If, due to the error situation, the AN is not able to use the connection reference number and/or branch identifier, it may use a resource identifier indicating the respective VCC or the VC link.

On receipt of the `AN_FAULT` message, the SN B-BCC system notifies the SN VB5.2 application function and an `AN_FAULT_ACC` message is sent back to the AN.

13.6.4.2.3 Exceptional procedures

In addition to the general error handling described in subclause 13.6.1.5, the following rules apply:

- a) When the SN B-BCC system receives an `AN_FAULT` message containing a connection reference number which is unknown in the SN, the SN B-BCC system shall also notify the SN VB5.2 application function and an `AN_FAULT_ACC` message shall be sent back to the AN.

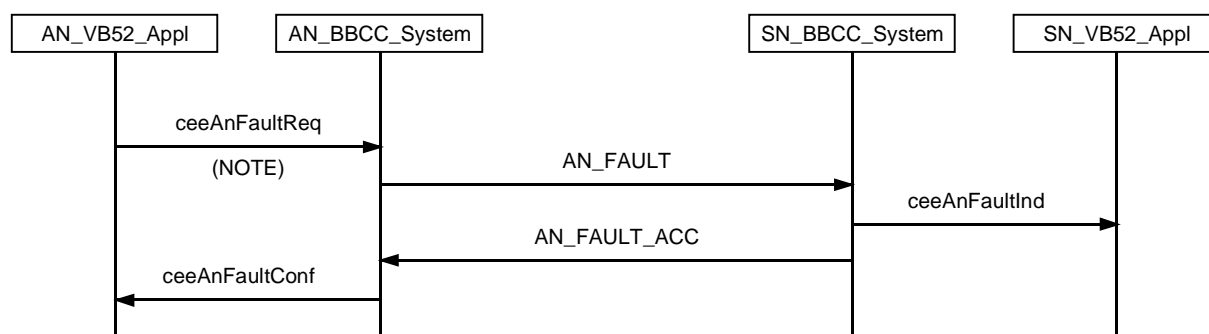

NOTE: In certain error situations, the AN fault procedure can also be initiated automatically by the AN B-BCC system. In this case, no ceeAnFaultConf primitive is sent to the AN VB5.2 application function.

Figure 30: AN fault procedure

13.6.4.3 B-BCC pre-synchronization procedure

13.6.4.3.1 General

The B-BCC pre-synchronization procedure is part of the B-BCC restart procedure described in subclause 13.6.4.6. It provides the communication procedures to find out whether the B-BCC protocol can resume its normal operation or a B-BCC reset should be initiated.

13.6.4.3.2 Procedure

The B-BCC pre-synchronization procedure consists of a single transaction. It is triggered at the SN B-BCC system within the B-BCC restart procedure.

On receipt of the BBCC_PRESYNC message, the AN B-BCC system indicates the request to the AN VB5.2 application function.

Depending on the decision made by the AN VB5.2 application functions, either a BBCC_PRESYNC_ACC or a BBCC_PRESYNC_REJ message will be sent back to the SN.

13.6.4.3.3 Exceptional procedures

The general error handling described in subclause 13.6.1.5 applies.

13.6.4.4 SAAL establishment procedure

13.6.4.4.1 General

The SAAL establishment procedure provides the procedures to establish the SAAL connection supporting the B-BCC protocol.

The functionality of SSCOP allows that short term problems are handled by SSCOP recovery actions. If the "NoResponse" timer of SSCOP expires and the B-BCC system is informed via the AAL release indication, it assumes that a non-recoverable error occurred. The VB5.2 application function is informed. It is the task of the VB5.2 application function to trigger the appropriate recovery action (e.g., generation of a meeBccStartupReq or meeBbccRestartReq primitive in the SN, generation of meeBbccStartTrafficReq primitive in the AN).

13.6.4.4.2 Procedure

The SAAL establishment procedure is triggered:

- either by the AN VB5.2 application function via the meeBbccStartTrafficReq primitive;
- or automatically by the SN B-BCC system when a B-BCC start-up or B-BCC restart is in progress.

The SAAL entity of the AN and SN, respectively, is then triggered by the B-BCC system via the `aalBbccEstablishReq` primitive.

When the establishment of the SAAL has been successfully completed, the B-BCC system at the peer side is informed by its SAAL entity via the `aalBbccEstablishInd` primitive. The (local) B-BCC system is informed by the SAAL entity via the `aalBbccEstablishConf` primitive.

13.6.4.4.3 Exceptional procedure

When the establishment of the SAAL fails, two scenarios apply:

- When the SAAL establishment was initiated by the AN, the AN VB5.2 application functions are informed via a negative `meeBbccStartTrafficConf` primitive.
- When the SAAL establishment was initiated by the SN, the higher level procedure in progress (i.e., B-BCC start-up or restart) shall be stopped and the SN VB5.2 application functions be informed.

13.6.4.5 B-BCC start-up procedure

13.6.4.5.1 General

The B-BCC start-up procedure provides the communication procedures between SN and AN to initialize the B-BCC protocol entities by setting them to the idle state (i.e., no bearer connections are established at the VB5.2 reference point).

The B-BCC start-up procedure can be initiated by the following external events:

- a) B-BCC start-up request from the SN operator.
- b) Indication from the SAAL instance that the SAAL for the B-BCC protocol has been established by the AN. However, in this case, a B-BCC start-up shall only be initiated if the bearer connections cannot be retained from an SN point of view. Otherwise the SN shall initiate a B-BCC restart as described in subclause 13.6.4.6.

As long as the B-BCC start-up procedure is in progress, the B-BCC protocol shall still be inactive (i.e., other B-BCC transactions are not possible). When the procedure has been successfully completed, the B-BCC protocol is active and fully operable.

13.6.4.5.2 Procedure

The procedure is triggered at the SN B-BCC system via the `meeBbccStartupReq` primitive and includes the following steps as illustrated in figure 31:

- a) Establishment of the SAAL (see subclause 13.6.4.4), if the SAAL for the B-BCC protocol is not yet established.
- b) B-BCC reset of the complete LSP (see subclause 13.6.4.1).

When both steps have been successfully completed, the B-BCC protocol is active and the B-BCC function is fully operable.

13.6.4.5.3 Exceptional procedures

In addition to the general error handling described in subclause 13.6.1.5, the following rules apply:

- a) When one of the particular procedures cannot be successfully completed, the B-BCC start-up procedure is stopped and a negative confirmation is passed to the SN VB5.2 application functions. It is the task of the SN to take the appropriate actions to recover from the failure situation.

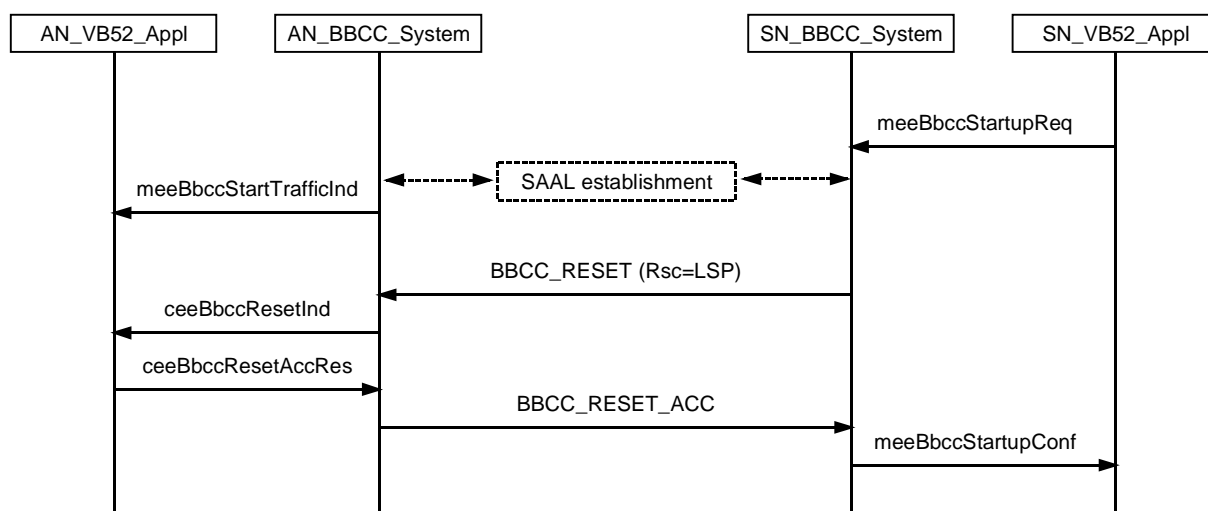

Figure 31: B-BCC start-up procedure

13.6.4.6 B-BCC restart procedure

13.6.4.6.1 General

The B-BCC restart procedure provides the communication procedures between SN and AN to restart the B-BCC protocol entities when the B-BCC protocol has become inactive due to any reasons. The procedure includes a mechanism to check whether the AN has retained the established bearer connections during the period the B-BCC was not available. If possible, the B-BCC restart procedure retains established bearer connections.

The B-BCC restart procedure can be initiated by the following external events:

- Failure of the SAAL of the B-BCC protocol detected by the SN.
- Indication from the SAAL instance that the SAAL for the B-BCC protocol has been established by the AN. However, in this case, a B-BCC restart shall only be initiated if the bearer connections can be retained from an SN point of view. Otherwise the SN shall initiate a B-BCC start-up as described in subclause 13.6.4.5.

As long as a B-BCC re-start procedure is in progress, the B-BCC protocol shall be suspended (i.e., other B-BCC transactions are not possible). When the procedure has been successfully completed, the B-BCC protocol is active and fully operable.

If bearer connections could be maintained over the B-BCC restart, the B-BCC protocol entities in the SN and AN have to be synchronized. The SN, after completion of the B-BCC restart which retained bearer connections, shall therefore initiate the release of those connections and/or branches in the AN which need not or cannot be maintained from an SN point of view.

13.6.4.6.2 Procedure

The procedure is triggered at the SN B-BCC system via the meeBbccRestartReq primitive and includes the following steps as illustrated in figure 32:

- Establishment of the SAAL (see subclause 13.6.4.4), if the SAAL for the B-BCC protocol is not established.
- B-BCC pre-synchronization of the complete LSP (see subclause 13.6.4.2). If this step results in a BBCC_PRESYNC_ACC message received from the AN, the B-BCC restart procedure is completed.
- B-BCC reset of the complete LSP (see subclause 13.6.4.1). This step shall only be performed if the B-BCC pre-synchronization procedure resulted in a BBCC_PRESYNC_REJ message received from the AN.

When all relevant steps have been successfully completed, the B-BCC protocol is active and the B-BCC function is fully operable.

The B-BCC restart procedure itself does not include the synchronization of the B-BCC protocol entities. The synchronization is performed after the completion of the B-BCC restart via connection release and branch release procedures, respectively.

13.6.4.6.3 Exceptional procedures

In addition to the general error handling described in subclause 13.6.1.5, the following rules apply:

- a) When one of the particular procedures cannot be successfully completed, the B-BCC restart procedure is stopped and a negative confirmation is passed to the SN VB5.2 application functions. It is the task of the SN to take the appropriate actions to recover from the failure situation.

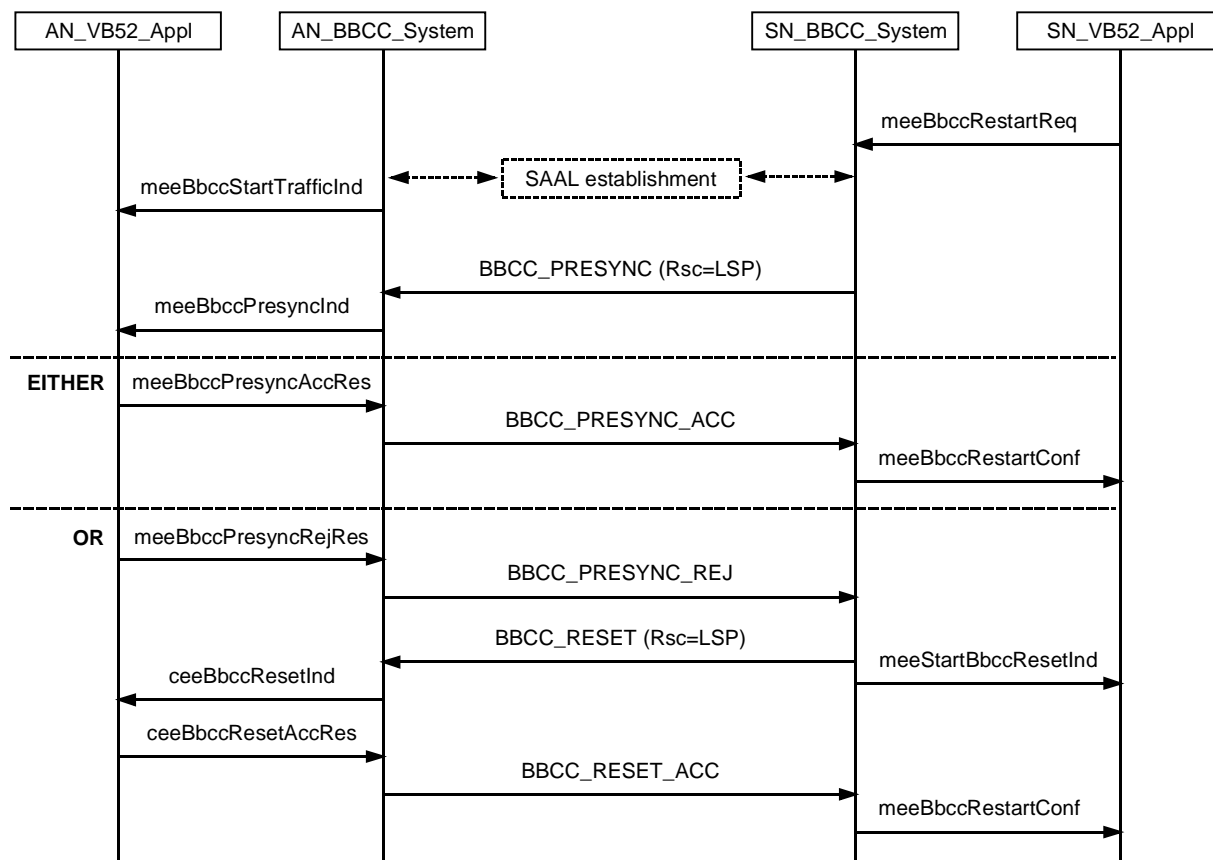

Figure 32: B-BCC restart procedure

14 Message format and codes

This clause defines the message format and the coding of the information elements. For each information element the coding of the different fields is provided.

Within each octet, the bit designated "bit 1" shall be transmitted first, followed by bits 2, 3, 4, etc.

Similarly, the octet shown at the top of each figure shall be sent first.

14.1 Message and information element encoding principles

The message and information element encoding principles defined in subclause 14.1 of EN 301 005-1 [1] apply.

The encodings for the message types and information element types are defined as follows:

- a) The encodings for RTMC protocol message types and information element types are specified in subclause 14.1 (tables 35 and 36) of EN 301 005-1 [1].
- b) The encodings for B-BCC protocol message types and information element types are specified in subclause 14.3 (tables 21 and 53).

14.2 RTMC protocol messages and information elements

The contents of this subclause are identical to subclause 14.2 of EN 301 005-1 [1].

14.3 B-BCC protocol messages and information elements

This subclause provides an outline of the VB5.2 B-BCC message structures, including the functional definition and information content of each message. Each message definition includes:

- a) a brief description of the message use;
- b) a table listing the information elements. For each information element, the table indicates:
 - 1) the subclause of the present document describing the information element;
 - 2) whether inclusion is mandatory (M) or optional (O), with a reference to notes explaining the circumstances under which the information element shall be included; and
 - 3) the length of the information element (or permissible range of lengths), in octets.

The specific variable length information elements within a VB5.2 B-BCC message may appear in any order except for the following case: If information elements are repeated the following rules applies:

- The second occurrence of a repeated information element must immediately follow the first occurrence of the repeated information element. The third occurrence of the repeated information element must immediately follow the second occurrence of the repeated information element, etc.
- If more than one information element of the same type is included in a message, and the repeated information elements do not immediately follow the preceding occurrence of this information element type, the receiving entity shall ignore subsequent information elements of this type.

14.3.1 Overview of B-BCC protocol messages

Table 20 summarizes the messages for the VB5.2 B-BCC protocol.

For each message the direction in which the message and the corresponding information elements may be sent is indicated.

Table 20: Messages for the B-BCC protocol

Procedure	Message	Direction		Reference
		SN to AN	AN to SN	
Bearer connection establishment	ALLOC	√		14.3.2.1
	ALLOC_ACC		√	14.3.2.2
	ALLOC_REJ		√	14.3.2.3
	ALLOC_COMP	√		14.3.2.4
	ALLOC_COMP_ACC		√	14.3.2.5
	ALLOC_COMP_REJ		√	14.3.2.6
Bearer connection release	DEALLOC	√		14.3.2.7
	DEALLOC_ACC		√	14.3.2.8
B-BCC reset	BBCC_RESET	√		14.3.3.1
	BBCC_RESET_ACC		√	14.3.3.2
	BBCC_RESET_REJ		√	14.3.3.3
B-BCC pre-synchronization as part of B-BCC restart	BBCC_PRESYNC	√		14.3.3.4
	BBCC_PRESYNC_ACC		√	14.3.3.5
	BBCC_PRESYNC_REJ		√	14.3.3.6
Reporting of error conditions	AN_FAULT		√	14.3.3.7
	AN_FAULT_ACC	√		14.3.3.8
	PROTOCOL_ERROR	√	√	14.3.3.9
Bearer connection modification	MODIFY	√		14.3.4.1
	MODIFY_ACC		√	14.3.4.2
	MODIFY_REJ		√	14.3.4.3
	MODIFY_COMP	√		14.3.4.4
	MODIFY_COMP_ACC		√	14.3.4.5
	MODIFY_COMP_REJ		√	14.3.4.6
	MODIFY_ABORT	√		14.3.4.7
	MODIFY_ABORT_ACC		√	14.3.4.8
	MODIFY_ABORT_REJ		√	14.3.4.9
Creation of a branch to a point-to- multipoint connection	ADD_BRANCH	√		14.3.5.1
	ADD_BRANCH_ACC		√	14.3.5.2
	ADD_BRANCH_REJ		√	14.3.5.3
	UPDATE_BRANCH	√		14.3.5.4
	UPDATE_BRANCH_ACC		√	14.3.5.5
	UPDATE_BRANCH_REJ		√	14.3.5.6
Deletion of a branch of a point-to- multipoint connection	DROP_BRANCH	√		14.3.5.7
	DROP_BRANCH_ACC		√	14.3.5.8
	DROP_BRANCH_REJ		√	14.3.5.9

Table 21: VB5.2 B-BCC protocol message type coding

Message type (octet 6)								bits	Reference
8	7	6	5	4	3	2	1		
0	1	x	x	x	x	x	x	VB5.2 B-BCC protocol message types	
		0	0	0	0	0	0	ALLOC	14.3.2.1
		0	0	0	0	0	1	ALLOC_ACC	14.3.2.2
		0	0	0	0	1	0	ALLOC_REJ	14.3.2.3
		0	0	0	0	1	1	ALLOC_COMP	14.3.2.4
		0	0	0	1	0	0	ALLOC_COMP_ACC	14.3.2.5
		0	0	0	1	0	1	ALLOC_COMP_REJ	14.3.2.6
		0	0	0	1	1	0	DEALLOC	14.3.2.7
		0	0	0	1	1	1	DEALLOC_ACC	14.3.2.8
		0	0	1	0	0	0	BBCC_RESET	14.3.3.1
		0	0	1	0	0	1	BBCC_RESET_ACC	14.3.3.2
		0	0	1	0	1	0	BBCC_RESET_REJ	14.3.3.3
		0	0	1	0	1	1	BBCC_PRESYNC	14.3.3.4
		0	0	1	1	0	0	BBCC_PRESYNC_ACC	14.3.3.5
		0	0	1	1	0	1	BBCC_PRESYNC_REJ	14.3.3.6
		0	0	1	1	1	0	AN_FAULT	14.3.3.7
		0	0	1	1	1	1	AN_FAULT_ACC	14.3.3.8
		0	1	0	0	0	0	PROTOCOL_ERROR	14.3.3.9
		0	1	0	0	0	1	MODIFY	14.3.4.1
		0	1	0	0	1	0	MODIFY_ACC	14.3.4.2
		0	1	0	0	1	1	MODIFY_REJ	14.3.4.3
		0	1	0	1	0	0	MODIFY_COMP	14.3.4.4
		0	1	0	1	0	1	MODIFY_COMP_ACC	14.3.4.5
		0	1	0	1	1	0	MODIFY_COMP_REJ	14.3.4.6
		0	1	0	1	1	1	MODIFY_ABORT	14.3.4.7
		0	1	1	0	0	0	MODIFY_ABORT_ACC	14.3.4.8
		0	1	1	0	0	1	MODIFY_ABORT_REJ	14.3.4.9
		0	1	1	0	1	0	ADD_BRANCH	14.3.5.1
		0	1	1	0	1	1	ADD_BRANCH_ACC	14.3.5.2
		0	1	1	1	0	0	ADD_BRANCH_REJ	14.3.5.3
		0	1	1	1	0	1	UPDATE_BRANCH	14.3.5.4
		0	1	1	1	1	0	UPDATE_BRANCH_ACC	14.3.5.5
		0	1	1	1	1	1	UPDATE_BRANCH_REJ	14.3.5.6
		1	0	0	0	0	0	DROP_BRANCH	14.3.5.7
		1	0	0	0	0	1	DROP_BRANCH_ACC	14.3.5.8
		1	0	0	0	1	0	DROP_BRANCH_REJ	14.3.5.9

All other values are reserved.

In the following subclauses the B-BCC message layout is defined.

Information elements included in a specific message can be sent to all directions in which the message is sent. A message or information element is stated as mandatory in this specification only when it is used in a specific direction only.

All VB5.2 B-BCC protocol messages comprise the common information as shown as an overview in table 22.

Table 22: Information commonly used in messages

Information Elements	Reference	Type	Length
Protocol discriminator	EN 301 005-1 [1] subclause 14.1.1 item a)	M	1
Transaction identifier	EN 301 005-1 [1] subclause 14.1.1 item b)	M	4
Message type	EN 301 005-1 [1] subclause 14.1.1 item c)	M	1
Message compatibility instruction indicator	EN 301 005-1 [1] subclause 14.1.1 item d)	M	1
Message length	EN 301 005-1 [1] subclause 14.1.1 item e)	M	2

14.3.2 B-BCC messages for the support of basic B-BCC procedures

This subclause defines the structure and contents of the B-BCC messages required for the support of the basic B-BCC procedures, i.e.:

- ALLOC message;
- ALLOC_COMP message;
- DEALLOC message;

and the corresponding acknowledgement messages.

14.3.2.1 ALLOC message

This message is used by the SN to request from the AN the allocation of a bearer connection represented by a VC link at a particular logical user port, a VC link at the logical service port and the VC interconnection between these VC links. The message is composed by the common message information given in table 22 and the information elements given in table 23.

Table 23: ALLOC message content

Information Elements	Reference	Type	Length
Connection reference number	14.3.6.2	M	7
ATM traffic descriptor	14.3.7.1	M	12 to 54
Broadband bearer capability	14.3.7.2	M	7 to 8
QoS parameters	14.3.7.4	M	6
User port connection identifier	14.3.6.4	M	8 to 12
Service port connection identifier	14.3.6.5	M	9
Alternative user port VPCI	14.3.6.6	O	6 (note 1)
Alternative service port VPCI	14.3.6.7	O	6 (note 1)
Branch identifier	14.3.6.10	O (note 2)	6
ABR set-up parameters	14.3.7.5	O (note 3)	4 to 32
End-to-End transit delay	14.3.7.6	O	4 to 10
CDVT parameter	14.3.7.7	O	4 to 22
OAM traffic descriptor	14.3.7.3	O	4 to 6
Alternative ATM traffic descriptor	14.3.7.8	O (note 4)	4 to 54
Minimum acceptable ATM traffic descriptor	14.3.7.9	O (note 4)	4 to 28
NOTE 1: The minimum length is 6 octets. The actual length depends on the number of VPCIs indicated in this information element.			
NOTE 2: Mandatory for point-to-multipoint connections.			
NOTE 3: Mandatory when the broadband transfer capability information element indicates "ABR".			
NOTE 4: Either the minimum acceptable ATM traffic descriptor information element or the alternative ATM traffic descriptor information element (but not both) may be included to support the negotiation of the connection characteristics.			

14.3.2.2 ALLOC_ACC message

This message is used by the AN to notify the SN that the allocation of the bearer connection requested by the SN has been accepted. The message is composed by the common message information given in table 22 and the information elements given in table 24.

Table 24: ALLOC_ACC message content

Information Elements	Reference	Type	Length
ATM traffic descriptor	14.3.7.1	O (note 1)	4 to 54
User port connection identifier	14.3.6.4	O (note 2)	12
Service port connection identifier	14.3.6.5	O (note 3)	9
Branch identifier	14.3.6.10	O (note 4)	6
ABR set-up parameters	14.3.7.5	O (note 5)	4 to 32
End-to-End transit delay	14.3.7.6	O (note 6)	4 to 10
CDVT parameter	14.3.7.7	O (note 6)	4 to 22
Alternative ATM traffic descriptor	14.3.7.8	O (note 7)	4 to 54
Minimum acceptable ATM traffic descriptor	14.3.7.9	O (note 7)	4 to 28
Automatic congestion level	14.3.6.8	O	5
NOTE 1: The inclusion of this information element depends on the result of the parameter negotiation in the AN (refer to subclause 13.5.4.3).			
NOTE 2: Mandatory when the AN has selected a user port VPCI/VCI combination other than the preferred one.			
NOTE 3: Mandatory when the AN has selected a service port VPCI/VCI combination other than the preferred one.			
NOTE 4: Mandatory for point-to-multipoint connections. If the AN is not able to establish a multicast tree, this information element shall not be included.			
NOTE 5: Mandatory when the broadband transfer capability information element in the ALLOC message has indicated "ABR".			
NOTE 6: Mandatory when this information element has been included in the ALLOC message.			
NOTE 7: To be completed.			

14.3.2.3 ALLOC_REJ message

This message is used by the AN to notify the SN that the allocation of the bearer connection requested by the SN has not been accepted. The message is composed by the common message information given in table 22 and the information elements given in table 25.

Table 25: ALLOC_REJ message content

Information Elements	Reference	Type	Length
Reject cause	14.3.6.9	M	5
Automatic congestion level	14.3.6.8	O	5

14.3.2.4 ALLOC_COMP message

This message is used by the SN to request from the AN to complete the allocation of the requested bearer connection. The message is composed by the common message information given in table 22 and the information elements given in table 26.

Table 26: ALLOC_COMP message content

Information Elements	Reference	Type	Length
Connection reference number	14.3.6.2	M	7
ATM traffic descriptor	14.3.7.1	O (note 1)	4 to 54
User port connection identifier	14.3.6.4	O (note 2)	12
ABR set-up parameters	14.3.7.5	O (note 3)	4 to 32
CDVT parameter	14.3.7.7	O (note 1)	4 to 22
NOTE 1: Mandatory when one or more traffic parameters have been changed.			
NOTE 2: Mandatory if the VPCI and/or VCI at the user port has not yet been selected during the allocation procedure.			
NOTE 3: Mandatory when the broadband transfer capability information element in the ALLOC message has indicated "ABR".			

14.3.2.5 ALLOC_COMP_ACC message

This message is used by the AN to notify the SN that the allocation of the requested bearer connection has been successfully completed. The message is composed by the common message information given in table 22.

14.3.2.6 ALLOC_COMP_REJ message

This message is used by the AN to notify the SN that the allocation of the requested bearer connection has not been successfully completed. The message is composed by the common message information given in table 22 and the information elements given in table 27.

Table 27: ALLOC_COMP_REJ message content

Information Elements	Reference	Type	Length
Reject cause	14.3.6.9	M	5

14.3.2.7 DEALLOC message

This message is used by the SN to request from the AN the deallocation of the bearer connection identified by the connection reference number which was assigned during the allocation procedure. The message is composed by the common message information given in table 22 and the information elements given in table 28.

Table 28: DEALLOC message content

Information Elements	Reference	Type	Length
Connection reference number list	14.3.6.3	M (note 1)	7 (note 2)
NOTE 1: The connection reference number information element may be present instead of the connection reference number list information element.			
NOTE 2: The minimum length is 7 octets. The actual length depends on the number of connection reference numbers indicated in this information element.			

14.3.2.8 DEALLOC_ACC

This message is used by the AN to notify the SN that the de-allocation of the bearer connection requested by the SN has been successfully completed. This response message is also generated in case that the connection reference number has not been allocated in the AN. The message is composed by the common message information given in table 22 and the information elements given in table 29.

Table 29: DEALLOC_ACC message content

Information Elements	Reference	Type	Length
Automatic congestion level	14.3.6.8	O	5

14.3.3 B-BCC messages for the support of B-BCC housekeeping procedures

This subclause defines the structure and contents of the B-BCC messages required for the support of the B-BCC housekeeping procedures, i.e.:

- BBCC_RESET message;
- BBCC_PRESYNC message;

and the corresponding acknowledgement messages. In addition, an AN_FAULT message and a PROTOCOL_ERROR message are defined to report certain error conditions.

14.3.3.1 BCC_RESET message

This message is used by the SN to request the AN to reset a specific resource to the idle condition. The message is composed by the common message information given in table 22 and the information elements given in table 30.

Table 30: BBCC_RESET message content

Information Elements	Reference	Type	Length
User port connection identifier	14.3.6.4	O (note)	8 to 12
Service port connection identifier	14.3.6.5	O (note)	5 to 9
NOTE: Either the user port connection identifier information element or the service port connection identifier information element is present.			

14.3.3.2 BBCC_RESET_ACC message

This message is used by the AN to notify the SN that the reset requested by the SN has been accepted. The message is composed by the common message information given in table 22.

14.3.3.3 BBCC_RESET_REJ message

This message is used by the AN to notify the SN that the reset requested by the SN has not been accepted. The message is composed by the common message information given in table 22 and the information elements given in table 31.

Table 31: BBCC_RESET_REJ message content

Information Elements	Reference	Type	Length
Reject cause	14.3.6.9	M	6 to 21

14.3.3.4 BBCC_PRESYNC message

This message is used by the SN to request from the AN the information whether the B-BCC function can resume its normal operation. The message is composed by the common message information given in table 22 and the information elements given in table 32.

If the user port connection identifier information element is present, it shall indicate "VPC at the LUP".

If the service port connection identifier information element is present, it shall indicate either "complete LSP" or "VPC at the LSP".

Table 32: BBCC_PRESYNC message content

Information Elements	Reference	Type	Length
User port connection identifier	14.3.6.4	O (note)	8 to 12
Service port connection identifier	14.3.6.5	O (note)	5 to 9
NOTE: Either the user port connection identifier information element or the service port connection identifier information element is present.			

14.3.3.5 BBCC_PRESYNC_ACC message

This message is used by the AN to notify the SN that the B-BCC function can assume its normal operation and a B-BCC reset is not necessary. The message is composed by the common message information given in table 22.

14.3.3.6 BBCC_PRESYNC_REJ message

This message is used by the AN to notify the SN that a B-BCC reset shall be initiated before the B-BCC function can resume its normal operation. The message is composed by the common message information given in table 22.

Table 33: BBCC_PRESYNC_REJ message content

Information Elements	Reference	Type	Length
Reject cause	14.3.6.9	M	5

14.3.3.7 AN_FAULT message

This message is used by the AN to notify the SN that a fault with respect to a bearer connection has been detected. The message is composed by the common message information given in table 22 and the information elements given in table 34.

If the user port connection identifier information element is present, it shall indicate "VCC at the LUP".

If the service port connection identifier information element is present, it shall indicate "VCC at the LSP".

Table 34: AN_FAULT message content

Information Elements	Reference	Type	Length
Connection reference number	14.3.6.2	O (note 1)	7
Branch identifier	14.3.6.10	O (note 2)	6
User port connection identifier	14.3.6.4	O (note 1)	12
Service port connection identifier	14.3.6.5	O (note 1)	9
NOTE 1: At least one of these information elements is present.			
NOTE 2: Mandatory, if the connection reference number is present and a particular branch of a point-to-multipoint connection shall be identified.			

14.3.3.8 AN_FAULT_ACC message

This message is used by the SN to notify the AN that the indication of an AN fault has been received. The message is composed by the common message information given in table 22.

14.3.3.9 PROTOCOL_ERROR message

This message is used by the AN or the SN to report protocol syntax error conditions. The message is composed by the common message information given in table 22 and the information elements given in table 35.

Table 35: PROTOCOL_ERROR message content

Information Elements	Reference	Type	Length
Protocol error cause	14.3.7.10	M	5 to 7

14.3.4 Additional B-BCC messages for the support of traffic parameter modification

This subclause defines the structure and contents of the additional messages required for the support of traffic parameter modification, i.e.:

- MODIFY message;
- MODIFY_COMP message;
- MODIFY_ABORT message;

and the corresponding acknowledgement messages.

14.3.4.1 MODIFY message

This message is used by the SN to request from the AN the modification of a bearer connection. The message is composed by the common message information given in table 22 and the information elements given in table 36.

Table 36: MODIFY message content

Information Elements	Reference	Type	Length
Connection reference number	14.3.6.2	M	7
ATM traffic descriptor	14.3.7.1	M	12 to 54
Alternative ATM traffic descriptor	14.3.7.8	O (note)	4 to 54
Minimum acceptable ATM traffic descriptor	14.3.7.9	O (note)	4 to 28
NOTE: Either the minimum acceptable ATM traffic descriptor information element or the alternative ATM traffic descriptor information element (but not both) is included to support the negotiation of the connection characteristics.			

14.3.4.2 MODIFY_ACC message

This message is used by the AN to notify the SN that the modify request has been accepted. The message is composed by the common message information given in table 22 and the information elements given in table 37.

Table 37: MODIFY_ACC message content

Information Elements	Reference	Type	Length
ATM traffic descriptor	14.3.7.1	O (note)	4 to 54
Alternative ATM traffic descriptor	14.3.7.8	O (note)	4 to 54
Minimum acceptable ATM traffic descriptor	14.3.7.9	O (note)	4 to 28
Automatic congestion level	14.3.6.8	O	5
NOTE: The inclusion of this information element depends on the result of the parameter negotiation in the AN (refer to subclause 13.5.4.3).			

14.3.4.3 MODIFY_REJ message

This message is used by the AN to notify the SN that the modify request has been rejected. The message is composed by the common message information given in table 22 and the information elements given in table 38.

Table 38: MODIFY_REJ message content

Information Elements	Reference	Type	Length
Reject cause	14.3.6.9	M	5
Automatic congestion level	14.3.6.8	O	5

14.3.4.4 MODIFY_COMP message

This message is used by the SN to request from the AN the update of traffic parameters of the requested bearer connection. The message is composed by the common message information given in table 22 and the information elements given in table 39.

Table 39: MODIFY_COMP message content

Information Elements	Reference	Type	Length
ATM traffic descriptor	14.3.7.1	O (note)	4 to 54
NOTE: Mandatory when one or more traffic parameters have been changed.			

14.3.4.5 MODIFY_COMP_ACC message

This message is used by the AN to notify the SN that the update of traffic parameters has been accepted. The message is composed by the common message information given in table 22.

14.3.4.6 MODIFY_COMP_REJ message

This message is used by the AN to notify the SN that the update of traffic parameters has been rejected. The message is composed by the common message information given in table 22 and the information elements given in table 40.

Table 40: MODIFY_COMP_REJ message content

Information Elements	Reference	Type	Length
Reject cause	14.3.6.9	M	5

14.3.4.7 MODIFY_ABORT message

This message is used by the SN to request from the AN the termination of a modification procedure. The message is composed by the common message information given in table 22 and the information elements given in table 41.

Table 41: MODIFY_ABORT message content

Information Elements	Reference	Type	Length
Connection reference number	14.3.6.2	M	7

14.3.4.8 MODIFY_ABORT_ACC message

This message is used by the AN to notify the SN that the termination of the modification procedure requested by the SN has been accepted. The message is composed by the common message information given in table 22.

14.3.4.9 MODIFY_ABORT_REJ message

This message is used by the AN to notify the SN that the termination of the modification procedure requested by the SN has been accepted. The message is composed by the common message information given in table 22 and the information elements given in table 42.

Table 42: MODIFY_ABORT_REJ message content

Information Elements	Reference	Type	Length
Reject cause	14.3.6.9	M	5

14.3.5 Additional B-BCC messages for the support of point-to-multipoint connections

This subclause defines the structure and contents of the additional messages required for the support of point-to-multipoint bearer connections, i.e.:

- ADD_BRANCH message;
- UPDATE_BRANCH message;
- DROP_BRANCH message;

and the corresponding acknowledgement messages.

14.3.5.1 ADD_BRANCH message

This message is used by the SN to request from the AN the addition of a subsequent branch to an existing point to multipoint connection which is identified by the "connection reference number". The message is composed of the common message information given in table 22 and the information elements given table 43.

Table 43: ADD_BRANCH message content

Information Elements	Reference	Type	Length
Connection reference number	14.3.6.2	M	7
Branch identifier	14.3.6.10	M	6
User port connection identifier	14.3.6.4	M	8 to 12
Alternative user port VPCI	14.3.6.6	O	6 (note)
NOTE: The minimum length is 6 octets. The actual length depends on the number of VPCIs indicated in this information element.			

14.3.5.2 ADD_BRANCH_ACC message

This message is used by the AN to notify the SN that a branch has been successfully added. The message is composed of the common message information given in table 22 and the information elements given table 44.

Table 44: ADD_BRANCH_ACC message content

Information Elements	Reference	Type	Length
User port connection identifier	14.3.6.4	O (note)	12
Automatic congestion level	14.3.6.8	O	5
NOTE: Mandatory when the AN has selected a user port VPCI/VCI combination other than the preferred one.			

14.3.5.3 ADD_BRANCH_REJ message

This message is used by the AN to notify the SN that a branch has not been added. The message is composed of the common message information given in table 22 and the information elements given table 45.

Table 45: ADD_BRANCH_REJ message content

Information Elements	Reference	Type	Length
Reject cause	14.3.6.9	M	5
Automatic congestion level	14.3.6.8	O	5

14.3.5.4 UPDATE_BRANCH message

This message is used by the SN to request the AN to update the bearer connection characteristics of a specified branch. The message is composed of the common message information given in table 22 and the information elements given table 46.

Table 46: UPDATE_BRANCH message content

Information Elements	Reference	Type	Length
Connection reference number	14.3.6.2	M	7
Branch identifier	14.3.6.10	M	6
User port connection identifier	14.3.6.4	M	12

14.3.5.5 UPDATE_BRANCH_ACC message

This message is used by the AN to notify the SN that the bearer connection characteristics of the specified branch have been successfully updated. The message is composed of the common message information given in table 22.

14.3.5.6 UPDATE_BRANCH_REJ message

This message is used by the AN to notify the SN that the bearer connection characteristics of the specified branch have not been updated. The message is composed of the common message information given in table 22 and the information elements given table 47.

Table 47: UPDATE_BRANCH_REJ message content

Information Elements	Reference	Type	Length
Reject cause	14.3.6.9	M	5

14.3.5.7 DROP_BRANCH message

This message is used by the SN to request the AN to delete the specified branch of a point to multipoint connection. The message is composed of the common message information given in table 22 and the information elements given table 48.

Table 48: DROP_BRANCH message content

Information Elements	Reference	Type	Length
Connection reference number	14.3.6.2	M	7
Branch identifier list	14.3.6.11	M (note 1)	6 (note 2)
NOTE 1: The branch identifier information element may be present instead of the branch identifier list information element.			
NOTE 2: The minimum length is 6 octets. The actual length depends on the number of branch identifiers indicated in this information element.			

14.3.5.8 DROP_BRANCH_ACC message

This message is used by the AN to notify the SN that the specified branch has been successfully deleted. The message is composed of the common message information given in table 22 and the information elements given table 49.

Table 49: DROP_BRANCH_ACC message content

Information Elements	Reference	Type	Length
Automatic congestion level	14.3.6.8	O	5

14.3.5.9 DROP_BRANCH_REJ message

This message is used by the AN to notify the SN that a branch has not been deleted. The message is composed of the common message information given in table 22 and the information elements given table 50.

Table 50: DROP_BRANCH_REJ message content

Information Elements	Reference	Type	Length
Reject cause	14.3.6.9	M	5
Automatic congestion level	14.3.6.8	O	5

14.3.6 B-BCC function specific information elements

14.3.6.1 Overview

Table 51 summarizes the information elements which are specific for the VB5.2 B-BCC protocol.

Table 51: VB5.2 B-BCC protocol information elements

Information Element	Reference	Length
Connection reference number	14.3.6.2	7
Connection reference number list	14.3.6.3	7 (minimum)
User port connection identifier	14.3.6.4	8 to 12
Service port connection identifier	14.3.6.5	5 to 9
Alternative user port VPCI	14.3.6.6	6 (minimum)
Alternative service port VPCI	14.3.6.7	6 (minimum)
Automatic congestion level	14.3.6.8	5
Reject cause	14.3.6.9	5
Branch identifier	14.3.6.10	6
Branch identifier list	14.3.6.11	6 (minimum)
ATM traffic descriptor	14.3.7.1	4 to 54
Broadband bearer capability	14.3.7.2	7 to 8
OAM traffic descriptor	14.3.7.3	4 to 6
QoS parameter	14.3.7.4	6
ABR setup parameter	14.3.7.5	4 to 32
End-to-end transit delay	14.3.7.6	4 to 10
CDVT parameter	14.3.7.7	4 to 22
Alternative ATM traffic descriptor	14.3.7.8	4 to 54
Minimum acceptable ATM traffic descriptor	14.3.7.9	4 to 28
Protocol error cause	14.3.7.10	5 to 7

All B-BCC function specific information elements are composed by the common information as specified in EN 301 005-1 [1], subclause 14.1.2, and shown as an overview in table 52.

Table 52: Information commonly used in information elements

Information Elements	Reference	Length
Information element type	Table 53 and EN 301 005-1 [1], subclause 14.1.2 item a)	1
Information element compatibility instruction indicator	EN 301 005-1 [1] subclause 14.1.2 item b)	1
Information element length	EN 301 005-1 [1] subclause 14.1.2 item c)	2

The encoding for the information element type is given in table 53. The encoding for the information element compatibility instruction indicator and the information element length are defined in subclause 14.1.2 of EN 301 005-1 [1].

Table 53: VB5.2 B-BCC protocol information element type coding

Information element type (octet N + 1)									bits	Reference
8	7	6	5	4	3	2	1			
0	0	0	0	0	0	0	0	0	Connection reference number	14.3.6.2
0	0	0	0	0	0	0	0	1	Connection reference number list	14.3.6.3
0	0	0	0	0	0	0	1	0	User port connection identifier	14.3.6.4
0	0	0	0	0	0	0	1	1	Service port connection identifier	14.3.6.5
0	0	0	0	0	0	1	0	0	Alternative user port VPCI	14.3.6.6
0	0	0	0	0	0	1	0	1	Alternative service port VPCI	14.3.6.7
0	0	0	0	0	0	1	1	0	Automatic congestion level	14.3.6.8
0	0	0	0	0	0	1	1	1	Reject cause	14.3.6.9
0	0	0	0	1	0	0	0	0	Branch identifier	14.3.6.10
0	0	0	0	1	0	0	0	1	Branch identifier list	14.3.6.11
0	0	0	0	1	0	1	0	0	ATM traffic descriptor	14.3.7.1
0	0	0	0	1	0	1	1	1	Broadband bearer capability	14.3.7.2
0	0	0	0	0	1	1	0	0	OAM traffic descriptor	14.3.7.3
0	0	0	0	0	1	1	0	1	Quality of Service parameters	14.3.7.4
0	0	0	0	1	1	1	1	0	ABR set-up parameter	14.3.7.5
0	0	0	0	1	1	1	1	1	End-to-End transit delay	14.3.7.6
0	0	0	1	0	0	0	0	0	CDVT parameters	14.3.7.7
0	0	0	1	0	0	0	0	1	Alternative ATM traffic descriptor	14.3.7.8
0	0	0	1	0	0	1	0	0	Minimum acceptable ATM traffic descriptor	14.3.7.9
0	0	0	1	0	0	1	1	1	Protocol error cause	14.3.7.10
All other values are reserved.										

14.3.6.2 Connection reference number

The purpose of the connection reference number information element is to identify the bearer connection to which a particular B-BCC message applies. The connection reference number information element is composed of the common octets given in table 52 and the octets shown in figure 33. The length of this information element is 7 octets.

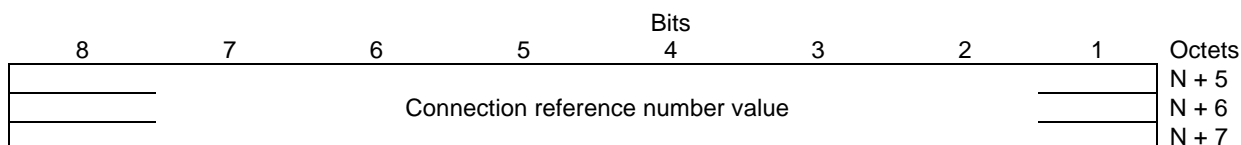
**Figure 33: Connection reference number information element coding**

14.3.6.3 Connection reference number list

The purpose of the connection reference number list information element is to identify the set of bearer connection to which a particular B-BCC message applies. The connection reference number list information element is composed of the common octets given in table 52 and repeated octets as defined in figure 33 for the connection reference number value. However, the length of the message where this information element is used shall not exceed the maximum message length.

14.3.6.4 User port connection identifier

The purpose of the user port connection identifier information element is to identify the connection resource at the logical user port.

The user port connection identifier information element is composed of the common octets given in table 52 and the octets shown in figure 34 and table 54. The length of this information element is in the range of 8 to 12 octets.

Bits				Octet				
8	7	6	5	4	3	2	1	
ext. "1"B		Resource indicator		direction flag		connection identifier flag		N + 5
		Logical user port identifier						N + 6
								N + 7
								N + 8
		VPCI (note 1)						N + 9*
								N + 10*
		VCI (note 2)						N + 11*
								N + 12*

NOTE 1: This field is present if the resource indicator indicates either "VPC at the LUP" or "VCC at the LUP". In all other cases this field is absent.

NOTE 2: This field is present if the resource indicator indicates "VCC at the LUP". In all other cases this field is absent.

Figure 34: User port connection identifier information element coding

Table 54: User port connection identifier information element values

Resource indicator (octet N + 5)			
7	6	5	bits
0	0	0	Complete LUP. Neither the VPCI field nor the VCI field shall be present.
0	0	1	VPC at the LUP. The VPCI field shall be present.
0	1	0	VCC at the LUP. The VPCI field and the VCI field shall be present.
All other values are reserved.			
Direction flag (octet N + 5) (note 1)			
4	3	bits	
0	0	user port represents the originating side of the bearer connection	
0	1	user port represents the terminating side of the bearer connection	
Connection identifier flag (octet N + 5) (note 2)			
2	1	bits	
0	0	exclusive VPCI/VCI combination	
0	1	preferred VPCI/VCI combination	
All other values are reserved.			
Logical user port identifier (octets N + 6 to N + 8)			
The logical user port identifier value identifies a logical user port (LUP). For the use of logical user port identifier see subclause 7.3.3 "Connection element identifiers in B-BCC messages". The numeric value is in the range of 0 through 16 777 215 and shall be coded as a binary 24 bit value.			
VPCI (octets N + 9 and N + 10)			
The VPCI value(s) identifies a virtual path connection. For the use of VPCIs see subclause 7.3. "Connection element identifiers in B-BCC messages". The numeric value is in the range of 0 through 65 535 and shall be coded as a binary 16 bit value.			
VCI (octets N + 11 and N + 12)			
The VCI value(s) identifies a virtual channel link. For the use of VCIs see subclause 7.3.3 "Connection element identifiers in B-BCC messages". The numeric value is in the range of 0 through 65 535 and shall be coded as a binary 16 bit value. According to ITU-T Recommendation I.361 [43]/ETS 300 298-2 [3], values in the range from 0 through 31 are not available for user plane traffic.			
NOTE 1: This field shall be used in the ALLOC message. In all other messages it shall be ignored.			
NOTE 2: This field shall be used in the ALLOC and ADD_BRANCH message, if the resource indicator indicates "VCC at the LUP". In all other cases and all other messages, it shall be ignored.			

14.3.6.5 Service port connection identifier

The purpose of the service port connection identifier information element is to identify the connection resource at the logical service port.

The service port connection identifier information element is composed of the common octets given in table 52 and the octets shown in figure 35 and table 55. The length of this information element is in the range of 5 to 9 octets.

Bits					Octet			
8	7	6	5	4	3	2	1	
ext. "1"B	Resource indicator			Spare "0"B "0"B		connection identifier flag		N + 5
VPCI (note 1)								N + 6*
VCI (note 2)								N + 7*
								N + 8*
								N + 9*

NOTE 1: This field is present if the resource indicator indicates either "VPC at the LSP" or "VCC at the LSP". In all other cases this field is absent.

NOTE 2: This field is present if the resource indicator indicates "VCC at the LSP". In all other cases this field is absent.

Figure 35: Service port connection identifier information element coding

Table 55: Service port connection identifier information element values

Resource indicator (octet N + 5)			
7	6	5	bits
0	0	0	Complete LSP. Neither the VPCI field nor the VCI field shall be present.
0	0	1	VPC at the LSP. The VPCI field shall be present.
0	1	0	VCC at the LSP. The VPCI field and the VCI field shall be present.
All other values are reserved.			
Connection identifier flag (octet N + 5)			
(note)			
2	1	bits	
0	0	exclusive VPCI/VCI combination	
0	1	preferred VPCI/VCI combination	
All other values are reserved.			
VPCI (octets N + 9 and N + 10)			
The VPCI value(s) identifies a virtual path connection. For the use of VPCIs see subclause 7.3. "Connection element identifiers in B-BCC messages".			
The numeric value is in the range of 0 through 65 535 and shall be coded as a binary 16 bit value.			
VCI (octets N + 11 and N + 12)			
The VCI value(s) identifies a virtual channel link. For the use of VCIs see subclause 7.3.3 "Connection element identifiers in B-BCC messages".			
The numeric value is in the range of 0 through 65 535 and shall be coded as a binary 16 bit value.			
According to ITU-T Recommendation I.361 [43] / ETS 300 298-2 [3], values in the range from 0 through 31 are not available for user plane traffic.			
NOTE: This field shall be used in the ALLOC message. In all other messages, it shall be ignored.			

14.3.6.6 Alternative user port VPCI

The purpose of the alternative user port VPCI information element is to indicate alternative VPCIs which are available for the establishment of a VC link at the user port.

The alternative user port VPCI information element is composed of the common octets given in table 52 and the octets shown in figure 36.

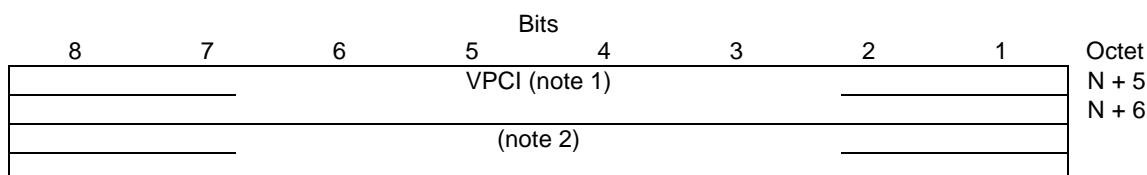

NOTE 1: The coding of the VPCI field is defined in table 54.

NOTE 2: The VPCI field may be repeated several times to indicate a set of VPCIs. However, the length of the message where this information element is used shall not exceed the maximum message length.

Figure 36: Alternative user port VPCI information element coding

14.3.6.7 Alternative service port VPCI

The purpose of the alternative service port VPCI information element is to indicate alternative VPCIs which are available for the establishment of a VC link at the service port.

The alternative service port VPCI information element has the same format and coding as the alternative user port VPCI information element, except for the coding of the information element type.

14.3.6.8 Automatic congestion level

The automatic congestion level information element indicates that a particular level of congestion has been exceeded at the sending access network. The automatic congestion level information element is composed of the common octets given in table 52 and the octets shown in figure 37 and table 56. The length of this information element is 5 octets.

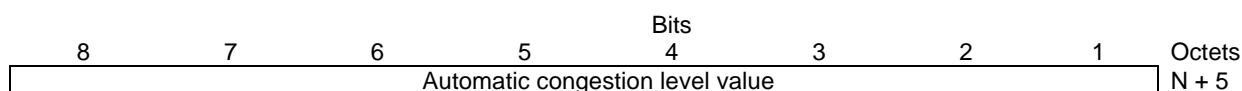

Figure 37: Automatic congestion level information element coding

Table 56: Automatic congestion level values

Automatic congestion level value (octet 5)								
8	7	6	5	4	3	2	1	bits
0	0	0	0	0	0	0	1	Congestion level 1 exceeded
0	0	0	0	0	0	1	0	Congestion level 2 exceeded
All other values are reserved.								

14.3.6.9 Reject cause

The purpose of the reject cause information element is to provide information on the reason why an action requested by the SN has not been completed.

The reject cause information element is composed of the common octets given in table 52 and the octets shown in figure 38 and table 57. The length of this information element is 5 octets.

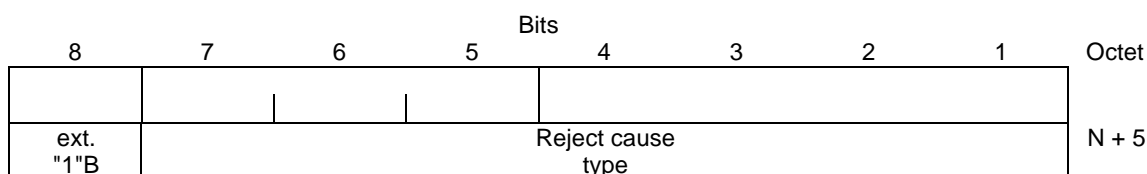

Figure 38: Reject cause information element coding

Table 57: Reject cause type values

Reject cause type (octet 5)							
7	6	5	4	3	2	1	bits
0	0	0	0	0	0	0	Unspecified error
0	0	0	0	0	0	1	Message not compatible with connection state
0	0	0	0	0	1	0	Message not compatible with branch state
0	0	0	0	0	1	1	Deallocation of last branch expected
0	0	0	0	0	1	0	Access network fault
0	0	0	0	1	0	1	Insufficient AN resources (note)
0	0	0	0	1	1	0	Insufficient resources at user port (note)
0	0	0	0	1	1	1	Insufficient resources at service port (note)
0	0	0	1	0	0	0	Combination of traffic parameters not supported
0	0	0	1	0	0	1	ATM transfer capability not supported
0	0	0	1	0	1	0	User port connection identifier already in use
0	0	0	1	0	1	1	Service port connection identifier already in use
0	0	0	1	1	0	0	Invalid LUP-ID
0	0	0	1	1	0	1	Invalid user port VPCI
0	0	0	1	1	1	0	Invalid user port VCI
0	0	0	1	1	1	1	Invalid service port VPCI
0	0	1	0	0	0	0	Invalid service port VCI

All other values are reserved.

NOTE: Examples for the use of this reject cause are: (a) insufficient resources with respect to the transfer functions (e.g. due to bandwidth limitations); (b) insufficient resources with respect to the connection control functions (e.g. due to the number of connection requests which can be handled simultaneously).

14.3.6.10 Branch identifier

The purpose of the branch identifier information element is to uniquely identify a branch that is associated with a point-to-multipoint connection. The branch identity is unique per connection reference number.

The branch identifier information element is composed of the common octets given in table 52 and the octets shown in figure 39. The length of this information element is 6 octets.

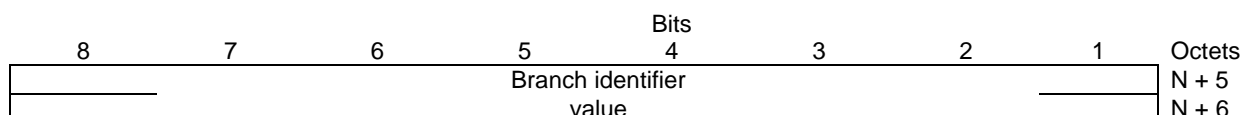

Figure 39: Branch identifier information element coding

14.3.6.11 Branch identifier list

The purpose of the branch identifier list information element is to uniquely identify a set of branches that is associated with a point-to-multipoint connection. The list of branch identifiers is unique per connection reference.

The branch identifier list information element is composed of the common information elements given in table 52 and repeated octets as defined in figure 39 for the branch identifier value. However, the length of the message where this information element is used shall not exceed the maximum message length.

14.3.7 B-BCC function information elements based on other Recommendations

The coding of the specific content of the B-BCC specific information elements specified in this subclause is equivalent to the coding used in other Recommendations.

However, the common octets (i.e. octets N+1 to N+4) of these information elements are coded as given in table 52. The references to other Recommendations exclusively apply to the coding of the information element specific content in octet N+5 and subsequent octets.

14.3.7.1 ATM traffic descriptor

The purpose of the ATM traffic descriptor information element is to specify the traffic parameter set that defines the traffic characteristics of the bearer connection. The ATM traffic descriptor information element shall be coded as specified in the following Recommendations:

- subclause 4.5.6 / ITU-T Recommendation Q.2931 [28];
- subclause 8.2.1 / ITU-T Recommendation Q.2961 [29] (for extensions);
- subclause 3.8.2.1 / ITU-T Recommendation Q.2961.3 [31] (for extensions);
- subclause 8.2.1 / ITU-T Recommendation Q.2961.4 [32] (for extensions).

14.3.7.2 Broadband bearer capability

The purpose of the broadband bearer capability information element is to indicate the required broadband connection oriented bearer service to be provided by the network. The broadband bearer capability information element shall be coded as specified in the following Recommendations:

- subclause 4.5.7 / ITU-T Recommendation Q.2931 [28];
- subclause 2.6.1 / ITU-T Recommendation Q.2961.2 [30];
- subclause 3.8.2.3 / ITU-T Recommendation Q.2961.3 [31] (for extensions);
- subclause 8.2.2 / ITU-T Recommendation Q.2961.4 [32] (for extensions).
- subclause 6.8.2.2 / ITU-T Recommendation Q.2961.6 [34] (for extensions).

There is no default in the broadband bearer capability.

It is the task of the SN to take care of the backward compatibility with the coding defined in ITU-T Recommendation Q.2931 [28]. Therefore the B-BCC does not support any coding for backward compatibility.

14.3.7.3 OAM traffic descriptor

The purpose of the OAM traffic descriptor information element is to provide information regarding the end-to-end OAM F5 information flow for performance management pertaining to a user connection included in the descriptor and fault management generated by a user.

The OAM traffic descriptor information element shall be coded as specified in subclause 4.5.24 / ITU-T Recommendation Q.2931 [28].

Refer to annex I / ITU-T Recommendation Q.2931 [28] for the processing of the OAM traffic descriptor information element.

14.3.7.4 QoS parameter

The purpose of the QoS parameter information element is to indicate a QoS class.

The QoS parameter information element shall be coded as specified in subclause 4.5.18 / ITU-T Recommendation Q.2931 [28].

14.3.7.5 ABR set-up parameters

The purpose of the ABR set-up parameters information element is to specify the set of ABR parameters during call/connection establishment. The ABR set-up parameters information element shall be coded as specified in subclause 8.2.2/ITU-T Recommendation Q.2961.3 [31].

14.3.7.6 End-to-End transit delay

The purpose of the end-to-end transit delay information element is to indicate the normal maximum end-to-end transit delay acceptable on a per call basis, and to indicate the cumulative transit delay to be expected for a bearer channel connection. The end-to-end transit delay information element shall be coded as specified in subclause 4.5.17/ITU-T Recommendation Q.2931 [28].

14.3.7.7 Cell delay variation tolerance (CDVT)

The purpose of the CDVT parameters information element is to support per-call CDVT value. The CDVT parameters information element shall be coded as specified in subclause 4.5.17/ITU-T Recommendation Q.2961.5 [33].

14.3.7.8 Alternative ATM traffic descriptor

The purpose of the alternative ATM traffic descriptor information element is to specify an alternative ATM traffic descriptor for the negotiation of traffic parameters during call/connection establishment.

The alternative ATM traffic descriptor information element shall be coded as specified in subclause 8.2.1/ITU-T Recommendation Q.2962 [35].

14.3.7.9 Minimum acceptable ATM traffic descriptor

The purpose of the minimum acceptable ATM traffic descriptor information element is to specify the minimum acceptable ATM traffic parameters in the negotiation of traffic parameters during call/connection set-up. The minimum acceptable ATM traffic parameters are the lowest values that the user is willing to accept for the call/connection.

The minimum acceptable ATM traffic descriptor information element shall be coded as specified in the following Recommendations:

- subclause 8.2.2/ITU-T Recommendation Q.2962 [35];
- subclause 3.8.2.4/ITU-T Recommendation Q.2961.3 [31] (for extensions);
- subclause 8.2.3/ITU-T Recommendation Q.2961.4 [32] (for extensions).

14.3.7.10 Protocol error cause

The protocol error cause information element provides the cause of a protocol syntax error.

The protocol error cause information element shall be coded as specified in EN 301 005-1 [1].

Annex A (normative): SDL process diagrams

This annex contains the SDL process diagrams for the B-BCC system.

The following versions are contained in archive b9o90ico.LZH which accompanies the present document:

- vb52cif.zip (contains CIF files);
- vb52sdl.zip (contains an Adobe Portable Document Format™ file);
- vb52pr.zip (contains SDL-PR file).

In addition a file vb52msc.zip is provided which contains example message sequence charts (as PostScript files compressed by WinZIP).

Further details are provided in a Readme.txt file contained in the vb52msc.ZIP.

Annex B (normative): Support of terminal equipment using the ATM Forum ATM UNI signalling version 4.0

B.1 Introduction

The B-BCC protocol specified in the main body of this specification is compatible with ETSI standards and ITU-T Recommendations. However, the ATM Forum ATM UNI signalling version 4.0 and ATM Forum traffic management specification version 4.0 support connection and traffic management capabilities which are not supported by the corresponding ETSI standards and ITU-T Recommendations.

This annex describes these capabilities as well as the impact of supporting them via the VB5.2 reference point (in particular the B-BCC protocol).

Although the annex describes the support of ATM-F UNI v4.0 signalling, it does not preclude the possibility of interworking with other UNI protocols (e.g. ATM-F UNI v3.1).

B.2 Principle differences

The clause describes the principle differences between the ATM Forum and ETSI / ITU-T connection and traffic management characteristics.

The ATM Forum supports the following capabilities which are not supported by ETSI / ITU-T:

- support of the UBR service class and frame discard service;
- additional quality of service parameters;
- additional ATM transfer capabilities;
- additional ABR service parameters.

The ITU-T supports the following capabilities which are not supported by the ATM Forum:

- modification of traffic parameters of established connections;
- support of ABT (ITU-T Recommendation Q.2961.4);
- support of SBR2 and SBR3 (ITU-T Recommendation Q.2961.6).

The ATM-F additional capabilities covered above are fully described in the ATM Forum ATM UNI signalling, version 4.0 specification and ATM Forum traffic management specification, version 4.0.

B.3 Protocol differences

A summary of ATM Forum ATM UNI signalling, version 4.0 differences from the corresponding ETSI standards / ITU T Recommendations are detailed below. In addition, the method for accommodating these differences is specified.

The following information elements are already supported by the B-BCC messages defined in clause 14, but additions are required for supporting terminal equipment using ATM-F UNI version 4.0:

- ATM Traffic Descriptor IE: has additional fields Forward/Backward Frame Discard (Octet 17.1), Best Effort Indicator (Octet 18). The ATM traffic descriptor IE defined in subclause 14.3.7.1 shall be extended to support both these additional subfields.

- Alternative ATM Traffic Descriptor IE: has additional fields Forward/Backward Frame Discard (Octet 17.1), Best Effort Indicator (Octet 18). The Alternative ATM traffic descriptor IE defined in subclause 14.3.7.8 shall be extended to support both these additional subfields.

The following new information elements which are not supported by the B-BCC messages specified in clause 14 are defined for supporting terminal equipment using ATM-F UNI version 4.0:

- Extended QoS Parameters IE: The purpose of this new information element is to indicate the individual QoS parameter values acceptable on a per connection basis and to indicate the cumulative QoS parameter values. The QoS parameter values included in the Extended QoS Parameters information element together with those included in the End-to-end Transit Delay information element (if present) specify a QoS capability at a UNI 4.0 interface.
- ABR Additional Parameters IE: The purpose of this new information element is to specify the set of additional ABR parameters during connection establishment.

The following information elements are already supported by the B-BCC messages defined in clause 14 and no new additions are required for terminal equipment using ATM-F UNI version 4.0:

- QoS Parameter IE: The extensions for this information element contained in ATM-F UNI version 4.0 support the signalling of additional quality of service classes. Only QoS class 0 shall be supported and the support of the other QoS classes is for further study.
- End-to-End Transit Delay IE: The ATM-F IE has an additional subfield 'Network generated indicator', which is used for specifying the origin of this IE. This additional subfield has no relevance for the B-BCC protocol.
- Broadband Bearer Capability IE: The ATM-F bearer class 'Transparent VP Service' is not currently supported by the VB5.2 reference point and is for further study.

The following information elements are not supported by ATM-F UNI version 4.0:

- OAM Traffic Descriptor IE: Since this is defined as an optional IE in the B-BCC messages specified in clause 14, then it may not be included for support of terminal equipment using ATM-F UNI version 4.0.
- Cell Delay Variation Tolerance (CDVT) IE: Since this is defined as an optional IE in the B-BCC messages specified in clause 14, then it may not be included for support of terminal equipment using ATM-F UNI version 4.0.

B.4 Connection control procedures

The connection control functions described in subclause 13.5.2 also apply when the B-BCC protocol is triggered by the call control co-ordination function according to an external event from an equipment using the ATM-F UNI version 4.0.

B.5 Extensions to B-BCC message format and codes

This clause describes the extensions to the B-BCC message format and codes for support of the additional ATM-F connection and traffic management capabilities.

B.5.1 ALLOC message

The following additions are required to table 24.

Table B.1

Information Elements	Reference	Type	Length
Extended QoS parameters	B.5.4.2	O (note)	4 to 25
ABR Additional Parameters	B.5.4.3	O	4 to 14
NOTE: The Extended QoS parameter and the QoS parameter are mutually exclusive.			

B.5.2 ALLOC_ACC message

The following additions are required to table 25.

Table B.2

Information Elements	Reference	Type	Length
ABR Additional Parameters	B.5.4.3	O	4 to 14

B.5.3 ALLOC_COMP message

The following additions are required to table 27.

Table B.3

Information Elements	Reference	Type	Length
ABR Additional Parameters	B.5.4.3	O	4 to 14

B.5.4 Additional B-BCC information element

B.5.4.1 Information element type coding

Table B.4: Extended VB5.2 B-BCC protocol information element type coding

Information element type (octet N + 1)									bits	Reference
8	7	6	5	4	3	2	1			
0	0	0	1	0	1	0	1	Extended QoS Parameters	B.5.4.2	
0	0	0	1	0	1	1	0	ABR Additional Parameters	B.5.4.3	

B.5.4.2 Extended QoS Parameters

The purpose of Extended QoS Parameters information element is to indicate the individual QoS parameter values acceptable on a per connection basis and to indicate the cumulative QoS parameter values. The QoS parameter values included in the Extended QoS Parameters information element together with those included in the End-to-end Transit Delay information element (if present) specify a QoS capability at a UNI 4.0 interface.

The Extended QoS Parameters information element is coded as defined in ATM-F UNI v4.0.

B.5.4.3 ABR Additional Parameters

The purpose of the ABR Additional Parameters information element is to specify the set of additional ABR parameters during connection establishment.

The ABR Additional Parameters information element is coded as defined in ATM-F UNI v4.0.

Annex C (informative): Interworking between B-BCC and DSS2

This annex describes the scenario where subscribers are connected to the SN via the AN using the DSS2 protocol. A co-ordination in the SN between the B-BCC protocol specified in this Recommendation and the DSS2 as specified in the relevant ITU-T Recommendations is necessary. Clause C.1 describes the message interworking between DSS2, B-ISUP and VB5.2. Clause C.2 explains the use of DSS2 information elements in VB5.2.

C.1 Message interworking

In B-ISDN there is an interworking relationship between DSS2 and the B-ISDN User Part of Signalling System No. 7. The interworking is described in ITU-T Recommendation Q.2650 [58]. This interworking typically occurs in the local exchange. In case that the local exchange supports an VB5.2 AN, a relationship between DSS2, B-ISUP and VB5 exists. The interworking is limited to the handling of a bearer connection, i.e., supplementary services and 64 kbit/s narrowband emulation are of no relevance for the B-BCC. Figure C.1 shows the basic relationship between the involved signalling protocols and Call Control. Call Control includes DSS2 application function, B-ISUP application function, VB5 B-BCC application function.

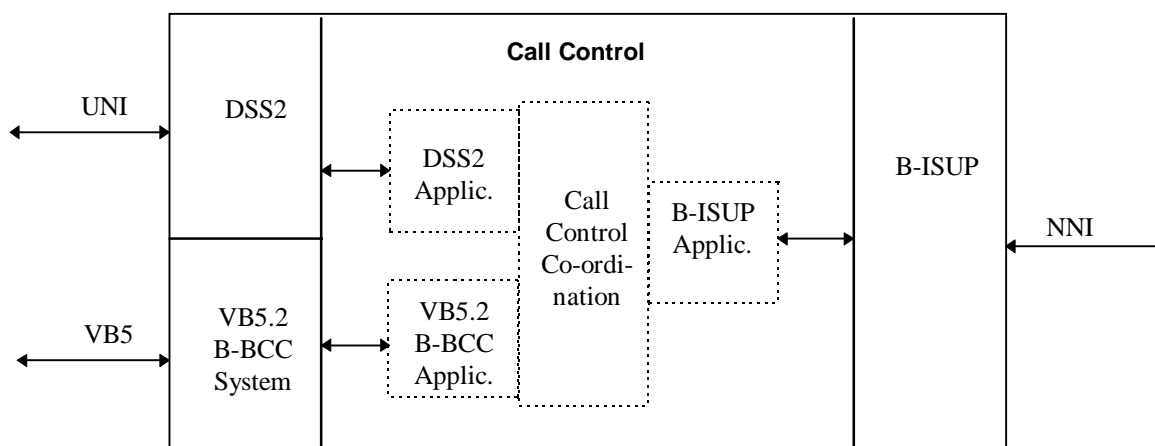

Figure C.1: Interworking model for the SN

There is no direct relationship between B-ISUP and VB5.2. The normal interworking between DSS2 and B-ISUP is untouched with the introduction of VB5.2. VB5.2 is always triggered by Call control co-ordination when the user side connection handling is done.

The following message sequence charts show the message interworking between DSS2, B-ISUP and VB5.2 for the set up, modification and release of a pt. to pt. and a pt. to mpt. bearer connection. The diagrams are examples and do not show all possible cases. Only the DSS2/B-ISUP messages relevant in the context with VB5 are shown.

C.1.1 Establishment of point-to-point connections

C.1.1.1 Connection establishment at the originating AN

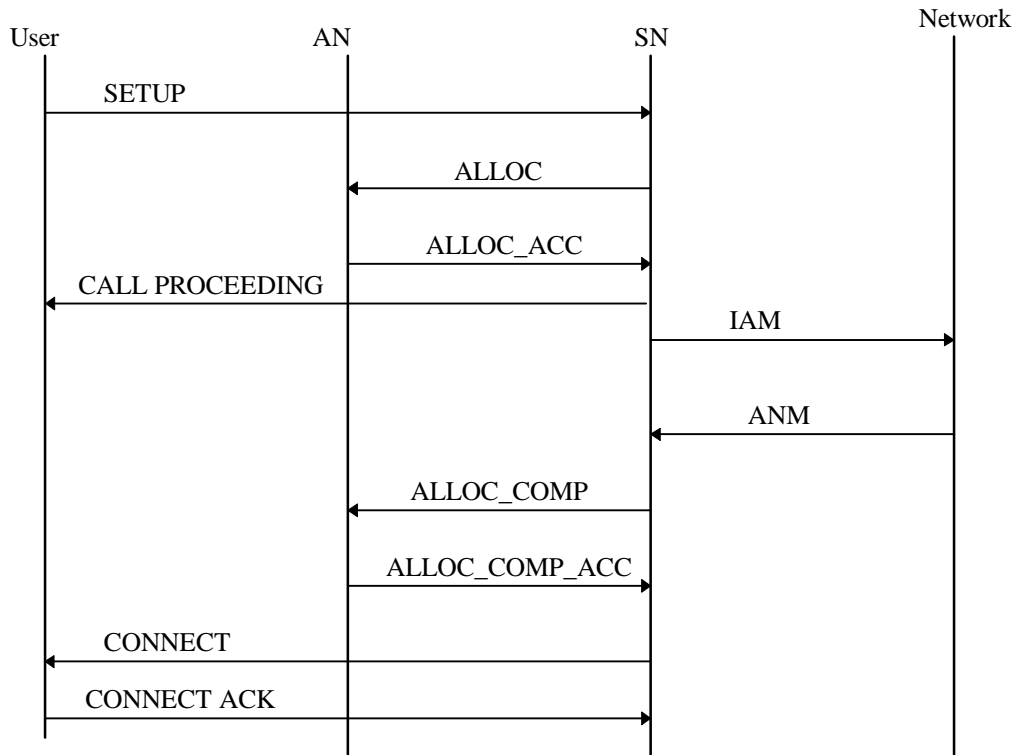
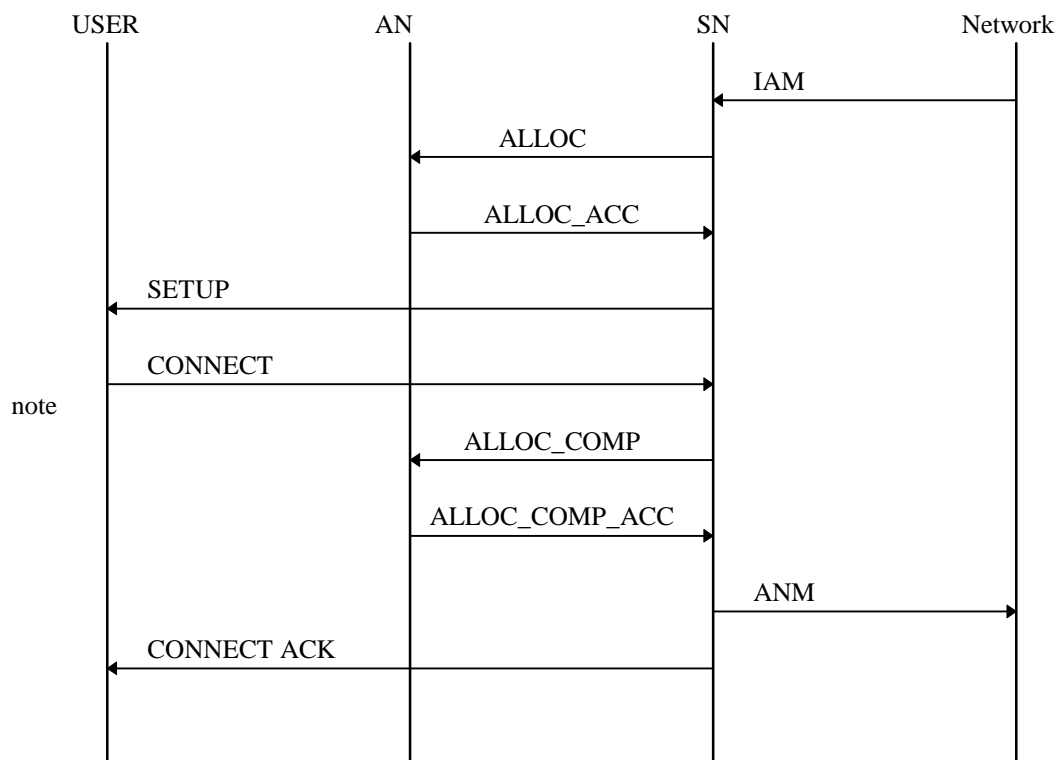

Figure C.2: Connection establishment (originating AN, successful)

C.1.1.2 Connection establishment at the terminating AN



NOTE: The user may respond to the SET UP message with a CALL PROCEEDING and/or ALERTING message which are not shown in the diagram. These messages may contain a Connection Identifier information element. This information is used by the ALLOC_COMP message, which is always triggered by the CONNECT message.

Figure C.3: Connection establishment (terminating AN, successful)

C.1.1.3 Unsuccessful connection establishment

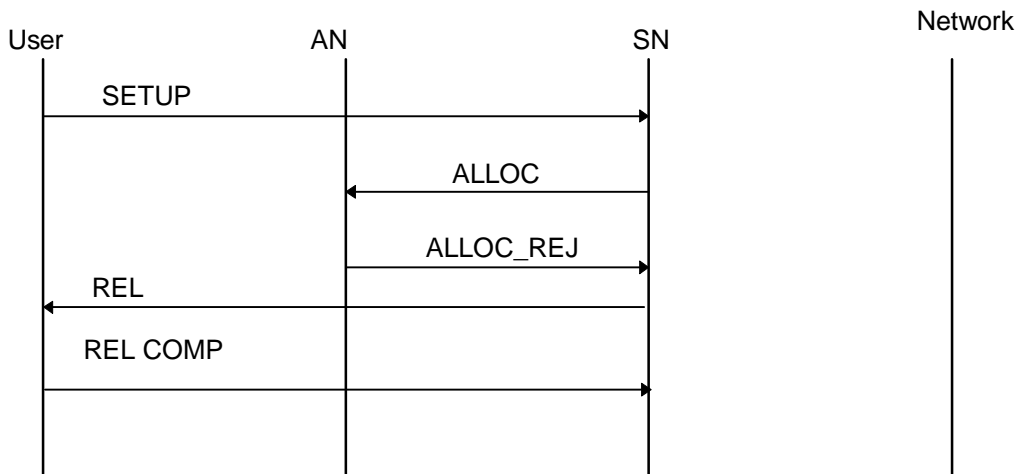
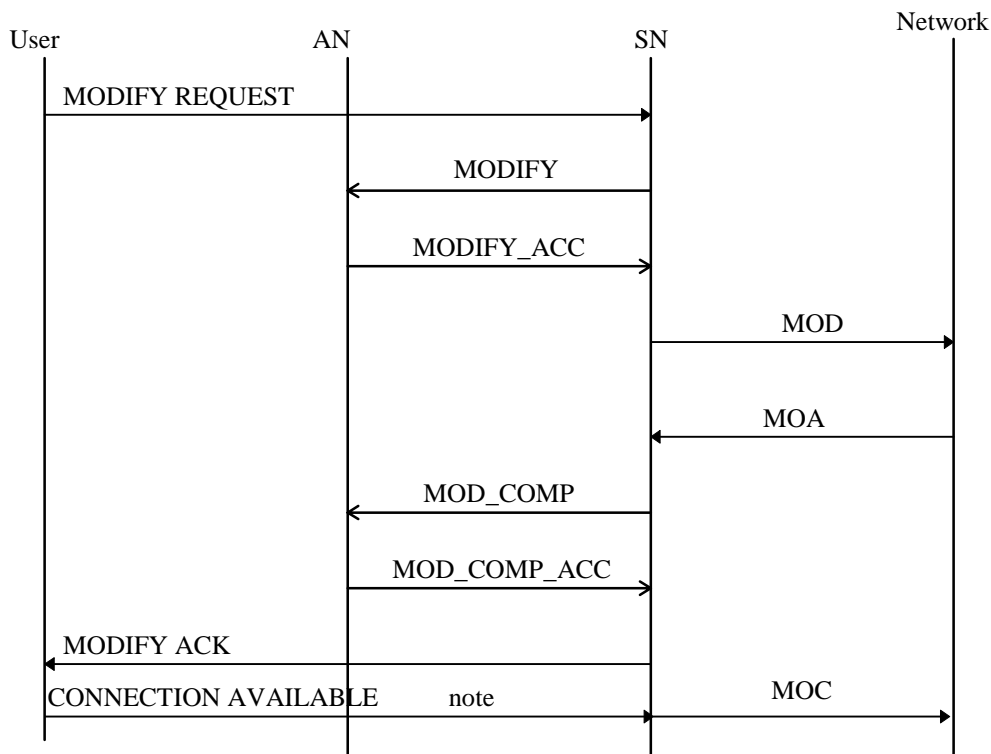

Figure C.4: Connection establishment (originating AN, unsuccessful)

C.1.2 Transfer Phase

C.1.2.1 Successful connection modification at the originating AN



NOTE: The Connection Available message is transparent to the AN and has end to end significance.

Figure C.5: Connection modification (originating AN, successful)

C.1.2.2 Successful connection modification at the terminating AN

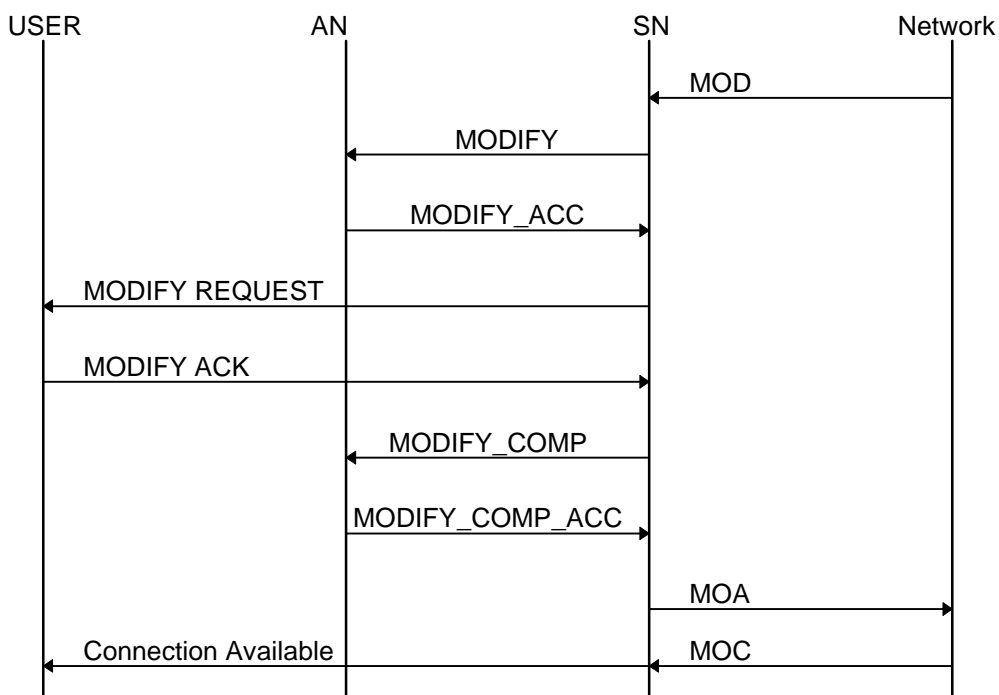

Figure C.6: Connection modification (terminating AN, successful)

C.1.2.3 Unsuccessful connection modification (Example 1: Rejected by network or user)

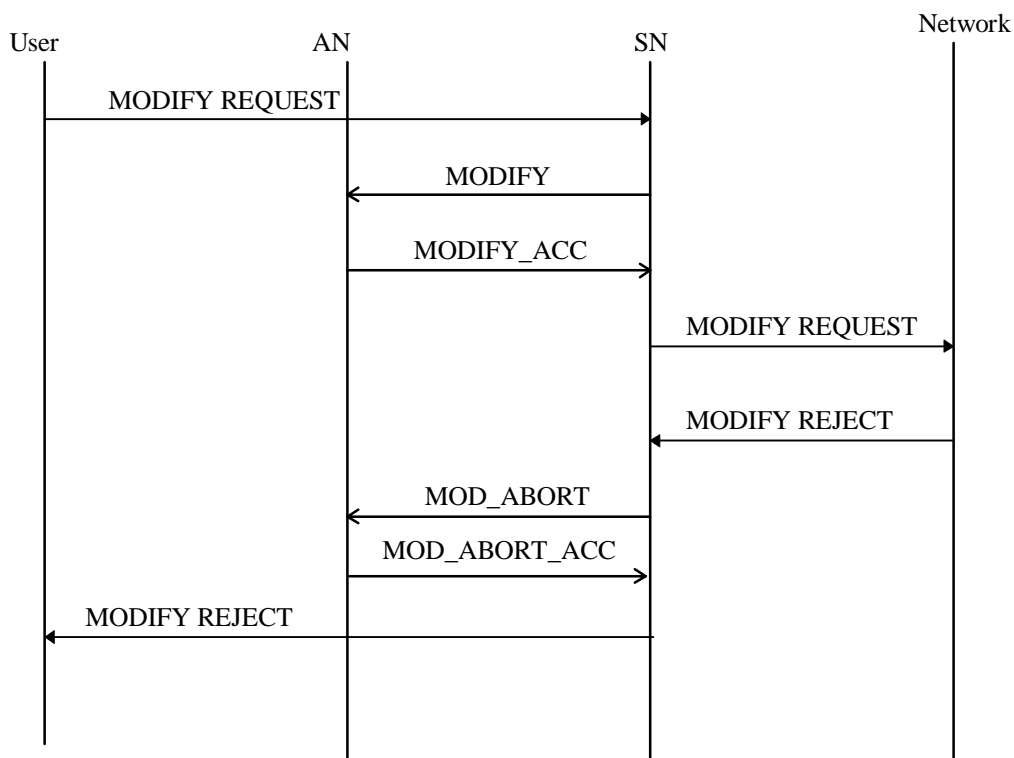

Figure C.7: Connection modification (originating AN, request rejected by network or user)

C.1.2.4 Unsuccessful connection modification (Example 2: Rejected by AN)

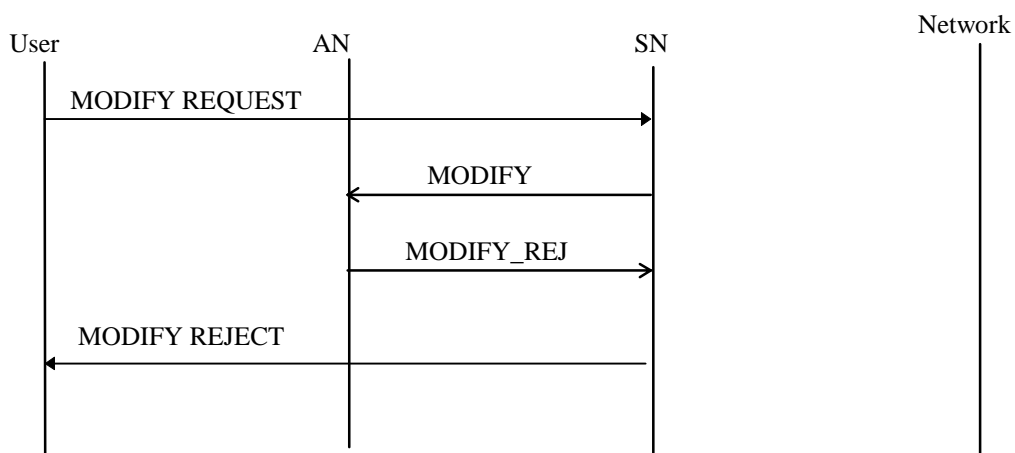
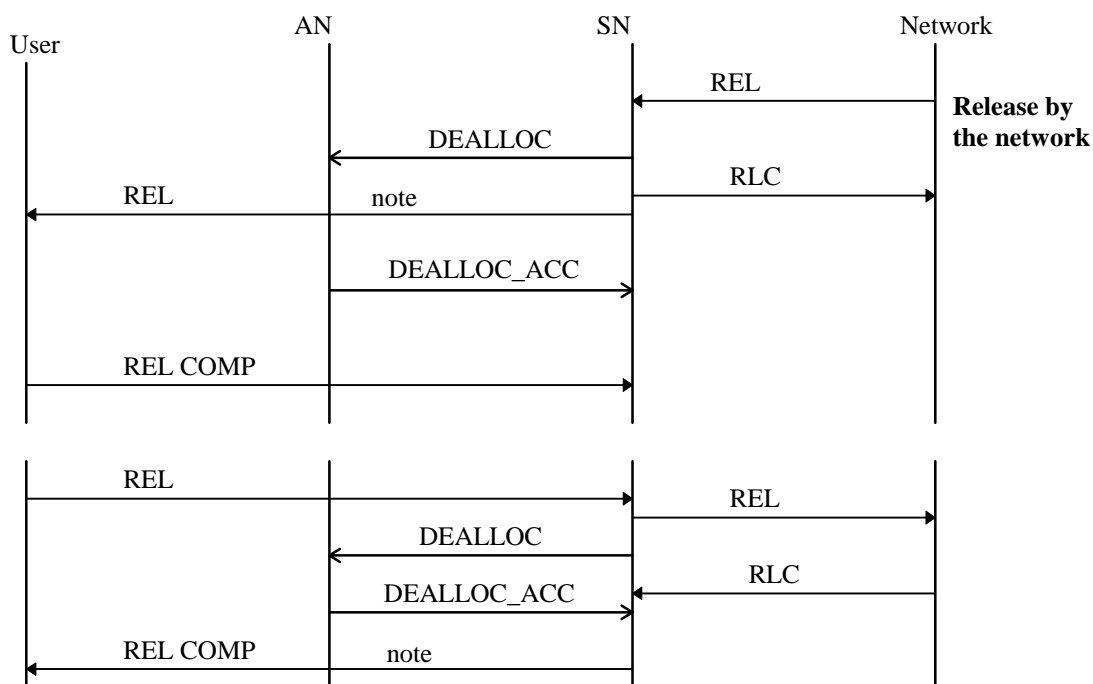

Figure C.8: Connection modification (originating AN, request rejected by AN)

C.1.3 Release of point-to-point connections



NOTE: There is no time dependency between the ALLOCATE procedure and the RELEASE procedure.

Figure C.9: Connection release

C.1.4 Successful establishment of point-to-multipoint connections at the terminating AN

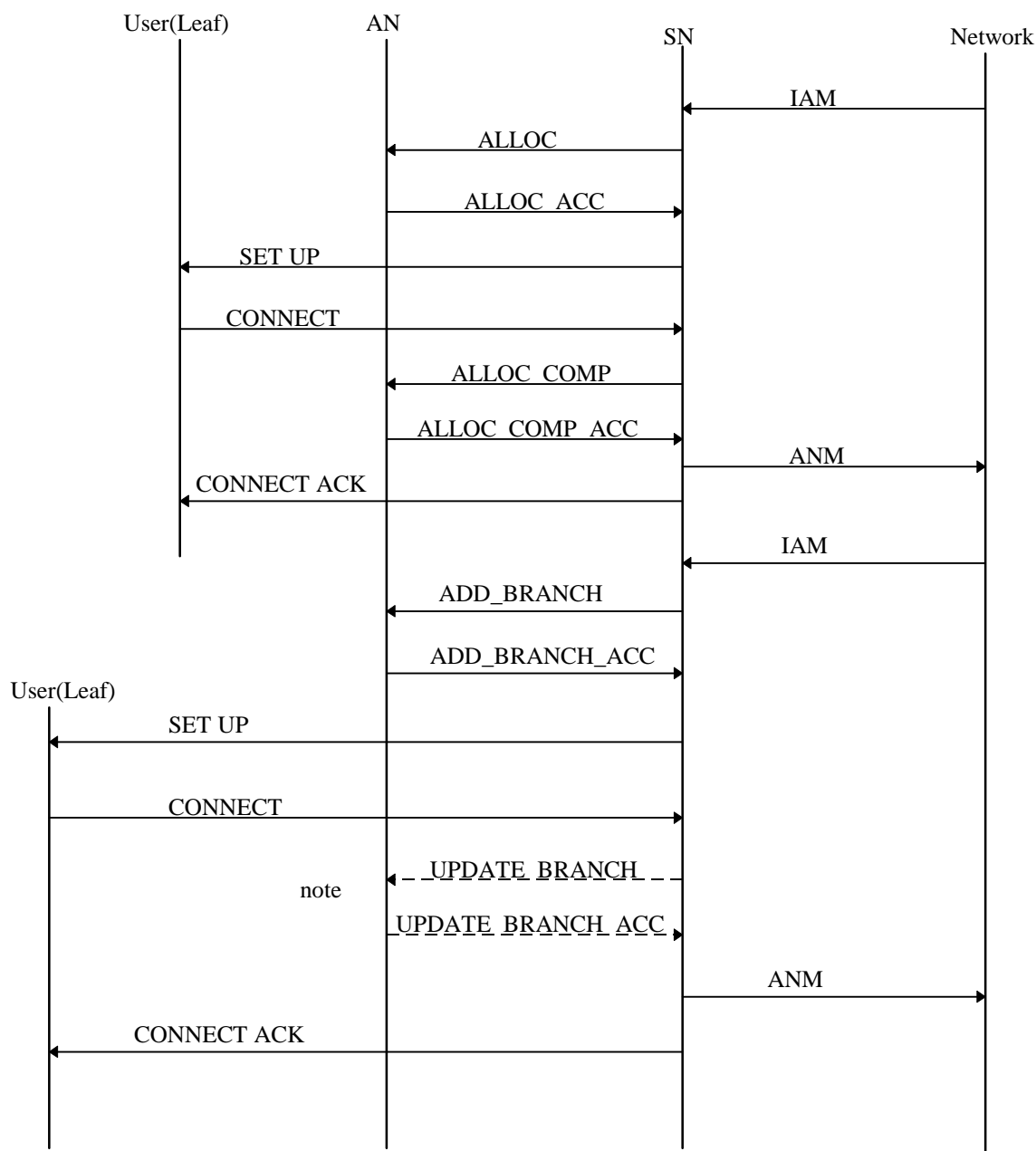

NOTE: This transaction is optional and only necessary if the VPCI/VCI selection is done by the user.

Figure C.10: Establishment of point-to-multipoint connections (originating AN, successful)

C.1.5 Release branches of point-to-multipoint connections

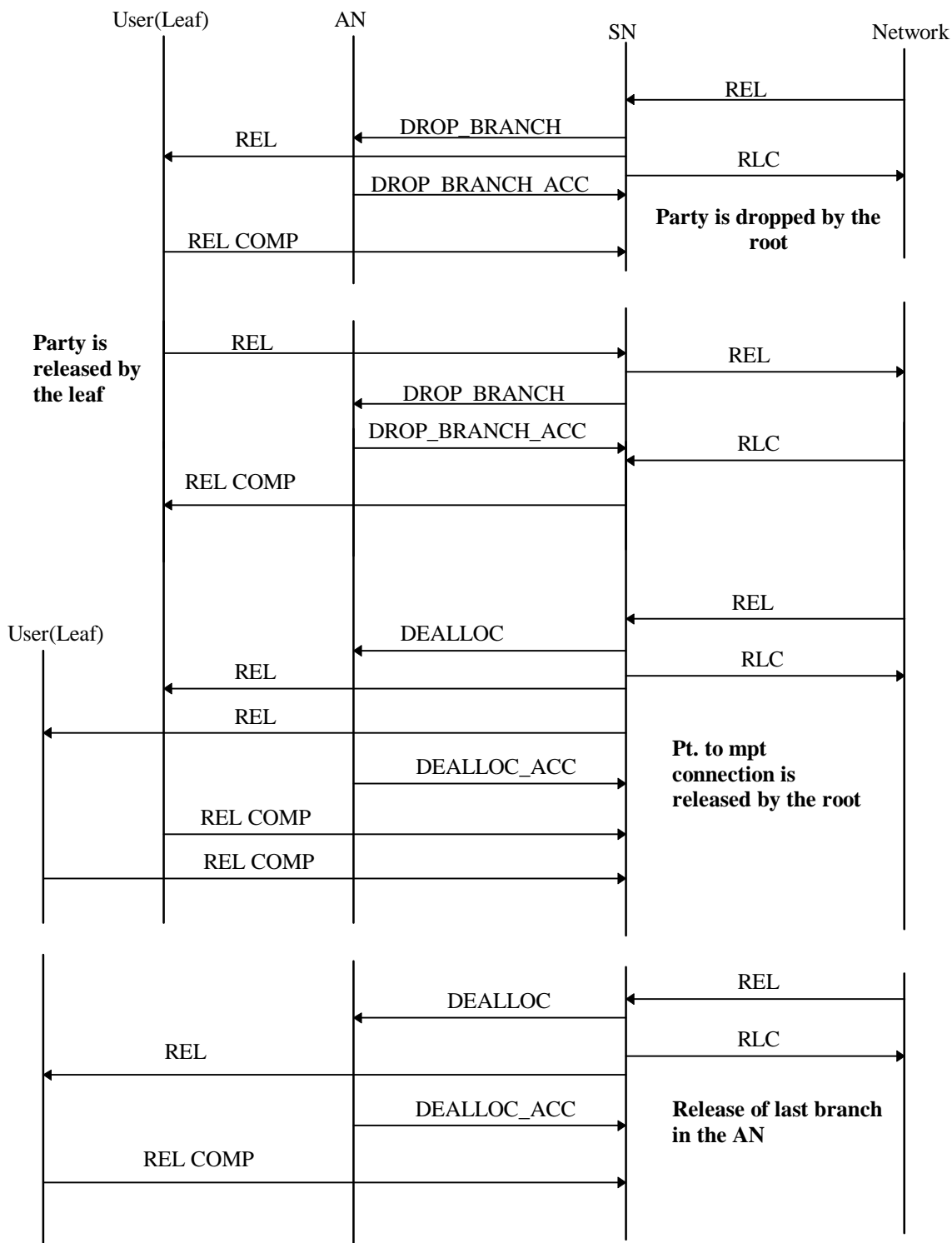
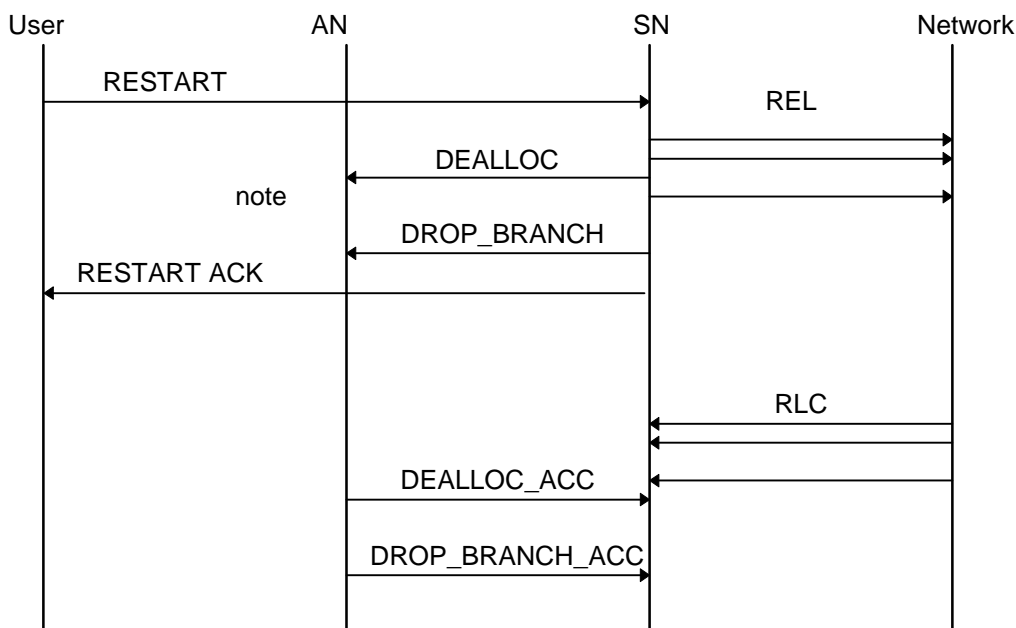

Figure C.11: Release of branches

C.1.6 DSS2 Restart



NOTE: En bloc deallocation / en bloc drop branch is used.

Figure C.12: DSS2 restart

C.2 Common use of information elements in DSS2 and VB5.2

Within DSS2 information elements are defined which describe the characteristics of the requested bearer connection. This information is of relevance for the AN too and therefore has to be introduced in the B-BCC protocol. For reasons of maintainability and ease of interworking the relevant information elements in the B-BCC protocol use whenever possible the same coding as in DSS2 (see subclause 14.3.7).

Call control co-ordination when doing the user side connection handling, exchanges the information elements relevant for VB5.2 with the VB5 B-BCC application function.

Some information elements are manipulated in the AN and returned to the SN. If these information elements are of relevance for the called user they are forwarded by call control co-ordination for inclusion in DSS2 messages or used for interworking according to ITU-T Recommendation Q.2650.

The following tables describe which DSS2 and B-BCC messages use common sets of information elements. Dependent on the service requested only a subset of information elements described in these tables will be used by DSS2 and B-BCC for a certain connection. The assignment of the information elements to the various services is described in the relevant DSS2 specifications.

C.2.1 Point-to-point connections

C.2.1.1 DSS2 SETUP message and B-BCC ALLOC message

This message mapping is done at the originating AN.

Table C.1: Common list of information elements in SETUP/ALLOC messages

ATM traffic descriptor
Broadband bearer capability
End-to-end transit delay
OAM traffic descriptor
Quality of service
ABR set-up parameters
CDVT
Minimum acceptable ATM traffic descriptor
Alternative ATM traffic descriptor
Connection identifier/user port connection identifier note:
NOTE: In VB5.2 connection identification has to be done for the user port and the service port. The DSS2 connection identifier is mapped to the user port connection identifier in VB5.2.

C.2.1.2 DSS2 CONNECT message and B-BCC ALLOC_COMP message

This message mapping is done at the terminating AN.

The CONNECT message may contain resource relevant information e.g. as a result of negotiation. These information elements are also used in the ALLOC_COMP message to allow the AN adaptation of resources.

Table C.2: Common list of information elements in CONNECT/ALLOC_COMP messages

ATM traffic descriptor
ABR set-up parameters
CDVT
Connection identifier/user port connection identifier (note)
NOTE: If the "connection identifier" is included within the DSS2 "Call proceeding" or "Alerting" messages, then it is stored by the SN and finally passed in the ALLOC_COMP message.

C.2.1.3 DSS2 SETUP message and B-BCC ALLOC_ACC message

This mapping is done at the terminating AN.

Only those information elements which are due to potential modification by the AN are returned in the ALLOC_ACC message. Information elements which are of relevance for the called user then are forwarded by call control co-ordination for inclusion in the SETUP message.

Table C.3: Common list of information elements for SETUP/ALLOC_ACC message

ATM traffic descriptor
ABR set-up parameters
CDVT
End-to-end transit delay
Minimum acceptable ATM traffic descriptor
Alternative ATM traffic descriptor
Connection identifier/User port connection identifier

C.2.1.4 DSS2 RELEASE message and B-BCC DEALLOC message

No mapping of information elements from RELEASE messages to VB5 B-BCC DEALLOC is necessary.

C.2.1.5 DSS2 MODIFY REQUEST message and B-BCC MODIFY message

This message mapping is done at the originating AN.

Table C.4: Common list of information elements for MODIFY REQUEST/Modify message

ATM traffic descriptor
Alternative ATM traffic descriptor
Minimum acceptable ATM traffic descriptor

Either the Alternative ATM traffic descriptor information element or Minimum acceptable ATM traffic descriptor information element (but only one of them) shall be included in the MODIFY REQUEST/MODIFY message when traffic parameters are negotiable.

C.2.1.6 DSS2 MODIFY ACKNOWLEDGEMENT message and B-BCC Modify-COMP message

This message mapping is done at the originating AN.

Table C.5: Common list of information elements for MODIFY ACKNOWLEDGEMENT/MODIFY_COMP message

ATM traffic descriptor

If one or more traffic parameters were negotiable the ATM traffic parameter information element is included to specify the traffic parameter values allocated for the modification.

C.2.1.7 DSS2 MODIFY REQUEST message and B-BCC MODIFY_ACC message

This message mapping is done at the terminating AN.

Table C.6: Common list of information elements for MODIFY REQUEST/MODIFY_ACC message

ATM traffic descriptor
Alternative ATM traffic descriptor
Minimum acceptable ATM traffic descriptor

The information elements are applicable if traffic parameter are negotiable.

C.2.1.8 Handling of B-BCC messages of type REJ

The reject cause given by the AN is mapped to the appropriate cause field of the DSS2 message. The mapping table is for further study.

The following message pairs are effected.

B-BCC ALLOC_REJ	DSS2 REL
B-BCC ALLOC_COMP_REJ	DSS2 REL
B-BCC MODIFY_REJ	DSS2 MODIFY REJECT
B-BCC MODIFY_COMP_REJ	DSS2 MODIFY REJECT

C.2.2 Point-to-multipoint connections

C.2.2.1 DSS2 SETUP message and B-BCC ADD_BRANCH_ACC message

This message mapping is done at the terminating AN.

Those information elements which are modified by the AN and are of relevance for the called user then are forwarded by call control co-ordination for inclusion in the SETUP message.

Table C.7: Common list of information elements of SETUP/ADD BRANCH ACC message

Connection identifier/User port connection identifier
End to end transit delay
CDVT

C.2.2.2 DSS2 CONNECT message and B-BCC UPDATE_BRANCH message

This message mapping is done at the terminating AN.

Table C.8: Common list of information elements of CONNECT/UPDATE_BRANCH message

Connection identifier/user port connection identifier

C.2.2.3 Dropping a branch

Besides the association between Call reference and Connection Endpoint reference there is no information element mapping from release messages to drop branch messages.

Annex D (informative): Support of services with susceptibility to clipping

D.1 Case of direct access arrangements

For a direct access arrangement scenario (i.e. no AN is present) the transmission path is completed at the following points:

- Originating SN

If the connection is susceptible to information/speech clipping, then the through connection in the backward direction is completed immediately upon receipt of the B-ISUP IAA message. Through connection of the forward direction shall be completed no later than on receipt of a B-ISUP ANM message.

However if the connection is not susceptible to information/speech clipping, then the through connection in both directions shall be completed no later than on receipt of a B-ISUP ANM message.

- Intermediate SN

If the connection is susceptible to information/speech clipping, then the through connection in the both directions is completed immediately upon receipt of the B-ISUP IAA message.

However if the connection is not susceptible to information/speech clipping, then the through connection in both directions shall be completed no later than on receipt of a B-ISUP ANM message.

- Destination SN

The through connection in the both directions is completed immediately upon receipt of the DSS2 CONNECT message. This action is performed for the cases where the connection is and is not susceptible to information/speech clipping.

D.2 Case of remote access arrangements with VB5.2 reference point

For the remote access arrangement scenario including an AN with VB5.2 reference point the AN could enable its transmission path at the same points as the SN. But this would entail the AN being aware (via the information received by B-BCC messages) of whether the connection is susceptible to information/speech clipping or not. This is not desirable and therefore to ensure that the AN is independent of the susceptibility to information/speech clipping the AN will enable its transmission path at the following points:

- Upon receipt of the ALLOC message the AN will enable the transmission path in the LSP to LUP direction and thus activate NPC.
- Upon receipt of the ALLOC_COMP message the AN will enable the transmission path in the LUP to LSP direction and thus activate UPC.

This will allow the AN to meet the requirements for connections that are susceptible to information/speech clipping and those that are not. This is illustrated in figures D.1 and D.2.

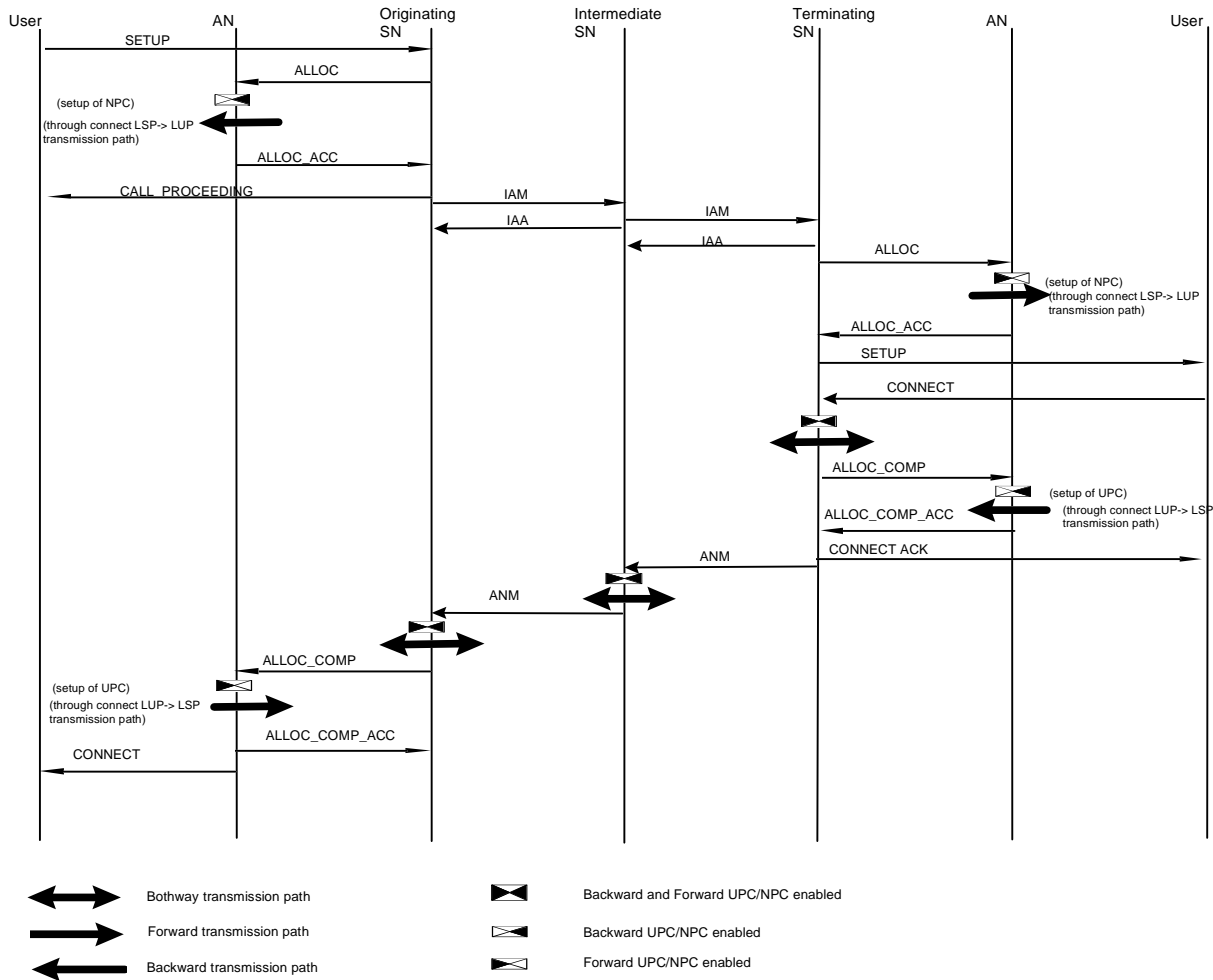

Figure D.1: Connection is not susceptible to information/speech clipping

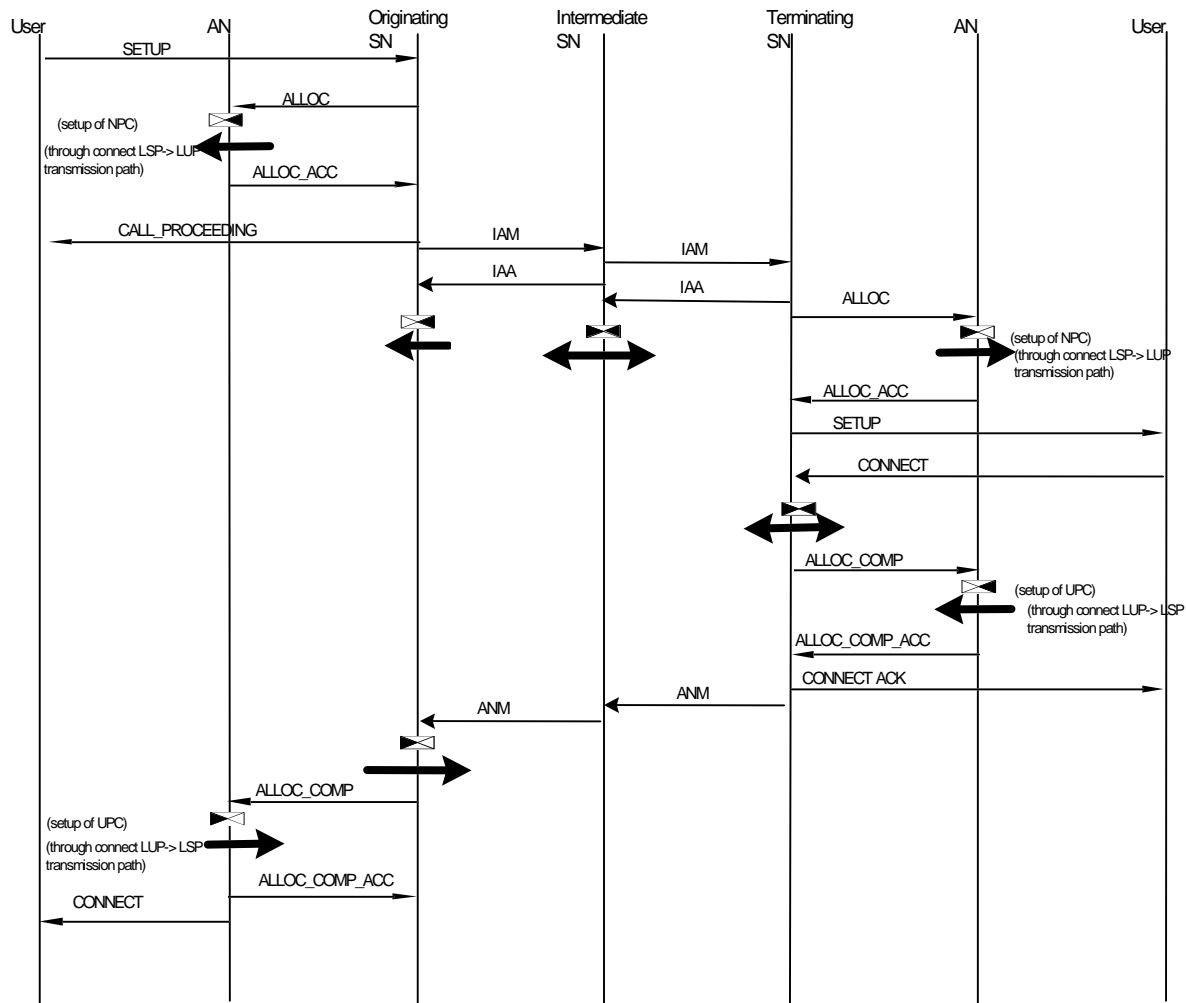

Figure D.2: Connection is susceptible to information/speech clipping

Annex E (informative): RTMC and B-BCC system relationship

This annex describes the system level relationship between the RTMC and B-BCC systems, in particular, the special case of system start-up.

The requirements for B-BCC start-up and B-BCC restart are described in subclause 11.2.7. The related procedures are given in subclauses 13.6.4.5 (B-BCC start-up) and 13.6.4.6 (B-BCC restart). The RTMC start-up procedure is described in subclause 13.3.4.1 of EN 301 005-1 [1].

In the VB5.2 reference point specification the RTMC and B-BCC systems operate independently. In certain circumstances there may be a benefit in co-ordinating the RTMC start-up and the B-BCC start-up/restart to improve the VB5.2 interface performance.

The VB5.2 reference point has been specified such that the B-BCC protocol will still operate if the RTMC protocol fails. If the RTMC has failed, the SN might no longer have visibility of the AN resource availabilities and has to forward all connection requests to the AN. This situation could result in the AN rejecting B-BCC allocation requests, whereas when the RTMC protocol is operating these can be screened in the SN.

The situation is somewhat different in the case of the B-BCC having failed, but the RTMC being functional. In this case, no calls can be offered into the AN via the B-BCC.

During interface start-up it might be advantageous in certain circumstances to delay B-BCC transactions until the RTMC protocol is functional, avoiding the need for the AN to process and reject B-BCC messages unnecessarily. However, any link between the RTMC and the B-BCC is outside the scope of the present document.

Annex F (informative): Potential optimization of the B-BCC protocol to support switched broadcast services

The purpose of this annex is to provide informative material on how the B-BCC protocol specified in the present document can evolve to support additional capabilities for the realization of distribution services (especially with user individual presentation control) as defined in ITU-T Recommendation I.211 [53]. The requirements for the definition of the additional capabilities are based on the application for the support switched broadcast services, e.g. switched video broadcasting (SVB), in remote access arrangements across interfaces at the VB5.2 reference point. However this application is only taken as one example for the possible realizations of distribution services as described in ITU-T Recommendation I.211 [53].

F.1 General

Switched Video Broadcasting is one of the attractive application for the SN (i.e., digital video server). This service is typically composed of separate information channel types, one for the user individual presentation control (called "zapping" in the further description) and additional ones for the transport of the video signal. The zapping function realizes the required switching of video sources to select a particular channel in a bundle of broadcasted channels.

General broadcasting services such as CATV and Satellite (DVB), send all video signals to the CPE, and the terminal selects a particular video signal. Using a remote access arrangement that provides a very limited capacity at the customer access line (e.g. using PON and/or xDSL technologies), it may not be possible to broadcast many video signals to the CPE. It is required to switch video signals within the network and to provide a fast channel selection procedure as if all video signals were broadcasted to the CPE. Each video signal is carried by a VCC as root of a point-to-multipoint connection in the ATM network and is switched to a leaf according to the video channel number which is selected by zapping control.

The architecture shown in figure F.1 is one of the architectures to provide the SVB service. This architecture uses the B-BCC protocol to support the zapping function. In order to optimize the procedures, particular extensions to the capabilities of the B-BCC protocol specified in this Recommendation are identified.

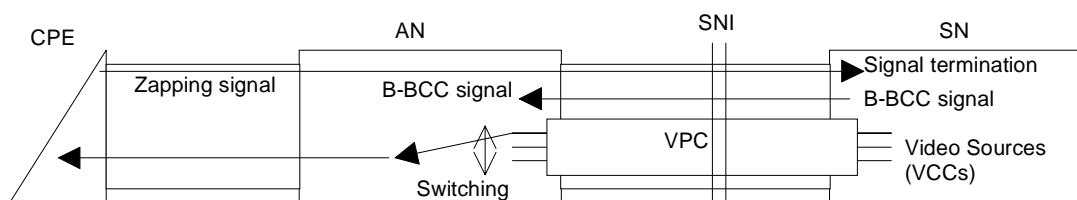

Figure F.1: SDV architecture that related VB5.2 reference point

F.1.1 New requirements for VB5.2 reference point

To provide an SVB service using the capabilities of the B-BCC protocol specified in this Recommendation, the following complex procedures are required.

- 1) For the first user of a video channel, the SN is required to allocate a new point to multipoint connection via the bearer connection establishment procedure (i.e., using the ALLOC and ALLOC_COMP message).
- 2) For the second or later user of an active video channel, the SN is required to add a new leaf via the branch establishment procedure (i.e., using the ADD_BRANCH message).
- 3) When the user quits a video channel, the SN is required to drop a leaf via the branch release procedure (i.e., using the DROP_BRANCH message).
- 4) When the last user quits a video source, the SN is required to release the point to multipoint connection via the bearer connection release procedure (i.e., using the DEALLOC message).

- 5) When the user wants to change a video channel (i.e., zapping), the SN is required to apply two procedures in sequence. At first the SN is required to drop the leaf from the root or deallocate the connection depending on the actual status of the particular video channel in the AN. Then the SN is required to establish the leaf or establish a new connection depending on the status of the new video channel in the AN.

To provide optimized procedures for the support of SVB services the following extensions to the functions provided by the B-BCC protocol are identified.

- 1) A procedure which enables the establishment of a root link across the VB5.2 reference point without simultaneous establishment of a leaf to a user port (see figure F.2).
- 2) A procedure that is a combination of a drop branch transaction and an add branch transaction(see figure F.3).

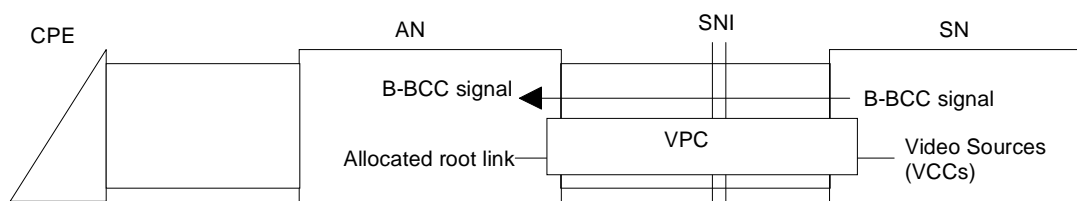

Figure F.2: Root link allocation at VB5.2 reference point

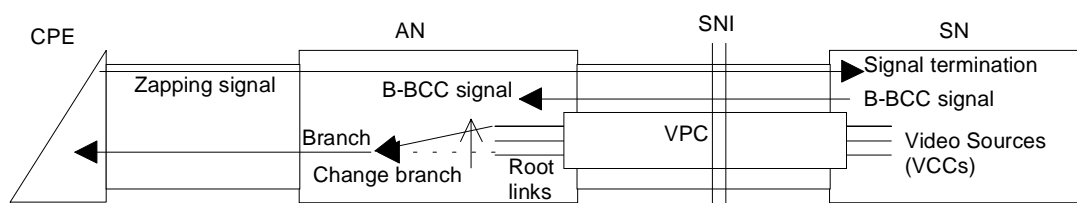

Figure F.3: Change of a branch in the AN

F.2 Additional B-BCC procedures

F.2.1 Link establishment procedure

F.2.1.1 General

The root link establishment procedure provides the communication procedures between SN and AN VB5.2 application functions to enable the establishment of the root link of a point-to-multipoint connection in AN, without simultaneously establishing a first branch to a user port.

The link establishment procedures differs from the from bearer connection establishment procedure as follows:

- a) The procedure consists of a single transaction, since negotiation parameters is not required.
- b) In the AN, only a simple CAC function has to be applied because a link establishment at the user port and an inter-connection between LUP and LSP is not required.
- c) The procedure may be optimized to allow for the establishment of multiple root links in one transaction.

F.2.1.2 Procedure

The link establishment procedure consists of a single transaction. The procedure is triggered at the SN B-BCC system by the SN VB5.2 application functions via a `ceeLinkAllocReq` primitive. This primitive contains relevant bearer connection parameters, but for the LSP side only. On receipt of the `LINK_ALLOC` message, the AN B-BCC system indicates the request to the AN VB5.2 application function. Depending on the decision made by the AN VB5.2 application functions, either a `LINK_ALLOC_ACC` or a `LINK_ALLOC_REJ` message will be sent back to the SN.

F.2.1.3 Exceptional procedures

In addition to the general error handling described in subclause 13.6.1.5, the following rule apply:

When the AN B-BCC system receives a LINK_ALLOC message containing a connection reference number which is already assigned in the AN, no action shall be taken on the message and a LINK_ALLOC_REJ message containing a reject cause value of "message not compatible with connection state" shall be sent to the SN.

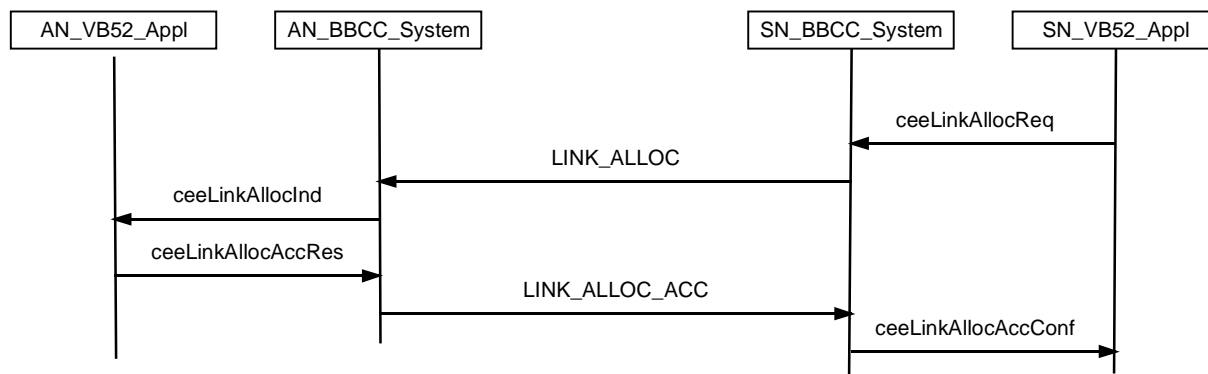

Figure F.4: Link establishment procedure

F.2.2 Change branch procedure

F.2.2.1 General

The change branch procedure is a combination of the branch release and the branch establishment described in subclause 13.6. It enables the release of a branch of a point-to-multipoint connection and the establishment of a new branch of a different bearer connection via a single transaction.

When this procedure is applied, the user port VPCI/VCI combination of the branch to be released and the user port VPCI/VCI combination for the branch to be established shall be identical.

F.2.2.2 Procedure

The change branch procedure consists of a single transaction. The procedure is triggered at the SN B-BCC system by the SN VB5.2 application functions via a ceeChangeBranchReq primitive. This primitive contains relevant identifiers for the branch to be released and the branch to be established. On receipt of the CHANGE_BRANCH message, the AN B-BCC system indicates the request to the AN VB5.2 application function. Depending on the decision made by the AN VB5.2 application functions, either a CHANGE_BRANCH_ACC or a CHANGE_BRANCH_REJ message will be sent back to the SN.

F.2.2.3 Exceptional procedures

In addition to the general error handling described in subclause 13.6.1.5, the following rules apply:

- When the AN B-BCC system receives a CHANGE_BRANCH message with respect to a connection which has not been established, no action shall be taken on the message and a CHANGE_BRANCH_REJ message containing a reject cause value of "message not compatible with connection state" shall be sent to the SN.
- When the AN B-BCC system receives a CHANGE_BRANCH message containing a branch identifier which is not assigned in the AN, no action shall be taken on the message and a CHANGE_BRANCH_REJ message containing a reject cause value of "message not compatible with connection state" shall be sent to the SN.
- When the AN B-BCC system receives a CHANGE_BRANCH message containing for a branch identifier for the new branch which is already assigned in the AN, no action shall be taken on the message and a CHANGE_BRANCH_REJ message containing a reject cause value of "message not compatible with connection state" shall be sent to the SN.

- d) When the AN B-BCC system receives an CHANGE_BRANCH message with respect to a point-to-point connection, no action shall be taken on the message and a CHANGE_BRANCH_REJ message containing a reject cause value of "message not compatible with connection state" shall be sent to the SN.

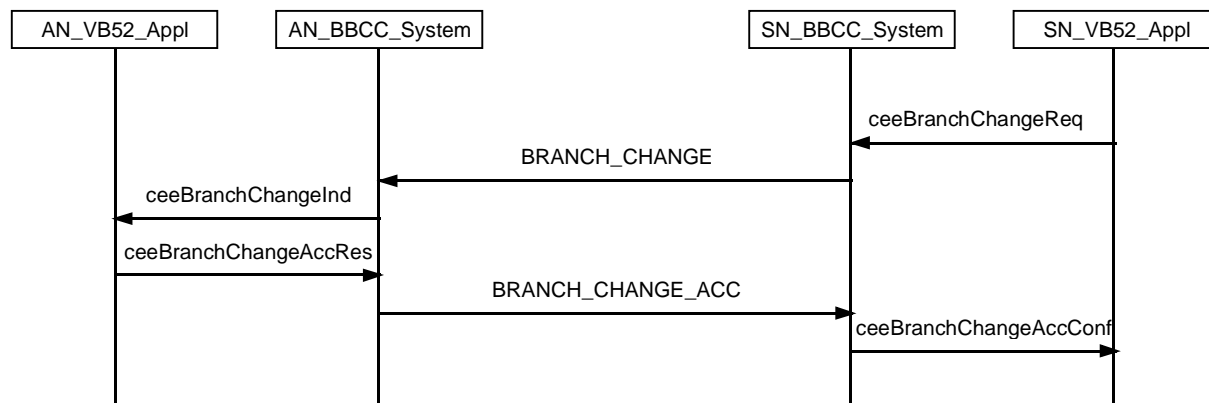

Figure F.5: Change branch procedure

F.3 Extended B-BCC message format and codes

F.3.1 Additional B-BCC messages

F.3.1.1 Message type coding

Table F.1: Extended VB5.2 B-BCC protocol message type coding

Message type (octet 6)								bits	Reference
8	7	6	5	4	3	2	1		
0	1	0	x	x	x	x	x	VB5.2 B-BCC protocol message types	
		1	0	0	1	0	0	LINK_ALLOC	F.3.1.2
		1	0	0	1	0	1	LINK_ALLOC_ACC	F.3.1.3
		1	0	0	1	1	0	LINK_ALLOC_REJ	F.3.1.4
		1	0	0	1	1	1	CHANGE_BRANCH	F.3.1.5
		1	0	1	0	0	0	CHANGE_BRANCH_ACC	F.3.1.6
		1	0	1	0	0	1	CHANGE_BRANCH_REJ	F.3.1.7
All other values are reserved.									

F.3.1.2 LINK_ALLOC message

This message is used by the SN to request the AN to establish a root link (represented by a VC link) at a particular logical service port. The message is composed by the common message information given in table 22 and the information elements given in table F.2.

Table F.2: LINK_ALLOC message content

Information Elements	Reference	Type	Length
Connection reference number	14.3.6.2	M	7
ATM traffic descriptor	14.3.7.1	M	12 to 30
Broadband bearer capability	14.3.7.2	M	6 to 7
QoS parameters	14.3.7.4	M	6
Service port connection identifier	14.3.6.5	M	9

F.3.1.3 LINK_ALLOC_ACC message

This message is used by the AN to notify the SN that the allocation of the root link requested by the SN has been accepted. The message is composed by the common message information given in table 22 and the information elements given in table F.3.

Table F.3: LINK_ALLOC_ACC message content

Information Elements	Reference	Type	Length
Automatic congestion level	14.3.6.8	O	4 to 5

F.3.1.4 LINK_ALLOC_REJ message

This message is used by the AN to notify the SN that the allocation of the root link requested by the SN has not been accepted. The message is composed by the common message information given in table 22 and the information elements given in table F.4.

Table F.4: LINK_ALLOC_REJ message content

Information Elements	Reference	Type	Length
Reject cause	14.3.6.9	M	5
Automatic congestion level	14.3.6.8	O	4 to 5

F.3.1.5 CHANGE_BRANCH message

This message is used by the SN to request from the AN the change of a branch from previous root link to another root link. The message is composed of the common message information given in table 22 and the information elements given table F.5.

Table F.5: CHANGE_BRANCH message content

Information Elements	Reference	Type	Length
Old/new branch identifier	F.3.2.2	M	14

F.3.1.6 CHANGE_BRANCH_ACC message

This message is used by the AN to notify the SN that a branch has been successfully changed a root. The message is composed of the common message information given in table 22 and the information elements given table F.6.

Table F.6: CHANGE_BRANCH_ACC message content

Information Elements	Reference	Type	Length
Automatic congestion level	14.3.6.8	O	4 to 5

F.3.1.7 CHANGE_BRANCH_REJ message

This message is used by the AN to notify the SN that a branch has not been changed a root. The message is composed of the common message information given in table 22 and the information elements given table F.7.

Table F.7: CHANGE_BRANCH_REJ message content

Information Elements	Reference	Type	Length
Reject cause	14.3.6.9	M	5
Automatic congestion level	14.3.6.8	O	4 to 5

F.3.2 Additional B-BCC information element

F.3.2.1 Information element type coding

Table F.8: Extended VB5.2 B-BCC protocol information element type coding

Information element type (octet N + 1)									Reference
8	7	6	5	4	3	2	1	bits	
0	0	0	1	0	1	0	0	Old/new branch identifier	F.3.2.2

F.3.2.2 Old/new branch identifier

The purpose of the old/new branch identifier information element is to identify the branch to be released and the branch to be established.

The information element is composed of the common octets given in table 52 and the octets shown in figure F.6. The length of this information element is 14 octets.

Bits								Octet
8	7	6	5	4	3	2	1	
_____								N + 5
_____ Connection reference number value (note 1) _____								N + 6
_____								N + 7
_____ Branch identifier value (note 1) _____								N + 8
_____								N + 9
_____ Connection reference number value (note 2) _____								N + 10
_____								N + 11
_____ Branch identifier value (note 2) _____								N + 12
_____								N + 13
_____								N + 14

NOTE 1: Identification of the branch to be released.

NOTE 2: Identification of the branch to be established.

Figure F.6: Old/new branch identifier information element coding

Bibliography

DEN/TMN-00003: "V Interfaces at the digital Service Node (SN); Management Interfaces associated with the VB5.2 reference Point; Part 1: Interface specification".

NOTE 1: Not yet publicly available

DEN/SPS-03049-1: "V Interfaces at the digital Service Node (SN); Management Interfaces associated with the VB5.1 Reference Point; Part 1: Interface Specification".

ITU-T Recommendation Q.298x

NOTE 2: Not yet published

The ATM Forum Technical Committee af-sig-0061.000 (07/96) - ATM User-Network Interface (UNI) Signalling Specification Version 4.0.

The ATM Forum Technical Committee af-tm-0056.000 (04/96) - Traffic Management Specification Version 4.0.

The ATM Forum Technical Committee (1994) - ATM User-Network Interface (UNI) Signalling Specification Version 3.1.

ITU-T Recommendation G.967-1: "V-interfaces at the service node (SN); VB5.1 reference point specification".

NOTE 3: Not yet published.

ITU-T Recommendation I.324 (1991): "ISDN network architecture".

ITU-T Recommendation I.327 (1993): "B-ISDN functional architecture".

ITU-T Recommendation I.751 (1996): "Asynchronous transfer mode management of the network element view".

DEN/SPS-03047-2: "Interfaces at VB5.2 reference point for the support of broadband or combined narrowband/broadband access networks; Part 2: Protocol Implementation Conformance Statement (PICS)".

NOTE 4: Not yet publicly available

History

Document history		
V1.1.1	July	Public Enquiry PE 9846: 1998-07-17 to 1998-11-13