

EN 301 199 V1.2.1 (1999-06)

European Standard (Telecommunications series)

Digital Video Broadcasting (DVB); Interaction channel for Local Multi-point Distribution Systems (LMDS)

European Broadcasting Union



Union Européenne de Radio-Télévision

DVB
Digital Video
Broadcasting



Reference

REN/JTC-DVB-79 (b3o00ioo.PDF)

Keywords

DVB, digital, video, broadcasting, interaction, TV

ETSI

Postal address

F-06921 Sophia Antipolis Cedex - FRANCE

Office address

650 Route des Lucioles - Sophia Antipolis
Valbonne - FRANCE
Tel.: +33 4 92 94 42 00 Fax: +33 4 93 65 47 16
Siret N° 348 623 562 00017 - NAF 742 C
Association à but non lucratif enregistrée à la
Sous-Préfecture de Grasse (06) N° 7803/88

Internet

secretariat@etsi.fr
Individual copies of this ETSI deliverable
can be downloaded from
<http://www.etsi.org>
If you find errors in the present document, send your
comment to: editor@etsi.fr

Copyright Notification

No part may be reproduced except as authorized by written permission.
The copyright and the foregoing restriction extend to reproduction in all media.

© European Telecommunications Standards Institute 1999.
© European Broadcasting Union 1999.
All rights reserved.

Contents

Intellectual Property Rights	6
Foreword	6
1 Scope	7
2 References	7
3 Abbreviations	8
4 Reference Model for System Architecture of Narrowband Interaction Channels in a Broadcasting Scenario (Asymmetric Interactive Services)	9
4.1 Protocol Stack Model	9
4.2 System Model	10
5 DVB Interaction Channel Specification for LMDS Networks	13
5.1 System Concept	13
5.1.1 Out-Of-Band / In-Band Principle	13
5.1.2 Spectrum Allocation	14
5.1.3 FDMA/TDMA Multiple Access	15
5.1.4 Bit Rates and Framing	16
5.2 Lower Physical Layer Specification	17
5.2.1 Forward Interaction Path (Downstream OOB)	19
5.2.1.1 Frequency Range (Downstream OOB)	19
5.2.1.2 Modulation and Mapping (Downstream OOB)	19
5.2.1.3 Shaping Filter (Downstream OOB)	20
5.2.1.4 Randomizer (Downstream OOB)	21
5.2.1.5 Bit Rate (Downstream OOB)	21
5.2.1.6 Receiver Power Level (Downstream OOB) (informative)	21
5.2.1.7 Summary (Downstream OOB)	22
5.2.1.8 Bit Error Rate Downstream OOB (Informative)	22
5.2.2 Forward Interaction Path (Downstream IB)	23
5.2.3 Return Interaction Path (Upstream)	23
5.2.3.1 Frequency Range (Upstream)	23
5.2.3.2 Modulation and Mapping (Upstream)	23
5.2.3.3 Shaping Filter (Upstream)	24
5.2.3.4 Randomizer (Upstream)	25
5.2.3.5 Bit Rate (Upstream)	25
5.2.3.6 Transmit Power Level (Upstream) (informative)	26
5.2.3.7 Upstream Burst Power and Timing Profiles	26
5.2.3.8 Interference (Spurious) Suppression	26
5.2.3.9 Summary (Upstream)	27
5.2.3.10 Packet Loss Upstream (Informative)	28
5.2.3.11 Maximum Delay	28
5.3 Framing	28
5.3.1 Forward Interaction Path (Downstream OOB)	28
5.3.1.1 Signalling Link Extended Superframe Framing Format	28
5.3.1.2 Frame overhead	29
5.3.1.3 Payload Structure	30
5.3.2 Forward Interaction Path (Downstream IB)	37
5.3.2.1 IB Signalling MPEG2-TS Format (MAC Control Message)	37
5.3.2.2 Frequency of IB Signalling Information	39
5.3.3 Return Interaction Path (Upstream)	40
5.3.3.1 Slot Format	40
5.3.4 Minimum Processing Time	41
5.4 Slot Timing Assignment	42
5.4.1 Downstream Slot Position Reference (Downstream OOB)	42
5.4.2 Downstream Slot Position Reference (Downstream IB)	42

5.4.3	Upstream Slot Positions	44
5.4.3.1	Rate 256 kbit/s.....	44
5.4.3.2	Void.....	44
5.4.3.3	Rate 1,544 Mbit/s	44
5.4.3.4	Rate 3,088 Mbit/s	45
5.4.3.5	Rate 6,176 Mbit/s	46
5.4.4	Slot Position Counter	47
5.5	MAC Functionality	48
5.5.1	MAC Reference Model	48
5.5.2	MAC Concept	48
5.5.2.1	Relationship Between Higher Layers and MAC Protocol	48
5.5.2.2	Relationship Between Physical Layer and MAC Protocol	49
5.5.2.3	Relationship Between Physical Layer Slot Position Counter and MAC Slot Assignment.....	51
5.5.2.4	Access Modes (Contention / Ranging / Fixed rate / Reservation)	51
5.5.2.5	MAC Error Handling Procedures	52
5.5.2.6	MAC Messages in the Mini Slots	52
5.5.2.7	MAC Message Format.....	55
5.5.3	MAC Initialization and Provisioning	58
5.5.3.1	<MAC> Provisioning Channel Message (Broadcast OOB Downstream)	59
5.5.3.2	<MAC> Default Configuration Message (Broadcast Downstream).....	60
5.5.4	Sign On and Calibration.....	64
5.5.4.1	<MAC> Sign-On Request Message (Broadcast Downstream).....	65
5.5.4.2	<MAC> Sign-On Response Message (Upstream Ranging).....	66
5.5.4.3	<MAC> Ranging and Power Calibration Message (Singlecast Downstream).....	68
5.5.4.4	<MAC> Ranging and Power Calibration Response Message (Upstream Ranging or reserved)	70
5.5.4.5	<MAC> Initialization Complete Message (Singlecast Downstream)	70
5.5.4.6	Frequency ranging	71
5.5.5	Connection Establishment	71
5.5.5.1	Establishment of the First (Initial) Connection	72
5.5.5.2	Establishment of Additional Connections.....	77
5.5.6	Connection Release.....	79
5.5.7	Fixed Rate Access	80
5.5.8	Contention Based Access	80
5.5.9	Reservation Access	81
5.5.10	MAC Link Management.....	86
5.5.10.1	Power and Timing Management	86
5.5.10.2	TDMA Allocation Management	86
5.5.10.3	Channel Error Management.....	89
5.5.10.4	Link Management Messages.....	90
5.6	Minislots	97
5.6.1	Carrying Minislots.....	97
5.6.2	Minislot framing structure.....	98
5.6.3	Contention resolution for minislots	98
5.7	Security (optional)	99
5.7.1	Cryptographic primitives.....	100
5.7.1.1	Public key exchange	100
5.7.1.2	Hashing.....	100
5.7.1.3	Encryption	101
5.7.1.4	Pseudo-random numbers	101
5.7.2	Main Key Exchange, MKE	101
5.7.3	Quick Key Exchange, QKE.....	102
5.7.4	Explicit Key Exchange, EKE	102
5.7.5	Key derivation.....	103
5.7.6	Data stream processing.....	103
5.7.6.1	Payload streams	103
5.7.6.2	Data encryption	103
5.7.6.3	Encryption flags.....	104
5.7.6.4	Chaining and initialization vector.....	104
5.7.7	Security Establishment	104
5.7.8	Persistent state variables.....	105

5.7.8.1	Guaranteed delivery.....	105
5.7.9	Security MAC Messages.....	106
5.7.9.1	<MAC>Security Sign-On (Single-cast Downstream).....	106
5.7.9.2	<MAC>Security Sign-On Response (Upstream).....	107
5.7.9.3	<MAC>Main Key Exchange (Single-cast Downstream).....	107
5.7.9.4	<MAC>Main Key Exchange Response (Upstream).....	108
5.7.9.5	<MAC>Quick Key Exchange (Single-cast Downstream).....	109
5.7.9.6	<MAC>Quick Key Exchange Response (Upstream).....	109
5.7.9.7	<MAC>Explicit Key Exchange (Single-cast Downstream).....	110
5.7.9.8	<MAC>Explicit Key Exchange Response (Upstream).....	110
5.7.9.9	<MAC>Wait (Upstream).....	111
6	Interactive STB / Data Modem Mid Layer Protocol.....	111
6.1	Direct IP.....	111
6.1.1	Framing.....	112
6.1.1.1	Upstream and OOB Downstream.....	112
6.1.1.2	IB Downstream.....	112
6.1.2	Addressing.....	112
6.1.2.1	IP Broadcast and Multicast from STB/NIU to INA.....	112
6.1.2.2	IP Broadcast and Multicast from INA to STB/NIU.....	112
6.1.3	IP Address Assignment.....	112
6.1.4	INA Interfaces (informative).....	113
6.1.5	NIU/STB Interfaces (informative).....	113
6.2	Ethernet MAC Bridging.....	113
6.2.1	Framing.....	113
6.2.1.1	Upstream and OOB Downstream.....	113
6.2.1.2	IB Downstream.....	113
6.2.2	Addressing.....	113
6.3	PPP.....	113
6.3.1	Framing.....	113
6.3.1.1	Upstream and OOB Downstream.....	113
6.3.1.2	IB Downstream.....	114
6.3.2	Addressing.....	114
6.3.3	IP Address Assignment.....	114
6.3.4	Additional IP addresses.....	114
6.3.5	Security.....	114
6.3.6	INA Interfaces (informative).....	114
6.3.7	NIU/STB Interfaces (informative).....	114
Annex A (informative):	MAC State Transitions and Time Outs.....	115
A.1	Ranging and Calibration.....	115
A.2	Connection Establishment.....	119
A.3	Connection Release.....	120
A.4	Reservation Process.....	121
A.5	Re-calibration.....	124
A.6	Reprovision Message.....	124
A.7	Transmission Control Message.....	124
A.8	Status Request Message.....	125
A.9	Idle Message.....	125
	Bibliography.....	126
	History.....	127

Intellectual Property Rights

IPRs essential or potentially essential to the present document may have been declared to ETSI. The information pertaining to these essential IPRs, if any, is publicly available for **ETSI members and non-members**, and can be found in SR 000 314: "*Intellectual Property Rights (IPRs); Essential, or potentially Essential, IPRs notified to ETSI in respect of ETSI standards*", which is available **free of charge** from the ETSI Secretariat. Latest updates are available on the ETSI Web server (<http://www.etsi.org/ipr>).

Pursuant to the ETSI IPR Policy, no investigation, including IPR searches, has been carried out by ETSI. No guarantee can be given as to the existence of other IPRs not referenced in SR 000 314 (or the updates on the ETSI Web server) which are, or may be, or may become, essential to the present document.

Foreword

This European Standard (Telecommunications series) has been produced by the Joint Technical Committee (JTC) Broadcast of the European Broadcasting Union (EBU), Comité Européen de Normalisation ELEctrotechnique (CENELEC) and the European Telecommunications Standards Institute (ETSI).

NOTE: The EBU/ETSI JTC Broadcast was established in 1990 to co-ordinate the drafting of standards in the specific field of broadcasting and related fields. Since 1995 the JTC Broadcast became a tripartite body by including in the Memorandum of Understanding also CENELEC, which is responsible for the standardization of radio and television receivers. The EBU is a professional association of broadcasting organizations whose work includes the co-ordination of its members' activities in the technical, legal, programme-making and programme-exchange domains. The EBU has active members in about 60 countries in the European broadcasting area; its headquarters is in Geneva.

European Broadcasting Union
 CH-1218 GRAND SACONNEX (Geneva)
 Switzerland
 Tel: +41 22 717 21 11
 Fax: +41 22 717 24 81

Founded in September 1993, the DVB Project is a market-led consortium of public and private sector organizations in the television industry. Its aim is to establish the framework for the introduction of MPEG-2 based digital television services. Now comprising over 200 organizations from more than 25 countries around the world, DVB fosters market-led systems, which meet the real needs, and economic circumstances, of the consumer electronics and the broadcast industry.

National transposition dates	
Date of adoption of this EN:	28 May 1999
Date of latest announcement of this EN (doa):	31 August 1999
Date of latest publication of new National Standard or endorsement of this EN (dop/e):	29 February 2000
Date of withdrawal of any conflicting National Standard (dow):	29 February 2000

1 Scope

The present document is the baseline specification for the provision of the interaction channel for LMDS networks. This version supersedes the previous version 1.1.1 of this standard.

It is not intended to specify a return channel solution associated to each broadcast system because the inter-operability of different delivery media to transport the return channel is desirable.

The solutions provided in the present document for interaction channel for LMDS networks are a part of a wider set of alternatives to implement interactive services for Digital Video Broadcasting (DVB) systems.

The present document is not limited to a given frequency range. All the frequencies refer to IF frequencies as defined in subclause 5.1.2.

2 References

The following documents contain provisions which, through reference in this text, constitute provisions of the present document.

- References are either specific (identified by date of publication, edition number, version number, etc.) or non-specific.
- For a specific reference, subsequent revisions do not apply.
- For a non-specific reference, the latest version applies.
- A non-specific reference to an ETS shall also be taken to refer to later versions published as an EN with the same number.

- [1] ITU-T Recommendation I.432: "B-ISDN User-Network Interface - Physical layer specification".
- [2] ETS 300 800: "Digital Video Broadcasting (DVB); Interaction channel for Cable TV distribution systems (CATV)".
- [3] EN 301 192: "Digital Video Broadcasting (DVB); DVB specification for data broadcasting".
- [4] EN 300 421: "Digital Video Broadcasting (DVB); Framing structure, channel coding and modulation for 11/12 GHz satellite services".
- [5] TR 100 815: "Digital Video Broadcasting (DVB); Guidelines for the handling of ATM signals in DVB systems".
- [6] EN 300 468: "Digital Video Broadcasting (DVB); Specification for Service Information (SI) in DVB systems".
- [7] ITU-T Recommendation I.361: "B-ISDN ATM layer specification".
- [8] ITU-T Recommendation I.363: "B-ISDN ATM Adaptation Layer specification".
- [9] ISO 13818-1: "Information technology - Generic coding of moving pictures and associated audio information: Systems".
- [10] ISO/IEC 8802-3 (1996): "Information technology - Telecommunications and information exchange between systems - Local and metropolitan area networks - Specific requirements - Part 3: Carrier sense multiple access with collision detection (CSMA/CD) access method and physical layer specifications".
- [11] IETF RFC 2104, Krawczyk, et. al: "HMAC: Keyed-Hashing for Message".
- [12] IETF RFC 2236: "IGMP protocol".

- [13] IETF RFC 1483: "Multiprotocol encapsulation over ATM adapt. layer 5".
- [14] IETF RFC 2131: "Dynamic host configuration protocol (DHCP)".
- [15] IETF RFC 951: "Bootstrap protocol (BOOTP)".
- [16] IETF RFC 791: "Internet protocol".
- [17] ATM Forum UNI 3.1 ATM Forum User-Network Interface, Version 3.1.

3 Abbreviations

For the purposes of the present document, the following abbreviations apply:

ATM	Asynchronous Transfer Mode
BC	Broadcast Channel
BRA	Basic Rate Access
LMDS	Local Multipoint Distribution System
CBC	Cipher Block Chaining
Connection ID	Connection Identifier
CM	Cable Modem
D-H	Diffie-Hellman
DAVIC	Digital Audiovisual Council
DCE	Data Communication Equipment
DES	Data Encryption Standard
DTE	Data Termination Equipment
DTMF	Dual Tone Multifrequency (dialling mode)
DVB	Digital Video Broadcasting
EKE	Explicit Key Exchange
GSTN	General Switched Telephone Network
HMAC	Hash-based Message Authentication Code
IB	In-Band
IC	Interaction Channel
INA	Interactive Network Adapter
IRD	Integrated Receiver Decoder
ISDN	Integrated Services Digital Network
IQ	In-phase and Quadrature Components
IV	Initialization Vector
LFSR	Linear Feedback Shift Register
LSB	Least Significant Bit
MAC	Media Access Control
MKE	Main Key Exchange
MMDS	Multi-channel Multi-point Distribution Systems
MPEG	Moving Pictures Experts Group
MTU	Maximum Transmission Unit
NIU	Network Interface Unit
NSAP	Network Service Access Point
OOB	Out of Band
OSI	Open Systems Interconnection
PID	Packet Identifier (defined by ISO/IEC 13818 (MPEG-2) [9])
PM	Pulse Modulation
PSTN	Public Switched Telephone Network
QAM	Quadrature Amplitude Modulation
QKE	Quick Key Exchange
QoS	Quality of Service
QPSK	Quaternary Phase Shift Keying
Reservation ID	Reservation Identifier
SHA-1	Secure Hash Algorithm 1
SMATV	Satellite Master Antenna Television
STB	Set Top Box

STU	Set Top Unit
TDMA	Time Division Multiplex Access
TS	Transport Stream
VCI	ATM Virtual Channel Identification (defined by ITU-T Recommendation I.363 [8])
VPI	ATM Virtual Path Identification (defined by ITU-T Recommendation I.363 [8])

4 Reference Model for System Architecture of Narrowband Interaction Channels in a Broadcasting Scenario (Asymmetric Interactive Services)

4.1 Protocol Stack Model

For asymmetric interactive services supporting broadcast to the home with narrowband return channel, a simple communications model consists of the following layers:

physical layer: where all the physical (electrical) transmission parameters are defined.

transport layer: defines all the relevant data structures and communication protocols like data containers, etc.

application layer: is the interactive application software and runtime environments (e.g. home shopping application, script interpreter, etc.).

A simplified model of the OSI layers was adopted to facilitate the production of specifications for these nodes. Figure 1 points out the lower layers of the simplified model and identifies some of the key parameters for the lower two layers. Following the user requirements for interactive services, no attempt will be made to consider higher layers in the present document.

Layer Structure for Generic System Reference Model

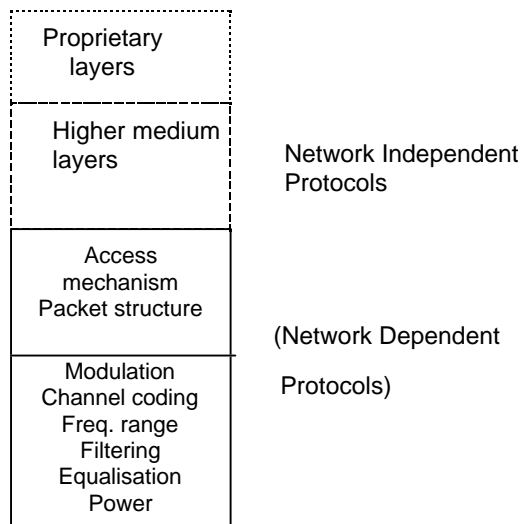

Figure 1: Layer structure for generic system reference model

This specification addresses the LMDS network specific aspects only.

4.2 System Model

Figure 2a shows the system model which is to be used within DVB for interactive services.

In the system model, two channels are established between the Service provider and the User:

- **Broadcast channel (BC):** A unidirectional broadband Broadcast Channel including video, audio and data. BC is established from the service provider to the users. It may include the Forward Interaction path.
- **Interaction channel (IC):** A Bi-directional Interaction Channel is established between the service provider and the user for interaction purposes. It is formed by:
 - **Return Interaction path:** (Return Channel): From the User to the Service Provider. It is used to make requests to the service provider or to answer questions. It is a narrowband channel. Also commonly known as return channel.
 - **Forward Interaction path:** From the service provider to the user. It is used to provide some sort of information by the service provider to the user and any other required communication for the interactive service provision. It may be embedded into the broadcast channel. It is possible that this channel is not required in some simple implementations which make use of the Broadcast Channel for the carriage of data to the user.

The user terminal is formed by the Network Interface Unit (NIU) (consisting of the Broadcast Interface Module (BIM) and the Interactive Interface Module (IIM)) and the Set Top Unit (STU). The user terminal provides interface for both broadcast and interaction channels. The interface between the user terminal and the interaction network is via the Interactive Interface Module.

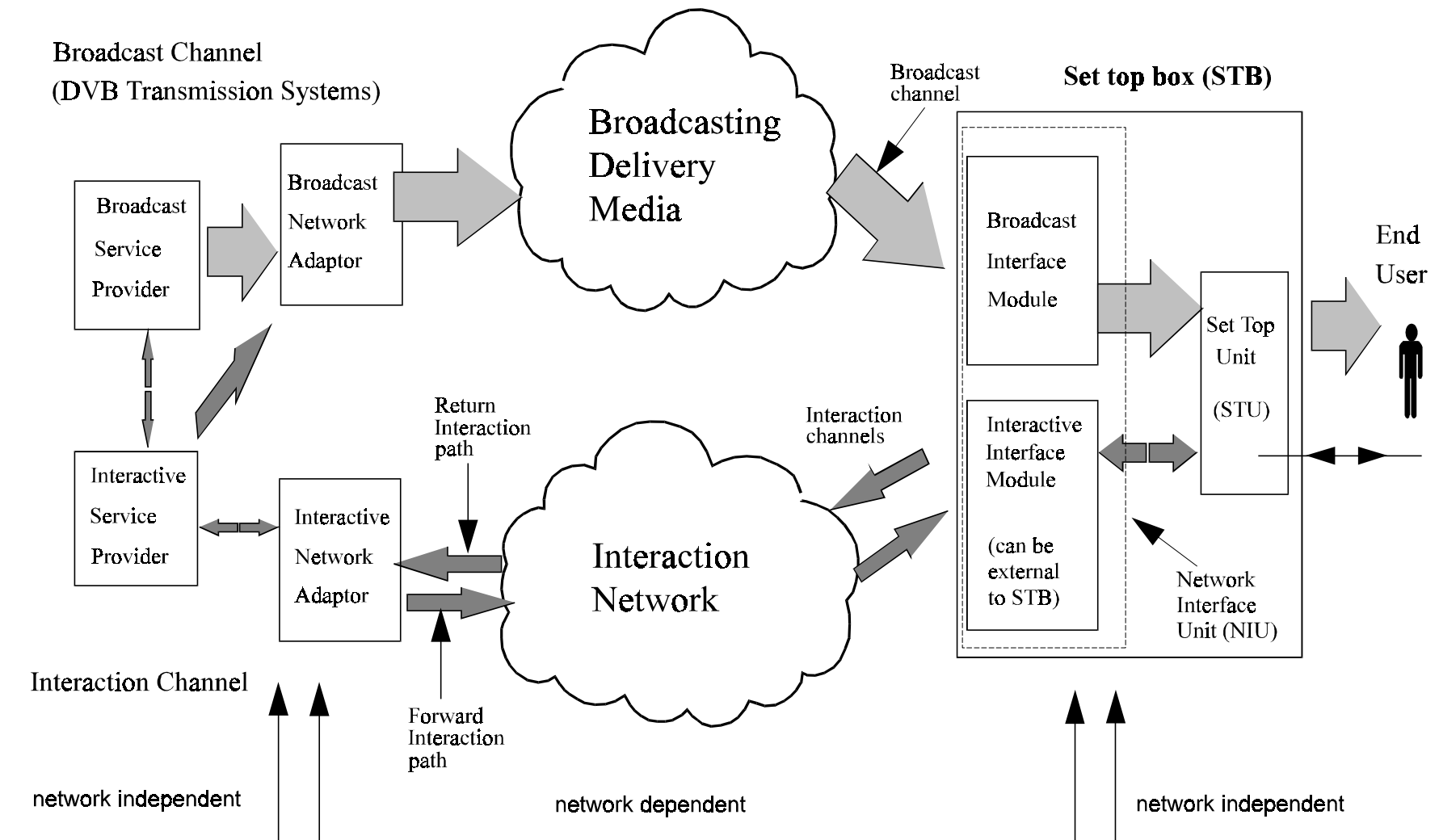
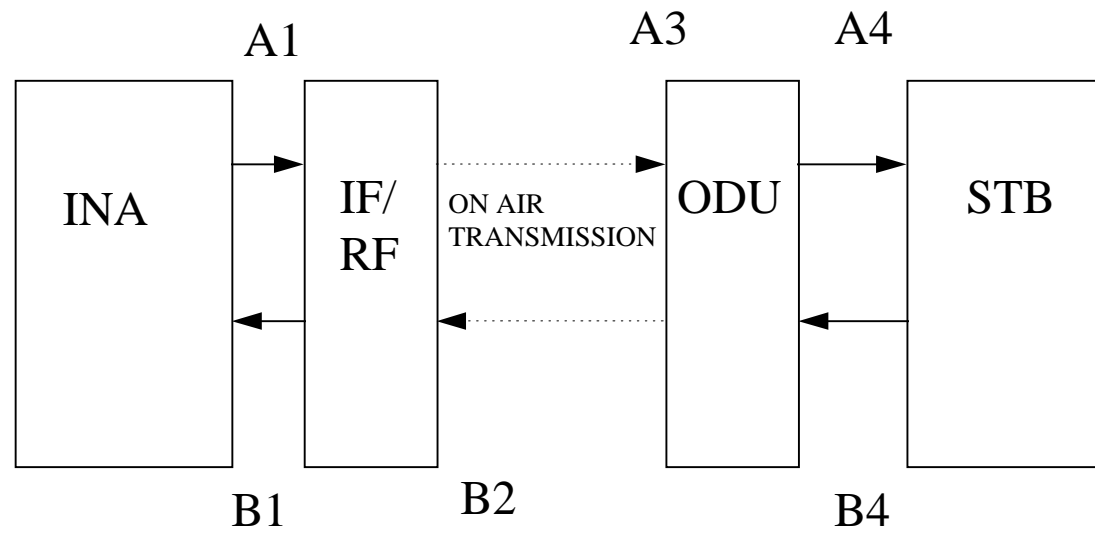

Figure 2a: A generic system Reference Model for Interactive Systems



ODU : OUTDOOR UNIT
A1, A4, B1, B4 : IF INTERFACES
B2, A3 : RF INTERFACES

Figure 2b: Position of IF and RF reference points in the particular case of LMDS networks

5 DVB Interaction Channel Specification for LMDS Networks

The LMDS infrastructures can support the implementation of the Return Channel for interactive services suitable for DVB broadcasting systems.

LMDS can be used to implement interactive services in the DVB environment, providing a bi-directional communication path between the user terminal and the service provider.

5.1 System Concept

The interactive system is composed of Forward Interaction path (downstream) and Return Interaction path (upstream). The general concept is to use downstream transmission from the INA to the NIUs to provide synchronization and information to all NIUs. This allows the NIUs to adapt to the network and send synchronized information upstream.

Upstream transmission is divided into time slots which can be used by different users, using the technique of Time Division Multiple Access (TDMA). One downstream channel is used to synchronize up to 8 upstream channels, which are all divided into time slots. A counter at the INA is sent periodically to the NIUs, so that all NIUs work with the same clock. This gives the opportunity to the INA to assign time slots to different users.

Three major access modes are provided with this system. The first one is based on contention access, which lets users send information at any time with the risk to have a collision with other user's transmissions. The second and third modes are contention-less based, where the INA either provides a finite amount of slots to a specific NIU, or a given bit rate requested by a NIU until the INA stops the connection. These access modes are dynamically shared among time slots, which allows NIUs to know when contention based transmission is or is not allowed. This is to avoid a collision for the two contention-less based access modes.

Periodically, the INA will indicate to new users that they have the possibility to go through sign-on procedure, in order to give them the opportunity to synchronize their clock to the network clock, without risking collisions with already active users. This is done by leaving a larger time interval for new users to send their information, taking into account the propagation time required from the INA to the NIUs and back.

5.1.1 Out-Of-Band / In-Band Principle

This interactive system is based either on out of band (OOB) or in-band (IB) downstream signalling. However, Set Top Boxes / Modems do not need to support both systems.

In the case of OOB signalling, a Forward Interaction path is mandatory. This path is reserved for interactivity data and control information only. However, it is also possible to send higher bit rate downstream information through a DVB-MS channel whose frequency is indicated in the forward information path.

In the case of IB signalling, the Forward Information path is embedded into the MPEG-2 TS of a DVB-MS channel. Note that it is not mandatory to include the Forward Information path in all DVB-MS channels.

Both systems can provide the same quality of service. However, the overall system architecture will differ between networks using IB Set Top Boxes / Modems and OOB Set Top Boxes / Modems. Note also that both types of systems may exist on the same networks under the condition that different frequencies are used for each system.

5.1.2 Spectrum Allocation

The RF spectrum allocation is still to be defined and approved by the regulation bodies; the following IF frequency ranges to use are not mandatory.

For downstream, both in Band and Out Of Band channels can use the 950 to 2 150 MHz frequency band.

For upstream channels two different choices can be identified:

- 1) For the OOB signalling, In order to keep compatibility with equipment used in existing cable networks in accordance with the ETS 300 800 [2] specification, 70 to 130 MHz and 5 to 65 MHz can be used for downstream and upstream respectively.
- 2) For the IB signalling, taking into account the backward compatibility with the cable specifications and in order to give major capacity for the future interactive and multimedia services, the frequency allocation can be 400 to 700 MHz is 5 to 305 MHz. Figure 3c indicates a possible spectrum allocation. Although not mandatory, a guideline is provided to use the following preferred frequency ranges, 70 to 130 MHz and/or 950 to 2 150 for the Forward Interaction path (downstream OOB) and 5 to 65 MHz for the Return Interaction path (upstream), or parts thereof. To avoid filtering problems in the bi-directional video amplifiers and in the Set Top Boxes, the upper limit 65 MHz for the upstream flow shall not be used together with the lower limit 70 MHz for the downstream flow in the same system.

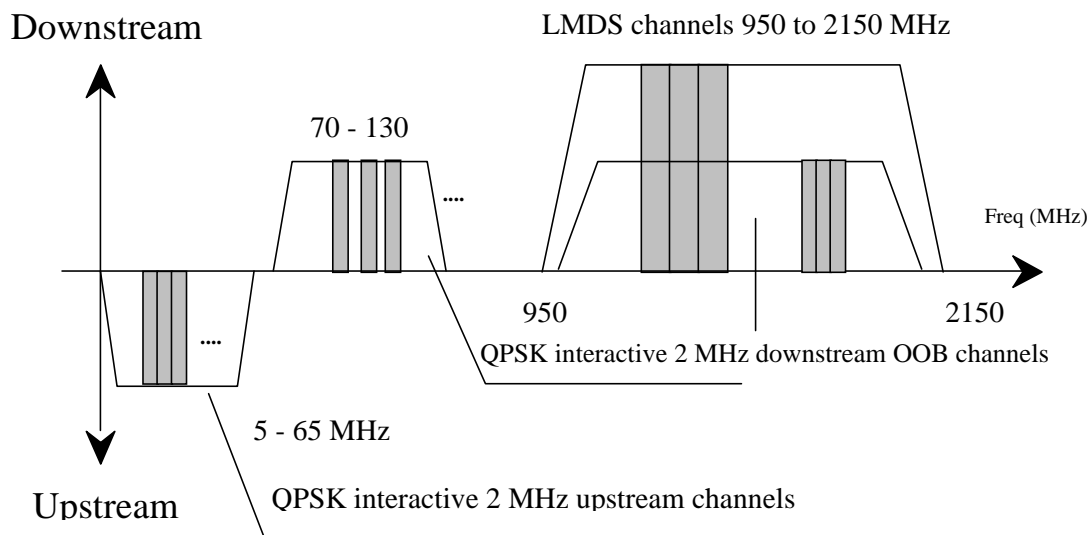

Figure 3a: DVB preferred IF frequency ranges for LMDS interactive systems (OOB)

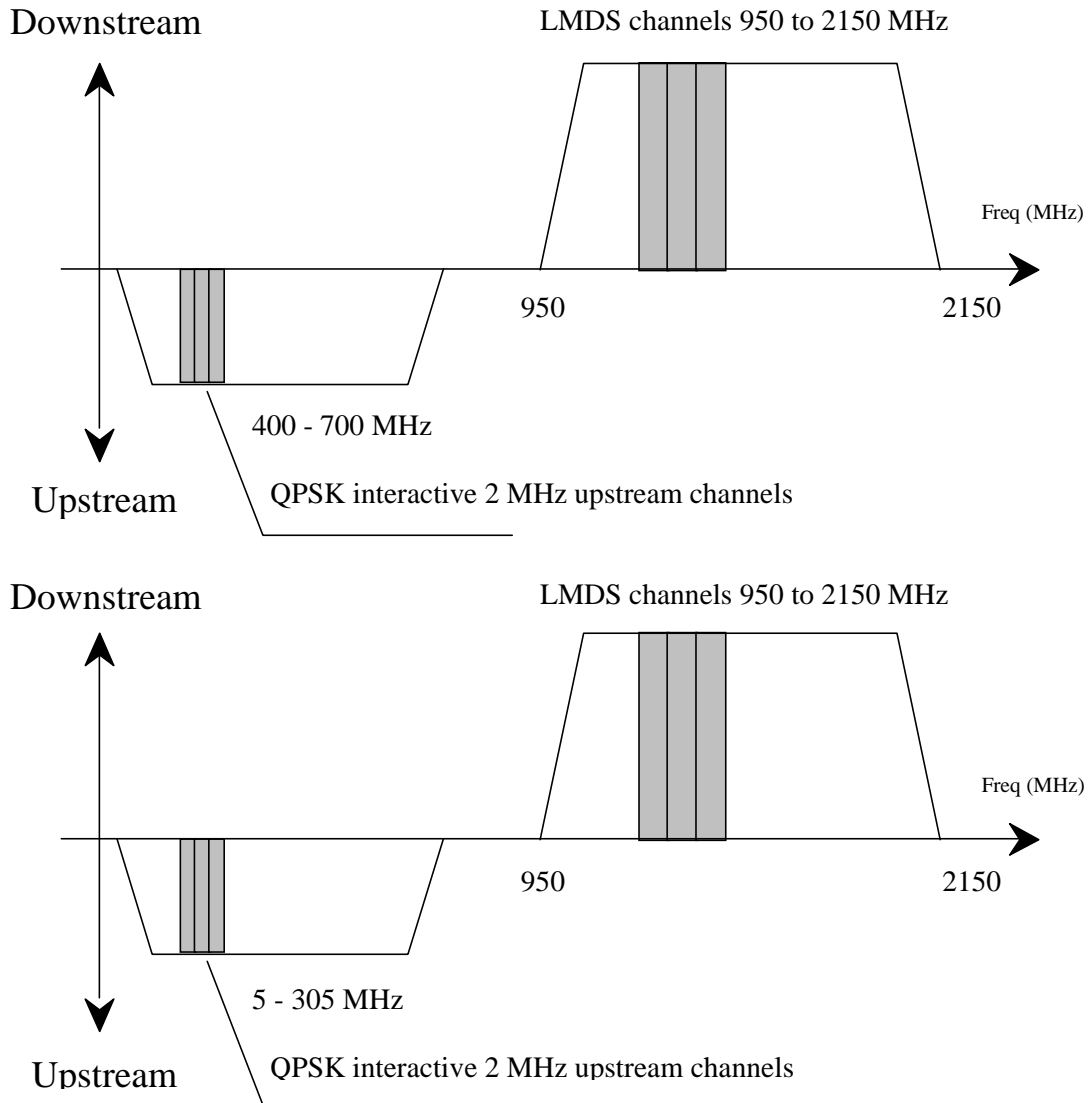

Figure 3b: DVB preferred IF frequency ranges for LMDS interactive systems (IB)

NOTE: The standard is applicable to any RF frequency range, according to local regulations. therefore, the frequencies specified in the present document are in the intermediate frequency range.

5.1.3 FDMA/TDMA Multiple Access

A multiple access scheme is defined in order to have different users share the same transmission media. Downstream information is sent broadcast to all users of the networks. Thus, an address assignment exists for each user which allows the INA to send information singlecast to one particular user. Two addresses are stored in the Set Top Boxes / Modems in order to identify users on the network:

MAC address: It is a 48-bit value representing the unique MAC address of the NIU. This MAC address may be hard coded in the NIU or be provided by external source.

NSAP address: It is a 160-bit value representing a network address. This address is provided by higher layers during communication.

Upstream information may come from any user in the network and shall therefore also be differentiated at the INA using the set of addresses defined above.

Upstream and OOB downstream channels are divided into separate channels of 2 MHz bandwidth for downstream and 2 or 4 MHz for upstream. Each downstream channel contains a synchronization frame used by up to 8 different upstream channels, whose frequencies are indicated by the Media Access Control (MAC) protocol.

Within upstream channels, users send packets with TDMA type access. This means that each channel is shared by many different users, who can either send packets with a possibility of collisions when this is allowed by the INA, or request transmission and use the packets assigned by the INA to each user specifically. Assuming each channel can therefore accommodate thousands of users at the same time, the upstream bandwidth can easily be used by all users present on the network at the same time.

The TDMA technique utilizes a slotting methodology which allows the transmit start times to be synchronized to a common clock source. Synchronizing the start times increases message throughput of this signalling channel since the message packets do not overlap during transmission. The period between sequential start times are identified as slots. Each slot is a point in time when a message packet can be transmitted over the signalling link.

The time reference for slot location is received via the downstream channels generated at the Delivery System and received simultaneously by all set-top units. Note that this time reference is not sent in the same way for OOB and IB signalling. Since all NIU's reference the same time base, the slot times are aligned for all NIU's. However, since there is propagation delay in any transmission network, a time base ranging method accommodates deviation of transmission due to propagation delay.

Since the TDMA signalling link is used by NIUs that are engaged in interactive sessions, the number of available message slots on this channel is dependent on the number of simultaneous users. When messaging slots are not in use, an NIU may be assigned multiple message slots for increased messaging throughput. Additional slot assignments are provided to the NIU from the downstream signalling information flow.

There are different access modes for the upstream slots:

- reserved slots with fixed rate reservation (Fixed rate Access: the user has a reservation of one or several timeslots in each frame enabling, e.g. for voice, audio);
- reserved slots with dynamic reservation (Reservation Access: the user sends control information announcing his demand for transmission capacity. He gets grants for the use of slots);
- contention based slots (these slots are accessible for every user. Collision is possible and solved by a contention resolution protocol);
- ranging slots (these slots are used upstream to measure and adjust the time delay and the power).

These slots may be mixed on a single carrier to enable different services on one carrier only. If one carrier is assigned to one specific service, only those slot types will be used which are needed for this service.

5.1.4 Bit Rates and Framing

For the interactive downstream OOB channel, a transmission bit rate of 3,088 Mbit/s shall be used. The support of 3,088 Mbit/s is mandatory for both INA and NIU. For downstream IB channels, no other constraints than those specified in the DVB-MS specifications exist, but a guideline is to use rates multiples of 8 kbit/s.

Downstream OOB channels continuously transmit a frame based on T1 type framing, in which some information is provided for synchronization of upstream slots. Downstream IB channels transmit some MPEG-2 TS packets with a specific PID for synchronization of upstream slots (at least one packet containing synchronization information shall be sent in every period of 3 ms).

For upstream transmission, the INA can indicate two types of transmission rates to users, specifically 6,176 Mbit/s and 3,088 Mbit/s. The support of 3,088 Mbit/s is mandatory, of other rates is optional for both INA and NIU. The INA is responsible of indicating which rate may be used by NIUs.

Upstream framing consists of packets of 512 bits (256 symbols) which are sent in a bursty mode from the different users present on the network. The upstream slot rates are 12 000 upstream slots when the upstream transmission bit rate is 6,176 Mbit/s, 6 000 upstream slots/s when the upstream transmission bit rate is 3,088 Mbit/s.

5.2 Lower Physical Layer Specification

In this subclause, detailed information is given on the lower physical layer specification. Figure 3c and Figure 4 show the conceptual block diagrams for implementation of the present specification.

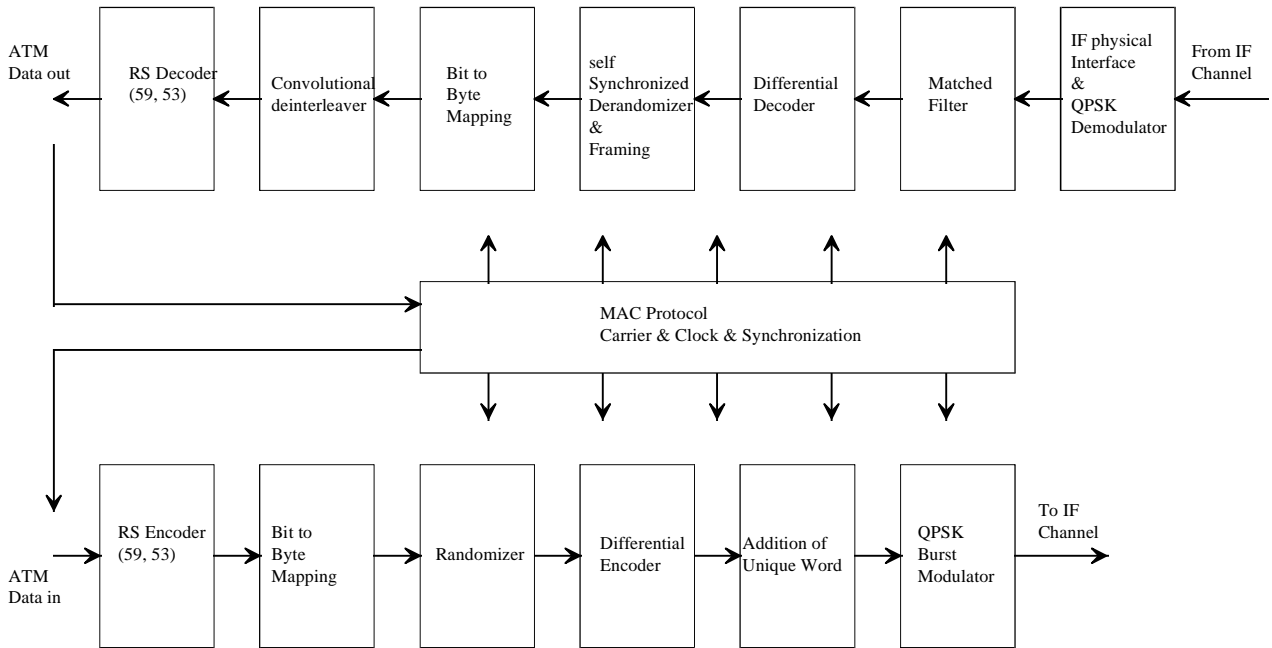

Figure 3c: Conceptual Block Diagram for the NIU OOB Transceiver

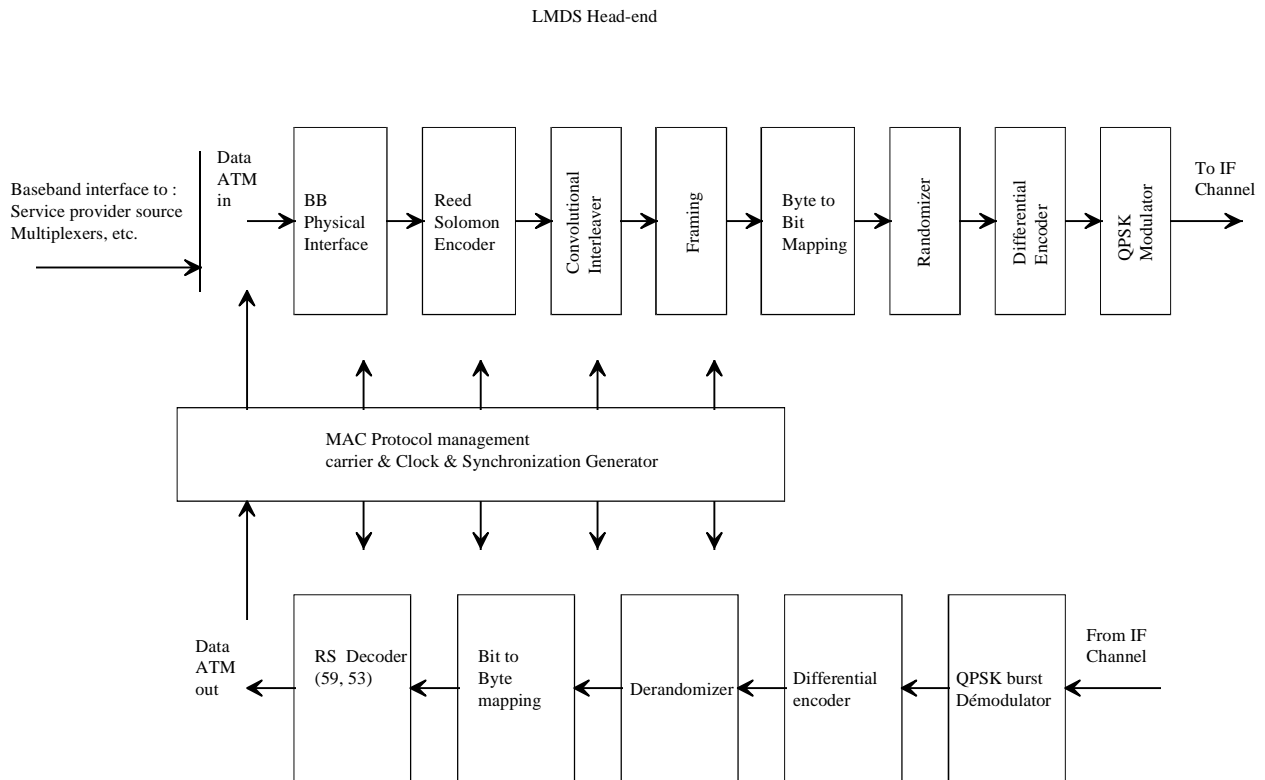

Figure 4: Conceptual Block Diagram for the OOB Head-End Transceiver

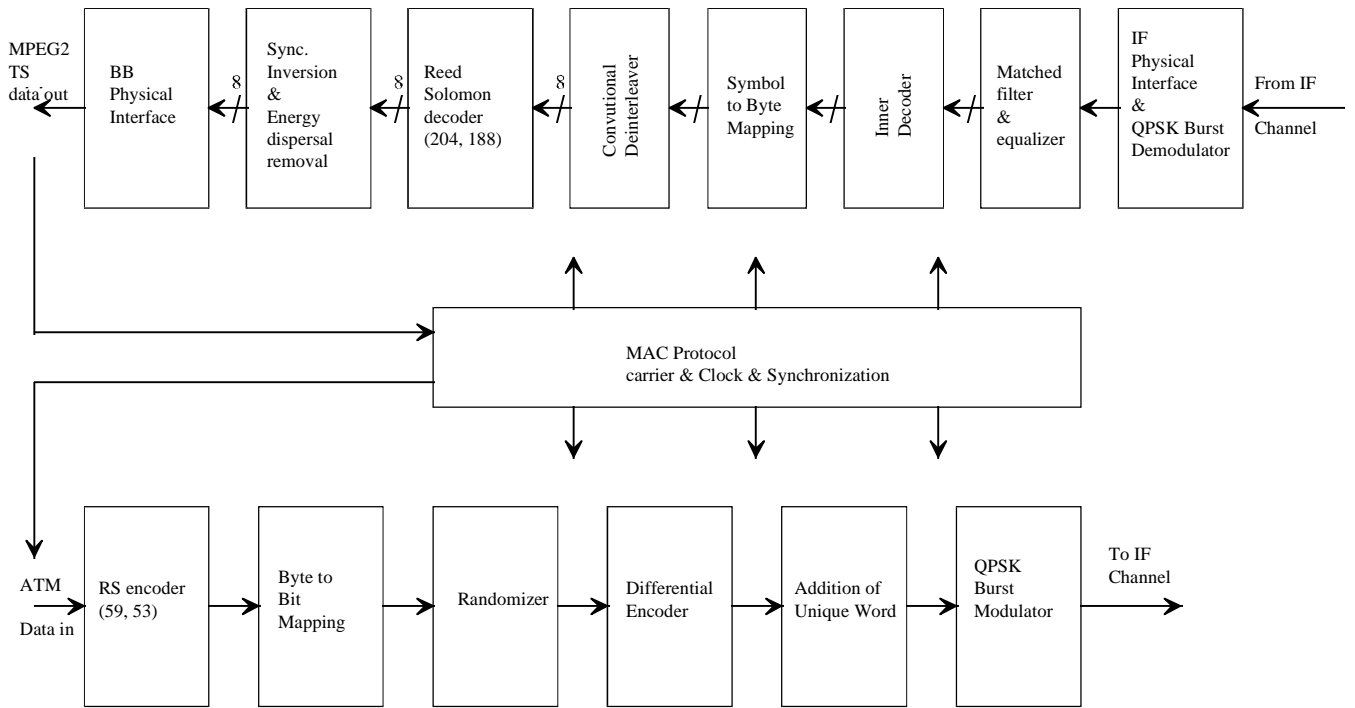

Figure 5: Conceptual Block Diagram for the IB NIU Transceiver

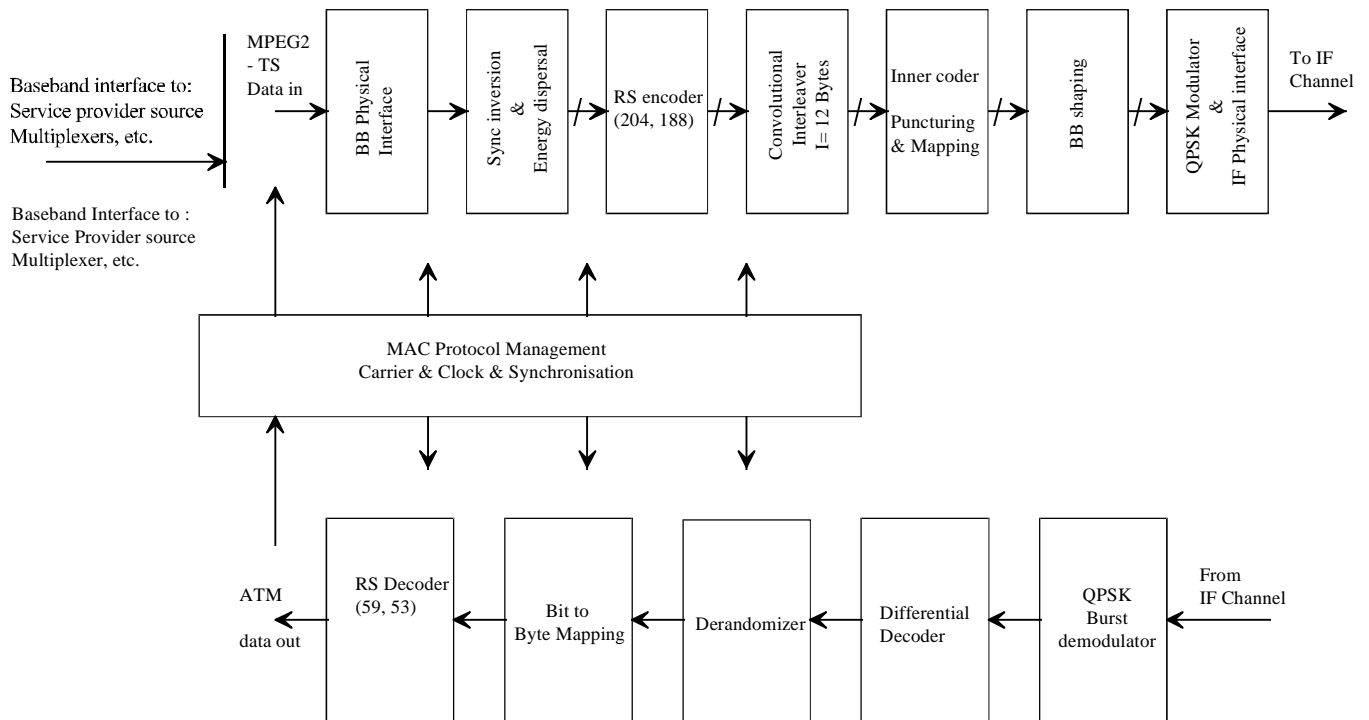

Figure 6: Conceptual Block Diagram for the IB Head-End Transceiver

5.2.1 Forward Interaction Path (Downstream OOB)

5.2.1.1 Frequency Range (Downstream OOB)

See subclause 5.1.2.

5.2.1.2 Modulation and Mapping (Downstream OOB)

QPSK modulation is used as a means of encoding digital information over wireline or fibre transmission links. The method is a subset of Phase Shift Keying (PSK) which is a subset of Phase Modulation (PM). Specifically QPSK is a four level use of digital phase modulation (PM). Quadrature signal representations involve expressing an arbitrary phase sinusoidal waveform as a linear combination of a cosine wave and a sine wave with zero starting phases.

QPSK systems require the use of differential encoding and corresponding differential detection. This is a result of the receivers having no method of determining if a recovered reference is a sine reference or a cosine reference. In addition, the polarity of the recovered reference is uncertain.

Differential encoding transmits the information in encoded phase differences between the two successive signals. The modulator processes the digital binary symbols to achieve differential encoding and then transmits the absolute phases. The differential encoding is implemented at the digital level.

The differential encoder shall accept bits A, B in sequence, and generate phase changes as follows:

Table 1: Phase changes associated with bit A, B

A	B	Phase Change
0	0	none
0	1	+90°
1	1	180°
1	0	-90°

In serial mode, A arrives first. The outputs I, Q from the differential encoder map to the phase states as in Figure 7.

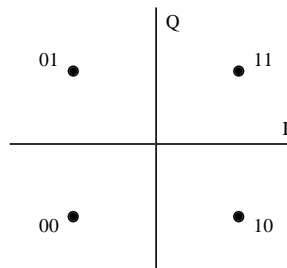

Figure 7: Mapping for the QPSK constellation (downstream OOB)

The phase changes can also be expressed by the following formulas (assuming the constellation is mapped from I and Q as shown in 5.2.2.2):

$$\begin{cases} A_k = \overline{(I_{k-1} \oplus Q_{k-1})} \times (Q_{k-1} \oplus Q_k) + \overline{(I_k \oplus Q_{k-1})} \times (I_k \oplus I_{k-1}) \\ B_k = \overline{(I_{k-1} \oplus Q_{k-1})} \times (I_{k-1} \oplus I_k) + \overline{(I_{k-1} \oplus Q_k)} \times (Q_k \oplus Q_{k-1}) \end{cases},$$

where k is the time index.

I/Q amplitude imbalance shall be less than 1,0 dB, and phase imbalance less than 2,0°.

5.2.1.3 Shaping Filter (Downstream OOB)

The time-domain response of a square-root raised-cosine pulse with excess bandwidth parameter α is given by:

$$g(t) = \frac{\sin\left[\frac{\pi t}{T}(1-\alpha)\right] + \frac{4\alpha t}{T} \cos\left[\frac{\pi t}{T}(1+\alpha)\right]}{\frac{\pi t}{T} \left[1 - \left(\frac{4\alpha t}{T}\right)^2\right]}$$

where T is the symbol period.

The output signal shall be defined as:

$$S(t) = \sum_n [I_n \times g(t - nT) \times \cos(2\pi f_c t) - Q_n \times g(t - nT) \times \sin(2\pi f_c t)]$$

with I_n and Q_n equal to ± 1 , independently from each other, and f_c the QPSK modulator's carrier frequency.

The QPSK modulator divides the incoming bit stream so that bits are sent alternately to the in-phase modulator I and the out-of-phase modulator Q. These same bit streams appear at the output of the respective phase detectors in the demodulator where they are interleaved back into a serial bit stream.

The occupied bandwidth of a QPSK signal is given by the equation:

$$\text{Bandwidth} = \frac{f_b}{2} (1 + \alpha)$$

f_b = bit rate

α = excess bandwidth = 0,30

The Power Spectrum at the QPSK transmitter shall comply to the Power Spectrum Mask given in Table 2 and Figure 8. The Power Spectrum Mask shall be applied symmetrically around the carrier frequency.

Table 2: QPSK Downstream Transmitter Power Spectrum

$ (f - f_c) / f_N $	Power Spectrum
$\leq 1 - \alpha$	$0 \pm 0,25$ dB
at 1	$-3 \pm 0,25$ dB
at $1 + \alpha$	≤ -21 dB
≥ 2	≤ -40 dB

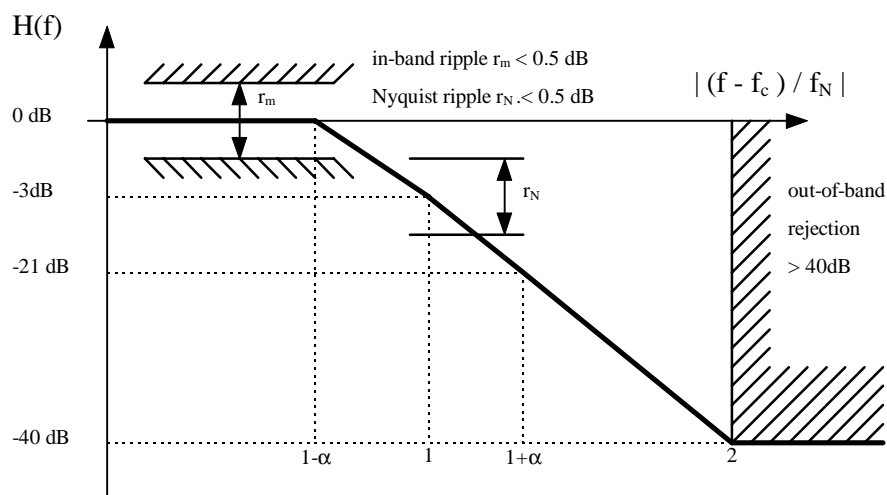

Figure 8: QPSK Downstream Transmitter Power Spectrum

QPSK systems require the use of differential encoding and corresponding differential detection. This is a result of the receivers having no method of determining if a recovered reference is a sine reference or a cosine reference. In addition, the polarity of the recovered reference is uncertain.

Differential encoding transmits the information in encoded phase differences between the two successive signals. The modulator processes the digital binary symbols to achieve differential encoding and then transmits the absolute phases. The differential encoding is implemented at the digital level.

5.2.1.4 Randomizer (Downstream OOB)

After addition of the FEC bytes (see subclause 5.3.1), all of the 3,088 Mbit/s data is passed through a six register linear feedback shift register (LFSR) randomizer to ensure a random distribution of ones and zeroes. The output of the randomizer shall be the quotient of the input data multiplied by x^6 and then divided by the generator polynomial $x^6 + x^5 + 1$. Byte/serial conversion shall be MSB first. A complementary self-synchronizing de-randomizer is used in the receiver to recover the data.

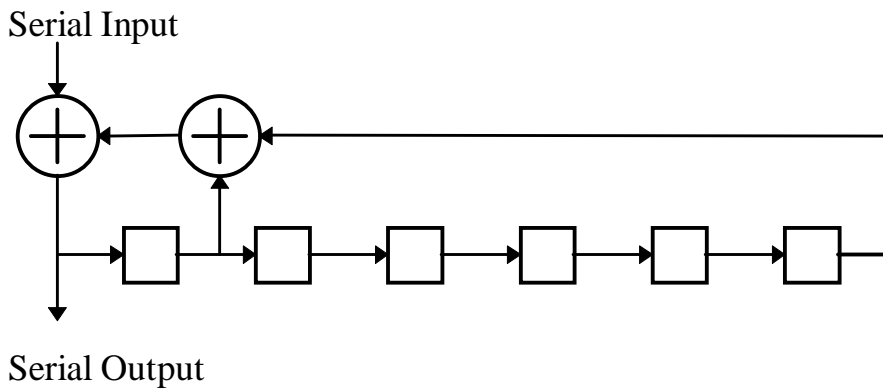

Figure 9: Example Randomizer

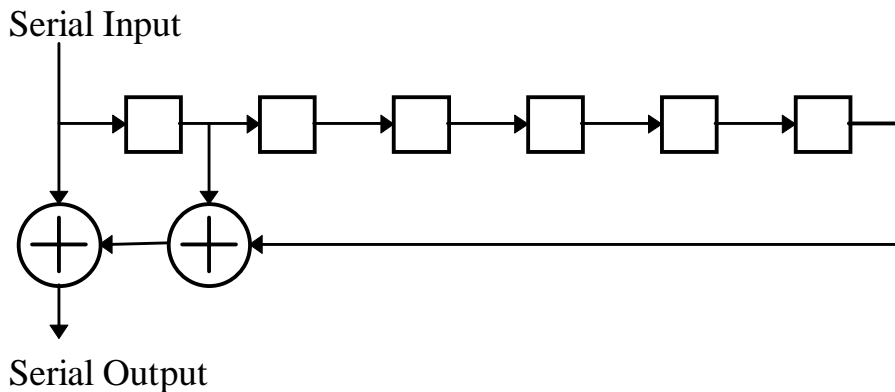

Figure 10: Example De-randomizer

5.2.1.5 Bit Rate (Downstream OOB)

The bit rate shall be 3,088 Mbit/s. The support of 3,088 Mbit/s is mandatory for both INA and NIU. Symbol rate accuracy should be within ± 50 ppm.

5.2.1.6 Receiver Power Level (Downstream OOB) (informative)

The receiver power level shall be in the range 42 to 75 dB μ V (RMS) (75 Ω) at its input.

5.2.1.7 Summary (Downstream OOB)

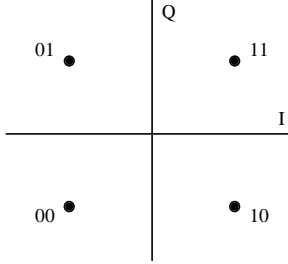
Transmission Rate	3,088 Mbit/s for Grade B (mandatory for INA and NIU)
Modulation	Differentially encoded QPSK.
Transmit Filtering	Filtering is alpha = 0,30 square root raised cosine
Channel Spacing	2 MHz for Grade B
Frequency Step Size	250 kHz (centre frequency granularity)
Randomization	After addition of the FEC bytes, all of the 3,088 Mbit/s data is passed through a six register linear feedback shift register (LFSR) randomizer to ensure a random distribution of ones and zeroes. The generating polynomial is: $x^6 + x^5 + 1$. Byte/serial conversion shall be MSB first. A complementary self-synchronizing de-randomizer is used in the receiver to recover the data.
Differential Encoding	The differential encoder shall accept bits A, B in sequence, and generate phase changes as follows: <u>A B Phase Change</u> 0 0 none 0 1 +90° 1 1 180° 1 0 -90° In serial mode, A arrives first.
System Phase Noise max.: (phase noise includes both IF and RF parts).	-41 dBc/Hz at 1 kHz -71 dBc/Hz at 10 kHz -92 dBc/Hz at 100 kHz
Signal Constellation	The outputs I, Q from the differential encoder map to the phase states as in Figure 11.  <p style="text-align: center;">Figure 11: QPSK Constellation</p>
IF Frequency Range (informative)	950 to 2 150 MHz or 70 to 130 MHz recommended but not mandatory 70 to 130 MHz and/or 300 to 862 MHz
Symbol Rate Accuracy	± 50 ppm
Carrier Suppression	> 30 dB
I/Q Amplitude Imbalance	< 1,0 dB
I/Q Phase Imbalance	< 2,0°
Receive Power Level at the NIU input (informative)	42 to 75 dBμV (RMS) (75 Ω)
Transmit Spectral Mask	A common mask is given in Table 2 and Figure 8.
RF Interface A3 Frequency uncertainty	± 200 kHz
IF interface A4 frequency uncertainty	± 5 MHz

5.2.1.8 Bit Error Rate Downstream OOB (Informative)

To be defined.

5.2.2 Forward Interaction Path (Downstream IB)

The IB Forward Interaction Path shall use a MPEG-2 TS stream with a modulated QPSK channel as defined by EN 300 421 [4]. Frequency range, channel spacing, and other lower physical layer parameters should follow that specification. The accuracy of the downstream RF frequency shall be better than ± 5 MHz.

5.2.3 Return Interaction Path (Upstream)

5.2.3.1 Frequency Range (Upstream)

See subclause 5.1.2.

5.2.3.2 Modulation and Mapping (Upstream)

The unique word (0X 00 FC FC F3, see subclause 5.3.3 for upstream framing) is not differentially encoded, the outputs I, Q map to the phase states as in Figure 12.

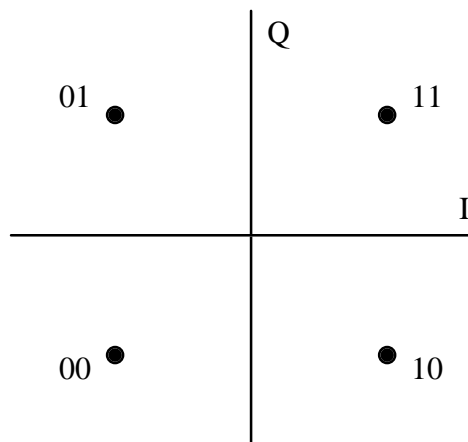

Figure 12: Mapping for the QPSK constellation (upstream)

For the remainder of the packet, the differential encoder shall accept bits A, B in sequence, and generate phase changes as follows. It starts with the first information digit and is initialized with the last digit of the unique word, i.e. (A,B = 0,1) since conversion is made MSB first.

Table 3: Phase Changes Corresponding to Bits A, B

A	B	Phase Change
0	0	none
0	1	+90°
1	1	180°
1	0	-90°

Phase changes correspond to the following formulas (assuming I and Q are mapped to the constellation as for the unique word):

$$\begin{cases} A_k = (\overline{I_{k-1} \oplus Q_{k-1}}) \times (Q_{k-1} \oplus Q_k) + (\overline{I_k \oplus Q_{k-1}}) \times (I_k \oplus I_{k-1}) \\ B_k = (\overline{I_{k-1} \oplus Q_{k-1}}) \times (I_{k-1} \oplus I_k) + (\overline{I_{k-1} \oplus Q_k}) \times (Q_k \oplus Q_{k-1}) \end{cases}$$

where k is the time index.

I/Q amplitude imbalance shall be less than 1,0 dB, and phase imbalance less than 2,0°.

5.2.3.3 Shaping Filter (Upstream)

The time-domain response of a square-root raised-cosine pulse with excess bandwidth parameter α is given by:

$$g(t) = \frac{\sin\left[\frac{\pi t}{T}(1-\alpha)\right] + \frac{4\alpha t}{T} \cos\left[\frac{\pi t}{T}(1+\alpha)\right]}{\frac{\pi t}{T} \left[1 - \left(\frac{4\alpha t}{T}\right)^2\right]}$$

where T is the symbol period.

The output signal shall be defined as:

$$S(t) = \sum_n [I_n \times g(t - nT) \times \cos(2\pi f_c t) - Q_n \times g(t - nT) \times \sin(2\pi f_c t)]$$

with I_n and Q_n equal to ± 1 , independently from each other, and f_c the QPSK modulator's carrier frequency.

The QPSK modulator divides the incoming bit stream so that bits are sent alternately to the in-phase modulator I and the out-of-phase modulator Q. These same bit streams appear at the output of the respective phase detectors in the demodulator where they are interleaved back into a serial bit stream.

The QPSK signal parameters are:

RF bandwidth	$BW = (f_b / 2) * (1 + \alpha)$
Occupied RF Spectrum	$[f_c - BW/2, f_c + BW/2]$
Symbol Rate	$f_s = f_b / 2$
Nyquist Frequency	$f_N = f_s / 2$

with f_b = bit rate, f_c = carrier frequency and α = excess bandwidth.

For all bit rates: 3,088 Mbit/s (Grade C) and 6,176 Mbit/s (Grade D), the Power Spectrum at the QPSK transmitter shall comply to the Power Spectrum Mask given in Table 4 and Figure 13. The Power Spectrum Mask shall be applied symmetrically around the carrier frequency.

Table 4: QPSK Upstream Transmitter Power Spectrum

$ (f - f_c) / f_N $	Power Spectrum
$\leq 1 - \alpha$	$0 \pm 0,25$ dB
at 1	$-3 \pm 0,25$ dB
at $1 + \alpha$	≤ -21 dB
≥ 2	≤ -40 dB

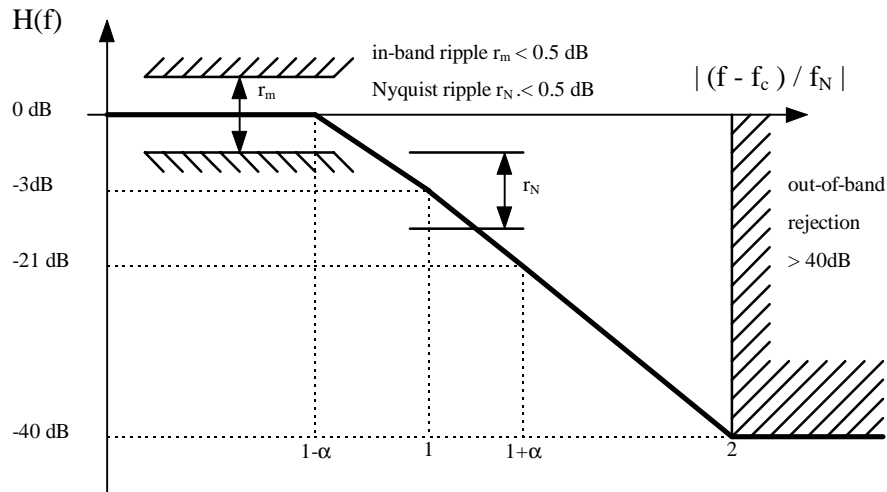

Figure 13: QPSK Upstream Transmitter Power Spectrum

The specifications which shall apply to HtmlResAnchor QPSK modulation for the upstream channel are given in Table 4.

5.2.3.4 Randomizer (Upstream)

The unique word shall be sent in clear (see subclause 5.3.3). After addition of the FEC bytes, randomization shall apply only to the payload area and FEC bytes, with the randomizer performing modulo-2 addition of the data with a pseudo-random sequence. The generating polynomial is $x^6 + x^5 + 1$ with seed all ones. We assume the first value coming out of the pseudo-random generator taken into account is 0. Byte/serial conversion shall be MSB first. The binary sequence generated by the shift register starts with 00000100... The first "0" is to be added in the first bit after the unique word.

A complementary non self-synchronizing de-randomizer is used in the receiver to recover the data. The de-randomizer shall be enabled after detection of the unique word.

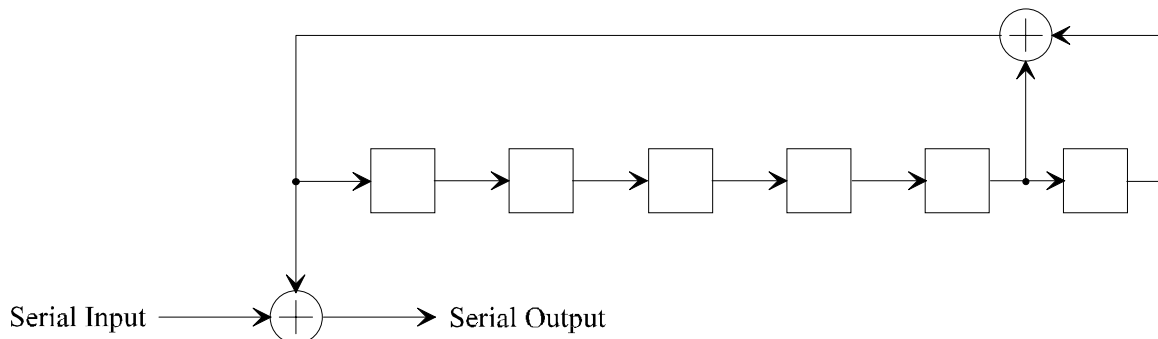

Figure 14: Randomizer

5.2.3.5 Bit Rate (Upstream)

Two grades of modulation transmission rate are specified; they are called C and D for compatibility with ETS 300 800 [2].

Table 5: Upstream bit-rates for modulation grades C and D

Grade	Rate
C	3,088 Mbit/s (mandatory for INA and NIU)
D	6,176 Mbit/s (optional for INA and NIU)

The support of 3,088 Mbit/s is mandatory, of other rates is optional for both INA and NIU.

Symbol rate accuracy should be within ± 50 ppm.

For grade C, the rate is 6 000 slots/s. For grade D, the rate is 12 000 slots/s.

5.2.3.6 Transmit Power Level (Upstream) (informative)

At the output, the transmit power level shall be in the range 85 to 113 dB μ V (RMS) (75 Ω). This power shall be adjustable by steps of 0,5 dB (nominally) by MAC messages coming from the INA.

Measured at the INA, the US power accuracy shall be better or equal to $\pm 1,5$ dB.

5.2.3.7 Upstream Burst Power and Timing Profiles

Because of the symbol shaping filter that spreads the symbol duration over $T_s = 1/\text{symbol_rate}$, a burst has a ramp up (before the first symbol) and a ramp down (after the last symbol) as shown Figure 15.

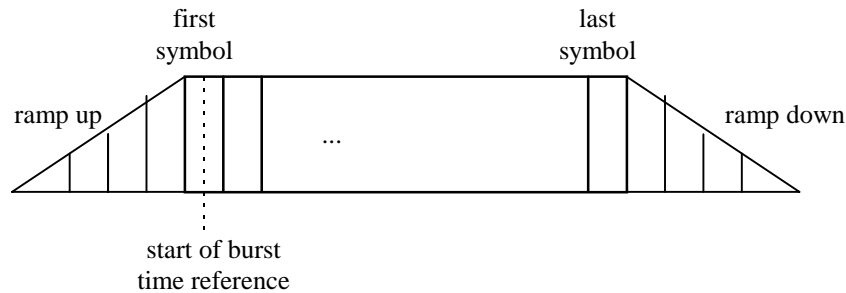

Figure 15: Burst Ramp Up and Down

The ramps up and down of consecutive bursts can overlap.

The ramps shall be minimum 3 symbols long.

When the transmitter is idle the upstream power level attenuation shall be more than 60 dB (relative to the nominal burst power output level), over the entire power output. A terminal is considered to be idle if it is 3 slots before an imminent transmission or 3 slots after its most recent transmission.

4 symbols before the first symbol of a burst and 4 symbols after the last symbol, the upstream power level attenuation shall be more than 30 dB (relative to the nominal burst power output level), over the entire power output range.

After ranging and propagation delay compensation, the NIU/STB US timing accuracy shall be better than or equal to $\pm 5/8$ th of a symbol (Upstream rate).

The time ranging accuracy provided by the MAC messages coming from the INA shall be better than or equal to $\pm 1/8$ th of a symbol (Upstream rate).

The NIU messages shall then arrived at the INA in a window of $\pm 0,75$ symbols (Upstream transmission bit rate).

5.2.3.8 Interference (Spurious) Suppression

The noise and the spurious power at the output of the transmitting (upstream) device may not exceed the levels as shown in Table 6 below. The measurement bandwidth is equal to the symbol rate.

Table 6: Interference Spurious Suppression

	Transmitting burst	Between bursts
In band	n.a.	- 60 dBc (see notes 1 and 2)
Adjacent band upstream	- 40 dBc	- 70 dBc (see notes 1 and 2)
NOTE 1: dBc is based on the carrier level during the burst.		
NOTE 2: The additional suppression of 30 dB for inter burst is based on the connection max. 1 000 NIU's per INA.		

5.2.3.9 Summary (Upstream)

Table 7: Summary (Upstream)

Upstream Transmission Bit Rate	Two grades of modulation transmission bit rate are specified: Grade Rate C 3,088 Mbit/s (mandatory for INA and NIU) D 6,176 Mbit/s (optional for INA and NIU) The support of 3,088 Mbit/s is mandatory, of other rates is optional for both INA and NIU.
Modulation	Differentially encoded QPSK
Transmit Filtering	alpha = 0,30 square root raised cosine
Channel Spacing	2 MHz for Grade C (3,088 Mbit/s) 4 MHz for Grade D (6,176 Mbit/s)
Frequency Step Size	50 kHz
Randomization	The unique word shall be sent in the clear. After addition of the FEC bytes, randomization shall apply only to the payload area and FEC bytes, with the randomizer performing modulo-2 addition of the data with a pseudo-random sequence. The generating polynomial is $x^6 + x^5 + 1$ with seed all ones. Byte/serial conversion shall be MSB first. A complementary non self-synchronizing de-randomizer is used in the receiver to recover the data. The de-randomizer shall be enabled after detection of the unique word.
Differential Encoding	The differential encoder shall accept bits A, B in sequence, and generate phase changes as follows. In serial mode, A arrives first. A B Phase Change 0 0 none 0 1 +90° 1 1 180° 1 0 -90°
Signal Constellation (see note)	The outputs I, Q from the differential encoder map to the phase states as in Figure 16. 
IF Frequency Range (informative)	5 to 65 MHz or 400 to 700 MHz
IF Frequency Stability	± 50 ppm measured at the upper limit of the frequency range
Symbol Rate Accuracy	± 50 ppm
Transmit Spectral Mask	A common mask is given in Table 4 and Figure 13.
Carrier Suppression when Transmitter Active	> 30 dB

Figure 16: Burst QPSK Constellation

Burst Power Profile	<p>Upstream power level attenuation shall be more than 60 dB relative to the nominal burst power output level over the entire power output range and 30 dB right after or before transmission.</p> <p>Idle Transmitter Definition: A terminal is considered to be idle if it is 3 slots before an imminent transmission or 3 slots after its most recent transmission.</p> 
I/Q Amplitude Imbalance	< 1,0 dB
I/Q Phase Imbalance	< 2,0°
Transmit Power Level at the modulator output (upstream) (informative)	85 to 113 dBμV (RMS) (75 Ω)
RF interface B3 frequency accuracy	± 100 kHz
IF interface B1 frequency accuracy	± 200 kHz
NOTE: The unique word (0x 00 FC FC F3) does not go through differential encoding.	

5.2.3.10 Packet Loss Upstream (Informative)

To be defined.

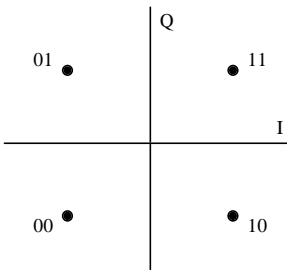
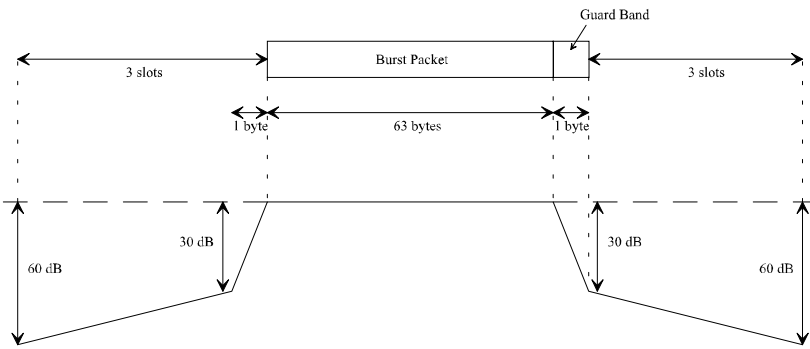
5.2.3.11 Maximum Delay

This specification has been designed to support round trip delays of up to 800 μs, which corresponds to a distance of approximately 80 km. Larger delays than this may be accommodated, with judicious use of the specification.

5.3 Framing

5.3.1 Forward Interaction Path (Downstream OOB)

5.3.1.1 Signalling Link Extended Superframe Framing Format

The Signalling Link Extended Superframe (SL-ESF) frame structure is shown in Figure 17. The bitstream is partitioned into 4 632-bit Extended Superframes. Each Extended Superframe consists of 24×193 -bit frames. Each frame consists of 1 overhead (OH) bit and 24 bytes (192 bits) of payload.

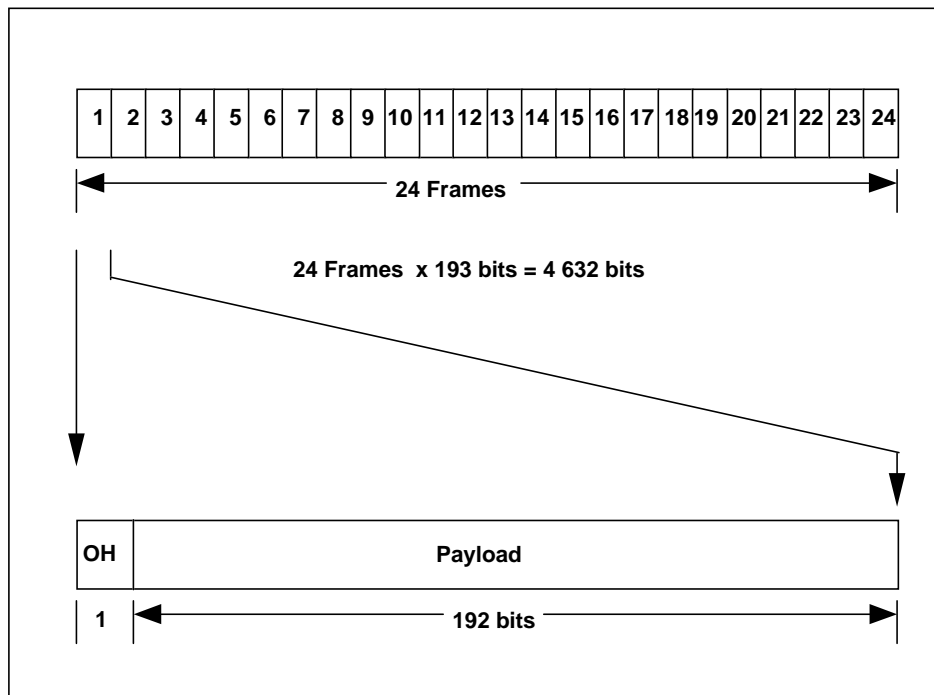

Figure 17: SL-ESF Frame Structure

5.3.1.2 Frame overhead

There are 24 frame overhead bits in the Extended Superframe which are divided into Extended Superframe Frame Alignment Signal (F1-F6), Cyclic Redundancy Check (C1-C6), and M-bit Data Link (M1-M12) as shown in Table 8. Bit number 0 is received first.

Table 8: Frame overhead

Frame Number	Bit Number	Overhead Bit	Data (192 bits)
1	0	M1	
2	193	C1	
3	386	M2	
4	579	F1 = 0	
5	772	M3	
6	965	C2	
7	1 158	M4	
8	1 351	F2 = 0	
9	1 544	M5	
10	1 737	C3	
11	1 930	M6	
12	2 123	F3 = 1	
13	2 316	M7	
14	2 509	C4	
15	2 702	M8	
16	2 895	F4 = 0	
17	3 088	M9	
18	3 281	C5	
19	3 474	M10	
20	3 667	F5 = 1	
21	3 860	M11	
22	4 053	C6	
23	4 246	M12	
24	4 439	F6 = 1	

FAS: Frame Alignment Signal (F1 - F6)
DL: Mbit Data Link (M1 - M12)
CRC: Cyclic Redundancy Check (C1 - C6)

ESF Frame Alignment Signal

The ESF Frame Alignment Signal (FAS) is used to locate all 24 frames and overhead bit positions. The bit values of the FAS are defined as follows:

$F1 = 0, F2 = 0, F3 = 1, F4 = 0, F5 = 1, F6 = 1.$

ESF Cyclic Redundancy Check

The Cyclic Redundancy Check field contains the CRC-6 check bits calculated over the previous Extended Superframe (CRC Message block [CMB] size = 4 632 bits). Before calculation, all 24 frame overhead bits are equal to "1". All information in the other bit positions is unchanged. The check bit sequence C1-C6 is the remainder after multiplication by x^6 and then division by the generator polynomial $x^6 + x + 1$ of the CMB. C1 is the most significant bit of the remainder. The initial remainder value is preset to all zeros.

ESF Mbit Data Link

The M-bits in the SL-ESF serve for slot timing assignment (see subclause 5.4).

5.3.1.3 Payload Structure

The SL-ESF frame payload structure provides a known container for defining the location of the ATM cells and the corresponding Reed Solomon parity values. The SL-ESF payload structure is shown in Table 9. When the INA has no data or MAC messages to send on the downstream OOB channel, it will send Idle ATM Cells as specified in [1], where the content of the Idle ATM Cell has been specified as:

0x00, 0x00, 0x00, 0x01, 0x52 (Idle ATM Cell header)

0x6A, 0x6A, ..., 0x6A (48 data bytes payload)

Table 9: ESF Payload structure

	2		53			2	
1	R1a	R1b	ATM Cell			RS parity	
2	R1c	R2a				R2 b	
3	R2c	R3a					
4	R3b	R3c				R4 a	
5	R4b	R4c					
6	R5a	R5b				R5 c	
7	R6a	R6b					
8	R6c	R7a				R7 b	
9	R7c	R8a					
10	R8b	R8c				T T	

The SL-ESF payload structure consists of 5 rows of 57 bytes each, 4 rows of 58 bytes each which includes 1 byte trailer, and 1 row of 59 bytes, which includes a 2 byte trailer. The relative ordering of data between Table 9 and Table 8, is such that reading Table 9 from left to right, and then top to bottom, corresponds to reading Table 8 from top to bottom. The most significant bit of byte R1a in Table 9, corresponds to Bit Number 1 in Table 8. The various SL-ESF payload fields are described below.

Define the downstream time-ticks T_{dn} and the upstream time-ticks T_{un} as follows:

The downstream channel is divided into 3 ms periods separated by downstream time-ticks T_{dn} and the upstream channel is divided into 3 ms periods separated by upstream time ticks T_{un} .

Then the time difference, $T_{un}-T_{dn}$, is called the *Absolute_Time_Offset*:

$$\text{Absolute_Time_Offset} = T_{un}-T_{dn}.$$

New *Absolute_Time_Offset* = current *Absolute_Time_Offset* - *Time_Offset_Value*.

(*Time_Offset_Value* is defined in subclause 5.5.4.3).

Before the NIU is going through the sign-on procedure for the first time, the current *Absolute_Time_Offset* is set according to the value passed in the Default Configuration message (taking into account the timing accuracy).

Time Offset Value is one field of the "Ranging and Power Calibration Message".

The NIU shall use the following definitions for using the R-bytes:

The boundary information contained in the downstream period that starts by downstream time-tick T_{dn} relates to the slots in the upstream period that starts at upstream time-tick T_{un+1} . This upstream period is also called the "next" one.

The reception information contained in the downstream period that starts by downstream time-tick T_{dn} relates to the slots in the upstream period that starts at upstream time-tick T_{un-2} . This upstream period is also called the "second previous" one.

ATM Cell Structure

The format for each ATM cell structure is shown in Figure 18. This structure and field coding shall be consistent with the structure and coding given in ITU-T Recommendation I.361 [7] for ATM UNI.

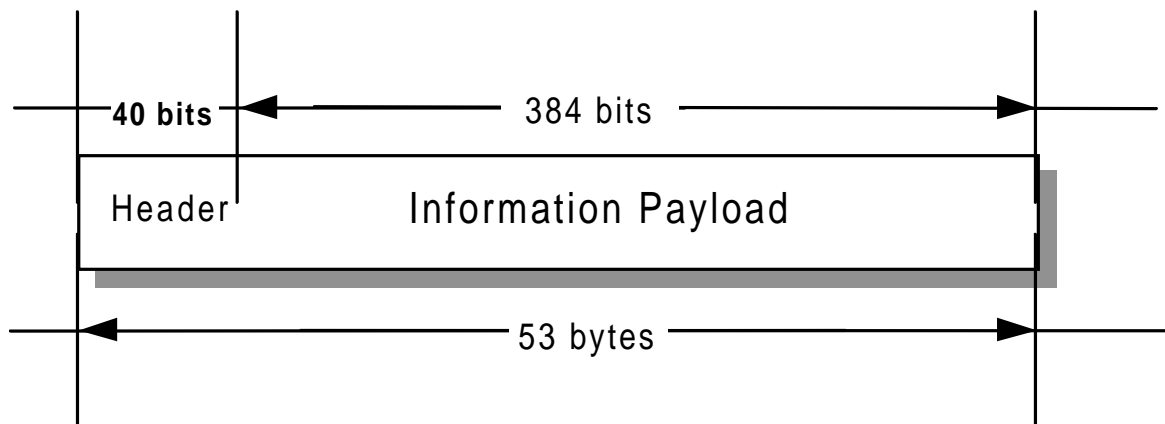

Figure 18: ATM cell format

The entire header (including the HEC byte) shall be protected by the Header Error Control (HEC) sequence. The HEC code shall be contained in the last byte of the ATM header. The HEC sequence shall be capable of:

- single-bit error correction;
- multiple-bit error detection.

Error detection in the ATM header shall be implemented as defined in [1]. The HEC byte shall be generated as described in [1], including the recommended modulo-2 addition (XOR) of the pattern 01010101b to the HEC bits. The generator polynomial coefficient set used and the HEC sequence generation procedure shall be in accordance with [1].

Channel coding and interleaving

Reed-Solomon encoding with $t = 1$ shall be performed on each ATM cell. This means that 1 erroneous byte per ATM cell can be corrected. This process adds 2 parity bytes to the ATM cell to give a codeword of (55,53).

The Reed-Solomon code shall have the following generator polynomials:

Code Generator Polynomial: $g(x) = (x + \mu^0)(x + \mu^1)$, where $\mu = 02$ hex

Field Generator Polynomial: $p(x) = x^8 + x^4 + x^3 + x^2 + 1$

The shortened Reed-Solomon Code shall be implemented by appending 200 bytes, all set to zero, before the information bytes at the input of a (255,253) encoder; after the coding procedure these bytes are discarded.

Convolutional interleaving shall be applied to the ATM cells contained in the SL-ESF. The Rxa - Rxc bytes and the two T bytes shall not be included in the interleaving process. Convolutional interleaving is applied by interleaving 5 lines of 55 bytes.

Following the scheme of Figure 19, convolutional interleaving shall be applied to the error protected packets. The convolutional interleaving process shall be based on the Forney approach, which is compatible with the Ramsey type III approach, with $I = 5$. The Interleaved frame shall be composed of overlapping error protected packets and a group of 10 packets shall be delimited by the start of the SL-ESF.

The interleaver is composed of I branches, cyclically connected to the input byte-stream by the input switch. Each branch shall be a First In First Out (FIFO) shift register, with depth $(M*j)$ cells (where $M = N/I$, $N = 55 =$ error protected frame length, $I =$ interleaving depth, $j =$ branch index). The input and output switches shall be synchronized. Each cell of the FIFO shall contain one byte.

For synchronization purposes, the first byte of each error protected packet shall be always routed into the branch "0" of the interleaver (corresponding to a null delay). The third byte of the SL-ESF payload (the byte immediately following R1b) shall be aligned to the first byte of an error protected packet.

The de-interleaver is similar, in principle, to the interleaver, but the branch indexes are reversed (i.e. branch 0 corresponds to the largest delay). The de-interleaver synchronization is achieved by routing the third data byte of the SL-ESF into the "0" branch.

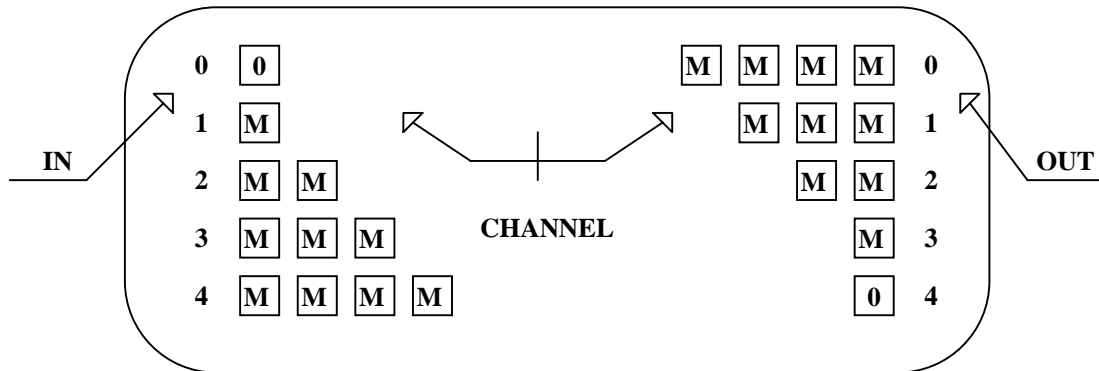

Figure 19: Interleaver and De-interleaver structures

Reception indicator fields and slot boundary fields

A downstream channel can control up to 8 upstream channels and contains control information for each of its associated upstream channels. This information is contained within structures known as MAC Flags. A set of MAC Flags is represented by either 24 bits (denoted $b0...b23$) or by 3 bytes (denoted Rxa, Rxb and Rxc):

$$Rxa = (b0...b7) = (\text{msb}...\text{lsb})$$

$$Rxb = (b8...b15) = (\text{msb}...\text{lsb})$$

$$Rxc = (b16...b23) = (\text{msb}...\text{lsb})$$

One or more consecutive MAC flags are associated to one upstream channel. This link is done in the MAC messages Default Configuration Message, Connect Message, Reprovision Message and Transmission Control Message. To the upstream channel "c" (parameter Service_Channel or Upstream_Channel_Number or New_Upstream_Channel_Number of the MAC messages mentioned above) are associated the MAC flags "x" and the following as described below. "x" corresponds to the parameter MAC_Flag_Set of the previous MAC messages. It is a 5-bit field and can take the values 1...16. Values 0 and 17...31 are invalid.

In the OOB downstream case, each HtmlResAnchor SL-ESF frame structure contains eight sets of MAC Flags represented by R_{xa} , R_{xb} and R_{xc} , where x is replaced by the numbers 1...8 providing 8 sets of MACFlags. In the case of a 3,088 Mbit/s downstream bit rate, two SL-ESFframes A and B occur during a 3 ms interval, providing 16 sets of MAC Flags. The second set of MAC Flags (contained in SL-ESF B) are denoted by R_{xa} , R_{xb} and R_{xc} , where x is replaced by the numbers 9 through 16.

In case of a 3,088 Mbit/s upstream channel, two sets of MAC Flags are required. In this case, the MAC_Flag_Set parameter represents the first of two successively assigned MAC Flag sets (R_{xa} - R_{xc} , R_{ya} - R_{yc} with $y = (x + 1)$) belongs to [1, 15] for 3,088 Mbit/s DS.

In case of a 6,176 Mbit/s upstream channel, four sets of MAC Flags are required. In this case, the MAC_Flag_Set parameter represents the first of four successively assigned MAC Flag sets (R_{xa} - R_{xc} , R_{ua} - R_{uc} , R_{va} - R_{vc} , R_{wa} - R_{wc} with $u = (x + 1)$, $v = (x + 2)$, $w = (x + 3)$, with x belongs to [1, 13] for 3,088 Mbit/s DS. In particular, if one downstream OOB 3,088 Mbit/s channel controls 6,176 Mbit/s upstream channels, at most 4 upstream channels can be controlled, due to the number of available MAC Flags.

The bits b0 to b23 are defined as follows:

b0	= ranging slot indicator for next 3 ms period (msb)
b1-b6	= slot boundary definition field for next 3 ms period
b7	= slot 1 reception indicator (as shown in Table 13)
b8	= slot 2 reception indicator (as shown in Table 13)
b9	= slot 3 reception indicator (as shown in Table 13)
b10	= slot 4 reception indicator (as shown in Table 13)
b11	= slot 5 reception indicator (as shown in Table 13)
b12	= slot 6 reception indicator (as shown in Table 13)
b13	= slot 7 reception indicator (as shown in Table 13)
b14	= slot 8 reception indicator (as shown in Table 13)
b15	= slot 9 reception indicator (as shown in Table 13)
b16-17	= reservation control for next 3 ms period
b18-b23	= CRC 6 parity (see definition in SL-ESF section)

When the upstream transmission bit rate is 3,088 Mbit/s, the 9 slots of this field and the 9 slots of the following field are valid: two consecutive Slot Configuration fields are then used. The definition of the first Slot Configuration field is unchanged. The definition of the second Slot Configuration field extends the boundary definition to cover upstream slots 10 through 18, and the reception indicators to cover upstream slots 10 through 18. When the upstream transmission bit rate is 6,176 Mbit/s, four consecutive Slot Configuration fields are then used. The definition of the first Slot Configuration field is unchanged. The definition of the second Slot Configuration field extends the boundary definition to cover upstream slots 10 through 18, and the reception indicators to cover upstream slots 10 through 18. The definition of the third Slot Configuration field extends the boundary definition to cover upstream slots 19 through 27, and the reception indicators to cover upstream slots 19 through 27. The definition of the fourth Slot Configuration field extends the boundary definition to cover upstream slots 28 through 36, and the reception indicators to cover upstream slots 28 through 36.

Ranging Slot Indicator (b0) - When this bit is active ($b0 = 1$), the first three slots of upstream channel " x " which correspond to the occurrence of the next superframe of the related downstream channel are designated as ranging slots. A ranging message may be transmitted in the second ranging slot according to the algorithm defined for ranging, and the first and third ranging slots may not be used for transmission (guard band for ranging operations).

Slot Boundary Definition field (b1-b6) - Slot types are assigned to upstream slots using bits b0-b6. The slots are grouped into regions among "spans" of 2*9 slots (two spans of 9 slots are used for 3,088 Mbit/s), or 4*9 slots (four spans of 9 slots are used for 6,176 Mbit/s), such that slots of a similar type are contained within the same region. The order of the regions is Ranging slot, Contention based slots, Reserved slots and Fixed rate based slots. If a ranging slot is available within a "span", it will consist of the first three slot times in the "span", assuming b1-b6 are not in the range 55-63 (see Table 12). A ranging slot is indicated by b0 = 1. The boundaries between the remaining regions of the "spans" are defined by b1-b6. The boundaries are defined as shown in Table 10.

Table 10: Slot Boundary Definition field (b1-b6)

Boundary 0	slot 1
Boundary 1	slot 2
Boundary 2	slot 3
Boundary 3	slot 4
Boundary 4	slot 5
Boundary 5	slot 6
Boundary 6	slot 7
Boundary 7	slot 8
Boundary 8	slot 9
Boundary 9	

The boundary positions are defined by b1-b6 as shown in Table 11.

Table 11: Boundary positions (b1-b6)

(note 1) (note 2)	0	1	2	3	4	5	6	7	8	9
0 (note 3)	0	1	2	3	4	5	6	7	8	9
1 (note 3)		10	11	12	13	14	15	16	17	18
2 (note 3)			19	20	21	22	23	24	25	26
3				27	28	29	30	31	32	33
4					34	35	36	37	38	39
5						40	41	42	43	44
6							45	46	47	48
7								49	50	51
8									52	53
9										54

NOTE 1: row = Contention based / Reserved region boundary.
 NOTE 2: column = Reserved packet /Fixed rate based region boundary.
 NOTE 3: When the ranging control slot indicator (b0) is set to "1", the values in rows 0 to 2 are illegal values, and values in row 3 means that there are no contention slots, because slots 1-3 are defined as ranging control slots.

Example: b0 = 0, b1-b6 = 22: Contention (1-2), reserved (3-5), Fixed rate (6-9)

The remaining values of the Slot Boundary Definition Field are provided in Table 12.

Table 12: Slot Boundary Definition Field

b1-b6 value	ranging control slots	contention slots	reservation slots	fixed rate slots
55	1-6	7-9	-	-
56	1-6	7-8	-	9
57	1-6	7	8-9	-
58	1-6	7	8	9
59	1-6	7	-	8-9
60	1-6	-	7-8	9
61	1-6	-	7	8-9
62	1-6	-	-	7-9
63	1-9	-	-	-

NOTE 1: For b1-b6 = 55 - 63, b0 shall be set to 1. Note that for b1-b6 between 55 and 62, two ranging slots are provided (2 and 5). For b1-b6 = 63, three ranging slots are provided (2, 5, and 8).

The values in the above tables are derived from b1-b6 in the following manner:

$$b1 + (b2 \times 2) + (b3 \times 4) + (b4 \times 8) + (b5 \times 16) + (b6 \times 32)$$

Warning: This formula indicates that b6 is considered as msb of b1-b6 word, whereas b0 is msb of the entire word b0-b23. Although this "looks" inconsistent, it has not been changed for the purpose of compatibility with the DAVIC standard.

NOTE 2: If slot boundary fields change while some NIUs have already been allocated slots in the reservation slots area, these NIUs are responsible of updating the list of physical slots. Specifically, slots are assigned by MAC Reservation Grant messages, which contain a Reference slot that does not depend on the slot boundary fields and a Grant_slot_count which corresponds to the number of slots assigned within the reservation slots boundary field. If the field changes, the list of physical slots on which the NIU can transmit automatically changes accordingly.

Slot Reception Indicators (b7 - b15) - When a slot reception indicator is active ("1"), this indicates that a cell was received without collision. The relationship between a given US slot and its indicator is shown in Table 13. When the indicator is inactive ("0"), this indicates that either a collision was detected or no cell was received in the corresponding upstream slot.

Slot reception indicators lead to the retransmission procedure only when contention access is used as described in subclause 5.5.2.4.

Table 13: Relationship of US slot to DS Indicator at the INA

	1,544 Mbit/s Downstream	3,088 Mbit/s Downstream
256 kbit/s Upstream	NONAPPLICABLE	NON APPLICABLE
1,544 Mbit/s Upstream	NON APPLICABLE	NON APPLICABLE
3,088 Mbit/s Upstream	NON APPLICABLE	
6,176 Mbit/s Upstream	NON APPLICABLE	
<p>NOTE 1: "I" indicates the downstream frame(s) in which Indicators (contained within the MAC Flag Sets) are sent. These indicators control the upstream slots in the shaded area.</p> <p>NOTE 2: In the 3,088 downstream, two successive frames contain HtmlResAnchor MAC Flag Sets 1...16.</p> <p>NOTE 3: Two successive MAC Flag Sets are used to control the 18 slots of a 3,088 upstream channel.</p> <p>NOTE 4: Four successive MAC Flag Sets are used to control the 36 slots of a 6,176 upstream channel. In this case you can control max. 4 upstreams using the 3,088 downstream.</p> <p>NOTE 5: Note that this table refers to the position of US slots with respect to the positions of DS superframes at the INA receiver. NIUs should have their Time_Offset_Value of transmission set such that this table applies.</p>		

Reservation Control (b16-b17) - When the reservation control field has the value of 0, no reservation attempts are allowed to be transmitted on the corresponding QPSK upstream channel during the slot positions associated with the next 3 ms period. When the reservation control field has the value of 1, reservation attempts can be made. The values 2 and 3 are reserved. A reservation attempt corresponds to sending a MAC Reservation Request message (see MAC section). b16 is msb.

CRC 6 Parity (b18-b23) - This field contain a CRC 6 parity value calculated over the previous 18 bits. The CRC 6 parity value is described in the SL-ESF frame format subclause 5.3.1.2, b18 is msb.

In the case where there is more than one OOB DS QPSK channel related to an upstream QPSK channel, the SL-ESF overhead bits and the payload R-bytes shall be identical in those OOB DS channels, with the exception of the overhead CRC (C1-C6) bits, which are specific to each of those OOB DS channels. Such related DS channels shall be synchronized (transmitted synchronously). This scenario applies for example when a lot more bandwidth is needed for DS information than US information. An NIU is but not required to have more than one QPSK tuner.

The MAC messages that are required to perform the MAC functions for the upstream channel shall be transmitted on each of its related OOB DS channels.

Trailer bytes

These bytes are not used. They are equal to 0.

5.3.2 Forward Interaction Path (Downstream IB)

5.3.2.1 IB Signalling MPEG2-TS Format (MAC Control Message)

The structure that is utilized when the downstream QPSK IB channel is carrying MPEG2-TS packets is shown in Figure 20 MSBs of each field are transmitted first.

4	3	2	3	26	26	40	40	40	4
MPEG Header	Upstream Marker	Slot Numbr	MAC Flag Control	MAC Flags	Ext. Flags	MAC msg.	MAC msg.	MAC msg.	rsrvc

Figure 20: Frame structure (MPEG-2 TS format)

where:

MPEG Header is the 4 byte MPEG-2 Transport Stream Header as defined in ISO 13818-1 [9] with a specific PID designated for MAC messages. This PID is 0x1C. The transport_scrambling_control field of the MPEG header shall be set to "00".

Upstream Marker is a 24-bit field which provides upstream QPSK synchronization information. (As mentioned in subclause 5.1.4, at least one packet with synchronization information shall be sent in every period of 3 ms). The definition of the field is as follows:

bit 0: upstream marker enable (msb)

When this field has the value "1", the slot marker pointer is valid. When this field has the value "0", the slot marker pointer is not valid.

bit 1-3: MAC Message Framing

Bit 1 relates to the first MAC message slot within the MPEG frame, bit 2 to the second, and bit 3 to the last slot. The meaning of each bit is:

- 0: a MAC message terminates in this slot.
- 1: a MAC message continues from this slot into the next, or the slot is unused, in which case the first two bytes of the slot are 0x0000.

bit 4-7: reserved

bit 8-23: upstream slot marker pointer

The slot marker pointer is a 16-bit unsigned integer which indicates half the number of downstream "symbol" clocks between the next Sync byte and the next 3 ms time marker. Bit 23 is to be considered as the most significant bit of this field.

Slot Number is a 16-bit field which is defined as follows: (As mentioned in subclause 5.1.4, at least one packet with synchronization information shall be sent in every period of 3 ms).

bit 0: slot position register enable (msb)

When this field has the value "1", the slot position register is valid. When this field has the value "0", the slot position register is not valid.

bit 1-3: reserved

bit 4 is set to the value "1". This bit is equivalent to M12 in the case of OOB downstream.

bit 5: odd parity

This bit provides odd parity for upstream slot position register. This bit is equivalent to M11 in the case of OOB downstream.

bits 6-15: upstream slot position register

The upstream slot position register is a 10-bit counter which counts from 0 to n with bit 6 the msb. These bits are equivalent to M10-M1 in the case of OOB downstream.

(see subclause 5.4 or more information on the functionality of the upstream slot position register)

MAC Flag Control is a 24-bit field (b0 (msb),b1, b2...b23) which provides control information which is used in conjunction with the "MAC Flags" and "Extension Flags" fields. The definition of the MAC Flag Control field is as follows:

b0-b2	Channel 0 control field
b3-b5	Channel 1 control field
b6-b8	Channel 2 control field
b9-b11	Channel 3 control field
b12-b14	Channel 4 control field
b15-b17	Channel 5 control field
b18-b20	Channel 6 control field
b21-b23	Channel 7 control field

Each of the above Channel "c" Control Fields is defined as follows:

Channel "c" control field (a, b, c) = (bn, bn + 1, bn + 2) where n = 3*c

bit a: 0 - MAC Flag Set of channel "c" disabled

1 - MAC Flag Set of channel "c" enabled

"MAC Flag Set of Channel "c" enabled" means that the Mac Flags assigned to the upstream channel "c" are valid in this TS packet. The relation between the channel number "c" and the assigned Mac Flag sets is provided in the "Default Configuration", "Connect", "Reprovision" and "Transmission control" messages.

In case of a 3,088 Mbit/s upstream channel, two sets of HtmlResAnchor MAC Flags are required. In this case, the MAC_Flag_Set parameter represents the first of two successively assigned HtmlResAnchor MAC Flag sets. The definition of the second slot configuration field extends the boundary definition to slots 10 through 18, and the reception indicators cover slots 10 through 18.

In case of a 6,176 Mbit/s upstream channel, four sets of MAC Flags are required. In this case, the MAC_Flag_Set parameter represents the first of four successively assigned MAC Flag sets. The definition of the second slot configuration field extends the boundary definition to slots 10 through 18, and the reception indicators cover slots 10 through 18. The definition of the third Slot Configuration field extends the boundary definition to cover upstream slots 19 through 27, and the reception indicators to cover upstream slots 19 through 27. The definition of the fourth Slot Configuration field extends the boundary definition to cover upstream slots 28 through 36, and the reception indicators to cover upstream slots 28 through 36.

bit b, c: 00 - all flags valid for second previous 3 ms period (out-of-band signalling equivalent)

01 - flags valid for 1st ms of previous 3 ms period

10 - flags valid for 2nd ms of previous 3 ms period

11 - flags valid for 3rd ms of previous 3 ms period

MAC Flags is a 26 byte field containing 8 slot configuration fields (24 bits each) which contain slot configuration information for the related upstream channels followed by two reserved bytes (The First 3 bytes correspond to MAC Flag Set 1, second 3 bytes to MAC Flag Set 2, etc). The definition of each slot configuration field is defined as follows:

b0	ranging control slot indicator for next 3 ms period (msb)
b1-b6	slot boundary definition field for next 3 ms period
b7	slot 1 reception indicator for [second] previous 3 ms period
b8	slot 2 reception indicator for [second] previous 3 ms period
b9	slot 3 reception indicator for [second] previous 3 ms period
b10	slot 4 reception indicator for [second] previous 3 ms period
b11	slot 5 reception indicator for [second] previous 3 ms period
b12	slot 6 reception indicator for [second] previous 3 ms period
b13	slot 7 reception indicator for [second] previous 3 ms period
b14	slot 8 reception indicator for [second] previous 3 ms period
b15	slot 9 reception indicator for [second] previous 3 ms period
b16-17	reservation control for next 3 ms period
b18-b23	CRC 6 parity

The slot configuration fields are used in conjunction with the MAC Flag Control field defined above. Note that when the MAC Flag Control field designates that a 1 ms flag update is enabled; (1) the reception indicators refer to the previous 3 ms period (the bracketed term [second] is omitted from the definition), (2) only the reception indicators which relate to slots which occur during the designated 1 ms period are valid, and (3) the ranging control slot indicator, slot boundary definition field, and reservation control field are valid and consistent during each 3 ms period.

Extension Flags is a 26 byte field which is used when one or more 3,088 Mbit/s or 6,176 Mbit/s upstream QPSK links are used. The definition of the Extension Flags field is identical to the definition of the MAC Flags field above. The "Extension Flags" field contains the MAC Flags from 9 to 16.

The **MAC Message** field contains a 40 byte message, the general format is defined in subclause 5.5.2.7.

reserved field c is a 4 byte field reserved for future use.

5.3.2.2 Frequency of IB Signalling Information

IB Downstream Time-Tick Definition

In the case of IB, downstream time-tick T_{dn} is the 3 ms time marker Downstream (defined in subclause 5.4.2).

Upstream Marker and Slot Position Register Number

The MAC Control Message structures shall be transmitted one time every 3 ms with an enabled slot position register (slot_position_register_enable = 1) and a valid upstream marker (upstream_Marker_enable = 1) (i.e. both are valid in the same packet).

MAC Flag Control, MAC Flags & Extension Flags

The MAC Control Message structures containing MAC Flag Control, MAC Flags & Extension Flags shall be transmitted so as to the NIU has at least 1 millisecond to process the MAC Flag Information. This information shall be received by the NIU between two downstream time-ticks (see subclause 5.3.1.3).

MAC Messages

Additional MAC Control Message structures containing only MAC messages, i.e. with a disabled slot position register (`slot_position_register_enable = 0`), a disabled upstream marker (`upstream_marker_enable = 0`) may be transmitted at any time.

5.3.3 Return Interaction Path (Upstream)

5.3.3.1 Slot Format

The format of the upstream slot is shown in Figure 21 below. A Unique Word (UW) (4 bytes) provides a burst mode acquisition method. The payload area (53 bytes) contains a single message cell. The RS Parity field (6 bytes) provides $t = 3$ Reed Solomon protection RS (59,53) over the payload area. The Guard band (1 byte) provides spacing between adjacent packets.

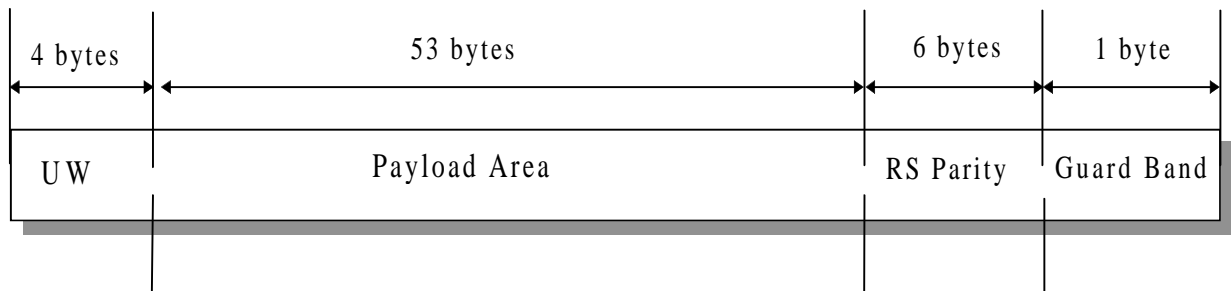

Figure 21: Slot format

The structure and field coding of the message cell shall be consistent with the structure and coding given in ITU-T Recommendation I.361 [7] for ATM UNI.

Unique Word

The unique word is four bytes long: 0X 00 FC FC F3 hex. The unique word for minislots is four bytes: 0X 00 FC FC F3 hex, transmitted in this order.

ATM Cell Structure

The format for each ATM cell structure is illustrated below. This structure and field coding shall be consistent with the structure and coding given in ITU-T Recommendation I.361 [7] for ATM UNI.

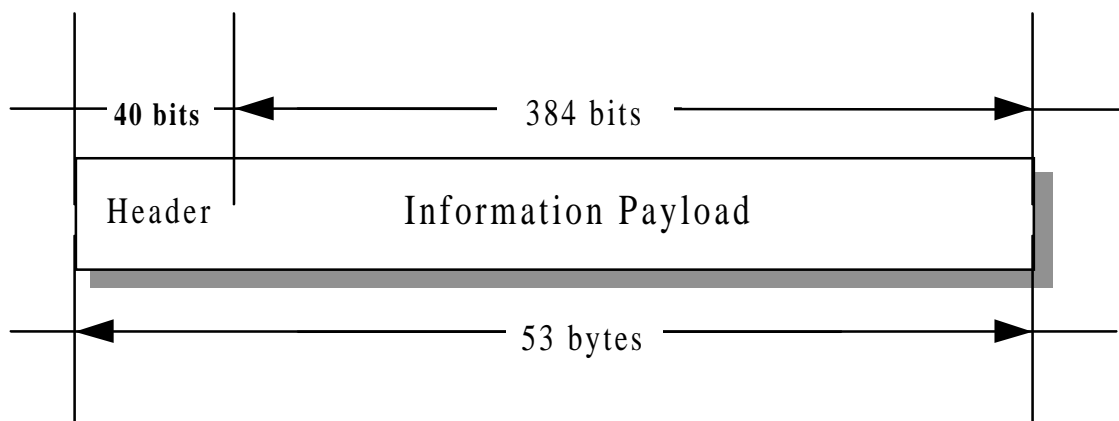

Figure 22: ATM cell format

The entire header (including the HEC byte) shall be protected by the Header Error Control (HEC) sequence. The HEC code shall be contained in the last byte of the ATM header. The HEC sequence shall be capable of:

- single-bit error correction;
- multiple-bit error detection.

Error detection in the ATM header shall be implemented as defined in [1]. The HEC byte shall be generated as described in [1], including the recommended modulo-2 addition (XOR) of the pattern 01010101b to the HEC bits. The generator polynomial coefficient set used and the HEC sequence generation procedure shall be in accordance with [1].

Channel Coding

Reed-Solomon encoding shall be performed on each ATM cell with $T = 3$. This means that 3 erroneous byte per ATM cell can be corrected. This process adds 6 parity bytes to the ATM cell to give a codeword of (59,53). The shortened Reed-Solomon Code shall be implemented by appending 196 bytes, all set to zero, before the information bytes at the input of a (255,249) encoder; after the coding procedure these bytes are discarded.

The Reed-Solomon code shall have the following generator polynomials:

Code Generator Polynomial: $g(x) = (x + \mu^0)(x + \mu^1)(x + \mu^2) \dots (x + \mu^5)$,

where $\mu = 02$ hex.

Field Generator Polynomial: $p(x) = x^8 + x^4 + x^3 + x^2 + 1$.

Guard Band

The guard band is 1 byte long (4 QPSK symbols). It provides some extra protection against synchronization errors.

For the minislot slot format see subclause 5.6.2.

5.3.4 Minimum Processing Time

The NIU has to be able to process the boundary information in the Mac flag sets within 1 millisecond.

5.4 Slot Timing Assignment

5.4.1 Downstream Slot Position Reference (Downstream OOB)

Upstream synchronization is derived from the downstream extended superframe (OOB) by noting the slot positions as shown in Table 14.

Table 14: Downstream slot position reference

Frame Number	Bit Number	Overhead Bit	Slot position reference
1	0	M1	◆ Slot Position ¹
2	193	C1	
3	386	M2	
4	579	F1 = 0	
5	772	M3	
6	965	C2	
7	1 158	M4	
8	1 351	F2 = 0	
9	1 544	M5	◆ Slot Position
10	1 737	C3	
11	1 930	M6	
12	2 123	F3 = 1	
13	2 316	M7	
14	2 509	C4	
15	2 702	M8	
16	2 895	F4 = 0	
17	3 088	M9	◆ Slot Position
18	3 281	C5	
19	3 474	M10	
20	3 667	F5 = 1	
21	3 860	M11	
22	4 053	C6	
23	4 246	M12	
24	4 439	F6 = 1	

For the 3,088 Mbit/s rate downstream, the 3 ms time marker only appears once every two superframes. The M12 bit (see subclause 5.4) is used to differentiate between the two superframes.

5.4.2 Downstream Slot Position Reference (Downstream IB)

Upstream synchronization is derived from the Transport Stream by noting the 3 ms time marker Downstream as shown in Figure 23. From the bits of the upstream marker field contained in the MPEG-2 TS packet, the 3 ms time marker is obtained by counting a number of symbol clocks equal to (b23-b8). This marker is equivalent to the first slot position of the superframe for the OOB case.

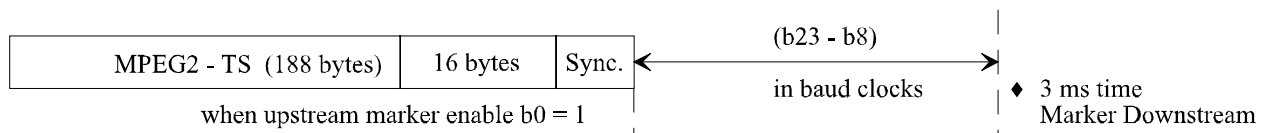

Figure 23: Position of the 3 ms time marker for IB signalling

NOTE: The upstream marker pointer gives half the number of baud clocks to count; the baud rate considered is before inner coding and transmission.

In order to describe how the US slot position is derived from the location of the DS 3 ms time marker at the NIU, consider the following system diagram.

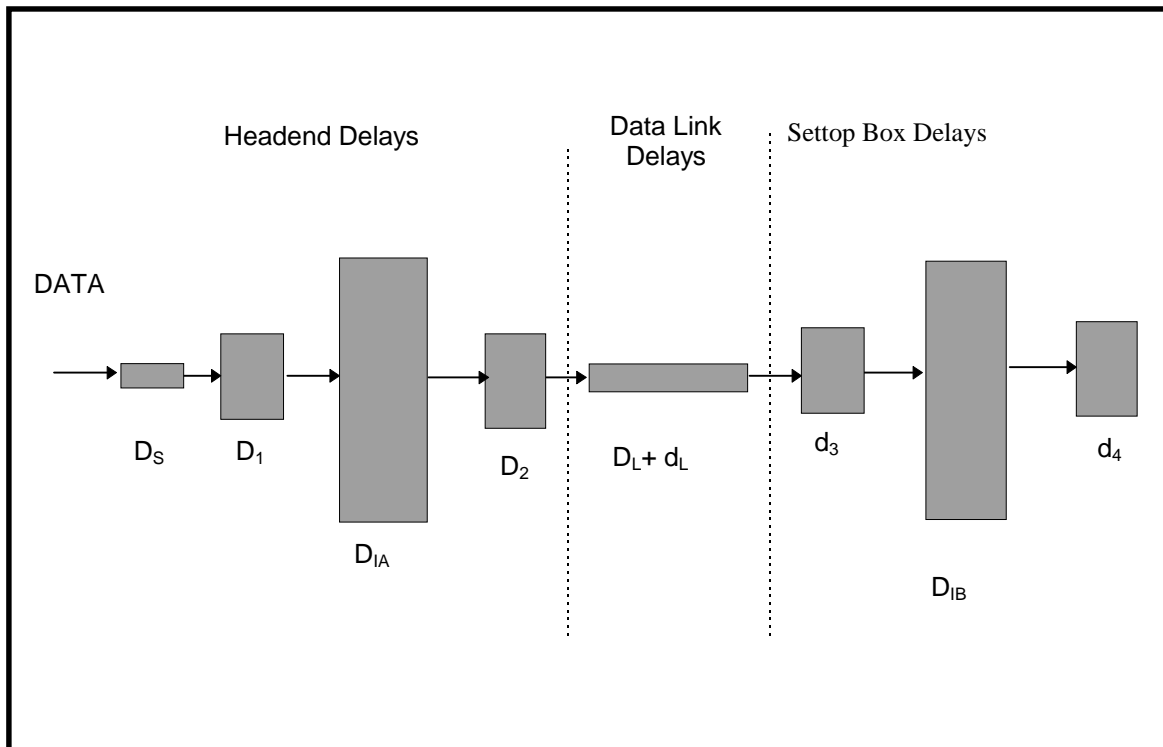

Figure 24: System Model for Timing Analysis

The delay between the location of the end of the Upstream Marker and the beginning of the next Sync byte, designated as D_S , is a constant value for each bit rate equal to the equivalent time of 197 bytes, or

$$(197 * 8 / x) \text{ symbol clocks}$$

where:

$$x = 2, \text{ for QPSK}$$

There will be some processing delay in the Head-end hardware between the location where the Upstream Marker is inserted in the MAC packet and the arrival of the data into the interleaver. This should be a constant delay, D_1 , which is the same for every incoming byte, including the sync byte following the Upstream Marker.

The delay due to the interleaving process in the Head-end is D_{IA} and will be zero for each sync byte.

There will be some processing delay in the Head-end hardware between the output of the interleaver and the output of the QPSK IB modulator. This should be a constant delay, D_2 , for every byte in the outgoing stream.

The data link is composed of two delay values, D_L , the constant link delay that every STU experiences, and d_L , the variable link delay for each STU which is due to the fact that each STU is located at a different distance from the Head-end. This variable link delay is compensated for by the ranging operation.

There will be some processing delay in the STU hardware between the input of the QPSK IB demodulator and the input of the de-interleaver. This delay is design dependent, d_3 , and may be a constant delay or a variable delay for each byte in the data stream.

The delay due to the de-interleaving process in the STU is D_{IB} , and will be equal to the entire interleave delay for each sync byte.

The total interleave delay,

$$D_I = D_{IA} + D_{IB}$$

will be constant for each byte. The value will be given by:

$$D_I = 204 * 8 * (\text{interleave_depth} - 1) / \text{bit rate.}$$

There will be some processing delay in the STU hardware between the output of the de-interleaver and the circuitry that utilizes the Upstream marker and following sync byte for generating the local 3 ms time marker. This delay, which includes FEC, is design dependent, d_4 , and may be a constant delay or a variable delay for each byte in the data stream.

The accumulated delay in the data link is composed of a number of constant terms and three variable terms. The constant terms will be identical for every STU that is utilizing a particular QPSK IB channel for in-band timing and thus becomes a fixed offset between when the counter which is loading the Upstream Marker value and the actual location of the 3 ms time marker at each STU. Each STU is responsible for compensating for the design dependent delays, d_3 and d_4 , before utilizing the Upstream Marker value for generating the 3 ms time marker. The variable link delay, d_L , will be compensated for via the ranging algorithm, in the same way as performed when out-of-band signalling is employed.

5.4.3 Upstream Slot Positions

Transmission on each QPSK upstream channel is based on dividing access by multiple NIU units by utilizing a negotiated bandwidth allocation slot access method. A slotting methodology allows the transmit slot locations to be synchronized to a common slot position reference, which is provided via the related downstream MAC control channel. Synchronizing the slot locations increases message throughput of the upstream channels since the ATM cells do not overlap during transmission.

The slot position reference for upstream slot locations is received via the related downstream MAC control channel by each NIU. Since each NIU receives the downstream slot position reference at a slightly different time, due to propagation delay in the transmission network, slot position ranging is required to align the actual slot locations for each related upstream channel. The upstream slot rates are 12 000 upstream slots/sec when the upstream transmission rate is 6,176 Mbit/s, 6 000 upstream slots/sec when the upstream transmission bit rate is 3,088 Mbit/s.

The number of slots available in any one second is given by:

$$\text{number of slots/sec} = \text{upstream transmission bit rate} / 512 - (\text{extra guardband})$$

where extra guardband may be designated between groups of slots for alignment purposes.

The M-bits in the SL-ESF serve two purposes:

- to mark the slot positions for the upstream Contention and Reservation and Fixed Rate based signalling links (see subclause 5.4);
- to provide slot count information for upstream message bandwidth allocation management in the NIU.

M-bits M1, M5, and M9 mark the start of an upstream slot position for upstream message transmission.

5.4.3.1 Rate 256 kbit/s

Non applicable.

5.4.3.2 Void

5.4.3.3 Rate 1,544 Mbit/s

Non applicable.

5.4.3.4 Rate 3,088 Mbit/s

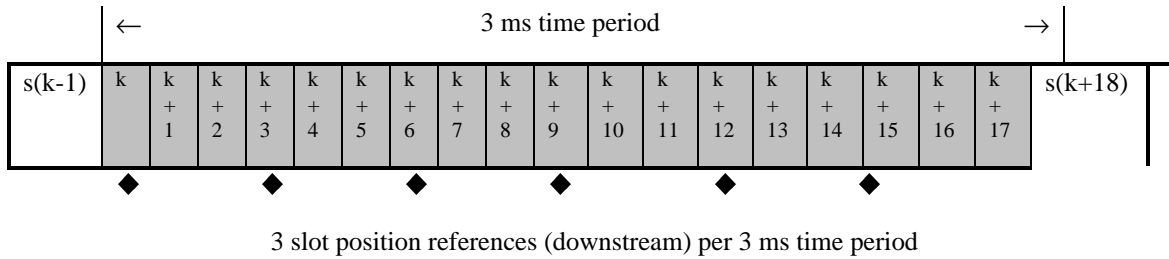

In the case where the downstream OOB rate is 3,088 Mbit/s, there are 6 slot position references downstream during the transmission of 18 upstream packets. In the case of IB downstream, packet « k » is sent when the 3 ms time marker is received.

The relationship between the received slot position reference and the actual slot transmit position is given by:

$$\text{slot_transmit_position} = \text{slot_position_reference}(\text{valid}) + \text{slot_position_offset},$$

where only the slot_position_references which cause the upstream_slot_position_counter to be loaded are valid (see subclause 5.4.4), and the slot_position_offset is derived from the Time_Offset_Value provided via the Range_and_Power_Calibration_Message.

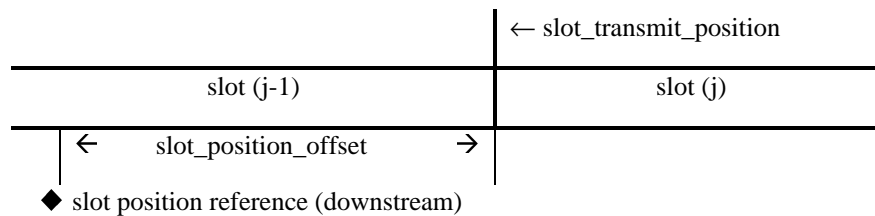

In the case where the upstream transmission bit rate is 3,088 Mbit/s, the actual slot transmission locations are given by:

$$\text{slot_transmission_location} (m) = \text{slot_transmit_position} + (m * 512),$$

where m = 0,1,2,3,4,5; is the position of the slot with respect to the slot_transmit_position. This leaves a free time interval (FI = 16 bits)) before the next slot_transmit_position occurs, during which no NIU transmits anything.

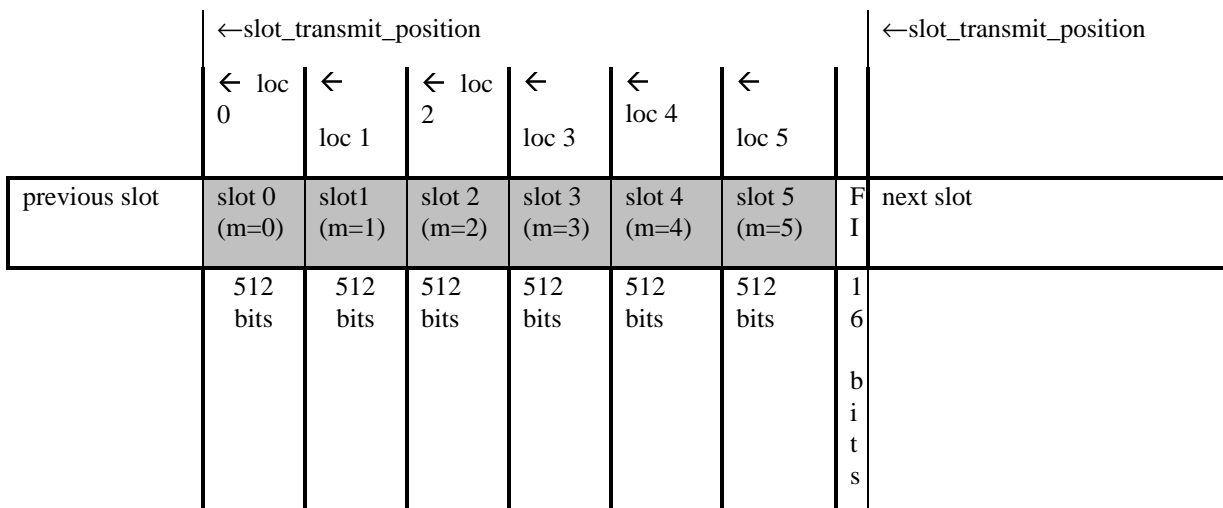

5.4.3.5 Rate 6,176 Mbit/s

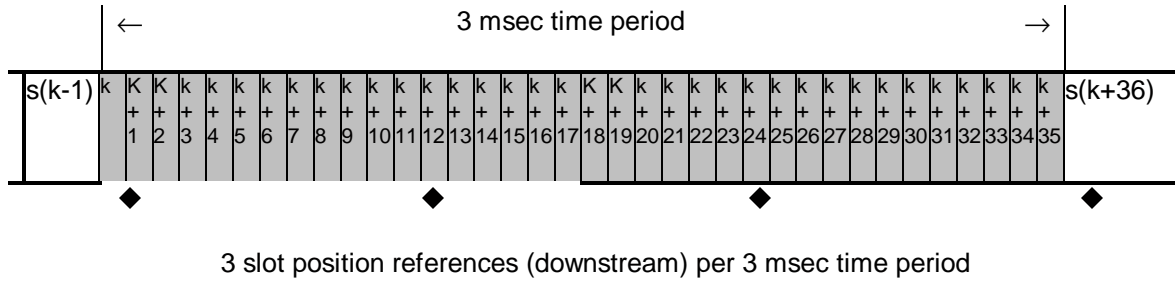

There are 6 slot position references downstream during the transmission of 36 upstream packets. In the case of IB downstream, packet « k » is sent when the 3 ms time marker is received.

The relationship between the received slot position reference and the actual slot transmit position is given by:

$$\text{slot_transmit_position} = \text{slot_position_reference}(\text{valid}) + \text{slot_position_offset},$$

where only the slot_position_references which cause the upstream_slot_position_counter to be loaded are valid (see subclause 5.4.4), and the slot_position_offset is derived from the Time_Offset_Value provided via the Range_and_Power_Calibration_Message.

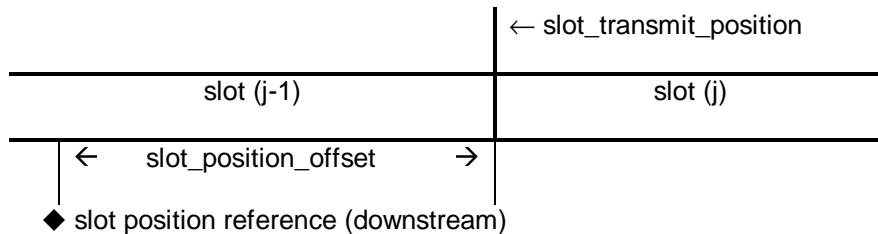

In the case where the upstream transmission bit rate is 6,176 Mbit/s, the actual slot transmission locations are given by:

$$\text{slot_transmission_location} (m) = \text{slot_transmit_position} + (m * 512),$$

where $m = 0,1,2,3,4,5,6,7,8,9,10,11$; is the position of the slot with respect to the slot_transmit_position. This leaves a free time interval (FI = 32 bits)) before the next slot_transmit_position occurs, during which no NIU transmits anything.

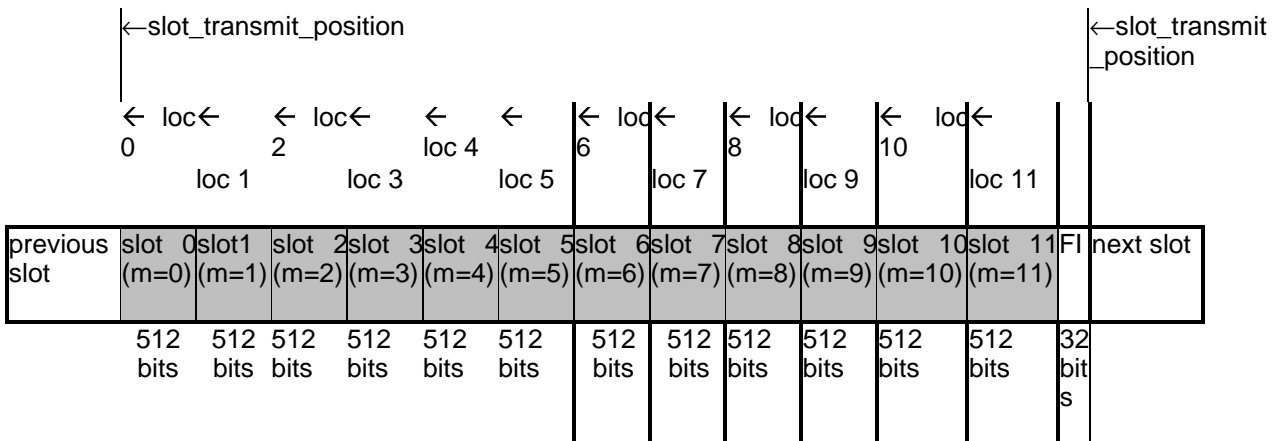

5.4.4 Slot Position Counter

The M-bits M10 - M1 are a register, called the upstream slot position register, which counts from 0 to N, incrementing by one every 3 ms, where N is an unsigned integer which indicates slot position cycle size (the value of N is calculated from Service_Channel_Last_Slot sent in the Default Configuration Message and the upstream transmission bit rate of the service channel. For the case of 3,088 Mbit/s the maximum value is imposed to be 8 189, and for the case of 6,176 Mbit/s the maximum value is imposed to be 8 171. The value of N shall be the same for all DS carriers, and N is related to the number of US slots by:

$$\text{Number_of_US_Slots} = 3 * m * (N+1), \text{ where } m \text{ is related to US rate as described below.}$$

The upstream slot position register indicates the upstream slot positions that will correspond to the next SL-ESF frame. There are 12 upstream slots per ms when the upstream transmission bit rate is 6,176 Mbit/s, 6 upstream slots per ms when the upstream transmission bit rate is 3,088 Mbit/s. The corresponding upstream slot rates are, therefore, 12 000 upstream slots/sec when the upstream transmission bit rate is 6,176 Mbit/s, 6 000 upstream slots/sec when the upstream transmission bit rate is 3,088 Mbit/s.

There are 36 upstream minislots per ms when the upstream data rate is 6,176 Mbit/s, there are 18 upstream minislots per ms when the upstream data rate is 3,088 Mbit/s. The corresponding upstream minislot rates are, therefore, 36 000 upstream minislots/sec when the upstream data rate is 6,176 Mbit/s, 18 000 upstream minislots/sec when the upstream data rate is 3,088 Mbit/s. The algorithm to determine the upstream slot position counter value is given below:

In the case of OOB downstream, the algorithm to determine the upstream slot position counter value is given below:

upstream_slot_position_register = value of M-bits latched at bit_position M11 (M10 - M1)

if (upstream_rate == 3,088 Mbit/s) { m = 6; }

 else if (upstream_rate == 6,176 Mbit/s) { m = 12; }

if (bit_position == M1 and previous M12 == 1)

 {upstream_slot_position_counter = upstream_slot_position_register * 3 * m; }

if (bit_position == M5)

 if (previous M12 == 0)

 {upstream_slot_position_counter = upstream_slot_position_counter + m; }

if (bit_position == M9)

 if (and previous M12 == 1))

 {upstream_slot_position_counter = upstream_slot_position_counter + m; }

if (bit_position == M11)

 {temp_upstream_slot_position_register = (M10, M9, M8, ..., M1); }

if ((bit_position == M12 and M12 == 1))

 {upstream_slot_position_register = temp_upstream_slot_position_register; }

where the M-bits will be defined as follows:

M1 - M10 = 10-bit ESF counter which counts from 0 to n with M10 the most significant bit (MSB);

M11 = odd parity for the ESF counter, i.e., M11 = 1 if the ESF Counter (M1-M10) has an even number of bits set to 1;

M12 = 1: ESF counter valid
0: ESF counter not valid

The values assigned to M12 are as follows:

- 1) The information is always transmitted in pairs of superframe, where superframe-A is the first superframe in the pair, and superframe-B is the second superframe in the pair. In this case, the M12 bit of superframe-A is set to the value "0" and the M12 bit of superframe-B is set to the value "1".
- 2) When the downstream channel is IB, $M12 = 1$.

In the case of IB downstream, the upstream slot timing should mimic that of the OOB downstream.

5.5 MAC Functionality

5.5.1 MAC Reference Model

The scope of this subclause is limited to the definition and specification of the MAC Layer protocol. The detailed operations within the MAC layer are hidden from the above layers.

This subclause focuses on the required message flows between the INA and the NIU for Media Access Control. These areas are divided into three categories: Initialization, Provisioning and Sign On Management, Connection Management and Link Management.

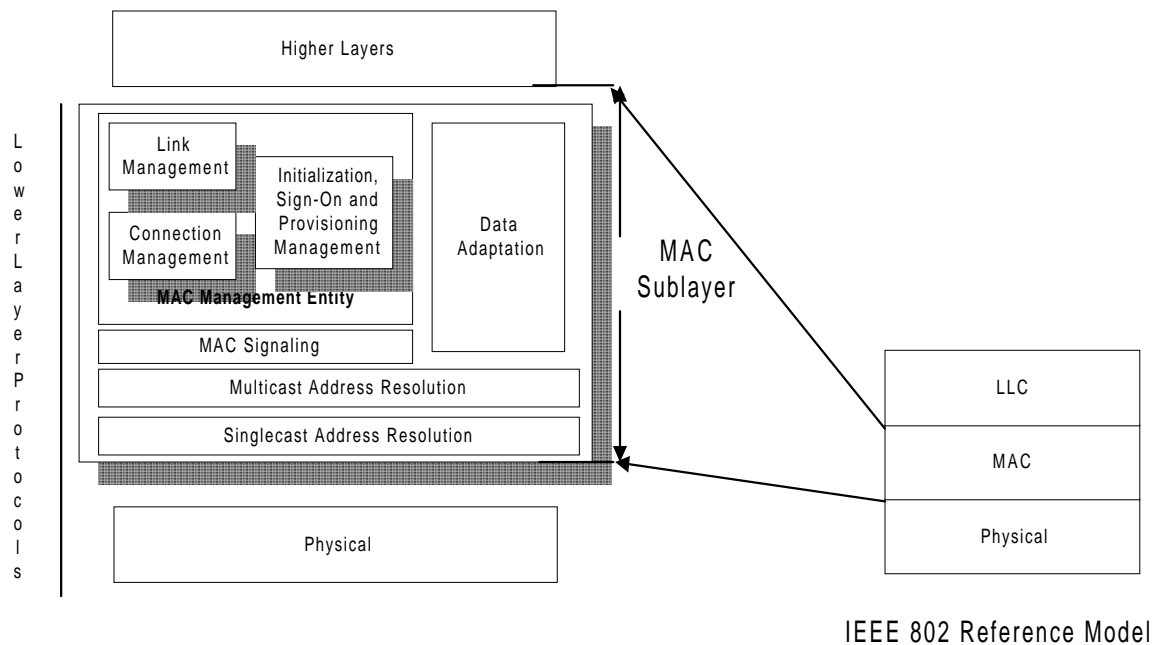

Figure 25: MAC Reference Model

5.5.2 MAC Concept

5.5.2.1 Relationship Between Higher Layers and MAC Protocol

The goal of the MAC protocol is to provide tools for higher layer protocols in order to transmit and receive data transparently and independently of the physical layer. Higher layer services are provided by the INA to the STU. The INA is thus responsible of indicating the transmission mode and rate to the MAC layer for each type of service.

Specifically, for each connection provided by higher layers on the INA side (VPI/VCI), a connection ID is associated at the MAC layer. The maximum number of simultaneous connections that a NIU should support is defined as follows:

Level A: Only one connection at a time can be handled by a NIU.

Level B: As many connections as needed, defined dynamically by the INA, following higher layers requests. Note that in this case all connections should be assigned to the same frequency upstream and downstream for implementation reasons.

Note however, that bandwidth (time slots) does not need to be assigned immediately by the INA for a given connection. This means that a connection ID may exist at the NIU side without associated slot numbers.

The INA is responsible of providing transmission bandwidth to the NIUs when needed by higher layers. However, since the NIU shall transmit all data from the STU, the NIU is also responsible for requesting for more bandwidth if not already provided by the INA.

An initial connection is allocated to the STB by the INA, following the successful completion of sign-on at power up. This connection can be used to send data from higher layers leading to further interactive connections. Note that this connection can be associated to a zero transmission rate (no initial bandwidth allocation).

5.5.2.2 Relationship Between Physical Layer and MAC Protocol

Up to 8 QPSK Upstream channels can be related to each downstream channel which is designated as a MAC control channel. These upstream channels can be used in different, physically separated coaxial cells where space division multiplexing (SDM) is applied or within a single cell where frequency division multiplexing (FDM) is applied. Mixed scenarios where space and frequency division multiplexing is applied in either upstream or downstream direction are also possible. Network scenarios showing when to apply SDM or FDM can be found in [guideline document]. An example of a frequency allocation for the FDM scenario is shown in Figure 26. This relationship consists of the following items:

- 1) Each of these related upstream channels share a common slot position. This reference is based on 1 millisecond time markers in case of OOB and 3 milliseconds time markers in case of IB that are derived via information transmitted via the downstream MAC control channel.
- 2) Each of these related upstream channels derive slot numbers from information provided in the downstream MAC control channel.
- 3) The Messaging needed to perform MAC functions for each of these related upstream channels is transmitted via the downstream MAC control channel.

The Media Access Control Protocol supports multiple downstream Channels. In instances where multiple Channels are used, the INA shall specify a single OOB frequency called the Provisioning Channel, where NIU's perform Initialization and Provisioning Functions. Also, in networks where IB NIUs exist, provisioning should be included in at least one IB channel. An aperiodic message is sent on each downstream control channel which points to the downstream Provisioning Channel. In instances where only a single frequency is in use, the INA shall utilize that frequency for Initialization and Provisioning functions.

The Media Access Control protocol supports multiple upstream channels. One of the available upstream channels shall be designated the Service Channel. It may be necessary to provide a Backup Service Channel to make the system more reliable e.g. in a noisy environment. The Service Channel and the Backup Service Channel, respectively, shall be used by NIU's entering the network via the Initialization and Provisioning procedure. The remaining upstream channels shall be used for upstream data transmission. In cases where only one upstream channel is utilized, the functions of the Service Channel shall reside in conjunction with regular upstream data transmission.

The Provisioning channel is the frequency channel on which the Default configuration message is transmitted. There can be several Provisioning channels in the system.

The Service channel is the frequency channel to which the Default configuration message field Service channel frequency points. The ranging following the Default configuration message is carried out on that Service channel. There can be several Service channels in the system.

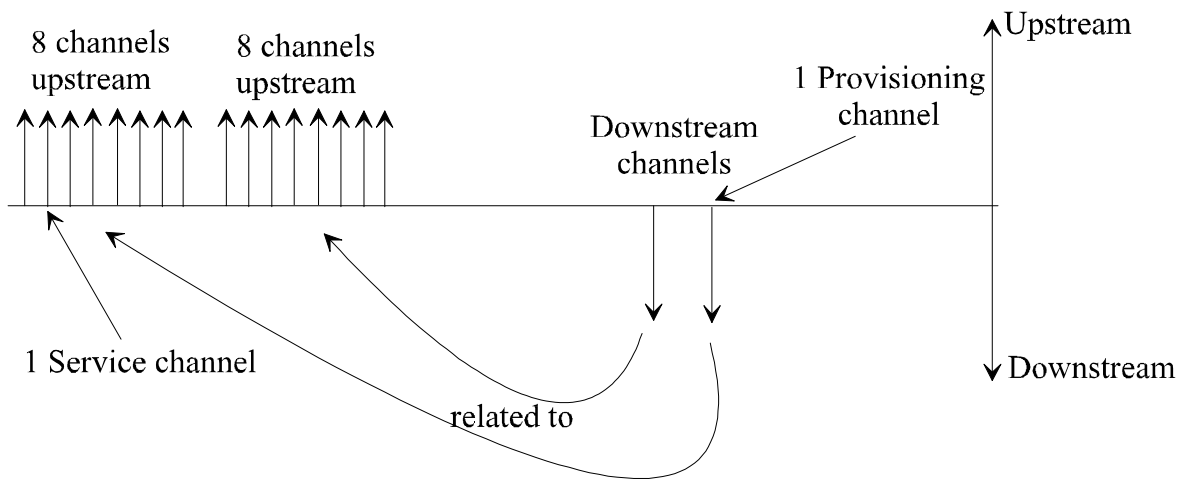

Figure 26: Example of a frequency allocation for the FDM scenario

Upstream frequency change

All connections of a NIU are on the same frequency channel. The upstream frequency can be changed by Reprovision or Transmission control message. If any of these messages change the frequency, the frequency is changed immediately, all connections remain established. After each frequency change, the sign-on procedure is entered (compare subclause 5.5.5). Reservation grants are lost, fixed rate slots are kept: If the frequency change was made by the <MAC> Transmission Control Message, the slot assignments remain the same. If the frequency change was made by the <MAC> Reprovision Message, the slot assignments remain the same except if new slot assignments are provided in this message.

Downstream frequency channel types

Table 15: Possible combinations of downstream content types and physical channels (NIU Capabilities)

Case	MAC		Data	
	OOB	IB	QPSK	QPSK IB
1	X		X	
2	X			X
3	X		X	X
4		X		X

There are three types of content in the downstream direction MAC messages and MAC flags, data and video. There can be two types of physical channels: QPSK and QPSK IB downstream channels. The QPSK IB downstream channel may carry either MPEG or MAC messages directly on the physical layer frame structure. The possible combinations of the content and physical channels are shown in the following table.

NOTE: The standard refers only to if frequencies as the RF frequency range will depend upon local regulations. therefore all the frequencies specified in the MAC messages are if frequencies as specified in subclause 5.1.2.

Combination establishment

The NIU tunes to either a QPSK or QPSK IB channel on which it locates the provisioning channel. The NIU tunes to it and gets its MAC information on that channel. If the Connect message gives a new downstream frequency, the MAC information is found on that frequency, if it is the same type of frequency channel.

Change of downstream frequency

The downstream frequency can be changed by using either Reprovision or Transmission control message. All NIU's connections which use the same physical frequency channel (DS QPSK or DS QPSK IB) are located on the same frequency. When the downstream frequency changes the connections on the earlier frequency remain established.

Change of combination

The combination can be changed with Connect message only immediately after the sign-on procedure or with Reprovision message at any time. The signalling channel cannot be changed to a different type of downstream channel.

5.5.2.3 Relationship Between Physical Layer Slot Position Counter and MAC Slot Assignment

M10 - M1 is a 10-bit superframe counter at the INA side, whereas the upstream slot position counter is an upstream slot counter at the NIUs side. The NIU slot position counter ($M10 - M1 \times 3 \times m = 6$ for 3,088 Mbit/s and $m = 12$ for 6,176 Mbit/s) may be implemented as a 16-bit counter which is compared to the 13-bit slot numbers assigned by the INA in MAC messages (list assignment). When the counter value equals any assigned value, the NIU is allowed to send a packet upstream.

5.5.2.4 Access Modes (Contention / Ranging / Fixed rate / Reservation)

Different access modes are provided to the NIUs within access regions specified by information contained in the slot boundary fields of the downstream superframes. The limits between access regions allow users to know when to send data on contention without risks of collision with data of Reservation or Fixed Rate regions. Also, the separation between reservation and fixed rate regions provides two ways of assigning slots to NIUs. The following rules define how to select access modes:

- Data connections:

When the INA assigns a connection ID to the NIU, it either specifies a slot list to be used (Fixed rate access) or the NIU shall use contention or reserved access by following this algorithm:

When the NIU shall send more cells for a specific VPI/VCI than what was assigned by the INA, it can use contention access only if the number of cells to transmit is less than `Maximum_contention_access_message_length` (specified in the MAC Connect Message from the INA). The details of the contention access mechanism is explained below under a). The NIU can send one request for reservation access if the number of cells is less than `Maximum_reservation_access_message_length` (specified in the MAC Connect Message from the INA). If more cells shall be transmitted, the NIU shall send multiple requests for reservation access. If the NIU/STB is forced to use reservation access, and it has not yet been assigned a `Reservation_ID`, then it shall wait for an assignment before transmitting.

- MAC messages:

MAC messages can be sent on contention access or reservation access.

Note that the VPI/VCI = 0/0x21 connection used for MAC messages is always set up, so the INA does not assign a particular connection ID which is normally used for reservation requests. Thus, in order to use reservation access, slots assigned for other connections may be used for MAC messages.

a) Contention Access

`Contention Access` indicates that data (MAC or bursty data traffic) is sent in the slots assigned to the contention access region in the upstream channel. It can be used either to send MAC messages or data. The VPI, VCI of the ATM cells are then used to determine the type and direction of the data in higher layers. Contention based access provides instant channel allocation for the NIU.

The Contention based technique is used for multiple subscribers that will have equal access to the signalling channel. It is possible that simultaneous transmissions occur in a single slot, which is called a collision. The INA utilizes the reception indicators to inform the NIU's whether successful reception of ATM cells has been obtained.

The NIU executes a separate contention process for each VPI/VCI connection that requires contention access. The contention process is initiated by transmitting the first cell in a contention slot. This contention slot is randomly chosen from the available contention slots in the first frame that contains at least one contention slot. The contention process has to wait until the reception indicator of the slot is received. If the indicator contains a positive acknowledgement, the cell has been successfully received, and the next cell, if present, can be transmitted by continuing the contention process. If the indicator contains a negative acknowledgement, a collision has been detected and the cell can be retransmitted according to the procedure defined below. If the reception indicator is not received (e.g. due to CRC error), the NIU proceeds as if a positive acknowledgement would have been received.

If a collision has occurred the NIU is not obliged to retransmit the cell that was originally transmitted. Instead it may choose to update the contents of the cell, transmit another cell belonging to the same VPI/VCI connection, or not to retransmit at all. In the latter case, the NIU is not allowed to restart a contention process for the same VPI/VCI connection at an earlier slot than the latest possible contention slot in which it could have retransmitted the cell in the first contention process. Note that the allowed choices make it possible for the NIU to update the queue status when the cell to be retransmitted is a grant request.

A counter at the NIU/STB records the number, denoted by `backoff_exponent`, of collisions encountered by a cell. The `backoff_exponent` counter starts from a value determined by the `Min_Backoff_Exponent` variable. The `backoff_exponent` is used to generate a uniform random number between 1 and $2^{\text{backoff_exponent}}$. This random number is used to schedule retransmission of the collided cell. In particular, the random number indicates the number of contention access slots the `HtmlResAnchor` NIU/STB shall wait before it transmits. The first transmission is carried out in a random cell within the contention based access region. If the counter reaches the maximum number, determined by the `Max_Backoff_Exponent` variable, the value of the counter remains at this value regardless of the number of subsequent collisions. After a successful transmission the `backoff_exponent` counter is reset to a value determined by the `Min_Backoff_Exponent` variable. Informational Statement: The random access algorithm is unstable; the INA is expected to have intelligence to detect an unstable state of the random access algorithm and to solve it.

For minislot contention resolution, see subclause 5.6.3.

b) Ranging Access

`Ranging access` indicates that the data is sent in a slot preceded and followed by slots not used by other users. These slots allow users to adjust their clock depending on their distance to the INA such that their slots fall within the correct allocated time. They are either in the ranging slots region when the ranging control slot indicator `b0` received during the previous superframe was 1 (or when `b1-b6 = 55 to 63`), or reserved if the INA indicates to the NIU that a specific slot is reserved for ranging (via the Ranging and Power Calibration Message). In the latter case, the NIU is forbidden from ranging in the ranging slots region before the assigned slot appears.

Simultaneous transmissions in ranging slots are resolved through the procedure defined in Figure A.1.

c) Fixed rate Access

NOTE: Fixed rate is called contentionless in DAVIC.

`Fixedrate_Access` indicates that data is sent in slots assigned to the fixed rate based access region in the upstream channel. These slots are uniquely assigned to a connection by the INA.

d) Reservation Access

`Reservation Access` implies that data is sent in the slots assigned to the reservation region in the upstream channel. These slots are uniquely assigned once to a connection by the INA. This assignment is made at the request of the NIU for a given connection. It is also allowed to use such assignment in the fixed rate region.

5.5.2.5 MAC Error Handling Procedures

Error handling procedures are under definition (Time out windows, power outage, etc.)

5.5.2.6 MAC Messages in the Mini Slots

MAC reservation request messages may also be transported in the minislot structure. The Start Field (SF) for the MAC messages is defined in subclause 5.6.2. Error correction and/or detection is performed using a 2 byte Reed Solomon code.

Reed-Solomon encoding shall be performed on the 14 bytes following the Unique Word with $T = 1$. This process adds 2 parity bytes to the MAC Message in the Minislot to give a code word of (16,14). Reed-Solomon encoding is performed on the MAC Message in the Minislot before upstream data randomization. The shortened Reed-Solomon code shall be implemented by appending 239 bytes, all set to zero, before the information bytes at the input of a (255,253) encoder; after the coding procedure these bytes are discarded.

The Reed-Solomon code shall have the following generator polynomials:

Code Generator Polynomial: $g(x) = (x + \mu^0)(x + \mu^1)$,

where $\mu = 02\text{hex}$.

Field Generator Polynomial: $p(x) = x^8 + x^4 + x^3 + x^2 + 1$.

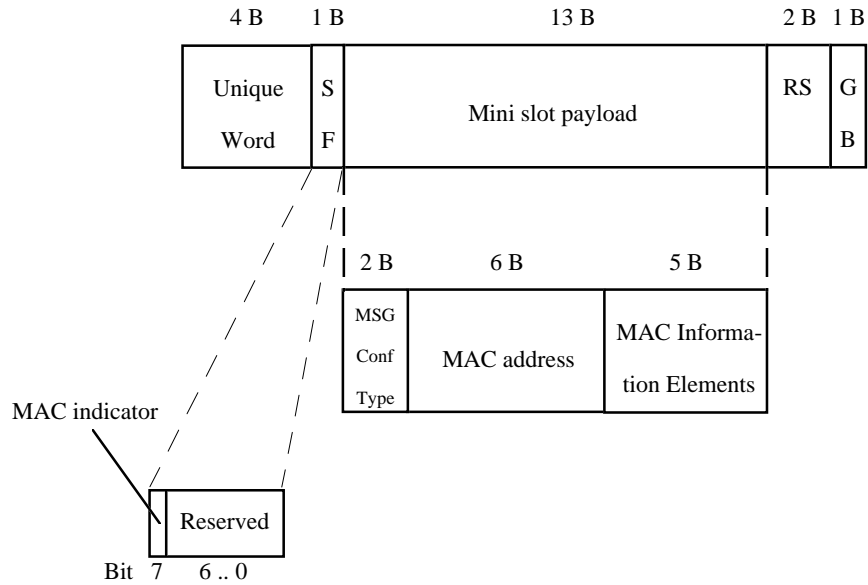

Figure 27: MAC messages in the minislots

Unique Word = 0x00 FC FC F3

SF = Start Field (Bit 7: MAC indicator, always set to 1; Bit 6..0: reserved, shall be set to zero)

RS = Reed Solomon Bytes

GB = Guard Band

Reservation Request Message

The Reservation Request Message has the same structure as in the case it is transported in the upstream ATM slot. The MAC message structure for carrying the Reservation Request Message is shown in Figure 28.

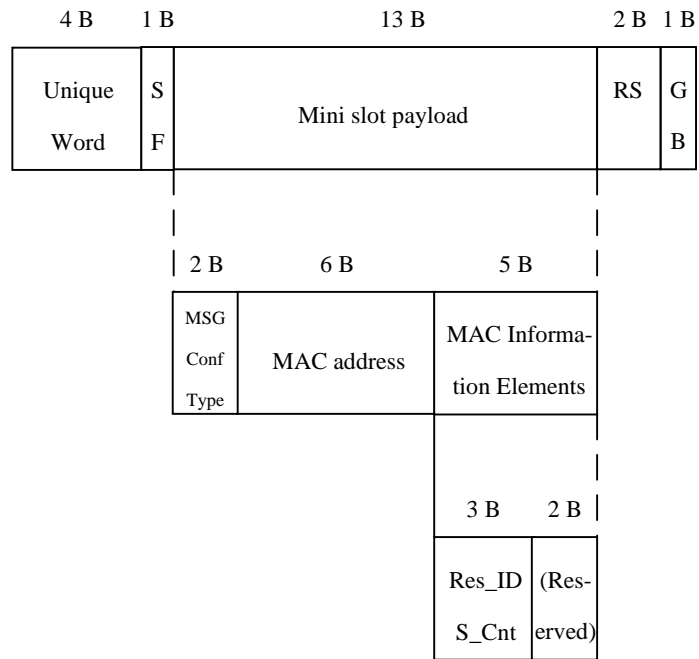

Figure 28: Reservation Request Message in the minislot MAC message structure

5.5.2.7 MAC Message Format

The MAC message types are divided into the logical MAC states of Initialization, Sign On, Connection Management and Link Management. Messages in *Italic* represent upstream transmission from NIU to INA. MAC messages are sent using Broadcast or Singlecast Addressing. Singlecast address shall utilize the 48-bit MAC address.

Table 16: MAC messages

Message Type Value		Addressing Type
	MAC Initialization, Provisioning and Sign-On Messages	
0x00	Used for fragmented messages (continued message) (see note)	Scast or Bcast
0x01	Provisioning Channel Message	Broadcast
0x02	Default Configuration Message	Broadcast
0x03	Sign-On Request Message	Broadcast
0x04	Sign-On Response Message	Singlecast
0x05	Ranging and Power Calibration Message	Singlecast
0x06	Ranging and Power Calibration Response Message	Singlecast
0x07	Initialization Complete Message	Singlecast
0x08-0x0B	[Reserved]	
0x0C	Security Sign-on (see note)	Singlecast
0x0D	Security Sign-on Response (see note)	Singlecast
0x0E-0x1E	[Reserved]	
0x1F	Wait (see note)	Singlecast
	MAC Connection Establishment and Termination Msgs	
0x20-0x3F		
0x20	Connect Message	Singlecast
0x21	Connect Response Message	Singlecast
0x22	Reservation Request Message	Singlecast
0x23	Unused	Broadcast
0x24	Connect Confirm Message	Singlecast
0x25	Release Message	Singlecast
0x26	Release Response Message	Singlecast
0x28	Reservation Grant Message	Broadcast
0x29	Reservation ID Assignment	Singlecast
0x2A	Reservation Status Request	Singlecast
0x2B	Reservation ID Response Message	Singlecast
0x2C	Resource Request Message	Singlecast
0x2D	Resource Request Denied Message	Singlecast
0x2E-0x2F	[Reserved]	
0x30	Main Key Exchange (see note)	Singlecast
0x31	Main Key Exchange Response (see note)	Singlecast
0x32	Quick Key Exchange (see note)	Singlecast
0x33	Quick Key Exchange Response (see note)	Singlecast
0x34	Explicit Key Exchange (see note)	Singlecast
0x35	Explicit Key Exchange Response (see note)	Singlecast
0x36-0x3F	[Reserved]	
	MAC Link Management Messages	
0x27	Idle Message	Singlecast
0x40	Transmission Control Message	Scast or Bcast
0x41	Reprovision Message	Singlecast
0x42	Link Management Response Message	Singlecast
0x43	Status Request Message	Singlecast
0x44	Status Response Message	Singlecast
0x45-0x5F	[Reserved]	
NOTE: Optional MAC messages for the security option.		

To support the delivery of MAC related information to and from the NIU, a dedicated Virtual Channel shall be utilized. The VPI,VCI for this channel shall be 0x000,0x0021.

The timer accuracy of the MAC messages shall be ± 3 ms in the NIU, and the INA shall take this into account.

- Upstream MAC messages:

AAL5 (as specified in ITU-T Recommendation I.363 [8]) adaptation shall be used to encapsulate each MAC PDU in an ATM cell. Upstream MAC information should be single 40 bytes cell messages.

- Downstream OOB MAC messages:

AAL5 (as specified in ITU-T Recommendation I.363 [8]) adaptation shall be used to encapsulate each MAC PDU in an ATM cell. Downstream OOB MAC information may be longer than 40 bytes. All Downstream MAC messages shall be restricted to less than or equal to 120 bytes.

- Downstream IB MAC messages:

Downstream IB MAC messages are limited to a size of 120 bytes and shall be carried in a single TS packet. Longer messages shall be split into separate messages. No AAL5 layer is defined for MPEG-2 TS cells. MAC messages shall therefore be sent as explained in subclause 5.3.2 using the three MAC Message Framing bits.

- MAC Fragmentation Protocol (optional):

Larger security MAC messages up to 512 bytes may optionally be supported using the MAC fragmentation protocol. This capability is indicated by the NIU in the MAC_Sign_On_Response.

A multi-fragment MAC message is composed of consecutive individual MAC messages with Syntax_Indicator equal to Fragment_No_MAC_Address or Fragment_MAC_Address_Included.

The Fragment_Count field of each individual MAC message indicates the number of fragments remaining of the full message, decreasing by one for each consecutive fragment. Thus the first fragment has Fragment_Count equal to the total number of fragments in the message, and the last fragment has Fragment_Count == 1.

Furthermore, the type of MAC message is indicated by the Message_Type field of the first fragment, whereas all subsequent fragments have Message_Type == 0.

The sender of a fragmented MAC message shall not interleave any other fragmented MAC messages for the same receiver into the string of fragments. This includes any fragmented broad-cast MAC messages, which shall therefore not be sent while there are any incomplete fragmented messages outstanding.

MAC messages of unfragmented syntax type can be interleaved with fragments destined for the same NIU. They are deemed to have arrived before the fragmented message, and should be processed immediately.

The receiver of a fragmented MAC message shall discard any message with missing fragments, as implied by the uniformly decreasing Fragment_Count field in consecutive fragments. Likewise, it shall discard any stray fragments with Message_Type == 0, for instance in the case where the first fragment was lost during transport.

The length of each fragment is implied by its transport context: ATM/AAL-5 for upstream and OOB downstream, MPEG encapsulation for IB downstream, etc.

The MAC_Information_Elements fields of each fragment are concatenated to form the MAC_Information_Elements field of the full MAC message. The message type is conveyed in the first fragment.

In the upstream direction, all fragments shall be of syntax type Fragment_MAC_Address_Included, in order to allow the INA to use the MAC address to distinguish inter-mixed MAC messages and fragments coming from separate NIUs.

For a broad-cast in the downstream direction, each fragment is of syntax type Fragment_No_MAC_Address. For a single-cast downstream message, the first fragment shall be of syntax type Fragment_MAC_Address_Included, and include the MAC address of the target NIU. Subsequent fragments can also include the same MAC address value, or can be Fragment_No_MAC_Address, omitting the MAC address, when the INA ensures that the fragment is associated with the immediately preceding fragment in the transport stream, that is, not separated by messages or fragments for other NIUs.

Since MAC related information is terminated at the NIU and INA, a privately defined message structure will be utilized. The format of this message structure is illustrated below.

NOTE 1: All messages are sent most significant bit first.

NOTE 2: For all MAC messages where the parameter length is smaller than the field, the parameter shall be right justified with leading bits set to 0. All reserved fields in the MAC messages shall be set to 0.

NOTE 3: Message 0x23 is not used in the present release of the MAC protocol. It refers to DAVIC 1.0 protocol which is not supported by the present document.

NOTE 4: When no MAC_Address is specified in the message, it means that the message is sent broadcast. (Syntax_indicator = 000).

NOTE 5: Negative integers are sent in 2's complement.

Table 17: MAC message structure

MAC_message () {	Bits	Bytes	Bit Number / Description
Message_Configuration		1	
Protocol_Version	5		
Syntax_Indicator	3		
Message_Type	8	1	
if (Syntax_Indicator == 001 Syntax_Indicator == 011) {			
MAC_Address	(48)	(6)	
}			
if (Syntax_Indicator == 010 Syntax_Indicator == 011) {			
Fragment_Count	(8)	(1)	
}			
MAC_Information_Elements ()		N	
}			

MAC Information Elements

MAC_Information_Elements is a multiple byte field that contains the body of one and only one MAC message.

Protocol Version

Protocol_Version is a 5-bit field used to identify the current MAC version. The value for this parameter is given in the following table.

Table 18: Protocol_version coding

Value	Definition
0	DAVIC 1.0 Compliant device (not consistent with the present document)
1	DAVIC 1.1 Compliant device
2	DAVIC 1.2 Compliant device
3 - 19	Reserved
20	EN 301 199 compliant device
21 - 28	Reserved
29	ETS 300 800 [2] V2 compliant device
30	ETS 300 800 [2] V1 compliant device
31	Reserved

Syntax Indicator

`Syntax_Indicator` is a 3-bit enumerated type that indicates the addressing type contained in the MAC message.

```
Enum Syntax_Indicator {No_MAC_Address, MAC_Address_Included, Fragment_No_MAC_Address,
Fragment_MAC_Address, reserved 4...7};
```

MAC Address

`MAC_Address` is a 48-bit value representing the unique MAC address of the NIU. This MAC address may be hard coded in the NIU or be provided by external source.

Fragment_Count

Identification of fragment in a MAC message transmitted in multiple fragments. A MAC Message divided into N fragments, will be transmitted with `Fragment_Count` = N, N-1, ... 1.

5.5.3 MAC Initialization and Provisioning

This subclause defines the procedure for Initialization and Provisioning that the MAC shall perform during power on or Reset.

- 1) Upon a NIU becoming active (i.e. powered up), it shall first find the current provisioning frequency. The NIU shall receive the **<MAC> Provisioning Channel Message**. This message shall be sent aperiodically on all downstream channels carrying MAC information when there are multiple channels. In the case of only a single channel, the message shall indicate the current channel is to be utilized for Provisioning. Upon receiving this message, the NIU shall tune to the Provisioning Channel. In the case of IB downstream, the IB channel to be used during provisioning shall be given by using ETS 300 468 [6].
- 2) After a valid lock indication on a Provisioning Channel, the NIU shall await the **<MAC> DEFAULT CONFIGURATION MESSAGE**. When received, the NIU shall configure its parameters as defined in the default configuration message. The Default Configuration Parameters shall include default timer values, default power levels, default retry counts as well as other information related to the operation of the MAC protocol.

Figure 29 shows the signalling sequence.

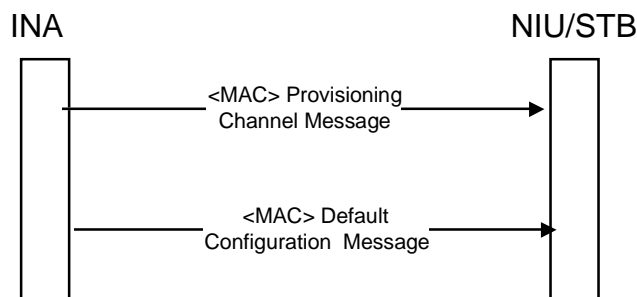

Figure 29: Initialization and Provisioning signalling

5.5.3.1 <MAC> Provisioning Channel Message (Broadcast OOB Downstream)

The <MAC> PROVISIONING CHANNEL MESSAGE is sent by the INA to direct the NIU to the proper frequency where provisioning is performed. The format of the message is shown in the following table.

Table 19: Provisioning Channel Message Structure

Provisioning_Channel_Message (){	Bits	Bytes	Bit Number / Description
Provisioning_Channel_Control_Field	8	1	
Reserved	7		7 - 1
Provisioning_Frequency_Included	1		0: {no = 0, yes = 1}
<i>if</i> (Provisioning_Frequency_Included) {			
Provisioning_Frequency	(32)	(4)	
DownStream_Type	(8)	(1)	
}			
}			

Provisioning Channel Control Field

Provisioning_Channel_Control_Field is used to specify which parameters are included in the message:

Provisioning_Frequency_Included is a Boolean when set, indicates that a downstream frequency is specified that the NIU should tune to begin the provisioning process. When cleared, indicates that the current downstream frequency is the provisioning frequency.

Provisioning Frequency

Provisioning_Frequency is a 32-bit unsigned integer representing the Out-of-band Frequency in which NIU provisioning occurs. The unit of measure is Hz.

Downstream Type

DownStream_Type is an 8-bit enumerated type indicating the modulation format for the down stream connection. {QPSK IB, reserved, QPSK_3,088, 3...255 reserved}}

5.5.3.2 <MAC> Default Configuration Message (Broadcast Downstream)

The <MAC> DEFAULT CONFIGURATION MESSAGE is sent by the INA to the NIU. The message provides default parameter and configuration information to the NIU. The format of the message is shown in the following table.

Table 20: Default configuration message structure

Default_Configuration_Message (){	Bits	Bytes	Bit Number / Description
Sign_On_Incr_Pwr_Retry_Count	8	1	
Service_Channel_Frequency	32	4	
Service_Channel_Control_Field		1	
MAC_Flag_Set	5		7..3
Service_Channel	3		2..0
Backup_Service_Channel_Frequency	32	4	
Backup_Service_Channel_Control_Field		1	
Backup_MAC_Flag_Set	5		7..3
Backup_Service_Channel	3		2..0
Service_Channel_Frame_Length	16	2	
Service_Channel_Last_Slot	16	2	
Max_Power_Level	8	1	
Min_Power_Level	8	1	
Upstream_Control_Field		1	
Reserved	5		7..3
Upstream_Transmission_Rate	3		2..0
Max_Backoff_Exponent	8	1	
Min_Backoff_Exponent	8	1	
Idle_Interval	16	2	
Absolute_Time_Offset	16	2	
frequency-ranging_step	8	1	
Number_of_Timeouts	8	1	
for (I=0; I<Number_of_Timeouts;I++) {			
Field		(1)	
Code	(4)		
Value	(4)		
}			
INA_Capabilities		4	
Encapsulation	8		31..24
US_Bitrate	8		23..16
DS_OOB_Bitrate	4		15..12
Reserved	5		11..7
Resource_Request_Capable	1		6: {no, yes}
Fragmented_MAC_Messages	1		5: {no, yes}
Security_Supported	1		4: {no, yes}
Minislots_for_Reservation	1		3: {no, yes}
Reserved_for_DAVIC	1		2: shall be 0
IB_Signalling	1		1: {no, yes}
OOB_Signalling	1		0: {no, yes}
}			

Sign-On Increment Power Retry Count

Sign_On_Incr_Pwr_Retry_Count is an 8-bit unsigned integer representing the number of attempts the NIU should try to enter the system at the same power level before incrementing its power level by steps of max. 2 dB.

Service Channel Frequency

Service_Channel_Frequency is a 32-bit unsigned integer representing the upstream frequency assigned to the service channel. The unit of measure is in Hz.

MAC_Flag_Set

MAC_Flag_Set is a 5-bit field representing the first HtmlResAnchor MAC Flag set assigned to the service channel. A downstream channel contains information for each of its associated upstream channels. This information is contained within structures known as MAC Flag Sets represented by either 24 bits (denoted b0...b23) or by 3 bytes (denoted Rxa, Rxb, Rxc). This information is uniquely assigned to a given upstream channel. See subclauses 5.3.1.3 and 5.3.2.1 for the use of this parameter.

Service_Channel

Service_Channel is a 3-bit field which defines the channel assigned to the Service_Channel_Frequency. It identifies the logical channel (denoted by "c") assigned to the NIU/STB. See subclauses 5.3.2.1 and 5.3.3 for the use of this parameter.

Backup_Service_Channel_Frequency

Backup_Service_Channel_Frequency is a 32-bit unsigned integer representing the upstream frequency assigned to the backup service channel. The backup service channel is used when entry on the primary service channel fails. The unit of measure is in Hz. If there is no Backup Service Channel, this parameter shall be equal to the Service Channel Frequency.

Backup_MAC_Flag_Set

Backup_MAC_Flag_Set is a 5-bit field representing the first HtmlResAnchor MAC Flag set assigned to the backup service channel. The function of this field is the same as the MAC_Flag_Set above but with respect to the backup service channel. If there is no Backup Service Channel, this parameter shall be equal to the MAC Flag Set.

Backup_Service_Channel

Backup_Service_Channel is a 3-bit field which defines the channel assigned to the Backup Service_Channel_Frequency. The function of this field is the same as the Service_Channel above but with respect to the backup channel. If there is no Backup Service Channel, this parameter shall be equal to the Service Channel.

Service_Channel_Frame_Length [reserved]

Unused in this version.

Service_Channel_Last_Slot

Service_Channel_Last_Slot is a 16-bit unsigned integer representing the largest slot value of the NIU's upstream slot position counter (as defined in subclause 5.4.4).

Only 13 lowest significant bits shall be considered. 3 MSB are reserved for future used.

NOTE: Since the value of Service_Channel_Last_Slot equals $((N+1) \times 3 \times m) - 1$, where "N" is the maximum value of the upstream slot position register (M10-M1), and "m" is a constant dependent upon the upstream bit rate, (see subclause 5.4.4), one may use it to calculate N.

Maximum Power Level

MAX_Power_Level is a 8-bit unsigned integer representing the maximum power the NIU shall be allowed to use to transmit upstream. The unit of measure is in dB μ V (RMS) on 75 Ω .

Minimum Power Level

MIN_Power_Level is an 8-bit unsigned integer representing the minimum power the NIU shall be allowed to use to transmit upstream. The unit of measure is in dB μ V (RMS) on 75 Ω .

Upstream Transmission Rate

Upstream_Transmission_Rate is a 3-bit enumerated type that indicates the upstream transmission bit rate.

```
enum Upstream_Transmission_Rate {Reserved, Reserved, Upstream_3-088M, reserved3...7};
```

MIN_Backoff_Exponent

`MIN_Backoff_Exponent` is an 8-bit unsigned integer representing the minimum value of the backoff exponent counter.

MAX_Backoff_Exponent

`MAX_Backoff_Exponent` is an 8-bit unsigned integer representing the maximum value of the backoff exponent counter. Only the 5 least significant bits are valid, the 3 most significant bits are reserved for future use.

Idle_Interval

`Idle_Interval` is a 16-bit unsigned integer representing the predefined interval for the MAC Idle Messages. The unit of the measure is in seconds. The value of zero indicates that no Idle messages shall be sent.

Absolute_Time_Offset

`Absolute_Time_Offset` is a 16-bit signed integer used to set the default `Absolute_Time_Offset` (defined in subclause 5.3.1.3) when first signing on. The unit of measure is 100 ns.

Frequency Ranging Step

`Frequency_ranging_step` is an 8-bit unsigned integer used to set the frequency step value for frequency ranging. The unit of measure is the kHz; the default value is 50 kHz.

Timeouts**Number_of_Timeouts**

`Number_of_Timeouts` is a 8-bit unsigned integer which identifies the number of timeout codes and values included in the message.

Code

`Code` is a 4-bit unsigned integer which identifies the timeout or group of timeouts (according to Table 21, Table 22 and Table 51) for which the following value is given.

Value

`Value` is a 4-bit unsigned integer which gives the value for the timeout or group of timeouts identified by the preceding code. The timeout can be derived from the following table:

Table 20a

Value	Timeout (ms)
0	Infinite (disabled)
1	9
2	30
3	60
4	90
5	300
6	600
7	900
8	3 000
9	6 000
10	9 000
11	30 000
12	60 000
13	reserved
14	reserved
15	reserved

The value shall be between the Min Value and the Max Value given in Table 21, Table 22 and Table 51 (if specified). If no values are given in the <MAC> Default Configuration Message, the default values apply.

Table 21: Head-end Timeout Values

Code	Transaction(s)	Default Value
0x0	Ranging and power calibration -> Ranging and power calibration response Connect -> Connect response (no frequency change) Release -> Release response Transmission control -> Link management response (no frequency change) Reservation ID assignment -> Reservation ID response Reprovision -> Link management response (no frequency change) Status request -> Status response message Init complete -> Connect response Init. complete -> Link management response	300
0x1	Connect -> Sign on response (only for frequency change) Reprovision -> Sign on response (only for frequency change) Transmission control -> Sign on response (only for frequency change)	3 000

The Unit for the timeouts is ms.

These timeouts apply when the mentioned two messages are consecutive.

Table 22: Terminal Timeout Values

Code	Transaction(s)	Default Value
0x2	Default configuration interval(time between two Def. Conf. msg) Sign on request interval	900
0x3	Sign on response -> Ranging and power calibration Sign on response -> Initialization complete Ranging and power calibration response -> Ranging and power calibration Ranging and power calibration response -> Initialization complete Connect response -> Connect confirm Resource Request -> Release Resource Request -> Reservation_ID assignment	90
0x4	Initialization complete -> Connect Resource Request -> Resource Request Denied Resource Request -> Connect Resource Request -> Reprovision	300

The Unit for the timeouts is ms.

These timeouts apply when the mentioned two messages are consecutive.

INA_Capabilities

INA_Capabilities is a 32-bit field that indicates the capabilities of the INA. It has the following subfields:

Encapsulation is an 8-bit field that indicates the type(s) of encapsulation supported by the INA: {DIRECT_IP, Ethernet_MAC_Bridging, PPP, reserved 3...7}

US_Bitrate is an 8-bit field that indicates the upstream bitrate(s) supported by the INA: {reserved, reserved, 3,088 Mbit/s, 6,176 Mbit/s, reserved 4...7}

DS_OOB_Bitrate is a 4-bit field that indicates the downstream OOB bitrate(s) supported by the INA: {3,088 Mbit/s, reserved 2...3}

Reserved: Reserved for future use

Resource_Request_Capable is a 1-bit field that indicates if the INA is able to process <MAC> Resource Request Messages.

`Fragmented_MAC_Messages` is a 1-bit field that indicates that the INA is able to support MAC messages having the compound `MAC_Information_Elements` field of a single up to 512 bytes in size. This flag is also for backwards compatibility with INAs not supporting MAC message fragmentation and re-assembly. By not setting this bit, the INA indicates that it does not support fragmented MAC messages at all, and will not understand or utilize the `Fragment_No_MAC_Address` and `Fragment_MAC_Address_Included` MAC message syntax types.

`Security_Suported` is a 1-bit field that indicates that the INA is able to support the security extensions specified in this protocol.

`Minislots_for_Reservation` is a 1-bit field that indicates that the INA is capable of utilizing minislots.

`Reserved_for_DAVIC`: Reserved for compatibility with DAVIC.

`IB_Signalling` is a 1-bit field that indicates that the INA is capable of utilizing IB signalling.

`OOB_Signalling` is a 1-bit field that indicates that the INA is capable of utilizing OOB signalling.

5.5.4 Sign On and Calibration

The NIU shall Sign On via the Sign-On Procedure. The signalling flow for Sign-On is described below.

- The NIU shall tune to the downstream Provisioning channel and the upstream service channel with the information provided in the Initialization and Provisioning sequence.
- The NIU shall await the **<MAC> Sign-On Request Message** from the INA Entity.
- Upon receiving the **<MAC> Sign-On Request Message**, the NIU shall respond with the **<MAC> Sign-On Response Message**. The Sign-On Response Message shall be transmitted on a Ranging Slot. The NIU/STB shall either use settings of the last successful Sign-on procedure if it is enabled by the INA or the `Min_Power_Level` contained in the **<MAC> Default Configuration Message**.
- The INA, upon receiving the Sign-On Response Message shall validate the NIU, either sending **<MAC> Initialization Complete Message** or the **<MAC> Ranging and Power Calibration Message**.
- The NIU shall respond to the **<MAC> Ranging and Power Calibration Message** with the **<MAC> Ranging and Power Calibration Response Message**. The **<MAC> Ranging and Power Calibration Response Message** shall be transmitted on a Ranging Slot (which can either be in the ranging region (`b0 = 1`) or reserved region (if a ranging slot number is given in the message). The calibration sequence is not always necessary.
- The INA shall send the **<MAC> Initialization Complete Message** when the NIU is calibrated. The NIU is assumed to be calibrated if the message arrives within a window of $\pm 0,75$ symbols (upstream rate) and a power within a window of $\pm 1,5$ dB from their optimal value.

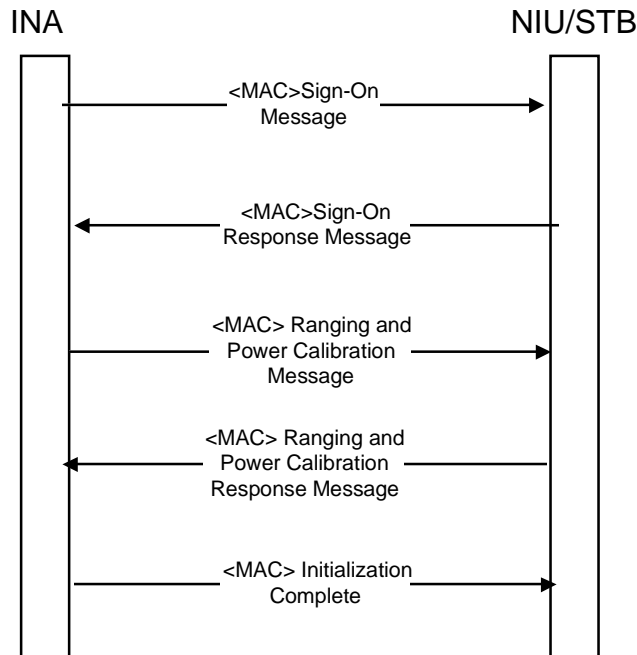

Figure 30: Ranging and Calibration Signalling

A more detailed description of the ranging and calibration process, including state diagrams and time outs, is given in Annex A.

5.5.4.1 <MAC> Sign-On Request Message (Broadcast Downstream)

The <MAC> Sign-On Request message is issued periodically by the INA to allow a NIU to indicate its presence in the network. The format of this subcommand is shown in the following table.

Table 23: Sign-On Request Message Structure

Sign-On_Request_Message (){	Bits	Bytes	Bit Number / Description
Sign-On_Control_Field		1	
Reserved	6		7..2
Need_Calibration	1		1: {0 = enable rapid sign-on, 1 = disable rapid sign-on}
Address_Filter_Params_Included	1		0: {no, yes}
Response_Collection_Time_Window	16	2	
<i>if (Sign-On_Control_Field &= Address_Filter_Params_Included {</i>			
Address_Position_Mask	(8)	(1)	
Address_Comparison_Value	(8)	(1)	
<i>}</i>			
}			

Sign-On Control Field

Sign-On_Control_Field specifies what parameters are included in the SIGN-ON REQUEST:

Need_Calibration indicates to the NIU that it has to enter the sign-on process starting with the Min_Power_Level and Absolute_Time_Offset (and Frequency_Offset for LMDS) defined in the <MAC> Default_Configuration_message. This bit is not to be taken into account the first time the NIU engages the sign-on process after power on, in this case it always starts with the parameters defined in the <MAC> Default_Configuration_message.

Address_Filter_Params_Included is a Boolean, when set, indicates that the NIU should respond to the SIGN-ON REQUEST only if its address matches the filter requirements specified in the message.

Response Collection Time Window

`Response_Collection_Time_Window` is a 16-bit unsigned integer that specifies the maximum time for the SIGN-ON RESPONSE message transmission randomization. The unit of measure is the millisecond (ms).

Address Position Mask

`Address_Position_Mask` is an 8-bit unsigned integer that indicates the bit positions in the NIU MAC address that are used for address filtering comparison. The bit positions are comprised between bit number `Mask` and `Mask+7`. `Mask = 0` corresponds to the 8 LSBs of the address, i.e., it represents the number of bits shifted to the left. The maximum value is 40.

Address Comparison Value

`Address_Comparison_Value` is an 8-bit unsigned integer that specifies the value that the NIU should use for MAC address comparison.

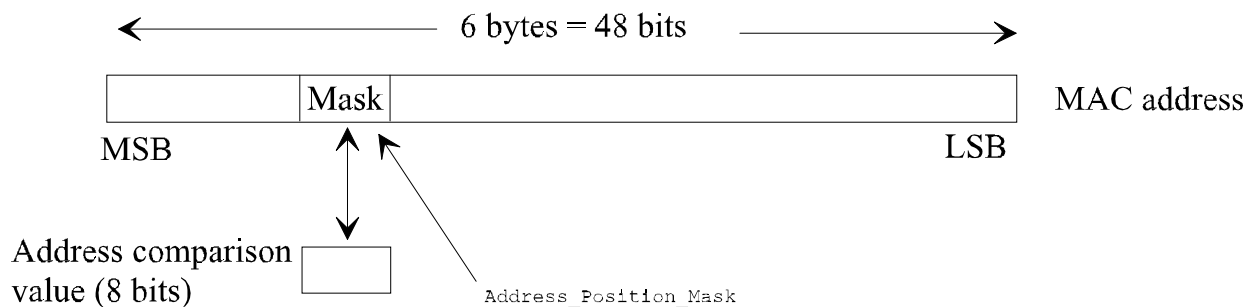

Figure 31: Position of Mask in MAC address

5.5.4.2 <MAC> Sign-On Response Message (Upstream Ranging)

The <MAC> Sign-On Response Message is sent by the NIU in response to the <MAC> Sign-On Request Message issued by the INA Entity. The NIU shall wait for a random time less than `Response_Collection_Time_Window` to send this message.

If the sign-on procedure did not start at the `Min_Power_Level` (see subclause 5.5.4), when the NIU has not received any response from the INA after `Sign_On_Incr_Pwr_Retry_Count` attempts, it shall retry with the `Min_Power_Level`.

Table 24: Sign-On response Message structure

Sign-On_Response_Message (){	Bits	Bytes	Bit Number / Description
NIU/STB_Status		4	
Reserved	29		31..3
Network_Address_Registered	1		2: {no, yes}
Connection_Established	1		1: {no, yes}
Reserved	1		0
NIU/STB_Error_Code		2	
Reserved	13		15..3
Connect_Confirm_Timeout	1		2: {no, yes}
First_Connection_Timeout	1		1: {no, yes}
Range_Response_Timeout	1		0: {no, yes}
NIU/STB_Retry_Count	8	1	
NIU/STB_Capabilities		4	
Encapsulation	8		31..24
US_Bitrate	8		23..16
DS_OOB_Bitrate	4		15..12
Reserved	5		11..7: {no, yes}
Resource_Request_Capable	1		6: {no, yes}
Fragmented_MAC_Messages	1		5: {no, yes}
Security_Supported	1		4: {no, yes}
Minislots_for_Reservation	1		3: {no,yes}
Reserved_for_DAVIC	1		2: shall be zero
IB_Signalling	1		1: {no, yes}
OOB_Signalling	1		0: {no, yes}
}			

NIU/STB_Status

NIU/STB_Status is a 32-bit field that indicates the current state of the NIU/STB. It has the following subfields:

Network_Address_Registered indicates that the Network Interface Module has registered its NSAP Address with the Application Module. The NSAP Address is not currently used but remains reserved for this purpose.

Connection_Established indicates that the Network Interface Module has been assigned Connection parameters.

NIU/STB_Error_Code

NIU/STB_Error_Code is an 16-bit field that indicates the error condition within the NIU/STB. It has the following subfields:

Connect_Confirm_Timeout (set to 1 for transition SCE:E4 or DCE:E8)

First_Connection_Timeout (set to 1 for transition DCE:E2)

Range_Response_Timeout (set to 1 for transition RC:E13, Figure A.1)

In case of a timeout in the current signalling, the corresponding subfield is set to one (Annex A).

NIU/STB_Retry_Count

NIU/STB_Retry_Count is a 8-bit unsigned integer that indicates the number of transmissions of the <MAC> Sign-On Response. This field is always included in the response to the <MAC> Sign-On Request. This field shall be initialized to zero whenever a Sign-On procedure is started, and this field shall be incremented by one each time the message is transmitted until the Sign-On procedure completes or the value reaches its maximum value (255). In the case that this field reaches its maximum value, it shall remain at the maximum value for the remainder of the current Sign-On procedure.

NIU/STB_Capabilities

NIU/STB_Capabilities is a 32-bit field that indicates the capabilities of the NIU/STB. It has the following subfields:

Encapsulation is an 8-bit field that indicates the type(s) of encapsulation supported by the NIU/STB: {DIRECT_IP, Ethernet_MAC_Bridging, PPP, reserved 3...7}

US_Bitrate is an 8-bit field that indicates the upstream bitrate(s) supported by the NIU/STB: {reserved, reserved, 3,088 Mbit/s, 6,176 Mbit/s, reserved 4...7}

DS_OOB_Bitrate is a 4-bit field that indicates the downstream OOB bitrate(s) supported by the NIU/STB: {3,088 Mbit/s, reserved 2...3}

Reserved: Reserved for future use

Resource_Request_Capable is a 1-bit field that indicates if the NIU is able to send <MAC> Resource Request Messages.

Fragmented_MAC_Messages is a 1-bit field that indicates that the NIU/STB is able to support MAC messages having the compound MAC_Information_Elements field of a single up to 512 bytes in size. This flag is also for backwards compatibility with NIU/STBs not supporting MAC message fragmentation and re-assembly. By not setting this bit, the NIU/STB indicates that it does not support fragmented MAC messages at all, and will not understand or utilize the Fragment_No_MAC_Address and Fragment_MAC_Address_Included MAC message syntax types.

Security_Supported is a 1-bit field that indicates that the NIU/STB is able to support the security extensions specified in this protocol.

Minislots_for_Reservation is a 1-bit field that indicates that the NIU/STB is capable of utilizing minislots.

Reserved_for_DAVIC: Reserved for compatibility with DAVIC.

IB_Signalling is a 1-bit field that indicates that the NIU/STB is capable of utilizing IB signalling.

OOB_Signalling is a 1-bit field that indicates that the NIU/STB is capable of utilizing OOB signalling.

5.5.4.3 <MAC> Ranging and Power Calibration Message (Singlecast Downstream)

The <MAC> RANGING AND POWER CALIBRATION MESSAGE is sent by the INA to the NIU to adjust the power level or time offset the NIU is using for upstream transmission. The format of this message is shown in the following table. Minislots are not used for ranging.

Table 25: Ranging and Power Calibration Message structure

Ranging_and_Power_Calibration_Message (){	Bits	Bytes	Bit Number / Description
Range_Power_Control_Field		1	
Reserved	5		7-3:
frequency_adjustment_included	1		3: {no, yes}
Ranging_Slot_Included	1		2: {no, yes}
Time_Adjustment_Included	1		1: {no, yes}
Power_Adjustment_Included	1		0: {no, yes}
<i>if (Range_Power_Control_Field &= Time_Adjustment_Included) {</i>			
Time_Offset_Value	(16)	(2)	
<i>}</i>			
<i>if (Range_Power_Control_Field &= Power_Adjustment_Included) {</i>			
Power_Control_Setting	(8)	(1)	
<i>}</i>			
<i>if (Range_Power_Control_Field &= Ranging_Slot_Included) {</i>			
Ranging_Slot_Number	(16)	(2)	
<i>}</i>			
<i>if (range_frequency_control-field = = frequency_adjustment_included) {</i>			
Frequency_Offset_Value	(32)	(4)	
<i>}</i>			
<i>}</i>			

Range and Power Control Field

Range_Power_Control_Field specifies which Range and Power Control Parameters are included in the message.

Frequency Adjustment Included

frequency_adjustment_included is a Boolean when set, indicates that a relative upstream frequency offset value is included that the NIU should use to adjust its upstream IF frequency.

Time Adjustment Included

time_adjustment_included is a Boolean when set, indicates that a relative Time Offset Value is included that the NIU should use to adjust its upstream slot transmit position.

Power Adjust Included

power_adjust_included is a Boolean when set, indicates that a relative Power Control Setting is included in the message

Ranging Slot Included

Ranging_Slot_Included is a Boolean when set, indicates the calibration slot available. When this bit equals 1, the NIU shall send its response on the slot number given by **Ranging Slot Number**. When this bit equals 0, the NIU shall respond on a ranging slot as mentioned in Figure A.1.

Time Offset Value

Time_Offset_Value is a 16-bit short integer representing a relative offset of the upstream transmission timing. A negative value indicates an adjustment forward in time (later). A positive value indicates an adjustment back in time (earlier). The unit of measure is 100 ns (The NIU will adjust approximately its time offset to the closest value indicated by the Time_Offset_Value parameter, which implies that no extra clock is needed to adjust to the correct offset).

Power Control Setting

`Power_Control_Setting` is an 8-bit signed integer to be used to set the new power level of the NIU. (A positive value represents an increase of the output power level)

New `output_power_level` = current `output_power_level` + `power_control_setting` × 0,5 dB

Ranging Slot Number

`Ranging_Slot_Number` is a 16-bit unsigned integer that represents the reserved access Slot Number assigned for Ranging the NIU. It shall be assigned by the INA in the reservation area. The INA shall assure that an unassigned slot precedes and follows the ranging slot.

Only 13 lowest significant bits shall be considered. 3 MSB are reserved for future used.

Frequency Offset value

`Frequency_Offset_Value` is a 32-bit signed integer representing the upstream carrier offset frequency compared to the centre IF frequency. The unit of measure is in Hz.

5.5.4.4 <MAC> Ranging and Power Calibration Response Message (Upstream Ranging or reserved)

The <MAC> RANGING AND POWER CALIBRATION RESPONSE Message is sent by the NIU to the INA in response to the <MAC> RANGING AND POWER CALIBRATION MESSAGE. The format of the message is shown in the following table.

Table 26: Ranging and Power Calibration Response Message Structure

Ranging_Power_Response_Message (){	Bits	Bytes	Bit Number / Description
<code>Power_Control_Setting</code>	8	1	
}			

Power Control Setting

`Power_Control_Setting` is an 8-bit unsigned integer representing the actual power used by the NIU for upstream transmission. The unit of measure is 0,5 dBμV.

5.5.4.5 <MAC> Initialization Complete Message (Singlecast Downstream)

The <MAC> INITIALIZATION COMPLETE Message is sent by the INA to the NIU/STB to indicate the end of the HtmlResAnchor MAC Sign-On and Provisioning procedure. The STB/NIU shall re-enter the initialization process after receiving a non-zero `Completion_Status_Field` value. The <MAC> Transmission Control Message can be used to stop the NIU from sending upstream messages.

Table 26a

Initialization_Complete_Message (){	Bits	Bytes	Bit Number / Description
Completion_Status_Field		1	
Reserved	4		7..4
Invalid_STB/HtmlResAnchor NIU	1		3: {no, yes}
Timing_Ranging_Error	1		2: {no, yes}
Power_Ranging_Error	1		1: {no, yes}
Other_Error	1		0: {no, yes}
}			

Completion_Status_Field

Completion_Status_Field is an 8-bit field that indicates errors in the initialization phase. It has the following subfields:

Invalid_STB/HtmlResAnchor NIU is a Boolean that (when set to 1) indicates that the STB/NIU is invalid.

Timing_Ranging_Error is a Boolean that (when set to 1) indicates that the ranging has not succeeded.

Power_Ranging_Error is a Boolean that (when set to 1) indicates that the power ranging has not succeeded.

Other_Error is a Boolean that (when set to 1) indicates an error with unspecified type.

5.5.4.6 Frequency ranging

It can happen in LMDS systems that the NIU upstream frequency doesn't fit into the service channel demodulator frequency window, as the upstream frequency uncertainty is specified to be ± 200 kHz at the reference point B1, while the detection window of a burst demodulator is usually lower than 100 kHz.

In that case, the NIU will perform the normal ranging procedure described in Figure 30. When the NIU doesn't receive a Ranging and Power calibration message, it will change its upstream frequency with the procedure illustrated in the figure below: first D_f , then $-DF$, than $+2DF$, etc. DF being the frequency_ranging_step defined in the default_configuration_message.

In the example below, the NIU first tries at a frequency outside the demodulator window; at the third attempt, it falls within the window, and receives a Ranging and Power calibration Message with a frequency_offset parameter to shift the NIU frequency at the middle of the demodulator window.

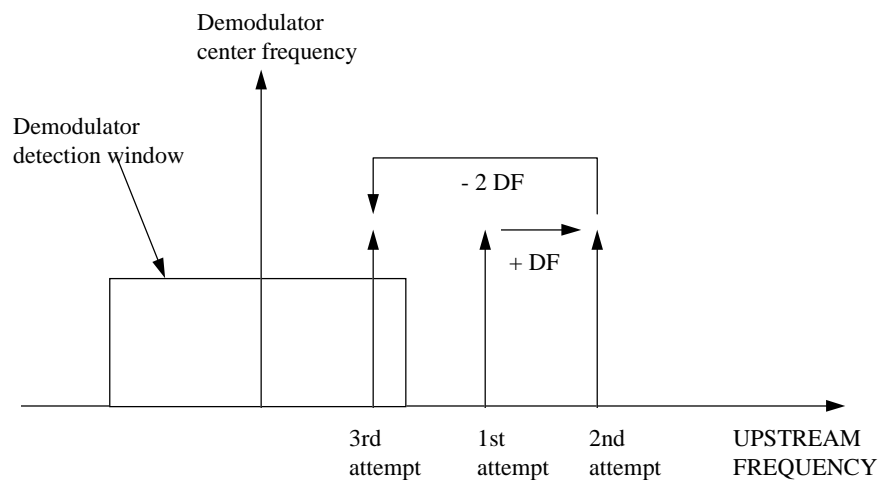

Figure 31a

5.5.5 Connection Establishment

Two cases shall be considered:

- 1) establishment of the first (initial) connection;
- 2) establishment of additional connections.

5.5.5.1 Establishment of the First (Initial) Connection

After Initialization, Provisioning and Sign On Procedures are complete, the INA shall assign an upstream and downstream connection to the NIU. This connection can be assigned on any of the upstream channels. The INA shall assign the connection by sending the **<MAC> Connect Message** to the NIU. This message shall contain the upstream connection parameters and downstream frequency on which the connection is to reside.

The NIU, upon receiving the **<MAC> Connect Message** shall tune to the required upstream and downstream frequencies and send the **<MAC> Connect Response Message** confirming receipt of the message. However, if the US and/or the DS frequency contained in the **<MAC> Connect Message** is different than the current US and/or DS frequency, the NIU/STB shall tune to the new frequency and enter the Sign-On procedure as defined in subclause 5.5.4, the Connection_Established flag being set and the NIU/STB retry count reset. The NIU/STB shall send the **<MAC> Connect Response Message** after the **<MAC> Initialization Complete Message**.

Upon receipt of the **<MAC> Connect Response Message**, the INA shall confirm the new connection by sending the **<MAC> Connect Confirm Message**.

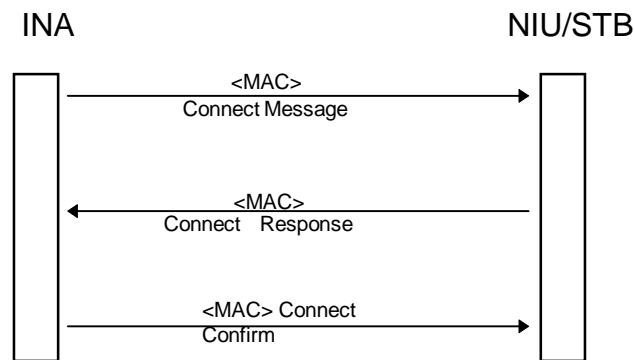

Figure 32: Connection Signalling for the Initial Connection

A more detailed description of the connection establishment process, including state diagrams and time outs, is given in Annex A.

<MAC> Connect Message (Singlecast Downstream)

Table 27: Connect Message Structure

Connect_Message (){	Bits	Bytes	Bit Number / Description
Connection_ID	32	4	
Session_Number	32	4	
Connection_Control_Field_Aux		1	
Reserved	6		7..2: shall be 0
Encapsulation_Included	1		1: {no, yes}
DS_Multiprotocol_CBD_Included	1		0: {no, yes}
Resource_Number	8	1	
Connection_Control_Field		1	
DS_ATM_CBD_Included	1		7: {no, yes}
DS_MPEG_CBD_Included	1		6: {no, yes}
US_ATM_CBD_Included	1		5: {no, yes}
Upstream_Channel_Number	3		4..2
Slot_List_Included	1		1: {no, yes}
Cyclic_Assignment	1		0: {no, yes}
Frame_Length	16	2	
Maximum_Contention_Access_Message_Length	8	1	
Maximum_Reservation_Access_Message_Length	8	1	
<i>if(Connection_Control_Field &= DS_ATM_CBD_Included)</i> {			
Downstream_ATM_CBD()	(64)	(8)	
}			
<i>if(Connection_Control_Field &= DS_MPEG_CBD_Included)</i> {			
Downstream_MPEG_CBD()	(48)	(6)	
}			
<i>if(Connection_Control_Field &= US_ATM_CBD_Included)</i> {			
Upstream_ATM_CBD()	(64)	(8)	
}			
<i>if(Connection_Control_Field &= Slot_List_Included)</i> {			
Number_Slots_Defined	(8)	(1)	
<i>for (i=0;i<Number_Slots_Defined; i++){</i>			
Slot_Number	(16)	(2)	
}			
}			
<i>if (MAC_Control_Params == Cyclic_Assignment){</i>			Fixed RateAccess
Fixedrate_Start	(16)	(2)	
Fixedrate_Dist	(16)	(2)	
Fixedrate_End	(16)	(2)	
}			
<i>if (Connection_Control_Field_Aux &= DS_Multiprotocol_CBD_Included)</i> {			
Downstream_Multiprotocol_CDB()	(48)	(6)	
}			
<i>if (Connection_Control_Field_Aux &= Encapsulation_Included)</i> {			
Encapsulation	(8)	(1)	
}			
}			

Connection ID

Connection_ID is a 32-bit unsigned integer representing a connection Identifier for the NIU Dynamic Connection.

Session Number

Session_Number is a 32-bit unsigned integer representing the Session that the connection parameters are associated. This parameter is not used by the present document specification.

Connection Control Field_Aux

Reserved is a 6-bit field, for future extensions. This field shall be zero.

Encapsulation_Included is a Boolean that indicates that the type of encapsulation is included in the message.

DS_Multiprotocol_CBD_Included is a Boolean that indicates that the Downstream Multiprotocol Descriptor is included in the message.

Resource Number

Resource_Number is a 8-bit unsigned integer providing a unique number to the resource defined in the message. This parameter is not used by the present document specification.

Connection Control Field

DS_ATM_CBD_Included is a Boolean that indicates that the Downstream ATM Descriptor is included in the message.

DS_MPEG_CBD_Included is a Boolean that indicates that the Downstream MPEG Descriptor is included in the message.

US_ATM_CBD_Included is a Boolean that indicates that the Upstream ATM Descriptor is included in the message.

Upstream_Channel_Number is a 3-bit unsigned integer which identifies the logical channel (denoted by "c") assigned to the NIU/STB. See subclause 5.3.2.1 for the use of this parameter.

Slot_List_Included is a Boolean that indicates that the Slot List is included in the message.

Cyclic_Assignment is a Boolean that indicates Cyclic Assignment.

The connection type can be deduced from the presence or the absence of the Connection Control Fields relative to the CBDs. The following table summarizes the valid combinations:

Table 27a

DS_ATM_CBD	DS_MPEG_CBD	Connection Type
YES	NO	OOB
NO	YES	DVB Multiprotocol Encapsulation over MPEG [3]
YES	YES	Reserved for ATM over DVB Data piping over MPEG [5]

All other combinations will not be used by the INA. If so, the message shall be ignored by the NIU/STB (no <MAC>Connect Response Message shall be sent).

Frame Length

Frame_length - This 16-bit unsigned number represents the number of successive slots in the fixed rate access region associated with each fixed rate slot assignment. In the slot_list method of allocating slots it represents the number of successive slots associated with each element in the list. In the cyclic method of allocating slots it represents the number of successive slots associated with the Fixedrate_Start_slot and those which are multiples of Fixedrate_Distance from the Fixedrate_Start_slot within the Fixed rate access region.

Maximum Contention Access Message Length

Maximum_contention_access_message_length is an 8-bit number representing the maximum length of a message in ATM sized cells that may be transmitted using contention access. Any message greater than this should use reservation access.

Maximum Reservation Access Message Length

Maximum_reservation_access_message_length is an 8-bit number representing the maximum length of a message in ATM sized cells that may be transmitted using a single reservation access. Any message greater than this shall be transmitted by making multiple reservation requests.

*Downstream ATM Connection Block Descriptor***Table 28: Downstream_ATM_CBD substructure**

Downstream_ATM_CBD (){	Bits	Bytes	Bit Number / Description
Downstream_Frequency	32	4	
Downstream_VPI	8	1	
Downstream_VCI	16	2	
Downstream_Type	8	1	
}			

Downstream_Frequency is a 32-bit unsigned integer representing the Frequency where the connection resides. The unit of measure is in Hz.

Downstream_VPI is an 8-bit unsigned integer representing the ATM Virtual Path Identifier that is used for downstream transmission over the Dynamic Connection.

Downstream_VCI is an 16-bit unsigned integer representing the ATM Virtual Channel Identifier that is used for downstream transmission over the Dynamic Connection.

Downstream_Type is an 8-bit enumerated type indicating the modulation format for the down stream connection. {QPSK IB, reserved, QPSK_3,088, 3...255 reserved}

*Downstream MPEG Connection Block Descriptor***Table 29: Downstream_MPEG_CBD substructure**

Downstream_MPEG_CBD (){	Bits	Bytes	Bit Number / Description
Downstream_Frequency	32	4	
Program_Number	16	2	
}			

Downstream_Frequency is a 32-bit unsigned integer representing the Frequency where the connection resides. The unit of measure is in Hz.

Program_Number is a 16-bit unsigned integer uniquely referencing the downstream virtual connection assignment (PID of the MPEG-2 program, **not** equal to the program number defined by MPEG-2!). Only the 13 least significant bits are valid, the three most significant bits are reserved for future use.

*Upstream ATM Connection Block Descriptor***Table 30: Upstream_ATM_CBD substructure**

Upstream_ATM_CBD (){	Bits	Bytes	Bit Number / Description
Upstream_Frequency	32	4	
Upstream_VPI	8	1	
Upstream_VCI	16	2	
MAC_Flag_Set	5	1	7..3
Upstream_Rate	3		2..0
}			

`Upstream_Frequency` is a 32-bit unsigned integer representing the channel on assigned to the connection. The unit of measure is in Hz.

`Upstream_VPI` is an 8-bit unsigned integer representing the ATM Virtual Path Identifier that is used for upstream transmission over the Dynamic Connection.

`Upstream_VCI` is an 16-bit unsigned integer representing the ATM Virtual Channel Identifier that is used for upstream transmission over the Dynamic Connection.

`MAC_Flag_Set` is a 5-bit field representing the first `HtmlResAnchor` MAC Flag set assigned to the logical channel. A downstream channel contains information for each of its associated upstream channel. This information is contained within structures known as MAC Flag Sets represented by either 24 bits (denoted `b0...b23`) or by 3 bytes (denoted `Rxa, Rxb, Rxc`). This information is uniquely assigned to a given upstream channel. See subclauses 5.3.1.3 and 5.3.2.1 for the use of this parameter.

`Upstream_Rate` is an 3-bit enumerated type indicating the upstream transmission bit rate for the upstream connection. {reserved, reserved, `Upstream_3,088 M`, `Upsteam_6,176 M`, 4...7 reserved}

Number of Slots Defined

`Number_Slots_Defined` is an 8-bit unsigned integer that represents the number of slot assignments contained in the message. The unit of measure is slots.

Slot Number

`Slot_Number` is a 16-bit unsigned integer that represents the Fixed rate based Slot Number assigned to the NIU. Only 13 lowest significant bits shall be considered. 3 MSB are reserved for future used.

Fixed Rate Start

`Fixedrate_Start` - This 16-bit unsigned number represents the starting slot within the fixed rate access region that is assigned to the NIU. The NIU may use the next `Frame_length` slots of the fixed rate access regions. Only 13 lowest significant bits shall be considered. 3 MSB are reserved for future used.

Fixed Rate Distance

`Fixedrate_Distance` - This 16-bit unsigned number represents the distance in slots between additional slots assigned to the NIU. The NIU is assigned all slots that are a multiple of `Fixedrate_Distance` from the `Fixedrate_Start_slot` which don't exceed `Fixedrate_End_slot` The NIU may use the next `Frame_length` slots of the fixed rate access regions from each of these additional slots.

Fixed Rate End

`Fixedrate_End` - This 16-bit unsigned number indicates the last slot that may be used for fixed rate access. The slots assigned to the NIU, as determined by using the `Fixedrate_Start_slot`, the `Fixedrate_Distance` and the `Frame_length`, cannot exceed this number. Only 13 lowest significant bits shall be considered. 3 MSB are reserved for future use.

Downstream Multiprotocol Connection Block Descriptor

Table 31: Downstream_Multiprotocol_CBD substructure

Downstream_Multiprotocol_CBD () {	Bits	Bytes	Bit Number / Description
MAC_Address	48	6	
}			

`MAC_Address` is a 48-bit MAC address, identifying an additional MAC address (used for example for multicast) to filter on in the DVB Multiprotocol Encapsulation header, according to EN 301 192 [3]. By default the NIU filters on its own MAC address and the Broadcast MAC address `FF:FF:FF:FF:FF:FF`.

`Encapsulation` is an 8-bit field that indicates the type of encapsulation provided: {`Direct_IP`, `Ethernet_MAC_Bridging`, `PPP`, reserved 3...7}.

<MAC> Connect Response (Upstream Contention or Reserved)

The <MAC> CONNECT RESPONSE MESSAGE is sent to the INA from the NIU in response to the <MAC> CONNECT MESSAGE. The message shall be transmitted on the upstream frequency specified in the <MAC> CONNECT MESSAGE. If the Upstream frequency is different than the current upstream frequency, then the procedure described in subclause 5.5.4 shall be used before the <MAC> Connect Response Message is sent. If the Connect Confirm message does not arrive within the specified time interval, the NIU shall re-send the Connect Response message.

Table 32: Connect response message structure

Connect_Response (){	Bits	Bytes	Bit Number / Description
Connection_ID	32	4	
}			

Connection ID

Connection_ID is a 32-bit unsigned integer representing a global connection Identifier for the NIU Dynamic Connection.

<MAC> Connect Confirm (Singlecast Downstream)

The <MAC> Connect Confirm message is sent from the INA to the NIU.

Table 33: Connect Confirm message structure

Connect_Confirm (){	Bits	Bytes	Bit Number / Description
Connection_ID	32	4	
}			

Connection ID

Connection_ID is a 32-bit unsigned integer representing a global connection Identifier for the NIU Dynamic Connection.

5.5.5.2 Establishment of Additional Connections

The INA can assign additional connections by using the <MAC> **Connect Message** described previously. The NIU can request such connections using the <MAC> **Resource Request Message**. Besides from that, the message sequence is the same as for the initial connection, with the following restrictions:

- The US frequency shall be the same for all connections, and the OOB and IB frequencies shall be the same for all OOB and IB connections respectively.
- If a <MAC>**Connect Message** is received with new values of US and/or DS frequency, the NIU/STB will ignore the message.
- If needed, the INA will use one of the resource management procedure to modify the US or DS frequency (see subclauses TDMA Allocation Management and Link Management) before sending the additional <MAC>**Connect Message**.

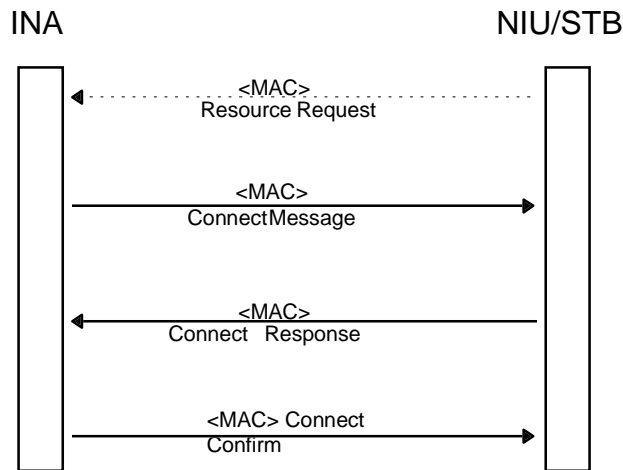

Figure 33: Connection signalling for additional connections

A more detailed description of the connection establishment process, including state diagrams and time outs, is given in Annex A.

<MAC> Resource Request Message (Upstream)

The NIU may request a new connection, may request to change the parameters of an existing connection and may request to release an existing connection by sending a <MAC> Resource Request Message to the INA. The INA can answer to that request by sending a <MAC> Connect Message, a <MAC> Reservation_ID Assignment Message / <MAC> Reprovision Message or a <MAC> Release Message, respectively, to the NIU or by sending a <MAC> Resource Request Denied Message to the NIU.

Table 34: Resource Request Message Structure

Resource_Request_Message (){	Bits	Bytes	Bit Number / Description
Resource_Request_ID	8	1	
Connection_ID	32	4	
Field		1	
Reserved	5		7..3: shall be zero
Release_Requested	1		2: {no, yes}
Reservation_ID_Requested	1		1: {no, yes}
Cyclic_Assignment_Needed	1		0: {no, yes}
Requested_Bandwidth	24	3	The unit is slots/1 200 ms
Maximum_Distance_Between_Slots	16	2	The unit is slots
Encapsulation	8	1	
}			

Resource_Request_ID is an 8-bit unsigned integer which identifies the resource request. The value of the **Resource_Request_ID** is incremented by one for every new resource request of the NIU.

Connection_ID is a 32-bit field which identifies the connection for which changes are requested. If the value of **Connection_ID** is zero, a new connection is requested.

Reserved: Reserved for future use. Shall be zero.

Release_Requested: If set to one, the release of the connection is requested. In this case, all following parameters of the message shall be ignored by the INA.

Reservation_ID_Requested: If set to one, a **Reservation_ID** is requested for the connection.

Cyclic_Assignment_Needed: If set to one, cyclic assignment is requested for fixed rate access for the connection. If **Requested_Bandwidth** is zero, this field is ignored by the INA.

Requested_Bandwidth: Gives the requested bandwidth for fixed rate access for the connection in slots/300 ms.

Maximum_Distance_Between_Slots: Gives the requested maximum distance between assigned fixed rate slots. If Requested_Bandwidth is zero, this field is ignored by the INA.

Encapsulation is an 8-bit field that indicates the type of encapsulation requested: {Direct_IP, Ethernet_MAC_Bridging, PPP, reserved 3...7}.

<MAC> Resource Request Denied Message (Singlecast Downstream)

The INA may respond to a resource request of the NIU with a <MAC> Resource Request Denied Message:

Table 35: Resource Request Denied Message Structure

Resource_Request_Denied_Message () {	Bits	Bytes	Bit Number / Description
Resource_Request_ID	8	1	
}			

Resource_Request_ID is an 8-bit unsigned integer which identifies the resource request which is denied.

5.5.6 Connection Release

This subclause defines the MAC signalling requirements for connection release. Figure 34 below displays the signalling flow for releasing a connection. The NIU can request the release of a connection using the <MAC> Resource Request Message.

- 1) The NIU may request the release of a connection using the <MAC> Resource Request Message, or the INA itself can initiate the release process.
- 2) Upon receiving the <MAC> Release Message from the INA, the NIU shall tear down the upstream connection established for the specified Connection_ID.
- 3) Upon teardown of the upstream connection, the NIU shall send the <MAC> Release Response Message on the upstream channel previously assigned for that connection. If the Connection_ID is unknown by the NIU, it shall send zero in the response message. If the Number_of_Connections in the Connection Release Message is zero, then the NIU shall release all open connections.

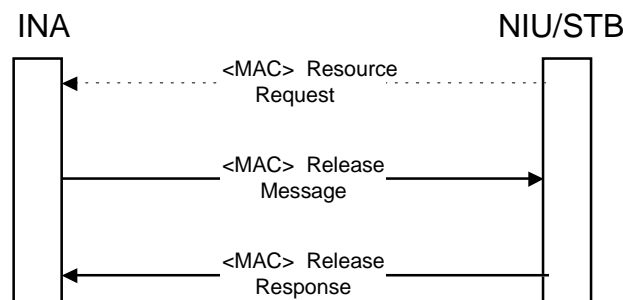

Figure 34: Connection release signalling

A more detailed description of the connection release process, including state diagrams and time outs, is given in Annex A.

<MAC> Release Message (Singlecast Downstream)

The <MAC> Release Message is sent from the INA to the NIU to terminate a previously established connection.

Table 36: Release Message Structure

Release_Message (){	Bits	Bytes	Bit Number / Description
Number_of_Connections	8	1	
<i>for(i=0;i<Number_of_Connections;i++){</i>			
Connection_ID	(32)	(4)	
<i>}</i>			
}			

Connection ID

Connection_ID is a 32-bit unsigned integer representing a global connection Identifier for the NIU Dynamic Connection.

<MAC> Release Response (Upstream contention or reserved)

The <MAC> RELEASE RESPONSE MESSAGE is sent by the NIU to the INA to acknowledge the release of a connection. The format of the message is shown in the following table.

Table 37: Release Response Message structure

Release_Response_Message (){	Bits	Bytes	Bit Number / Description
Connection_ID	32	4	
}			

Connection ID

Connection_ID is a 32-bit unsigned integer representing the global connection Identifier used by the NIU for this connection.

5.5.7 Fixed Rate Access

Fixed rate access is provided by the INA using the <MAC> Connect Message. The INA is also allowed to assign slots in fixed rate access to a connection in response to a <MAC> Reservation Request Message.

5.5.8 Contention Based Access

The NIU shall use contention based slots specified by the slot boundary definition fields (Rx) to transmit contention based messages (see subclause 5.3). The format of contention based MAC messages is described by the MAC message format (see subclause 5.5.2.3).

5.5.9 Reservation Access

This subclause defines the MAC signalling requirements for reservation access. Figure 35 below displays the signalling flow for reserving an access.

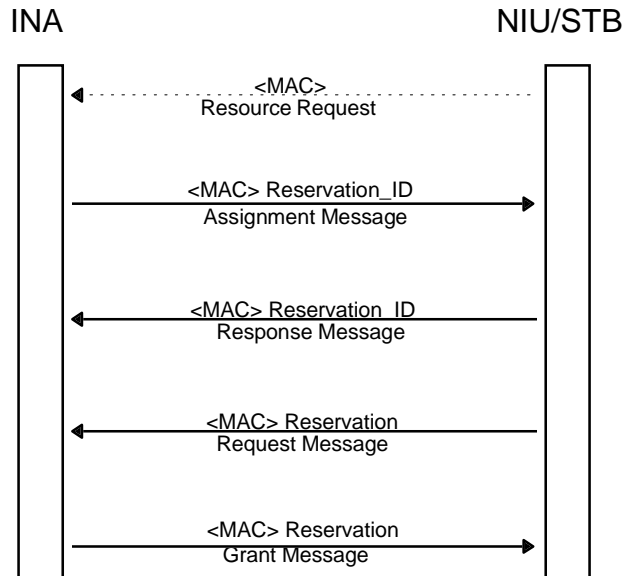

Figure 35: Reservation access signalling

- 1) The NIU can request a Reservation_ID using the <MAC> Resource Request Message.
- 2) The NIU shall wait for a <MAC> Reservation ID Assignment Message from the INA before it can request reservation access.
- 3) At any time when needed after receiving the reservation ID, the NIU can request a certain number of slots to the INA using the <MAC> Reservation Request Message.
- 4) The INA shall respond to that message using the <MAC> Reservation Grant Message.
- 5) If the NIU has not received the <MAC> Reservation Grant Message before the Grant_Protocol_Timeout, it shall send a <MAC> Reservation Status Request to the INA. This leads back to 3.

A more detailed description of the reservation process, including state diagrams and time outs, is given in Annex A.

<MAC> Reservation ID Assignment Message (Singlecast Downstream)

The <MAC> Reservation ID Assignment Message is used to assign the NIU a Reservation_ID. The NIU identifies its entry in the Reservation_grant_message by comparing the Reservation_ID assigned to it by the Reservation_ID_assignment_message and the entries in the Reservation_Grant_message.

The format of the message is given in the following table.

Table 38: Reservation ID assignment message structure

Reservation_ID_Assignment_Message () {	Bits	Bytes	Bit Number / Description
Connection_ID	32	4	
Reservation_ID	16	2	
Grant_protocol_timeout	16	2	
}			

Connection ID

`Connection_ID` is a 32-bit unsigned integer representing a global connection identifier for the NIU Dynamic Connection.

Reservation ID

`Reservation_ID` is a 16-bit unsigned number representing an identifier for the connection. This is used as a short identifier by the NIU to identify the appropriate `Reservation_Grant_Messages`.

Grant_protocol_timeout

`Grant_protocol_timeout` is a 16-bit unsigned number representing the time in milliseconds that the NIU should wait before verifying the status of pending grants. This parameter specifies the time that the NIU should wait after receiving the last <MAC> `Reservation_grant_message`, with an entry addressed to the NIU, before initiating a reservation status request. If the NIU has pending grants and the timeout occurs, it should send the `Reservation_status_request` message to the INA. The INA will respond with the `Reservation_grant_message` (probably without granting any slots) to inform the NIU of any remaining slots left to be granted. This allows the NIU to correct any problems should they exist such as issuing an additional request for slots or waiting patiently for additional grants.

<MAC> Reservation ID Response Message (Upstream contention or reserved)

The <MAC> Reservation ID Response Message is used to acknowledge the receipt of the <MAC> `Reservation_ID_Assignment` message.

The format of the message is given below.

Table 38a

Reservation_ID_Response_Message (){	Bits	Bytes	Bit Number / Description
Connection_ID	32	4	
Reservation_ID	16	2	
}			

Connection ID

`Connection_ID` is a 32-bit unsigned integer representing a global connection identifier for the NIU/STB Dynamic Connection.

Reservation ID

`Reservation_ID` is a 16-bit unsigned number representing an identifier for the connection. This is used as a short identifier by the NIU/STB to identify the appropriate `Reservation_Grant_Messages`.

<MAC> Reservation Request Message (Upstream contention or reserved)**Table 39: Reservation Request Message structure**

Reservation_Request_message (){	Bits	Bytes	Bit Number / Description
Reservation_ID	16	2	
Reservation_request_slot_count	8	1	
}			

This message is sent from the NIU to the INA.

Reservation ID

`Reservation_ID` is a 16-bit unsigned number representing an identifier for the connection. This is used as a short identifier by the NIU to identify the appropriate `Reservation_Grant_Messages`.

Reservation Request Slot Count

Reservation_request_slot_count is an 8-bit unsigned number representing the number of slots requested by the NIU. This is the number of sequential slots that will be allocated in the reservation region of the upstream channel. The INA will respond with the Reservation_Grant message granting the request.

<MAC> Reservation Grant Message (Broadcast Downstream)

The <MAC> RESERVATION GRANT MESSAGE is used to indicate to the NIU which slots have been allocated in response to the Reservation Request message. The NIU identifies its entry in the Reservation_grant_message by comparing the Reservation_ID assigned to it by the Reservation_ID_assignment_message and the entries in the Reservation_Grant_message.

The format of the message is given in the following table.

Table 40: Reservation Grant Message structure

Reservation_grant_message (){	Bits	Bytes	Bit Number / Description
Reference_slot	16	2	
Number_grants	8	1	
<i>for (l=0; l<Number_grants; l++){</i>			
Reservation_ID	(16)	(2)	
Grant_Slot_count	(4)	(2)	15..12
Remaining_slot_count	(5)		11..7
Grant_slot_offset	(7)		6..0
}			
Number_of_US_Channels	8	1	
<i>for(l=0; l<Number_of_US_Channels;l++){</i>			
Minislot_Control_Field		(1)	
Upstream_Channel_Number	(3)		7..5
MS_Feedback_Included	(1)		4: {no, yes}
MS_Allocation_Included	(1)		3: {no, yes}
Reserved	(3)		2..0
<i>if (MS_Feedback_Included MS_Allocation_Included) {</i>			
MS_Reference_Field	(16)	(2)	
}			
<i>if (MS_Feedback_Included) {</i>			
Number_of_Feedbacks	(8)	(1)	
<i>for(l=0;l<Number_of_Feedbacks; l++){</i>			
Feedback_Offset	(8)	(1)	
Feedback_Collision_Number_1	(8)	(1)	
Feedback_Collision_Number_2	(8)	(1)	
Feedback_Collision_Number_3	(8)	(1)	
}			
}			
<i>if (MS_Allocation_Included) {</i>			
Entry_Field		(2)	
Stack_Entry	(1)		15
Reserved	(3)		14..12
Entry_Spreading	(12)		11..0
Number_of_Allocations	(8)	(1)	
<i>for(l=0;l<Number_of_Allocations; l++){</i>			
Allocation_Offset	(8)	(1)	
Allocation_Collision_Number	(8)	(1)	
}			
}			
}			
}			

Reference_slot

Reference_slot is an 16-bit unsigned number indicating the reference point for the remaining parameters of this message. This represents a physical slot of the upstream channel. Since the upstream and downstream slots are not aligned, the INA shall send this message in a downstream slot such that it is received by the NIU before the *Reference_slot* exists on the upstream channel. Only 13 lowest significant bits shall be considered. 3 MSB are reserved for future use.

Number_grants

Number_grants is an 8-bit unsigned number representing the number of grants contained within this message. This can either correspond to grants for different NIUs, or to different connection_IDs for the same NIU.

Reservation_ID

Reservation_ID is a 16-bit unsigned number representing an identifier for the connection. This is used as a short identifier by the NIU to identify the appropriate *Reservation_Grant_Messages*.

Grant_slot_count

Grant_slot_count is a 4-bit unsigned number representing the number of sequential slots currently granted for the upstream burst. A value of zero indicates that no slots are being granted. This would typically be the case in a response to a *Reservation_status_request* message.

Upon receipt of this message the NIU is assigned *Grant_slot_count* sequential slots in the region of the upstream channel starting at the position indicated by the *Reference_slot* and *Grant_slot_offset* values (jumps are needed in the case where the number of slots granted exceeds the length of this region).

Remaining_slot_count

Remaining_slot_count is a 5-bit unsigned number representing the remaining slots to be granted by the INA with subsequent grant messages. A value of 0x1f indicates that 31 or more slots will be made available in the future. A value of 0x0 indicates that no additional slots will be granted in the future and that the slots granted in this message represent the only remaining slots available for the connection. The NIU should monitor this count to determine if sufficient slots remain to satisfy current needs. Should additional slots be required because of lost grant messages or additional demand, additional slots should be requested using the *Reservation_request_message*. Additional *Reservation_request_messages* shall be sent only when the *Remaining_slot_count* is less than 15. To minimize contention on the upstream channel, the *Reservation_request_message* may be sent in one of the slots granted by the *Reservation_grant_message*. The remaining slot count is calculated for each grant in a *Reservation Grant* message.

Grant_slot_offset

Grant_slot_offset is a 7-bit unsigned number representing the starting slot to be used for the upstream burst. This number is added to the *Reference_slot* to determine the actual physical slot.

Number_of_US_Channels

Number_of_Channels is a 8-bit unsigned integer representing the number of Upstream channels in this message.

Minislot_Control_Field

Upstream_Channel_Number is a 3-bit unsigned integer representing the upstream channel concerned by this iteration.

MS_Feedback_Included is a Boolean that indicates that *Minislot Feedback Section* is included in the message.

MS_Allocation_Included is a Boolean that indicates that *Minislot Allocation Section* is included in the message.

Minislot_Reference_Field

Minislot_Reference_Field is a 16-bit field of which the 13 LSBs represent the reference ATM slot number.

Number_of_Feedbacks

Number_of_Feedbacks is a 8-bit unsigned integer representing the number of three *minislot feedback groups* in this message.

Feedback_Offset

Feedback_Offset is a 8-bit unsigned integer representing the offset of the group of three minislots in ATM slots. This number is added to the *Minislot_Reference_Field* to determine the actual physical slot.

Feedback_Collision_Number_1

Feedback_Collision_Number_1 is a 8-bit unsigned integer representing the first minislot collision identification in the group of three minislots. The values 0xFF and 0xFE represent for idle and successful transmission, respectively. Other values are called *Collision_Number* and are used to resolve contentions (see *Allocation_Collision_Number* field).

Feedback_Collision_Number_2

Feedback_Collision_Number_2 is a 8-bit unsigned integer representing the second minislot collision identification in the group of three minislots. The values 0xFF and 0xFE represent for idle and successful transmission, respectively. Other values are called *Collision_Number* and are used to resolve contentions (see *Allocation_Collision_Number* field).

Feedback_Collision_Number_3

Feedback_Collision_Number_3 is a 8-bit unsigned integer representing the third minislot collision identification in the group of three minislots. The values 0xFF and 0xFE represent for idle and successful transmission, respectively. Other values are called *Collision_Number* and are used to resolve contentions (see *Allocation_Collision_Number* field).

Entry_Field

Stack_Entry is a Boolean parameter. When it is set to 0, collision resolution is according to the tree algorithm (see subclause 5.6.3) and NIUs with new requests have to wait for mini-slots with the *Allocation_Collision_Number* equal to 0 to enter the request contention process. When *Stack_Entry* is set to one, NIUs with new requests can enter the request contention process in any minislot (independent of the value of *Allocation_Collision_Number*). After entering in this way to the contention process, the collision resolution is identical to the tree mode. So, the difference between *Stack_Entry* set to 0 or 1 is that in the latter case NIUs don't have to wait for minislots with *Allocation_Collision_Number* equal to 0 before they can start sending a new request in contention mode.

Entry_Spreading is a 14-bit unsigned integer that is used to control the number of NIUs that enter the request contention process in minislots with the corresponding *Allocation_Collision_Number* equal to 0. The NIU generates a random number between 0 and *Entry_Spreading* (the random number generator in the NIU shall have a uniform distribution). If this number falls within the window from 0 to the number of slots with *Allocation_Collision_Number* equal to 0, then the NIU contends for access in the corresponding minislot, otherwise it will not transmit a request but wait for the next set of minislots with *Allocation_Collision_Number* equal to 0 and follow the same procedure again.

Number_of_Allocations

Number_of_Allocations is a 8-bit unsigned integer representing the number of contention resolution allocations in this message.

Allocation_Offset

Allocation_Offset is a 8-bit unsigned integer representing the offset of the group of three minislots in ATM slots to be added to the *Minislot_Reference_Field* to determine the physical slot number of the group of three minislots.

Allocation_Collision_Number

Allocation_Collision_Number is a 8-bit unsigned integer associated with the group of three minislots. Only NIUs having their *Collision_Number* equal to *Allocation_Collision_Number* are allowed to transmit in these minislots.

<MAC> Reservation Status Request (Upstream contention or reserved)

The <MAC> RESERVATION STATUS REQUEST Message is used to determine the status of the outstanding grants to be assigned by the INA. This message is only sent after the Grant protocol time-out is exceeded. The INA will respond with the *Reservation_grant_message* (possibly without granting any slots) to inform the NIU of any remaining slots left to be granted. This allows the NIU to correct any problems should they exist such as issuing an additional request for slots or waiting patiently for additional grants.

The format of the message is given in the following table.

Table 41: Reservation status request message structure

Reservation_Status_Request_Message (){	Bits	Bytes	Bit Number / Description
Reservation_ID	16	2	
Remaining_request_slot_count	8	1	
}			

Reservation_ID

Reservation_ID is a 16-bit unsigned number representing an identifier for the connection. This is used as a short identifier by the NIU to identify the appropriate Reservation_Grant_Messages.

Remaining_request_slot_count

Remaining_request_slot_count is an 8-bit unsigned number representing the number of slots that the NIU is expecting to be granted.

5.5.10 MAC Link Management

The MAC Link Management tasks provide continuous monitoring and optimization of upstream resources. These functions include:

- Power and Timing Management;
- Fixed rate Allocation Management;
- Channel Error Management.

5.5.10.1 Power and Timing Management

Power and Timing Management shall provide continuous monitoring of upstream transmission from the NIU. The <MAC> **Ranging and Power Calibration Message** is used to maintain a NIU within predefined thresholds of power and time.

The Upstream Burst Demodulator shall continuously monitor the upstream burst transmissions from an NIU. Upon detection of an NIU outside the predefined range, the INA shall send the <MAC> **Ranging and Power Calibration Message** to the NIU.

The NIU/STB upstream power accuracy shall be better than or equal to $\pm 1,5$ dB. The NIU/STB power resolution shall be 0,5 dB nominally.

A detailed description of the re-calibration process, including state diagrams and time outs, is given in Annex A.

5.5.10.2 TDMA Allocation Management

To ensure optimum assignment of TDMA resources, the INA shall ensure the upstream allocation of TDMA resources for various connections remain intact when allocating resources to a new connection. However, in the event that reconfiguration is required to minimize fragmentation of resources, then the INA shall dynamically reconfigure the upstream TDMA assignments to a NIU or group of NIUs. The <MAC> **Reprovision Message** is utilized to change previously established connection parameters.

The NIU can request the change of some parameters of existing connections by use of the <MAC> **Resource Request Message**, in which case the <MAC> **Reprovision Message** can be used by the INA to confirm the requested changes.

A detailed description of the reprovisioning process, including state diagrams and time outs, is given in Annex A.

<MAC> **Reprovision Message (Singlecast Downstream)**

The <MAC> REPROVISION MESSAGE is sent by the INA to the NIU to reassign upstream resources (maintaining the originally requested QoS parameters at the establishment of the connection.) This message is intended for Fixed rate based channel maintenance by the INA to redistribute or reassign resources allocated to a NIU.

Table 42: Reprovision Message structure

Reprovision_Message (){	Bits	Bytes	Bit Number / Description
Reprovision_Control_Field		1	
Reserved	1		7
Delete_Reservation_IDs	1		6: {no, yes}
New_Downstream_IB_Frequency	1		5: {no, yes}
New_Downstream_OOB_Frequency	1		4: {no, yes}
New_Upstream_Frequency_Included	1		3: {no, yes}
New_Frame_Length_Included	1		2: {no, yes}
New_Cyclical_Assignment_Included	1		1: {no, yes}
New_Slot_List_Included	1		0: {no, yes}
<i>if (Reprovision_Control_Field &=</i> <i>New_Downstream_IB_Frequency) {</i>			
New_Downstream_IB_Frequency	(32)	(4)	
<i>}</i>			
<i>if (Reprovision_Control_Field &=</i> <i>New_Downstream_OOB_Frequency) {</i>			
New_Downstream_OOB_Frequency	(32)	(4)	
DownStream_Type	(8)	(1)	
<i>}</i>			
<i>if (Reprovision_Control_Field &=</i> <i>New_Frequency_Included) {</i>			
New_Upstream_Frequency	(32)	(4)	
New Upstream Parameters		(2)	
New_Upstream_Channel Number	(3)		15..13
Reserved	(2)		12..11
Upstream_Rate	(3)		10..8: enum
MAC_Flag_Set	(5)		7..3
Reserved	(3)		2..0
<i>}</i>			
<i>if (Reprovision_Control_Field &=</i> <i>New_Frame_Length_Included){</i>			
New_Frame_Length	(16)	(2)	9-0: Unsigned
<i>}</i>			
<i>if (Reprovision_Control_Field &=</i> <i>New_Slot_List_Included </i> <i>New_Cyclical_Assignment_Included </i> <i>Delete_Reservation_IDs){</i>			
Number_of_Connections	(8)	(1)	
<i>for(i=0;i<Number_of_Connections;i++){</i>			
Connection_ID	(32)	(1)	
<i>if(Reprovision_Control_Field &=</i> <i>new_slot_list_included){</i>			Fixed Rate Access
Number_Slots_Defined	(8)	(1)	
<i>for(i=0;i<Number_Slots_Assigned;i++){</i>			
Slot_Number	(16)	(2)	
<i>}</i>			
<i>}</i>			
<i>if (Reprovision_Control_Field &=</i> <i>new_cyclic_Assignment_included){</i>			Fixed Rate Access
Fixedrate_Start	(16)	(2)	
Fixedrate_Dist	(16)	(2)	
Fixedrate_End	(16)	(2)	
<i>}</i>			
<i>}</i>			
<i>}</i>			

Reprovision Control Field

`Reprovision_Control_Field` specifies what modifications to upstream resources are included. It consists of the following subfields:

`Delete_Reservation_IDs` is a Boolean that indicates that the NIU/STB shall delete all `Reservation_IDs` that have been assigned to the `Connection_IDs` contained in this message.

`New_Downstream_IB_Frequency` is a Boolean that indicates that a new downstream IB frequency is specified in the message

`New_Downstream_OOB_Frequency` is a Boolean that indicates that a new downstream OOB frequency is specified in the message

`New_Upstream_Frequency_Included` is a Boolean that indicates that a new upstream frequency is specified in the message.

`New_Frame_Length_Included` is a Boolean that indicates that a new upstream frame is specified in the message. In the Reprovision Message the `Frame_Length` is a global value which applies to all `connection_ID` referred in this message.

`New_Cyclical_Assignment_Included` is a Boolean that indicates that a new cyclical assignment is specified in the message.

`New_Slot_List_Included` is a Boolean that indicates that a new slot list is specified in the message.

New Downstream IB Frequency

`New_Downstream_IB_Frequency` is a 32-bit unsigned integer representing the reassigned downstream IB carrier centre frequency. The unit of measure is Hz.

New Downstream OOB Frequency

`New_Downstream_OOB_Frequency` is a 32-bit unsigned integer representing the reassigned downstream OOB carrier centre frequency. The unit of measure is Hz.

DownStream Type

`DownStream_Type` is an 8-bit enumerated type indicating the modulation format for the down stream connection. {reserved, reserved, QPSK_3,088, 3...255 reserved}

New Upstream Frequency

`New_Upstream_Frequency` is a 32-bit unsigned integer representing the reassigned upstream carrier centre frequency. The unit of measure is Hz.

New Upstream Parameters

`New_Upstream_Channel_Number` is a 3-bit unsigned integer which identifies the new logical channel (denoted by "c") assigned to the NIU/STB. See subclause 5.3.2.1 for the use of this parameter.

`Upstream_Rate` is an 3-bit enumerated type indicating the upstream transmission bit rate for the upstream connection. {reserved, reserved, Upstream_3,088 M, Upstream_6,176 M, 4...7 reserved}

`MAC_Flag_Set` is a 5-bit field representing the first MAC Flag set assigned to the new logical channel. A downstream channel contains information for each of its associated upstream channel. This information is contained within structures known as MAC Flag Sets represented by either 24 bits (denoted b0...b23) or by 3 bytes (denoted Rxa, Rxb, Rxc). This information is uniquely assigned to a given upstream channel. See subclauses 5.3.1.3 and 5.3.2.1 for the use of this parameter.

New Frame Length

`New_Frame_Length` is a 16-bit unsigned integer representing the size of the reassigned upstream Fixed rate based frame. The unit of measure is in slots.

Number of Slots Defined

Number_Slots_Defined is an 8-bit unsigned integer that represents the number of slot assignments contained in the message. The unit of measure is slots.

Slot Number

Slot_Number is a 16-bit unsigned integer that represents the Fixed rate based Slot Number assigned to the Network Interface Unit. Only 13 lowest significant bits shall be considered. 3 MSB are reserved for future used.

Fixed rate Start

Fixedrate_Start - This 16-bit unsigned number represents the starting slot within the fixed rate access region that is assigned to the NIU. The NIU may use the next Frame_length slots of the fixed rate access regions. Only 13 lowest significant bits shall be considered. 3 MSB are reserved for future used.

Fixed rate Distance

Fixedrate_Distance - This 16-bit unsigned number represents the distance in slots between additional slots assigned to the NIU. The NIU is assigned all slots that are a multiple of Fixedrate_Distance from the Fixedrate_Start_slot which don't exceed Fixedrate_End_slot. The NIU may use the next Frame_length slots of the fixed rate access regions from each of these additional slots.

Fixed rate End

Fixedrate_End - This 16-bit unsigned number indicates the last slot that may be used for fixed rate access. The slots assigned to the NIU, as determined by using the Fixedrate_Start_slot, the Fixedrate_Distance and the Frame_length, cannot exceed this number. Only 13 lowest significant bits shall be considered. 3 MSB are reserved for future use.

5.5.10.3 Channel Error Management

During periods of connection inactivity (no upstream <MAC> transmission by an NIU), the NIU shall enter an Idle Mode. Idle mode is characterized by periodic transmission by the NIU of a <MAC> **Idle Message**. The Idle Mode transmission shall occur at a periodic rate sufficient for the INA to establish Packet Error Rate statistics. The Idle Message shall be sent only when the NIU/STB has at least one connection, after the <MAC> Connect Confirm Message is received.

A detailed description of idle message transmission, including state diagrams and time outs, is given in Annex A.

<MAC> Idle Message (Upstream contention or reserved)

The <MAC> **Idle Message** is sent by the NIU within the STB to the INA at predefined intervals (between 1 and 10 minutes) when the NIU is in idle mode.

Table 43: Idle Message structure

Idle_Message (){	Bits	Bytes	Bit Number / Description
Idle_Sequence_Count	8	1	
Power_Control_Setting	8	1	
}			

Idle Sequence Count

Idle_Sequence_Count is a 8-bit unsigned integer representing the count (modulo 256) of <MAC> IDLE MESSAGES transmitted while the NIU is Idle. It counts the number of transmitted Idle Messages since the last sign-on, thus it starts counting at 0.

Power Control Setting

Power_Control_Setting is an 8-bit unsigned integer representing the actual power used by the NIU/STB for upstream transmission. The unit of measure is 0,5 dB μ V.

5.5.10.4 Link Management Messages

<MAC> Transmission Control Message (Singlecast or Broadcast Downstream)

The <MAC> TRANSMISSION CONTROL MESSAGE is sent to the NIU from the INA to control several aspects of the upstream transmission. This includes stopping upstream transmission, re-enabling transmission from a NIU or group of NIU's and rapidly changing the upstream frequency being used by a NIU or group of NIU's. To identify a group of NIU's for switching frequencies, the <MAC> TRANSMISSION CONTROL MESSAGE is sent in broadcast mode with the `Old_Downstream_Frequency` included in the message. When broadcast with the `Old_Downstream_Frequency`, the NIU shall compare its current frequency value to `Old_Downstream_Frequency`. When equal, the NIU shall switch to the new frequency specified in the message. When unequal, the NIU shall ignore the new frequency and remain on its current channel.

A detailed description of the transmission control process, including state diagrams and time outs, is given in Annex A.

Table 44: Transmission Control Message structure

Transmission_Control_Message (){	Bits	Bytes	Bit Number / Description
Transmission_Control_Field		1	
Reserved	1		7
Change_Timeouts	1		6: {no, yes}
Switch_Downstream_IB_Frequency	1		5: {no, yes}
Stop_Upstream_Transmission	1		4: {no, yes}
Start_Upstream_Transmission	1		3: {no, yes}
Old_Frequency_Included	1		2: {no, yes}
Switch_Downstream_OOB_Frequency	1		1: {no, yes}
Switch_Upstream_Frequency	1		0: {no, yes}
<i>if (Transmission_Control_Field &= Switch_Upstream_Frequency && Old_Frequency_Included){</i>			
Old_Upstream_Frequency	(32)	(4)	
<i>}</i>			
<i>if (Transmission_Control_Field &= Switch_Upstream_Frequency){</i>			
New_Upstream_Frequency	(32)	(4)	
New_Upstream_Channel_Number	(3)	(1)	7..5
Reserved	(2)		4..3
Upstream_Rate	(3)		2..0
MAC_Flag_Set	(5)	(1)	7..3
Reserved	(3)		2..0
<i>}</i>			
<i>if (Transmission_Control_Field &= Switch_Downstream_OOB_Frequency && Old_Frequency_Included){</i>			
Old_Downstream_OOB_Frequency	(32)	(4)	
<i>}</i>			
<i>if (Transmission_Control_Field &= Switch_Downstream_OOB_Frequency){</i>			
New_Downstream_OOB_Frequency	(32)	(4)	
Downstream_Type	(8)	(1)	
<i>}</i>			
<i>if (Transmission_Control_Field &= Switch_Downstream_IB_Frequency && Old_Frequency_Included){</i>			
Old_Downstream_IB_Frequency	(32)	(4)	
<i>}</i>			
<i>if (Transmission_Control_Field &= Switch_Downstream_IB_Frequency){</i>			
New_Downstream_IB_Frequency	(32)	(4)	
<i>}</i>			
<i>if (Transmission_Control_Field &= Change_Timeouts){</i>			
Number_of_Timeouts	(8)	(1)	
<i>for (I=0; I<Number_of_Timeouts;I++) {</i>			
Field		(1)	
Code	(4)		
Value	(4)		
<i>}</i>			
<i>}</i>			
<i>}</i>			

Transmission Control Field

`Transmission_Control_Field` specifies the control being asserted on the upstream channel:

`Change_Timeouts` is a Boolean when set indicates that timeout codes and values are included in the message.

`Switch_Downstream_IB_Frequency` is a Boolean when set indicates that a new downstream IB frequency is included in the message.

`Stop_Upstream_Transmission` is a Boolean when set indicates that the NIU should halt its upstream transmission. The NIU shall respond to the ranging and power calibration message regardless of the setting of the `start_upstream_transmission` bit.

`Start_Upstream_Transmission` is a Boolean when set indicates that the Network Interface Unit should resume transmission on its upstream channel.

`Old_Frequency_Included` is a Boolean when set indicates that the Old Frequency value is included in the message and should be used to determine if a switch in frequency is necessary

`Switch_Downstream_OOB_Frequency` is a Boolean when set indicates that a new downstream OOB frequency is included in the message.

`Switch_Upstream_Frequency` is a Boolean when set indicates that a new upstream frequency is included in the message. Typically, the `switch_upstream_frequency` and the `stop_upstream_transmission` are set simultaneously to allow the NIU to stop transmission and change channel. This would be followed by the <MAC> TRANSMISSION CONTROL MESSAGE with the `start_upstream_transmission` bit set.

Old Upstream Frequency

`Old_Upstream_Frequency` is a 32-bit unsigned integer representing the frequency that should be used by the NIU to compare with its current frequency to determine if a change in channel is required.

New Upstream Frequency

`New_Upstream_Frequency` is a 32-bit unsigned integer representing the reassigned upstream carrier centre frequency. The unit of measure is Hz.

`New_Upstream_Channel_Number` is a 3-bit unsigned integer which identifies the new logical channel (denoted by "c") assigned to the NIU/STB. See subclause 5.3.2.1 for the use of this parameter.

`Upstream_Rate` is an 3-bit enumerated byte indicating the upstream transmission bit rate for the upstream connection. {reserved, reserved, Upstream_3,088 M, 3...7 reserved}

`MAC_Flag_Set` is a 5-bit field representing the first MAC Flag set assigned to the logical channel. A downstream channel contains information for each of its associated upstream channel. This information is contained within structures known as MAC Flag Sets represented by either 24 bits (denoted b0...b23) or by 3 bytes (denoted Rxa, Rxb, Rxc). This information is uniquely assigned to a given upstream channel. See subclauses 5.3.1.3 and 5.3.2.1 for the use of this parameter.

Old Downstream OOB Frequency

`Old_Downstream_OOB_Frequency` is a 32-bit unsigned integer representing the frequency that should be used by the NIU to compare with its current frequency to determine if a change in channel is required.

New Downstream OOB Frequency

`New_Downstream_OOB_Frequency` is a 32-bit unsigned integer representing the reassigned downstream OOB carrier centre frequency. The unit of measure is Hz.

`DownStream_Type` is an 8-bit enumerated type indicating the modulation format for the down stream connection. {reserved, reserved, QPSK_3,088, 3...255 reserved}

Old Downstream IB Frequency

`Old_Downstream_IB_Frequency` is a 32-bit unsigned integer representing the frequency that should be used by the NIU to compare with its current frequency to determine if a change in channel is required.

New Downstream IB Frequency

`New_Downstream_IB_Frequency` is a 32-bit unsigned integer representing the reassigned downstream IB carrier centre frequency. The unit of measure is Hz.

Number_of_Timeouts

`Number_of_Timeouts` is a 8-bit unsigned integer which identifies the number of timeout codes and values included in the message.

Code

`Code` is a 8-bit unsigned integer which identifies the timeout or group of timeouts (according to Table 21, and Table 51) for which the following value is given.

Value

`Value` is a 8-bit unsigned integer which gives the value for the timeout or group of timeouts identified by the preceding code. The unit of measure is 100 ms. The value shall be between the Min Value and the Max Value given in Table 21, and Table 51 (if specified). If no values are given in the <MAC> Default Configuration Message, the default values apply. Values for single timeouts overwrite values for groups of timeouts for the specified timeout.

<MAC> Link Management Response Message (Upstream contention or reserved)

The <MAC> LINK MANAGEMENT RESPONSE MESSAGE is sent by the NIU to the INA to indicate reception and processing of the previously sent Link Management Message. The format of the message is shown in the following table.

Table 45: Link Management Acknowledge Message structure

Link_Management_Acknowledge () {	Bits	Bytes	Bit Number /Description
Link_Management_Msg_Number	16	2	
}			

Link Management Message Number

`Link_Management_Msg_Number` is a 16-bit unsigned integer representing the previously received link management message. The valid values for `Link_Management_Msg_Number` are shown in the following table.

Table 46: Link Management Message Number

Message Name	Link_Management_Msg_Number
Transmission Control Message	Transmission Control Message Type Value
Reprovision Message	Reprovision Message Type Value

<MAC> Status Request Message (Downstream Singlecast)

The STATUS REQUEST message is sent by the INA to the NIU to retrieve information about the NIU's health, connection information and error states. The INA can request either the address parameters, error information, connection parameters or physical layer parameters from the NIU. The INA can only request one parameter type at a time to a particular NIU.

A detailed description of the status request process, including state diagrams and time outs, is given in Annex A.

Table 47: Status Request Message structure

Status_Request () {	Bits	Bytes	Bit Number / Description
Status_Control_Field		1	
<i>Reserved</i>	4		4...7
Status_Type	4		0..3: {enum type}
}			

Status Control Field

Status_Control_Field is a 3-bit enumerated type that indicates the status information the NIU should return

```
enum Status_Control_Field {Address_Params, Error_Params, Connection_Params,  
Physical_Layer_Params, reserved 4...7};
```

<MAC> Status Response Message (Upstream contention or reserved)

The <MAC> STATUS RESPONSE MESSAGE is sent by the NIU in response to the <MAC> STATUS REQUEST MESSAGE issued by the INA. The contents of the information provided in this message will vary depending on the request made by the INA and the state of the NIU. The message shall be dissociated into separate messages if the resulting length of the message exceeds 40 bytes, even if fragmentation of <MAC> messages is supported.

Table 48: Status Response Message Structure

Status_Response (){	Bits	Bytes	Bit Number / Description
NIU_Status		4	
Reserved	29		31..3
Network_Address_Registered	1		2
Connection_Established	1		1
Calibration_Operation_Complete	1		0
Response_Fields_Included		1	
Reserved	4		4..7:
Address_Params_Included	1		3: {no, yes}
Error_Information_Included	1		2: {no, yes}
Connection_Params_Included	1		1: {no, yes}
Physical_Layer_Params_Included	1		0: {no, yes}
<i>if (Response_Fields_Included &= Address_Params_Included){</i>			
NSAP_Address	(160)	(20)	
MAC_Address	(48)	(6)	
<i>}</i>			
<i>if (Response_Fields_Included &= Error_Information_Included){</i>			
Number_Error_Codes_Included	(8)	(1)	
<i>for(i=0;i<Number_Error_Codes_Included; i++){</i>			
Error_Param_code	(8)	(1)	
Error_Param_Value	(16)	(2)	
<i>}</i>			
<i>}</i>			
<i>if (Response_Fields_Included &= Connection_Params_Included) {</i>			
Number_of_Connections	(8)	(1)	
<i>for(i=0;i<Number_of_Connections;i++){</i>			
Connection_ID	(32)	(4)	
<i>}</i>			
<i>}</i>			
<i>if (Response_Fields_Included &= Physical_Layer_Params_Included) {</i>			
Power_Control_Setting	(8)	(1)	
Reserved	(16)	(2)	
Time_Offset_Value	(16)	(2)	
Upstream_Frequency	(32)	(4)	
OOB_Downstream_Frequency	(32)	(4)	
IB_Downstream_Frequency	(32)	(4)	
SNR_Estimated	(8)	(1)	
Power_Level_Estimated	(8)	(1)	
<i>}</i>			
<i>}</i>			

NIU Status

NIU_Status is a 32-bit unsigned integer that indicates the current state of the NIU.

Table 48a

NIU_Status	NIU Status Code
Calibration_Operation_Complete	0x01
Connection_Established	0x02
Network_Address_Registered (reserved)	0x04

The state `Calibration_Operation_Complete` is reached after an Initialization Complete Message with status zero. The `Connection_Established` state indicates that the NIU has received a Connect Message indicating a connection which has not been released yet.

Response Fields Included

`Response_Fields_Included` is an 8-bit unsigned integer that indicates what parameters are contained in the upstream status response.

NSAP Address

`NSAP_Address` is a 20 byte address assigned to the NIU.

MAC Address

`MAC_Address` is a 6 byte address assigned to the NIU.

Number of Error Codes Included

`Number_Error_Codes_Included` is an 8-bit unsigned integer that indicates the number of error codes are contained in the response.

Error Parameter Code

`Error_Parameter_Code` is a 8-bit unsigned integers representing the type of error reported by the NIU.

`Error_Parameter_Codes` not supported by the NIU are not send.

Table 49: Error Parameter Code

Error Parameter Code Name	Error Parameter Code
Reserved for compatibility	0x00
Slot_Configuration_CRC_Error_Count	0x01
Reed_Solomon_Error_Count	0x02
ATM_Packet_Loss_Count	0x03
Slot_Configuration_Count	0x04
SL-ESF_CRC_Error_Count	0x05
Reed_Solomon_Errors_Correctable	0x06
Reed_Solomon_Errors_Non_Correctable	0x07
SL-ESF_Frame_Count	0x08

- `Slot_Configuration_CRC_Error_Count` refers to the number of errors in `Slot_Configuration_Count` R bytes, as found by the CRC decoder.
- `Reed_Solomon_Error_Count` refers the number of errors as corrected by the Reed_Solomon decoder.
- `ATM_Packet_Loss_Count` refers to the number of received ATM cells that were lost, either due to unrecoverable Reed-Solomon errors or because of an erroneous HEC of the ATM cells header.
- `SL-ESF_CRC_Error_Count` refers to the number of CRC errors found in consecutive C1-C6.
- `SL-ESF_Frame_Count` refers to the number of frames the statistics in this message apply on.
- `Slot_Configuration_Count` refers to the number of R-byte sets (Rxa-Rxc) used to calculate `Slot_Configuration_CRC_Error_Count`. This parameter is included so that NIUs can either measure only the errors in the R-byte set it is allocated to, or measure the errors in all R-byte sets.
- `Reed_Solomon_Errors_Correctable` refers to MPEG frames received with correctable Reed Solomon Errors (IB only).
- `Reed_Solomon_Errors_Non_Correctable` refers to MPEG frames received with non correctable Reed Solomon Errors (IB only).

Error Parameter Value

`Error_Parameter_Value` is a 16-bit unsigned integer representing error counts detected by the NIU. These values are set to 0 after they are transmitted to the INA. If the counter reaches its maximum value, it stops counting. The counter resumes counting after it is set to 0.

Number of Connections

`Number_of_Connections` is an 8-bit unsigned integer that indicates the number of connections that are specified in the response. Specifically, if the number of connections is too large to have a MAC message with less than 40 bytes, it is possible to send separate messages with only the number of connections indicated in each message.

ConnectionID

`Connection_ID` is a 32-bit unsigned integer representing the global connection Identifier used by the NIU for this connection.

Power Control Setting

`Power_Control_Setting` is an 8-bit unsigned integer representing the actual power used by the NIU/STB for upstream transmission. The unit of measure is 0,5 dB μ V.

Time Offset Value

`Time_Offset_Value` is a 16-bit short integer representing a relative offset of the upstream transmission timing. A negative value indicates an adjustment forward in time. A positive value indicates an adjustment back in time. The unit of measure is 100 ns.

Upstream Frequency

`Upstream_Frequency` is a 32-bit unsigned integer representing the channel assigned to the connections. The unit of measure is in Hz.

Downstream Frequencies

`OOB_Downstream_Frequency` is a 32-bit unsigned integer representing the Frequency where the connections on Out Of Band channel resides. The unit of measure is in Hz. When not significant field, this field is set to 0.

`IB_Downstream_Frequency` is a 32-bit unsigned integer representing the Frequency where the connections on In Band channel resides. The unit of measure is in Hz. When not significant field, this field is set to 0.

`SNR_Estimated` is an 8-bit unsigned integer specifying the NIU estimated signal to noise ratio of the downstream carrying MAC messages. The unit is dB*2. If the NIU is not able to estimate the value, the value zero (0) is used.

`Power_Level_Estimated` is an 8-bit unsigned integer specifying the NIU estimated power level of the downstream carrying MAC messages. The unit is dB μ V*2. If the NIU is not able to estimate the value, the value zero (0) is used.

5.6 Minislots

5.6.1 Carrying Minislots

Minislots may only be used to send <MAC> `Reservation_Request` messages. Only contention access is allowed for minislots.

Minislots can be utilized in both in-band signalled and out-of-band signalled systems. The in-band signalling uses the same control fields as the out-of-band signalling inside the MAC flags, and the MAC messages are the same for both in-band and out-of-band signalling case. The phrase minislot refers to a physical frame structure of the upstream channel. The 64 byte upstream slots are called ATM slots.

5.6.2 Minislot framing structure

In case minislots are used, the upstream slot structure is sub-divided into three 21 byte long mini-slots. Each of these minislots can be sent by different user terminals. The upstream channel can support a mixture of ATM slots and minislots. The format of the minislot is shown in the following figure. It contains a 4 byte Unique Word (the minislot UW and the ATM slot UW will differ to enable simple decoding of the ATM slots and the minislots by the PHY), a single byte Start field, a 16 byte payload and a single byte guard band.

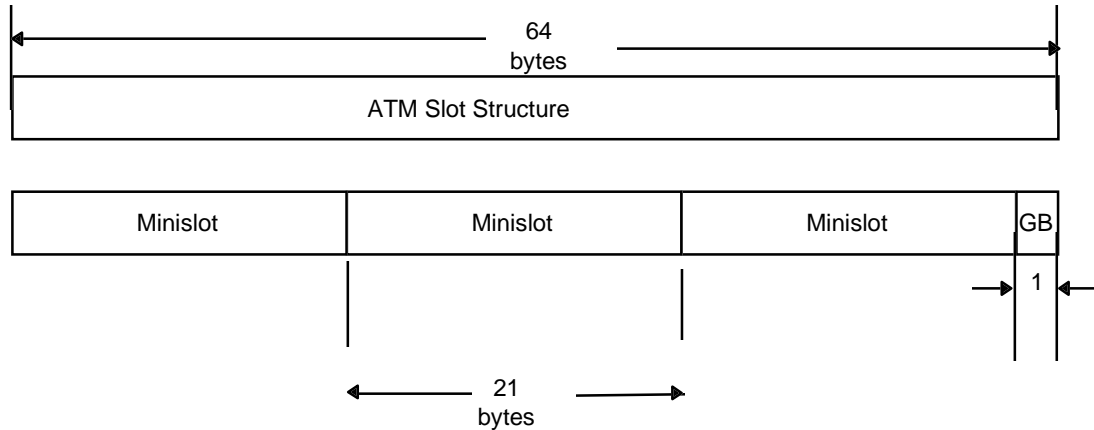

Figure 36: Minislot Framing Structure

For the structure of the minislot itself see subclause 5.5.2.6.

5.6.3 Contention resolution for minislots

Minislots may carry the Reservation Request MAC message. The message is sent in a contention based minislot. In the case of collision, the resolution is carried out according to a INA controlled ternary splitting algorithm (see Figure 37). All necessary information is transmitted in the minislot feedback and minislot allocation sections of the Reservation_Grant_Message.

If Stack_Entry is not set a NIU may enter the contention process only when the Allocation_Collision_Number is equal to zero. the number of minislots with Allocation_Collision_Number equal to 0.

If Stack_Entry is set, the NIU may enter the contention resolution in any of the contention based minislots, independent of the value of Allocation_Collision_Number.

Furthermore both cases the random number for the minislot selection in the range between 0 and Entry_Spreading shall be in the window from 0 to 2 before sending the request.

If Stack_Entry is set, the NIU may enter the contention resolution in any of the contention based minislots, independent of the value of the Feedback_Collision_Number equals to 0xFF and 0xFE for idle and successful transmission, respectively. All other values of the Collision_Number are numbered as collisions and used to select the retransmission minislots: the NIU shall retransmit in a minislot having an Allocation_Collision_Number equal to Collision_Number

The retransmission of the collided request takes place in a minislot that is randomly selected among a the group of three minislots with the corresponding Allocation_Collision_Number.

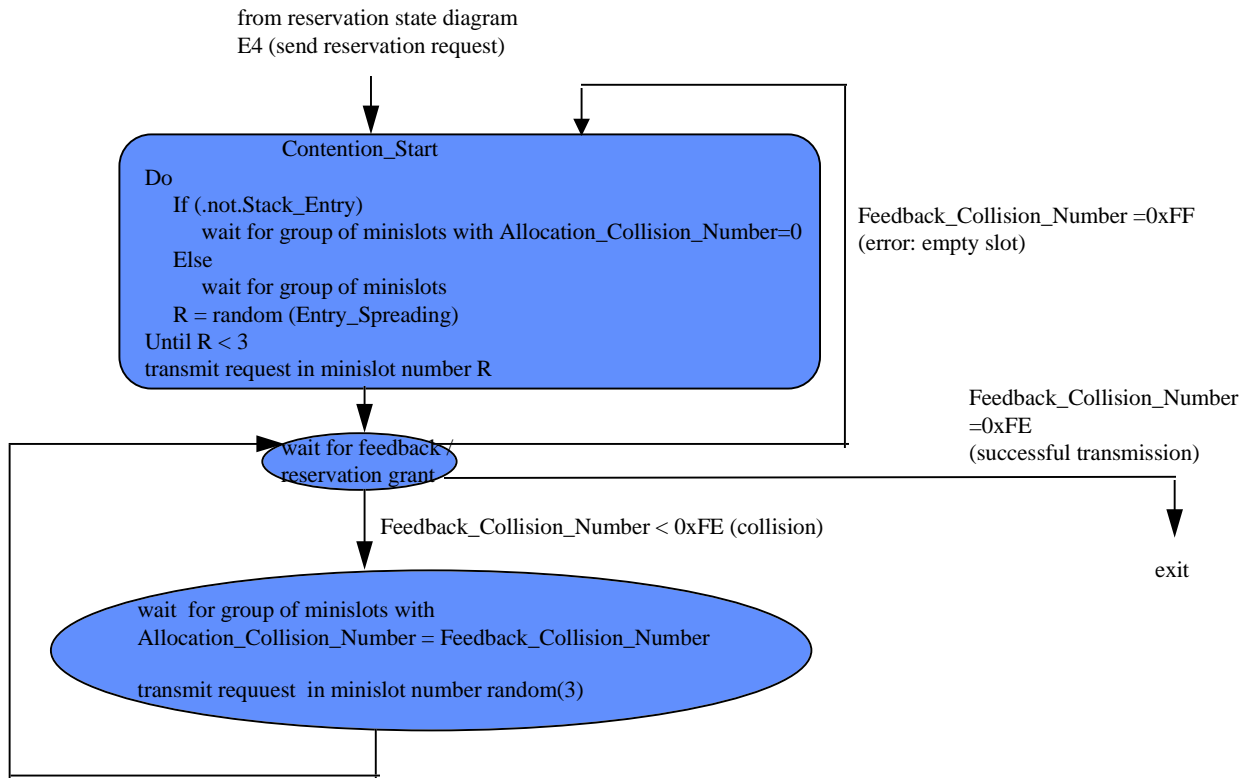

Figure 37: Ternary Splitting Algorithm

5.7 Security (optional)

The security solution consists of two separate sub-systems:

- A new set of MAC messages used for authentication and key-agreement between INA and NIU. These messages are used only during connection-set-up.
- On-the-fly encryption and decryption of payload data streams passed between INA and NIU.

When a connection is being set-up, before payload data is transferred, one of three new request/response MAC message-pairs is used to generate a session key specific to the payload stream associated with the connection.

The session key is a shared secret between the INA and the NIU: even if every MAC message is intercepted, the cryptographic properties of the protocol ensure that an eavesdropper cannot determine the session key value.

This is achieved by using a public-key protocol, which requires no up-front shared secret, or a simpler protocol based on a long-term shared secret between INA and NIU called a cookie. The cookie is 160 bits long. It is also used for authenticating the NIU to the INA during connection-set-up.

Each NIU will store its own cookie in non-volatile storage, whereas the INA will maintain a data-base of the cookie values of the NIUs on its network. Cookie values will be updated occasionally as dictated by security policy, but they are less vulnerable than session keys: a successful brute-force attack on a session key reveals nothing about the cookie value, nor any other session key.

The new MAC messages also implement a defence against clones: a NIUs that is a physical copy of an existing NIU and attempts to operate on the network under the cloned identity (when the cloned NIU itself is not registered on the network). The anti-cloning measure is a simple non-volatile 8-bit counter that is incremented synchronously at the INA and NIU over time: if a clone NIU engages in traffic with the INA, this will be detected the next time the cloned NIU connects because the counter value will be out of synchronization.

If the clone attempts to operate concurrently with the cloned unit, there will be an immediate break-down of functionality for both units, due to confusion within the MAC protocol. This amounts to a denial-of-service attack, and the INA should be prepared for this kind of protocol failure.

5.7.1 Cryptographic primitives

The key exchange protocols and data stream encryption is based on a set of well-established primitive cryptographic functions. The functions and their associated key sizes can be changed in the future, in case crypt-analytic or brute-force attacks become a realistic threat.

The specific set of functions and key sizes are negotiated between INA and NIU at sign-on time. The functions supported at the present time are Diffie-Hellman, HMAC-SHA1, and DES. Check current cryptographic literature for any updates regarding their security and use.

The following sections give a brief overview of the cryptographic primitives, and details on how they are used in the protocol. Later sections describe the exact field layout of the new MAC messages.

The protocol parameters are described in terms of byte strings, where concatenation is denoted by the \sim operator. Integer quantities are represented as base-256 byte strings. Big-endian byte-ordering is used, that is, the most significant byte comes first. If necessary to reach a fixed length, the string is padded with zeros at the most significant end.

5.7.1.1 Public key exchange

A public key exchange primitive is used to allow the INA and NIU to agree on a secret, although communicating in public. The Diffie-Hellman scheme is based on unsigned integer arithmetic and works as follows (\wedge denotes exponentiation):

The INA chooses two public values, a large prime number m , and a (small) number g which is a generator modulo m (that is, $g^a \bmod m$ will generate all number from 0 to $m-1$ for varying a). The INA also chooses a secret number $x < m$, and sends the following three values to the NIU: $m, g, X = g^x \bmod m$.

The NIU chooses a secret value $y < m$, and responds to the INA with the value $Y = g^y \bmod m$.

The NIU now calculates $s = X^y \bmod m = (g^x)^y \bmod m = g^{(x*y)} \bmod m$, whereas the INA calculates $Y^x \bmod m = (g^y)^x \bmod m = g^{(y*x)} = s$, so the INA and NIU now agree on the value s .

The value of s is a secret shared between INA and NIU. To determine its value from the publicly communicated values m, g, X , and Y , an eavesdropper shall determine x or y by solving an equation of the form $Z = g^z \bmod m$ for unknown z . This is known as the discreet logarithm problem and is computationally infeasible with current algorithms for sufficiently large values of m .

The parameter size supported are 512 bits for the prime number m , and hence also for the remaining values since all arithmetic is modulo m .

In the applicable MAC messages, the unsigned integer quantities m, g, X , and Y are encoded into fixed-size fields (64, 96, or 128 bytes) using big-endian byte-ordering.

5.7.1.2 Hashing

The protocol makes use of a keyed hash function that computes secure checksums which can only be verified with the possession of a secret key. The function has the one-way property, meaning that it is computationally infeasible to find an input value that maps to a given output value.

The hash function is also used to generate derived secret material based on a master secret. Because of the one-way property, the master secret is protected even if the derived secret is discovered.

In generic terms, the keyed hash function takes two byte strings as input, the *key* and a *data* string, and produces another string of bytes, the *digest*:

$$\text{digest} = H(\text{key}, \text{data})$$

The H function shall accept key and data parameters of any size, whereas the protocol is designed to accept digests of any size.

The specification currently supports the HMAC-SHA1 function defined in IETF RFC 2104 [11]. It produces a 20-byte digest.

5.7.1.3 Encryption

Payload data is encrypted and decrypted using a symmetric-key block cipher, which is used in Cipher Block Chaining (CBC) mode with special handling of any final odd-size block.

In generic terms, the encryption and decryption functions take two byte strings as input, the key and a data block, and produce as output another data block of the same length:

$$ciphertext = E (key, plaintext)$$

$$D (key, ciphertext) = plaintext$$

The key length and block length is given by the chosen cipher, and the payload stream processing logic will apply it as appropriate to data units of various sizes.

The specification currently supports the DES algorithm, which has a block size is 8 bytes, and various options for key length based on an 8-byte raw key block (see subclause 5.7.5).

5.7.1.4 Pseudo-random numbers

The protocols used for generating secret values depend on the availability of a pseudo-random, that is, practically unpredictable, endless string of bytes. This will typically be produced with a Pseudo-Random Number Generator, PRNG, algorithm.

The random bytes are used to generate the secret Diffie-Hellman values, x and y , and for nonce values used during key exchange. The unpredictable nature of the random input ensures that different secret values are produced each time, and also prevents replay of old intercepted messages.

This specification does not require any particular algorithm, only that the INA and NIU each choose one that is well-established and cryptographically analysed.

The hardest aspect of using a PRNG is to initialize it with an unpredictable seed value. The seed should contain multiple high-granularity device-dependent time-samples, as well as any other available pseudo-random material, like file allocation tables, etc. These random source values are then hashed together to squeeze out the entropy for the seed value.

5.7.2 Main Key Exchange, MKE

Main Key Exchange uses Diffie-Hellman to develop a shared secret between the INA and NIU, which is independent of the cookie value. Furthermore, it uses the cookie value to authenticate the NIU to the INA. It optionally uses the newly developed shared secret to update the cookie value. Finally, it derives a shared secret key used for the security context that is used to process payload stream data.

The exchange is initiated by the INA sending a message containing the Diffie-Hellman values, m , g , X , and a random nonce string, *nonce1*. The NIU responds with a message containing its Diffie-Hellman value, Y , a random nonce string, *nonce2*, and an authentication string, *auth*.

The INA and NIU each use the same formula to calculate the authentication string:

$$auth = H (cookie, nonce1 \sim nonce2)$$

which is communicated by the NIU and checked by the INA. This proves the identity of the NIU, since it requires knowledge of the cookie to calculate the correct value of *auth*.

The NIU and INA each use the Diffie-Hellman values (see 5.7.1.1) to arrive at the same secret value, s :

$$s = g^{(x*y)} \text{ mod } m.$$

This unsigned integer value is encoded as a byte string, of length specified by the Diffie-Hellman parameter size, using big-endian byte ordering. It is then used to calculate a temporary shared secret string, *temp*:

$$temp = H (encode (s), nonce2 \sim nonce1).$$

If the cookie is to be updated, the new value is computed in sections for $n = 1, 2, \dots$:

$$\text{newcookie}(n) = H (\text{temp} \sim \text{byte}(1) \sim \text{byte}(n), \text{null}(\text{unsigned char})1 \sim (\text{unsigned char})n, \text{void})$$

where $\text{byte}(\dots)$ is a single-byte string with the specified value, and $\text{null}(\text{unsigned char})$ is the cast operator of the C programming language, and void is the empty string. These string values are computed and concatenated until the total length matches or exceeds the length of the cookie. The cookie is then obtained by taking the required number of bytes out of the concatenated sections, starting from the beginning.

The session key used for payload stream encryption is likewise computed in sections:

$$\text{key}(n) = H (\text{temp} \sim \text{byte}(2) \sim \text{byte}(n), \text{null})$$

where, again, a sufficient number of sections are calculated to produce enough bytes to cover the length of the key. The session key is obtained by taking the required number of bytes out of the concatenated sections, starting from the beginning.

5.7.3 Quick Key Exchange, QKE

Quick Key Exchange uses the existing cookie value to authenticate the NIU to the INA, and then derive a shared secret key used for the security context that is used to process payload stream data.

The exchange is initiated by the INA sending a message containing a random nonce string, nonce1 . The NIU responds with a message containing a random nonce string, nonce2 , and an authentication value, auth .

The value of auth is calculated in the same way as for Main Key Exchange, and is likewise used to verify the identity of the NIU (see subclause 5.7.2).

The NIU and INA then each calculate a temporary shared secret string, temp :

$$\text{temp} = H (\text{cookie} \sim \text{byte}(3), \text{nonce2} \sim \text{nonce1}).$$

This value is used to produce the payload encryption key in the same way as for Main Key Exchange (see subclause 5.7.2).

5.7.4 Explicit Key Exchange, EKE

Explicit Key Exchange is used by the INA to deliver a pre-determined session key to the NIU. The session key is encrypted under a temporary key derived from the cookie value, and is used for the security context that is used to process payload stream data.

The delivery is performed by the INA sending a message containing a random nonce string, nonce1 , and a byte string value, encryptedkey , which has the same length as a key used for payload encryption. The NIU responds with a message containing a random nonce string, nonce2 , and an authentication value, auth .

The value of auth is calculated in the same way as for Main Key Exchange, and is likewise used to verify the identity of the NIU (see subclause 5.7.2).

Both the INA and NIU calculate a temporary shared secret string, temp :

$$\text{temp} = H (\text{cookie} \sim \text{byte}(4), \text{nonce1})$$

which is used to produce sections of a temporary key, in the same way as for Main Key Exchange (see subclause 5.7.2). The INA uses these temporary key string sections to XOR with the session key to obtain the encryptedkey value, and the NIU performs a second XOR operation to decrypt the session key value.

For normal DES, 8 bytes of raw key data are delivered, which are used to derive the actual key with the appropriate number of effective bits, as described below (see subclause 5.7.5).

5.7.5 Key derivation

The actual key value used for processing payload data is derived from the *key* sections developed during key exchange. For DES, 8 bytes of raw key data is required, so a single 20-byte section, *key(1)*, computed by HMAC-SHA1 is sufficient.

In each byte, the least significant bit is not used (it can be used as an odd-parity bit of the remaining 7 bits), bringing the effective key size down to 56 bits.

Furthermore, when used in 40-bit mode, the two most significant bits of each byte in the key are zeroed.

5.7.6 Data stream processing

Security can be applied to various payload data streams selectively. The elementary unit is called a security context, which contains two session keys used for encrypting and decrypting a stream of payload data. Only one of the keys is used to process any particular payload unit. Each key can be used for processing both upstream and downstream payload data.

Having two keys allows negotiation of a new key to take place while payload data is processed using the old one, and then do an immediate switch-over once the new key is agreed upon, without interrupting payload traffic. The INA initiates the key exchanges, and can start using a session key for downstream traffic encryption once the key exchange is complete. For upstream traffic encryption, the NIU should use whichever key was used by the INA in the most recent payload unit.

5.7.6.1 Payload streams

A payload stream is identified by either of:

- a 24-bit (UNI) ATM virtual circuit VPI/VCI: this is used for ATM-based IB downstream, OOB downstream, and upstream payload data. The ATM circuit can be one-to-one, or one end-point of a multi-cast circuit;
- a 48-bit MAC-address: this is used for DVB Multiprotocol Encapsulation downstream payload data. The MAC-address can be the physical address of the STB or a pseudo address used for MAC-address based multi-casting.

When a payload stream is secured, the NIU and the INA will have matching security contexts, which are used to encrypt/decrypt both upstream and downstream traffic. For unsecured payload streams there is no security context, and payload data is not encrypted.

To support encrypted multi-cast traffic, the same security context will be created for each member using EKE (see subclause 5.7.4), so that each NIU can decrypt the common payload data stream.

5.7.6.2 Data encryption

Within a payload data stream, data is carried in individual units at the various protocol layers. Encryption is applied at the lowest layer possible, consistent with the payload stream:

- ATM-based payload streams: the unit of encryption is a single ATM cell. The 48-byte cell payload is encrypted using the security context implied by the 24-bit VPI/VCI of the cell header.

Encryption is transparent to higher-level protocol layers, which see only unencrypted cell payloads.

DVB Multiprotocol Encapsulation payload streams: the unit of encryption is a single DVB Multiprotocol Encapsulation section. The *datagram_data_bytes* (between the MAC-address and the CRC/checksum) are encrypted using the security context implied by the 48-bit MAC address in the section header. The DVB Multiprotocol Encapsulation payload to be encrypted will be adjusted to have a length of $n * 8$ bytes (n is an integer) by adding an appropriate amount (0...7 bytes) of stuffing bytes before the CRC/checksum according to [3]. The CRC/checksum is calculated on the encrypted datagram bytes, while higher-level protocol layers see only unencrypted datagrams.

5.7.6.3 Encryption flags

There are flags in the header of each encryption unit specifying which of the two sessions keys of the security context is used.

The receiver will use the security context of the payload stream to see if decryption shall be done.

- ATM cells: one bit of the Generic Flow Control, GFC, field of the cell header are used:
 - xxx0: encrypted using session key 0
 - xxx1: encrypted using session key 1
- DVB Multiprotocol Encapsulation sections, according to EN 301 192 [3]: the 2-bit payload_scrambling_control field in the section header is used:
 - 00: not encrypted
 - 01: reserved
 - 10: encrypted using session key 0
 - 11: encrypted using session key 1

The 2-bit address_scrambling_control field in the section header is 00 all the time (the address is not scrambled).

5.7.6.4 Chaining and initialization vector

Within encryption units, the block encryption algorithm is used in Cipher Block Chaining mode, CBC: the first plain-text block is XOR'ed with an initialization vector (IV), and subsequent blocks are XOR'ed with the previous cipher-text block, before the block is encrypted. Decryption is opposite: each cipher-text block is first decrypted and then XOR'ed with the previous chaining value.

If the last block is smaller than the size of an encryption block, the chaining value is encrypted directly (without being XOR'ed with the plain-text), and the result is XOR'ed with the plain-text, as many bytes as required. Decryption is identical (that is, the last chaining value is *encrypted*, whereas previous blocks are *decrypted*).

The value of the IV for a given encryption unit is zero.

5.7.7 Security Establishment

Security issues are handled in the following situations:

- When a NIU registers on the network it will do an initial handshake with the INA to establish the level of security support, in particular the cryptographic algorithms and key sizes to be used subsequently.

The handshake consists of <MAC>**Security Sign-On** and <MAC>**Security Sign-On Response** messages (see subclauses 5.7.9.1 and 5.7.9.2) which are exchanged immediately prior to the <MAC>**Initialization Complete** message.

A failure during this stage of the protocol causes the INA to revert to non-secure interaction with the NIU.

- The security context of a secured payload stream is established when the underlying MAC connection is created, before any stream data is transmitted. One session key is agreed, and the cookie and/or clone counter values may be updated as part of the exchange.

The key exchange consists of <MAC>**Main/Quick/Explicit Key Exchange** and <MAC>**Main/Quick/Explicit Key Exchange Response** messages (see subclauses 5.7.9.3 to 5.7.9.8) which are exchanged immediately prior to the <MAC>**Connect Confirm** message.

A failure during this stage of the protocol causes the connection-set-up operation to fail.

- After a connection is in use, each session key of the security context of the payload stream can be updated on-the-fly, that is, without re-establishing the underlying connection, and without interrupting payload data traffic. The cookie and/or clone counter values cannot be updated as part of the exchange.

A new session key is negotiated using the same MAC messages used during connection-set-up. There is no **<MAC>Connect Confirm** message.

A failure during this stage of the protocol causes the connection to be dropped.

While a session key of the security context is being updated for a particular connection, payload stream data traffic should be encrypted using the other session key or not at all. Once the key exchange is complete, the INA can start using it for subsequent downstream traffic, thereby directing the NIU to use it for upstream traffic.

All three variants of key exchange messages authenticate the NIU based on the existing cookie value. They also perform the clone detection counter check, and optionally increment the clone counter. Only MKE can update the cookie.

The security MAC message flow is naturally serialized within the context of the particular connection that is being set-up. But, in as far as multiple connections are being established concurrently, there can also be multiple concurrent key exchanges whose messages are interleaved. The NIU is free to complete outstanding key exchanges on separate connections in any order it chooses

5.7.8 Persistent state variables

To facilitate authentication, key exchange, and clone detection, the NIU has a set of state variables whose values are retained across registrations and power cycles:

Table 50: Persistent NIU variables

Name	Function	Size
Cookie	authentication cookie	160 bits
Cookie_SN	cookie sequence number	1 bit
Clone_Counter	clone detection counter	8 bits
Clone_Counter_SN	clone counter sequence number	1 bit

The sequence numbers are used to ensure that the INA and NIU can stay synchronized even in case the NIU drops off the net in the middle of a protocol exchange.

5.7.8.1 Guaranteed delivery

Within the set-up protocol for a MAC connection, the INA will ensure that a protocol exchange is complete before proceeding. If it doesn't receive a response MAC message within a given time-interval, it will re-transmit the original message unchanged. The NIU will do likewise in situations where it requires a response. If the number of re-transmissions exceeds three, the protocol fails.

Due to race conditions, superfluous re-transmissions may be generated by both INA and NIU. They shall discard such messages after the first message has in fact been received.

If the NIU is not ready to respond within the specified time-out, it can send **<MAC>Wait** messages (see subclause 5.7.9.9) to extend the time it has available to generate a proper response. Upon receiving the wait message, the INA will restart its timer and reset the retry count.

The protocol time-out values can be set by the **<MAC> Default Configuration Message**, otherwise the following default values apply:

Table 51: Protocol time-out values

Code	Protocol stage	Default Value
0xD	Security Sign-On	90
0xE	Main Key Exchange	600
0xF	Quick Key Exchange Explicit Key Exchange	300

Time-out values are:

Table 52: Protocol time-out values

Protocol stage	timeout value	
Security Sign-On	100 ms	
Main Key Exchange	400 ms	
Quick Key Exchange	200 ms	
Explicit Key Exchange	200 ms	

The Unit for the timeouts is ms.

5.7.9 Security MAC Messages

5.7.9.1 <MAC>Security Sign-On (Single-cast Downstream)

As part of the registration process when a NIU attaches to the network, the INA and NIU will negotiate the specific set of cryptographic algorithms and parameters used in the key exchange protocols and for payload encryption.

The selections are global, and apply to all subsequent security exchanges for as long as the NIU is registered on the network.

The selections affect the layout of the subsequent key exchange messages, since they have fields that vary in size according to the choice of algorithms and parameters.

The INA indicates which algorithms and parameters it supports by setting the appropriate bits in the <MAC>Security Sign-On message. There are four classes of algorithms, and the INA will set one or more bits in each of the four fields to indicate which specific choices it supports:

Table 53: Security Sign-On message structure

Security_Sign-On () {	Bits	Bytes	Bit Number / Description	Parameter bytes
Public_Key_Alg		1	Public key algorithm choices:	P_{pka}
PKA_Reserved	7		7..1: Reserved, shall be 0	64
PKA_DH_512	1		0: (yes/no) Diffie-Hellman, 512 bits	
Hash_Alg		1	Hash algorithm choices:	P_{ha}
HA_Reserved	7		7..1: Reserved, shall be 0	20
HA_HMACSHA1	1		0: (yes/no) HMAC-SHA1	
Encryption_Alg		1	Encryption algorithm choices:	P_{ea}
EA_Reserved	6		7..2: Reserved, shall be 0	8
EA_DES_56	1		1: (yes/no) DES, 56-bit key	
EA_DES_40	1		0: (yes/no) DES, 40-bit key	
				8
Nonce_Size		1	Nonce size choices:	P_{ns}
NS_Reserved NS_64	7		7..1: Reserved, shall be 0	8
	1		0: (yes/no) 8 random bytes	
Reserved	32	4	Reserved for future use, shall be 0	
}				

If the security option is supported, the minimum subset to support is PKA_DH_512, HA_HMACSHA1, EA_DES_40, and NS_64.

EA_DES_56 is optional.

5.7.9.2 <MAC>Security Sign-On Response (Upstream)

In its security sign-on response, the NIU indicates which specific algorithms and parameters to use. It does so by choosing one of the suggestions offered by the INA within each of the four classes.

The fields of the response message have the same definition as the message from the INA, except that exactly one bit will be set in each field.

If the NIU is unable to support any of the suggested algorithms for any class, it shall return an all-zero field value, and the INA will revert to non-secure communication or re-issue the <MAC>Security Sign-On message with different choices.

Table 54: Security Sign-On Response message structure

Security_Sign-On_Response (){	Bits	Bytes	Bit Number / Description	Parameter bytes
Public_Key_Alg		1	Public key algorithm choices:	P _{pka} :
PKA_Reserved	7		7..1: Reserved, shall be 0	64
PKA_DH_512	1		0: (yes/no) Diffie-Hellman, 512 bits	
Hash_Alg		1	Hash algorithm choices:	P _{ha} :
HA_Reserved	7		7..1: Reserved, shall be 0	20
HA_HMACSHA1	1		0: (yes/no) HMAC-SHA1	
Encryption_Alg		1	Encryption algorithm choices:	P _{ea} :
EA_Reserved	6		7..2: Reserved, shall be 0	8
EA_DES_56	1		1: (yes/no) DES, 56-bit key	
EA_DES_40	1		0: (yes/no) DES, 40-bit key	
				8
Nonce_Size		1	Nonce size choices:	P _{ns} :
NS_Reserved	7		7..1: Reserved, shall be 0	8
NS_64	1		0: (yes/no) 8 random bytes	
Reserved	32	4	Reserved for future use, shall be 0	
}				

5.7.9.3 <MAC>Main Key Exchange (Single-cast Downstream)

The Main Key Exchange message is used to start a cookie-independent key exchange with the NIU, and also instructs the NIU whether to update its cookie value and clone counter value.

Table 55: Main Key Exchange message structure

Main_Key_Exchange (){	Bits	Bytes	Bit Number / Description
Connection_ID	32	4	MAC connection identifier
Flags		1	
Reserved	4		7..4: shall be 0
FL_Initializing	1		3: (yes/no) first ever key exchange
FL_Update_Cookie	1		2: (yes/no) make new cookie value
FL_Update_Counter	1		1: (yes/no) increment clone counter
FL_Session_Key	1		0: select session key 0 or 1
Reserved	8	1	Reserved for future use, shall be 0
Nonce		P _{ns}	Random string nonce1
DH_Modulus		P _{pka}	Diffie-Hellman modulus m
DH_Generator		P _{pka}	Diffie-Hellman generator g
DH_Public_X		P _{pka}	Diffie-Hellman public value X
}			

The FL_Session_Key bit specifies which session key of the security context to update.

If the FL_Update_Counter bit is set, it instructs the NIU to increment its clone detection counter.

If the FL_Update_Cookie bit is set, it instructs the NIU to generate a new cookie value to be used for future authentication and key exchanges, and to reset the clone detection counter to zero.

Any updates to the cookie, clone counter, or their associated sequence number bits do not take effect until the following <MAC>Connect Confirm message is received by the NIU.

If the FL_Initializing bit is set, it tells the NIU that the Authenticator field in the response will be ignored.

The sizes of the multi-byte fields are determined by the parameters of the algorithms selected during security sign-on (see subclause 5.7.9.1).

The INA will use its own private Diffie-Hellman value, x , together with the fields of the response message from the NIU to derive the new session key value, as well as any new value for the cookie (see subclause 5.7.2).

5.7.9.4 <MAC>Main Key Exchange Response (Upstream)

The Main Key Exchange Response message authenticates the NIU and completes the cookie-independent key exchange with the INA. It also contains the current value of the clone detection counter.

Table 56: Main Key Exchange Response message structure

Main_Key_Exchange_Re-sponse (){	Bits	Bytes	Bit Number / Description
Connection_ID	32	4	MAC connection identifier
Flags		1	
Reserved FL_Cookie_SN	6		7..2: shall be 0
FL_Counter_SN	1		1: cookie sequence number
	1		0: clone counter sequence number
Clone_Counter	8	1	Current clone counter value
Nonce		P _{ns}	Random string nonce2
Authenticator		P _{ha}	Authentication value auth
DH_Public_Y		P _{pka}	Diffie-Hellman public value Y
}			

The `FL_Counter_SN` bit is the current sequence number of the clone detection counter. The `Clone_Counter` field is the current value of the counter. A clone collision has been detected if the INA finds a mis-match from the expected value.

The `FL_Cookie_SN` bit is the sequence number of the cookie used for authentication.

If the `FL_Update_Cookie` bit was set by the INA, the NIU will generate a new cookie value and complement the cookie sequence number bit. It will also reset the clone counter value to zero and clear the clone counter sequence number bit.

If the `FL_Update_Counter` bit was set by the INA, the NIU will increment the value of the clone counter (modulo 256) and complement the clone counter sequence number bit.

Any updates to the cookie, clone counter, or their associated sequence number bits do not take effect, and shall not be committed to non-volatile storage, until the following `<MAC>Connect Confirm` message is received by the NIU.

The NIU uses its private Diffie-Hellman value, y , together with the message fields to derive the new session key value, as well as any new value for the cookie (see subclause 5.7.2).

5.7.9.5 <MAC>Quick Key Exchange (Single-cast Downstream)

The Quick Key Exchange message is used to start a cookie-dependent key exchange with the NIU, and also instructs the NIU whether to update its clone counter value.

Table 57: Quick Key Exchange message structure

Quick_Key_Exchange (){	Bits	Bytes	Bit Number / Description
Connection_ID	32	4	MAC connection identifier
Flags	8	1	
Reserved	6		7..2: shall be 0
<code>FL_Update_Counter</code>	1		1: (yes/no) increment clone counter
<code>FL_Session_Key</code>	1		0: select session key 0 or 1
Reserved	8	1	Reserved for future use, shall be 0
Nonce		P_{ns}	Random string nonce¹
}			

The `FL_Session_Key` bit specifies which session key of the security context to update.

If the `FL_Update_Counter` bit is set, it instructs the NIU to increment its clone detection counter.

The INA will use its knowledge of the cookie value together with the fields of the response message from the NIU to derive the session key value (see subclause 5.7.3).

5.7.9.6 <MAC>Quick Key Exchange Response (Upstream)

The Quick Key Exchange Response message authenticates the NIU and completes the cookie-dependent key exchange with the INA. It also contains the current value of the clone detection counter.

Table 58: Quick Key Exchange Response message structure

Quick_Key_Exchange_Re-sponse (){	Bits	Bytes	Bit Number / Description
Connection_ID	32	4	MAC connection identifier
Flags		1	
Reserved	6		7..2: shall be 0
FL_Cookie_SN	1		1: cookie sequence number
FL_Counter_SN	1		0: clone counter sequence number
Clone_Counter	8	1	Current clone counter value
Nonce		P_{ns}	Random string nonce2
Authenticator		P_{ha}	Authentication value auth
}			

The FL_Cookie_SN bit is the sequence number of the cookie used for authentication.

The FL_Counter_SN bit is the current sequence number of the clone detection counter. The **Clone_Counter** field is the current value of the counter. A clone collision has been detected if the INA finds a mis-match from the expected value.

If the FL_Update_Counter bit was set by the INA, the NIU will increment the value of the clone counter (modulo 256) and complement the clone counter sequence number bit. The updated values do not take effect, and shall not be committed to non-volatile storage, until the following <MAC>Connect Confirm message is received by the NIU.

The NIU uses the cookie value together with the message fields to derive the session key value (see subclause 5.7.3).

5.7.9.7 <MAC>Explicit Key Exchange (Single-cast Downstream)

The Explicit Key Exchange message is used to securely deliver an existing session key value to the NIU, and also instructs the NIU whether to update its clone counter value.

Table 59: Explicit Key Exchange message structure

Explicit_Key_Exchange (){	Bits	Bytes	Bit Number / Description
Connection_ID	32	4	MAC connection identifier
Flags		1	
Reserved	6		7..2: shall be 0
FL_Update_Counter	1		1: (yes/no) increment clone counter
FL_Session_Key	1		0: select session key 0 or 1
Reserved	8	1	Reserved for future use, shall be 0
Nonce		P_{ns}	Random string nonce1
Encryptedkey		P_{ea}	Encrypted session key
}			

The FL_Session_Key bit specifies which session key of the security context to update.

If the FL_Update_Counter bit is set, it instructs the NIU to increment its clone detection counter.

The INA has used its knowledge of the cookie value to encrypt the session key value (see subclause 5.7.4).

5.7.9.8 <MAC>Explicit Key Exchange Response (Upstream)

The Explicit Key Exchange Response message authenticates the NIU and acknowledges receipt of the delivered key. It also contains the current value of the clone detection counter.

Table 60: Explicit Key Exchange Response message structure

Explicit_Key_Exchange_Response (){	Bits	Bytes	Bit Number / Description
Connection_ID	32	4	MAC connection identifier
Flags		1	
Reserved	6		7..2: shall be 0
FL_Cookie_SN	1		1: cookie sequence number
FL_Counter_SN	1		0: clone counter sequence number
Clone_Counter	8	1	Current clone counter value
Nonce		P _{ns}	Random string nonce2
Authenticator		P _{ha}	Authentication value auth
}			

The FL_Cookie_SN bit is the sequence number of the cookie used for authentication and session key decryption. If the INA determines that it has used the wrong cookie for session key encryption it will re-issue the <MAC>Explicit Key Exchange using the old cookie value.

The FL_Counter_SN bit is the current sequence number of the clone detection counter. The Clone_Counter field is the current value of the counter. A clone collision has been detected if the INA finds a mis-match from the expected value.

If the FL_Update_Counter bit was set by the INA, the NIU will increment the value of the clone counter (modulo 256) and complement the clone counter sequence number bit. The updated values do not take effect, and shall not be committed to non-volatile storage, until the following <MAC>Connect Confirm message is received by the NIU.

The NIU uses the cookie value together with the message fields to decrypt the session key value (see subclause 5.7.4).

5.7.9.9 <MAC>Wait (Upstream)

The Wait message is used by the NIU to extend the time the INA waits for a reply to a given message. Upon receiving it, the INA will reset its time-out value and retry count (see subclause 5.7.8.1).

Table 61: Wait message structure

Wait (){	Bits	Bytes	Bit Number / Description
Connection_ID	32	4	MAC connection identifier
Message_Type	8	1	Type of message from INA
Reserved	8	1	Reserved for future use, shall be 0
}			

The Message_Type field is the message type value of the message received from the INA being processed. If the message is specific to a connection, the Connection_ID field identifies which; otherwise this field is zero. The NIU indicates that it is currently unable to send a reply to the message.

6 Interactive STB / Data Modem Mid Layer Protocol

This clause describes the mid layers to be used when the present standard is used to implement Interactive STB respectively Data Modem applications. Three solutions are given for this application, Direct IP, Ethernet MAC bridging and PPP. Direct IP is mandatory for both INA and NIU, the other two solutions are optional. Interoperability testing will be performed only on Ethernet MAC bridging until 6 month after the ratification of this specification by ETSI.

6.1 Direct IP

The goal of this subclause is to allow compatible and interoperable implementations for transmitting IP datagrams [16] over ATM AAL5 [13] and DVB Multiprotocol Encapsulation [3], as used by the present document for upstream and downstream transmission.

6.1.1 Framing

INA and NIU/STB shall support an MTU size of 1 500 Byte.

6.1.1.1 Upstream and OOB Downstream

The IP datagram shall be carried as such in the payload of the AAL5 CPCS-PDU. This method is described in RFC 1483 [13] as VC based multiplexing for routed protocols and is generally also known as null encapsulation.

6.1.1.2 IB Downstream

The IP datagram shall be carried as such in the DVB Multiprotocol Encapsulation sections of EN 301 192 [3], LLC_SNAP_flag is set to zero.

6.1.2 Addressing

In upstream framing structure and in downstream out-of-band framing structure, the addressing of a specific NIU/STB is done with a VPI/VCI pair. At least one VPI/VCI pair is assigned per NIU/STB. The following VPI/VCI pairs are reserved:

VPI / VCI	Remark
any / 0..0x1F	reserved for ATM use
0 / 0x20	reserved for DAVIC use
0 / 0x21	reserved for DVB MAC messages
0 / 0x22	reserved for broadcast

All other VPI/VCI pairs can be assigned by the INA for carrying IP traffic. The VPI/VCI is provided through the DVB MAC protocol.

6.1.2.1 IP Broadcast and Multicast from STB/NIU to INA

All upstream IP broadcast and multicast packets shall be transmitted with an upstream VPI/VCI given in a MAC connect message.

6.1.2.2 IP Broadcast and Multicast from INA to STB/NIU

IB downstream

For IB downstream, IP broadcast and multicast shall be carried out according to EN 301 192 [3] as described below:

IB downstream IP broadcast shall be transmitted with the broadcast MAC address FF:FF:FF:FF:FF:FF. An IP multicast group is joined according to the IGMP protocol [12]. Additionally, the INA may assign a new DVB MAC connection to the NIU/STB for that purpose, including a multicast MAC address. IB downstream multicast shall then be transmitted with that multicast MAC address.

OOB downstream

OOB downstream IP broadcast shall be transmitted with a VPI/VCI value of 0/0x22. An IP multicast group is joined according to the IGMP protocol [12]. Additionally, the INA may assign a new MAC connection to the NIU/STB for that purpose. QPSK downstream multicast shall then be transmitted with the VPI/VCI given in the corresponding MAC connect message.

6.1.3 IP Address Assignment

After receiving the MAC Connect confirm message, the NIU/STB shall use either the BOOTP or the DHCP protocol according to RFC 951 [15] and to RFC 2131 [14] to get an IP address from the network, unless a fixed IP address was assigned to the NIU/STB by the operator and made known to the INA. All additional IP addresses of customer premises equipment connected to the NIU/STB shall be assigned through BOOTP or DHCP, unless fixed IP addresses have been assigned by the operator. Singlecast downstream traffic with a destination IP address not assigned through BOOTP, DHCP or the operator shall be discarded by the INA. Upstream traffic with a source host IP address not assigned through BOOTP, DHCP or the operator shall be discarded by the NIU/STB and by the INA.

6.1.4 INA Interfaces (informative)

t.b.d.

6.1.5 NIU/STB Interfaces (informative)

t.b.d.

6.2 Ethernet MAC Bridging

The goal of this subclause is to allow compatible and interoperable implementations for transmitting ISO 8802-3 Ethernet MAC frames [10] over ATM AAL5 [13] and DVB Multiprotocol Encapsulation [3], as used by the present standard for upstream and downstream transmission.

6.2.1 Framing

6.2.1.1 Upstream and OOB Downstream

The Ethernet MAC frame shall be carried in the payload of the AAL5 CPCS-PDU as described in RFC 1483 [13] as LLC encapsulation for bridged Ethernet/802.3 PDUs, using PID 0x00-07 (LAN FCS is not transmitted). No padding bytes are inserted between the LLC/SNAP header and the Ethernet MAC frame.

6.2.1.2 IB Downstream

The Ethernet MAC frame shall be carried in the payload of the DVB Multiprotocol Encapsulation sections as described in EN 301 192 [3], LLC_SNAP_flag is set to one. The value of the LLC/SNAP header is 0xAA-AA-03-00-80-C2-00-07.

6.2.2 Addressing

In upstream framing structure and in downstream out-of-band framing structure, the addressing of a specific NIU/STB is done with a VPI/VCI pair. At least one VPI/VCI pair is assigned per NIU/STB. The following VPI/VCI pairs are reserved:

VPI / VCI	Remark
any / 0..0x1F	reserved for ATM use
0 / 0x20	reserved for DAVIC use
0 / 0x21	reserved for DVB MAC messages
0 / 0x22	reserved for broadcast

All other VPI/VCI pairs can be assigned by the INA for carrying Ethernet traffic. The VPI/VCI is provided through the DVB MAC protocol.

6.3 PPP

The goal of this subclause is to allow compatible and interoperable implementations for transmitting PPP packets over ATM AAL5 and DVB Multiprotocol Encapsulation [3], as used by the present standard for upstream and downstream transmission.

6.3.1 Framing

The implementation shall be done according to the RFC2364, as mentioned in paragraph 5.

6.3.1.1 Upstream and OOB Downstream

The PPP frame shall be carried as such in the payload of the AAL5 CPCS-PDU. This method is described in RFC 2364 [13] (Figure 1). The flag sequences, that delimit the beginning and the end of each frame, don't exist any more. The Asynchronous-Control-Character-Map (ACCM) is not negotiated. In this way, the stuffing procedure is no longer necessary.

6.3.1.2 IB Downstream

The PPP datagrams shall be carried in the payload of the DSM-CC sections as described in EN 301 192 [3] (DVB multiprotocol encapsulation) with the LLC_SNAP_flag set to one. The encapsulation of PPP into LLC/SNAP is defined in RFC2364 "PPP over AAL5" (with the NLPID value for PPP set to 0xCF).

6.3.2 Addressing

In upstream framing structure and in downstream out-of-band framing structure, the addressing of a specific NIU/STB is done with a VPI/VCI pair. At least one VPI/VCI pair is assigned per NIU/STB. The following VPI/VCI pairs are reserved:

VPI / VCI	Remark
any / 0..0x1F	reserved for ATM use
0 / 0x20	reserved for DAVIC use
0 / 0x21	reserved for DVB MAC messages
0 / 0x22	reserved for broadcast

All other VPI/VCI pairs can be assigned by the INA for carrying PPP traffic. Each PPP connection will be associated to one VPI/VCI provided through the MAC DVB RC protocol.

6.3.3 IP Address Assignment

After receiving the MAC Connect confirm message, the NIU/STB uses IPCP protocol included in the PPP protocol, according to RFC 1332 to get an IP address from the network. The PPP protocol supports the case of a fixed IP address assigned to the STB/NIU.

In the case a fixed IP address has been assigned to the NIU/STB by the operator, the IPCP protocol shall be used to make this IP address known to the INA. The PPP IPCP *Configure-Request* of the NIU/STB states which IP-address is used.

The INA can provide an(other) IP address by making this option, and returning a valid IP-address. The NIU/STB shall use this IP address even in the case, the NIU/STB has a fixed one.

6.3.4 Additional IP addresses

In the case the NIU/STB is also connected to customer premises equipment by a LAN, one of the following IP address assignment schemes shall be implemented:

- 1) the LAN has its own IP subnet address and subnet mask, in this case the NIU/STB acts like a router i.e. the IP subnet address and subnet mask of the LAN is completely independent of the INA; or
- 2) BOOTP/DHCP messages from the LAN are sent transparently through the PPP link to a server at the INA side.

Singlecast downstream traffic with a destination IP address not assigned through PPP or BOOTP/DHCP shall be discarded by the INA. Upstream traffic with a source host IP address not assigned PPP or BOOTP/DHCP shall be discarded by the NIU/STB and by the INA.

6.3.5 Security

The PAP or CHAP protocols will supply authentication and authorization mechanisms both included in PPP.

6.3.6 INA Interfaces (informative)

t.b.d.

6.3.7 NIU/STB Interfaces (informative)

t.b.d.

Annex A (informative): MAC State Transitions and Time Outs

A.1 Ranging and Calibration

Figure A.1 describes the ranging and calibration procedure in detail.

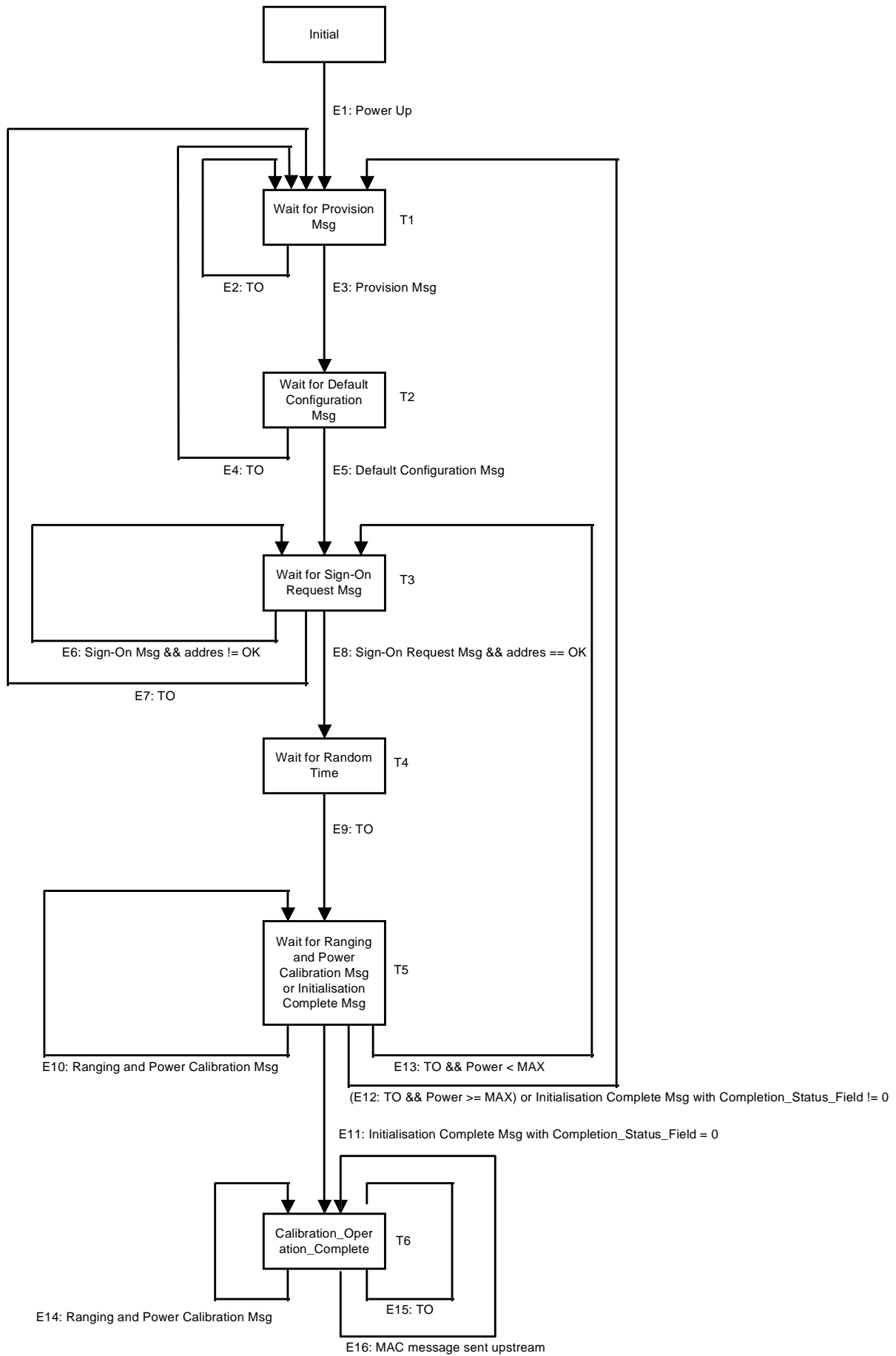

Figure A.1: State Diagram for Ranging and Calibration

The boxes represent states, state-transitions are represented by arrows. State-transitions are triggered by events, denoted by: "Ex: <event>". Triggers are either the reception of MAC-messages or Time-Outs. An event can lead to a state-transition depending on a condition, this is denoted by "Ex: <event> && <condition>".

A time-out timer runs in all the states. The values of these time-out counters are denoted by Tx.

On the following pages the events are accompanied by actions that are performed by the state machine during the state transition. Some actions are performed only under a certain condition. To make this clear, "if then else" constructions are used.

- E1 Power up:
 Tune to any downstream channel
 (re)set timeout to T1
- E2 Time Out received:
 Tune to next downstream channel
 (re)set timeout to T1
- E3 Provision Msg received:
 IF current DS freq. != provision Freq.
 Tune provision channel
 (re)set timeout to T2
- E4 Time Out received:
 Do nothing
 (re)set timeout to T1
- E5 Default Configuration Msg received:
 Tune to service channel
 TimeOffset = Absolute_Time_Offset
 Output_Power_Level = MIN_Power_Level
 Power_Retry_Count = 0
 Sign-On_Retry_Count = 0
 (re)set timeout to T3
- E6 Sign-On Msg && address != OK:
 Do nothing
 (re)set timeout to T3
- E7 Time Out received:
 Do nothing
 (re)set timeout to T1
- E8 Sign-On Msg && address == OK:
 Sign-On_Retry_Count = min (Sign-On_Retry_Count+1, 255)
 (re)set timeout to T4
- E9 Time Out received:
 Send Sign-On Response Msg in ranging area
 (re)set timeout to T5
- E10 Ranging and Power Calibration Msg:
 Time_Offset = Time_Offset + Time_Offset_Value
 Output_Power_Level = Output_Power_Level + Power_Control_Setting x 0,5 dB
 IF Ranging_Slot_Included
 send Ranging and Power Calibration Response Msg on Ranging_Slot_Number
 ELSE
 send Ranging and Power Calibration Response Msg in ranging area
 (re)set timeout to T5
- E11 Initialization Complete Msg with Completion_Status_Field = 0:
 (re)set timeout to T6

- E12 (Time Out received && Power \geq MAX) or Initialization Complete Msg with Completion_Status_Field \neq 0:
Do nothing
(re)set timeout to T1
- E13 Time Out received && Power $<$ MAX:
Power_Retry_Count++
IF Power_Retry_Count $<$ Sign_On_Incr_Pwr_Retry_Count
Do Nothing
ELIF Tuned to Backup Service Channel
Tune to Service Channel
Output_Power_Level = min (Output_Power_Level + x dB, MAX_Power_Level)
Power_Retry_Count = 0
ELIF Service Channel \neq Backup Service Channel (x \in [0,5...2])
Tune to Backup Service Channel
Power_Retry_Count = 0
ELSE
Output_Power_Level = min (Output_Power_Level + x dB, MAX_Power_Level)
Power_Retry_Count = 0
(re)set timeout to T3 (x \in [0,5...2])
- E14 Ranging and Power Calibration Msg:
Absolute_Time_Offset = Absolute_Time_Offset + Time_Offset_Value
Output_Power_Level = Output_Power_Level + Power_Control_Setting x 0,5 dB
IF Ranging_Slot_Included
send Ranging and Power Calibration Response Msg on Ranging_Slot_Number
ELSE
send Ranging and Power Calibration Response Msg in ranging area
(re)set timeout to T6
- E15 Time Out received
Send Idle Msgs
(re)set timeout to T6
- E16 MAC message sent upstream
(re)set timeout to T6

Table A.1 links the timeout of the State Transition Diagram to the timeouts.

Table A.1: TimeOuts NIU SignOn STD

Timeout	Description	Code (see Def. Conf. Msg.)
T1	Provision Interval	0x31fixed 900 ms
T2	Default Configuration Interval	0x32
T3	Sign-On Message Interval	0x332
T4	Random (ResponseCollectionTimeWindow)	see Sign on Requ. Msg.
T5	Sign On Response -> Rang. and Power Calibr. Sign On Resp. -> Initial. Complete Rang. and Power Calibr. Resp. -> Rang. and Poer Cal. Rang. and Power Calibr. Resp. -> Initial. Complete	0x3
T6	Idle Interval	see Def. Conf. Msg.

A.2 Connection Establishment

Two cases of connection establishment exist: connection establishment of the 1st or default connection, and connection establishment of additional connections after the default connection has been successfully established.

If the STB detects the continuous loss of carrier or framing for longer than LofTimeout, then the STB will consider all connections released and will go to the Wait for Login state (T0?).

Default Connection Establishment

This procedure is started after a successful Sign-On and Calibration procedure. A special case exists when the STB loses the Initialization Complete Message but receives a Connect Message. In this special case, the STB shall proceed as if the Initialization Complete Message had been received.

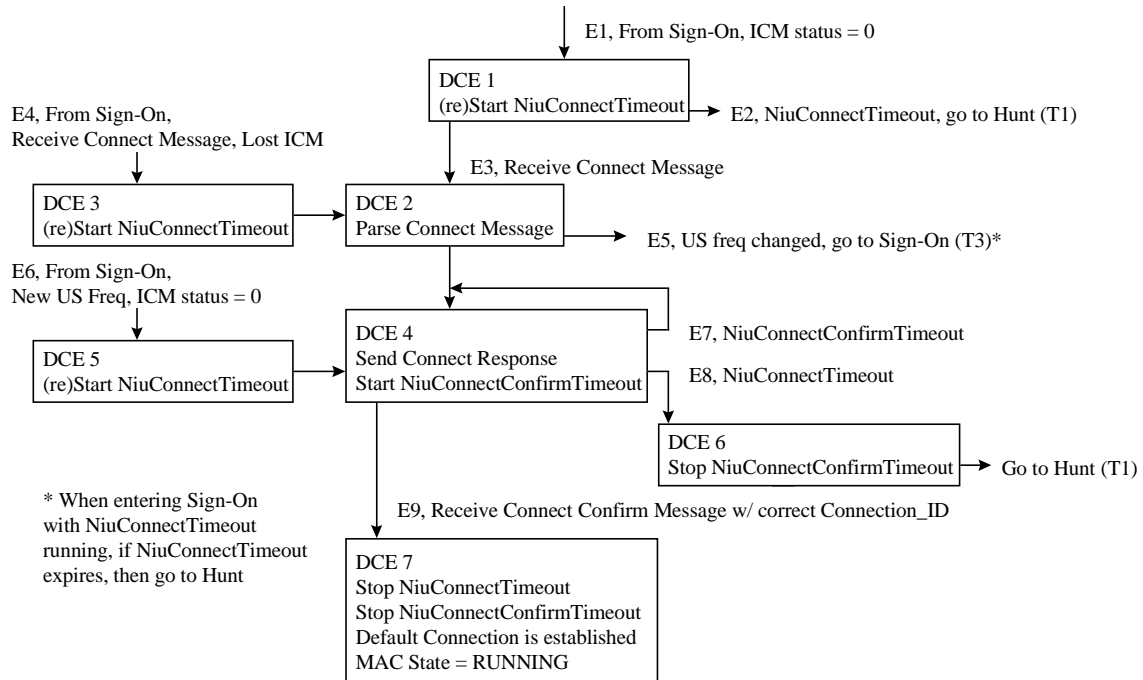

Subsequent Connection Establishment

This procedure can be entered only when the STB has at least one operating (i.e. not STOPPED via a TCM) connection.

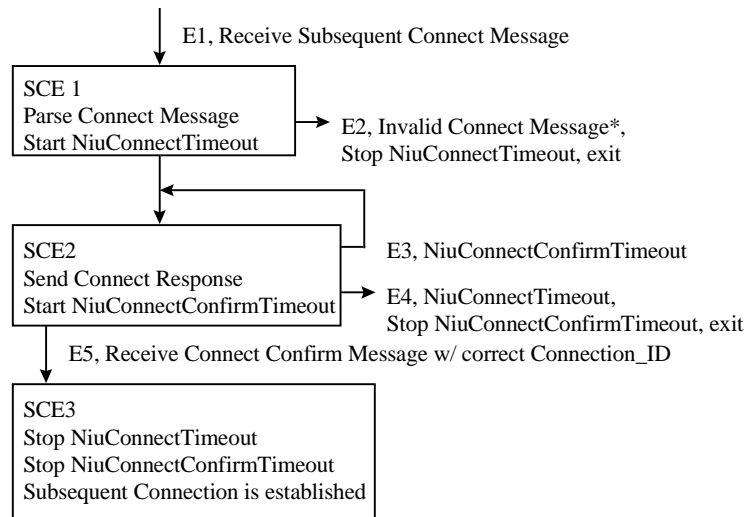

* Subsequent Connect Message Validity

```

if (US frequency is different than the current US frequency) {
    message invalid
} else if (Connect Message contains both an IB and OOB DS frequency) {
    message invalid
} else if (Connect Message contains an IB freq and the STB currently has an open connection on a different IB freq) {
    message invalid
} else if (Connect Message contains an OOB freq and the STB currently has an open connection on a different OOB freq) {
    message invalid
}
  
```

A.3 Connection Release

The STB may release connections only when it has at least one operating (i.e. not STOPPED by TCM) connection. If the STB has its number of connections reduced to one connection then the remaining connection is considered the default connection.

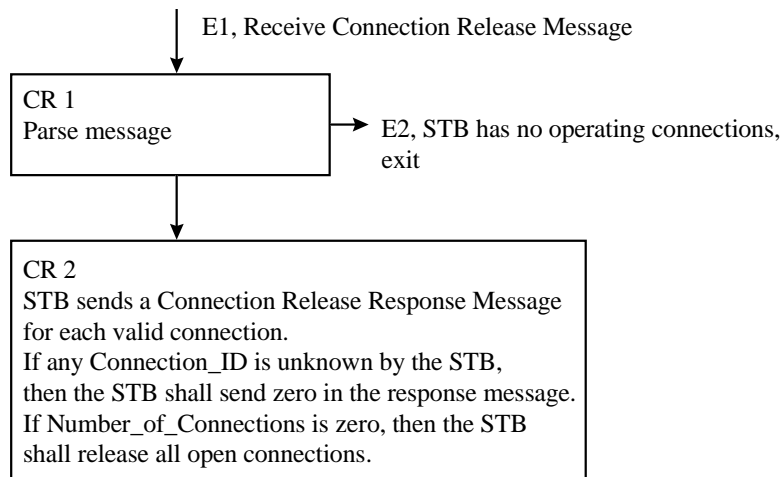

A.4 Reservation Process

The figure below gives a state diagram of the reservation process. The boxes represent states, state-transitions are represented by arrows. State-transitions are triggered by events, denoted by: "Ex:<event>". Triggers are either the reception of MAC messages or time outs. An event can lead to a state-transition depending on a condition; this is denoted by "Ex:<event>&&<condition>".

A pending slot is defined as a slot for which no reservation request has been sent yet.

A requested slot is defined as a slot for which a reservation request has already been sent, but which is not yet granted.

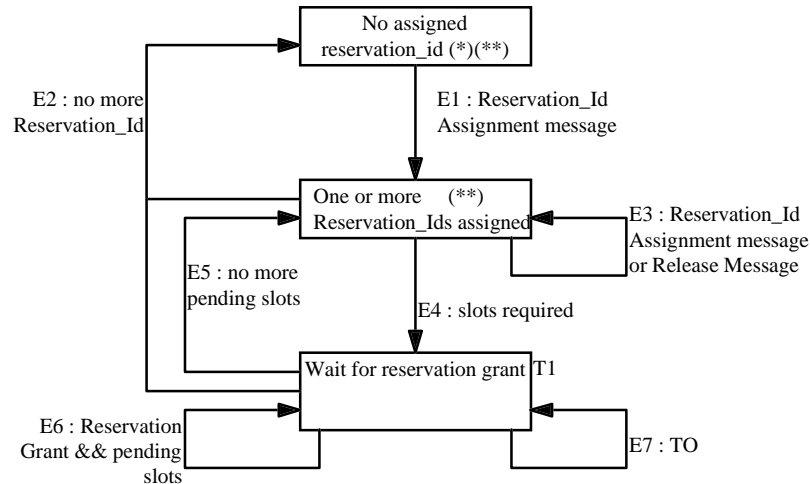

(*) "No assigned Reservation_id" State is to be linked to the state diagram of connection establishment process.

(**) No Time-Out is associated to this state since when transition shall occur is not in the scope of the specification.

E1 Reservation_Id Assignment message:

If a "Reservation_Id assignment" message is received with a valid connection_id

send a "Reservation_id response" message

consider new parameters

go to "One or more Reservation_Ids assigned"

E2 No more reservation_Id:

If a "Release" message closes the last connection with an assigned reservation_id,

Delete all slots allocated in reservation region for this connection

go to "No assigned reservation_id" state

If a "Reprovisioning" message is received with "Delete_Reservation_IDs" bit set,

Delete all slots allocated in reservation region

go to "No assigned reservation_id" state

- E3 "Reservation_Id Assignment" message or "Release" message
- If a "Release" message closes the connection with an assigned reservation_id (but not the last),
- Delete all slots allocated in reservation region for this connection
 - Stay in same state
- If a "Reservation_Id assignment" message is received with a valid connection_id
- consider new parameters
 - send a "Reservation_ID_Response" message
 - Stay in same state
- E4 Reservation slots are required by the NIU:
- Send a "Reservation Request" message
- with reservation_id corresponding to the connection
 - maintain count of pending slots and requested slots for this connection
- Set a timer to T1 (equal to "grant_protocol_timeout" associated to the reservation_id)
- Go to "Wait for reservation grant" state
- E5 Reservation Grant message granting all requested slots:
- if a "reservation grant" message grants all the previous requests (i.e. with "remaining_slot_count" field set to 0) and no pending slots
- Disable active timers
 - Go to "One or more Reservation_IDs Reservation_ID assigned" state

- E6 Reservation Grant message but requested slots still to be granted:
- if a "reservation grant" message grants previous requests (but not all or some with "remaining_slot_count" field different from 0)
- For connection with request not completely granted
- Set timer of the connection to T1 (equal to "grant_protocol_timeout" associated to the reservation_id)
 - Update number of requested slots with "granted slot count" field
- If "remaining_slot_count" < 15 and (pending_slot_count != 0 or requested_slot_count != remaining_slot_count)
- Send a "Reservation Request" message
 - with reservation_id corresponding to the connection
 - maintain count of pending slots and requested slots for this connection
- For completely granted connection
- disable timer of the connection
 - set number of requested slots to 0 for this connection
 - If pending slots exist
 - Send a "Reservation Request" message
 - with reservation_id corresponding to the connection
 - maintain count of pending slots and requested slots for this connection
 - Set timer of the connection to T1 (function of "grant_protocol_timeout" associated to the reservation_id)
- If new slots are required for a connection, update number of pending slots.
- Stay in same status
- E7 Time Out received:
- If an active timer elapsed
- Send a reservation status request message for the associated connection
- Set timer of the connection to T1 (function of "grant_protocol_timeout" associated to the reservation_id)
- If new slots are required for a connection, update number of pending slots.
- Stay in same status

Time-out T1 is dynamically set by the INA in the "Reservation_Id_Assignment" message (grant_protocol_timeout parameter).

A.5 Re-calibration

The STB may be re-calibrate whenever it has at least one open (i.e. STOPPED or RUNNING) connection.

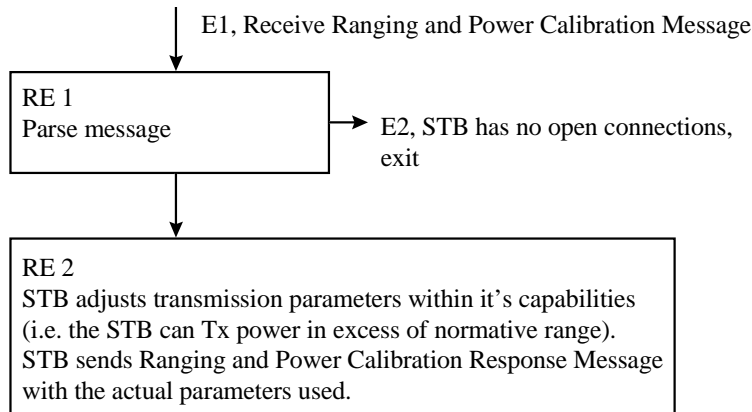

A.6 Reprovision Message

The STB can be re-provisioned whenever it has at least one operating connection.

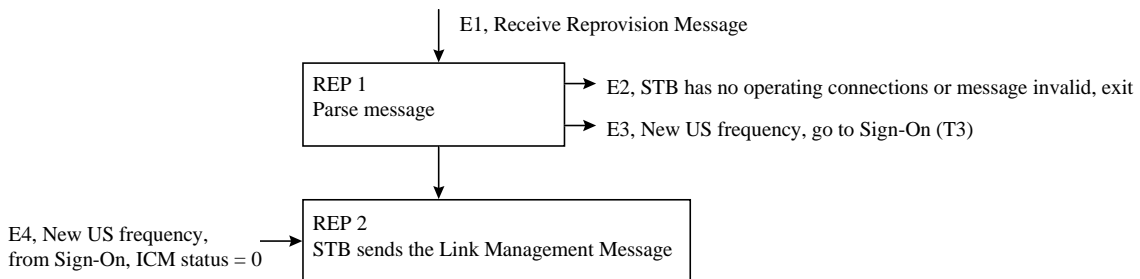

A.7 Transmission Control Message

The Transmission Control Message (TCM) controls aspects of upstream and downstream transmission. The commands are sent to the STB in either broadcast or singlecast mode. The STB is in one of the following MAC states:

- RUNNING, the STB has at least one operating connection;
- STOPPED, the STB has received a TCM Stop Upstream Transmission command;
- ERROR, the STB has received a ICM with non-zero Completion_Status_Field; and
- NONE, the STB has no open connections.

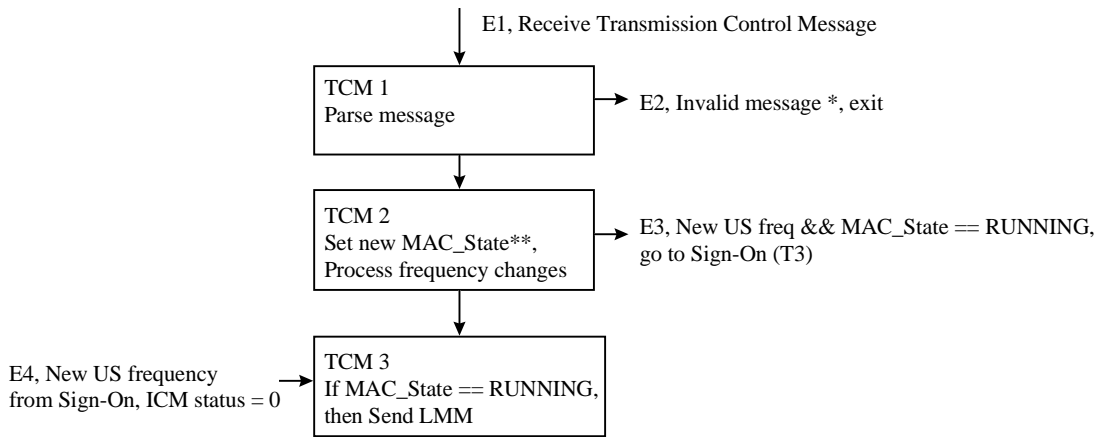

* Invalid TCM

Besides invalid parameter values, the received TCM will be considered invalid if
(Start_Upstream_Transmission && Stop_Upstream_Transmission) or (Old_Frequency != CurrentFrequency)
in which case the STB will ignore the message.

** new MAC state

```

if (Start_Upstream_Transmission == 0 && Stop_Upstream_Transmission == 0) {
    New_MAC_State = Old_MAC_State
} else if (Start_Upstream_Transmission == 0 && Stop_Upstream_Transmission == 1) {
    if (Old_MAC_State == ERROR) New_MAC_State = ERROR
    else New_MAC_State = STOPPED
} else if (Start_Upstream_Transmission == 1 && Stop_Upstream_Transmission == 0) {
    If (Old_MAC_State == ERROR && Broadcast) New_MAC_State = ERROR
    else New_MAC_State = RUNNING
}
  
```

A.8 Status Request Message

The STB can be queried for status whenever it has at least one operating connection.

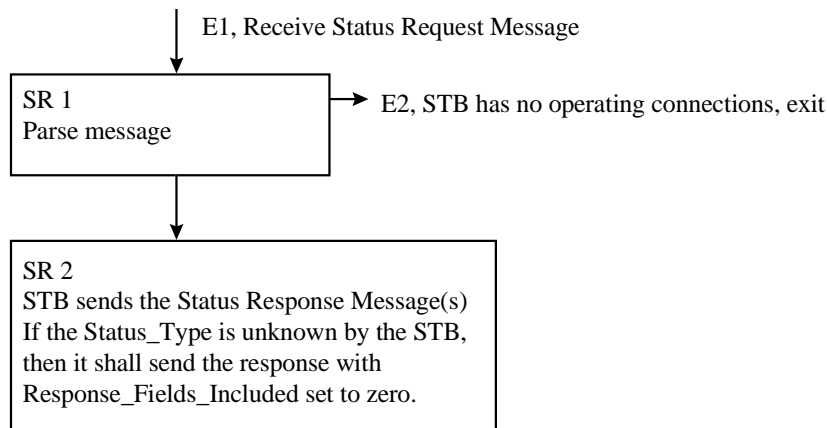

A.9 Idle Message

The Idle Message is sent during periods of upstream MAC message inactivity that exceed a non-zero Idle_Interval by the STB whenever it has at least one operating connection.

Bibliography

The following material, though not specifically referenced in the body of the present document (or not publicly available), gives supporting information.

DVB-A008 (1995): "Commercial requirements for asymmetric interactive services supporting broadcast to the home with narrowband return channels".

DAVIC 1.5 Specification: "DAVIC System Reference Model".

EN 300 429: "Digital Video Broadcasting (DVB); Framing structure, channel coding and modulation for cable systems".

History

Document history		
V1.1.1	November 1998	Publication
V1.2.1	January 1999	One-step Approval Procedure OAP 9921: 1999-01-22 to 1999-05-21
V1.2.1	June 1999	Publication