

# EN 301 169-2 V1.5.3 (1999-02)

---

*European Standard (Telecommunications series)*

**Equipment practice;  
Engineering requirements for outdoor enclosures;  
Part 2: Unequipped enclosures**

---

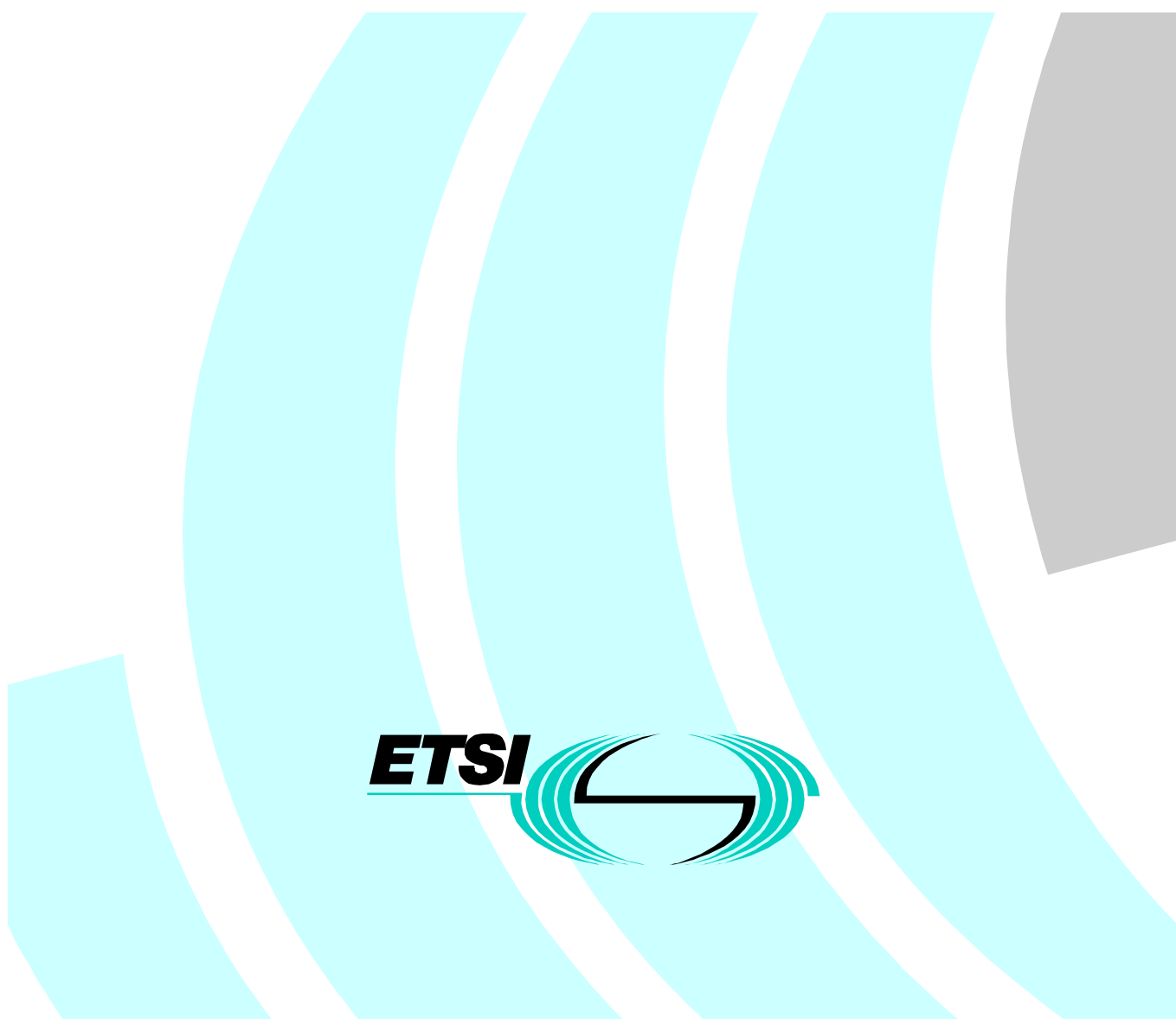

---

Reference

DEN/EE-00001-2 (atoi0jq0.PDF)

---

Keywords

equipment practice

**ETSI**

---

Postal address

F-06921 Sophia Antipolis Cedex - FRANCE

---

Office address

650 Route des Lucioles - Sophia Antipolis  
Valbonne - FRANCE  
Tel.: +33 4 92 94 42 00 Fax: +33 4 93 65 47 16  
Siret N° 348 623 562 00017 - NAF 742 C  
Association à but non lucratif enregistrée à la  
Sous-Préfecture de Grasse (06) N° 7803/88

---

Internet

[secretariat@etsi.fr](mailto:secretariat@etsi.fr)  
Individual copies of this ETSI deliverable  
can be downloaded from  
<http://www.etsi.org>  
If you find errors in the present document, send your  
comment to: [editor@etsi.fr](mailto:editor@etsi.fr)

---

**Copyright Notification**

No part may be reproduced except as authorized by written permission.  
The copyright and the foregoing restriction extend to reproduction in all media.

© European Telecommunications Standards Institute 1999.  
All rights reserved.

# Contents

Intellectual Property Rights.....	4
Foreword .....	4
Introduction .....	4
1 Scope.....	5
2 References.....	5
3 Definitions, symbols and abbreviations .....	6
3.1 Definitions .....	6
3.2 Symbols .....	6
3.3 Abbreviations.....	6
4 Definition of unequipped outdoor enclosures.....	6
4.1 Features.....	6
4.2 Internal equipment .....	7
5 Co-ordination dimensions for unequipped outdoor enclosures .....	7
5.1 General.....	7
5.2 Co-ordination dimensions .....	8
5.2.1 Height.....	8
5.2.1.1 Outside height (H) .....	8
5.2.1.2 Mounting aperture height ( $H_1$ ) .....	8
5.2.2 Width.....	8
5.2.2.1 Outside width (W) .....	8
5.2.2.2 Mounting aperture width ( $W_1$ ) .....	8
5.2.3 Depth.....	8
5.2.3.1 Outside depth (D) .....	8
5.2.3.2 Mounting aperture depth ( $D_1$ ) .....	9
5.3 Guidelines for plinth dimensions (optional).....	9
5.3.1 Outside height ( $H_p$ ).....	9
5.3.2 Outside width ( $W_p$ ).....	9
5.3.3 Outside depth ( $D_p$ ).....	9
5.4 Top cover dimensions.....	9
5.4.1 Outside width ( $W_T$ ).....	10
5.4.2 Depth ( $D_T$ ).....	10
5.5 Cabinet dimension values .....	10
<b>Annex A (informative): Illustrative figures .....</b>	<b>11</b>
Bibliography .....	13
History .....	14

---

## Intellectual Property Rights

IPRs essential or potentially essential to the present document may have been declared to ETSI. The information pertaining to these essential IPRs, if any, is publicly available for **ETSI members and non-members**, and can be found in SR 000 314: "*Intellectual Property Rights (IPRs); Essential, or potentially Essential, IPRs notified to ETSI in respect of ETSI standards*", which is available **free of charge** from the ETSI Secretariat. Latest updates are available on the ETSI Web server (<http://www.etsi.org/ipr>).

Pursuant to the ETSI IPR Policy, no investigation, including IPR searches, has been carried out by ETSI. No guarantee can be given as to the existence of other IPRs not referenced in SR 000 314 (or the updates on the ETSI Web server) which are, or may be, or may become, essential to the present document.

---

## Foreword

This European Standard (Telecommunications series) has been produced by ETSI Technical Committee Equipment Engineering (EE).

The present document is part 2 of a multi-part EN covering Equipment practice; Engineering requirements for outdoor enclosures as identified below:

Part 1: "Equipped enclosures";

**Part 2: "Unequipped enclosures".**

<b>National transposition dates</b>	
Date of adoption of this EN:	12 February 1999
Date of latest announcement of this EN (doa):	31 May 1999
Date of latest publication of new National Standard or endorsement of this EN (dop/e):	30 November 1999
Date of withdrawal of any conflicting National Standard (dow):	30 November 1999

---

## Introduction

The present document is part 2 of a two-part EN, aimed at setting out on a common basis, the installation engineering requirements for telecommunication practice, housing equipment forming part of a telecommunications network. Part 2 specifies the engineering requirements for unequipped outdoor enclosures and part 1 the engineering requirements for outdoor enclosures.

The present document shall be referred to only when the supplier is asked for an unequipped outdoor enclosure ready to receive equipment supplied by different manufacturers.

The present document applies to the outdoor enclosures of all telecommunication equipment which forms part of a telecommunications network. The requirements for unequipped outdoor enclosures which this part lays down are based on the work of IEC Sub Committee 48D/WG 3.

Illustrative figures are contained in annex A.

---

# 1 Scope

The present document details requirements for outdoor enclosures which are supplied unequipped. The unequipped outdoor enclosures may be used for housing telecommunication equipment, forming part of a telecommunication network, installed outdoors on the ground. The unequipped outdoor enclosures are intended to accommodate various equipment from different suppliers, e.g. subracks in accordance with ETS 300 119-4 [4].

Requirements in the present document do not apply to outdoor enclosures or cabinets that can be entered by maintenance personnel.

The operating authorities should be given the data needed to help them plan infrastructure for outdoor applications. This includes equipment and traffic areas and installation transport (freight elevators, loading ramps, etc.) as well as locations of deployment for the outdoor equipment (streets, pavements, private areas, open public areas etc.).

---

# 2 References

The following documents contain provisions which, through reference in this text, constitute provisions of the present document.

- References are either specific (identified by date of publication, edition number, version number, etc.) or non-specific.
- For a specific reference, subsequent revisions do not apply.
- For a non-specific reference, the latest version applies.
- A non-specific reference to an ETS shall also be taken to refer to later versions published as an EN with the same number.

[1] Void.

[2] Void.

[3] ETS 300 119-3: "Equipment Engineering (EE); European telecommunication standard for equipment practice; Part 3: Engineering requirements for miscellaneous racks and cabinets".

[4] ETS 300 119-4: "Equipment Engineering (EE); European telecommunication standard for equipment practice; Part 4: Engineering requirements for subracks in miscellaneous racks and cabinets".

[5] Void.

[6] IEC 61969-2: "Sectional specification; Co-ordination dimensions for cases and cabinets; Outdoor enclosures".

[7] IEC 60917-2: "Modular order for the development of mechanical structures for electronic equipment practices - Part 2: Sectional specification - Interface co-ordination dimensions for the 25 mm equipment practice".

---

## 3 Definitions, symbols and abbreviations

### 3.1 Definitions

For the purposes of the present document, the following terms and definitions apply:

**cabinet:** a free-standing and self-supporting enclosure for housing electrical and/or electronic equipment, usually fitted with doors and/or side panels which may or may not be removable.

### 3.2 Symbols

For the purposes of the present document, the following symbols apply:

D	outside depth
$D_1$	mounting aperture depth
$D_p$	outside depth (plinth)
$D_r$	depth (top cover)
H	outside height
$H_1$	mounting aperture height
$H_p$	outside height (plinth)
W	outside width
$W_1$	mounting aperture width
$W_p$	outside width (plinth)
$W_r$	outside width (top cover)

### 3.3 Abbreviations

For the purposes of the present document, the following abbreviations apply:

IDF	Interconnect Distribution Frame
MDF	Main Distribution Frame
PSU	Power Supply Unit

---

## 4 Definition of unequipped outdoor enclosures

### 4.1 Features

Unequipped outdoor enclosures in the understanding of the present document comprise cabinets only, compliant with the following:

- intended to be used in open air conditions;
- for weather unprotected locations;
- for stationary use.

The present document does not address the aesthetic appearance of the enclosures.

The present document covers applications which are located on the ground, including:

- streets;
- pavements;
- private areas;
- open public areas.

## 4.2 Internal equipment

Unequipped outdoor enclosures in the understanding of the present document comprise unequipped outdoor cabinets. Unequipped outdoor enclosures and the internal equipment can be delivered by various suppliers.

Types of equipment to be accommodated include:

- Subracks according to ETS 300 119-4 [4].
- Miscellaneous equipment, e.g.:
  - MDF/IDF (Main Distribution Frame (MDF) / Intermediate Distribution Frame (IDF));
  - PSU (Power Supply Unit);
  - batteries;
  - climate control;
  - heat exchanger;
  - cable termination.

---

# 5 Co-ordination dimensions for unequipped outdoor enclosures

## 5.1 General

The co-ordination dimensions are to be understood as overall dimensions, distinguished between:

- cabinet / top cover;
- plinth.

The plinth is regarded as an option. The top cover is considered to be an integral part of the cabinet.

The co-ordination dimensions apply to outside dimensions and aperture dimensions as defined in ETS 300 119-3 [3], table 1. The principle of specifying values is based on general formulae, described in subclauses 5.2 to/and 5.4, and tables with a selection of the possible values. The dimension given in subclause 5.5 provide selections of required values.

To define appropriate co-ordination dimensions, the following basic assumptions have been made:

- The formulae for outside dimensions in part 1 and part 2 are identical. This is to achieve the same outside dimensions for economic reasons.
- The mounting aperture dimensions are based on the outside dimensions.

Mounting aperture dimensions, fastening points, space for external cable access, etc are according to ETS 300 119-3 [3], table 1, figures A.3 and A.4, with the exception of values W, D3 and D4 of figure A.3 and D MAX of figure A.4.

This is in order to guarantee compatibility with subracks as specified in ETS 300 119-4 [4].

## 5.2 Co-ordination dimensions

All dimensions are in millimetres (mm).

### 5.2.1 Height

#### 5.2.1.1 Outside height (H)

$$H = 600 + n \times 200$$

#### 5.2.1.2 Mounting aperture height ( $H_1$ )

$$H_1 = H - 200$$

NOTE: The variable  $n \times 200$  mm has been selected according to the IEC draft standard for outdoor enclosures IEC 61969-2 [6].

The constant 200 mm represents the difference between aperture height and outside height, and provides space for outdoor-specific functions.

$n = 0, 1, 2, 3, \dots$

### 5.2.2 Width

#### 5.2.2.1 Outside width (W)

$$W = 600 + n \times 100$$

#### 5.2.2.2 Mounting aperture width ( $W_1$ )

$$W_1 = W - 165$$

NOTE: The variable  $n \times 100$  mm has been selected according to the IEC draft standard for outdoor enclosures IEC 61969-2 [6].

The constant 165 mm represents the difference between aperture width and outside width, and provides space for outdoor-specific functions.

$n = 0, 1, 2, 3, \dots$

### 5.2.3 Depth

#### 5.2.3.1 Outside depth (D)

$$D = 300 + n \times 100$$



### 5.2.3.2 Mounting aperture depth ( $D_1$ )

$$D_1 = D - 100$$

NOTE: The variable  $n \times 100$  mm has been selected according to the IEC draft standard for outdoor enclosures IEC 61969-2 [6].

The constant 100 mm represents the difference between aperture depth and outside depth, and provides space for outdoor specific functions.

$n = 0, 1, 2, 3, \dots$

## 5.3 Guidelines for plinth dimensions (optional)

The following dimensions are to be considered as guidelines. There are too many variables which depend on the specific application. Thus, compulsory dimensions are not applicable.

### 5.3.1 Outside height ( $H_p$ )

$$H_p = n \times 25$$

### 5.3.2 Outside width ( $W_p$ )

$$W_p = W \pm n \times 25$$

### 5.3.3 Outside depth ( $D_p$ )

$$D_p = D \pm n \times 25$$

NOTE:  $n = 0, 1, 2$

It is recommended to extend 25 mm beyond each side of the enclosure footprint, which is an additional 50 mm beyond the cabinet width and depth. This is necessary to ensure sufficient cabinet mounting feet support by the plinth and to enable various features like mounting support brackets, AC cable conduits, fittings, etc.

If accommodation of outside AC cable conduits is necessary, the variable  $n \times 25$  mm may increase to maximum 150 mm at the entrance side by agreement between supplier and customer.

## 5.4 Top cover dimensions

Although the top cover is to be considered as an integral part of the outdoor cabinet, in particular with regard to the height dimension, the width and depth may need some more space beyond the maximum cabinet cross section for various reasons.

### 5.4.1 Outside width ( $W_r$ )

$$W_r = W + \text{max. } 50$$

### 5.4.2 Depth ( $D_r$ )

$$D_r = D + \text{max. } 50$$

NOTE: The outside width and depth of the roof may protrude a maximum of 25 mm on each side for the purpose of water outlets, gutters, air vents, dropping edges etc. Smaller elements mounted outside on covers such as door handles, hinges, etc. may also protrude within those limits.

## 5.5 Cabinet dimension values

The following outside cabinet dimension values can be required as shown in the tables hereafter. They do not represent all of the values that may be derived from the formulae in subclause 5.2 in order to limit cabinet size variants. In addition to the tabulated values, cabinets with outside and mounting aperture dimensions compliant with ETS 300 119-3 [3] are also allowed, although these do not comply with the formulae given in subclause 5.2.

The preferred dimensions, shown in bold, should be selected when ever feasible.

The preferred dimensions apply to the outside dimensions only: there is no need to select preferred aperture dimensions.

H (mm) (see note 1)	<b>600</b>	800	<b>1000</b>	<b>1200</b>	<b>1400</b>	1600	<b>1800</b>	2000	2200	2400
H <sub>1</sub> (mm) (see note 2)	400	600	800	1000	1200	1400	1600	1800	2000	2200

The minimum value H<sub>1</sub> is based on IEC 60917-2-2 [7], table 1a: H<sub>S</sub> = 300 mm plus 100 mm for different facilities. This is the starting point to accommodate subracks which cover plug-in unit heights for both 25 mm equipment practice (265 mm high) and 19" equipment practice (233,35 mm high, double euro-card).

W (mm) (see note 1)	<b>700</b>	<b>900</b>	1100	<b>1300</b>	1500	1700	<b>1900</b>	2100	2300	2500	2700	2900	3100
W <sub>1</sub> (mm) (see note 2)	535	735	935	1135	1335	1535	1735	1935	2135	2335	2535	2735	2935

The minimum value for W<sub>1</sub> (535 mm) is based on ETS 300 119-3 [3], which represents the mounting aperture width in miscellaneous racks and cabinets to accommodate subracks according to ETS 300 119-4 [4].

D (mm) (see note 1)	<b>400</b>	<b>700</b>	1000	1300
D <sub>1</sub> (mm) (see note 2)	300	600	900	1200

The minimum value for D<sub>1</sub> (300 mm) is based on the outside depth of a miscellaneous rack according to ETS 300 119-4 [4].

NOTE 1: Values may be decreased in steps of 25 mm, but this shall not be made a requirement.

NOTE 2: Values may be increased in steps of 25 mm, but this shall not be made a requirement.

## Annex A (informative): Illustrative figures

The outdoor enclosure does not have to conform with the figures illustrated; only the dimensions specified have to be applied.

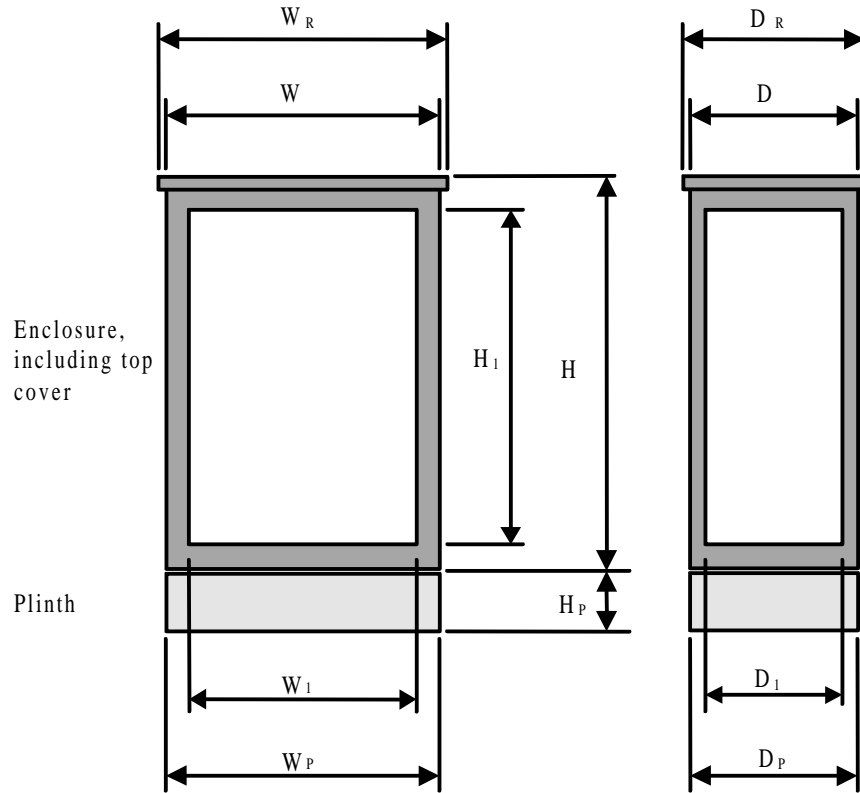

(third angle view)

**Figure A.1: Co-ordination dimensions of unequipped outdoor enclosures / basic views**

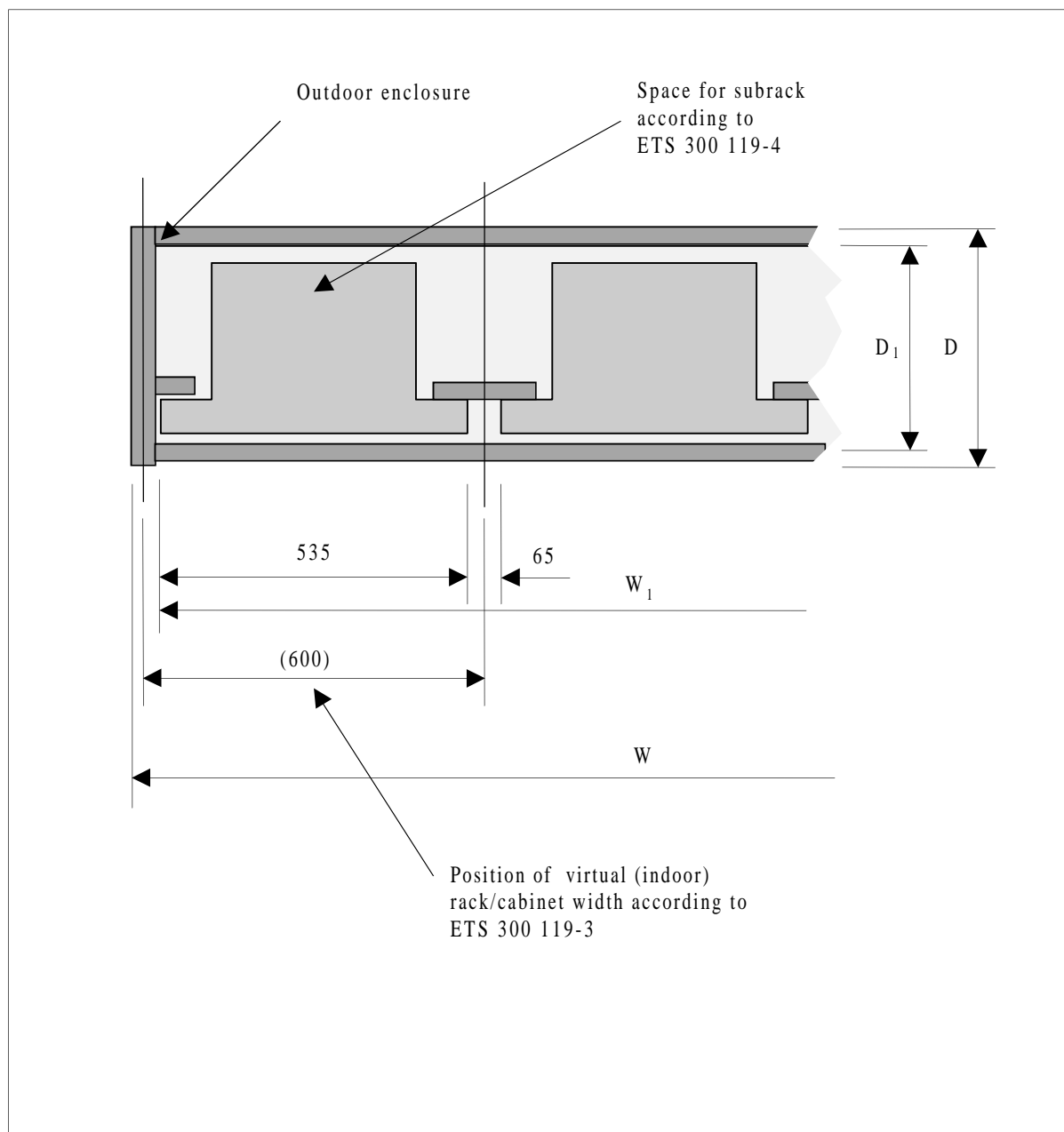

Figure A.2: Co-ordination dimensions for unequipped outdoor enclosures / subrack deployment

---

## Bibliography

The following material, though not specifically referenced in the body of the present document (or not publicly available), gives supporting information.

EN 60439-6 (1995): "Low-Voltage Switchgear and Controlgear Assemblies; Part 6: General Requirements for Empty Enclosures".

## History

<b>Document history</b>				
V1.4.4	March 1998	Public Enquiry	PE 9829:	1998-03-20 to 1998-07-17
V1.5.2	December 1998	Vote	V 9906:	1998-12-08 to 1999-02-05
V1.5.3	February 1999	Publication		