

ETSI EN 301 166-1 V1.3.1 (2008-08)

European Standard (Telecommunications series)

**Electromagnetic compatibility
and Radio spectrum Matters (ERM);
Land Mobile Service;
Radio equipment for analogue and/or digital
communication (speech and/or data) and operating on
narrow band channels and having an antenna connector;
Part 1: Technical characteristics and
methods of measurement**



Reference

REN/ERM-TGDMR-271-1

Keywords

analogue, antenna, connector, data, digital,
mobile, PMR, radio, speech**ETSI**

650 Route des Lucioles
F-06921 Sophia Antipolis Cedex - FRANCE

Tel.: +33 4 92 94 42 00 Fax: +33 4 93 65 47 16

Siret N° 348 623 562 00017 - NAF 742 C
Association à but non lucratif enregistrée à la
Sous-Préfecture de Grasse (06) N° 7803/88

Important notice

Individual copies of the present document can be downloaded from:

<http://www.etsi.org>

The present document may be made available in more than one electronic version or in print. In any case of existing or perceived difference in contents between such versions, the reference version is the Portable Document Format (PDF). In case of dispute, the reference shall be the printing on ETSI printers of the PDF version kept on a specific network drive within ETSI Secretariat.

Users of the present document should be aware that the document may be subject to revision or change of status. Information on the current status of this and other ETSI documents is available at

<http://portal.etsi.org/tb/status/status.asp>

If you find errors in the present document, please send your comment to one of the following services:

http://portal.etsi.org/chaicor/ETSI_support.asp

Copyright Notification

No part may be reproduced except as authorized by written permission.
The copyright and the foregoing restriction extend to reproduction in all media.

© European Telecommunications Standards Institute 2008.
All rights reserved.

DECTTM, **PLUGTESTS**TM, **UMTS**TM, **TIPHON**TM, the TIPHON logo and the ETSI logo are Trade Marks of ETSI registered for the benefit of its Members.

3GPPTM is a Trade Mark of ETSI registered for the benefit of its Members and of the 3GPP Organizational Partners.

Contents

Intellectual Property Rights	7
Foreword.....	7
1 Scope	8
2 References	9
2.1 Normative references	9
2.2 Informative references.....	9
3 Definitions, symbols and abbreviations	10
3.1 Definitions.....	10
3.2 Symbols.....	11
3.3 Abbreviations	12
4 General	12
4.1 Presentation of equipment for testing purposes.....	12
4.1.1 Choice of model for testing	12
4.1.1.1 Auxiliary test equipment	13
4.1.1.2 Declarations by the provider	13
5 Test conditions, power sources and ambient temperatures	13
5.1 Normal and extreme test conditions	13
5.2 Test power source.....	13
5.3 Normal test conditions.....	13
5.3.1 Normal temperature and humidity.....	13
5.3.2 Normal test power source	14
5.3.2.1 Mains voltage.....	14
5.3.2.2 Regulated lead-acid battery power sources used on vehicles.....	14
5.3.2.3 Other power sources.....	14
5.4 Extreme test conditions	14
5.4.1 Extreme temperatures	14
5.4.2 Extreme test source voltages.....	14
5.4.2.1 Mains voltage.....	14
5.4.2.2 Regulated lead-acid battery power sources used on vehicles.....	14
5.4.2.3 Power sources using other types of batteries.....	15
5.4.2.4 Other power sources.....	15
5.5 Procedure for tests at extreme temperatures.....	15
5.5.1 Procedure for equipment designed for continuous transmission.....	15
5.5.2 Procedure for equipment designed for intermittent transmission	15
5.6 Testing of equipment that does not have an external 50 Ω RF connector (integral antenna equipment)	16
6 General test conditions	16
6.1 Test signals.....	16
6.1.1 Transmitter test signals	16
6.1.1.1 Analogue signals (B1).....	16
6.1.1.2 Digital signals (M5, M7).....	16
6.1.2 Receiver test signal for analogue equipment	17
6.1.3 Receiver test signals for data (and digitized voice) equipment (M2), (M3), (M4) and (M6)	17
6.1.4 Transmitter effective radiated power test signal (C1).....	17
6.2 Test load (artificial antenna).....	17
6.3 PEP.....	17
6.4 Encoders.....	17
6.5 Modulation processing	18
6.6 Test sites and general arrangements for radiated measurements	18
6.7 Transmitter automatic shut-off facility.....	18
6.8 Arrangement for analogue test signals at the input of the transmitter	18
6.9 Arrangement for test signals at the input of the receiver.....	18
6.10 Receiver mute or squelch facility	18
6.11 Receiver rated audio output power.....	18

6.12	Facilities for access	18
6.12.1	Analogue access.....	18
6.12.2	Test points for bit stream measurements.....	19
6.12.3	Coupling arrangements	19
6.12.3.1	Arrangements for measurements with continuous bit streams.....	19
6.12.3.2	Arrangements for measurements with messages.....	19
6.12.4	Modes of operation of the transmitter.....	19
6.13	Duplex equipment	19
7	Technical characteristics of the transmitter.....	20
7.1	Maximum power (PX) (conducted).....	20
7.1.1	Definition.....	20
7.1.2	Method of measurement	20
7.1.3	Limit	20
7.2	Maximum effective radiated power.....	20
7.2.1	Definition.....	20
7.2.2	Method of measurement	20
7.2.2.1	Evaluation of CW-to-PEP correction factor for signal C1	20
7.2.2.2	Measurements on a test site.....	21
7.2.3	Limit	22
7.3	Adjacent and alternate channels power	22
7.3.1	Definition.....	22
7.3.2	Methods of measurement.....	23
7.3.3	Limit	24
7.4	Unwanted emissions in the spurious domain.....	24
7.4.1	Definition.....	24
7.4.2	Method of measurement	25
7.4.2.1	Method of measuring conducted spurious emissions (clause 7.4.1 a) in a specified load	25
7.4.2.2	Method of measuring the effective radiated power with an external antenna connector (clause 7.4.1 b).....	25
7.4.2.3	Method of measuring the effective radiated power with an integral antenna (clause 7.4.1 c)	26
7.4.3	Limits.....	27
7.5	Intermodulation attenuation.....	28
7.5.1	Definition.....	28
7.5.2	Method of measurement	28
7.5.3	Limits.....	29
7.6	Transient power.....	29
7.6.1	Definition.....	29
7.6.2	Method of measurement	29
7.6.2.1	Characteristics of the transient power measuring device	30
7.6.3	Limits.....	30
7.7	Frequency error	30
7.7.1	Definition.....	31
7.7.2	Method of measurement	31
7.7.3	Limits.....	31
8	Technical characteristics of the receiver	32
8.1	Maximum usable sensitivity (analogue, conducted)	32
8.1.1	Definition.....	32
8.1.2	Method of measuring the SINAD ratio.....	32
8.1.3	Limits.....	32
8.2	Maximum usable sensitivity (analogue, field strength).....	33
8.2.1	Definition.....	33
8.2.2	Method of measurement	33
8.2.3	Limits.....	34
8.3	Maximum usable sensitivity (digital, conducted).....	34
8.3.1	Definition.....	34
8.3.2	Methods of measurement.....	34
8.3.2.1	Method of measurement with continuous bit streams.....	34
8.3.2.2	Method of measurement with messages.....	35
8.3.3	Limits.....	35
8.4	Maximum usable sensitivity (digital, field strength).....	36

8.4.1	Definition.....	36
8.4.2	Method of measurement	36
8.4.2.1	Method of measurement with continuous bit streams	36
8.4.2.2	Method of measurement with messages.....	37
8.4.3	Limits.....	39
8.5	Adjacent channel selectivity.....	39
8.5.1	Definition.....	39
8.5.2	Method of measurement	39
8.5.2.1	Method of measurement (analogue).....	39
8.5.2.2	Method of measurement (digital with continuous bit stream).....	40
8.5.2.3	Method of measurement with messages.....	41
8.5.3	Limits.....	42
8.6	Spurious response rejection.....	42
8.6.1	Definition.....	42
8.6.2	Method of measurement	42
8.6.2.1	Introduction to the method of measurement.....	42
8.6.2.2	Method of search over the "limited frequency range".....	43
8.6.2.3	Method of measurement (analogue).....	44
8.6.2.4	Method of measurement (digital with continuous bit streams)	44
8.6.2.5	Method of measurement (digital with messages).....	45
8.6.3	Limits.....	46
8.7	Intermodulation response rejection	46
8.7.1	Definition.....	46
8.7.2	Method of measurement	46
8.7.2.1	Method of measurement (analogue).....	46
8.7.2.2	Method of measurement (digital with continuous bit stream).....	47
8.7.2.3	Method of measurement with messages.....	48
8.7.3	Limit	49
8.8	Blocking or desensitization	49
8.8.1	Definition.....	49
8.8.2	Method of measurement	49
8.8.2.1	Method of measurement (analogue).....	49
8.8.2.2	Method of measurement (digital with continuous bit stream).....	50
8.8.2.3	Method of measurement with messages.....	51
8.8.3	Limit	51
8.9	Spurious radiations	52
8.9.1	Definition.....	52
8.9.2	Methods of measurement.....	52
8.9.2.1	Method of measuring the power level in a specified load (clause 8.9.1 a))	52
8.9.2.2	Method of measuring the effective radiated power (clause 8.9.1 b))	52
8.9.2.3	Method of measuring the effective radiated power (clause 8.9.1 c))	53
8.9.3	Limits.....	54
8.10	Co-channel rejection.....	54
8.10.1	Definition.....	54
8.10.2	Methods of measurement.....	54
8.10.2.1	Method of measurement (analogue).....	54
8.10.2.2	Method of measurement (digital with continuous bit stream).....	55
8.10.2.3	Method of measurement with messages.....	56
8.10.3	Limits.....	57
9	Duplex operation	57
9.1	Receiver desensitization (with simultaneous transmission and reception).....	57
9.1.1	Definition.....	57
9.1.2	Methods of measurement.....	58
9.1.2.1	Desensitization measured with analogue modulation	58
9.1.2.1.1	Method of measurement when the equipment has a duplex filter	58
9.1.2.1.2	Method of measurement when the equipment has to operate with two antennas	59
9.1.2.2	Desensitization measured with continuous bit streams	60
9.1.2.2.1	Method of measurement when the equipment has a duplex filter	60
9.1.2.2.2	Method of measurement when the equipment has to operate with two antennas	61
9.1.2.3	Desensitization measured with messages.....	62
9.1.2.3.1	Method of measurement when the equipment has a duplex filter	62

9.1.2.3.2	Method of measurement when the equipment has to operate with two antennas	63
9.1.3	Limits.....	64
9.2	Receiver spurious response rejection (with simultaneous transmission and reception)	64
9.2.1	Definition.....	64
9.2.2	Method of measurement	64
9.2.3	Limits.....	67
10	Measurement uncertainty	68
Annex A (normative): Radiated measurement.....		69
A.1	Test sites and general arrangements for measurements involving the use of radiated fields	69
A.1.1	Anechoic chamber.....	69
A.1.2	Anechoic chamber with a ground plane	70
A.1.3	OATS	71
A.1.4	Test antenna.....	72
A.1.5	Substitution antenna	72
A.1.6	Measuring antenna	73
A.2	Guidance on the use of radiation test sites	73
A.2.1	Verification of the test site	73
A.2.2	Preparation of the EUT.....	73
A.2.3	Power supplies to the EUT	73
A.2.4	Volume control setting for analogue speech tests	73
A.2.5	Range length.....	74
A.2.6	Site preparation	74
A.3	Coupling of signals.....	75
A.3.1	General	75
A.3.2	Data signals	75
A.3.3	Speech and analogue signals	75
A.3.3.1	Acoustic coupler description.....	75
A.3.3.2	Calibration	76
Annex B (normative): Spectrum analyser specification		77
Annex C (normative): Specification for measurement filter		78
Annex D (informative): Bibliography		80
History		81

Intellectual Property Rights

IPRs essential or potentially essential to the present document may have been declared to ETSI. The information pertaining to these essential IPRs, if any, is publicly available for **ETSI members and non-members**, and can be found in ETSI SR 000 314: "*Intellectual Property Rights (IPRs); Essential, or potentially Essential, IPRs notified to ETSI in respect of ETSI standards*", which is available from the ETSI Secretariat. Latest updates are available on the ETSI Web server (<http://webapp.etsi.org/IPR/home.asp>).

Pursuant to the ETSI IPR Policy, no investigation, including IPR searches, has been carried out by ETSI. No guarantee can be given as to the existence of other IPRs not referenced in ETSI SR 000 314 (or the updates on the ETSI Web server) which are, or may be, or may become, essential to the present document.

Foreword

This European Standard (Telecommunications series) has been produced by ETSI Technical Committee Electromagnetic compatibility and Radio spectrum Matters (ERM).

The present document is part 1 of a multi-part deliverable covering Land Mobile Service; Radio equipment for analogue and/or digital communication (speech and/or data) and operating on narrow band channels and having an antenna connector, as identified below:

Part 1: "Technical characteristics and methods of measurement";

Part 2: "Harmonized EN covering essential requirements of article 3.2 of the R&TTE Directive".

National transposition dates	
Date of adoption of this EN:	15 August 2008
Date of latest announcement of this EN (doa):	30 November 2008
Date of latest publication of new National Standard or endorsement of this EN (dop/e):	31 May 2009
Date of withdrawal of any conflicting National Standard (dow):	31 May 2009

1 Scope

The present document covers the technical requirements for radio transmitters and receivers used in stations in the Private Mobile Radio (PMR) service. It applies to use in the land mobile service, operating on radio frequencies between 30 MHz and 3 GHz, with narrow channel separations (CSP) (less than 10 kHz) and intended for speech and/or data. It is the intention of the present document to cover any Channel Bandwidths (CBW) permitted by National Administrations for such systems, e.g. 6,25 kHz.

Table 1: Radiocommunications service frequency bands

Radiocommunications service frequency bands	
Transmit	30 MHz to 3 000 MHz
Receive	30 MHz to 3 000 MHz

In the present document different requirements are given for the different radio frequency bands, environmental conditions and types of equipment where appropriate.

In the present document, data transmission systems are defined as systems which transmit and/or receive data and/or digitized voice. The equipment comprises a transmitter and associated encoder and modulator and/or a receiver and associated demodulator and decoder.

The present document covers equipment which may use constant envelope or non-constant envelope modulation.

The types of equipment covered by the present document are as follows:

- base station: equipment fitted with antenna connector;
- mobile station: equipment fitted with antenna connector.

Handportable stations:

- a) either fitted with an antenna connector; or
- b) without an external antenna connector but fitted with a permanent internal or a temporary internal 50 Ω RF connector which allows access to the transmitter output and the receiver input.

Handportable station equipment without an external or internal Radio Frequency (RF) connector and without the possibility of having a temporary internal 50 Ω RF connector is not covered by the present document.

2 References

References are either specific (identified by date of publication and/or edition number or version number) or non-specific.

- For a specific reference, subsequent revisions do not apply.
- Non-specific reference may be made only to a complete document or a part thereof and only in the following cases:
 - if it is accepted that it will be possible to use all future changes of the referenced document for the purposes of the referring document;
 - for informative references.

Referenced documents which are not found to be publicly available in the expected location might be found at <http://docbox.etsi.org/Reference>.

For online referenced documents, information sufficient to identify and locate the source shall be provided. Preferably, the primary source of the referenced document should be cited, in order to ensure traceability. Furthermore, the reference should, as far as possible, remain valid for the expected life of the document. The reference shall include the method of access to the referenced document and the full network address, with the same punctuation and use of upper case and lower case letters.

NOTE: While any hyperlinks included in this clause were valid at the time of publication ETSI cannot guarantee their long term validity.

2.1 Normative references

- [1] ANSI C63.5-2004: "American National Standard for Electromagnetic Compatibility-Radiated Emission Measurements in Electromagnetic Interference (EMI) Control-Calibration of Antennas (9 kHz to 40 GHz)".
- [2] ITU-T Recommendation O.153: "Basic parameters for the measurement of error performance at bit rates below the primary rate".
- [3] IEC 60489-3: "Methods of measurement for radio equipment used in the mobile services. Part 3: Receivers for A3E or F3E emissions" Second edition (1988) appendix F.
- [4] ITU-R Recommendation SM.329-10 (2003): "Unwanted emissions in the spurious domain".
- [5] ITU-T Recommendation O.41 (1984): "Psophometer for use on telephone-type circuits".

2.2 Informative references

The following referenced documents are not essential to the use of the ETSI deliverable but they assist the user with regard to a particular subject area. For non-specific references, the latest version of the referenced document (including any amendments) applies.

- [i.1] ETSI TR 100 028 (V1.4.1) (all parts): "Electromagnetic compatibility and Radio spectrum Matters (ERM); Uncertainties in the measurement of mobile radio equipment characteristics; Part 1".
- [i.2] ETSI TR 102 273 (all parts) (V1.2.1): "Electromagnetic compatibility and Radio spectrum Matters (ERM); Improvement on Radiated Methods of Measurement (using test site) and evaluation of the corresponding measurement uncertainties".

3 Definitions, symbols and abbreviations

3.1 Definitions

For the purposes of the present document, the following terms and definitions apply:

50 Ω : 50 ohm non-reactive impedance

adjacent and alternate channels:

- adjacent channels are those two channels offset from the wanted channel by the channel spacing;
- alternate channels are those two channels offset from the wanted channel by double the channel spacing

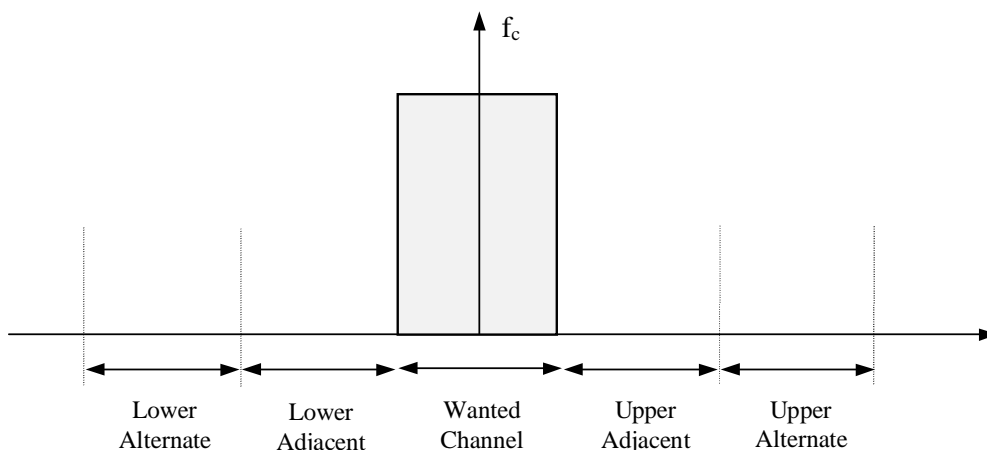

Figure 1: Adjacent and alternate channel definitions

audio frequency input socket: socket normally intended for connection to a microphone for the purpose of voice transmission

NOTE: In some cases, this socket could be expected to be used for the input of an audio sub-carrier, modulated to carry data, such as FFSK.

base station: equipment fitted with an antenna connector, for use with an external antenna and intended for use in a fixed location

bit: binary digit

block: smallest quantity of information that is sent over the radio channel

NOTE: A constant number of useful bits are always sent together with the corresponding redundancy bits.

conducted measurements: measurements which are made using direct 50 Ω connection to the equipment under test

data transmission systems: systems which transmit and/or receive data and/or digitized voice

facilities socket: any socket intended for purposes other than the transmission of voice

NOTE 1: The purpose of the socket and required input signals are specified by the manufacturer.

NOTE 2: The audio frequency input socket and the facilities socket may be the same physical socket in some implementations.

handportable station: equipment either fitted with an antenna connector or an integral antenna, or both, normally used on a stand-alone basis, to be carried on a person or held in the hand

integral antenna: antenna designed to be connected to the equipment without the use of a 50 Ω external connector and considered to be part of the equipment

NOTE: An integral antenna may be fitted internally or externally to the equipment.

Listen Before Transmit mode (LBT): monitoring mode in which the RF channel is checked for activity before transmitting

NOTE: Examples for LBT are transceivers or systems implementing squelch, CTCSS (Continuous Tone Control Squelch System), RSSI (Receiver Signal Strength Indicator), algorithms evaluating the status of the channel.

message: user data to be transferred in one or more packets in a session

mobile station: mobile equipment fitted with an antenna connector, for use with an external antenna, normally used in a vehicle or as a transportable station

necessary bandwidth: for a given class of emission, the width of the frequency band which is just sufficient to ensure the transmission of information at the rate and with the quality required under specified conditions

NOTE: See ITU-R Recommendation SM.329-10 [4].

packet: one block or a contiguous stream of blocks sent by one (logical) transmitter to one particular receiver or one particular group of receivers

radiated measurements: measurements which involve the absolute measurement of a radiated field

session: set of inter-related exchange of packets occupying one or several windows or part thereof (if applicable)

NOTE: A session corresponds to a complete interactive procedure for interchanging data between users, comprising initiation, data transmission and termination procedures. The session can be short (e.g. 2 packets), or long (e.g. one full page of text).

switching range: maximum frequency range, as specified by the manufacturer, over which the receiver or the transmitter can be operated within the alignment range without reprogramming or realignment

transmission (physical): one or several packets transmitted between power on and power off of a particular transmitter

window: set of inter-related transmissions which may be limited in time by an appropriate access protocol and corresponding occupation rules

3.2 Symbols

For the purposes of the present document, the following symbols apply:

AR	Alignment Range
NOTE:	See clause 4.1.
dB	decibel
dBm	dB relative to 1 mW
dB μ V	dB relative to 1 μ V
f_c	Channel centre frequency
f_{I1}	1 st intermediate frequency
f_{I2}	2 nd intermediate frequency
f_{In}	n th intermediate frequency
f_{LO}	Local oscillator frequency
M1, M2, etc.	names of test signals defined in clause 6.1
PR	rms power
PX	Maximum power

V _{min}	Minimum extreme test voltage
V _{max}	Maximum extreme test voltage
T _{min}	Minimum extreme test temperature
T _{max}	Maximum extreme test temperature
λ	wavelength

3.3 Abbreviations

For the purposes of the present document, the following abbreviations apply:

ac	alternating current
Bit	Binary digit
CBW	Channel BandWidth
CSP	Channel SeParation
CTCSS	Continuous Tone Control Squelch System
CW	Continuous Wave
DC	Direct Current
EMC	ElectroMagnetic Compatibility
emf	electromotive force
EUT	Equipment Under Test
FFSK	Fast Frequency Shift Keying
GMSK	Gaussian Minimum Shift Keying
IF	Intermediate Frequency
LBT	Listen Before Transmit
OATS	Open Area Test Site
PEP	Peak Envelope Power
PMR	Professional Mobile Radio
RF	Radio Frequency
rms	root mean square
RSSI	Receiver Signal Strength Indicator
SINAD	(signal + noise + distortion)/(noise + distortion)
sr	switching range
Tx	Transmitter
VSWR	Voltage Standing Wave Ratio

4 General

4.1 Presentation of equipment for testing purposes

Each equipment to be tested submitted for testing shall fulfil the requirements of the present document on all frequencies over which it is intended to operate.

The provider or manufacturer shall declare the frequency ranges, the range of operating conditions and power requirements as applicable, to establish the appropriate test conditions.

Additionally, technical documentation and operating manuals, sufficient to make the test, shall be supplied.

4.1.1 Choice of model for testing

The provider or manufacturer shall provide one or more samples of the equipment, as appropriate for testing.

Stand alone equipment shall be complete with any ancillary equipment needed for testing.

If an equipment has several optional features, considered not to affect the RF parameters then the tests need only to be performed on the equipment configured with that combination of features considered to be the most complex.

Where practicable, equipment to be tested shall provide a 50 Ω connector for conducted RF power level measurements.

In the case of integral antenna equipment, if the equipment does not have a internal permanent 50 Ω connector then it is permissible to supply a second sample of the equipment with a temporary antenna connector fitted to facilitate testing.

The performance of the equipment to be tested shall be representative of the performance of the corresponding production model.

4.1.1.1 Auxiliary test equipment

All necessary test signal sources, setting up instructions and other product information shall accompany the equipment to be tested.

4.1.1.2 Declarations by the provider

The provider or manufacturer shall declare the necessary information of the equipment with respect to all technical requirements set by the present document.

In the case of hand portable equipment without a 50 Ω external antenna connector see clause 5.6.

5 Test conditions, power sources and ambient temperatures

5.1 Normal and extreme test conditions

Testing shall be performed under normal test conditions, and also, where stated, under extreme test conditions.

The test conditions and procedures shall be as specified in clauses 5.2 to 5.5.

5.2 Test power source

During testing the power source of the equipment shall be replaced by a test power source capable of producing normal and extreme test voltages as specified in clauses 5.3.2 and 5.4.2. The internal impedance of the test power source shall be low enough for its effect on the test results to be negligible. For the purpose of tests, the voltage of the power source shall be measured at the input terminals of the equipment.

For battery operated equipment the battery shall be removed and the test power source shall be applied as close to the battery terminals as practicable.

During tests of DC powered equipment the power source voltages shall be maintained within a tolerance of $< \pm 1$ % relative to the voltage at the beginning of each test. The value of this tolerance is critical for power measurements, using a smaller tolerance will provide better measurement uncertainty values.

5.3 Normal test conditions

5.3.1 Normal temperature and humidity

The normal temperature and humidity conditions for tests shall be any convenient combination of temperature and humidity within the following ranges:

- temperature: +15 $^{\circ}\text{C}$ to +35 $^{\circ}\text{C}$;
- relative humidity: 20 % to 75 %.

When it is impracticable to carry out the tests under these conditions, a note to this effect, stating the ambient temperature and relative humidity during the tests, shall be added to the test report.

5.3.2 Normal test power source

5.3.2.1 Mains voltage

The normal test voltage for equipment to be connected to the mains shall be the nominal mains voltage. For the purpose of the present document, the nominal voltage shall be the declared voltage or any of the declared voltages for which the equipment was designed.

The frequency of the test power source corresponding to the ac mains shall be between 49 Hz and 51 Hz.

5.3.2.2 Regulated lead-acid battery power sources used on vehicles

When the radio equipment is intended for operation from the usual types of regulated lead-acid battery power source used on vehicles the normal test voltage shall be 1,1 times the nominal voltage of the battery (for nominal voltages of 6 V and 12 V, these are 6,6 V and 13,2 V respectively).

5.3.2.3 Other power sources

For operation from other power sources or types of battery (primary or secondary), the normal test voltage shall be that declared by the equipment manufacturer.

5.4 Extreme test conditions

5.4.1 Extreme temperatures

For tests at extreme temperatures, measurements shall be made in accordance with the procedures specified in clause 5.5, at the upper and lower temperatures of one of the following two ranges:

- -20 °C to +55 °C;
All mobile and handportable equipment.
Base stations for outdoor/uncontrolled climate conditions.
- 0 °C to +40 °C;
Base stations for indoor/controlled climate conditions.

In the case of base stations equipment, the manufacturer shall declare which conditions the equipment is intended to be installed in.

5.4.2 Extreme test source voltages

5.4.2.1 Mains voltage

The extreme test voltage for equipment to be connected to an ac mains source shall be the nominal mains voltage $\pm 10\%$.

5.4.2.2 Regulated lead-acid battery power sources used on vehicles

When the equipment is intended for operation from the usual types of regulated lead-acid battery power sources used on vehicles the extreme test voltages shall be 1,3 and 0,9 times the nominal voltage of the battery (for a nominal voltage of 6 V, these are 7,8 V and 5,4 V respectively and for a nominal voltage of 12 V, these are 15,6 V and 10,8 V respectively).

5.4.2.3 Power sources using other types of batteries

The lower extreme test voltages for equipment with power sources using batteries shall be as follows:

- for the nickel metal-hydrate, leclanché or lithium type: 0,85 times the nominal battery voltage;
- for the mercury or nickel-cadmium type: 0,9 times the nominal battery voltage.

No upper extreme test voltages apply.

In the case where no upper extreme test voltage the nominal voltage is applicable, the corresponding four extreme test conditions are:

- V_{\min}/T_{\min} , V_{\min}/T_{\max} ;
- $(V_{\max} = \text{nominal})/T_{\min}$, $(V_{\max} = \text{nominal})/T_{\max}$.

5.4.2.4 Other power sources

For equipment using other power sources, or capable of being operated from a variety of power sources, the extreme test voltages shall be those declared by the equipment manufacturer.

5.5 Procedure for tests at extreme temperatures

Before measurements are made the equipment shall have reached thermal balance in the test chamber. The equipment shall be switched off during the temperature stabilizing period.

In the case of equipment containing temperature stabilization circuits designed to operate continuously, the temperature stabilization circuits may be switched on for 15 minutes after thermal balance has been obtained, and the equipment shall then meet the specified requirements. For such equipment the manufacturer shall provide for the power source circuit feeding the crystal oven to be independent of the power source for the rest of the equipment.

If the thermal balance is not checked by measurements, a temperature stabilizing period of at least one hour, or a longer period as may be decided by the testing laboratory, shall be allowed. The sequence of measurements shall be chosen, and the humidity content in the test chamber shall be controlled so that excessive condensation does not occur.

5.5.1 Procedure for equipment designed for continuous transmission

If the manufacturer states that the equipment is designed for continuous transmission, the test procedure shall be as follows.

Before tests at the upper extreme temperature, the equipment shall be placed in the test chamber, and left until thermal balance is attained. The equipment shall then be switched on in the transmit condition for a period of half an hour, after which the equipment shall meet the specified requirements.

Before tests at the lower extreme temperature, the equipment shall be left in the test chamber until thermal balance is attained, then switched to the standby or receive condition for a period of one minute, after which the equipment shall meet the specified requirements.

5.5.2 Procedure for equipment designed for intermittent transmission

If the manufacturer states that the equipment is designed for intermittent transmission, the test procedure shall be as follows.

Before tests at the upper extreme temperature, the equipment shall be placed in the test chamber, and left until thermal balance is attained. The equipment shall then be switched on for one minute in the transmit condition, followed by four minutes in the receive condition, after which the equipment shall meet the specified requirements.

For tests at the lower extreme temperature, the equipment shall be left in the test chamber until thermal balance is attained, then switched to the standby or receive condition for one minute, after which the equipment shall meet the specified requirements.

5.6 Testing of equipment that does not have an external 50 Ω RF connector (integral antenna equipment)

Where equipment has an internal 50 Ω connector it shall be permitted to perform the tests at this connector.

Equipment may also have a temporary internal 50 Ω connector installed for the purposes of testing.

No connection shall be made to any internal permanent or temporary antenna connector during the performance of radiated emissions measurements, unless such action forms an essential part of the normal intended operation of the equipment, as declared by the manufacturer.

6 General test conditions

6.1 Test signals

6.1.1 Transmitter test signals

The manufacturer shall declare details of the modulation scheme used and identify how the percentage modulation can be measured or specified.

Equipment capable of transmission of digital information shall be tested with modulation M5. Equipment using analogue transmission shall be tested with modulation B1. Equipment capable of both analogue and digital transmission shall be tested separately in each mode with B1 and M5 modulation respectively.

6.1.1.1 Analogue signals (B1)

For tests on analogue equipment via the audio input socket terminals, the test signal B1 shall consist of two equal amplitude non harmonically related sinusoidal input signals selected to be in the range 500 Hz to 3 kHz with at least 500 Hz separation between them, each of which would independently drive the transmitter into its compression region. The composite signal level shall be 20 dB higher than the level which produces 60 % modulation unless the output power at this drive level is less than the highest Tx output power in which case the signal level shall be set to produce the highest possible Tx output power.

For tests via any facilities sockets, test signal B1 shall be of the nature described by the manufacturer for the purpose of the socket, at a level which produces the largest value of output power (PEP) possible with analogue modulation. The resulting RF spectrum should be equivalent to that of B1 applied to the audio input terminals.

6.1.1.2 Digital signals (M5, M7)

For tests on digital equipment (including digital speech), test signal M5 shall consist of a pseudo-random bit sequence of at least 511 bits (according to ITU-T Recommendation O.153 [2]), at the appropriate data rate.

If the transmission of a continuous bit stream is not possible, test signal M7 shall be trains of correctly coded bits or messages. An encoder as defined in clause 6.4 may be used.

For the purpose of testing PX in clause 7.1 test signals M5 and M7 should produce the largest value of output power (PEP) possible with digital modulation. If this is not the case then a test signal that does produce the largest possible value of output power (PEP) with digital modulation should be used in the testing in clause 7.1.

For digital equipments that support adaptive rates, testing is only required at one bit rate. For transmitter tests in this clause this would normally be the highest bit-rate supported by the equipment.

Manufacturers shall declare where any of the specific tests in clause 7, if conducted at rates other than the highest bit rate, are likely to give results which are worse than at the highest bit rate. In such cases the tests will be carried out at the rate declared by the manufacturer that is likely to give the worst performance (least margin between measured results and test limits).

6.1.2 Receiver test signal for analogue equipment

The test signal shall be such that it represents the output from the transmitter and provides the necessary input for correct operation of the receiver. The test signal used shall be such as to produce a 1 kHz tone at the output of the receiver. Details of the test signal used shall be recorded.

6.1.3 Receiver test signals for data (and digitized voice) equipment (M2), (M3), (M4) and (M6)

When the equipment is designed to transmit continuous bit streams (e.g. data, facsimile, image transmission, digitized voice) the normal test signal shall be generated using a method as declared by the equipment manufacturer and shall be as follows:

Signal M2, consisting of a RF carrying a pseudo-random bit sequence of at least 511 bits (according to ITU-T Recommendation O.153 [2]).

If the transmission of a continuous bit stream is not possible, test signal M6 shall be trains of correctly coded bits or messages. An encoder as defined in clause 6.4 may be used.

Signal M3, consisting of a RF signal, modulated in frequency by an audio frequency signal of 1 kHz with a resulting deviation of 12 % of the CSP.

Signal M4, consisting of a RF signal, modulated in frequency by an audio frequency signal of 0,4 kHz with a resulting deviation of 12 % of the CSP. This signal is used as an unwanted signal.

6.1.4 Transmitter effective radiated power test signal (C1)

Test signal C1 shall be any signal that provides a constant envelope of output power at the output of the transmitter. This may be a CW tone or a modulated signal with constant envelope (e.g. GMSK). The envelope shall be flat to ± 1 dB.

If the equipment under test is capable of operating in non-constant envelope modes, or at higher powers than with test signal C1, the ratio, in dB, between the mean power obtained with test signal C1 and the maximum PEP for any modulating signal accepted by the transmitter shall be known as the CW-to-PEP correction factor for signal C1.

6.2 Test load (artificial antenna)

For conducted measurements of the transmitter, a power attenuator ("artificial antenna") shall be used, exhibiting a substantially non-reactive, non-radiating load of 50 Ω to the antenna connector and capable of dissipating the transmitter output power.

6.3 PEP

The PEP is the average power supplied to the artificial antenna by a transmitter during one RF cycle at the highest crest of the modulation envelope. For practical purposes the methods of measurements in clause 7.1.2 should be used.

6.4 Encoders

The encoder will be used to generate the test signal using a method as declared by the equipment manufacturer.

Where necessary details of all codes and code format(s) used shall be given.

In the case of equipment unable to operate with continuous bit streams, the encoder shall be capable of operation in a repetitive mode. For transmitter measurements the operation of the encoder shall enable continuous modulation for the duration of the measurements. For receiver measurements the operation of the encoder shall provide intervals between each message that are not less than the reset time of the receiver.

6.5 Modulation processing

Any modulation processing, if included in the transmitter, shall be operative unless otherwise specified.

6.6 Test sites and general arrangements for radiated measurements

For guidance on radiation test sites see annex A. Detailed descriptions of the radiated measurement arrangements are included in this annex.

6.7 Transmitter automatic shut-off facility

If the equipment is fitted with an automatic transmitter shut-off facility it shall be made inoperative for the duration of the type test, unless it has to be left operative to protect the equipment.

6.8 Arrangement for analogue test signals at the input of the transmitter

For the purpose of the present document, in the case of analogue equipment, the transmitter audio frequency modulation signal shall be applied to the terminals of the audio input connector with any microphone disconnected, unless otherwise stated.

6.9 Arrangement for test signals at the input of the receiver

RF test signal sources which are applied to the receiver shall present an impedance of 50 Ω to the receiver input. This requirement shall be met irrespective of whether one or more signals using a combining network are applied to the receiver simultaneously.

The levels of the test signals shall be expressed in terms of the emf at the receiver input connector.

The effects of any intermodulation products and noise produced in the test signal sources shall be negligible.

6.10 Receiver mute or squelch facility

If the receiver is equipped with a mute or squelch circuit, this shall be made inoperative for the duration of the tests.

6.11 Receiver rated audio output power

The rated audio output power shall be the maximum power, declared by the manufacturer, for which all the requirements of the present document are met. With receiver test signal (see clause 6.1.2), the audio output power shall be measured in a resistive load simulating the load with which the receiver normally operates. The impedance of this load shall be declared by the manufacturer.

6.12 Facilities for access

6.12.1 Analogue access

In order to simplify the measurements in clauses 8.2 and 8.6, a temporary access to a point where the amplitude of the analogue output of the RF part can be measured should be provided, e.g. an IF output or the demodulated subcarrier point. This access can be used to determine or verify the frequency where a spurious response is expected.

6.12.2 Test points for bit stream measurements

It is recognized that it is not always possible to measure the air interface bit stream. The manufacturer shall define the test points at which the equipment shall be tested in order to make the measurements on bit streams in clauses 7, 8 and 9.

Figure 2 is presented as an example for clarification only.

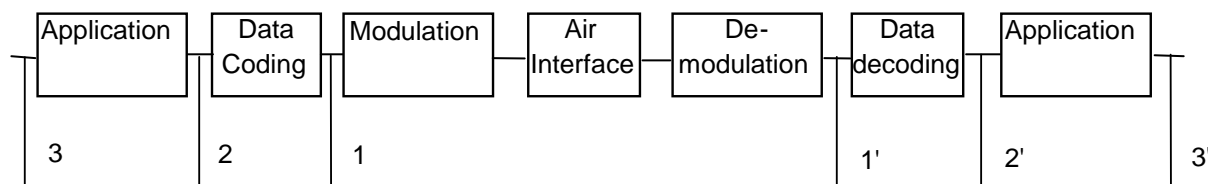

Figure 2: Test points for bit stream measurements

It should be noted that the closer the test access point is located to the air interface (see figure 2), a smaller number of variants may have to be type tested because the measurement is less application dependent.

The tests shall be performed by use of corresponding test points (1,1' or 2,2' or 3,3').

6.12.3 Coupling arrangements

If the equipment does not have an external antenna connection, arrangements shall be made by the manufacturer to couple the unit to be tested to the test equipment by a method which does not affect the radiated field (e.g. acoustic, ultrasonic or optical) and according to the clauses 6.12.3.1 and 6.12.3.2.

6.12.3.1 Arrangements for measurements with continuous bit streams

For the measurements of the receiver on a test site, arrangements to couple the unit to be tested to the error observation device shall be available (see clause 6.12.2).

Furthermore, another facility to give access to the analogue information (see clause 6.12.1) can also be provided.

6.12.3.2 Arrangements for measurements with messages

For the measurement of the receiver on a test site, arrangements to couple the unit to be tested to the error observation device (or to an operator) shall be available.

Furthermore, another facility to give access to the analogue information (see clause 6.12.1) can also be provided.

6.12.4 Modes of operation of the transmitter

For the purpose of the measurements according to the present document there should preferably be a facility to operate the transmitter unmodulated. The method of obtaining an unmodulated carrier or special types of modulation patterns may be decided by the manufacturer. It may involve suitable temporary internal modifications of the equipment under test.

6.13 Duplex equipment

If the equipment is provided with a built in duplex filter or a separate associated filter, the requirements of the present document shall be met when the measurements are carried out using the antenna connector of the filter.

Duplex measurements shall be carried out on a single pair of frequencies only, as specified by the manufacturer.

Duplex equipment having integral antenna may be tested using the internal or temporary antenna connector.

7 Technical characteristics of the transmitter

7.1 Maximum power (PX) (conducted)

This measurement applies only to equipment with an external 50 Ω antenna connector.

NOTE: PEP measurement is used as a figure of merit; however, it is accepted that for digital modulation the average power is often a more useful parameter.

7.1.1 Definition

The PX of the transmitter is the maximum value of the output PEP for any condition of modulation.

The rated maximum power of the transmitter is that declared by the manufacturer.

7.1.2 Method of measurement

For non-constant envelope modulation test signal B1, M5 or M7 (as appropriate, see clause 6.1.1) shall be applied at the transmitter. For constant envelope modulation schemes it is not required to apply modulation. The modulation used, if any, shall be recorded in the test report.

The transmitter shall be connected to a 50 Ω power attenuator, and the PEP delivered shall be measured. The measuring instrument shall have a measurement bandwidth not less than sixteen times the CBW.

The power measured is recorded as the value PX.

The measurement shall be made under normal test conditions (see clause 5.3) and repeated under extreme test conditions (see clauses 5.4.1 and 5.4.2 applied simultaneously).

7.1.3 Limit

The measured PX under normal test conditions shall be within $\pm 1,5$ dB of the rated maximum power of the transmitter.

The measured PX under extreme test conditions shall be within +2 dB and -3 dB of the rated maximum power of the transmitter.

It is assumed that the appropriate National Administration will state the maximum permitted transmitter output power.

7.2 Maximum effective radiated power

7.2.1 Definition

The maximum effective radiated power of the transmitter is the maximum value of the output PEP for any condition of modulation radiated in the direction of the maximum field strength by the equipment with its integral antenna fitted. The rated maximum effective radiated power is that declared by the manufacturer.

7.2.2 Method of measurement

This measurement method applies only for equipment without an external 50 Ω antenna connector.

7.2.2.1 Evaluation of CW-to-PEP correction factor for signal C1

The measurement shall be carried out under normal conditions only.

The transmitter permanent internal or a temporary internal 50 Ω RF connector shall be connected to a 50 Ω power attenuator. The transmitter shall be switched on with test signal C1 (see clause 6.1.4) applied and the PEP delivered shall be measured. The measuring instrument shall have a measurement bandwidth not less than sixteen times the CBW.

The mean power delivered shall also be measured. The difference between the PEP and the mean power shall be less than 1 dB.

Modulation test signal B1, M5 or M7 (as appropriate, see clause 6.1.1) shall then be applied at the transmitter. The PEP delivered to its artificial antenna shall be measured.

The difference (in dB) between the PEP measured for B1, M5 or M7 modulation and the mean power measured for C1 modulation shall be recorded. This value is the CW-to-PEP correction factor for signal C1.

7.2.2.2 Measurements on a test site

The measurement shall be carried out under normal conditions only.

On a test site, selected from annex A, the equipment and its antenna shall be mounted in a normal installation in its normal operating position, shall be placed at the specified height on a non-conducting support, in the position closest to normal use as declared by the manufacturer. This position shall be recorded in the test report.

The test antenna shall be orientated for vertical polarization and the length of the test antenna shall be chosen to correspond to the frequency of the transmitter.

The output of the test antenna shall be connected to a measuring receiver.

The transmitter shall be switched on with test signal C1 (see clause 6.1.4) applied and the measuring receiver shall be tuned to the centre frequency of the channel on which the transmitter is intended to operate.

The test antenna shall be raised and lowered through the specified range of height until a maximum signal level is detected on the measuring receiver.

When a test site according to clause A.1.1 is used there is no need to vary the height of the antenna.

The transmitter shall then be rotated through 360 ° in the horizontal plane until the maximum signal level is detected by the measuring receiver.

The maximum signal level detected by the measuring receiver shall be noted.

The transmitter shall be replaced by a substitution antenna as defined in clause A.1.5.

The substitution antenna shall be orientated for vertical polarization and the length of the substitution antenna shall be adjusted to correspond to the frequency of the transmitter.

The substitution antenna shall be connected to a calibrated signal generator.

The sensitivity of the measuring receiver shall be increased in accordance with the new input level (change in attenuator setting).

The test antenna shall be raised and lowered through the specified range of height to ensure that the maximum signal is received. When a test site according to clause A.1.1 is used there is no need to vary the height of the antenna.

The input signal to the substitution antenna shall be adjusted to a level that produces the level detected by the measuring receiver, that is equal to the level noted while using the transmitter under test, corrected for the change in the attenuator setting in the measuring receiver.

The input level to the substitution antenna shall be recorded as a power level.

The measurement shall be repeated with the test antenna and the substitution antenna orientated for horizontal polarization.

The measure of the maximum effective radiated power is the larger of the two power levels recorded at the input to the substitution antenna, corrected for the gain of the antenna if necessary.

The maximum effective radiated PEP is the effective radiated power corrected by the CW-to-PEP correction factor for signal C1, as measured in clause 7.2.2.1.

7.2.3 Limit

The maximum effective radiated power under normal test conditions shall be within d_f from the rated effective radiated power.

The allowance for the characteristics of the equipment ($\pm 1,5$ dB) shall be combined with the actual measurement uncertainty in order to provide d_f , as follows:

$$- \quad d_f^2 = d_m^2 + d_e^2;$$

where:

- d_m is the actual measurement uncertainty;
- d_e is the allowance for the equipment (1,5 dB);
- d_f is the final difference.

All values shall be expressed in linear terms.

In all cases the actual measurement uncertainty shall comply with clause 10.

Furthermore, the maximum effective radiated power shall not exceed the maximum value allowed by the administrations.

Example of the calculation of d_f :

- $d_m = 6$ dB (value acceptable, as indicated in the table of maximum uncertainties);
- $= 3,98$ in linear terms;
- $d_e = 1,5$ dB (fixed value for all equipment fulfilling the requirements of the present document);
- $= 1,41$ in linear terms;
- $d_f^2 = (3,98)^2 + (1,41)^2$; therefore;
- $d_f = 4,22$ in linear terms, or 6,25 dB.

This calculation shows that in this case d_f is in excess by 0,25 dB compared to d_m , the actual measurement uncertainty (6 dB).

7.3 Adjacent and alternate channels power

7.3.1 Definition

The adjacent channel power is that part of the total output power of a transmitter, under defined conditions of modulation, which falls within specified passbands centred on the nominal frequency of either of the adjacent channels.

The alternate channel power is that part of the total output power of a transmitter, under defined conditions of modulation, which falls within specified passbands centred on the nominal frequency of either of the alternate channels.

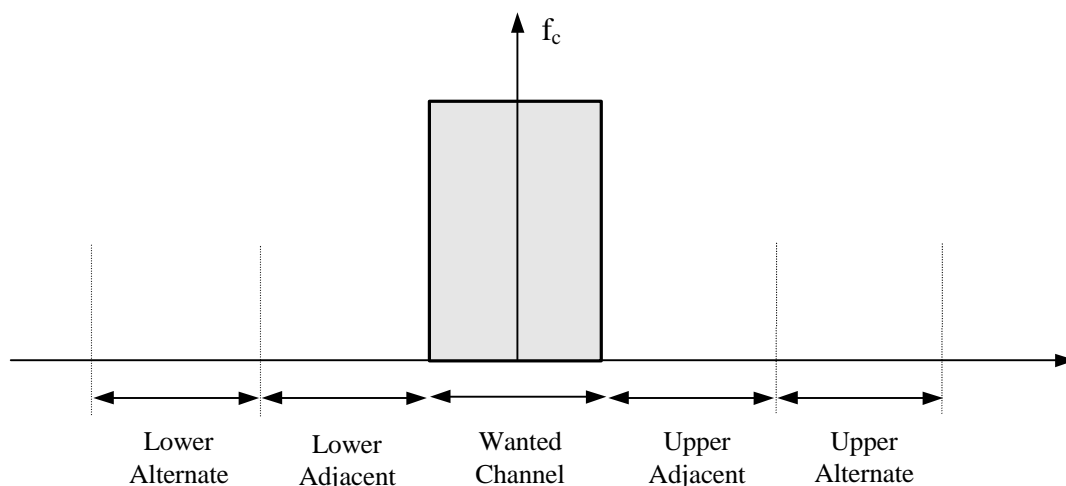

Figure 3: Adjacent and alternate channel definitions

These powers are the sum of the rms powers produced by the modulation, hum and noise of the transmitter.

7.3.2 Methods of measurement

The adjacent and alternate channel powers shall be measured with a spectrum analyser which conforms with the requirements given in annex B.

The transmitter shall be operated at the power determined in clauses 7.1.2 or 7.2.2 as appropriate, under normal test conditions, see clause 5.3.

The transmitter shall be modulated with test signal B1, M5 or M7 (as appropriate, see clause 6.1.1). The modulation used shall be recorded in the test report.

The output of the transmitter shall be connected to the input of the spectrum analyser by a 50 Ω power attenuator, to ensure that the impedance presented to the transmitter is 50 Ω and the level at the spectrum analyser input is appropriate.

The resolution bandwidth of the spectrum analyser shall be 100 Hz.

The rms power present in the nominal channel, measured on the spectrum analyser, shall be recorded (the wanted channel power, PR).

For the purpose of the remainder of this test the CBW shall be $0,7 \times \text{CSP}$. The CBW shall be centred one CSP above the centre of the nominal channel. The rms power present in the CBW shall be recorded (the adjacent channel power).

The measurement shall be repeated with the CBW centred one CSP below the centre of the nominal channel.

The measurement shall be made under normal test conditions (see clause 5.3) and repeated under extreme test conditions (see clauses 5.4.1 and 5.4.2 applied simultaneously).

Measurement under extreme conditions (see clause 5.4) may be omitted if the equipment is capable of testing for frequency error and such tests are carried out under clause 7.7.

The adjacent channel power ratio is the difference (in dB) between the measured wanted channel power (PR) under normal test conditions and the largest adjacent channel power.

Alternatively, if the spectrum analyser measures rms adjacent channel power automatically, the adjacent channel power (in dB) may be measured directly at normal and extreme test conditions. The analyser should use an analogue measurement method without frequency weighting and not using an accelerated method. The adjacent channel power ratio is the smaller of the measurement results under normal and extreme conditions.

The measurement shall be repeated with the CBW centred two CSP above the centre of the nominal channel. The measurement shall be repeated with the CBW centred two CSP below the centre of the nominal channel. The measurement shall be made under normal test conditions (see clause 5.3) and repeated under extreme test conditions (see clauses 5.4.1 and 5.4.2 applied simultaneously). Automatic measurement may also be used if supported by the spectrum analyser.

Measurement under extreme conditions (see clause 5.4) may be omitted if the equipment is capable of testing for frequency error and such tests are carried out under clause 7.7.

The alternate channel power ratio is the difference (in dB) between the measured integrated wanted channel power under normal test conditions and the largest alternate channel power.

7.3.3 Limit

The rms power in each adjacent channel shall not exceed a value of 60 dB below the rms power in the wanted channel (PR), measured under normal test conditions, see clause 5.3. The rms power in each adjacent channel shall not exceed a value of 55 dB below the rms power in the wanted channel (PR), measured under extreme test conditions, clause 5.4, without the need to be below 0,2 μ W (-37 dBm), under both normal and extreme conditions.

The rms power in each alternate channel, centred two CSP from the nominal channel centre, shall not exceed a value of 70 dB below the rms power (PR) measured under normal test conditions, clause 5.3. The power in each alternate channel, centred two CSP from the nominal channel centre, shall not exceed a value of 65 dB below the rms power (PR), measured under extreme test conditions, see clause 5.4, without the need to be below 0,2 μ W (-37 dBm), under both normal and extreme conditions.

Limits under extreme conditions (see clause 5.4) are not applicable if the equipment is capable of being tested for frequency error and such tests are carried out under clause 7.7.

7.4 Unwanted emissions in the spurious domain

7.4.1 Definition

Spurious emissions are emissions on a frequency, or frequencies, which are outside the necessary bandwidth and the level of which may be reduced without affecting the corresponding transmission of information. Spurious emissions include harmonic emissions, parasitic emissions, intermodulation products and frequency conversion products but exclude out of band emissions. For the purpose of the present document the transition point between spurious emissions domain and the out of band emissions domain is taken as 250 % of the CSP (see ITU-R Recommendation SM.329-10 [4]).

For equipment with an external 50 Ω antenna connector, the level of spurious emissions are considered to be either:

- a) their power level in a specified load (conducted spurious emission); and
- b) their effective radiated power when radiated by the cabinet and structure of the equipment (cabinet radiation).

For equipment without an external antenna connector, spurious radiations are considered to be:

- c) their effective radiated power when radiated by the cabinet and the integral antenna, in the case of handportable equipment fitted with such an antenna and no external RF connector.

7.4.2 Method of measurement

7.4.2.1 Method of measuring conducted spurious emissions (clause 7.4.1 a)) in a specified load

This method applies only to equipment with an external 50 Ω antenna connector.

Spurious emissions shall be measured as the mean power level of any signal delivered into a 50 Ω load. This may be done by connecting the transmitter output through an attenuator to either a spectrum analyser (see also annex B) or selective voltmeter or by monitoring the relative levels of the spurious signals delivered to an artificial antenna (see clause 6.2).

The transmitter shall be modulated with test signal C1 and the measurements made over the frequency range 30 MHz to 4 GHz.

For equipment operating on frequencies above 470 MHz the measurements shall also be performed over the frequency range 4 GHz to 12,75 GHz if emissions are detected within 10 dB of the of the specified limit between 1,5 GHz and 4 GHz.

The measurements are performed excluding the five contiguous channels centred on the channel on which the transmitter is intended to operate.

The measurement shall be repeated with the transmitter modulated by the test signal B1, M5 or M7 (as appropriate, see clause 6.1.1). If possible, the modulation should be continuous for the duration of the measurement.

As a general rule, the resolution bandwidth of the measuring receiver should be equal to the reference bandwidth as given in clause 7.4.3. To improve measurement accuracy, sensitivity and efficiency, the resolution bandwidth can be different from the reference bandwidth. When the resolution bandwidth is smaller than the reference bandwidth, the result should be integrated over the reference bandwidth. When the resolution bandwidth is greater than the reference bandwidth, the result for broadband spurious emissions should be normalized to the bandwidth ratio. For discrete spur, normalization is not applicable, while integration over the reference bandwidth is still applicable. The bandwidth used in this measurement for each spurious emission shall be sufficiently narrow to reject emissions in the five contiguous channels centred on the channel on which the transmitter is intended to operate.

The measurement shall be repeated with the transmitter in the "stand-by" position.

7.4.2.2 Method of measuring the effective radiated power with an external antenna connector (clause 7.4.1 b))

This method applies only to equipment with an external antenna connector.

On a test site, selected from annex A, the equipment shall be placed at the specified height on a non-conducting support.

The transmitter antenna connector shall be connected to an artificial antenna (see clause 6.2).

The output of the test antenna shall be connected to a measuring receiver.

The test antenna shall be orientated for vertical polarization and the length of the test antenna shall be chosen to correspond to the instantaneous frequency of the measuring receiver.

The transmitter shall be modulated with test signal C1 and the measurements made over the frequency range 30 MHz to 4 GHz.

For equipment operating on frequencies above 470 MHz the measurements shall also be performed over the frequency range 4 GHz to 12,75 GHz if emissions are detected within 10 dB of the of the specified limit between 1,5 GHz and 4 GHz.

The measurements are performed excluding the five contiguous channels centred on the channel on which the transmitter is intended to operate.

The transmitter shall be switched on with C1 modulation, and the measuring receiver shall be tuned over the frequency range 30 MHz to 4 GHz, except for the five contiguous channels centred on the channel on which the transmitter is intended to operate. At each frequency at which a discrete spurious component is detected, the test antenna shall be raised and lowered through the specified range of heights until a maximum signal level is detected on the measuring receiver. The resolution bandwidth of the measuring instrument shall be the smallest bandwidth available which is greater than the spectral width of the spurious component being measured. This shall be considered to be achieved when the next highest bandwidth causes less than 1 dB increase in amplitude.

When a test site according to clause A.1.1 is used there is no need to vary the height of the antenna.

The transmitter shall then be rotated through 360 ° in the horizontal plane, until the maximum signal level is detected by the measuring receiver.

The measuring receiver shall measure the mean power and this power shall be noted. The horizontal and vertical orientation of the antenna shall also be noted.

The transmitter shall be replaced by a substitution antenna as defined in clause A.1.5.

The substitution antenna shall be orientated for vertical polarization and the length of the substitution antenna shall be adjusted to correspond to the frequency of the spurious component detected.

The substitution antenna shall be connected to a calibrated signal generator.

The frequency of the calibrated signal generator shall be set to the frequency of the spurious component detected.

The input attenuator setting of the measuring receiver shall be adjusted in order to increase the sensitivity of the measuring receiver, if necessary.

The test antenna shall be raised and lowered through the specified range of heights to ensure that the maximum signal is received.

When a test site according to clause A.1.1 is used there is no need to vary the height of the antenna.

The input signal to the substitution antenna shall be adjusted to the level that produced a level detected by the measuring receiver, that is equal to the level noted while the spurious component was measured, corrected for the change of input attenuator setting of the measuring receiver.

The input level to the substitution antenna shall be recorded as power level.

The measurement shall be repeated with the test antenna and the substitution antenna orientated for horizontal polarization.

The measure of the effective radiated power of the spurious components is the larger of the two power levels recorded for each spurious component at the input to the substitution antenna, corrected for the gain of the antenna if necessary.

The measurement shall be repeated with the transmitter modulated by the test signal B1, M5 or M7 (as appropriate, see clause 6.1.1). If possible, the modulation should be continuous for the duration of the measurement. When burst transmission is used, the mean power of any spurious emissions shall be measured using averaging over the duration of the burst.

The measurement shall be repeated with the transmitter in the "stand-by" position.

7.4.2.3 Method of measuring the effective radiated power with an integral antenna (clause 7.4.1 c))

This method applies only to equipment without an external 50 Ω antenna connector.

The method of measurement shall be performed according to clause 7.4.2.2, except that the equipment and its antenna shall be mounted in a normal installation in its normal operating position while the output is connected to the integral antenna.

7.4.3 Limits

The power of any spurious emission, occurring more than $2,5 \times$ CSP from the centre of the channel on which the transmitter is intended to operate, shall not exceed the values given in tables 2 and 3.

Table 2: Conducted emissions

Frequency range	9 kHz to 1 GHz	Above 1 GHz to 4 GHz, or above 1 GHz to 12,75 GHz (see clause 7.4.2.1)
Tx operating	0,25 μ W (-36,0 dBm)	1,0 μ W (-30,0 dBm)
Tx Standby	2,0 nW (-57,0 dBm)	20,0 nW (-47,0 dBm)

Table 3: Radiated emissions

Frequency range	30 MHz to 1 GHz	Above 1 GHz to 4 GHz, or above 1 GHz to 12,75 GHz (see clause 7.4.2.2)
Tx operating	0,25 μ W (-36,0 dBm)	1,0 μ W (-30,0 dBm)
Tx Standby	2,0 nW (-57,0 dBm)	20,0 nW (-47,0 dBm)

The reference bandwidths used in clause 7.4.2.1 shall be as in tables 4a, 4b and 4c.

Table 4a: Reference bandwidths to be used for the measurement of spurious emissions outside the frequency offsets specified in table 4b (system below 1 GHz) or table 4c (systems above 1 GHz)

Frequency range	RBW
9 kHz to 150 kHz	1 kHz
150 kHz to 30 MHz	10 kHz
30 MHz to 1 GHz	100 kHz
1 GHz to 12,75 GHz	1 MHz

Table 4b: Reference bandwidths to be used close to the wanted emission for equipment operating below 1 GHz

Frequency offset from carrier	RBW
250 % of the CSP to 100 kHz	1 kHz
100 kHz to 500 kHz	10 kHz

Table 4c: Reference bandwidths to be used close to the wanted emission for equipment operating above 1 GHz

Frequency offset from carrier	RBW
250 % of the CSP to 100 kHz	1 kHz
100 kHz to 500 kHz	30 kHz
500 kHz to 1 MHz	300 kHz

Best measurement practice:

The resolution bandwidth of the measuring receiver should be equal to the reference bandwidth as given in the tables above. To improve measurement accuracy, sensitivity and efficiency, the resolution bandwidth can be different from the reference bandwidth. When the resolution bandwidth is smaller than the reference bandwidth, the result should be integrated over the reference bandwidth. When the resolution bandwidth is greater than the reference bandwidth, the result for broadband spurious emissions should be normalized to the bandwidth ratio. For discrete spurious emissions, normalization is not applicable, while integration over the reference bandwidth is still applicable.

7.5 Intermodulation attenuation

7.5.1 Definition

Intermodulation attenuation is the capability of a transmitter to avoid the generation of signals in the non-linear elements caused by the presence of the carrier and an interfering signal entering the transmitter via the antenna.

It is specified as the ratio, in dB, of the power level of the third order intermodulation product to the carrier power level.

7.5.2 Method of measurement

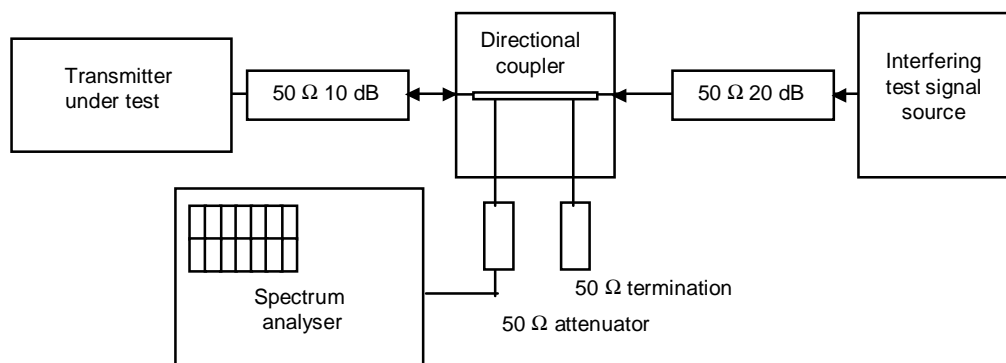

Figure 4: Measurement arrangement

This measurement applies only to transmitters to be used in base stations (fixed).

The measurement arrangement shown in figure 4 shall be used.

The transmitter shall be connected to a 50 Ω, 10 dB attenuator and via a directional coupler to a spectrum analyser. An additional attenuator may be required between the directional coupler and the spectrum analyser to avoid overloading the spectrum analyser.

In order to reduce the influence of mismatch errors it is important that the 10 dB power attenuator is coupled to the transmitter under test with the shortest possible connection.

The interfering test signal source is connected to the other end of the directional coupler via a 50 Ω, 20 dB attenuator.

The interfering signal source may be either a transmitter providing the same power output as the transmitter under test and be of a similar type or a signal generator and a power amplifier of equivalent intermodulation attenuation as that required from the transmitter, capable of delivering the same output power as the transmitter under test. In either case the interfering signal source shall be capable of generating a CW signal at power level equivalent to PX.

The directional coupler shall have an insertion loss of less than 1 dB, a sufficient bandwidth and a directivity of more than 20 dB.

The transmitter under test and the test signal source shall be physically separated in such a way that the measurement is not influenced by direct radiation.

Prior to the measurement, the maximum power level, PX, of the transmitter under test shall be measured according to clause 7.1 and the value recorded.

For non-constant envelope modulation test signal B1, M5 or M7 (as appropriate, see clause 6.1.1) shall be applied at the transmitter. For constant envelope modulation schemes it is not required to apply modulation. The modulation used, if any shall be recorded in the test report. The spectrum analyser shall be adjusted to display the maximum signal level. The frequency scan width shall be 500 kHz.

The interfering test signal source shall be a CW signal at a frequency within 50 kHz to 100 kHz above the frequency of the transmitter under test.

The frequency shall be chosen in such a way that the intermodulation components to be measured do not coincide with other spurious components. The power output of the interfering test signal source shall be adjusted to the PX level recorded above, by the use of a power meter.

The intermodulation components shall be measured by direct observation on the spectrum analyser of the ratio of the largest third order intermodulation component with respect to the power level PX.

This measurement shall be repeated with the interfering test signal source at a frequency within 50 kHz to 100 kHz below the frequency of the transmitter under test.

7.5.3 Limits

This requirement applies only to transmitters to be used in base stations (fixed).

Two classes of transmitter intermodulation attenuation are defined, the equipment shall fulfil one of the following requirements:

- the intermodulation attenuation ratio shall be at least 40,0 dB for any intermodulation component;
- for base station equipment to be used in special service conditions (e.g. at sites where more than one transmitter will be in service) or when the regulatory authority makes it a condition of the licence, the intermodulation attenuation ratio shall be at least 70,0 dB for any intermodulation component. In the case where the performance is achieved by additional internal or external isolating devices (such as circulators) these shall be used for the measurements.

7.6 Transient power

7.6.1 Definition

Transients power is the power falling into adjacent spectrum due to switching the transmitter on and off.

7.6.2 Method of measurement

The transmitter under test shall be connected via the power attenuator to the "transient power measuring device" as described in clause 7.6.2.1, so that the level at its input is suitable, e.g. between 0 dBm and -10 dBm when the transmitter power is the steady state power.

For non-constant envelope modulation test signal B1, M5 or M7 (as appropriate, see clause 6.1.1) shall be applied at the transmitter. For constant envelope modulation schemes it is not required to apply modulation. The modulation used, if any, shall be recorded in the test report.

The measurement procedure shall be as follows:

- a) the transmitter shall be operated at the maximum rated carrier power level, under normal test conditions (see clause 5.3);
- b) the tuning of the "transient power measuring device" shall be tuned to the operating channel and adjusted so that a maximum response is obtained. This is the 0 dBc reference level; The transmitter shall then be switched off;
- c) the tuning of the "transient power measuring device" shall be adjusted away from the centre of the channel so that its -6 dB response nearest to the transmitter channel centre frequency is located at a displacement from the nominal carrier frequency of 8,25 kHz;
- d) the transmitter shall be switched on;
- e) the spectrum analyser shall be used to record the envelope of the transient power as a function of time (approximately 50 ms duration). The peak envelope transient power shall be noted in dBc;
- f) the transmitter shall be switched off;

- g) the spectrum analyser shall be used to record the envelope of the transient power as a function of time (approximately 50 ms duration). The peak envelope transient power shall be noted in dBc;
- h) steps d) to g) shall be repeated five times and the highest response during "switch-on" and "switch-off" conditions shall be recorded;
- i) steps c) to h) shall be repeated with the "transient power measuring device" tuned to the other side of the channel;
- j) steps c) to i) shall be repeated with the tuning of the "transient power measuring device" adjusted away from the centre of the channel so that its -6 dB response nearest to the transmitter channel centre frequency is located at a displacements from the nominal carrier frequency of 25 kHz, 100 kHz and 1 MHz;
- k) the adjacent channel transient is the dBc value corresponding to the highest of the values recorded in step h); this value shall be recorded.

7.6.2.1 Characteristics of the transient power measuring device

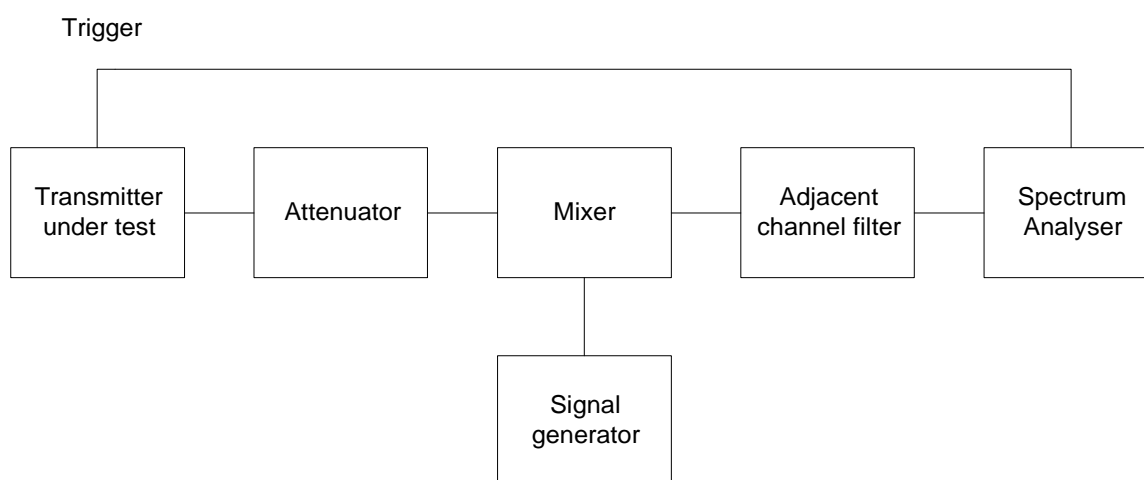

Figure 5: Transient power measuring device measurement arrangement

The adjacent channel transient power measuring device may be as follows:

- mixer: 50 Ω balanced diode mixer; with an appropriate local oscillator level, for example +7 dBm;
- adjacent channel filter: matched to 50 Ω (see annex D);
- spectrum analyser: 30 kHz bandwidth, peak detection, or power/time measurement provision.

7.6.3 Limits

The transient power in the adjacent channel shall not exceed a value of 50 dB below PX of the transmitter without the need to be below 2 μ W (-27,0 dBm).

For measurements at 100 kHz and 1 MHz the transient power shall not exceed 60 dB below PX of the transmitter without the need to be below 2 μ W (-27,0 dBm).

7.7 Frequency error

For equipment that can be measured for frequency error, under this clause, the manufacturer may choose to omit this test if the adjacent and alternate channel power is measured under extreme test conditions in clause 7.3.

7.7.1 Definition

The frequency error of the transmitter is the difference between the measured carrier frequency in the absence of modulation (or with modulation, provided that the presence of modulation allows sufficiently accurate measurement of the carrier frequency), and the nominal frequency of the transmitter.

7.7.2 Method of measurement

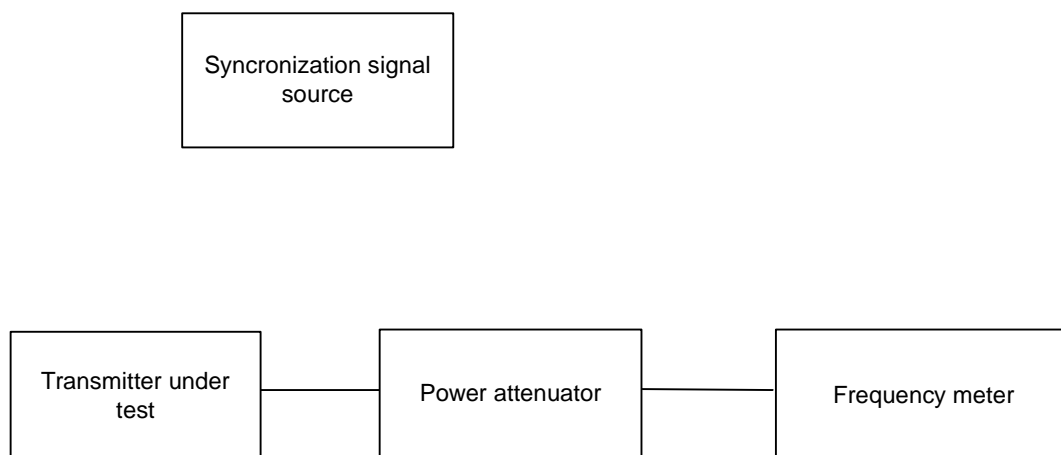

Figure 6: Measurement arrangement

The equipment shall be connected via the power attenuator to the frequency meter.

The carrier frequency shall be measured in the absence of modulation unless a particular signal exists that allows carrier frequency measurement. Such a signal shall be declared by the manufacturer. The measurement shall be made under normal test conditions (see clause 5.3) and extreme test conditions (see clauses 5.4.1 and 5.4.2 applied simultaneously).

For equipment that does not permit transmission without synchronizing to a base station the frequency error of the transmitter shall be measured after the equipment has synchronized to a suitable signal, as specified by the manufacturer. Such equipment shall prohibit start of transmission if synchronization has not been performed for greater than 1 minute prior to transmission.

Details of any synchronization signals used and timings of these signals shall be recorded in the test report.

7.7.3 Limits

The frequency error shall not exceed the values given in table 5, under normal and extreme test conditions, or in any intermediate set of conditions. However, for practical reasons the measurement shall be performed only at nominal and extreme test conditions.

Table 5: Frequency error

Frequency error limit				
Below 47 MHz	47 MHz to 137 MHz	Above 137 MHz to 300 MHz	Above 300 MHz to 500 MHz	Above 500 MHz
±0,30 kHz (B) ±0,1 CSP (M)	±0,30 kHz (B) ±0,1 CSP (M)	±0,30 kHz (B) ±0,1 CSP (M)	±0,50 kHz (B) ±0,1 CSP (M)	±0,50 kHz (B) ±0,1 CSP (M)
NOTE: For mobile and handportable equipment that is tested following synchronization (see clause 7.7.2) the frequency error shall at no time exceed the above limits up to 4 minutes after the start of transmission. For handportable equipment, these limits only apply to the reduced extreme temperature conditions 0°C to +40°C (see clause 5.4.1). At severe extreme temperature conditions -20 °C to +55 °C the frequency limit is ±0,25 CSP. (B) Base station. (M) Mobile station and handportable.				

8 Technical characteristics of the receiver

8.1 Maximum usable sensitivity (analogue, conducted)

8.1.1 Definition

The maximum usable sensitivity (analogue) of the receiver is the minimum level of signal (emf) at the receiver input, produced by a carrier at the nominal frequency of the receiver, modulated with the receiver analogue test signal (see clause 6.1.2), which will, without interference, produce after demodulation:

- an audio frequency output power of at least 50 % of the rated power output (see clause 6.11); and
- a SINAD ratio of 20 dB, measured at the receiver output through a telephone psophometric weighting network as described in ITU-T Recommendation O.41 [5].

8.1.2 Method of measuring the SINAD ratio

This method applies only to equipment capable of analogue transmission.

The measurement procedure shall be as follows:

- a) an input signal with a frequency equal to the nominal frequency of the receiver, modulated by the receiver analogue test signal (see clause 6.1.2), shall be applied to the receiver input terminals;
- b) the SINAD ratio shall be monitored;
where possible, the receiver volume control shall be adjusted to give at least 50 % of the rated output power (see clause 6.11) or in the case of stepped volume controls, to the first step that provides an output power of at least 50 % of the rated power;
- c) the level of the signal generator shall be adjusted until a psophometrically weighted SINAD ratio (or its acoustic equivalent) of 20 dB is obtained;
- d) the test signal input level (PEP) under these conditions is the value of the maximum usable sensitivity;
- e) the measurement shall be made under normal test conditions (see clause 5.3) and repeated under extreme test conditions (see clauses 5.4.1 and 5.4.2 applied simultaneously).

8.1.3 Limits

This requirement applies only to equipment capable of analogue transmission.

The maximum usable sensitivity shall not exceed an emf of 6,0 dB μ V under normal test conditions, and an emf of 12,0 dB μ V under extreme test conditions.

Under extreme test conditions, the receiver audio output power shall be within $\pm 3,0$ dB of the value obtained under normal test conditions.

For equipment capable of duplex operation an additional requirement is contained in clause 9.1.3.

8.2 Maximum usable sensitivity (analogue, field strength)

8.2.1 Definition

The maximum usable sensitivity (analogue) expressed as field strength is the field strength, expressed in dB μ V/m, produced by a carrier at the nominal frequency of the receiver, modulated with the receiver analogue test signal (see clause 6.1.2) which will, without interference, produce after demodulation a SINAD ratio of 20 dB measured through a psophometric weighting network.

8.2.2 Method of measurement

This method applies only to equipment without an external antenna connector.

It applies only to equipment capable of transmission of analogue information.

Arrangements shall be made to couple the equipment under test to the SINAD meter by a method which does not affect the radiated field (see clause A.3.3).

A test site which fulfils the requirements for the specified frequency range of this measurement shall be used (see annex A).

The test antenna shall be orientated for the polarization specified by the manufacturer and the length of the test antenna shall be chosen to correspond to the frequency of the receiver.

The equipment shall be placed at the specified height on a non-conducting support, in the position closest to the normal use declared by the manufacturer. The position shall be recorded in the test report.

A distortion factor meter incorporating a 1 000 Hz band-stop filter (or a SINAD meter) shall be connected to the receiver output terminals via a psophometric filter and an audio frequency load or by an acoustic coupler (see clause A.3.3.1) in order to avoid disturbing the electromagnetic field in the vicinity of the equipment.

- a) a signal generator shall be connected to the test antenna;

the signal generator shall be at the nominal frequency of the receiver and shall be modulated by the receiver analogue test modulation (see clause 6.1.2);
- b) the SINAD ratio shall be monitored;

where possible, the receiver volume control shall be adjusted to give at least 50 % of the rated output power (see clause 6.11) or in the case of stepped volume controls, to the first step that provides an output power of at least 50 % of the rated power;
- c) the level of the signal generator shall be adjusted until a psophometrically weighted SINAD ratio (or its acoustic equivalent) of 20 dB is obtained;
- d) the test antenna shall be raised or lowered through the specified height range to find the best psophometrically weighted SINAD ratio (or its acoustic equivalent);
- e) the level of the signal generator shall be re-adjusted until a SINAD ratio of 20 dB is obtained;
- f) the minimum signal generator level from step e) shall be noted and maintained;
- g) the receiver shall then be replaced by a substitution antenna as defined in clause A.1.5;

the substitution antenna shall be orientated for the polarization of the test antenna and the length of the substitution antenna shall be adjusted to correspond to the frequency of the receiver;
- h) the substitution antenna shall be connected to a calibrated measuring receiver;

the test antenna shall be raised and lowered through the specified range of height to ensure that the maximum signal is received;

the test antenna need not be raised or lowered if the measurement is carried out on a test site according to clause A.1.1;

- i) the signal PEP measured with the calibrated measuring receiver shall be recorded as the field strength in dB μ V/m;

the measurement shall be repeated with the test antenna and the substitution antenna orientated for horizontal polarization;

the measure of the maximum usable sensitivity expressed as field strength is the minimum of the two signal levels recorded as the input to the calibrated measuring receiver, corrected for the gain of the antenna if necessary.

8.2.3 Limits

This requirement applies only to equipment capable of transmission of analogue information and note having an external antenna connector.

The maximum usable sensitivity shall not exceed the field strength value shown in table 6.

Table 6: Maximum usable sensitivity (analogue)

Frequency band (MHz)	Field strength in dB relative to 1 μ V/m
	Normal test conditions
30 to 100	14,0
100 to 230	20,0
230 to 470	26,0
470 to 3 000	32,0

8.3 Maximum usable sensitivity (digital, conducted)

8.3.1 Definition

The maximum usable sensitivity (data) of the receiver is the minimum level of signal (emf) at the receiver input, at the nominal frequency of the receiver, with test signal M2 or M7 as appropriate (see clause 6.1.3), which without interference will produce after demodulation a data signal with a specified bit error ratio or a specified successful message ratio.

The specified bit error ratio is 10^{-2} . The specified successful message ratio is 0,8.

8.3.2 Methods of measurement

8.3.2.1 Method of measurement with continuous bit streams

This method applies only to equipment capable of transmission of digital information.

For equipment that supports adaptive rates, testing is only required at two bit rates, the minimum bit rate supported by the equipment and the maximum bit rate that the manufacturer declares is compliant to the present document.

The measurement procedure shall be as follows:

- an input signal with a centre frequency equal to the nominal centre frequency of the receiver, modulated by the test signal M2 (see clause 6.1.3) shall be applied to the receiver input terminals;
- the bit pattern of the modulating signal shall be compared to the bit pattern obtained from the receiver after demodulation;
- the emf of the input signal to the receiver is adjusted until the bit error ratio is 10^{-2} or better (when the value of 10^{-2} cannot be reached exactly), this shall be taken into account in the evaluation of the measurement uncertainty (TR 100 028 [i.1]);

- d) the maximum usable sensitivity is the emf of the signal at the input of the receiver;
- e) the measurement shall be made under normal test conditions (see clause 5.3) and repeated under extreme test conditions (see clauses 5.4.1 and 5.4.2 applied simultaneously).

8.3.2.2 Method of measurement with messages

In the case where operation using a continuous bit stream is not possible, the following method of measurement shall be applied:

- a) a signal with a centre frequency equal to the nominal centre frequency of the receiver and modulated with the test signal M6 (see clauses 6.1.3 and 6.4) in accordance with instructions of the manufacturer (and approved by the accredited test laboratory) shall be applied to the receiver input terminals;
- b) the level of this signal shall be such that a successful message rate of less than 10 % is obtained;
- c) the test signal M6 shall be transmitted repeatedly whilst observing in each case whether or not a successful response is obtained;
the input level shall be increased by 2 dB for each occasion that a successful response is not obtained;
the procedure shall be continued until three consecutive successive responses are observed;
the level of the input signal shall be noted;
- d) the input signal level shall be reduced by 1 dB and the new value noted;
the normal test signal shall then be transmitted 20 times. In each case, if a response **is not** obtained the input level shall be increased by 1 dB and the new value noted;
if a message is successfully received, the level of the input shall not be changed until three consecutive messages have been successfully received. In this case, the input level shall be reduced by 1 dB and the new value noted;
no level of the input signal shall be noted unless preceded by a change in level;
- e) the maximum usable sensitivity is the average of the values recorded in steps c) and d) (which provides the level corresponding to the successful message ratio of 80 %); this value shall be recorded;
- f) the measurement shall be made under normal test conditions (see clause 5.3) and repeated under extreme test conditions (see clauses 5.4.1 and 5.4.2 applied simultaneously).

8.3.3 Limits

This requirement applies only to equipment capable of transmission of digital information.

The maximum usable sensitivity shall not exceed an emf of 3,0 dB μ V under normal test conditions and 9,0 dB μ V under extreme test conditions for equipment operating with data rates of up to 2 400 bits per second.

The maximum usable sensitivity shall not exceed an emf of 6,0 dB μ V under normal test conditions and 12,0 dB μ V under extreme test conditions for equipment operating with data rates between 2 401 bits per second and 4 800 bits per second.

The maximum usable sensitivity shall not exceed an emf of 9,0 dB μ V under normal test conditions and 15,0 dB μ V under extreme test conditions for equipment operating with data rates between 4 801 bits per second and 9 600 bits per second.

The maximum usable sensitivity shall not exceed an emf of 15,0 dB μ V under normal test conditions and 21,0 dB μ V under extreme test conditions for equipment operating with data rates above 9 600 bits per second.

For equipment capable of duplex operation an additional requirement is contained in clause 9.1.3.

8.4 Maximum usable sensitivity (digital, field strength)

8.4.1 Definition

The maximum usable sensitivity (data) expressed as field strength is the field strength, expressed in dB μ V/m, produced by a carrier at the nominal frequency of the receiver, modulated with the test signal M2 or M6 (see clause 6.1.3) which will, without interference, produce after demodulation a data signal with a specified bit error ratio or a specified successful message ratio.

The specified bit error ratio is 10^{-2} . The specified successful message ratio is 0,8.

8.4.2 Method of measurement

This method applies only to equipment capable of transmission of digital information.

This measurement applies only for equipment without an external antenna connector.

For equipment that supports adaptive rates, testing is only required at two bit rates, the minimum bit rate supported by the equipment and the maximum bit rate that the manufacturer declares is compliant to the present document.

The manufacturer shall specify the polarization of the RF field for which the equipment has been designed.

Three test scenarios are possible:

- a) the manufacturer declares the direction corresponding to the maximum usable sensitivity. In this case this position is used to perform the measurement in clauses 8.4.2.1 or 8.4.2.2;
- b) if the manufacturer does not declare the position corresponding to the maximum usable sensitivity but provides an analogue output according to clause 6.12.1, then this output will be used to determine the direction of maximum usable sensitivity. This will be the position used for the measurement in clauses 8.4.2.1 or 8.4.2.2;
- c) if the direction corresponding to the maximum usable sensitivity cannot be determined as specified in a) or b) above, then an initial position will be used and the measurement in clauses 8.4.2.1 or 8.4.2.2 will be repeated with eight positions, 45 ° apart. The maximum usable sensitivity will be determined from the minimum field strength recorded.

8.4.2.1 Method of measurement with continuous bit streams

Arrangements shall be made by the manufacturer to couple the equipment under test to the bit error measuring device by a method which does not affect the radiated field (see also clauses 6.12.2 and 6.12.3.1).

A test site which fulfils the requirements for the specified frequency range of this measurement shall be used (see annex A).

The test antenna shall be orientated for the polarization specified by the manufacturer and the length of the test antenna shall be chosen to correspond to the frequency of the receiver.

The equipment and its antenna shall be mounted in a normal installation in its normal operating position and shall be placed at the specified height on a non-conducting support, in the position determined in clause 8.4.2. The position shall be recorded in the test report.

The raw bit stream produced by the receiver shall be monitored, preferably via a photo detector or an acoustic coupler in order to avoid disturbing the electromagnetic field in the vicinity of the equipment.

- a) a signal generator shall be connected to the test antenna;
the signal generator shall be at the nominal frequency of the receiver and shall have the test signal M2 (see clause 6.1.3);
- b) the bit pattern of the modulating signal shall be compared to the bit pattern provided by the receiver after demodulation, in order to obtain the bit error ratio;

- c) the level of the signal generator shall be adjusted until a bit error ratio of approximately 10^{-1} is obtained;
- d) the test antenna shall be raised or lowered through the specified height range to find the lowest bit error ratio;
the test antenna may not need to be raised or lowered if a test site according to clause A.1.1 is used, or if the ground floor reflection can effectively be eliminated;
- e) the level of the signal generator shall be re-adjusted until a bit error ratio of 10^{-2} is obtained; the input signal level to the test antenna shall be noted and maintained;
- f) the receiver shall then be replaced by a substitution antenna as defined in clause A.1.5;
the substitution antenna shall be orientated for the polarization of the test antenna and the length of the substitution antenna shall be adjusted to correspond to the frequency of the receiver;
- g) the substitution antenna shall be connected to a calibrated measuring receiver;
the test antenna shall be raised and lowered through the specified range of height to ensure that the maximum signal is received;
the test antenna need not be raised or lowered if the measurement is carried out on a test site according to clause A.1.1;
- h) the measured signal level shall be recorded as field strength in dB μ V/m, this is the maximum usable sensitivity, corresponding to the direction used.

8.4.2.2 Method of measurement with messages

In the case where operation using a continuous bit stream is not possible, the following method of measurement shall be applied.

Arrangements shall be made by the manufacturer to couple the equipment under test to the message measuring device by a method which does not affect the radiated field (see clause 6.12.3.2).

A test site which fulfils the requirements for the specified frequency range of this measurement shall be used (see annex A).

The test antenna shall be orientated for the polarization specified by the manufacturer and the length of the test antenna shall be chosen to correspond to the frequency of the receiver.

The equipment and its antenna shall be mounted in a normal installation in its normal operating position and shall be placed at the specified height on a non-conducting support, in the position determined in clause 8.4.2. The position shall be recorded in the test report.

A message measuring device shall be coupled to the receiver, preferably via a photo detector or an acoustic coupler in order to avoid disturbing the electromagnetic field in the vicinity of the equipment.

- a) a signal generator shall be connected to the test antenna;
the signal generator shall be at the nominal frequency of the receiver and shall have the test signal M6 (see clause 6.1.3);
- b) the level of the signal generator shall be adjusted until a successful message ratio of less than 10 % is obtained;
- c) the test antenna shall be raised or lowered through the specified height range to find the maximum successful message ratio;
the test antenna may not need to be raised or lowered if a test site according to clause A.1.1 is used, or if the ground floor reflection can effectively be eliminated;
the level of the test signal shall be re-adjusted to produce the successful message ratio specified in step b);
- d) the minimum signal generator level from step c) shall be noted;

- e) the test signal M6 shall be transmitted repeatedly whilst observing in each case whether or not a message is successfully received;
- the level of the test signal shall be increased by 2 dB for each occasion that a message is not successfully received;
- the procedure shall be continued until three consecutive messages are successfully received;
- this level as the minimum signal generator level in this direction shall be noted;
- f) the level of the test signal shall be reduced by 1 dB and the new value shall also be noted;
- the test signal M6 (see clause 6.1.3) shall then be transmitted 20 times. In each case, if a message is not successfully received, the level shall be increased by 1 dB and the new value noted;
- if a message is successfully received, the level shall not be changed until three consecutive messages have been successfully received;
- in this case, the level shall be reduced by 1 dB and the new value noted;
- no signal level shall be noted unless preceded by a change in level;
- the average of the values noted in steps e) and f) corresponds to the successful message ratio of 80 %; this input signal level to the test antenna shall be noted and maintained;
- g) the receiver shall then be replaced by a substitution antenna as defined in clause A.1.5;
- the substitution antenna shall be orientated for the polarization of the test antenna and the length of the substitution antenna shall be adjusted to correspond to the frequency of the receiver;
- h) the substitution antenna shall be connected to a calibrated measuring receiver;
- the test antenna shall be raised and lowered through the specified range of height to ensure that the maximum signal is received;
- the test antenna need not be raised or lowered if the measurement is carried out on a test site according to clause A.1.1;
- i) the measured signal level shall be recorded as field strength in dB μ V/m, this is the maximum usable sensitivity, corresponding to the direction used.

8.4.3 Limits

This requirement applies only to equipment capable of transmission of digital information and not having an external antenna connector.

The maximum usable sensitivity shall not exceed the field strength value shown in table 7.

Table 7: Maximum usable sensitivity (data)

Frequency band (MHz)	Data Rate (bits per second)	Field strength in dB relative to 1 μ V/m (dB) (Normal test conditions)
30 to 100	Up to 2 400	11
	Between 2 401 and 4 800	14
	Between 4 801 and 9 600	17
	Above 9 601	23
100 to 230	Up to 2 400	17
	Between 2 401 and 4 800	20
	Between 4 801 and 9 600	23
	Above 9 601	29
230 to 470	Up to 2 400	23
	Between 2 401 and 4 800	26
	Between 4 801 and 9 600	29
	Above 9 601	35
470 to 3 000	Up to 2 400	29
	Between 2 401 and 4 800	32
	Between 4 801 and 9 600	35
	Above 9 601	41

8.5 Adjacent channel selectivity

8.5.1 Definition

The adjacent channel selectivity is the measure of the capability of the receiver to receive a wanted modulated signal at the nominal frequency without exceeding a given degradation due to the presence of an unwanted signal which differs in frequency from the wanted signal by an amount equal to the adjacent CSP for which the equipment is intended.

8.5.2 Method of measurement

The CSP of the equipment shall be declared by the manufacturer.

8.5.2.1 Method of measurement (analogue)

The measurement procedure shall be as follows:

- a) two signal generators, A and B, shall be connected to the receiver via a combining network (see clause 6.9);
the wanted signal, provided by signal generator A, shall be at the nominal frequency of the receiver and shall have receiver analogue test modulation, (see clause 6.1.2);
the unwanted signal, provided by signal generator B, shall be modulated test signal M4 (see clause 6.1.3) and shall be at the frequency of the channel immediately above that of the wanted signal;

- b) initially, signal generator B (unwanted signal) shall be switched off (maintaining the output impedance);
the level of the wanted signal from generator A shall be adjusted to the level which is the value of the limit for the maximum usable sensitivity (i.e. 6 dB above 1 μ V emf under normal test conditions);
where possible, the receiver volume control shall be adjusted to give at least 50 % of the rated output power (see clause 6.11) or, in the case of stepped volume controls, to the first step that provides an output power of at least 50 % of the rated output power. The obtained audio output level shall be noted;
- c) the unwanted signal from generator B shall then be switched on;
- d) the level of generator B shall be adjusted so that the unwanted signal causes:
- a reduction of 3 dB in the output level of the wanted signal; or
 - a reduction to 14 dB of the SINAD ratio at the receiver output (with a psophometric filter), whether or not measured acoustically;
- whichever occurs first;
- e) the level of the unwanted signal shall be noted;
- f) for each adjacent channel, the selectivity shall be expressed as the ratio, in dB, of the level of the unwanted signal to the level of the wanted signal, at the receiver input; this ratio shall be recorded;
- g) the measurement shall be repeated with the unwanted signal at the frequency of the channel below that of the wanted signal;
- h) the adjacent channel selectivity of the equipment under test shall be expressed as the lower of the two values measured in the upper and lower channels nearest to the receiving channel (see step f) above);
- i) the measurement shall be repeated under extreme test conditions (see clauses 5.4.1 and 5.4.2 applied simultaneously), with the level of the wanted signal adjusted to the level which is 6 dB above the value of the limit for the maximum usable sensitivity (i.e. 12 dB above 1 μ V emf).

8.5.2.2 Method of measurement (digital with continuous bit stream)

For digital equipment that supports adaptive rates, testing is only required at the maximum bit rate that the manufacturer declares is compliant to the present document.

The measurement procedure shall be as follows:

- a) two signal generators, A and B, shall be connected to the receiver via a combining network (see clause 6.9);
the wanted signal, provided by signal generator A, shall be at the nominal frequency of the receiver and shall be modulated by the test signal M2 (see clause 6.1.3);
the unwanted signal, provided by signal generator B, shall be modulated test signal M4 (see clause 6.1.3) and shall be at the frequency of the channel immediately above that of the wanted signal;
- b) initially, signal generator B (unwanted signal) shall be switched off (maintaining the output impedance);
the level of the wanted signal from generator A shall be adjusted to the level which is 3 dB above the relevant limit in clause 8.3.3, at the receiver input terminals;
- c) signal generator B shall then be switched on, and the level of the unwanted signal adjusted until a bit error ratio of 10^{-1} or worse is obtained;
- d) the test signal M2 shall be transmitted whilst observing the bit error ratio;
- e) the level of the unwanted signal shall be reduced in steps of 1 dB until a bit error ratio of 10^{-2} or better is obtained. The level of the unwanted signal shall then be noted;
- f) for each adjacent channel, the selectivity shall be expressed as the ratio, in dB, of the level of the unwanted signal to the level of the wanted signal, at the receiver input. This ratio shall be recorded;

- g) the measurement shall be repeated with the unwanted signal at the frequency of the channel below that of the wanted signal;
- h) the adjacent channel selectivity of the equipment under test shall be expressed as the lower of the two values measured in the upper and lower channels nearest to the receiving channel (see step f) above);
- i) the measurement shall be repeated under extreme test conditions (see clauses 5.4.1 and 5.4.2 applied simultaneously), with the amplitude of the wanted test signal adjusted to an emf 9 dB above the relevant limit in clause 8.3.3, unless analogue selectivity measurements were made, in which case the selectivity (data) has to be measured only under normal test conditions.

8.5.2.3 Method of measurement with messages

For digital equipment that supports adaptive rates, testing is only required at the maximum bit rate that the manufacturer declares is compliant to the present document.

In the case where operation using a continuous bit stream is not possible, the following method of measurement shall be applied.

The measurement procedure shall be as follows:

- a) two signal generators, A and B, shall be connected to the receiver via a combining network (see clause 6.9);
the wanted signal, provided by signal generator A, shall be at the nominal frequency of the receiver and shall have test signal M6 (see clause 6.1.3);
the unwanted signal, provided by signal generator B, shall be modulated test signal M4 (see clause 6.1.3) and shall be at the frequency of the channel immediately above that of the wanted signal;
- b) initially, signal generator B (unwanted signal) shall be switched off (maintaining the output impedance);
the level of the wanted signal from generator A shall be adjusted to the level which is 3 dB above the relevant limit in clause 8.3.3, at the receiver input terminals;
- c) signal generator B shall then be switched on, and the level of the unwanted signal adjusted until a successful message ratio of less than 10 % is obtained;
- d) the test signal M6 (see clause 6.1.3) shall then be transmitted repeatedly whilst observing in each case whether or not a message is successfully received;
the level of the unwanted signal shall be reduced by 2 dB for each occasion that a message is not successfully received;
the procedure shall be continued until three consecutive messages are successfully received. The level of the input signal shall then be noted;
- e) the level of the unwanted signal shall be increased by 1 dB and the new value noted;
the normal test signal (see clause 7.3) shall then be transmitted 20 times. In each case, if a message is not successfully received the level of the unwanted signal shall be reduced by 1 dB and the new value noted;
if a message is successfully received, the level of the unwanted signals shall not be changed until three consecutive messages have been successfully received. In this case the unwanted signal shall be increased by 1 dB and the new value noted;
no level of the unwanted signal shall be noted unless preceded by a change in level;
the average of the values noted in steps d) and e) (which provides the level corresponding to the successful message ratio of 80 %) shall be noted;
- f) for each adjacent channel, the selectivity shall be expressed as the ratio, in dB, of the level of the unwanted signal to the level of the wanted signal, at the receiver input. This ratio shall be recorded;
- g) the measurement shall be repeated with the unwanted signal at the frequency of the channel below that of the wanted signal;

- h) the adjacent channel selectivity of the equipment under test shall be expressed as the lower of the two values measured in the upper and lower channels nearest to the receiving channel (see step f) above);
- i) the measurement shall be repeated under extreme test conditions (see clauses 5.4.1 and 5.4.2 applied simultaneously), with the amplitude of the wanted test signal adjusted to an emf 9 dB above in clause 8.3.3, unless analogue selectivity measurements were made, in which case the selectivity (data) has to be measured only under normal test conditions.

8.5.3 Limits

The minimum adjacent channel rejection shall be:

- 60 dB for base station equipment under normal test conditions and 50 dB under extreme test conditions;
- 54 dB for mobile equipment under normal test conditions and 44 dB under extreme test conditions;
- 50 dB for handportable equipment under normal test conditions and 40 dB under extreme test conditions.

8.6 Spurious response rejection

8.6.1 Definition

The spurious response rejection is a measure of the capability of the receiver to receive a wanted modulated signal without exceeding a given degradation due to the presence of an unwanted modulated signal at any other frequency, at which a response is obtained.

8.6.2 Method of measurement

8.6.2.1 Introduction to the method of measurement

Spurious responses may occur at all frequencies throughout the frequency spectrum and the requirements of the present document shall be met for all frequencies. However, for practical reasons the measurements for testing shall be performed as specified in the present document. More specifically, this method of measurement is not intended to capture all spurious responses but selects those that have a high probability of being present. However, in a limited frequency range close to the nominal frequency of the receiver, it has been considered impossible to determine the probability of a spurious response and therefore a search shall be performed over this limited frequency range. This method provides a high degree of confidence that the equipment also meets the requirements at frequencies not being measured.

For digital equipment that supports adaptive rates, testing is only required at the maximum bit rate that the manufacturer declares is compliant to the present document.

To determine the frequencies at which spurious responses can occur the following calculations shall be made:

- a) calculation of the "limited frequency range":
 - the limited frequency range is defined as the frequency of the local oscillator signal (f_{LO}) applied to the first mixer of the receiver plus or minus the sum of the intermediate frequencies (f_{I1}, \dots, f_{In}) and a half the (sr) of the receiver;
 - hence, the frequency f_l of the limited frequency range is:

$$f_{LO} - \sum_{j=1}^{j=n} f_{Ij} - \frac{sr}{2} \leq f_l \leq f_{LO} + \sum_{j=1}^{j=n} f_{Ij} + \frac{sr}{2}$$

- b) calculation of frequencies outside the limited frequency range:
- a calculation of the frequencies at which spurious responses can occur outside the range determined in a) is made for the remainder of the frequency range of interest, as appropriate (see clauses 8.6.2.3, 8.6.2.4 and 8.6.2.5);
 - the frequencies outside the limited frequency range are equal to the harmonics of the frequency of the local oscillator signal (f_{LO}) applied to the first mixer of the receiver plus or minus the first intermediate frequency (f_{I1}) of the receiver;
 - hence, the frequencies of these spurious responses are:

$$n f_{LO} \pm f_{I1}$$

- where n is an integer greater than or equal to 2;

the measurement of the first image response of the receiver shall initially be made to verify the calculation of spurious response frequencies.

For the calculations a) and b) above, the manufacturer shall state the frequency of the receiver, the frequency of the local oscillator signal (f_{LO}) applied to the 1st mixer of the receiver, the intermediate frequencies (f_{I1} , f_{I2} , etc.), and the SR of the receiver.

8.6.2.2 Method of search over the "limited frequency range"

The measurement procedure shall be as follows:

- a) two signal generators, A and B, shall be connected to the receiver via a combining network (see clause 6.9);
the wanted signal, provided by signal generator A, shall be at the nominal frequency of the receiver and shall have the appropriate test signal (see clauses 6.1.2 and 6.1.3);
the unwanted signal, provided by signal generator B, shall be modulated with test signal M3 (see clause 6.1.3);
- b) initially, signal generator B (unwanted signal) shall be switched off (maintaining the output impedance);
the level of the wanted signal from generator A shall be adjusted to the level which is 3 dB above the appropriate limit of the maximum usable sensitivity as specified in clauses 8.1 or 8.3.3;
in the case where a continuous bit stream is used, the bit error ratio of the receiver after demodulation shall be noted;
- c) signal generator B shall then be switched on, and the level of the unwanted signal adjusted to 86 dB μ V at the receiver input terminals;
the frequency of the unwanted signal generator shall be varied in increments of 50 % of the CSP of the equipment, over the limited frequency range (see clause 8.6.2.1 a)) and over the frequencies in accordance with the calculations outside of this frequency range (see clause 8.6.2.1 b));
- d) the frequency of any spurious response detected (e.g. by an increase in the previously noted bit error ratio or degradation of SINAD) during the search shall be recorded for use in the measurements in accordance with clauses 8.6.2.3, 8.6.2.4 and 8.6.2.5;
- e) in the case of digital equipment where operation using a continuous bit stream is not possible a similar method shall be used. In such case, instead of identifying a spurious response by noting an increase in the bit error ratio, spurious responses shall be identified by a degradation of the successful message ratio.

8.6.2.3 Method of measurement (analogue)

The measurement shall be performed as follows:

- a) two signals generators, A and B, shall be connected to the receiver via a combining network (see clause 6.9);
the wanted signal, provided by signal generator A, shall be at the nominal frequency of the receiver and shall have receiver analogue test modulation, (see clause 6.1.2);
the unwanted signal, provided by signal generator B, shall be modulated with test signal M3 (see clause 6.1.3), and shall be at the frequency of that spurious response being considered;
- b) initially, signal generator B (unwanted signal) shall be switched off (maintaining the output impedance);
the level of the wanted signal from generator A shall be adjusted to the level which is the value of the limit for the maximum usable sensitivity (i.e. 6 dB above 1 μ V emf under normal test conditions);
where possible, the receiver volume control shall be adjusted to give at least 50 % of the rated output power (see clause 6.11) or, in the case of stepped volume controls, to the first step that provides an output power of at least 50 % of the rated output power. The obtained audio output level shall be noted;
- c) the unwanted signal from generator B shall then be switched on;
- d) the level of generator B shall be adjusted so that the unwanted signal causes:
 - a reduction of 3 dB in the output level of the wanted signal; or
 - a reduction to 14 dB of the SINAD ratio at the receiver output (with a psophometric filter), whether or not measured acoustically;
 whichever occurs first;
- e) the level of the unwanted signal shall be noted;
- f) the frequency of the unwanted signal shall be stepped up and down in increments of 20 % of the CSP and steps d) and e) shall be repeated until the lowest level noted in step e) is obtained; this value shall be recorded;
- g) the measurement shall be repeated at all spurious response frequencies found during the search over the "limited frequency range" (see clause 8.6.2.1a) and at frequencies calculated for the remainder of the spurious response frequencies (see clause 8.6.2.1 b)) in the frequency range from 100 kHz to 2 GHz for equipment operating on frequencies not exceeding 470 MHz or in the frequency range 100 kHz to 4 GHz for equipment operating above 470 MHz;
- h) the spurious response rejection of the equipment under test shall be expressed as the lowest value recorded in step f).

8.6.2.4 Method of measurement (digital with continuous bit streams)

The measurement shall be performed as follows:

- a) two signals generators, A and B, shall be connected to the receiver via a combining network (see clause 6.9);
the wanted signal, provided by signal generator A, shall be at the nominal frequency of the receiver and shall be modulated by the test signal M2 (see clause 6.1.3);
the unwanted signal, provided by signal generator B, shall be modulated with test signal M3 (see clause 6.1.3), and shall be at the frequency of that spurious response being considered;
- b) initially, signal generator B (unwanted signal) shall be switched off (maintaining the output impedance);
the level of the wanted signal from generator A shall be adjusted to the level which is 3 dB above the relevant limit in clause 8.3.3, at the receiver input terminals;
- c) signal generator B shall then be switched on, and the level of the unwanted signal adjusted until a bit error ratio of 10^{-1} or worse is obtained;

- d) the normal test signal M2 shall be transmitted whilst observing the bit error ratio;
- e) the level of the unwanted signal shall be reduced in steps of 1 dB until a bit error ratio of 10^{-2} or better is obtained. The level of the unwanted signal shall then be noted;
- f) the frequency of the unwanted signal shall be stepped up and down in increments of 20 % of the CSP and step e) shall be repeated until the lowest level noted in step e) is obtained; this value shall be recorded;
- g) the measurement shall be repeated at all spurious response frequencies found during the search over the "limited frequency range" (see clause 8.6.2.1 a)) and at frequencies calculated for the remainder of the spurious response frequencies (see clause 8.6.2.1 b)) in the frequency range from 100 kHz to 2 GHz for equipment operating on frequencies not exceeding 470 MHz or in the frequency range 100 kHz to 4 GHz for equipment operating above 470 MHz;
- h) the spurious response rejection of the equipment under test shall be expressed as the lowest value recorded in step f).

8.6.2.5 Method of measurement (digital with messages)

In the case where operation using a continuous bit stream is not possible, the following method of measurement shall be applied.

The measurement shall be performed as follows:

- a) two signal generators, A and B, shall be connected to the receiver via a combining network (see clause 6.9);
the wanted signal, provided by signal generator A, shall be at the nominal frequency of the receiver and shall be modulated by the test signal M6 (see clause 6.1.3);
the unwanted signal, provided by signal generator B, shall be modulated with test signal M3 (see clause 6.1.3), and shall be at the frequency of that spurious response being considered;
- b) initially, signal generator B (unwanted signal) shall be switched off (maintaining the output impedance);
the level of the wanted signal from generator A shall be adjusted to the level which is 3 dB above the relevant limit in clause 8.3.3, at the receiver input terminals;
- c) signal generator B shall then be switched on, and the level of the unwanted signal adjusted until a successful message ratio of less than 10 % is obtained;
- d) the test signal M6 (see clause 6.1.3) shall then be transmitted repeatedly whilst observing in each case whether or not a message is successfully received;
the level of the unwanted signal shall be reduced by 2 dB for each occasion that a message is not successfully received;
the procedure shall be continued until three consecutive messages are successfully received. The level of the input signal shall then be noted;
- e) the level of the unwanted signal shall be increased by 1 dB and the new value noted;
the test signal M6 (see clause 6.1.3) shall then be transmitted 20 times. In each case, if a message is not successfully received the level of the unwanted signal shall be reduced by 1 dB and the new value noted;
if a message is successfully received, the level of the unwanted signal shall not be changed until three consecutive messages have been successfully received. In this case the unwanted signal shall be increased by 1 dB and the new value noted;
no level of the unwanted signal shall be noted unless preceded by a change in level;
the average of the values noted in steps d) and e) (which provides the level corresponding to the successful message ratio of 80 %) shall be noted;
- f) the frequency of the unwanted signal shall be stepped up and down in increments of 20 % of the CSP and steps d) and e) shall be repeated until the lowest level noted in step e) is obtained. This value shall be recorded;

- g) the measurement shall be repeated at all spurious response frequencies found during the search over the "limited frequency range" (see clause 8.6.2.1 a)) and at frequencies calculated for the remainder of the spurious response frequencies (see clause 8.6.2.1 b)) in the frequency range from 100 kHz to 2 GHz for equipment operating on frequencies not exceeding 470 MHz or in the frequency range 100 kHz to 4 GHz for equipment operating above 470 MHz;
- h) the spurious response rejection of the equipment under test shall be expressed as the lowest value recorded in step f).

8.6.3 Limits

At any frequency separated from the nominal frequency of the receiver by more than 250 % of CSP but less than 25 kHz, the spurious response rejection shall be such that under the specified test conditions, the given degradation shall not be exceeded for levels of the unwanted signal up to 66,0 dB μ V.

At any frequency separated from the nominal frequency of the receiver by 25 kHz or more, the spurious response rejection shall be such that under the specified test conditions, the given degradation shall not be exceeded for levels of the unwanted signal up to 76,0 dB μ V.

8.7 Intermodulation response rejection

8.7.1 Definition

The intermodulation response rejection is a measure of the capability of the receiver to receive a wanted modulated signal, without exceeding a given degradation due to the presence of two or more unwanted signals with a specific frequency relationship to the wanted signal frequency.

8.7.2 Method of measurement

8.7.2.1 Method of measurement (analogue)

The measurement procedure shall be as follows:

- a) three signal generators, A, B and C, shall be connected to the receiver via a combining network (see clause 6.9);
 - the wanted signal, provided by signal generator A, shall be at the nominal frequency of the receiver and shall have receiver analogue test modulation, (see clause 6.1.2);
 - the first unwanted signal, provided by signal generator B, shall be unmodulated and adjusted to a frequency 25 kHz above the nominal frequency of the receiver;
 - the second unwanted signal, provided by signal generator C, shall be modulated with test signal M3 (see clause 6.1.3) and adjusted to a frequency 50 kHz above the nominal frequency of the receiver;
- b) initially, signal generators B and C (unwanted signals) shall be switched off (maintaining the output impedance);
 - the level of the wanted signal from generator A shall be adjusted to the level which is the value of the limit for the maximum usable sensitivity (i.e. 6 dB above 1 μ V emf under normal test conditions);
 - where possible, the receiver volume control shall be adjusted to give at least 50 % of the rated output power (see clause 6.11) or, in the case of stepped volume controls, to the first step that provides an output power of at least 50 % of the rated output power. The obtained audio output level shall be noted;
- c) the unwanted signals from generators B and C shall then be switched on;

- d) their levels shall be maintained equal and shall be adjusted so that the unwanted signal causes:
- a reduction of 3 dB in the output level of the wanted signal; or
 - a reduction to 14 dB of the SINAD ratio at the receiver output (with a psophometric filter), whether or not measured acoustically;
- whichever occurs first;
- e) the level of the unwanted signals shall be noted;
- f) for each configuration of the unwanted signals, the intermodulation response rejection shall be recorded as the lowest value noted in step e);
- g) the measurement shall be repeated with the unwanted signal generator B at the frequency 25 kHz below that of the wanted signal and the frequency of the unwanted signal generator C at the frequency 50 kHz below that of the wanted signal;
- the measurement shall also be repeated with the unwanted signal generator B at the frequency 50 kHz below that of the wanted signal and the frequency of the unwanted signal generator C at the frequency 100 kHz below that of the wanted signal;
- the measurement shall be repeated again with the unwanted signal generator B at the frequency 50 kHz above that of the wanted signal and the frequency of the unwanted signal generator C at the frequency 100 kHz above that of the wanted signal;
- h) the intermodulation response rejection of the equipment under test shall be expressed as the lowest of the values recorded in step f).

8.7.2.2 Method of measurement (digital with continuous bit stream)

For digital equipment that supports adaptive rates, testing is only required at the maximum bit rate that the manufacturer declares is compliant to the present document.

The measurement procedure shall be as follows:

- a) three signal generators, A, B and C, shall be connected to the receiver via a combining network (see clause 6.9);
- the wanted signal, provided by signal generator A, shall be at the nominal frequency of the receiver and shall be modulated by the test signal M2 (see clause 6.1.3);
- the first unwanted signal, provided by signal generator B, shall be unmodulated and adjusted to a frequency 25 kHz above the nominal frequency of the receiver;
- the second unwanted signal, provided by signal generator C, shall be modulated with test signal M3 (see clause 6.1.3) and adjusted to a frequency 50 kHz above the nominal frequency of the receiver;
- b) initially, signal generators B and C (unwanted signals) shall be switched off (maintaining the output impedance);
- the level of the wanted signal from generator A shall be adjusted to the level which is 3 dB above the relevant limit in clause 8.3.3, at the receiver input terminals;
- c) signal generators B and C shall then be switched on, and the level of the two unwanted signals shall be maintained equal and shall be adjusted until a bit error ratio of 10^{-1} or worse is obtained;
- d) the test signal M2 shall be transmitted whilst observing the bit error ratio;
- e) the level of the unwanted signals shall be reduced in steps of 1 dB until a bit error ratio of 10^{-2} or better is obtained. The level of the unwanted signals shall then be noted;
- f) for each configuration of the unwanted signals, the intermodulation response rejection shall be recorded as the lowest value noted in step e);

- g) the measurement shall be repeated with the unwanted signal generator B at the frequency 25 kHz below that of the wanted signal and the frequency of the unwanted signal generator C at the frequency 50 kHz below that of the wanted signal;

the measurement shall also be repeated with the unwanted signal generator B at the frequency 50 kHz below that of the wanted signal and the frequency of the unwanted signal generator C at the frequency 100 kHz below that of the wanted signal;

the measurement shall be repeated again with the unwanted signal generator B at the frequency 50 kHz above that of the wanted signal and the frequency of the unwanted signal generator C at the frequency 100 kHz above that of the wanted signal;

- h) the intermodulation response rejection of the equipment under test shall be expressed as the lowest of the values recorded in step f).

8.7.2.3 Method of measurement with messages

For digital equipment that supports adaptive rates, testing is only required at the maximum bit rate that the manufacturer declares is compliant to the present document.

In the case where operation using a continuous bit stream is not possible, the following method of measurement shall be applied.

The measurement procedure shall be as follows:

- a) three signal generators, A, B and C, shall be connected to the receiver via a combining network (see clause 6.9);
- the wanted signal, provided by signal generator A, shall be at the nominal frequency of the receiver and shall have test signal M6 (see clause 6.1.3);
- the first unwanted signal, provided by signal generator B, shall be unmodulated and adjusted to a frequency 25 kHz above the nominal frequency of the receiver;
- the second unwanted signal, provided by signal generator C, shall be modulated with test signal M3 (see clause 6.1.3) and adjusted to a frequency 50 kHz above the nominal frequency of the receiver;
- b) initially, signal generator B (unwanted signal) shall be switched off (maintaining the output impedance);
- the level of the wanted signal from generator A shall be adjusted to the level which is 3 dB above the relevant limit or manufacturer's declaration in clause 8.3.3, at the receiver input terminals;
- c) signal generators B and C shall then be switched on; the levels of the two unwanted signals shall be maintained equal and shall be adjusted until a successful message ratio of less than 10 % is obtained;
- d) the test signal M6 (see clause 6.1.3) shall then be transmitted repeatedly whilst observing in each case whether or not a message is successfully received;
- the level of the unwanted signal shall be reduced by 2 dB for each occasion that a message is not successfully received;
- the procedure shall be continued until three consecutive messages are successfully received. The level of the input signal shall then be noted;
- e) the level of the unwanted signal shall be increased by 1 dB and the new value noted;
- the normal test signal (see clause 7.3) shall then be transmitted 20 times. In each case, if a message is not successfully received the level of the unwanted signal shall be reduced by 1 dB and the new value noted;
- if a message is successfully received, the level of the unwanted signals shall not be changed until three consecutive messages have been successfully received. In this case the unwanted signal shall be increased by 1 dB and the new value noted;
- no level of the unwanted signal shall be noted unless preceded by a change in level;

the average of the values noted in steps d) and e) (which provides the level corresponding to the successful message ratio of 80 %) shall be noted;

- f) for each configuration of the unwanted signals, the intermodulation response rejection shall be recorded as the lowest value noted in step e);
- g) the measurement shall be repeated with the unwanted signal generator B at the frequency 25 kHz below that of the wanted signal and the frequency of the unwanted signal generator C at the frequency 50 kHz below that of the wanted signal;

the measurement shall also be repeated with the unwanted signal generator B at the frequency 50 kHz below that of the wanted signal and the frequency of the unwanted signal generator C at the frequency 100 kHz below that of the wanted signal;

the measurement shall be repeated again with the unwanted signal generator B at the frequency 50 kHz above that of the wanted signal and the frequency of the unwanted signal generator C at the frequency 100 kHz above that of the wanted signal;

- h) the intermodulation response rejection of the equipment under test shall be expressed as the lowest of the values recorded in step f).

8.7.3 Limit

The intermodulation response rejection of the equipment shall be such that under the specified test conditions, the given degradation shall not be exceeded for levels of the unwanted signal up to 76 dB μ V for base stations and 71 dB μ V for mobile and handportable stations.

8.8 Blocking or desensitization

8.8.1 Definition

Blocking is a measure of the capability of the receiver to receive a wanted modulated signal without exceeding a given degradation due to the presence of an unwanted input signal at any frequencies other than those of the spurious responses or the adjacent channels.

8.8.2 Method of measurement

8.8.2.1 Method of measurement (analogue)

The measurement procedure shall be as follows:

- a) two signal generators, A and B, shall be connected to the receiver via a combining network (see clause 6.9); the wanted signal, provided by signal generator A, shall be at the nominal frequency of the receiver and shall have receiver analogue test modulation, (see clause 6.1.2);

the unwanted signal, provided by signal generator B, shall be unmodulated and shall be at a frequency from 1 MHz to 10 MHz away from the nominal frequency of the receiver;

for practical reasons the measurements shall be carried out at frequencies of the unwanted signal at approximately ± 1 MHz, ± 2 MHz, ± 5 MHz and ± 10 MHz, avoiding those frequencies at which spurious responses occur (see clause 8.6);

- b) initially, signal generator B (unwanted signal) shall be switched off (maintaining the output impedance);

the level of the wanted signal from generator A shall be adjusted to the level which is the value of the limit for the maximum usable sensitivity (i.e. 6 dB above 1 μ V emf under normal test conditions);

where possible, the receiver volume control shall be adjusted to give at least 50 % of the rated output power (see clause 6.11) or, in the case of stepped volume controls, to the first step that provides an output power of at least 50 % of the rated output power. The obtained audio output level shall be noted;

- c) the unwanted signal from generator B shall then be switched on;
- d) the level of generator B shall be adjusted so that the unwanted signal causes:
 - a reduction of 3 dB in the output level of the wanted signal; or
 - a reduction to 14 dB of the SINAD ratio at the receiver output (with a psophometric filter), whether or not measured acoustically;whichever occurs first;
- e) the level of the unwanted signal shall be noted;
- f) for each frequency, the blocking or desensitization shall be expressed as the level in dB μ V of the unwanted signal at the receiver for each frequency; this value shall be recorded;
- g) the measurement shall be repeated for all the frequencies defined in step a);
- h) the blocking or desensitization of the equipment under test shall be expressed as the lowest of the values recorded in step f).

8.8.2.2 Method of measurement (digital with continuous bit stream)

For digital equipment that supports adaptive rates, testing is only required at the maximum bit rate that the manufacturer declares is compliant to the present document.

The measurement procedure shall be as follows:

- a) two signal generators, A and B, shall be connected to the receiver via a combining network (see clause 6.9);
the wanted signal, provided by signal generator A, shall be at the nominal frequency of the receiver and shall be modulated by the test signal M2 (see clause 6.1.3);
the unwanted signal, provided by signal generator B, shall be unmodulated and shall be at a frequency from 1 MHz to 10 MHz away from the nominal frequency of the receiver;
for practical reasons the measurements shall be carried out at frequencies of the unwanted signal at approximately ± 1 MHz, ± 2 MHz, ± 5 MHz and ± 10 MHz, avoiding those frequencies at which spurious responses could occur (see clause 8.6);
- b) initially, signal generator B (unwanted signal) shall be switched off (maintaining the output impedance);
the level of the wanted signal from generator A shall be adjusted to the level which is 3 dB above the relevant limit in clause 8.3.3, at the receiver input terminals;
- c) signal generator B shall then be switched on, and the level of the unwanted signal adjusted until a bit error ratio of 10^{-1} or worse is obtained;
- d) the test signal M2 shall be transmitted whilst observing the bit error ratio;
- e) the level of the unwanted signal shall be reduced in steps of 1 dB until a bit error ratio of 10^{-2} or better is obtained. The level of the unwanted signal shall then be noted;
- f) for each frequency, the blocking or desensitization shall be expressed as the level in dB μ V of the unwanted signal at the receiver for each frequency; this value shall be recorded;
- g) the measurement shall be repeated for all the frequencies defined in step a);
- h) the blocking or desensitization of the equipment under test shall be expressed as the lowest of the values recorded in step f).

8.8.2.3 Method of measurement with messages

For digital equipment that supports adaptive rates, testing is only required at the maximum bit rate that the manufacturer declares is compliant to the present document.

In the case where operation using a continuous bit stream is not possible, the following method of measurement shall be applied.

The measurement procedure shall be as follows:

- a) two signal generators, A and B, shall be connected to the receiver via a combining network (see clause 6.9);
the wanted signal, provided by signal generator A, shall be at the nominal frequency of the receiver and shall have test signal M6 (see clause 6.1.3);
the unwanted signal, provided by signal generator B, shall be unmodulated and shall be at a frequency from 1 MHz to 10 MHz away from the nominal frequency of the receiver;
for practical reasons the measurements shall be carried out at frequencies of the unwanted signal at approximately ± 1 MHz, ± 2 MHz, ± 5 MHz and ± 10 MHz, avoiding those frequencies at which spurious responses could occur (see clause 8.6);
- b) initially, signal generator B (unwanted signal) shall be switched off (maintaining the output impedance);
the level of the wanted signal from generator A shall be adjusted to the level which is 3 dB above the relevant limit or manufacturer's declaration in clause 8.3.3, at the receiver input terminals;
- c) signal generator B shall then be switched on, and the level of the unwanted signal adjusted until a successful message ratio of less than 10 % is obtained;
- d) the test signal M6 (see clause 6.1.3) shall then be transmitted repeatedly whilst observing in each case whether or not a message is successfully received;
the level of the unwanted signal shall be reduced by 2 dB for each occasion that a message is not successfully received;
the procedure shall be continued until three consecutive messages are successfully received. The level of the input signal shall then be noted;
- e) the level of the unwanted signal shall be increased by 1 dB and the new value noted;
the normal test signal (see clause 7.3) shall then be transmitted 20 times. In each case, if a message is not successfully received the level of the unwanted signal shall be reduced by 1 dB and the new value noted;
if a message is successfully received, the level of the unwanted signals shall not be changed until three consecutive messages have been successfully received. In this case the unwanted signal shall be increased by 1 dB and the new value noted;
no level of the unwanted signal shall be noted unless preceded by a change in level;
the average of the values noted in steps d) and e) (which provides the level corresponding to the successful message ratio of 80 %) shall be noted;
for each frequency, the blocking or desensitization shall be expressed as the level in dB μ V of the unwanted signal at the receiver for each frequency; this value shall be recorded;
- f) the measurement shall be repeated for all the frequencies defined in step a);
- g) the blocking or desensitization of the equipment under test shall be expressed as the lowest of the values recorded in step f).

8.8.3 Limit

The blocking level, for any frequency within the specified ranges, shall not be less than 90,0 dB μ V except at frequencies on which spurious responses are found, clause 8.6.

8.9 Spurious radiations

8.9.1 Definition

Spurious radiations from the receiver are components at any frequency, radiated by the equipment and antenna.

For equipment with an external 50 Ω antenna connector, the level of spurious radiations are considered to be either:

- a) their power level in a specified load (conducted spurious emission); and
- b) their effective radiated power when radiated by the cabinet and structure of the equipment (cabinet radiation).

For equipment without an external antenna connector, spurious radiations are considered to be:

- c) their effective radiated power when radiated by the cabinet and the integral antenna, in the case of handportable equipment fitted with such an antenna and no external RF connector.

8.9.2 Methods of measurement

8.9.2.1 Method of measuring the power level in a specified load (clause 8.9.1 a))

For digital equipment that supports adaptive rates, testing is only required at the maximum bit rate that the manufacturer declares is compliant to the present document.

This method applies only to equipment with an external 50 Ω antenna connector.

Spurious radiations shall be measured as the power level of any discrete signal at the input terminals of the receiver. The receiver input terminals are connected to a spectrum analyser or selective voltmeter having an input impedance of 50 Ω and the receiver switched on.

If the detecting device is not calibrated in terms of power input, the level of any detected components shall be determined by a substitution method using a signal generator.

The measurements shall extend over the frequency range 9 kHz to 4 GHz for equipment operating on frequencies not exceeding 470 MHz or over the frequency range 9 kHz to 12,75 GHz for equipment operating on frequencies above 470 MHz.

At each frequency at which a spurious component is detected, the power level shall be recorded as the spurious level delivered into the specified load.

8.9.2.2 Method of measuring the effective radiated power (clause 8.9.1 b))

For digital equipment that supports adaptive rates, testing is only required at the maximum bit rate that the manufacturer declares is compliant to the present document.

This method applies only to equipment having an external antenna connector.

The measurement procedure shall be as follows:

- a) a test site which fulfils the requirements for the specified frequency range of this measurement shall be used (see annex A);
the equipment shall be placed at the specified height on a non-conducting support and in the position closest to normal use as declared by the manufacturer;
- b) the receiver antenna connector shall be connected to an artificial antenna (see clause 6.2):
 - the test antenna shall be orientated for vertical polarization and the length of the test antenna shall be chosen to correspond to the instant frequency of the measuring receiver;
 - the output of the test antenna shall be connected to a measuring receiver;

- c) radiation of any spurious components shall be detected by the test antenna and receiver, over the frequency range 30 MHz to 4 GHz. For equipment operating on frequencies above 470 MHz the measurements shall also be performed over the frequency range 4 GHz to 12,75 GHz if emissions are detected within 10 dB of the of the specified limit between 1,5 GHz and 4 GHz;
- d) at each frequency at which a component is detected the test antenna shall be raised and lowered through the specified range of height until a maximum signal level is detected by the measuring receiver;
when a test site according to clause A.1.1 is used, there is no need to vary the height of the antenna;
- e) the receiver shall then be rotated through 360 ° in the horizontal plane until the maximum signal level detected by the measuring receiver;
the maximum signal level detected by the measuring receiver shall be noted;
- f) the receiver shall be replaced by a substitution antenna as defined in clause A.1.5;
the substitution antenna shall be orientated for vertical polarization and the length of the substitution antenna shall be adjusted to correspond to the frequency of the spurious component detected;
- g) the substitution antenna shall be connected to a calibrated signal generator;
the frequency of the calibrated signal generator shall be set to the frequency of the spurious component detected;
- h) the input attenuator setting of the measuring receiver shall be adjusted in order to increase the sensitivity of the measuring receiver if necessary;
- i) the test antenna shall be raised and lowered through the specified range of height to ensure that the maximum signal is received;
the input signal to the substitution antenna shall be adjusted to the level that produces a level detected by the measuring receiver, that is equal to the level noted while the spurious component was measured, corrected for the change of input attenuator setting of the measuring receiver;
the input level of the substitution antenna shall be recorded as a power level, corrected for the change of input attenuator setting of the measuring receiver;
- j) the measurement shall be repeated with the test antenna and the substitution antenna orientated for horizontal polarization;
- k) the measure of the effective radiated power of the spurious components is the larger of the two power levels recorded for each spurious component at the input to the substitution antenna, corrected for the gain of the antenna if necessary.

8.9.2.3 Method of measuring the effective radiated power (clause 8.9.1 c))

For digital equipment that supports adaptive rates, testing is only required at the maximum bit rate that the manufacturer declares is compliant to the present document.

This method applies only to equipment without an external antenna connector.

The method of measurement shall be performed according to clause 8.9.2.2, except that the equipment and its antenna shall be mounted in a normal installation in its normal operating position.

8.9.3 Limits

The power of any spurious radiations shall not exceed the values given in tables 8 and 9.

Table 8: Conducted components

Frequency range	9 kHz to 1 GHz	Above 1 GHz to 4 GHz, or above 1 GHz to 12,75 GHz, (see clause 8.9.2)
Limit	2,0 nW (-57,0 dBm)	20,0 nW (-47,0 dBm)

Table 9: Radiated components

Frequency range	30 MHz to 1 GHz	Above 1 GHz to 4 GHz or above 1 GHz to 12,75 GHz (see clause 8.9.2.2)
Limit	2,0 nW (-57,0 dBm)	20,0 nW (-47,0 dBm)

In the case of radiated measurements for handportable stations the following conditions apply:

- internal integral antenna: the normal antenna shall be connected;
- external antenna connector: an artificial load shall be connected to the connector for the test.

Table 10: Reference bandwidths to be used for the measurement of spurious radiations

Frequency range	RBW
9 kHz to 150 kHz	1 kHz
150 kHz to 30 MHz	10 kHz
30 MHz to 1 GHz	100 kHz
1 GHz to 12,75 GHz	1 MHz

8.10 Co-channel rejection

For digital equipment that supports adaptive rates, testing is only required at two bit rates, the minimum bit rate supported by the equipment and the maximum bit rate that the manufacturer declares is compliant to the present document.

8.10.1 Definition

8.10.2 Methods of measurement

8.10.2.1 Method of measurement (analogue)

The measurement procedure shall be as follows:

- a) two signal generators, A and B, shall be connected to the receiver via a combining network (see clause 6.9);
the wanted signal, provided by signal generator A, shall be at the nominal frequency of the receiver and shall have receiver analogue test modulation, (see clause 6.1.2);
the unwanted signal, provided by signal generator B, shall be modulated test signal M4 (see clause 6.1.3) and shall also be at the nominal frequency of the receiver;

- b) initially, signal generator B (unwanted signal) shall be switched off (maintaining the output impedance);
- the level of the wanted signal from generator A shall be adjusted to a level which is 20 dB above the value of the limit for the maximum usable sensitivity (i.e. 26 dB above 1 μ V emf under normal test conditions);
- where possible, the receiver volume control shall be adjusted to give at least 50 % of the rated output power (clause 6.11) or, in the case of stepped volume controls, to the first step that provides an output power of at least 50 % of the rated output power. The obtained audio output level shall be noted;
- c) the unwanted signal from generator B shall then be switched on;
- d) the level of generator B shall be adjusted so that the unwanted signal causes:
- a reduction of 3 dB in the output level of the wanted signal; or
 - a reduction to 14 dB of the SINAD ratio at the receiver output (with a psophometric filter), whether or not measured acoustically;
- whichever occurs first;
- e) the level of the unwanted signal shall be noted;
- f) for each frequency of the unwanted signal, the co-channel rejection ratio shall be expressed as the ratio, in dB, of the level of the unwanted signal to the level of the wanted signal, at the receiver input. This ratio shall be recorded;
- g) the measurement shall be repeated for displacements of the unwanted signal of ± 12 % of the CSP;
- h) the co-channel rejection ratio of the equipment under test shall be expressed as the lowest of the three values expressed in dB, calculated in step f).

The value of the co-channel rejection ratio, expressed in dB, is generally negative (therefore, for example, -12 dB is lower than -8 dB).

8.10.2.2 Method of measurement (digital with continuous bit stream)

For digital equipment that supports adaptive rates, testing is only required at two bit rates, the minimum bit rate supported by the equipment and the maximum bit rate that the manufacturer declares is compliant to the present document.

The measurement procedure shall be as follows:

- a) two signal generators, A and B, shall be connected to the receiver via a combining network (clause 6.9);
- the wanted signal, provided by signal generator A, shall be at the nominal frequency of the receiver and shall be modulated by the test signal M2 (clause 6.1.3);
- the unwanted signal, provided by signal generator B, shall be modulated test signal M4 (clause 6.1.3) and shall also be at the nominal frequency of the receiver;
- b) initially, signal generator B (unwanted signal) shall be switched off (maintaining the output impedance);
- the level of the wanted signal from generator A shall be adjusted to the level which is 20 dB above the relevant limit in clause 8.3.3, at the receiver input terminals;
- c) signal generator B shall then be switched on, and the level of the unwanted signal adjusted until a bit error ratio of 10^{-1} or worse is obtained;
- d) the test signal M2 shall be transmitted whilst observing the bit error ratio;
- e) the level of the unwanted signal shall be reduced in steps of 1 dB until a bit error ratio of 10^{-2} or better is obtained. The level of the unwanted signal shall then be noted;
- f) for each frequency of the unwanted signal, the co-channel rejection ratio shall be expressed as the ratio, in dB, of the level of the unwanted signal to the level of the wanted signal, at the receiver input. This ratio shall be recorded;

- g) the measurement shall be repeated for displacements of the unwanted signal of ± 12 % of the CSP;
- h) the co-channel rejection ratio of the equipment under test shall be expressed as the lowest of the three values expressed in dB, calculated in step f).

The value of the co-channel rejection ratio, expressed in dB, is generally negative (therefore, for example, -12 dB is lower than -8 dB).

8.10.2.3 Method of measurement with messages

In the case where operation using a continuous bit stream is not possible, the following method of measurement shall be applied.

For digital equipment that supports adaptive rates, testing is only required at two bit rates, the minimum bit rate supported by the equipment and the maximum bit rate that the manufacturer declares is compliant to the present document.

The measurement procedure shall be as follows:

- a) two signal generators, A and B, shall be connected to the receiver via a combining network (see clause 6.9);
the wanted signal, provided by signal generator A, shall be at the nominal frequency of the receiver and shall have test signal M6 (see clause 6.1.3);
the unwanted signal, provided by signal generator B, shall be modulated test signal M4 (see clause 6.1.3) and shall also be at the nominal frequency of the receiver;
- b) initially, signal generator B (unwanted signal) shall be switched off (maintaining the output impedance);
the level of the wanted signal from generator A shall be adjusted to the level which is 20 dB above the relevant limit or manufacturer's declaration in clause 8.3.3, at the receiver input terminals;
- c) signal generator B shall then be switched on, and the level of the unwanted signal adjusted until a successful message ratio of less than 10 % is obtained;
- d) the test signal M6 (see clause 6.1.3) shall then be transmitted repeatedly whilst observing in each case whether or not a message is successfully received;
the level of the unwanted signal shall be reduced by 2 dB for each occasion that a message is not successfully received;
the procedure shall be continued until three consecutive messages are successfully received. The level of the input signal shall then be noted;
- e) the level of the unwanted signal shall be increased by 1 dB and the new value noted;
the normal test signal (see clause 7.3) shall then be transmitted 20 times. In each case, if a message is not successfully received the level of the unwanted signal shall be reduced by 1 dB and the new value noted;
if a message is successfully received, the level of the unwanted signals shall not be changed until three consecutive messages have been successfully received. In this case the unwanted signal shall be increased by 1 dB and the new value noted;
no level of the unwanted signal shall be noted unless preceded by a change in level;
the average of the values noted in steps d) and e) (which provides the level corresponding to the successful message ratio of 80 %) shall be noted;
- f) for each frequency of the unwanted signal, the co-channel rejection ratio shall be expressed as the ratio, in dB, of the level of the unwanted signal to the level of the wanted signal, at the receiver input. This ratio shall be recorded;
- g) the measurement shall be repeated for displacements of the unwanted signal of ± 12 % of the CSP;
- h) the co-channel rejection ratio of the equipment under test shall be expressed as the lowest of the three values expressed in dB, calculated in step f).

The value of the co-channel rejection ratio, expressed in dB, is generally negative (therefore, for example, -12 dB is lower than -8 dB).

8.10.3 Limits

The value of co-channel rejection ratio shall be:

- greater than -15 dB for analogue tests;
- greater than -12 dB for equipment operating with data rates of up to 2 400 bits per second;
- greater than -15 dB for equipment operating with data rates between 2 401 bits per second and 4 800 bits per second;
- greater than -18 dB for equipment operating with data rates between 4 801 bits per second and 9 600 bits per second;
- greater than -24 dB for equipment operating with data rates greater than 9 600 bits per second.

9 Duplex operation

9.1 Receiver desensitization (with simultaneous transmission and reception)

9.1.1 Definition

The desensitization is the degradation of the sensitivity of the receiver resulting from some power from the transmitter coupling into the receiver. The desensitization is expressed as the difference in dB between the maximum usable sensitivity levels with and without simultaneous transmissions.

9.1.2 Methods of measurement

9.1.2.1 Desensitization measured with analogue modulation

9.1.2.1.1 Method of measurement when the equipment has a duplex filter

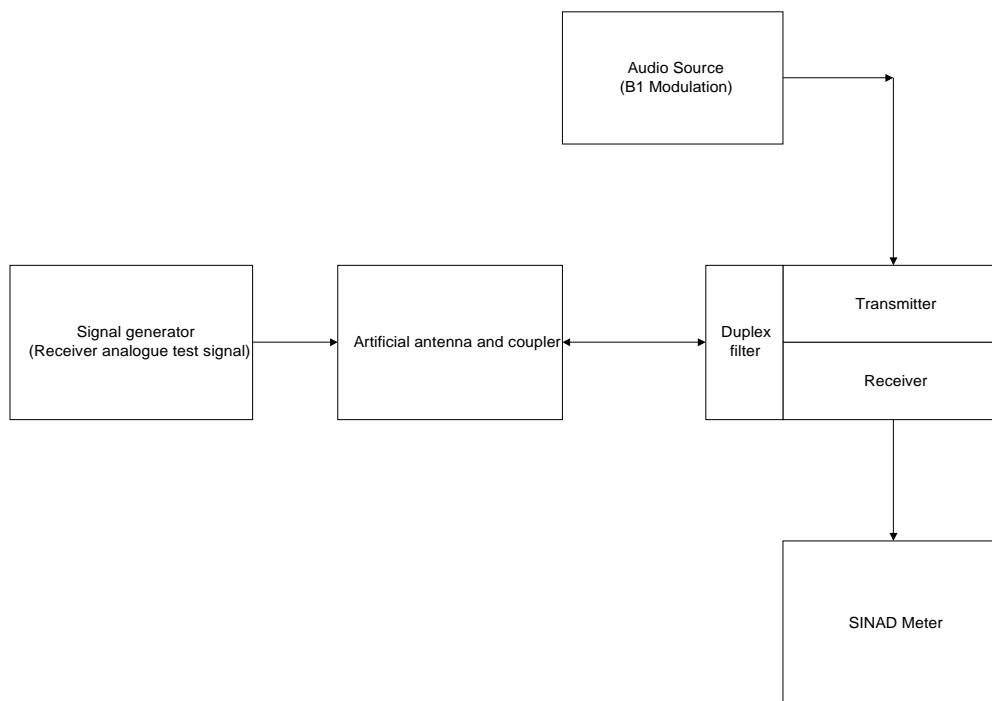

Figure 7: Measurement arrangement

The measurement procedure shall be as follows:

- a) the antenna connector of the equipment shall be connected to a power attenuator giving sufficient protection to the devices connected to the power attenuator output;

a signal generator modulated by the receiver analogue test signal (see clause 6.1.2), shall be connected to the power attenuator so that it does not affect the impedance matching and does not generate intermodulation products which could impair the results of the measurement;
- b) the transmitter shall be brought into operation at the output power as defined in clause 7.1, modulated by the test signal B1 (see clause 6.1.1);

the receiver sensitivity (analogue, conducted) shall then be measured in accordance with clause 8.1.2;
- c) the output level of the signal generator shall be noted as C in dB relative to an emf of 1 μV ;
- d) the transmitter shall then be switched off and the receiver sensitivity (analogue, conducted, see clause 8.1.2) is measured again;
- e) the output level of the signal generator shall be noted as D in dB relative to an emf of 1 μV ;
- f) the desensitization is the difference between the values of C and D in dB.

9.1.2.1.2 Method of measurement when the equipment has to operate with two antennas

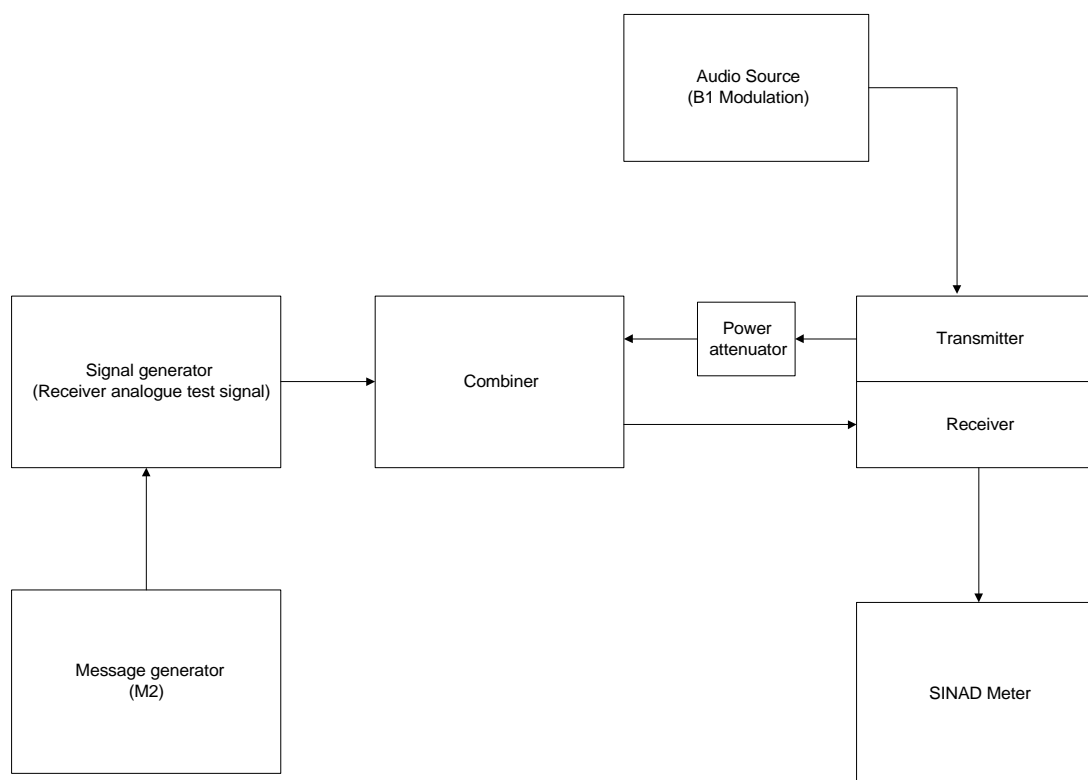

Figure 8: Measurement arrangement

The measurement procedure shall be as follows:

- a) the transmitter shall be connected to a power attenuator the output of which is fed to the receiver via a combiner;

the total attenuation of the power attenuator and the combiner shall be 30 dB, which is intended to simulate a corresponding antenna isolation;

if an external filter at the transmitter output or an external filter at the receiver input or both are part of the normal operation arrangement, this or these filters shall be included in the measurement arrangement accordingly;

a signal generator modulated by the receiver analogue test signal (see clause 6.1.2) shall be connected to the combiner in such a way as not to affect the impedance matching and does not generate intermodulation products which could impair the results of the measurement;
- b) the transmitter shall be brought into operation with an output power as defined in clause 7.1, modulated by the test signal B1 (see clause 6.1.1);

the receiver sensitivity (analogue, conducted) shall then be measured in accordance with clause 8.1.2;
- c) the output level of the signal generator shall be noted as C in dB relative to an emf of 1 μ V;
- d) the transmitter shall then be switched off and the receiver sensitivity (analogue, conducted) measured again;
- e) the output level of the signal generator shall be noted as D in dB relative to an emf of 1 μ V;
- f) the desensitization is the difference between the values of C and D in dB.

9.1.2.2 Desensitization measured with continuous bit streams

9.1.2.2.1 Method of measurement when the equipment has a duplex filter

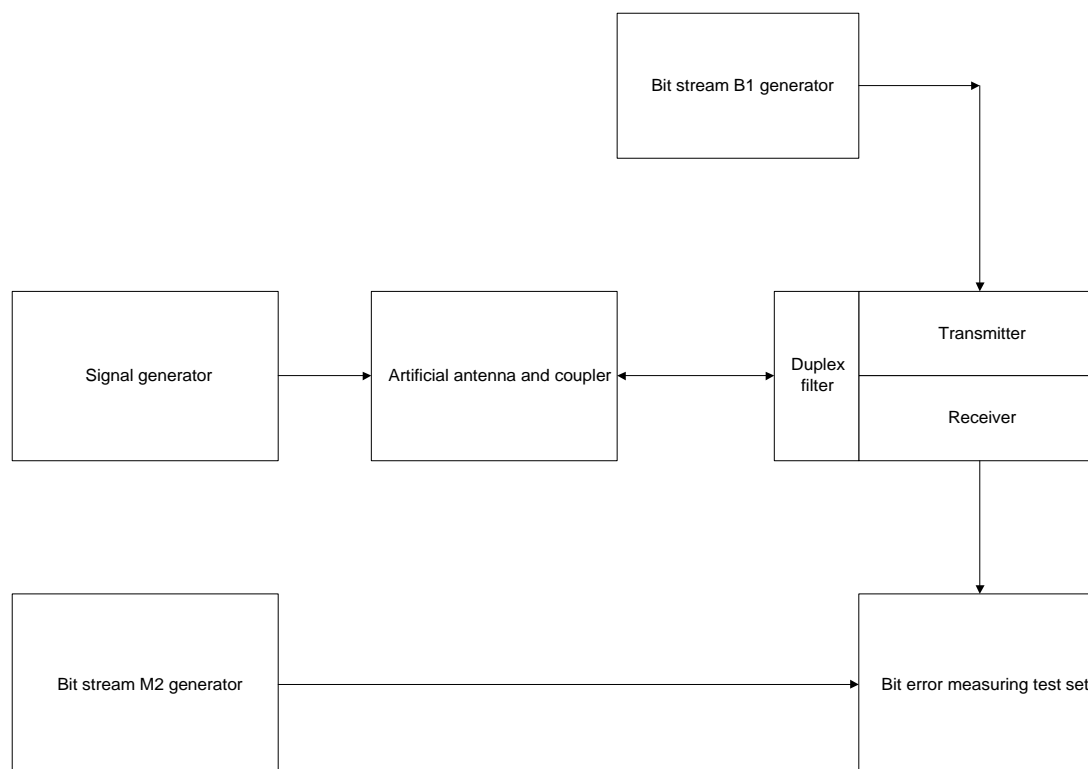

Figure 9: Measurement arrangement

The measurement procedure shall be as follows:

- a) the antenna connector of the equipment shall be connected to a power attenuator giving sufficient protection to the devices connected to the power attenuator output;

a signal generator modulated by the test signal M2 (see clause 6.1.3), shall be connected to the power attenuator so that it does not affect the impedance matching and does not generate intermodulation products which could impair the results of the measurement;
- b) the transmitter shall be brought into operation at the output power as defined in clause 7.1, modulated by the test signal M5 (see clause 6.1.1);

the pseudo-random bit sequence used in signal M5 shall be uncorrelated with the one used in test signal M2 in step a);

the receiver sensitivity (data, conducted) shall then be measured in accordance with clause 8.3.2.1;
- c) the output level of the signal generator shall be noted as C in dB relative to an emf of 1 μ V;
- d) the transmitter shall then be switched off and the receiver sensitivity (data, conducted, clause 8.3.2.1) is measured again;
- e) the output level of the signal generator shall be noted as D in dB relative to an emf of 1 μ V;
- f) the desensitization is the difference between the values of C and D in dB.

9.1.2.2.2 Method of measurement when the equipment has to operate with two antennas

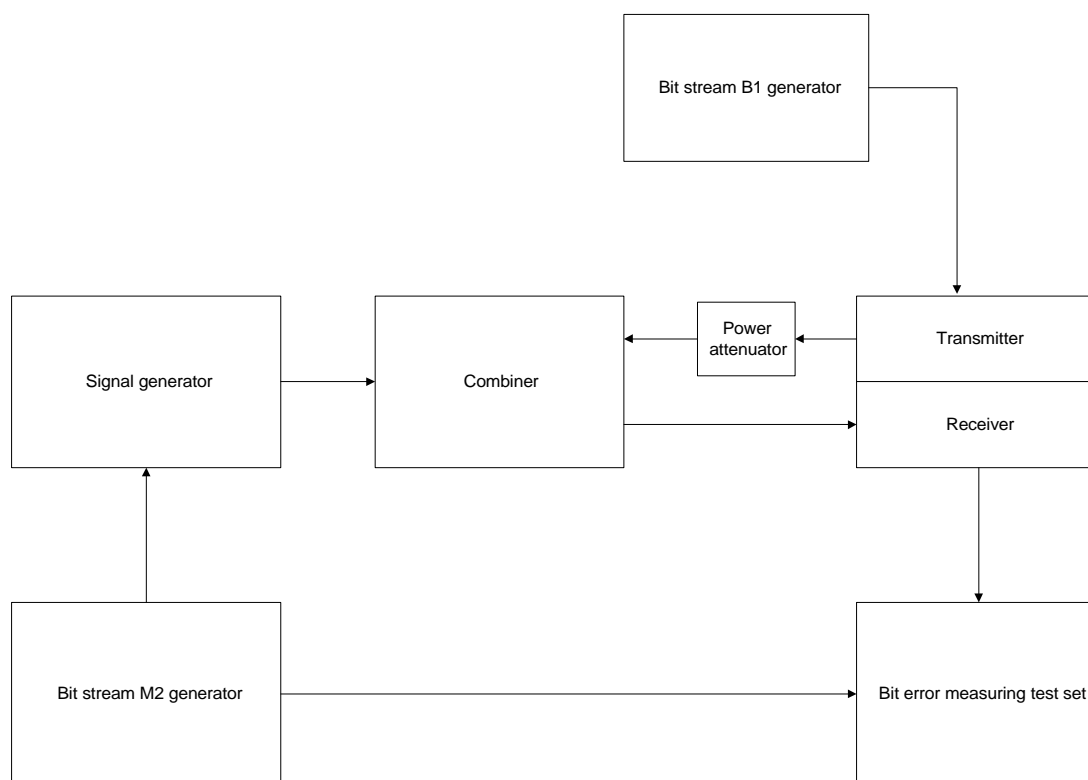

Figure 10: Measurement arrangement

The measurement procedure shall be as follows:

- a) the transmitter shall be connected to a power attenuator the output of which is fed to the receiver via a combiner;

the total attenuation of the power attenuator and the combiner shall be 30 dB, which is intended to simulate a corresponding antenna isolation;

if an external filter at the transmitter output or an external filter at the receiver input or both are part of the normal operation arrangement, this or these filters shall be included in the measurement arrangement accordingly;

a signal generator modulated by the test signal M2 (see clause 6.1.3) shall be connected to the combiner in such a way as not to affect the impedance matching and does not generate intermodulation products which could impair the results of the measurement;
- b) the transmitter shall be brought into operation with an output power as defined in clause 7.1, modulated by the test signal M5 (see clause 6.1.1);

the pseudo-random bit sequence used in signal M5 shall be uncorrelated with the one used in test signal M2 in step a);

the receiver sensitivity (data, conducted) shall then be measured in accordance with clause 8.3.2.1;
- c) the output level of the signal generator shall be noted as C in dB relative to an emf of 1 μ V;
- d) the transmitter shall then be switched off and the receiver sensitivity (data, conducted) measured again;
- e) the output level of the signal generator shall be noted as D in dB relative to an emf of 1 μ V;
- f) the desensitization is the difference between the values of C and D in dB.

9.1.2.3 Desensitization measured with messages

9.1.2.3.1 Method of measurement when the equipment has a duplex filter

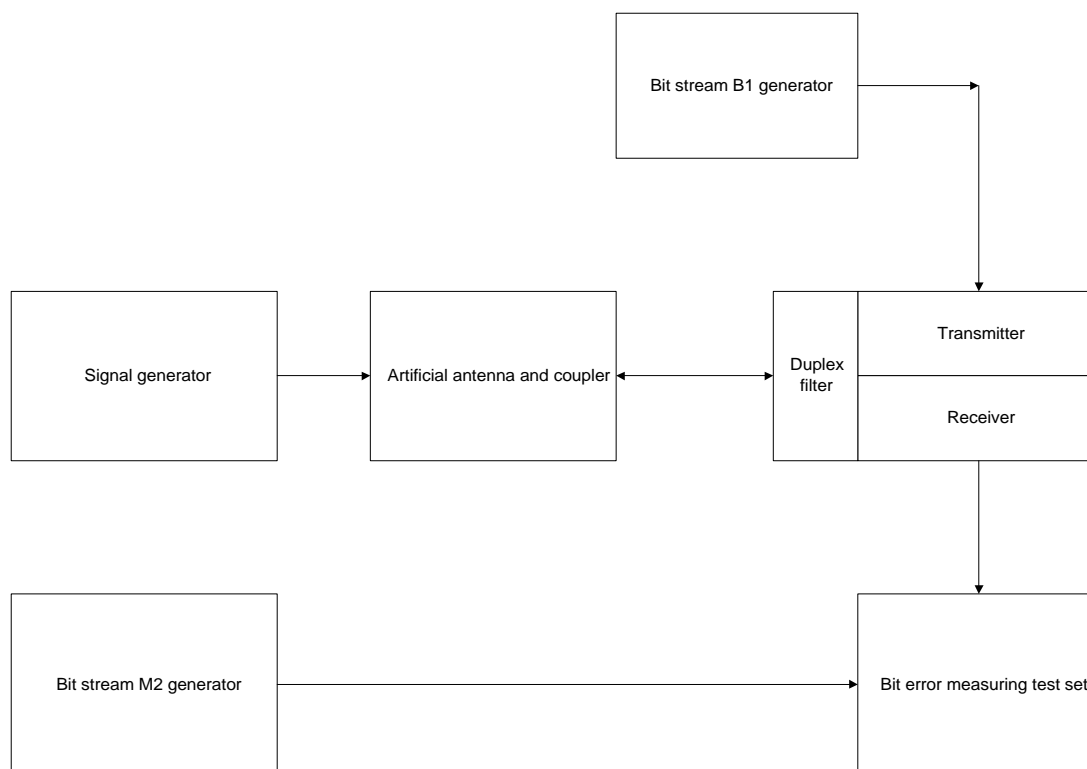

Figure 11: Measurement arrangement

The measurement procedure shall be as follows:

- a) the antenna connector of the equipment shall be connected to a power attenuator giving sufficient protection to the devices connected to the power attenuator output;
 a signal generator having test modulation M6 (see clauses 6.1.3 and 6.4) shall be connected to the power attenuator so that it does not affect the impedance matching and does not generate intermodulation products which could impair the results of the measurement;
- b) the transmitter shall be brought into operation with an output power as defined in clause 7.1, and shall be modulated by test signal M7, using a message different from the message used in step a);
 the receiver sensitivity (messages, conducted) shall then be measured in accordance with clause 8.3.2.2;
- c) the output level of the signal generator shall be noted as C in dB relative to an emf of 1 μ V;
- d) the transmitter shall then be switched off and the receiver sensitivity (messages, conducted) measured again;
- e) the output level of the signal generator shall be noted as D in dB relative to an emf of 1 μ V;
- f) the desensitization is the difference between the values of C and D in dB.

9.1.2.3.2 Method of measurement when the equipment has to operate with two antennas

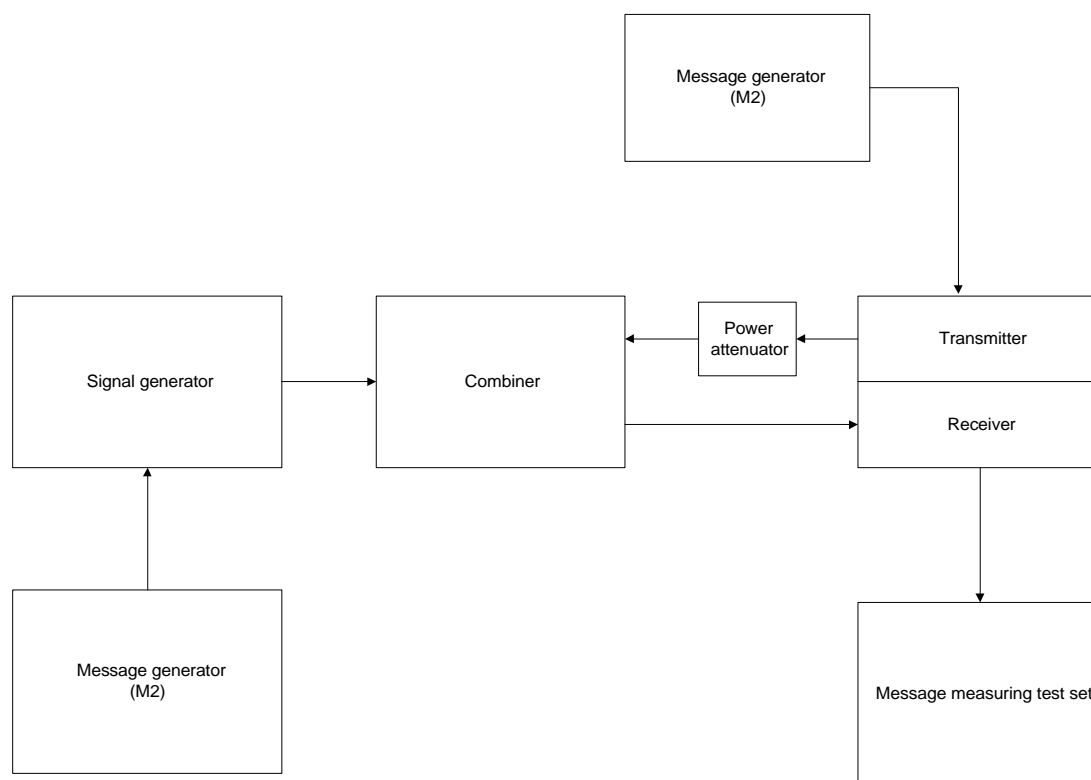

Figure 12: Measurement arrangement

The measurement procedure shall be as follows:

- a) the transmitter shall be connected to a power attenuator the output of which is fed to the receiver via a combiner;

the total attenuation of the power attenuator and the combiner shall be 30 dB, which is intended to simulate a corresponding antenna isolation;

if an external filter at the transmitter output or an external filter at the receiver input or both are part of the normal operation arrangement, this or these filters shall be included in the measurement arrangement accordingly;

a signal generator having test modulation M6 (see clauses 6.1.3 and 6.4) shall be connected to the combiner so that it does not affect the impedance matching and does not generate intermodulation products which could impair the results of the measurement;

- b) the transmitter shall be brought into operation with an output power as defined in clause 7.1, and shall be modulated by test signal M7, using a message different from the message used in step a);

the receiver sensitivity (messages, conducted) shall then be measured in accordance with clause 8.3.2.2;

- c) the output level of the signal generator shall be noted as C in dB relative to an emf of 1 μ V;
- d) the transmitter shall then be switched off and the receiver sensitivity (messages, conducted) measured again;
- e) the output level of the signal generator shall be noted as D in dB relative to an emf of 1 μ V;
- f) the desensitization is the difference between the values of C and D in dB.

9.1.3 Limits

The desensitization shall not exceed 3,0 dB.

The limit of maximum usable sensitivity measured in clauses 8.1.2 and 8.1.3 under normal test conditions shall exceed the specified limits in clauses 8.1.3 and 8.3.3 by an amount not less than the measured desensitization in the relevant clause 9.1.2.

9.2 Receiver spurious response rejection (with simultaneous transmission and reception)

9.2.1 Definition

The spurious response rejection, under duplex operation, is a measure of the capability of the receiver to achieve a specific spurious response rejection ratio when receiving a wanted modulated signal in the presence of:

- a) an unwanted signal at any other frequency, at which a response may be obtained; and
- b) the signal of the transmitter operating at duplex frequency distance, at the maximum output power and attenuated by the duplex filter and/or by the decoupling between the antennas.

9.2.2 Method of measurement

The receiver spurious response rejection under duplex operation shall be measured as specified in clause 8.6 with the measurement arrangements as shown in figures 13 to 18. The transmitter shall be operated at the maximum output power as defined in clause 7.1.

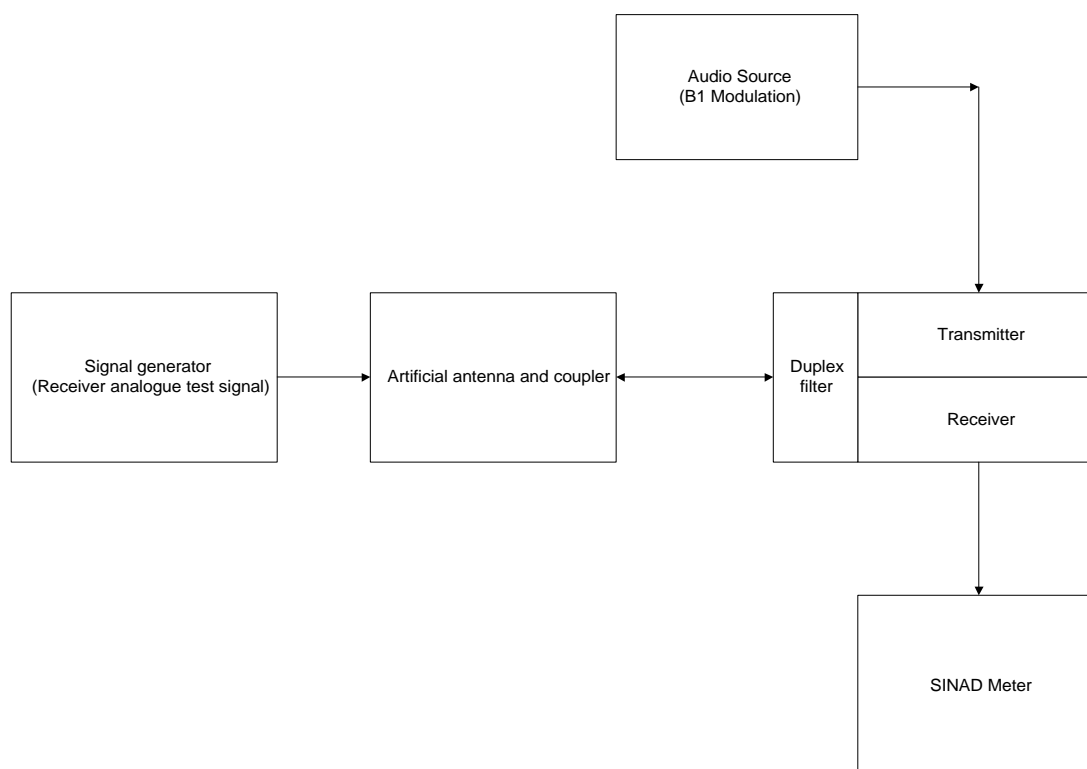

Figure 13: Measurement arrangement for analogue equipment with a duplex filter

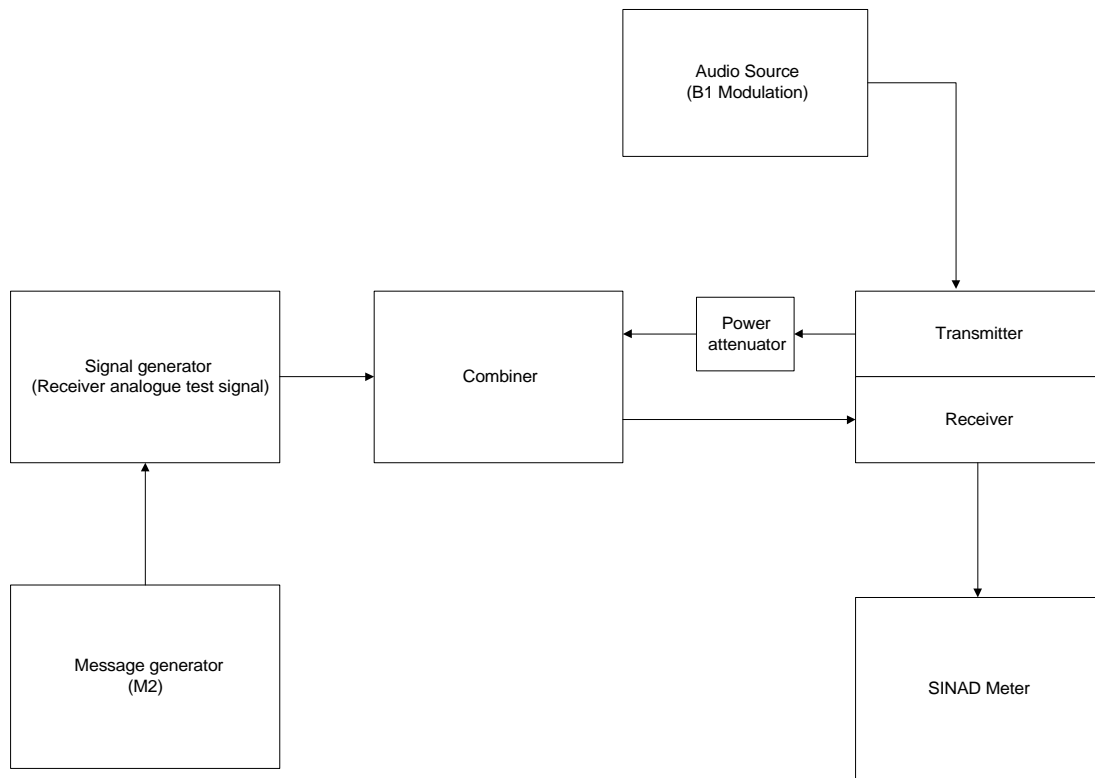

Figure 14: Measurement arrangement for analogue equipment with two antennas

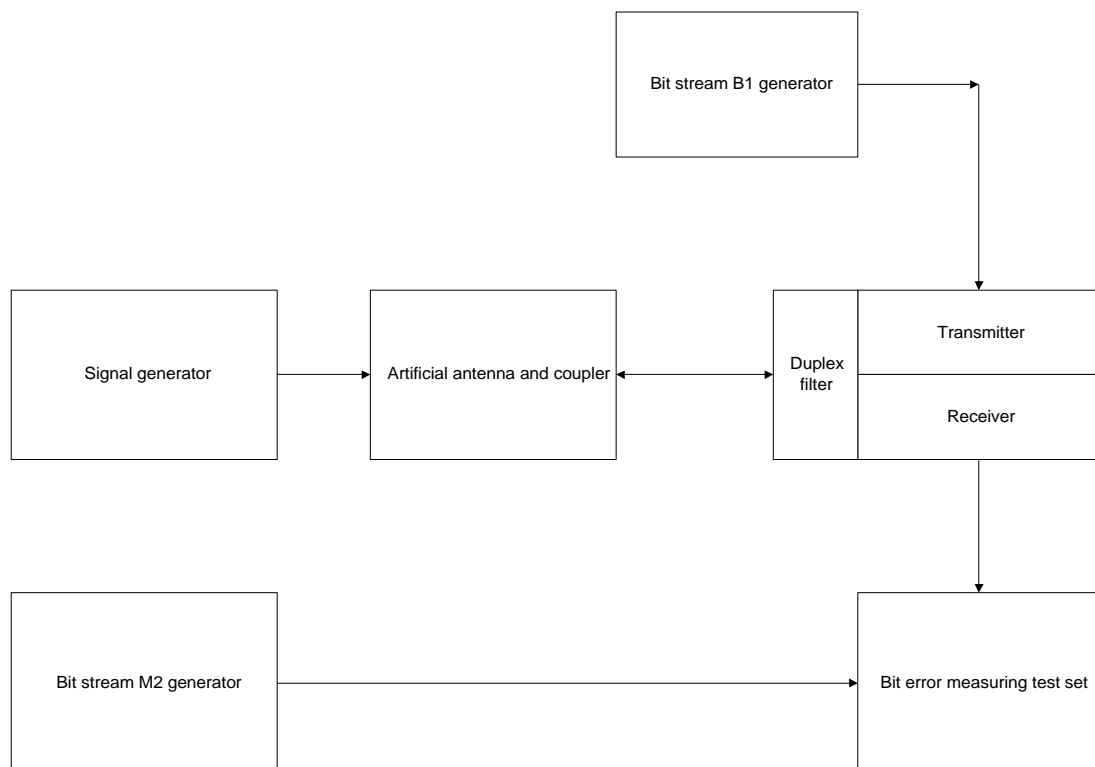

Figure 15: Measurement arrangement for digital equipment (continuous bit streams) having a duplex filter

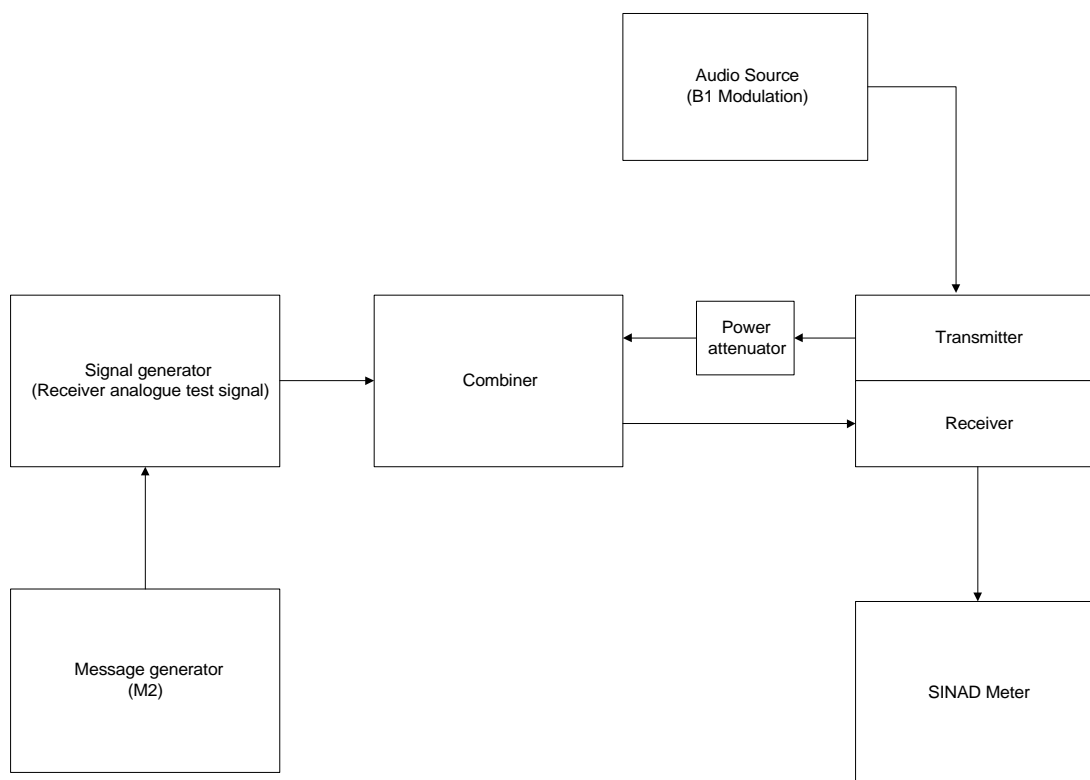

Figure 16: Measurement arrangement for digital equipment (continuous bit streams) having two antennas

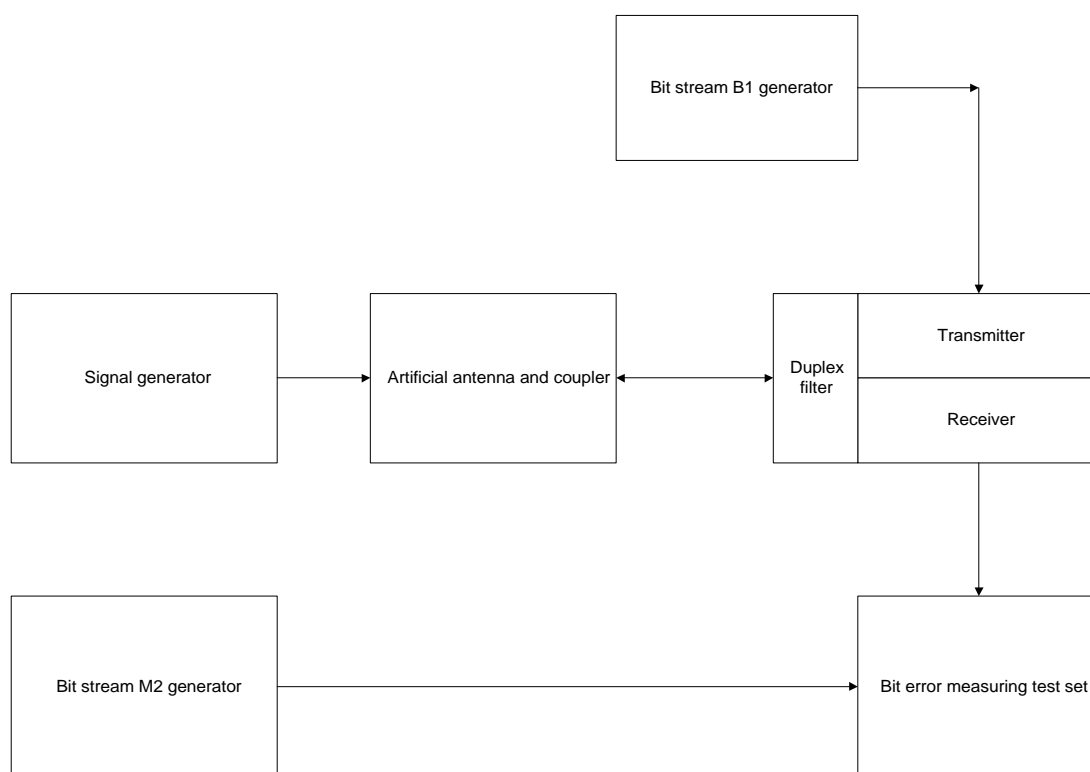

Figure 17: Measurement arrangement for digital equipment (messages) having a duplex filter

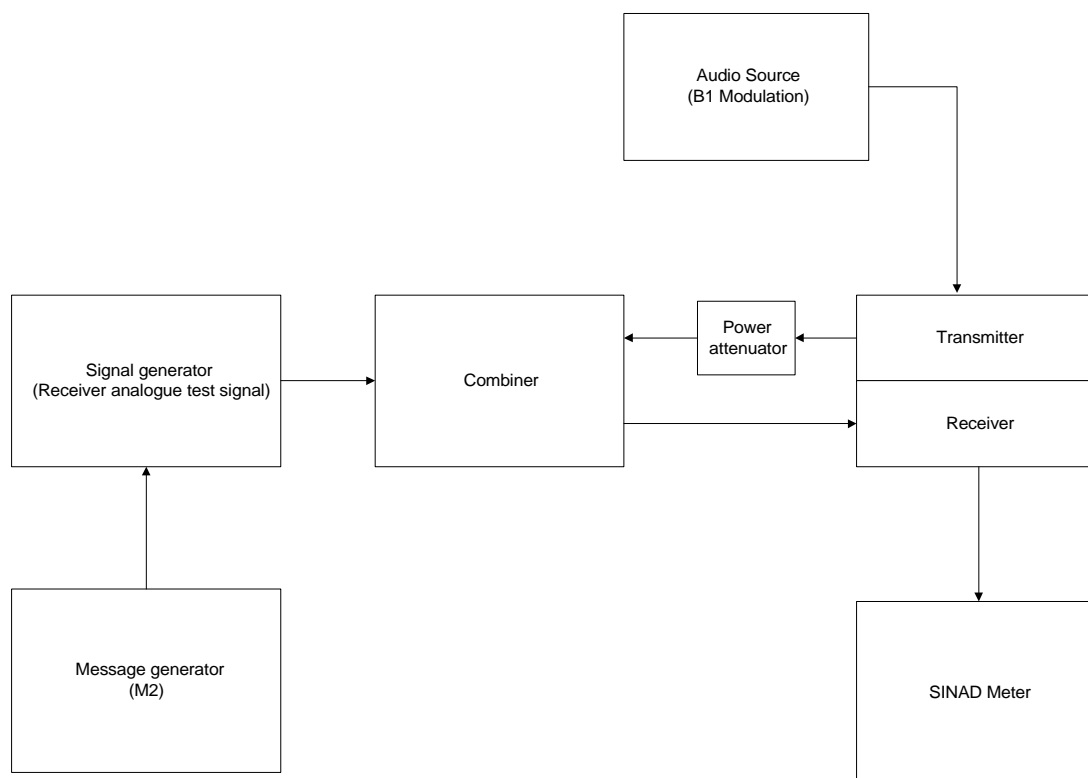

Figure 18: Measurement arrangement for digital equipment (messages) having two antennas

Spurious responses due to duplex operation (due to the active transmitter) are most likely to occur at frequencies f_{sd} derived from the following expressions:

$$- f_{sd} = | (f_r \pm p \times f_t) / q | \quad \text{and} \quad f_{sd} = | n \times f_t \pm f_{I1} |$$

where:

- f_t is the transmitter frequency;
- f_r is the receiver frequency; and
- f_{I1} is the first IF of the receiver;
- n, p, q are integers 1, 2, 3

Normally it is sufficient to make the measurement with the unwanted signal set only to the following particular frequencies f_m :

$$- f_m = (f_r + f_t) / 2 ; \quad f_m = 2 | f_r + f_t | ; \quad f_m = f_t + f_{I1} ; \quad f_m = | f_t - f_{I1} | .$$

NOTE: Particular attention should be paid to avoiding measurement errors which might be caused by intermodulation effects in the generators, especially in generator B which provides the unwanted signal. To avoid such errors, care needs to be taken to attenuate sufficiently the transmitter power entering the signal generators via the combining networks. For this purpose the measurement arrangements, illustrated in figures 13 to 18 recommend the insertion of isolators. The insertion of a stop band filter for the transmitter frequency may serve the same purpose.

9.2.3 Limits

At any frequency separated from the nominal frequency of the receiver by two channels or more, the spurious response rejection ratio shall be greater than 67,0 dB.

10 Measurement uncertainty

The interpretation of the results recorded in the test report for the measurements described in the present document shall be as follows:

- the measured value related to the corresponding limit shall be used to decide whether an equipment meets the requirements of the present document;
- the value of the measurement uncertainty for the measurement of each parameter shall be separately included in the test report;
- the value of the measurement uncertainty should be, for each measurement, equal to or lower than the figures in table 11.

Table 11: Measurement uncertainty

Parameter	Uncertainty
Radio Frequency	$\pm 1 \times 10^{-7}$
RF Power (up to 160 W)	$\pm 0,75$ dB
Radiated RF power	± 6 dB
Adjacent channel power	± 5 dB
Conducted spurious emission of transmitter. Valid up to 12,75 GHz	± 4 dB
Conducted spurious emission of receiver. Valid up to 12,75 GHz	± 7 dB
Two-signal measurement. Valid up to 4 GHz	± 4 dB
Three-signal measurement	± 3 dB
Radiated emission of the transmitter. Valid up to 4 GHz	± 6 dB
Radiated measurement of receiver. Valid up to 4 GHz	± 6 dB
Transmitter attack time	± 20 %
Transmitter release time	± 20 %
Transmitter transient frequency (frequency difference)	± 250 Hz
Transmitter intermodulation	± 3 dB
Receiver desensitization (duplex operation)	$\pm 0,5$ dB
Temperature	± 1 ° C
Humidity	± 10 %
Valid up to 1 GHz for the RF parameters unless otherwise stated.	

For the test methods, according to the present document the uncertainty figures shall be calculated according to the principles of the methods described in TR 100 028 [i.1] and shall correspond to an expansion factor (coverage factor) $k = 1,96$ or $k = 2$ (which provide confidence levels of respectively 95 % and 95,45 % in case where the distributions characterizing the actual measurement uncertainties are normal (Gaussian)).

Table 11 is based on such expansion factors.

The particular expansion factor used for the evaluation of the measurement uncertainty shall be stated.

Annex A (normative): Radiated measurement

A.1 Test sites and general arrangements for measurements involving the use of radiated fields

This normative annex introduces three most commonly available test sites, an anechoic chamber, an anechoic chamber with a ground plane and an Open Area Test Site (OATS), which may be used for radiated tests. These test sites are generally referred to as free field test sites. Both absolute and relative measurements can be performed in these sites. Where absolute measurements are to be carried out, the chamber should be verified. A detailed verification procedure is described in TR 102 273 [i.2], relevant parts 2, 3 and 4.

NOTE: To ensure reproducibility and traceability of radiated measurements only these test sites should be used in test measurements.

A.1.1 Anechoic chamber

An anechoic chamber is an enclosure, usually shielded, whose internal walls, floor and ceiling are covered with radio absorbing material, normally of the pyramidal urethane foam type. The chamber usually contains an antenna support at one end and a turntable at the other. A typical anechoic chamber is shown in figure A.1.

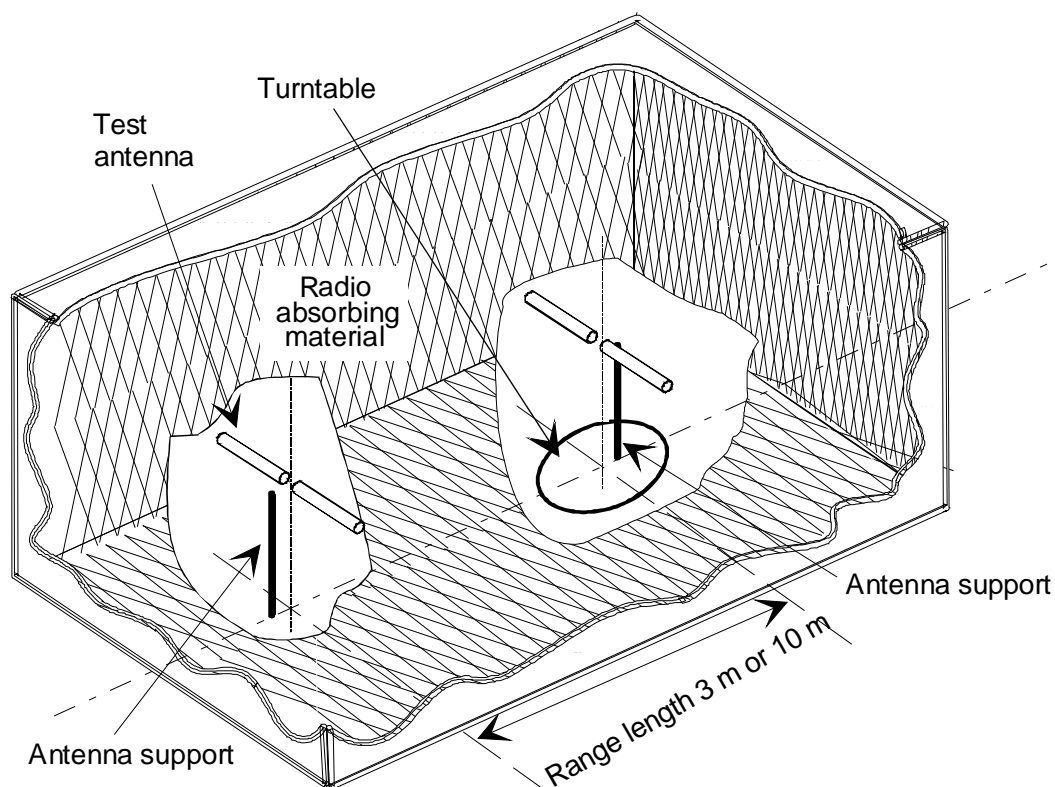

Figure A.1: A typical anechoic chamber

The chamber shielding and radio absorbing material work together to provide a controlled environment for testing purposes. This type of test chamber attempts to simulate free space conditions.

The shielding provides a test space, with reduced levels of interference from ambient signals and other outside effects, whilst the radio absorbing material minimizes unwanted reflections from the walls and ceiling which can influence the measurements. In practice it is relatively easy for shielding to provide high levels (80 dB to 140 dB) of ambient interference rejection, normally making ambient interference negligible.

A turntable is capable of rotation through 360° in the horizontal plane and it is used to support the test sample (EUT) at a suitable height (e.g. 1 m) above the ground plane. The chamber shall be large enough to allow the measuring distance of at least 3 m or $2(d_1+d_2)^2/\lambda$ (m), whichever is greater (see clause A.2.5). The distance used in actual measurements shall be recorded with the test results.

The anechoic chamber generally has several advantages over other test facilities. There is minimal ambient interference, minimal floor, ceiling and wall reflections and it is independent of the weather. It does however have some disadvantages which include limited measuring distance and limited lower frequency usage due to the size of the pyramidal absorbers. To improve low frequency performance, a combination structure of ferrite tiles and urethane foam absorbers is commonly used.

All types of emission, sensitivity and immunity testing can be carried out within an anechoic chamber without limitation.

A.1.2 Anechoic chamber with a ground plane

An anechoic chamber with a ground plane is an enclosure, usually shielded, whose internal walls and ceiling are covered with radio absorbing material, normally of the pyramidal urethane foam type. The floor, which is metallic, is not covered and forms the ground plane. The chamber usually contains an antenna mast at one end and a turntable at the other. A typical anechoic chamber with a ground plane is shown in figure A.2.

This type of test chamber attempts to simulate an ideal OATS whose primary characteristic is a perfectly conducting ground plane of infinite extent.

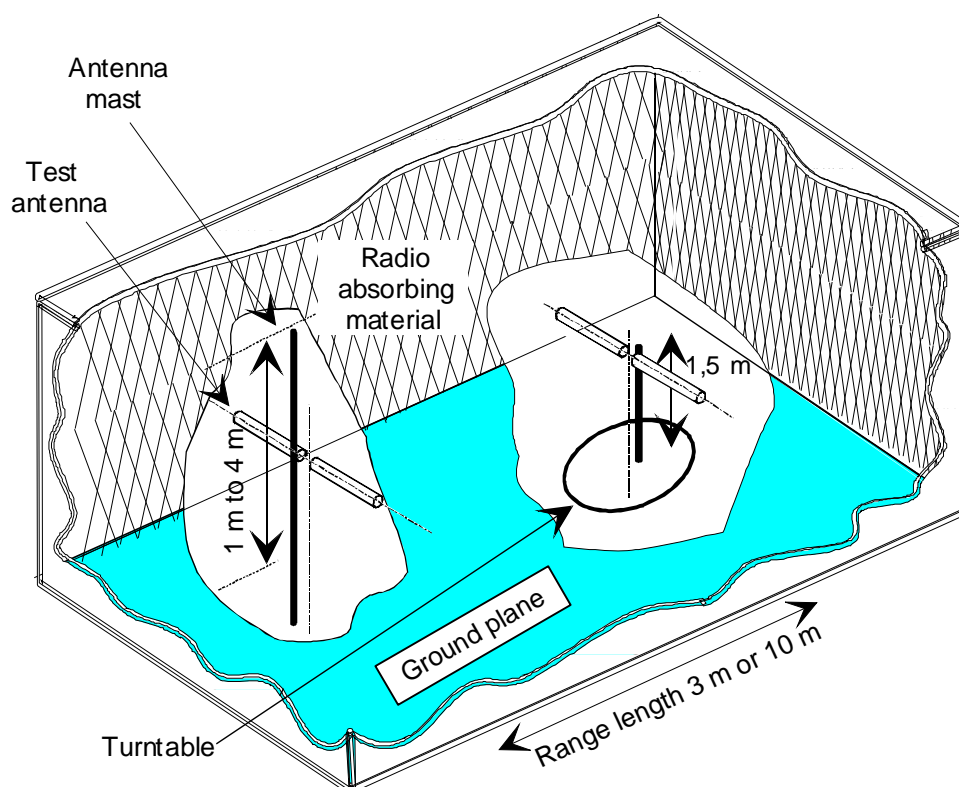

Figure A.2: A typical anechoic chamber with a ground plane

In this facility the ground plane creates the wanted reflection path, such that the signal received by the receiving antenna is the sum of the signals from both the direct and reflected transmission paths. This creates a unique received signal level for each height of the transmitting antenna (or EUT) and the receiving antenna above the ground plane.

The antenna mast provides a variable height facility (from 1 m to 4 m) so that the position of the test antenna can be optimized for maximum coupled signal between antennas or between an EUT and the test antenna.

A turntable is capable of rotation through 360° in the horizontal plane and it is used to support the test sample (EUT) at a specified height, usually 1,5 m above the ground plane. The chamber shall be large enough to allow the measuring distance of at least 3 m or $2(d_1+d_2)^2/\lambda$ (m), whichever is greater (see clause A.2.5). The distance used in actual measurements shall be recorded with the test results.

Emission testing involves firstly "peaking" the field strength from the EUT by raising and lowering the receiving antenna on the mast (to obtain the maximum constructive interference of the direct and reflected signals from the EUT) and then rotating the turntable for a "peak" in the azimuth plane. At this height of the test antenna on the mast, the amplitude of the received signal is noted. Secondly the EUT is replaced by a substitution antenna (positioned at the EUT's phase or volume centre) which is connected to a signal generator. The signal is again "peaked" and the signal generator output adjusted until the level, noted in stage one, is again measured on the receiving device.

Receiver sensitivity tests over a ground plane also involve "peaking" the field strength by raising and lowering the test antenna on the mast to obtain the maximum constructive interference of the direct and reflected signals, this time using a measuring antenna which has been positioned where the phase or volume centre of the EUT will be during testing. A transform factor is derived. The test antenna remains at the same height for stage two, during which the measuring antenna is replaced by the EUT. The amplitude of the transmitted signal is reduced to determine the field strength level at which a specified response is obtained from the EUT.

A.1.3 OATS

An OATS comprises a turntable at one end and an antenna mast of variable height at the other end above a ground plane which, in the ideal case, is perfectly conducting and of infinite extent. In practice, whilst good conductivity can be achieved, the ground plane size has to be limited. A typical OATS is shown in figure A.3.

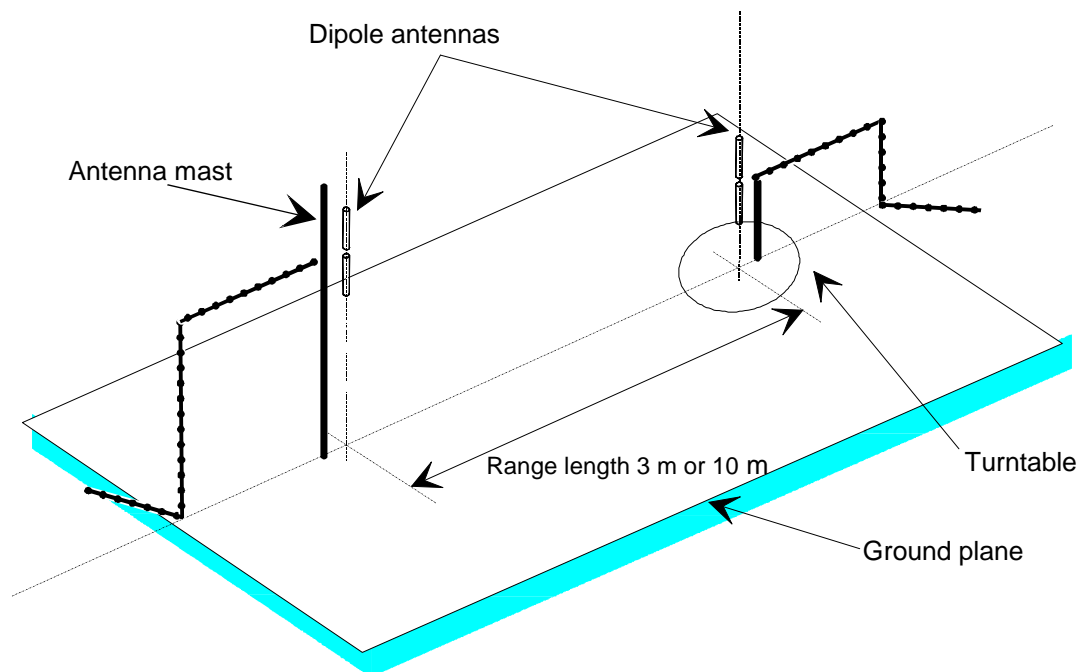

Figure A.3: A typical OATS

The ground plane creates a wanted reflection path, such that the signal received by the receiving antenna is the sum of the signals received from the direct and reflected transmission paths. The phasing of these two signals creates a unique received level for each height of the transmitting antenna (or EUT) and the receiving antenna above the ground plane.

Site qualification concerning antenna positions, turntable, measurement distance and other arrangements are same as for anechoic chamber with a ground plane. In radiated measurements an OATS is also used by the same way as anechoic chamber with a ground plane.

Typical measuring arrangement common for ground plane test sites is presented in figure A.4.

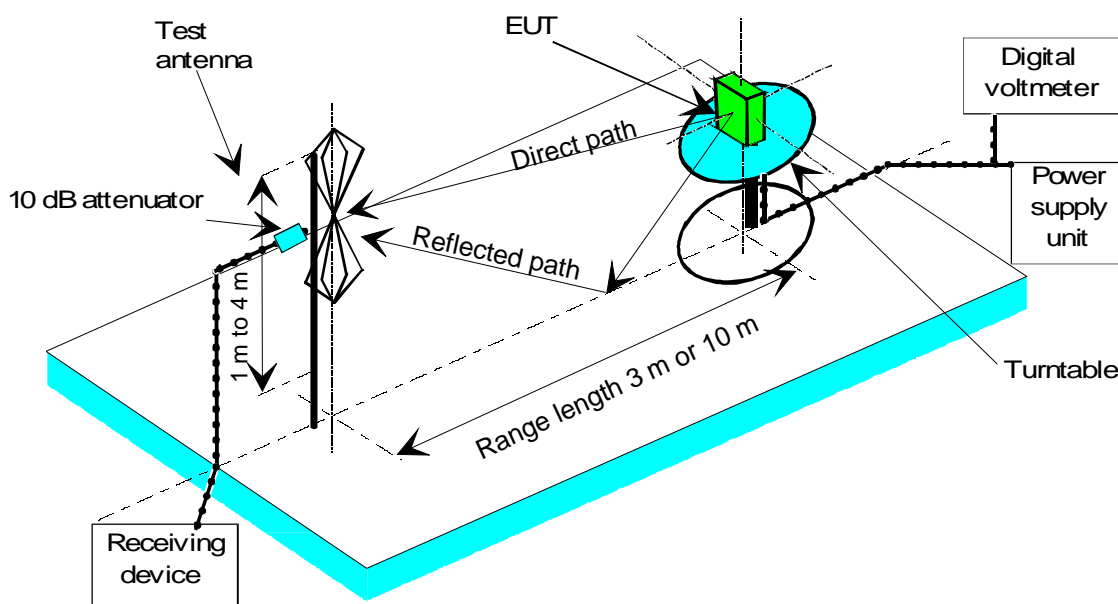

Figure A.4: Measuring arrangement on ground plane test site (OATS set-up for spurious emission testing)

A.1.4 Test antenna

A test antenna is always used in radiated test methods. In emission tests (i.e. frequency error, effective radiated power, spurious emissions and adjacent channel power) the test antenna is used to detect the field from the EUT in one stage of the measurement and from the substitution antenna in the other stage. When the test site is used for the measurement of receiver characteristics (i.e. sensitivity and various immunity parameters) the antenna is used as the transmitting device.

The test antenna should be mounted on a support capable of allowing the antenna to be used in either horizontal or vertical polarization which, on ground plane sites (i.e. anechoic chambers with ground planes and OATS), should additionally allow the height of its centre above the ground to be varied over the specified range (usually 1 m to 4 m).

In the frequency band 30 MHz to 1 000 MHz, dipole antennas (constructed in accordance with ANSI C63.5 [1]) are generally recommended. For frequencies of 80 MHz and above, the dipoles should have their arm lengths set for resonance at the frequency of test. Below 80 MHz, shortened arm lengths are recommended. For spurious emission testing, however, a combination of bicones and log periodic dipole array antennas (commonly termed "log periodics") could be used to cover the entire 30 MHz to 1 000 MHz band. Above 1 000 MHz, waveguide horns are recommended although, again, log periodics could be used.

NOTE: The gain of a horn antenna is generally expressed relative to an isotropic radiator.

A.1.5 Substitution antenna

The substitution antenna is used to replace the EUT for tests in which a transmitting parameter (i.e. frequency error, effective radiated power, spurious emissions and adjacent channel power) is being measured. For measurements in the frequency band 30 MHz to 1 000 MHz, the substitution antenna should be a dipole antenna (constructed in accordance with ANSI C63.5 [1]). For frequencies of 80 MHz and above, the dipoles should have their arm lengths set for resonance at the frequency of test. Below 80 MHz, shortened arm lengths are recommended. For measurements above 1 000 MHz, a waveguide horn is recommended. The centre of this antenna should coincide with either the phase centre or volume centre (as specified in the test method) of the EUT it has replaced.

A.1.6 Measuring antenna

The measuring antenna is used in tests on an EUT in which a receiving parameter (i.e. sensitivity and various immunity tests) is being measured. Its purpose is to enable a measurement of the electric field strength in the vicinity of the EUT. For measurements in the frequency band 30 MHz to 1 000 MHz, the measuring antenna should be a dipole antenna (constructed in accordance with ANSI C63.5 [1]). For frequencies of 80 MHz and above, the dipoles should have their arm lengths set for resonance at the frequency of test. Below 80 MHz, shortened arm lengths are recommended. The centre of this antenna should coincide with either the phase centre or volume centre (as specified in the test method) of the EUT.

A.2 Guidance on the use of radiation test sites

This clause details procedures, test equipment arrangements and verification that should be carried out before any of the radiated test are undertaken. These schemes are common to all types of test sites described in this annex.

A.2.1 Verification of the test site

No test should be carried out on a test site which does not possess a valid certificate of verification. The verification procedures for the different types of test sites described in this annex (i.e. anechoic chamber, anechoic chamber with a ground plane and OATS) are given in TR 102 273 [i.2], parts 2, 3 and 4, respectively.

A.2.2 Preparation of the EUT

The manufacturer should supply information about the EUT covering the operating frequency, polarization, supply voltage(s) and the reference face. Additional information, specific to the type of EUT should include, where relevant, carrier power, CSP, whether different operating modes are available (e.g. high and low power modes) and if operation is continuous or is subject to a maximum test duty cycle (e.g. 1 m on, 4 m off).

Where necessary, a mounting bracket of minimal size should be available for mounting the EUT on the turntable. This bracket should be made from low conductivity, low relative dielectric constant (i.e. less than 1,5) material(s) such as expanded polystyrene, balsa wood, etc.

A.2.3 Power supplies to the EUT

All tests should be performed using power supplies wherever possible, including tests on EUT designed for battery-only use. In all cases, power leads should be connected to the EUT's supply terminals (and monitored with a digital voltmeter) but the battery should remain present, electrically isolated from the rest of the equipment, possibly by putting tape over its contacts.

The presence of these power cables can, however, affect the measured performance of the EUT. For this reason, they should be made to be "transparent" as far as the testing is concerned. This can be achieved by routing them away from the EUT and down to the either the screen, ground plane or facility wall (as appropriate) by the shortest possible paths. Precautions should be taken to minimize pick-up on these leads (e.g. the leads could be twisted together, loaded with ferrite beads at 0,15 m spacing or otherwise loaded).

Details shall be included in the test report.

A.2.4 Volume control setting for analogue speech tests

Unless otherwise stated, in all receiver measurements for analogue speech the receiver volume control where possible, should be adjusted to give at least 50 % of the rated audio output power. In the case of stepped volume controls, to volume control should be set to the first step that provides an output power of at least 50 % of the rated audio output power. This control should not be readjusted between normal and extreme test conditions in tests.

A.2.5 Range length

The range length for all these types of test facility should be adequate to allow for testing in the far-field of the EUT i.e. it should be equal to or exceed:

$$\frac{2(d_1+d_2)^2}{\lambda}$$

where:

- d_1 is the largest dimension of the EUT/dipole after substitution (m);
- d_2 is the largest dimension of the test antenna (m);
- λ is the test frequency wavelength (m).

It should be noted that in the substitution part of this measurement, where both test and substitution antennas are half wavelength dipoles, this minimum range length for far-field testing would be:

$$2\lambda$$

It should be noted in the test report when either of these conditions is not met so that the additional measurement uncertainty can be incorporated into the results.

NOTE 1: **For the fully anechoic chamber**, no part of the volume of the EUT should, at any angle of rotation of the turntable, fall outside the "quiet zone" of the chamber at the nominal frequency of the test.

NOTE 2: The "quiet zone" is a volume within the anechoic chamber (without a ground plane) in which a specified performance has either been proven by test, or is guaranteed by the designer/manufacture. The specified performance is usually the reflectivity of the absorbing panels or a directly related parameter (e.g. signal uniformity in amplitude and phase). It should be noted however that the defining levels of the quiet zone tend to vary.

NOTE 3: **For the anechoic chamber with a ground plane**, a full height scanning capability, i.e. 1 m to 4 m, should be available for which no part of the test antenna should come within 1 m of the absorbing panels. For both types of **anechoic chamber**, the reflectivity of the absorbing panels should not be worse than -5 dB.

NOTE 4: **For both the anechoic chamber with a ground plane and the OATS**, no part of any antenna should come within 0,25 m of the ground plane at any time throughout the tests. Where any of these conditions cannot be met, measurements should not be carried out.

A.2.6 Site preparation

The cables for both ends of the test site should be routed horizontally away from the testing area for a minimum of 2 m (unless, in the case both types of **anechoic chamber**, a back wall is reached) and then allowed to drop vertically and out through either the ground plane or screen (as appropriate) to the test equipment. Precautions should be taken to minimize pick up on these leads (e.g. dressing with ferrite beads, or other loading). The cables, their routing and dressing should be identical to the verification set-up.

NOTE: For ground reflection test sites (**i.e. anechoic chambers with ground planes and OATS**) which incorporate a cable drum with the antenna mast, the 2 m requirement may be impossible to comply with.

Calibration data for all items of test equipment should be available and valid. For test, substitution and measuring antennas, the data should include gain relative to an isotropic radiator (or antenna factor) for the frequency of test. Also, the VSWR of the substitution and measuring antennas should be known.

The calibration data on all cables and attenuators should include insertion loss and VSWR throughout the entire frequency range of the tests. All VSWR and insertion loss figures should be recorded in the log book results sheet for the specific test.

Where correction factors/tables are required, these should be immediately available.

For all items of test equipment, the maximum errors they exhibit should be known along with the distribution of the error e.g.:

- cable loss: $\pm 0,5$ dB with a rectangular distribution;
- measuring receiver: 1,0 dB (standard deviation) signal level accuracy with a Gaussian error distribution.

At the start of measurements, system checks should be made on the items of test equipment used on the test site.

A.3 Coupling of signals

A.3.1 General

The presence of leads in the radiated field may cause a disturbance of that field and lead to additional measurement uncertainty. These disturbances can be minimized by using suitable coupling methods, offering signal isolation and minimum field disturbance (e.g. optical and acoustic coupling).

A.3.2 Data signals

Isolation can be provided by the use of optical, ultra sonic or infra red means. Field disturbance can be minimized by using a suitable fibre optic connection. Ultra sonic or infra red radiated connections require suitable measures for the minimization of ambient noise.

A.3.3 Speech and analogue signals

Where an audio output connector is not available an acoustic coupler should be used.

When using the acoustic coupler, care should be exercised that possible ambient noise does not influence the test result.

A.3.3.1 Acoustic coupler description

The acoustic coupler comprises a plastic funnel, an acoustic pipe and a microphone with a suitable amplifier. The materials used to fabricate the funnel and pipe should be of low conductivity and of low relative dielectric constant (i.e. less than 1,5):

- the acoustic pipe should be long enough to reach from the EUT to the microphone which should be located in a position that will not disturb the RF field. The acoustic pipe should have an inner diameter of about 6 mm and a wall thickness of about 1,5 mm and should be sufficiently flexible so as not to hinder the rotation of the turntable;
- the plastic funnel should have a diameter appropriate to the size of the loudspeaker in the EUT, with soft foam rubber glued to its edge, it should be fitted to one end of the acoustic pipe and the microphone should be fitted to the other end. It is very important to fix the centre of the funnel in a reproducible position relative to the EUT, since the position of the centre has a strong influence on the frequency response that will be measured. This can be achieved by placing the EUT in a close fitting acoustic mounting jig, supplied by the manufacturer, of which the funnel is an integral part;
- the microphone should have a response characteristic flat within 1 dB over a frequency range of 50 Hz to 20 kHz, a linear dynamic range of at least 50 dB. The sensitivity of the microphone and the receiver audio output level should be suitable to measure a signal to noise ratio of at least 40 dB at the nominal audio output level of the EUT. Its size should be sufficiently small to couple to the acoustic pipe;
- the frequency correcting network should correct the frequency response of the acoustic coupler so that the acoustic SINAD measurement is valid (see IEC 60489-3 appendix F [3]).

A.3.3.2 Calibration

The aim of the calibration of the acoustic coupler is to determine the acoustic SINAD ratio which is equivalent to the SINAD ratio at the receiver output.

Annex B (normative): Spectrum analyser specification

Methods of measurement in clause 7.3 refer to the use of a spectrum analyser. The characteristics of the spectrum analyser shall meet at least the following requirements:

- the reading accuracy of the frequency marker shall be within ± 100 Hz;
- the accuracy of relative amplitude measurements shall be within $\pm 3,5$ dB.

It shall be possible to adjust the spectrum analyser to allow the separation on its screen of two equal amplitude components with a frequency difference of 100 Hz.

For statistically distributed modulations, the spectrum analyser and the integrating device (when appropriate) needs to allow determination of the power spectral density (energy per time and bandwidth), which has to be integrated over the bandwidth in question.

The spectrum analyser should have a dynamic range greater than 90 dB and the average phase noise in the adjacent and alternate channels shall be such that measurement of adjacent and alternate channel power (see clause 7.3) is not limited by phase noise. In order to confirm this the selected measurement technique for clause 7.3.2 shall be used to measure the adjacent and alternate channel power with a CW signal source with phase noise of less than -120 dBc/Hz at one CSP offset and -130 dBc/Hz at two CSP offset. The maximum adjacent channel power observed with these conditions shall not exceed -70 dBc, and the maximum alternate channel power measured with these conditions shall not exceed -80 dBc.

Annex C (normative): Specification for measurement filter

Methods of measurement in clause 7.6 refer to the use of a filter. The IF filter shall be within the limits of the selectivity characteristic of figure C.1.

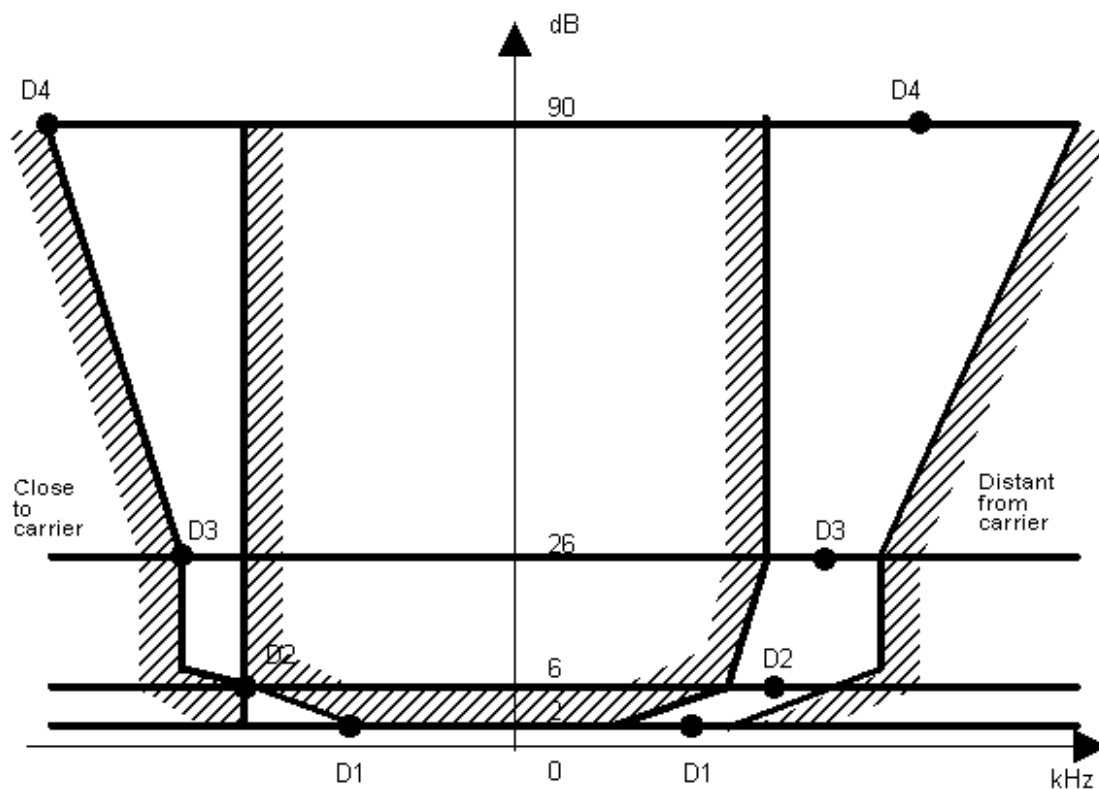

Figure C.1: IF filter

The selectivity characteristic shall keep the frequency separations from the nominal centre frequency of the adjacent channel as stated in table C.1.

Table C.1: Selectivity characteristic

Frequency separation of filter curve from nominal centre frequency of adjacent channel (kHz)			
D1	D2	D3	D4
3	4,25	5,5	9,5

The attenuation points shall not exceed the tolerances as stated in tables C.2 and C.3.

Table C.2: Attenuation points close to carrier

Tolerances range (kHz)			
D1	D2	D3	D4
+1,35	±0,1	-1,35	-5,35

Table C.3: Attenuation points distant from the carrier

Tolerance range (kHz)			
D1	D2	D3	D4
$\pm 2,0$	$\pm 2,0$	$\pm 2,0$	+2,0 -6,0

The minimum attenuation of the filter, outside the 90 dB attenuation points, shall greater than or equal to 90 dB.

Annex D (informative): Bibliography

ETSI EN 301 489-1: "Electromagnetic compatibility and Radio spectrum Matters (ERM); ElectroMagnetic Compatibility (EMC) standard for radio equipment and services; Part 1: Common technical requirements".

ETSI EN 301 489-5: "Electromagnetic compatibility and Radio spectrum Matters (ERM); ElectroMagnetic Compatibility (EMC) standard for radio equipment and services; Part 5: Specific conditions for Private land Mobile Radio (PMR) and ancillary equipment (speech and non-speech)".

Directive 1999/5/EC of the European Parliament and of the Council of 9 March 1999 on radio equipment and telecommunications terminal equipment and the mutual recognition of their conformity (R&TTE Directive).

Council Directive 89/336/EEC of 3 May 1989 on the approximation of the laws of the Member States relating to electromagnetic compatibility (EMC Directive).

History

Document history		
V1.1.1	February 1999	Publication as EN 301 166
V1.1.2	December 2001	Publication
V1.2.1	July 2007	Publication
V1.3.1	April 2008	One-step Approval Procedure OAP 20080815: 2008-04-16 to 2008-08-15
V1.3.1	August 2008	Publication