

# ETSI EN 301 166-1 V1.1.2 (2001-12)

---

*European Standard (Telecommunications series)*

**Electromagnetic compatibility  
and Radio spectrum Matters (ERM);  
Land Mobile Service;  
Radio equipment for analogue and/or digital  
communication (speech and/or data) and operating on  
narrow band channels and having an antenna connector;  
Part 1: Technical characteristics and  
methods of measurement**

---



---

**Reference**REN/ERM-TG32-045-1

---

---

**Keywords**analogue, antenna, connector, data, digital,  
mobile, PMR, radio, speech**ETSI**650 Route des Lucioles  
F-06921 Sophia Antipolis Cedex - FRANCE

---

Tel.: +33 4 92 94 42 00 Fax: +33 4 93 65 47 16

Siret N° 348 623 562 00017 - NAF 742 C  
Association à but non lucratif enregistrée à la  
Sous-Préfecture de Grasse (06) N° 7803/88

---

**Important notice**

---

Individual copies of the present document can be downloaded from:

<http://www.etsi.org>

The present document may be made available in more than one electronic version or in print. In any case of existing or perceived difference in contents between such versions, the reference version is the Portable Document Format (PDF). In case of dispute, the reference shall be the printing on ETSI printers of the PDF version kept on a specific network drive within ETSI Secretariat.

Users of the present document should be aware that the document may be subject to revision or change of status. Information on the current status of this and other ETSI documents is available at

<http://portal.etsi.org/tb/status/status.asp>

If you find errors in the present document, send your comment to:

[editor@etsi.fr](mailto:editor@etsi.fr)

---

**Copyright Notification**

---

No part may be reproduced except as authorized by written permission.  
The copyright and the foregoing restriction extend to reproduction in all media.

© European Telecommunications Standards Institute 2001.  
All rights reserved.

# Contents

Intellectual Property Rights .....	8
Foreword.....	8
Introduction .....	9
1 Scope .....	10
2 References .....	10
3 Definitions, symbols and abbreviations .....	11
3.1 Definitions .....	11
3.2 Symbols.....	13
3.3 Abbreviations .....	13
4 General .....	13
4.1 Presentation of equipment for testing purposes.....	13
4.1.1 Choice of model for type testing.....	14
4.1.2 Definitions of Switching Range (SR), alignment range and operating frequency range .....	14
4.1.2.1 Definition of SR.....	14
4.1.2.2 Definition of alignment range .....	14
4.1.2.3 Definition of Operating Frequency Range (OFR).....	14
4.1.3 Definition of the categories of the alignment range (AR0, AR1, AR2 and AR3) .....	14
4.1.4 Testing of equipment of category AR0.....	15
4.1.5 Testing of equipment of category AR1.....	15
4.1.6 Testing of equipment of category AR2.....	15
4.1.7 Testing of equipment of category AR3.....	15
4.1.8 Testing of equipment capable of being aligned to operate with more than one Channel Separation (CSP) .....	15
4.1.9 Number of samples for type testing .....	15
4.1.10 Testing of a family of equipment with a total operating range in excess of each equipment's alignments range.....	16
4.1.11 Testing of equipment with alternative power levels .....	16
4.1.12 Testing of equipment with alternative hardware configurations.....	16
4.1.13 Testing of equipment that does not have an external 50 $\Omega$ RF connector (integral antenna equipment) .....	16
4.1.13.1 Equipment with an internal permanent or temporary antenna connector.....	16
4.1.13.2 Equipment with a temporary antenna connector.....	17
4.2 Testing using bit streams or messages.....	17
4.3 Interpretation of the measurement results .....	17
4.4 Transmitter power .....	17
4.5 Facilities sockets .....	17
5 Test conditions, power sources and ambient temperatures .....	18
5.1 Normal and extreme test conditions .....	18
5.2 Test power source.....	18
5.3 Normal test conditions.....	18
5.3.1 Normal temperature and humidity .....	18
5.3.2 Normal test power source .....	18
5.3.2.1 Mains voltage.....	18
5.3.2.2 Regulated lead-acid battery power sources used on vehicles.....	18
5.3.2.3 Other power sources.....	19
5.4 Extreme test conditions .....	19
5.4.1 Extreme temperatures .....	19
5.4.2 Extreme test source voltages.....	19
5.4.2.1 Mains voltage.....	19
5.4.2.2 Regulated lead-acid battery power sources used on vehicles.....	19
5.4.2.3 Power sources using other types of batteries.....	19
5.4.2.4 Other power sources.....	19
5.5 Procedure for tests at extreme temperatures.....	20

5.5.1	Procedure for equipment designed for continuous transmission.....	20
5.5.2	Procedure for equipment designed for intermittent transmission .....	20
6	General conditions.....	20
6.1	Test signals.....	20
6.1.1	Transmitter test signals (B1), (M5) and (M7).....	20
6.1.2	Receiver test signal for analogue equipment .....	21
6.1.3	Receiver test signals for data (and digitized voice) equipment (M2), (M3), (M4) and (M6) .....	21
6.1.4	Transmitter effective radiated power test signal (C1).....	21
6.2	Test load (artificial antenna).....	21
6.3	PEP.....	22
6.4	Encoders.....	22
6.5	Modulation processing .....	22
6.6	Test sites and general arrangements for radiated measurements .....	22
6.7	Transmitter automatic shut-off facility.....	22
6.8	Arrangement for analogue test signals at the input of the transmitter .....	22
6.9	Arrangement for test signals at the input of the receiver .....	22
6.10	Receiver mute or squelch facility .....	23
6.11	Receiver rated audio output power.....	23
6.12	Facilities for access .....	23
6.12.1	Analogue access.....	23
6.12.2	Test points for bit stream measurements.....	23
6.12.3	Coupling arrangements .....	23
6.12.3.1	Arrangements for measurements with continuous bit streams .....	23
6.12.3.2	Arrangements for measurements with messages.....	24
6.12.4	Modes of operation of the transmitter.....	24
6.13	Tests of equipment with a duplex filter .....	24
7	Technical characteristics of the transmitter.....	24
7.1	Maximum power (PX) (conducted).....	24
7.1.1	Definition.....	24
7.1.2	Method of measurement .....	24
7.1.3	Limit .....	25
7.2	Maximum effective radiated power.....	25
7.2.1	Definition.....	25
7.2.2	Method of measurement .....	25
7.2.2.1	Evaluation of CW-to-PEP correction factor for signal C1 .....	25
7.2.2.2	Measurements on a test site.....	25
7.2.3	Limit .....	26
7.3	Adjacent and alternate channels power .....	27
7.3.1	Definition.....	27
7.3.2	Methods of measurement.....	27
7.3.3	Limit .....	28
7.4	Spurious emissions .....	29
7.4.1	Definition.....	29
7.4.2	Method of measurement .....	29
7.4.2.1	Method of measuring conducted spurious emissions in a specified load (clause 7.4.1 (a)) .....	29
7.4.2.2	Method of measuring the effective radiated power (clause 7.4.1 (b)).....	29
7.4.2.3	Method of measuring the effective radiated power (clause 7.4.1 (c)).....	30
7.4.3	Limits.....	31
7.5	Intermodulation attenuation.....	31
7.5.1	Definition.....	31
7.5.2	Method of measurement .....	32
7.5.3	Limits.....	33
7.6	Transient power.....	33
7.6.1	Definition.....	33
7.6.2	Method of measurement .....	33
7.6.2.1	Characteristics of the transient power measuring device .....	34
7.6.3	Limits.....	34
7.7	Frequency error .....	34
7.7.1	Definition.....	34
7.7.2	Method of measurement .....	35

7.7.3	Limits.....	35
8	Technical characteristics of the receiver .....	36
8.1	Maximum usable sensitivity (analogue, conducted) .....	36
8.1.1	Definition.....	36
8.1.2	Method of measuring the SINAD ratio.....	36
8.1.3	Limits.....	36
8.2	Maximum usable sensitivity (analogue, field strength).....	36
8.2.1	Definition.....	37
8.2.2	Method of measurement .....	37
8.2.3	Limits.....	38
8.3	Maximum usable sensitivity (data, conducted) .....	38
8.3.1	Definition.....	38
8.3.2	Methods of measurement.....	38
8.3.2.1	Method of measurement with continuous bit streams.....	38
8.3.2.2	Method of measurement with messages.....	39
8.3.3	Limits.....	39
8.4	Maximum usable sensitivity (data, field strength) .....	39
8.4.1	Definition.....	40
8.4.2	Method of measurement .....	40
8.4.2.1	Method of measurement with continuous bit streams.....	40
8.4.2.2	Method of measurement with messages.....	41
8.4.3	Limits.....	42
8.5	Adjacent channel selectivity.....	43
8.5.1	Definition.....	43
8.5.2	Method of measurement .....	43
8.5.2.1	Method of measurement (analogue).....	43
8.5.2.2	Method of measurement (data with continuous bit stream) .....	44
8.5.2.3	Method of measurement with messages.....	44
8.5.3	Limits.....	45
8.6	Spurious response rejection.....	45
8.6.1	Definition.....	46
8.6.2	Method of measurement .....	46
8.6.2.1	Introduction to the method of measurement.....	46
8.6.2.2	Method of search over the "limited frequency range".....	46
8.6.2.3	Method of measurement (analogue).....	47
8.6.2.4	Method of measurement (data with continuous bit streams).....	48
8.6.2.5	Method of measurement (data with messages) .....	48
8.6.3	Limits.....	49
8.7	Intermodulation response rejection .....	49
8.7.1	Definition.....	49
8.7.2	Method of measurement .....	50
8.7.2.1	Method of measurement (analogue).....	50
8.7.2.2	Method of measurement (data with continuous bit stream) .....	51
8.7.2.3	Method of measurement with messages.....	51
8.7.3	Limit .....	52
8.8	Blocking or desensitization .....	53
8.8.1	Definition.....	53
8.8.2	Method of measurement .....	53
8.8.2.1	Method of measurement (analogue).....	53
8.8.2.2	Method of measurement (data with continuous bit stream) .....	54
8.8.2.3	Method of measurement with messages.....	54
8.8.3	Limit .....	55
8.9	Spurious radiations .....	55
8.9.1	Definition.....	55
8.9.2	Methods of measurement.....	56
8.9.2.1	Method of measuring the power level in a specified load (clause 8.9.1a)) .....	56
8.9.2.2	Method of measuring the effective radiated power (clause 8.9.1b)) .....	56
8.9.2.3	Method of measuring the effective radiated power (clause 8.9.1.c)).....	57
8.9.3	Limits.....	57
8.10	Co-channel rejection.....	57
8.10.1	Definition.....	57

8.10.2	Methods of measurement .....	58
8.10.2.1	Method of measurement (analogue).....	58
8.10.2.2	Method of measurement (data with continuous bit stream) .....	58
8.10.2.3	Method of measurement with messages.....	59
8.10.3	Limits.....	60
9	Duplex operation .....	60
9.1	Receiver desensitization (with simultaneous transmission and reception).....	60
9.1.1	Definition.....	60
9.1.2	Methods of measurement.....	61
9.1.2.1	Desensitization measured with analogue modulation .....	61
9.1.2.1.1	Method of measurement when the equipment has a duplex filter .....	61
9.1.2.1.2	Method of measurement when the equipment has to operate with two antennas .....	62
9.1.2.2	Desensitization measured with continuous bit streams .....	63
9.1.2.2.1	Method of measurement when the equipment has a duplex filter .....	63
9.1.2.2.2	Method of measurement when the equipment has to operate with two antennas .....	64
9.1.2.3	Desensitization measured with messages.....	65
9.1.2.3.1	Method of measurement when the equipment has a duplex filter .....	65
9.1.2.3.2	Method of measurement when the equipment has to operate with two antennas .....	66
9.1.3	Limits.....	67
9.2	Receiver spurious response rejection (with simultaneous transmission and reception) .....	67
9.2.1	Definition.....	67
9.2.2	Method of measurement .....	67
9.2.3	Limits.....	70
10	Measurement uncertainty .....	71
<b>Annex A (normative): Radiated measurement.....</b>		<b>72</b>
A.1	Test sites and general arrangements for measurements involving the use of radiated fields.....	72
A.1.1	Anechoic chamber.....	72
A.1.2	Anechoic chamber with a ground plane .....	73
A.1.3	OATS .....	74
A.1.4	Test antenna.....	75
A.1.5	Substitution antenna .....	75
A.1.6	Measuring antenna .....	76
A.2	Guidance on the use of radiation test sites .....	76
A.2.1	Verification of the test site .....	76
A.2.2	Preparation of the EUT.....	76
A.2.3	Power supplies to the EUT.....	76
A.2.4	Volume control setting for analogue speech tests .....	76
A.2.5	Range length.....	77
A.2.6	Site preparation .....	77
A.3	Coupling of signals.....	78
A.3.1	General .....	78
A.3.2	Data signals .....	78
A.3.3	Speech and analogue signals .....	78
A.3.3.1	Acoustic coupler description.....	78
A.3.3.2	Calibration .....	79
<b>Annex B (normative): Spectrum analyser specification .....</b>		<b>80</b>
<b>Annex C (normative): Graphical representation of the selection of equipment and frequencies for testing .....</b>		<b>81</b>
C.1	Tests on a single sample.....	81
C.2	Tests and samples needed when the SR is a subset of the alignment range.....	82
C.3	Tests and samples for a family of equipment where the alignment range is a subset of the total OFR .....	83
C.3.1	Test scenario 1.....	83
C.3.2	Test scenario 2.....	84

<b>Annex D (normative):</b>	<b>Specification for measurement filter .....</b>	<b>85</b>
<b>Annex E (normative):</b>	<b>Identification .....</b>	<b>87</b>
E.1	Scope .....	87
E.2	General .....	87
E.3	Position of the identification code .....	88
E.3.1	Base stations .....	88
E.3.1.1	System without windows .....	88
E.3.1.2	Systems with windows .....	88
E.3.2	Handportable and mobile stations .....	88
E.4	Bit rates and modulations .....	89
E.5	Format of the identification .....	89
E.6	Synchronization .....	90
E.7	Code and block length .....	90
E.8	Contents of the identification block .....	91
E.8.1	Header .....	91
E.8.2	Country code .....	92
E.8.3	National Information .....	93
E.8.3.1	Field description .....	93
E.8.3.2	Field size options .....	93
E.8.3.3	Options for the organization of the fields .....	94
E.8.3.4	Examples of user/system information usage .....	94
E.9	Combinations .....	95
E.9.1	List of possible combinations .....	95
E.9.2	Relations between country code and allowed combinations .....	95
E.9.3	Interpretation of the fields of the ID block .....	96
History	.....	97

---

## Intellectual Property Rights

IPRs essential or potentially essential to the present document may have been declared to ETSI. The information pertaining to these essential IPRs, if any, is publicly available for **ETSI members and non-members**, and can be found in ETSI SR 000 314: "*Intellectual Property Rights (IPRs); Essential, or potentially Essential, IPRs notified to ETSI in respect of ETSI standards*", which is available from the ETSI Secretariat. Latest updates are available on the ETSI Web server (<http://webapp.etsi.org/IPR/home.asp>).

Pursuant to the ETSI IPR Policy, no investigation, including IPR searches, has been carried out by ETSI. No guarantee can be given as to the existence of other IPRs not referenced in SR 000 314 (or the updates on the ETSI Web server) which are, or may be, or may become, essential to the present document.

---

## Foreword

This European Standard (Telecommunications series) has been produced by ETSI Technical Committee Electromagnetic compatibility and Radio spectrum Matters (ERM).

The present document is part 1 of a multi-part deliverable covering Land Mobile Service; Radio equipment for analogue and/or digital communication (speech and/or data) and operating on narrow band channels and having an antenna connector, as identified below:

**Part 1: "Technical characteristics and methods of measurement";**

Part 2: "Harmonized EN covering essential requirements under article 3.2 of the R&TTE Directive".

<b>National transposition dates</b>	
Date of latest announcement of this EN (doa):	28 February 2002
Date of latest publication of new National Standard or endorsement of this EN (dop/e):	31 August 2002
Date of withdrawal of any conflicting National Standard (dow):	31 August 2002



---

## Introduction

The present document is intended to specify the minimum performance for co-existence of land mobile radio equipment as specified in the scope. Methods of measurement are also included.

The present document is also intended to be used by accredited test laboratories for the assessment of the performance of equipment. The performance of the equipment submitted for type testing is expected to be representative of the performance of the corresponding production model (see appropriate CEPT documents e.g. application forms for type testing). In order to avoid ambiguity in that assessment, the present document contains instructions for the presentation of equipment for type testing purposes, methods of measurement and test conditions.

The present document was drafted on the assumption that:

- type test measurements performed in an accredited testing laboratory in one country would be accepted by the administration in another country provided that the national regulatory requirements are met (in accordance with CEPT/ERC Recommendation 01-06 [2]);
- if equipment available on the market is required to be checked it should be tested in accordance with the methods specified in the present document.

Mechanisms for mutual recognition of type approval have been defined in ERC/DEC(97)10 [6].

Decision ERC/DEC(97)10 [6] also addresses issues related to "total quality management".

---

# 1 Scope

The present document covers the co-existence requirements for radio transmitters and receivers used in stations in the Private Mobile Radio (PMR) service. It applies to use in the land mobile service, operating on radio frequencies between 30 MHz and 3 GHz, with narrow channel separations (CSP) (less than 10 kHz) and intended for speech and/or data. It is the intention of the present document to cover any Channel Bandwidths (CBW) permitted by CEPT for such systems e.g. 6,25 kHz.

In the present document different requirements are given for the different radio frequency bands, environmental conditions and types of equipment where appropriate.

In the present document, data transmission systems are defined as systems which transmit and/or receive data and/or digitized voice. The equipment comprises a transmitter and associated encoder and modulator and/or a receiver and associated demodulator and decoder.

The present document covers equipment which may use constant envelope or non-constant envelope modulation.

The types of equipment covered by the present document are as follows:

- base station: equipment fitted with antenna socket;
- mobile station: equipment fitted with antenna socket.

Handportable stations:

- a) either fitted with an antenna socket; or
- b) without an external antenna socket (integral antenna equipment) but fitted with a permanent internal or a temporary internal 50  $\Omega$  RF connector which allows access to the transmitter output and the receiver input.

For the type of equipment defined in b) the following additional measurements are made using the equipment antenna connected to the station (and not using any connector):

- transmitter effective radiated power;
- transmitter radiated spurious emissions;
- receiver maximum usable sensitivity (field strength);
- receiver spurious radiations.

Handportable station equipment without an external or internal Radio Frequency (RF) connector and without the possibility of having a temporary internal 50  $\Omega$  RF connector is not covered by the present document.

---

# 2 References

The following documents contain provisions which, through reference in this text, constitute provisions of the present document.

- References are either specific (identified by date of publication and/or edition number or version number) or non-specific.
- For a specific reference, subsequent revisions do not apply.
- For a non-specific reference, the latest version applies.

[1] ETSI ETR 028 (1994): "Radio Equipment and Systems (RES); Uncertainties in the measurement of mobile radio equipment characteristics".

[2] CEPT/ERC Recommendation 01-06: "Procedure for mutual recognition of type testing and type approval for radio equipment".

- [3] ITU-T Recommendation O.153: "Basic parameters for the measurement of error performance at bit rates below the primary rate".
- [4] IEC 60489-3: "Methods of measurement for radio equipment used in the mobile services; Part 3: Receivers for A3E or F3E emissions" Second edition (1988) appendix F".
- [5] ETSI ETR 273 (1995): "Electromagnetic compatibility and Radio spectrum Matters (ERM); Improvement of radiated methods of measurement (using test sites) and evaluation of the corresponding measurement uncertainties".
- [6] CEPT/ERC/DEC(97)10: "ERC Decision of 30 June 1997 on the mutual recognition of conformity assessment procedures including marking of radio equipment and radio terminal equipment".
- [7] ANSI C63.5 (1988): "Electromagnetic Compatibility; Radiated Emission Measurements in Electromagnetic Interference (EMI) Control; Calibration of Antennas".
- [8] ETSI EN 300 279: "Electromagnetic compatibility and Radio spectrum Matters (ERM); ElectroMagnetic Compatibility (EMC) standard for Private land Mobile Radio (PMR) and ancillary equipment (speech and/or non-speech)".
- [9] ITU-R Recommendation SM.329-7 (1997): "Spurious emissions".
- [10] ITU-T Recommendation O.41 (1984): "Psophometer for use on telephone-type circuits".
- [11] Council Directive 89/336/EEC of 3 May 1989 on the approximation of the laws of the Member States relating to electromagnetic compatibility".

---

## 3 Definitions, symbols and abbreviations

### 3.1 Definitions

For the purposes of the present document the following terms and definitions apply:

**base station:** equipment fitted with an antenna socket, for use with an external antenna and intended for use in a fixed location

**mobile station:** mobile equipment fitted with an antenna socket, for use with an external antenna, normally used in a vehicle or as a transportable station

**handportable station:** equipment either fitted with an antenna socket or an integral antenna, or both, normally used on a stand-alone basis, to be carried on a person or held in the hand

**audio frequency input socket:** socket normally intended for connection to a microphone for the purpose of voice transmission

NOTE: (In some cases, this socket could be expected to be used for the input of an audio sub-carrier, modulated to carry data, such as FFSK).

**facilities socket:** any socket intended for purposes other than the transmission of voice

NOTE 1: The purpose of the socket and required input signals are specified by the manufacturer.

NOTE 2: The audio frequency input socket and the facilities socket may be the same physical socket in some implementations.

**integral antenna:** antenna designed to be connected to the equipment without the use of a 50  $\Omega$  external connector and considered to be part of the equipment

NOTE: An integral antenna may be fitted internally or externally to the equipment.

**full tests:** In all cases except where qualified as "limited", tests are performed according to the present document. The receiver tests performed will be selected from clause 8, as appropriate, depending upon whether the equipment is intended for either analogue voice or data/digitized voice reception. In the case where equipment is capable of both analogue voice and data reception, both sets of tests shall be conducted.

**limited tests:** The limited tests are as follows:

- receiver maximum usable sensitivity (conducted) (see clauses 8.1 and 8.3);
- receiver maximum usable sensitivity (field strength) (see clauses 8.2 and 8.4), integral antenna equipment only;
- receiver adjacent channel selectivity (see clause 8.5);
- transmitter peak envelope power (PEP) (conducted) (see clause 7.1);
- transmitter effective radiated power (see clause 7.2), integral antenna equipment only;
- transmitter adjacent and alternate channels power (see clause 7.3);
- frequency error (see clause 7.7).

**conducted measurements:** measurements which are made using direct 50  $\Omega$  connection to the equipment under test

**radiated measurements:** measurements which involve the absolute measurement of a radiated field

**50  $\Omega$ :** 50 ohm non-reactive impedance

**adjacent and alternate channels:**

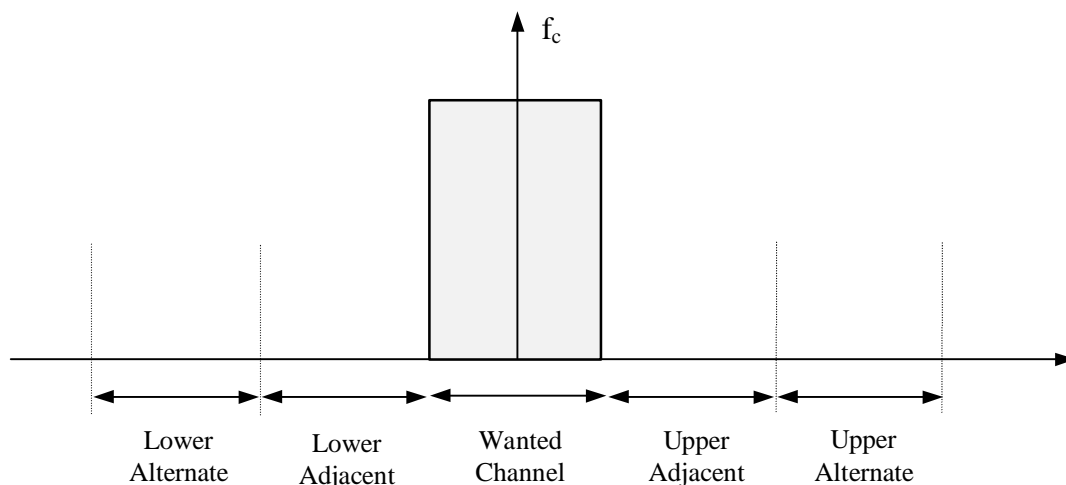

**Figure 1: Adjacent and alternate channel definitions**

**necessary bandwidth:** For a given class of emission, the width of the frequency band which is just sufficient to ensure the transmission of information at the rate and with the quality required under specified conditions, see ITU-R Recommendation SM.329-7.

**bit:** binary digit

**block:** smallest quantity of information that is sent over the radio channel

NOTE: A constant number of useful bits are always sent together with the corresponding redundancy bits.

**packet:** one block or a contiguous stream of blocks sent by one (logical) transmitter to one particular receiver or one particular group of receivers

**transmission (physical):** one or several packets transmitted between power on and power off of a particular transmitter

**window:** set of inter-related transmissions which may be limited in time by an appropriate access protocol and corresponding occupation rules

**session:** set of inter-related exchange of packets occupying one or several windows or part thereof (if applicable)

NOTE: A session corresponds to a complete interactive procedure for interchanging data between users, comprising initiation, data transmission and termination procedures. The session can be short (e.g. 2 packets), or long (e.g. one full page of text).

**message:** user data to be transferred in one or more packets in a session

## 3.2 Symbols

For the purposes of the present document, the following symbols apply:

AR	Alignment Range (see clause 4.1)
AR0, AR1,...	Categories of alignment range as defined in clause 4.1.2.2
dB	decibel
dBm	dB relative to 1 mW
dB $\mu$ V	dB relative to 1 $\mu$ V
FT	Full tests
LT	Limited tests
M1, M2,...	names of test signals defined in clause 6.1
PX	See clause 7.1.1
PR	rms power
Tx	transmitter
$\lambda$	wavelength

## 3.3 Abbreviations

For the purposes of the present document, the following abbreviations apply:

ac	alternating current
Bit	Binary digit
CBW	Channel BandWidth
CRC	Cyclic Redundancy Code
CSP	Channel Separation
CW	Continuous Wave
EMC	ElectroMagnetic Compatibility
emf	electro-motive force
$f_c$	Channel centre frequency
LSB	Least Significant Bit
MSB	Most Significant Bit
OFR	Operating Frequency Range
PEP	Peak Envelope Power
PMR	Professional Mobile Radio
rms	root mean square
RF	Radio Frequency
SR	Switching Range
SINAD	(signal + noise + distortion)/(noise + distortion)

---

# 4 General

## 4.1 Presentation of equipment for testing purposes

Each equipment submitted for type testing shall fulfil the requirements of the present document on all channels over which it is intended to operate.

The manufacturer should choose the appropriate frequencies for testing in consultation with the administration(s) from whom type approval is sought and in accordance with clauses 4.1.5 to 4.1.12 (see also annex C).

To simplify and harmonize the type testing procedures between the different testing laboratories, measurements shall be performed, according to the present document, on samples of equipment defined in clauses 4.1.1 to 4.1.13, see also annex C.

These clauses are intended to give confidence that the requirements set out in the present document have been met without the necessity of performing measurements on all channels.

#### 4.1.1 Choice of model for type testing

The manufacturer shall provide one or more samples of the equipment, as appropriate, for type testing.

If an equipment has several optional features, considered not to affect the RF parameters then tests need only be performed on the equipment configured with that combination of features considered to be the most complex, as proposed by the manufacturer and agreed by the test laboratory.

In the case of hand portable equipment without a 50  $\Omega$  external antenna connector see clause 4.1.13.

#### 4.1.2 Definitions of Switching Range (SR), alignment range and operating frequency range

##### 4.1.2.1 Definition of SR

The manufacturer shall state the SR of the receiver and the transmitter (which may differ).

The SR is the maximum frequency range, as specified by the manufacturer, over which the receiver or the transmitter can be operated within the alignment range without reprogramming or realignment.

##### 4.1.2.2 Definition of alignment range

The manufacturer shall also, when submitting equipment for type testing, state the alignment ranges for the receiver and the transmitter.

The Alignment Range (AR) is defined as the frequency range over which the receiver and/or the transmitter can be programmed and/or aligned to operate, without any change to the circuit other than the substitution of programmable read only memories or crystals (for the receiver and transmitter) and the trimming of discrete components.

Trimming is an act by which the value (in this case relating to frequency) of a component is changed within the circuit. This act may include the physical alteration, substitution (by components of similar size and type) or activation/de-activation (via the setting of soldered bridges) of components.

For the purpose of all measurements, the receiver and transmitter shall be considered separately.

##### 4.1.2.3 Definition of Operating Frequency Range (OFR)

The OFR is the total range of frequencies covered either by one type, or by a family of equipment.

It is noted that a family of equipment may be capable of covering a wider frequency range than the alignment frequency range of one type of equipment.

#### 4.1.3 Definition of the categories of the alignment range (AR0, AR1, AR2 and AR3)

The alignment range falls into one of four categories:

- the first category, defined as AR0, corresponds to equipment having an alignment range of less than or equal to 5 MHz;
- the second category, defined as AR1, corresponds to an alignment range greater than 5 MHz but less than or equal to 30 MHz;

- the third category, defined as AR2, corresponds to an alignment range greater than 30 MHz, but less than or equal to 60 MHz;
- the fourth category, defined as AR3, corresponds to an alignment range greater than 60 MHz.

#### 4.1.4 Testing of equipment of category AR0

FT shall be carried out on a channel within 50 kHz of the centre frequency of the alignment range, category AR0.

#### 4.1.5 Testing of equipment of category AR1

FT shall be carried out on a channel within 50 kHz of the highest frequency of the alignment range and FT on a channel within 50 kHz of the lowest frequency of the alignment range.

#### 4.1.6 Testing of equipment of category AR2

FT shall be carried out on a channel within 50 kHz of the highest frequency of the alignment range and FT on a channel within 50 kHz of the lowest frequency of the alignment range.

LT shall be carried out on a channel within 50 kHz of the centre frequency of the alignment range.

#### 4.1.7 Testing of equipment of category AR3

FT shall be carried out on two channels, one within 50 kHz of the highest, and one within 50 kHz of the lowest frequency of the alignment range.

LT shall be carried out on intermediate test channels, equally spaced ( $\pm 50$  kHz) over the alignment range and chosen such that the gaps between the test channels do not exceed 30 MHz.

#### 4.1.8 Testing of equipment capable of being aligned to operate with more than one Channel Separation (CSP)

If an equipment can be programmed and/or aligned to operate, without any physical change of components other than programmable read only memories or crystals, with more than one CSP, the measurements shall be made in accordance with clauses 4.1.4, 4.1.5, 4.1.6, and 4.1.7, for each CSP.

#### 4.1.9 Number of samples for type testing

If the SR of each equipment corresponds to its alignment range category (AR0, AR1, AR2, or AR3) then only one sample shall be tested (see figure C.1).

If the SR of the equipment is a subset of the equipment's alignment range, then the following samples shall be tested in order to cover the whole of that alignment range:

- for category AR0, one sample shall be provided for testing on a channel in the vicinity of the centre of the alignment range AR0, as specified in clause 4.1.4;
- for category AR1, two samples shall be provided, one sample for testing at a channel close to the upper edge and the other sample for testing close to the lower edge of the alignment range AR1, as specified in clause 4.1.5;
- for category AR2, three samples shall be provided, one sample for testing at a channel close to the upper edge, one sample for testing close to the lower edge and the other sample for testing in the vicinity of the centre of the alignment range AR2, as specified in clause 4.1.6;
- for category AR3, four or more samples shall be provided, one sample for testing at a channel close to the upper edge, one sample for testing close to the lower edge, and two or more samples for testing at a corresponding number of intermediate channels, as specified in clause 4.1.7.

See clause C.2 for details of the number of samples and tests.

#### 4.1.10 Testing of a family of equipment with a total operating range in excess of each equipment's alignments range

A family of equipment may be capable of covering a wider frequency range than the alignment range of one type of equipment by the use of frequency range determining components other than those specified in clause 4.1.2 and fulfilling appropriate requirements.

If this is the case, then for the purposes of type testing, the operational frequency range shall be presented as two or more alignment ranges, as appropriate, each of which is considered to be category AR0, AR1, AR2, or AR3, according to the definition in clause 4.1.3.

FT shall be carried out on a channel within 50 kHz of the highest frequency of the OFR and FT shall be carried out on a channel within 50 kHz of the lowest frequency of the OFR:

- for category AR1, LT shall be carried out on a channel within 50 kHz of the outer edges of the alignment range within the OFR, except for the channels coinciding with the highest and lowest frequencies of the OFR where FT shall be carried out;
- for category AR2, tests shall be in accordance with clause 4.1.6;
- for category AR3, tests shall be in accordance with clause 4.1.7.

See clause C.3 for examples.

#### 4.1.11 Testing of equipment with alternative power levels

If an equipment is designed to operate with different carrier power levels, provided that the power can be adjusted, programmed or remotely controlled without any physical changes, measurements of each transmitter parameter shall be performed at the lowest and highest power levels at which the transmitter is intended to operate.

#### 4.1.12 Testing of equipment with alternative hardware configurations

If a family of equipment has alternative output power levels provided by the use of separate power modules or add on stages, or additionally has alternative CSP, then each module or add on stage, shall be tested in combination with the equipment. The necessary samples and tests can be proposed by the manufacturer and or accredited test laboratory and shall be agreed with the Administration(s) based on the requirements of clause 4.1.

#### 4.1.13 Testing of equipment that does not have an external 50 $\Omega$ RF connector (integral antenna equipment)

##### 4.1.13.1 Equipment with an internal permanent or temporary antenna connector

The means to access and/or implement the internal permanent or temporary antenna connector shall be stated by the manufacturer with the aid of a diagram. The fact that use has been made of the internal antenna connection or of a temporary connection to facilitate measurements shall be recorded in the test report.

No connection shall be made to any internal permanent or temporary antenna connector during the performance of radiated emissions measurements, unless such action forms an essential part of the normal intended operation of the equipment, as declared by the manufacturer.



#### 4.1.13.2 Equipment with a temporary antenna connector

The manufacturer or his representative may submit one set of equipment with the normal antenna connected, to enable the radiated measurements to be made. He shall attend the test laboratory at conclusion of the radiated measurements, to disconnect the antenna and fit the temporary connector. The testing laboratory staff shall not connect or disconnect any temporary antenna connector.

NOTE: For example, this "temporary antenna connector" might be implemented using a 50  $\Omega$  connection point which would be normally used for connection to the antenna.

Alternatively the manufacturer or his representative may submit two sets of equipment to the test laboratory, one fitted with a temporary antenna connector with the antenna disconnected and the other with the antenna connected. Each equipment shall be used for the appropriate tests. The manufacturer shall declare that two sets of equipment are identical in all respects.

### 4.2 Testing using bit streams or messages

Manufacturers of equipment capable of transmitting data may elect to have the equipment tested using bit streams or messages. It should be noted that the methods of measurement using messages are usually more time consuming.

### 4.3 Interpretation of the measurement results

The interpretation of the results recorded in a test report for the measurements described in the present document shall be as follows:

- a) the measured value related to the corresponding limit will be used to decide whether an equipment meets the requirements of the present document;
- b) the measurement uncertainty value for the measurement of each parameter shall be included in the test report;
- c) the recorded value of the measurement uncertainty shall be, for each measurement, equal to or lower than the figures in clause 10 (table of measurement uncertainty).

### 4.4 Transmitter power

If the equipment is designed to operate with different transmitter powers, the rated power for each level or range of levels shall be declared by the manufacturer. The power adjustment control shall not be accessible to the user.

The requirements of the present document shall be met for all power levels at which the transmitter is intended to operate. For practical reasons, measurements shall be performed only at the lowest and highest power levels at which the transmitter is intended to operate.

### 4.5 Facilities sockets

Where a facilities socket is provided the manufacturer shall state the purpose of the socket and nature of the required input signal and/or the available output signals.

---

## 5 Test conditions, power sources and ambient temperatures

### 5.1 Normal and extreme test conditions

Type testing shall be made under normal test conditions, and also, where stated, under extreme test conditions.

The test conditions and procedures shall be as specified in clauses 5.2 to 5.5.

### 5.2 Test power source

During type testing the power source of the equipment shall be replaced by a test power source capable of producing normal and extreme test voltages as specified in clauses 5.3.2 and 5.4.2. The internal impedance of the test power source shall be low enough for its effect on the test results to be negligible. For the purpose of tests, the voltage of the power source shall be measured at the input terminals of the equipment.

For battery operated equipment the battery shall be removed and the test power source shall be applied as close to the battery terminals as practicable.

During tests of DC powered equipment the power source voltages shall be maintained within a tolerance of  $< \pm 1$  % relative to the voltage at the beginning of each test. The value of this tolerance is critical for power measurements, using a smaller tolerance will provide better measurement uncertainty values.

### 5.3 Normal test conditions

#### 5.3.1 Normal temperature and humidity

The normal temperature and humidity conditions for tests shall be any convenient combination of temperature and humidity within the following ranges:

temperature: +15 °C to +35 °C;

relative humidity: 20 % to 75 %.

When it is impracticable to carry out the tests under these conditions, a note to this effect, stating the ambient temperature and relative humidity during the tests, shall be added to the test report.

#### 5.3.2 Normal test power source

##### 5.3.2.1 Mains voltage

The normal test voltage for equipment to be connected to the mains shall be the nominal mains voltage. For the purpose of the present document, the nominal voltage shall be the declared voltage or any of the declared voltages for which the equipment was designed.

The frequency of the test power source corresponding to the ac mains shall be between 49 Hz and 51 Hz.

##### 5.3.2.2 Regulated lead-acid battery power sources used on vehicles

When the radio equipment is intended for operation from the usual types of regulated lead-acid battery power source used on vehicles the normal test voltage shall be 1,1 times the nominal voltage of the battery (for nominal voltages of 6 V and 12 V, these are 6,6 V and 13,2 V respectively).

### 5.3.2.3 Other power sources

For operation from other power sources or types of battery (primary or secondary), the normal test voltage shall be that declared by the equipment manufacturer.

## 5.4 Extreme test conditions

### 5.4.1 Extreme temperatures

For tests at extreme temperatures, measurements shall be made in accordance with the procedures specified in clause 5.5, at the upper and lower temperatures of one of the following two ranges:

- -20 °C to +55 °C;  
All mobile and handportable equipment.  
Base stations for outdoor/uncontrolled climate conditions.
- 0 °C to +40 °C;  
Base stations for indoor/controlled climate conditions.

In the case of base stations equipment, the manufacturer shall declare which conditions the equipment is intended to be installed in. Type test reports shall state the temperature range used.

### 5.4.2 Extreme test source voltages

#### 5.4.2.1 Mains voltage

The extreme test voltage for equipment to be connected to an ac mains source shall be the nominal mains voltage  $\pm 0\%$ .

#### 5.4.2.2 Regulated lead-acid battery power sources used on vehicles

When the equipment is intended for operation from the usual types of regulated lead-acid battery power sources used on vehicles the extreme test voltages shall be 1,3 and 0,9 times the nominal voltage of the battery (for a nominal voltage of 6 V, these are 7,8 V and 5,4 V respectively and for a nominal voltage of 12 V, these are 15,6 V and 10,8 V respectively).

#### 5.4.2.3 Power sources using other types of batteries

The lower extreme test voltages for equipment with power sources using batteries shall be as follows:

- for the nickel metal-hydride, leclanché or lithium type: 0,85 times the nominal battery voltage;
- for the mercury or nickel-cadmium type: 0,9 times the nominal battery voltage.

No upper extreme test voltages apply.

In the case where no upper extreme test voltage the nominal voltage is applicable, the corresponding four extreme test conditions are:

- $V_{\min}/T_{\min}, V_{\min}/T_{\max};$
- $(V_{\max} - \text{nominal})/T_{\min}, (V_{\max} = \text{nominal})/T_{\max}.$

#### 5.4.2.4 Other power sources

For equipment using other power sources, or capable of being operated from a variety of power sources, the extreme test voltages shall be those agreed between the equipment manufacturer and the testing laboratory and shall be recorded in the test report.

## 5.5 Procedure for tests at extreme temperatures

Before measurements are made the equipment shall have reached thermal balance in the test chamber. The equipment shall be switched off during the temperature stabilizing period.

In the case of equipment containing temperature stabilization circuits designed to operate continuously, the temperature stabilization circuits may be switched on for 15 minutes after thermal balance has been obtained, and the equipment shall then meet the specified requirements. For such equipment the manufacturer shall provide for the power source circuit feeding the crystal oven to be independent of the power source for the rest of the equipment.

If the thermal balance is not checked by measurements, a temperature stabilizing period of at least one hour, or a longer period as may be decided by the testing laboratory, shall be allowed. The sequence of measurements shall be chosen, and the humidity content in the test chamber shall be controlled so that excessive condensation does not occur.

### 5.5.1 Procedure for equipment designed for continuous transmission

If the manufacturer states that the equipment is designed for continuous transmission, the test procedure shall be as follows.

Before tests at the upper extreme temperature, the equipment shall be placed in the test chamber, and left until thermal balance is attained. The equipment shall then be switched on in the transmit condition for a period of half an hour, after which the equipment shall meet the specified requirements.

Before tests at the lower extreme temperature, the equipment shall be left in the test chamber until thermal balance is attained, then switched to the standby or receive condition for a period of one minute, after which the equipment shall meet the specified requirements.

### 5.5.2 Procedure for equipment designed for intermittent transmission

If the manufacturer states that the equipment is designed for intermittent transmission, the test procedure shall be as follows.

Before tests at the upper extreme temperature, the equipment shall be placed in the test chamber, and left until thermal balance is attained. The equipment shall then be switched on for one minute in the transmit condition, followed by four minutes in the receive condition, after which the equipment shall meet the specified requirements.

For tests at the lower extreme temperature, the equipment shall be left in the test chamber until thermal balance is attained, then switched to the standby or receive condition for one minute, after which the equipment shall meet the specified requirements.

---

## 6 General conditions

### 6.1 Test signals

#### 6.1.1 Transmitter test signals (B1), (M5) and (M7)

The manufacturer shall declare details of the modulation scheme used and identify how the percentage modulation can be measured or specified.

For tests on analogue equipment via the audio input socket terminals, the test signal B1 shall consist of two equal amplitude non harmonically related sinusoidal input signals selected by the accredited test laboratory to be in the range 500 Hz to 3 kHz with at least 500 Hz separation between them, each of which would independently drive the transmitter into its compression region. The frequency of the tones shall be recorded in the test report. The composite signal level shall be 20 dB higher than the level which produces 60 % modulation unless the output power at this drive level is less than the highest Tx output power in which case the signal level shall be set to produce the highest possible Tx output power.

For tests via any facilities sockets, test signal B1 shall be of the nature described by the manufacturer for the purpose of the socket (see clause 4.5), at a level which produces the largest value of output power (PEP) possible with analogue modulation. The resulting RF spectrum should be equivalent to that of B1 applied to the audio input terminals unless otherwise agreed with the accredited test laboratory.

For tests on digital equipment (including digital speech), test signal M5 shall consist of a pseudo-random bit sequence of at least 511 bits (according to ITU-T Recommendation O.153 [3]), at the appropriate data rate.

If the transmission of a continuous bit stream is not possible, test signal M7 shall be trains of correctly coded bits or messages. This signal shall be agreed between the manufacturer and the accredited test laboratory. Details of this test signal shall be included in the test report. An encoder as defined in clause 6.4 may be used.

For the purpose of testing PX in clauses 7.1.1 and 7.1.2 test signals M5 and M7 should produce the largest value of output power (PEP) possible with digital modulation. If this is not the case then a test signal that does produce the largest possible value of output power (PEP) with digital modulation should be used in the testing in clauses 7.1.1 and 7.1.2.

Equipment capable of transmission of digital information shall be tested with modulation M5. Equipment using analogue transmission shall be tested with modulation B1. Equipment capable of both analogue and digital transmission shall be tested separately in each mode with B1 and M5 modulation respectively.

### 6.1.2 Receiver test signal for analogue equipment

The test signal shall be agreed between the accredited test laboratory and the equipment manufacturer such that it represents the output from the transmitter and provides the necessary input for correct operation of the receiver. The test signal used shall be such as to produce a 1 kHz tone at the output of the receiver. Details of the test signal used shall be recorded in the test report.

### 6.1.3 Receiver test signals for data (and digitized voice) equipment (M2), (M3), (M4) and (M6)

When the equipment is designed to transmit continuous bit streams (e.g. data, facsimile, image transmission, digitized voice) the normal test signal shall be generated using a method as agreed between the accredited test laboratory and the equipment manufacturer and shall be as follows:

Signal M2, consisting of a RF carrying a pseudo-random bit sequence of at least 511 bits (according to ITU-T Recommendation O.153 [3]).

If the transmission of a continuous bit stream is not possible, test signal M6 shall be trains of correctly coded bits or messages. This signal shall be agreed between the manufacturer and the accredited test laboratory. Details of this test signal shall be included in the test report. An encoder as defined in clause 6.4 may be used.

Signal M3, consisting of a RF signal, modulated in frequency by an audio frequency signal of 1 kHz with a resulting deviation of 12 % of the CSP.

Signal M4, consisting of a RF signal, modulated in frequency by an audio frequency signal of 0,4 kHz with a resulting deviation of 12 % of the CSP. This signal is used as an unwanted signal.

### 6.1.4 Transmitter effective radiated power test signal (C1)

Test signal C1 shall be any signal that provides a constant envelope of output power at the output of the transmitter. This may be a CW tone or a modulated signal with constant envelope (e.g. GMSK). The envelope shall be flat to  $\pm 1$  dB.

If the equipment under test is capable of operating in non-constant envelope modes, or at higher powers than with test signal C1, the ratio, in dB, between the mean power obtained with test signal C1 and the maximum PEP for any modulating signal accepted by the transmitter shall be known as the CW-to-PEP correction factor for signal C1.

## 6.2 Test load (artificial antenna)

For conducted measurements of the transmitter, a power attenuator ("artificial antenna") shall be used, exhibiting a substantially non-reactive, non-radiating load of 50  $\Omega$  to the antenna connector and capable of dissipating the transmitter output power.

## 6.3 PEP

The PEP is the average power supplied to the artificial antenna by a transmitter during one RF cycle at the highest crest of the modulation envelope. For practical purposes the methods of measurements in clause 7.1.2 should be used.

## 6.4 Encoders

Whenever needed and in order to facilitate measurements an encoder for the data system shall accompany the model submitted, together with details of the normal modulation process. The encoder will be used to generate the test signal using a method as agreed between the test laboratory and the equipment manufacturer.

Where necessary details of all codes and code format(s) used shall be given.

In the case of equipment unable to operate with continuous bit streams, the encoder shall be capable of operation in a repetitive mode. For transmitter measurements the operation of the encoder shall enable continuous modulation for the duration of the measurements. For receiver measurements the operation of the encoder shall provide intervals between each message that are not less than the reset time of the receiver.

## 6.5 Modulation processing

Any modulation processing, if included in the transmitter, shall be operative unless otherwise specified. Any features which are not operational shall be recorded in the test report.

## 6.6 Test sites and general arrangements for radiated measurements

For guidance on radiation test sites see annex A. Detailed descriptions of the radiated measurement arrangements are included in this annex.

## 6.7 Transmitter automatic shut-off facility

If the equipment is fitted with an automatic transmitter shut-off facility it shall be made inoperative for the duration of the type test, unless it has to be left operative to protect the equipment.

If the shut-off facility is left operative the status of the equipment shall be indicated to the accredited test laboratory.

## 6.8 Arrangement for analogue test signals at the input of the transmitter

For the purpose of the present document, in the case of analogue equipment, the transmitter audio frequency modulation signal shall be applied to the terminals of the audio input socket with any microphone disconnected, unless otherwise stated.

## 6.9 Arrangement for test signals at the input of the receiver

RF test signal sources which are applied to the receiver shall present an impedance of 50  $\Omega$  to the receiver input. This requirement shall be met irrespective of whether one or more signals using a combining network are applied to the receiver simultaneously.

The levels of the test signals shall be expressed in terms of the emf at the receiver input connector.

The effects of any intermodulation products and noise produced in the test signal sources shall be negligible.

## 6.10 Receiver mute or squelch facility

If the receiver is equipped with a mute or squelch circuit, this shall be made inoperative for the duration of the tests.

## 6.11 Receiver rated audio output power

The rated audio output power shall be the maximum power, declared by the manufacturer, for which all the requirements of the present document are met. With receiver test signal (see clause 6.1.2), the audio output power shall be measured in a resistive load simulating the load with which the receiver normally operates. The impedance of this load shall be declared by the manufacturer.

## 6.12 Facilities for access

### 6.12.1 Analogue access

In order to simplify the measurements in clauses 8.2 and 8.6, a temporary access to a point where the amplitude of the analogue output of the RF part can be measured should be provided, e.g. an IF output or the demodulated subcarrier point. This access can be used to determine or verify the frequency where a spurious response is expected.

### 6.12.2 Test points for bit stream measurements

It is recognized that it is not always possible to measure the air interface bit stream. The manufacturer shall define the test points at which the equipment shall be tested in order to make the measurements on bit streams in clauses 7, 8 and 9.

Figure 2 is presented as an example for clarification only.

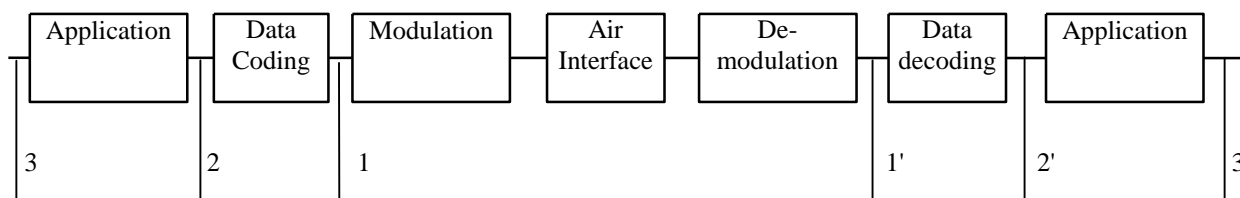

**Figure 2: Test points for bit stream measurements**

It should be noted that the closer the test access point is located to the air interface (see figure 2), a smaller number of variants may have to be type tested because the measurement is less application dependent.

The tests shall be performed by use of corresponding test points (1,1' or 2,2' or 3,3').

The test points used shall be recorded in the test report.

### 6.12.3 Coupling arrangements

If the equipment does not have an external antenna connection, arrangements shall be made by the manufacturer to couple the unit to be tested to the test equipment by a method which does not affect the radiated field (e.g. acoustic, ultrasonic or optical) and according to the clauses 6.12.3.1 and 6.12.3.2.

#### 6.12.3.1 Arrangements for measurements with continuous bit streams

For the measurements of the receiver on a test site, arrangements to couple the unit to be tested to the error observation device shall be available (see clause 6.12.2).

Furthermore, the manufacturer can also provide another facility to give access to the analogue information (see clause 6.12.1).

### 6.12.3.2 Arrangements for measurements with messages

For the measurement of the receiver on a test site, arrangements to couple the unit to be tested to the error observation device (or to an operator) shall be available.

Furthermore, the manufacturer can also provide another facility to give access to the analogue information (see clause 6.12.1).

### 6.12.4 Modes of operation of the transmitter

For the purpose of the measurements according to the present document there should preferably be a facility to operate the transmitter unmodulated. The method of obtaining an unmodulated carrier or special types of modulation patterns may be decided by agreement between the manufacturer and the test laboratory. It shall be as described in the test report. It may involve suitable temporary internal modifications of the equipment under test.

## 6.13 Tests of equipment with a duplex filter

If the equipment is provided with a built in duplex filter or a separate associated filter, the requirements of the present document shall be met when the measurements are carried out using the antenna connector of the filter.

---

## 7 Technical characteristics of the transmitter

For digital equipments that support adaptive rates, testing is only required at one bit rate. For transmitter tests in this clause this would normally be the highest bit-rate supported by the equipment. Manufacturers shall declare where any of the specific tests in this clause, if conducted at rates other than the highest bit rate, are likely to give results which are worse than at the highest bit rate. In such cases the tests will be carried out at the rate declared by the manufacturer that is likely to give the worst performance (least margin between measured results and test limits).

### 7.1 Maximum power (PX) (conducted)

This measurement applies only to equipment with an external 50  $\Omega$  antenna connector.

It is assumed that the appropriate administration will state the maximum permitted transmitter output power.

NOTE: PEP measurement is used as a figure of merit; however, it is accepted that for digital modulation the average power is often a more useful parameter.

#### 7.1.1 Definition

The PX of the transmitter is the maximum value of the output PEP for any condition of modulation.

The rated maximum power of the transmitter is that declared by the manufacturer.

#### 7.1.2 Method of measurement

For non-constant envelope modulation test signal B1, M5 or M7 (as appropriate, see clause 6.1.1) shall be applied at the transmitter. For constant envelope modulation schemes it is not required to apply modulation. The modulation used, if any, shall be recorded in the test report.

The transmitter shall be connected to a 50  $\Omega$  power attenuator, and the PEP delivered shall be measured. The measuring instrument shall have a measurement bandwidth not less than sixteen times the CBW.

The power measured is recorded as the value PX.

The measurement shall be made under normal test conditions (see clause 5.3) and repeated under extreme test conditions (see clauses 5.4.1 and 5.4.2 applied simultaneously).



### 7.1.3 Limit

The measured PX under normal test conditions shall be within  $\pm 1,5$  dB of the rated maximum power of the transmitter.

The measured PX under extreme test conditions shall be within +2 dB and -3 dB of the rated maximum power of the transmitter.

## 7.2 Maximum effective radiated power

This measurement applies only for equipment without an external 50  $\Omega$  antenna connector.

It is assumed that the appropriate administration will state the maximum permitted transmitter output power/effective radiated power.

### 7.2.1 Definition

The maximum effective radiated power of the transmitter is the maximum value of the output PEP for any condition of modulation radiated in the direction of the maximum field strength by the equipment with its integral antenna fitted. The rated maximum effective radiated power is that declared by the manufacturer.

### 7.2.2 Method of measurement

#### 7.2.2.1 Evaluation of CW-to-PEP correction factor for signal C1

The transmitter permanent internal or a temporary internal 50  $\Omega$  RF connector shall be connected to a 50  $\Omega$  power attenuator. The transmitter shall be switched on with test signal C1 (see clause 6.1.4) applied and the PEP delivered shall be measured. The measuring instrument shall have a measurement bandwidth not less than sixteen times the CBW. The mean power delivered shall also be measured. The difference between the PEP and the mean power shall be less than 1 dB.

Modulation test signal B1, M5 or M7 (as appropriate, see clause 6.1.1) shall then be applied at the transmitter. The PEP delivered to its artificial antenna shall be measured.

The difference (in dB) between the PEP measured for B1, M5 or M7 modulation and the mean power measured for C1 modulation shall be recorded. This value is the CW-to-PEP correction factor for signal C1.

#### 7.2.2.2 Measurements on a test site

On a test site, selected from annex A, the equipment, with power attenuator disconnected and the integral antenna connected, shall be placed at the specified height on a non-conducting support, in the position closest to normal use as declared by the manufacturer. This position shall be recorded in the test report.

The test antenna shall be orientated for vertical polarization and the length of the test antenna shall be chosen to correspond to the frequency of the transmitter.

The output of the test antenna shall be connected to a measuring receiver.

The transmitter shall be switched on with test signal C1 (see clause 6.1.4) applied and the measuring receiver shall be tuned to the centre frequency of the channel on which the transmitter is intended to operate.

The test antenna shall be raised and lowered through the specified range of height until a maximum signal level is detected on the measuring receiver.

When a test site according to clause A.1.1 is used there is no need to vary the height of the antenna.

The transmitter shall then be rotated through 360° in the horizontal plane until the maximum signal level is detected by the measuring receiver.

The maximum signal level detected by the measuring receiver shall be noted.

The transmitter shall be replaced by a substitution antenna as defined in clause A.1.5.

The substitution antenna shall be orientated for vertical polarization and the length of the substitution antenna shall be adjusted to correspond to the frequency of the transmitter.

The substitution antenna shall be connected to a calibrated signal generator.

The sensitivity of the measuring receiver shall be increased in accordance with the new input level (change in attenuator setting).

The test antenna shall be raised and lowered through the specified range of height to ensure that the maximum signal is received. When a test site according to clause A.1.1 is used there is no need to vary the height of the antenna.

The input signal to the substitution antenna shall be adjusted to a level that produces the level detected by the measuring receiver, that is equal to the level noted while using the transmitter under test, corrected for the change in the attenuator setting in the measuring receiver.

The input level to the substitution antenna shall be recorded as a power level.

The measurement shall be repeated with the test antenna and the substitution antenna orientated for horizontal polarization.

The measure of the maximum effective radiated power is the larger of the two power levels recorded at the input to the substitution antenna, corrected for the gain of the antenna if necessary.

The maximum effective radiated PEP is the effective radiated power corrected by the CW-to-PEP correction factor for signal C1, as measured in clause 7.2.2.1.

### 7.2.3 Limit

The measurement shall be carried out under normal conditions only.

The maximum effective radiated power under normal test conditions shall be within  $d_f$  from the rated effective radiated power.

The allowance for the characteristics of the equipment ( $\pm 1,5$  dB) shall be combined with the actual measurement uncertainty in order to provide  $d_f$ , as follows:

$$- d_f^2 = d_m^2 + d_e^2;$$

where:

- $d_m$  is the actual measurement uncertainty;
- $d_e$  is the allowance for the equipment (1,5 dB);
- $d_f$  is the final difference.

All values shall be expressed in linear terms.

In all cases the actual measurement uncertainty shall comply with clause 10.

Furthermore, the maximum effective radiated power shall not exceed the maximum value allowed by the administrations.

Example of the calculation of  $d_f$ :

- $d_m = 6$  dB (value acceptable, as indicated in the table of maximum uncertainties);
- $d_m = 3,98$  in linear terms;
- $d_e = 1,5$  dB (fixed value for all equipment fulfilling the requirements of the present document);
- $d_e = 1,41$  in linear terms;
- $d_f^2 = (3,98)^2 + (1,41)^2$ ; therefore,
- $d_f = 4,22$  in linear terms, or 6,25 dB.

This calculation shows that in this case  $d_f$  is in excess by 0,25 dB compared to  $d_m$ , the actual measurement uncertainty (6 dB).

## 7.3 Adjacent and alternate channels power

### 7.3.1 Definition

The adjacent channel power is that part of the total output power of a transmitter, under defined conditions of modulation, which falls within specified passbands centred on the nominal frequency of either of the adjacent channels.

The alternate channel power is that part of the total output power of a transmitter, under defined conditions of modulation, which falls within specified passbands centred on the nominal frequency of either of the alternate channels.

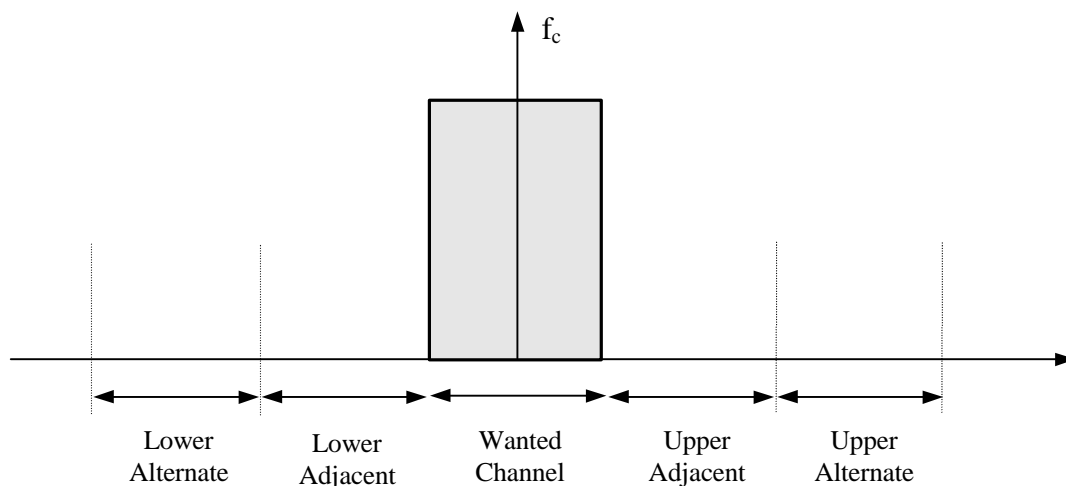

**Figure 3: Adjacent and alternate channel definitions**

These powers are the sum of the rms powers produced by the modulation, hum and noise of the transmitter.

### 7.3.2 Methods of measurement

The adjacent and alternate channel powers shall be measured with a spectrum analyser which conforms with the requirements given in annex B.

NOTE: Accredited test laboratories may use other equivalent techniques.

The transmitter shall be operated at the power determined in clauses 7.1.2 or 7.2.2 as appropriate, under normal test conditions, see clause 5.3.

The transmitter shall be modulated with test signal B1, M5 or M7 (as appropriate, see clause 6.1.1). The modulation used shall be recorded in the test report.

The output of the transmitter shall be connected to the input of the spectrum analyser by a 50  $\Omega$  power attenuator, to ensure that the impedance presented to the transmitter is 50  $\Omega$  and the level at the spectrum analyser input is appropriate.

The resolution bandwidth of the spectrum analyser shall be 100 Hz.

The rms power present in the nominal channel, measured on the spectrum analyser, shall be recorded (the wanted channel power, PR).

For the purpose of the remainder of this test the CBW shall be  $0,7 \times \text{CSP}$ . The CBW shall be centred one CSP above the centre of the nominal channel. The rms power present in the CBW shall be recorded (the adjacent channel power).

The measurement shall be repeated with the CBW centred one CSP below the centre of the nominal channel.

The measurement shall be made under normal test conditions (see clause 5.3) and repeated under extreme test conditions (see clauses 5.4.1 and 5.4.2 applied simultaneously).

Measurement under extreme conditions (see clause 5.4) may be omitted if the equipment is capable of testing for frequency stability and such tests are carried out under clause 7.7.

The adjacent channel power ratio is the difference (in dB) between the measured wanted channel power (PR) under normal test conditions and the largest adjacent channel power under normal and extreme test conditions.

Alternatively, if the spectrum analyser measures rms adjacent channel power automatically, the adjacent channel power (in dB) may be measured directly at normal and extreme test conditions. The analyser should use a analogue measurement method without frequency weighting and not using an accelerated method. The adjacent channel power ratio is the smaller of the measurement results under normal and extreme conditions.

The measurement shall be repeated with the CBW centred two CSP above the centre of the nominal channel. The measurement shall be repeated with the CBW centred two CSP below the centre of the nominal channel. The measurement shall be made under normal test conditions (see clause 5.3) and repeated under extreme test conditions (see clauses 5.4.1 and 5.4.2 applied simultaneously). Automatic measurement may also be used if supported by the spectrum analyser.

Measurement under extreme conditions (see clause 5.4) may be omitted if the equipment is capable of testing for frequency stability and such tests are carried out under clause 7.7.

The alternate channel power ratio is the difference (in dB) between the measured integrated wanted channel power under normal test conditions and the largest alternate channel power under normal and extreme test conditions.

### 7.3.3 Limit

The rms power in each adjacent channel shall not exceed a value of 60 dB below the rms power in the wanted channel (PR), measured under normal test conditions, see clause 5.3. The rms power in each adjacent channel shall not exceed a value of 55 dB below the rms power in the wanted channel (PR), measured under extreme test conditions, clause 5.4, without the need to be below 0,2  $\mu\text{W}$  (-37 dBm), under both normal and extreme conditions.

The rms power in each alternate channel, centred two CSP from the nominal channel centre, shall not exceed a value of 70 dB below the rms power (PR) measured under normal test conditions, clause 5.3. The power in each alternate channel, centred two CSP from the nominal channel centre, shall not exceed a value of 65 dB below the rms power (PR), measured under extreme test conditions, see clause 5.4, without the need to be below 0,2  $\mu\text{W}$  (-37 dBm), under both normal and extreme conditions.

Limits under extreme conditions (see clause 5.4) are not applicable if the equipment is capable of being tested for frequency stability and such tests are carried out under clause 7.7.

## 7.4 Spurious emissions

### 7.4.1 Definition

Spurious emissions are emissions on a frequency, or frequencies, which are outside the necessary bandwidth and the level of which may be reduced without affecting the corresponding transmission of information. Spurious emissions include harmonic emissions, parasitic emissions, intermodulation products and frequency conversion products but exclude out of band emissions. For the purpose of the present document the transition point between spurious emissions and out of band emissions is taken as 250 % of the CSP (see ITU-R Recommendation SM.329-7 [9]).

The level of spurious emissions shall be measured as:

- a) their mean power level in a specified load (conducted spurious emission);
- b) their mean effective radiated power when radiated by the cabinet and by the integral antenna, in the case of a handportable equipment fitted with such an antenna.

### 7.4.2 Method of measurement

#### 7.4.2.1 Method of measuring conducted spurious emissions in a specified load (clause 7.4.1 (a))

This method applies only to equipment with an external 50  $\Omega$  antenna connector.

Spurious emissions shall be measured as the mean power level of any signal delivered into a 50  $\Omega$  load. This may be done by connecting the transmitter output through an attenuator to either a spectrum analyser (see also annex B) or selective voltmeter or by monitoring the relative levels of the spurious signals delivered to an artificial antenna (see clause 6.2).

If possible the transmitter shall be unmodulated and the measurements made over the frequency range 9 kHz to 4 GHz for equipment operating on frequencies not exceeding 470 MHz or over the frequency range 9 kHz to 12,75 GHz for equipment operating on frequencies above 470 MHz, excluding the five contiguous channels centred on the channel on which the transmitter is intended to operate.

The measurement shall be repeated with the transmitter modulated by the test signal B1, M5 or M7 (as appropriate, see clause 6.1.1). If possible, the modulation should be continuous for the duration of the measurement.

As a general rule, the resolution bandwidth of the measuring receiver should be equal to the reference bandwidth as given in clause 7.4.3. To improve measurement accuracy, sensitivity and efficiency, the resolution bandwidth can be different from the reference bandwidth. When the resolution bandwidth is smaller than the reference bandwidth, the result should be integrated over the reference bandwidth. When the resolution bandwidth is greater than the reference bandwidth, the result for broadband spurious emissions should be normalized to the bandwidth ratio. For discrete spur, normalization is not applicable, while integration over the reference bandwidth is still applicable. The bandwidth used in this measurement for each spurious emission shall be sufficiently narrow to reject emissions in the five contiguous channels centred on the channel on which the transmitter is intended to operate. The conditions used in the relevant measurements shall be reported in the test report.

The measurement shall be repeated with the transmitter in the "stand-by" position.

#### 7.4.2.2 Method of measuring the effective radiated power (clause 7.4.1 (b))

This method applies only to equipment with an external antenna connected.

On a test site, selected from annex A, the equipment shall be placed at the specified height on a non-conducting support and in the position closest to normal use as declared by the manufacturer.

The transmitter antenna connector shall be connected to an artificial antenna (see clause 6.2).

The output of the test antenna shall be connected to a measuring receiver.

The test antenna shall be orientated for vertical polarization and the length of the test antenna shall be chosen to correspond to the instantaneous frequency of the measuring receiver.

The transmitter shall be switched on with C1 modulation, and the measuring receiver shall be tuned over the frequency range 30 MHz to 4 GHz, except for the five contiguous channels centred on the channel on which the transmitter is intended to operate. At each frequency at which a discrete spurious component is detected, the test antenna shall be raised and lowered through the specified range of heights until a maximum signal level is detected on the measuring receiver. The resolution bandwidth of the measuring instrument shall be the smallest bandwidth available which is greater than the spectral width of the spurious component being measured. This shall be considered to be achieved when the next highest bandwidth causes less than 1 dB increase in amplitude.

When a test site according to clause A.1.1 is used there is no need to vary the height of the antenna.

The transmitter shall then be rotated through 360° in the horizontal plane, until the maximum signal level is detected by the measuring receiver.

The measuring receiver shall measure the mean power and this power shall be noted. The horizontal and vertical orientation of the antenna shall also be noted.

The transmitter shall be replaced by a substitution antenna as defined in clause A.1.5.

The substitution antenna shall be orientated for vertical polarization and the length of the substitution antenna shall be adjusted to correspond to the frequency of the spurious component detected.

The substitution antenna shall be connected to a calibrated signal generator.

The frequency of the calibrated signal generator shall be set to the frequency of the spurious component detected.

The input attenuator setting of the measuring receiver shall be adjusted in order to increase the sensitivity of the measuring receiver, if necessary.

The test antenna shall be raised and lowered through the specified range of heights to ensure that the maximum signal is received.

When a test site according to clause A.1.1 is used there is no need to vary the height of the antenna.

The input signal to the substitution antenna shall be adjusted to the level that produced a level detected by the measuring receiver, that is equal to the level noted while the spurious component was measured, corrected for the change of input attenuator setting of the measuring receiver.

The input level to the substitution antenna shall be recorded as power level.

The measurement shall be repeated with the test antenna and the substitution antenna orientated for horizontal polarization.

The measure of the effective radiated power of the spurious components is the larger of the two power levels recorded for each spurious component at the input to the substitution antenna, corrected for the gain of the antenna if necessary.

The measurement shall be repeated with the transmitter modulated by the test signal B1, M5 or M7 (as appropriate, see clause 6.1.1). If possible, the modulation should be continuous for the duration of the measurement. When burst transmission is used, the mean power of any spurious emissions shall be measured using averaging over the duration of the burst.

The measurement shall be repeated with the transmitter in the "stand-by" position.

### 7.4.2.3 Method of measuring the effective radiated power (clause 7.4.1 (c))

This method applies only to equipment without an external 50 Ω antenna connector.

The method of measurement shall be performed according to clause 7.4.2.2, except that the transmitter output shall be connected to the integral antenna and not to an artificial antenna.

### 7.4.3 Limits

The power of any spurious emission, occurring more than  $2,5 \times$  CSP from the centre of the channel on which the transmitter is intended to operate, shall not exceed the values given in tables 1 and 2.

**Table 1: Conducted emissions**

Frequency range	9 kHz to 1 GHz	Above 1 GHz to 4 GHz, or above 1 GHz to 12,75 GHz (see clause 7.4.2)
Tx operating	0,25 $\mu$ W (-36,0 dBm)	1,0 $\mu$ W (-30,0 dBm)
Tx Standby	2,0 nW (-57,0 dBm)	20,0 nW (-47,0 dBm)

**Table 2: Radiated emissions**

Frequency range	30 MHz to 1 GHz	Above 1 GHz to 4 GHz
Tx operating	0,25 $\mu$ W (-36,0 dBm)	1,0 $\mu$ W (-30,0 dBm)
Tx Standby	2,0 nW (-57,0 dBm)	20,0 nW (-47,0 dBm)

In the case of radiated measurements for handportable stations the following conditions apply:

- internal integral antenna, the normal antenna shall be connected;
- external antenna socket, an artificial antenna shall be connected to the socket for the test.

The reference bandwidths used in clause 7.4.2.1 shall be as table 3.

**Table 3: Reference bandwidths to be used for the assessment of conformity with spurious emissions limits**

Frequency range (offset from channel centre)	Reference bandwidth below 1 GHz	Reference bandwidth above 1 GHz
250 % of the CSP to 250 kHz (see note)	1 kHz	1 kHz
250 kHz to 500 kHz	10 kHz	10 kHz
500 kHz to 1 MHz	100 kHz	300 kHz
> 1 MHz	100 kHz	1 MHz

NOTE: This breakpoint has been agreed with CEPT/ERC and is allowed until 2003. At this date, CEPT and ETSI will review, and if necessary revise, the standard in line with recommends 8 of the CEPT/ERC Recommendation on "Spurious Emissions" and the CEPT/ETSI MoU.

## 7.5 Intermodulation attenuation

This requirement applies only to transmitters to be used in base stations (fixed).

### 7.5.1 Definition

Intermodulation attenuation is the capability of a transmitter to avoid the generation of signals in the non-linear elements caused by the presence of the carrier and an interfering signal entering the transmitter via the antenna.

It is specified as the ratio, in dB, of the power level of the third order intermodulation product to the carrier power level.

## 7.5.2 Method of measurement

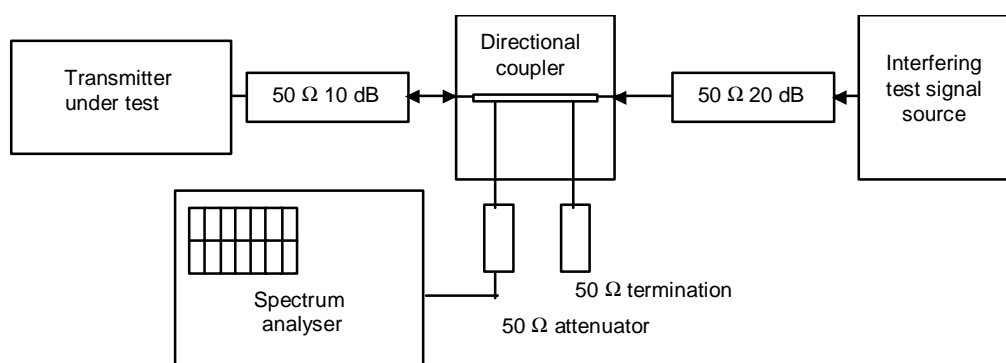

**Figure 4: Measurement arrangement**

The measurement arrangement shown in figure 4 shall be used.

NOTE: Accredited test laboratories may use other equivalent techniques.

The transmitter shall be connected to a 50 Ω, 10 dB attenuator and via a directional coupler to a spectrum analyser. An additional attenuator may be required between the directional coupler and the spectrum analyser to avoid overloading the spectrum analyser.

In order to reduce the influence of mismatch errors it is important that the 10 dB power attenuator is coupled to the transmitter under test with the shortest possible connection.

The interfering test signal source is connected to the other end of the directional coupler via a 50 Ω, 20 dB attenuator.

The interfering signal source may be either a transmitter providing the same power output as the transmitter under test and be of a similar type or a signal generator and a power amplifier of equivalent intermodulation attenuation as that required from the transmitter, capable of delivering the same output power as the transmitter under test. In either case the interfering signal source shall be capable of generating a CW signal at power level equivalent to PX.

The directional coupler shall have an insertion loss of less than 1 dB, a sufficient bandwidth and a directivity of more than 20 dB.

The transmitter under test and the test signal source shall be physically separated in such a way that the measurement is not influenced by direct radiation.

Prior to the measurement, the maximum power level, PX, of the transmitter under test shall be measured according to clause 7.1 and the value recorded.

For non-constant envelope modulation test signal B1, M5 or M7 (as appropriate, see clause 6.1.1) shall be applied at the transmitter. For constant envelope modulation schemes it is not required to apply modulation. The modulation used, if any shall be recorded in the test report. The spectrum analyser shall be adjusted to display the maximum signal level. The frequency scan width shall be 500 kHz.

The interfering test signal source shall be a CW signal at a frequency within 50 kHz to 100 kHz above the frequency of the transmitter under test.

The frequency shall be chosen in such a way that the intermodulation components to be measured do not coincide with other spurious components. The power output of the interfering test signal source shall be adjusted to the PX level recorded above, by the use of a power meter.

The intermodulation components shall be measured by direct observation on the spectrum analyser of the ratio of the largest third order intermodulation component with respect to the power level PX.

This measurement shall be repeated with the interfering test signal source at a frequency within 50 kHz to 100 kHz below the frequency of the transmitter under test.



### 7.5.3 Limits

This requirement applies only to transmitters to be used in base stations (fixed).

Two classes of transmitter intermodulation attenuation are defined, the equipment shall fulfil one of the following requirements:

- the intermodulation attenuation ratio shall be at least 40,0 dB for any intermodulation component;
- for base station equipment to be used in special service conditions (e.g. at sites where more than one transmitter will be in service) or when the regulatory authority makes it a condition of the licence, the intermodulation attenuation ratio shall be at least 70,0 dB for any intermodulation component. In the case where the performance is achieved by additional internal or external isolating devices (such as circulators) these shall be supplied at the time of type testing and shall be used for the measurements.

## 7.6 Transient power

### 7.6.1 Definition

Transients power is the power falling into adjacent spectrum due to switching the transmitter on and off.

### 7.6.2 Method of measurement

The transmitter under test shall be connected via the power attenuator to the "transient power measuring device" as described in clause 7.6.2.1, so that the level at its input is suitable, e.g. between 0 dBm and -10 dBm when the transmitter power is the steady state power.

For non-constant envelope modulation test signal B1, M5 or M7 (as appropriate, see clause 6.1.1) shall be applied at the transmitter. For constant envelope modulation schemes it is not required to apply modulation. The modulation used, if any, shall be recorded in the test report.

The measurement procedure shall be as follows:

- a) the transmitter shall be operated at the maximum rated carrier power level, under normal test conditions (see clause 5.3);
- b) the tuning of the "transient power measuring device" shall be tuned to the operating channel and adjusted so that a maximum response is obtained. This is the 0 dBc reference level; The transmitter shall then be switched off;
- c) the tuning of the "transient power measuring device" shall be adjusted away from the centre of the channel so that its -6 dB response nearest to the transmitter channel centre frequency is located at a displacement from the nominal carrier frequency of 8,25 kHz;
- d) the transmitter shall be switched on;
- e) the spectrum analyser shall be used to record the envelope of the transient power as a function of time (approximately 50 ms duration). The peak envelope transient power shall be noted in dBc;
- f) the transmitter shall be switched off;
- g) the spectrum analyser shall be used to record the envelope of the transient power as a function of time (approximately 50 ms duration). The peak envelope transient power shall be noted in dBc;
- h) steps d) to g) shall be repeated five times and the highest response during "switch-on" and "switch-off" conditions shall be recorded;
- i) steps c) to h) shall be repeated with the "transient power measuring device" tuned to the other side of the channel;
- j) steps c) to i) shall be repeated with the tuning of the "transient power measuring device" adjusted away from the centre of the channel so that its -6 dB response nearest to the transmitter channel centre frequency is located at a displacements from the nominal carrier frequency of 25 kHz, 100 kHz and 1 MHz;

- k) the adjacent channel transient is the dBc value corresponding to the highest of the values recorded in step h); this value shall be recorded.

### 7.6.2.1 Characteristics of the transient power measuring device

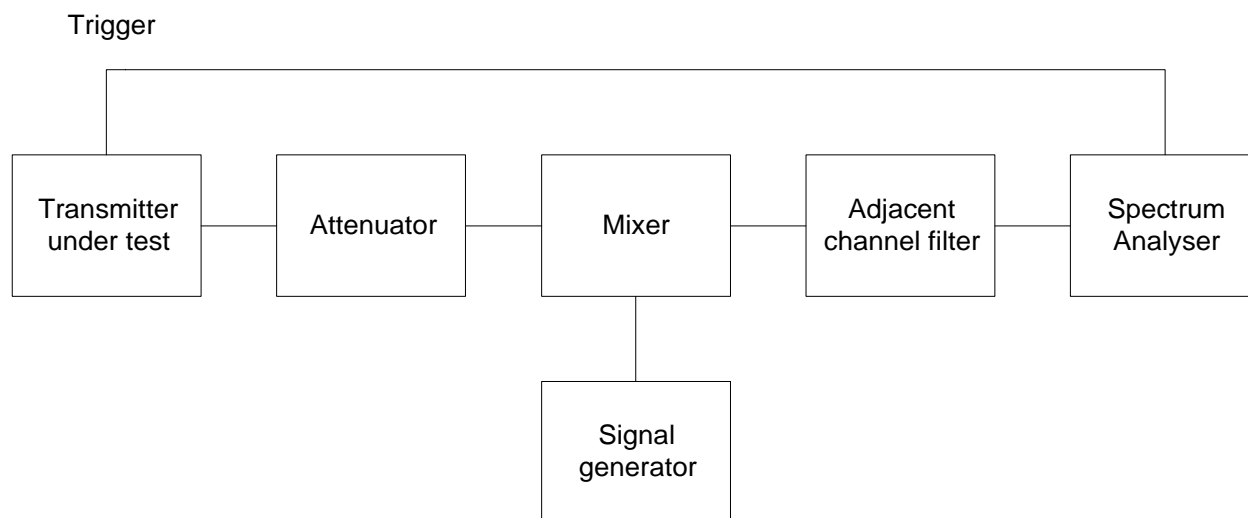

**Figure 5: Transient power measuring device measurement arrangement**

The adjacent channel transient power measuring device may be as follows:

- mixer: 50  $\Omega$  balanced diode mixer; with an appropriate local oscillator level, for example +7 dBm;
- adjacent channel filter: matched to 50  $\Omega$  (see annex D);
- spectrum analyser: 30 kHz bandwidth, peak detection, or power/time measurement provision.

### 7.6.3 Limits

The transient power in the adjacent channel shall not exceed a value of 50 dB below PX of the transmitter without the need to be below 2  $\mu$ W (-27,0 dBm).

For measurements at 100 kHz and 1 MHz the transient power shall not exceed 60 dB below PX of the transmitter without the need to be below 2  $\mu$ W (-27,0 dBm).

## 7.7 Frequency error

For equipment that can be measured for frequency error, under this clause, the manufacturer may choose to omit this test if the adjacent and alternate channel power is measured under extreme test conditions in clause 7.3.

### 7.7.1 Definition

The frequency error of the transmitter is the difference between the measured carrier frequency in the absence of modulation (or with modulation, provided that the presence of modulation allows sufficiently accurate measurement of the carrier frequency), and the nominal frequency of the transmitter.

## 7.7.2 Method of measurement

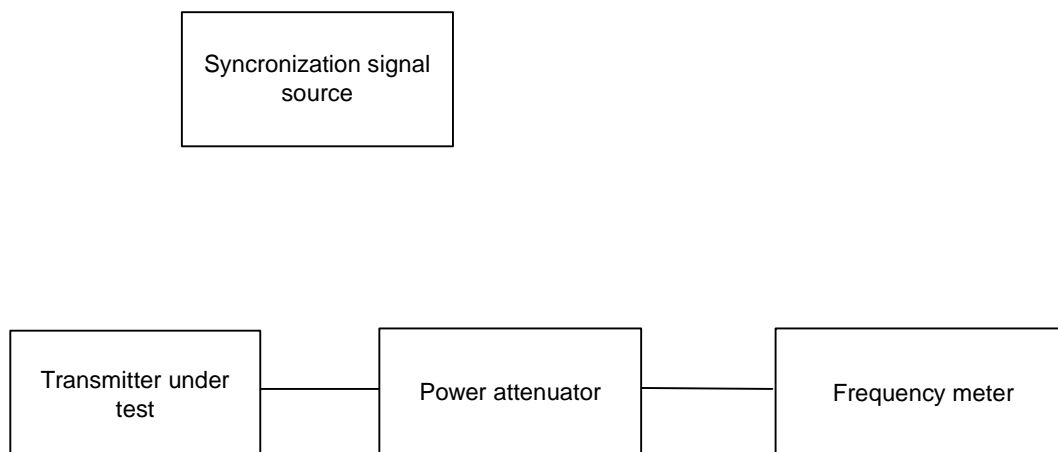

**Figure 6: Measurement arrangement**

The equipment shall be connected via the power attenuator to the frequency meter.

The carrier frequency shall be measured in the absence of modulation unless a particular signal exists that allows carrier frequency measurement. Such a signal shall be declared by the manufacturer. The measurement shall be made under normal test conditions (see clause 5.3) and extreme test conditions (see clauses 5.4.1 and 5.4.2 applied simultaneously).

For equipment that does not permit transmission without synchronizing to a base station the frequency accuracy of the transmitter shall be measured after the equipment has synchronized to a suitable signal, as specified by the manufacturer. Such equipment's shall prohibit start of transmission if synchronization has not been performed for greater than 1 minute prior to transmission.

Details of any synchronization signals used and timings of these signals shall be recorded in the test report.

## 7.7.3 Limits

The frequency error shall not exceed the values given in table 4, under normal and extreme test conditions, or in any intermediate set of conditions. However, for practical reasons the measurement shall be performed only at nominal and extreme test conditions.

**Table 4: Frequency error**

Frequency error limit				
Below 47 MHz	47 MHz to 137 MHz	Above 137 MHz to 300 MHz	Above 300 MHz to 500 MHz	Above 500 MHz
±0,30 kHz (B) ±0,1 CSP (M)	±0,30 kHz (B) ±0,1 CSP (M)	±0,30 kHz (B) ±0,1 CSP (M)	±0,50 kHz (B) ±0,1 CSP (M)	±0,50 kHz (B) ±0,1 CSP (M)
NOTE: For mobile and handportable equipment that is tested following synchronization (see clause 7.7.2) the frequency error shall at no time exceed the above limits up to 4 minutes after the start of transmission. For handportable equipment, these limits only apply to the reduced extreme temperature conditions 0 °C to +40 °C. (see clause 5.4.1). At severe extreme temperature conditions -20 °C to +55 °C the frequency limit is ± 0,25 CSP. (B) Base station. (M) Mobile station and handportable.				

---

## 8 Technical characteristics of the receiver

### 8.1 Maximum usable sensitivity (analogue, conducted)

This requirement applies only to equipment capable of analogue transmission.

#### 8.1.1 Definition

The maximum usable sensitivity (analogue) of the receiver is the minimum level of signal (emf) at the receiver input, produced by a carrier at the nominal frequency of the receiver, modulated with the receiver analogue test signal (see clause 6.1.2), which will, without interference, produce after demodulation:

- an audio frequency output power of at least 50 % of the rated power output (see clause 6.11); and
- a SINAD ratio of 20 dB, measured at the receiver output through a telephone psophometric weighting network as described in ITU-T Recommendation O.41 [10].

#### 8.1.2 Method of measuring the SINAD ratio

The measurement procedure shall be as follows:

- a) an input signal with a frequency equal to the nominal frequency of the receiver, modulated by the receiver analogue test signal (see clause 6.1.2), shall be applied to the receiver input terminals;
- b) the SINAD ratio shall be monitored;  
  
where possible, the receiver volume control shall be adjusted to give at least 50 % of the rated output power (see clause 6.11) or in the case of stepped volume controls, to the first step that provides an output power of at least 50 % of the rated power;
- c) the level of the signal generator shall be adjusted until a psophometrically weighted SINAD ratio (or its acoustic equivalent) of 20 dB is obtained;
- d) the test signal input level (PEP) under these conditions is the value of the maximum usable sensitivity;
- e) the measurement shall be made under normal test conditions (see clause 5.3) and repeated under extreme test conditions (see clauses 5.4.1 and 5.4.2 applied simultaneously).

#### 8.1.3 Limits

The maximum usable sensitivity shall not exceed an emf of 6,0 dB $\mu$ V under normal test conditions, and an emf of 12,0 dB $\mu$ V under extreme test conditions.

Under extreme test conditions, the receiver audio output power shall be within  $\pm 3,0$  dB of the value obtained under normal test conditions.

For equipment capable of duplex operation an additional requirement is contained in clause 9.1.3.

### 8.2 Maximum usable sensitivity (analogue, field strength)

This method applies only to equipment without an external antenna connector.

This requirement applies only to equipment capable of transmission of analogue information.

## 8.2.1 Definition

The maximum usable sensitivity (analogue) expressed as field strength is the field strength, expressed in  $\text{dB}\mu\text{V}/\text{m}$ , produced by a carrier at the nominal frequency of the receiver, modulated with the receiver analogue test signal (see clause 6.1.2) which will, without interference, produce after demodulation a SINAD ratio of 20 dB measured through a psophometric weighting network.

## 8.2.2 Method of measurement

Arrangements shall be made to couple the equipment under test to the SINAD meter by a method which does not affect the radiated field (see clause A.3.3).

A test site which fulfils the requirements for the specified frequency range of this measurement shall be used (see annex A).

The test antenna shall be orientated for the polarization specified by the manufacturer and the length of the test antenna shall be chosen to correspond to the frequency of the receiver.

The equipment shall be placed at the specified height on a non-conducting support, in the position closest to the normal use declared by the manufacturer. The position shall be recorded in the test report.

A distortion factor meter incorporating a 1 000 Hz band-stop filter (or a SINAD meter) shall be connected to the receiver output terminals via a psophometric filter and an audio frequency load or by an acoustic coupler (see clause A.3.3.1) in order to avoid disturbing the electromagnetic field in the vicinity of the equipment.

- a) a signal generator shall be connected to the test antenna;

the signal generator shall be at the nominal frequency of the receiver and shall be modulated by the receiver analogue test modulation (see clause 6.1.2);

- b) the SINAD ratio shall be monitored;

where possible, the receiver volume control shall be adjusted to give at least 50 % of the rated output power (see clause 6.11) or in the case of stepped volume controls, to the first step that provides an output power of at least 50 % of the rated power;

- c) the level of the signal generator shall be adjusted until a psophometrically weighted SINAD ratio (or its acoustic equivalent) of 20 dB is obtained;

- d) the test antenna shall be raised or lowered through the specified height range to find the best psophometrically weighted SINAD ratio (or its acoustic equivalent);

- e) the level of the signal generator shall be re-adjusted until a SINAD ratio of 20 dB is obtained;

- f) the minimum signal generator level from step e) shall be noted and maintained;

- g) the receiver shall then be replaced by a substitution antenna as defined in clause A.1.5;

the substitution antenna shall be orientated for the polarization of the test antenna and the length of the substitution antenna shall be adjusted to correspond to the frequency of the receiver;

- h) the substitution antenna shall be connected to a calibrated measuring receiver;

the test antenna shall be raised and lowered through the specified range of height to ensure that the maximum signal is received;

the test antenna need not be raised or lowered if the measurement is carried out on a test site according to clause A.1.1;

- i) the signal PEP measured with the calibrated measuring receiver shall be recorded as the field strength in dB $\mu$ V/m;

the measurement shall be repeated with the test antenna and the substitution antenna orientated for horizontal polarization;

the measure of the maximum usable sensitivity expressed as field strength is the minimum of the two signal levels recorded as the input to the calibrated measuring receiver, corrected for the gain of the antenna if necessary.

### 8.2.3 Limits

The maximum usable sensitivity shall not exceed the field strength value shown in table 5.

**Table 5: Maximum usable sensitivity (analogue)**

Frequency band (MHz)	Field strength in dB relative to 1 $\mu$ V/m
	Normal test conditions
30 to 100	14,0
100 to 230	20,0
230 to 470	26,0
470 to 3 000	32,0

## 8.3 Maximum usable sensitivity (data, conducted)

This requirement applies only to equipment capable of transmission of digital information.

For equipment that supports adaptive rates, testing is only required at two bit rates, the minimum bit rate supported by the equipment and the maximum bit rate that the manufacturer declares is compliant to the present document.

### 8.3.1 Definition

The maximum usable sensitivity (data) of the receiver is the minimum level of signal (emf) at the receiver input, at the nominal frequency of the receiver, with test signal M2 or M7 as appropriate (see clause 6.1.3), which without interference will produce after demodulation a data signal with a specified bit error ratio or a specified successful message ratio.

The specified bit error ratio is  $10^{-2}$ . The specified successful message ratio is 0,8.

### 8.3.2 Methods of measurement

#### 8.3.2.1 Method of measurement with continuous bit streams

The measurement procedure shall be as follows:

- an input signal with a centre frequency equal to the nominal centre frequency of the receiver, modulated by the test signal M2 (see clause 6.1.3) shall be applied to the receiver input terminals;
- the bit pattern of the modulating signal shall be compared to the bit pattern obtained from the receiver after demodulation;
- the emf of the input signal to the receiver is adjusted until the bit error ratio is  $10^{-2}$  or better (when the value of  $10^{-2}$  cannot be reached exactly, this shall be taken into account in the evaluation of the measurement uncertainty (ETR 028 [1]));
- the maximum usable sensitivity is the emf of the signal at the input of the receiver;
- the measurement shall be made under normal test conditions (see clause 5.3) and repeated under extreme test conditions (see clauses 5.4.1 and 5.4.2 applied simultaneously).

### 8.3.2.2 Method of measurement with messages

In the case where operation using a continuous bit stream is not possible, the following method of measurement shall be applied.

- a) a signal with a centre frequency equal to the nominal centre frequency of the receiver and modulated with the test signal M6 (see clauses 6.1.3 and 6.4) in accordance with instructions of the manufacturer (and approved by the accredited test laboratory) shall be applied to the receiver input terminals;
- b) the level of this signal shall be such that a successful message rate of less than 10 % is obtained;
- c) the test signal M6 shall be transmitted repeatedly whilst observing in each case whether or not a successful response is obtained;  
 the input level shall be increased by 2 dB for each occasion that a successful response is not obtained;  
 the procedure shall be continued until three consecutive successive responses are observed;  
 the level of the input signal shall be noted;
- d) the input signal level shall be reduced by 1 dB and the new value noted;  
 the normal test signal shall then be transmitted 20 times. In each case, if a response **is not** obtained the input level shall be increased by 1 dB and the new value noted;  
 if a message is successfully received, the level of the input shall not be changed until three consecutive messages have been successfully received. In this case, the input level shall be reduced by 1 dB and the new value noted;  
 no level of the input signal shall be noted unless preceded by a change in level;
- e) the maximum usable sensitivity is the average of the values recorded in steps c) and d) (which provides the level corresponding to the successful message ratio of 80 %); this value shall be recorded;
- f) the measurement shall be made under normal test conditions (see clause 5.3) and repeated under extreme test conditions (see clauses 5.4.1 and 5.4.2 applied simultaneously).

### 8.3.3 Limits

The maximum usable sensitivity shall not exceed an emf of 3,0 dB $\mu$ V under normal test conditions and 9,0 dB $\mu$ V under extreme test conditions for equipment operating with data rates of up to 2 400 bits per second.

The maximum usable sensitivity shall not exceed an emf of 6,0 dB $\mu$ V under normal test conditions and 12,0 dB $\mu$ V under extreme test conditions for equipment operating with data rates between 2 401 bits per second and 4 800 bits per second.

The maximum usable sensitivity shall not exceed an emf of 9,0 dB $\mu$ V under normal test conditions and 15,0 dB $\mu$ V under extreme test conditions for equipment operating with data rates between 4 801 bits per second and 9 600 bits per second.

The maximum usable sensitivity shall not exceed an emf of 15,0 dB $\mu$ V under normal test conditions and 21,0 dB $\mu$ V under extreme test conditions for equipment operating with data rates above 9 600 bits per second.

For equipment capable of duplex operation an additional requirement is contained in clause 9.1.3.

## 8.4 Maximum usable sensitivity (data, field strength)

This requirement applies only to equipment capable of transmission of digital information.

This measurement applies only for equipment without an external antenna connector.

For equipment that supports adaptive rates, testing is only required at two bit rates, the minimum bit rate supported by the equipment and the maximum bit rate that the manufacturer declares is compliant to the present document.

### 8.4.1 Definition

The maximum usable sensitivity (data) expressed as field strength is the field strength, expressed in dB $\mu$ V/m, produced by a carrier at the nominal frequency of the receiver, modulated with the test signal M2 or M6 (see clause 6.1.3) which will, without interference, produce after demodulation a data signal with a specified bit error ratio or a specified successful message ratio.

The specified bit error ratio is  $10^{-2}$ . The specified successful message ratio is 0,8.

### 8.4.2 Method of measurement

The manufacturer shall specify the polarization of the RF field for which the equipment has been designed.

Three test scenarios are possible:

- a) the manufacturer declares the direction corresponding to the maximum usable sensitivity. In this case this position is used to perform the measurement in clauses 8.4.2.1 or 8.4.2.2;
- b) if the manufacturer does not declare the position corresponding to the maximum usable sensitivity but provides an analogue output according to clauses 6.12.1, then this output will be used to determine the direction of maximum usable sensitivity. This will be the position used for the measurement in clauses 8.4.2.1 or 8.4.2.2;
- c) if the direction corresponding to the maximum usable sensitivity cannot be determined as specified in a) or b) above, then an initial position will be used and the measurement in clauses 8.4.2.1 or 8.4.2.2 will be repeated with eight positions, 45° apart. The maximum usable sensitivity will be determined from the minimum field strength recorded.

#### 8.4.2.1 Method of measurement with continuous bit streams

Arrangements shall be made by the manufacturer to couple the equipment under test to the bit error measuring device by a method which does not affect the radiated field (see also clauses 6.12.2 and 6.12.3.1).

A test site which fulfils the requirements for the specified frequency range of this measurement shall be used (see annex A).

The test antenna shall be orientated for the polarization specified by the manufacturer and the length of the test antenna shall be chosen to correspond to the frequency of the receiver.

The equipment shall be placed at the specified height on a non-conducting support, in the position determined in clause 8.4.2. The position shall be recorded in the test report.

The raw bit stream produced by the receiver shall be monitored, preferably via a photo detector or an acoustic coupler in order to avoid disturbing the electromagnetic field in the vicinity of the equipment.

- a) a signal generator shall be connected to the test antenna;  
the signal generator shall be at the nominal frequency of the receiver and shall have the test signal M2 (see clause 6.1.3);
- b) the bit pattern of the modulating signal shall be compared to the bit pattern provided by the receiver after demodulation, in order to obtain the bit error ratio;
- c) the level of the signal generator shall be adjusted until a bit error ratio of approximately  $10^{-1}$  is obtained;
- d) the test antenna shall be raised or lowered through the specified height range to find the lowest bit error ratio;  
the test antenna may not need to be raised or lowered if a test site according to clause A.1.1 is used, or if the ground floor reflection can effectively be eliminated;
- e) the level of the signal generator shall be re-adjusted until a bit error ratio of  $10^{-2}$  is obtained; the input signal level to the test antenna shall be noted and maintained;



- f) the receiver shall then be replaced by a substitution antenna as defined in clause A.1.5;
- the substitution antenna shall be orientated for the polarization of the test antenna and the length of the substitution antenna shall be adjusted to correspond to the frequency of the receiver;
- g) the substitution antenna shall be connected to a calibrated measuring receiver;
- the test antenna shall be raised and lowered through the specified range of height to ensure that the maximum signal is received;
- the test antenna need not be raised or lowered if the measurement is carried out on a test site according to clause A.1.1;
- h) the measured signal level shall be recorded as field strength in dB $\mu$ V/m, this is the maximum usable sensitivity, corresponding to the direction used.

#### 8.4.2.2 Method of measurement with messages

In the case where operation using a continuous bit stream is not possible, the following method of measurement shall be applied.

Arrangements shall be made by the manufacturer to couple the equipment under test to the message measuring device by a method which does not affect the radiated field (see clause 6.12.3.2).

A test site which fulfils the requirements for the specified frequency range of this measurement shall be used (see annex A).

The test antenna shall be orientated for the polarization specified by the manufacturer and the length of the test antenna shall be chosen to correspond to the frequency of the receiver.

The equipment shall be placed at the specified height on a non-conducting support, in the position determined in clause 8.4.2. The position shall be recorded in the test report.

A message measuring device shall be coupled to the receiver, preferably via a photo detector or an acoustic coupler in order to avoid disturbing the electromagnetic field in the vicinity of the equipment.

- a) a signal generator shall be connected to the test antenna;
- the signal generator shall be at the nominal frequency of the receiver and shall have the test signal M6 (see clause 6.1.3);
- b) the level of the signal generator shall be adjusted until a successful message ratio of less than 10 % is obtained;
- c) the test antenna shall be raised or lowered through the specified height range to find the maximum successful message ratio;
- the test antenna may not need to be raised or lowered if a test site according to clause A.1.1 is used, or if the ground floor reflection can effectively be eliminated;
- the level of the test signal shall be re-adjusted to produce the successful message ratio specified in step b);
- d) the minimum signal generator level from step c) shall be noted;
- e) the test signal M6 shall be transmitted repeatedly whilst observing in each case whether or not a message is successfully received;
- the level of the test signal shall be increased by 2 dB for each occasion that a message is not successfully received;
- the procedure shall be continued until three consecutive messages are successfully received;
- this level as the minimum signal generator level in this direction shall be noted;

- f) the level of the test signal shall be reduced by 1 dB and the new value shall also be noted;
- the test signal M6 (see clause 6.1.3) shall then be transmitted 20 times. In each case, if a message is not successfully received, the level shall be increased by 1 dB and the new value noted;
- if a message is successfully received, the level shall not be changed until three consecutive messages have been successfully received;
- in this case, the level shall be reduced by 1 dB and the new value noted;
- no signal level shall be noted unless preceded by a change in level;
- the average of the values noted in steps e) and f) corresponds to the successful message ratio of 80 %; this input signal level to the test antenna shall be noted and maintained;
- g) the receiver shall then be replaced by a substitution antenna as defined in clause A.1.5;
- the substitution antenna shall be orientated for the polarization of the test antenna and the length of the substitution antenna shall be adjusted to correspond to the frequency of the receiver;
- h) the substitution antenna shall be connected to a calibrated measuring receiver;
- the test antenna shall be raised and lowered through the specified range of height to ensure that the maximum signal is received;
- the test antenna need not be raised or lowered if the measurement is carried out on a test site according to clause A.1.1;
- i) the measured signal level shall be recorded as field strength in dB $\mu$ V/m, this is the maximum usable sensitivity, corresponding to the direction used.

### 8.4.3 Limits

The maximum usable sensitivity shall not exceed the field strength value shown in table 6.

**Table 6: Maximum usable sensitivity (data)**

Frequency band (MHz)	Data Rate	Field strength in dB relative to 1 $\mu$ V/m (Normal test conditions)
30 to 100	Up to 2 400 bits per second	11 dB
	Between 2 401 bits per second and 4 800 bits per second	14 dB
	Between 4 801 bits per second and 9 600 bits per second	17 dB
	Above 9 601 bits per second	23 dB
100 to 230	Up to 2 400 bits per second	17 dB
	Between 2 401 bits per second and 4 800 bits per second	20 dB
	Between 4 801 bits per second and 9 600 bits per second	23 dB
	Above 9 601 bits per second	29 dB
230 to 470	Up to 2 400 bits per second	23 dB
	Between 2 401 bits per second and 4 800 bits per second	26 dB
	Between 4 801 bits per second and 9 600 bits per second	29 dB
	Above 9 601 bits per second	35 dB
470 to 3 000	Up to 2 400 bits per second	29 dB
	Between 2 401 bits per second and 4 800 bits per second	32 dB
	Between 4 801 bits per second and 9 600 bits per second	35 dB
	Above 9 601 bits per second	41 dB

## 8.5 Adjacent channel selectivity

### 8.5.1 Definition

The adjacent channel selectivity is the measure of the capability of the receiver to receive a wanted modulated signal at the nominal frequency without exceeding a given degradation due to the presence of an unwanted signal which differs in frequency from the wanted signal by an amount equal to the adjacent CSP for which the equipment is intended.

### 8.5.2 Method of measurement

The CSP of the equipment shall be declared by the manufacturer.

For digital equipment that supports adaptive rates, testing is only required at the maximum bit rate that the manufacturer declares is compliant to the present document.

#### 8.5.2.1 Method of measurement (analogue)

The measurement procedure shall be as follows:

- a) two signal generators, A and B, shall be connected to the receiver via a combining network (see clause 6.9);  
the wanted signal, provided by signal generator A, shall be at the nominal frequency of the receiver and shall have receiver analogue test modulation, (see clause 6.1.2);  
the unwanted signal, provided by signal generator B, shall be modulated test signal M4 (see clause 6.1.3) and shall be at the frequency of the channel immediately above that of the wanted signal;
- b) initially, signal generator B (unwanted signal) shall be switched off (maintaining the output impedance);  
the level of the wanted signal from generator A shall be adjusted to the level which is the value of the limit for the maximum usable sensitivity (i.e. 6 dB above 1  $\mu$ V emf under normal test conditions);  
where possible, the receiver volume control shall be adjusted to give at least 50 % of the rated output power (see clause 6.11) or, in the case of stepped volume controls, to the first step that provides an output power of at least 50 % of the rated output power. The obtained audio output level shall be noted;
- c) the unwanted signal from generator B shall then be switched on;
- d) the level of generator B shall be adjusted so that the unwanted signal causes:
  - a reduction of 3 dB in the output level of the wanted signal; or
  - a reduction to 14 dB of the SINAD ratio at the receiver output (with a psophometric filter), whether or not measured acoustically;whichever occurs first;
- e) the level of the unwanted signal shall be noted;
- f) for each adjacent channel, the selectivity shall be expressed as the ratio, in dB, of the level of the unwanted signal to the level of the wanted signal, at the receiver input; this ratio shall be recorded;
- g) the measurement shall be repeated with the unwanted signal at the frequency of the channel below that of the wanted signal;
- h) the adjacent channel selectivity of the equipment under test shall be expressed as the lower of the two values measured in the upper and lower channels nearest to the receiving channel (see step f above);
- i) the measurement shall be repeated under extreme test conditions (see clauses 5.4.1 and 5.4.2 applied simultaneously), with the level of the wanted signal adjusted to the level which is 6 dB above the value of the limit for the maximum usable sensitivity (i.e. 12 dB above 1  $\mu$ V emf).

### 8.5.2.2 Method of measurement (data with continuous bit stream)

The measurement procedure shall be as follows:

- a) two signal generators, A and B, shall be connected to the receiver via a combining network (see clause 6.9);  
the wanted signal, provided by signal generator A, shall be at the nominal frequency of the receiver and shall be modulated by the test signal M2 (see clause 6.1.3);  
the unwanted signal, provided by signal generator B, shall be modulated test signal M4 (see clause 6.1.3) and shall be at the frequency of the channel immediately above that of the wanted signal;
- b) initially, signal generator B (unwanted signal) shall be switched off (maintaining the output impedance);  
the level of the wanted signal from generator A shall be adjusted to the level which is 3 dB above the relevant limit in clause 8.3.3, at the receiver input terminals;
- c) signal generator B shall then be switched on, and the level of the unwanted signal adjusted until a bit error ratio of  $10^{-1}$  or worse is obtained;
- d) the test signal M2 shall be transmitted whilst observing the bit error ratio;
- e) the level of the unwanted signal shall be reduced in steps of 1 dB until a bit error ratio of  $10^{-2}$  or better is obtained. The level of the unwanted signal shall then be noted;
- f) for each adjacent channel, the selectivity shall be expressed as the ratio, in dB, of the level of the unwanted signal to the level of the wanted signal, at the receiver input. This ratio shall be recorded;
- g) the measurement shall be repeated with the unwanted signal at the frequency of the channel below that of the wanted signal;
- h) the adjacent channel selectivity of the equipment under test shall be expressed as the lower of the two values measured in the upper and lower channels nearest to the receiving channel (see step f) above);
- i) the measurement shall be repeated under extreme test conditions (see clauses 5.4.1 and 5.4.2 applied simultaneously), with the amplitude of the wanted test signal adjusted to an emf 9 dB above the relevant limit in clause 8.3.3, unless analogue selectivity measurements were made, in which case the selectivity (data) has to be measured only under normal test conditions.

### 8.5.2.3 Method of measurement with messages

In the case where operation using a continuous bit stream is not possible, the following method of measurement shall be applied.

The measurement procedure shall be as follows:

- a) two signal generators, A and B, shall be connected to the receiver via a combining network (see clause 6.9);  
the wanted signal, provided by signal generator A, shall be at the nominal frequency of the receiver and shall have test signal M6 (see clause 6.1.3);  
the unwanted signal, provided by signal generator B, shall be modulated test signal M4 (see clause 6.1.3) and shall be at the frequency of the channel immediately above that of the wanted signal;
- b) initially, signal generator B (unwanted signal) shall be switched off (maintaining the output impedance);  
the level of the wanted signal from generator A shall be adjusted to the level which is 3 dB above the relevant limit in clause 8.3.3, at the receiver input terminals;
- c) signal generator B shall then be switched on, and the level of the unwanted signal adjusted until a successful message ratio of less than 10 % is obtained;

- d) the test signal M6 (see clause 6.1.3) shall then be transmitted repeatedly whilst observing in each case whether or not a message is successfully received;

the level of the unwanted signal shall be reduced by 2 dB for each occasion that a message is not successfully received;

the procedure shall be continued until three consecutive messages are successfully received. The level of the input signal shall then be noted;

- e) the level of the unwanted signal shall be increased by 1 dB and the new value noted;

the normal test signal (see clause 7.3) shall then be transmitted 20 times. In each case, if a message is not successfully received the level of the unwanted signal shall be reduced by 1 dB and the new value noted;

if a message is successfully received, the level of the unwanted signals shall not be changed until three consecutive messages have been successfully received. In this case the unwanted signal shall be increased by 1 dB and the new value noted;

no level of the unwanted signal shall be noted unless preceded by a change in level;

the average of the values noted in steps d) and e) (which provides the level corresponding to the successful message ratio of 80 %) shall be noted;

- f) for each adjacent channel, the selectivity shall be expressed as the ratio, in dB, of the level of the unwanted signal to the level of the wanted signal, at the receiver input. This ratio shall be recorded;
- g) the measurement shall be repeated with the unwanted signal at the frequency of the channel below that of the wanted signal;
- h) the adjacent channel selectivity of the equipment under test shall be expressed as the lower of the two values measured in the upper and lower channels nearest to the receiving channel (see step f) above);
- i) the measurement shall be repeated under extreme test conditions (see clauses 5.4.1 and 5.4.2 applied simultaneously), with the amplitude of the wanted test signal adjusted to an emf 9 dB above in clause 8.3.3, unless analogue selectivity measurements were made, in which case the selectivity (data) has to be measured only under normal test conditions.

### 8.5.3 Limits

The minimum adjacent channel rejection shall be:

- 60 dB for mobile and base station equipment under normal test conditions and 50 dB under extreme test conditions;
- 50 dB for handportable equipment under normal test conditions and 40 dB under extreme test conditions.

## 8.6 Spurious response rejection

Spurious responses may occur at all frequencies throughout the frequency spectrum and the requirements of the present document shall be met for all frequencies. However, for practical reasons the measurements for type testing shall be performed as specified in the present document. More specifically, this method of measurement is not intended to capture all spurious responses but selects those that have a high probability of being present. However, in a limited frequency range close to the nominal frequency of the receiver, it has been considered impossible to determine the probability of a spurious response and therefore a search shall be performed over this limited frequency range. This method provides a high degree of confidence that the equipment also meets the requirements at frequencies not being measured.

For digital equipment that supports adaptive rates, testing is only required at the maximum bit rate that the manufacturer declares is compliant to the present document.

## 8.6.1 Definition

The spurious response rejection is a measure of the capability of the receiver to receive a wanted modulated signal without exceeding a given degradation due to the presence of an unwanted modulated signal at any other frequency, at which a response is obtained.

## 8.6.2 Method of measurement

### 8.6.2.1 Introduction to the method of measurement

To determine the frequencies at which spurious responses can occur the following calculations shall be made:

a) calculation of the "limited frequency range":

- the limited frequency range is defined as the frequency of the local oscillator signal ( $f_{LO}$ ) applied to the first mixer of the receiver plus or minus the sum of the intermediate frequencies ( $f_{I1}, \dots, f_{In}$ ) and a half the (SR) of the receiver (see clause 4);
- hence, the frequency  $f_l$  of the limited frequency range is:

$$f_{LO} - \sum_{j=1}^{j=n} f_{Ij} - \frac{SR}{2} \leq f_l \leq f_{LO} + \sum_{j=1}^{j=n} f_{Ij} + \frac{SR}{2}$$

b) calculation of frequencies outside the limited frequency range:

- a calculation of the frequencies at which spurious responses can occur outside the range determined in a) is made for the remainder of the frequency range of interest, as appropriate (see clauses 8.6.2.3, 8.6.2.4 and 8.6.2.5);
- the frequencies outside the limited frequency range are equal to the harmonics of the frequency of the local oscillator signal ( $f_{LO}$ ) applied to the first mixer of the receiver plus or minus the first intermediate frequency ( $f_{I1}$ ) of the receiver;
- hence, the frequencies of these spurious responses are:

$$n f_{LO} \pm f_{I1}$$

- where n is an integer greater than or equal to 2;

the measurement of the first image response of the receiver shall initially be made to verify the calculation of spurious response frequencies.

For the calculations a) and b) above, the manufacturer shall state the frequency of the receiver, the frequency of the local oscillator signal ( $f_{LO}$ ) applied to the 1st mixer of the receiver, the intermediate frequencies ( $f_{I1}, f_{I2}$  etc.), and the SR of the receiver.

### 8.6.2.2 Method of search over the "limited frequency range"

The measurement procedure shall be as follows:

a) two signal generators, A and B, shall be connected to the receiver via a combining network (see clause 6.9);

the wanted signal, provided by signal generator A, shall be at the nominal frequency of the receiver and shall have the appropriate test signal (see clauses 6.1.2 and 6.1.3);

the unwanted signal, provided by signal generator B, shall be modulated with test signal M3 (see clause 6.1.3);

- b) initially, signal generator B (unwanted signal) shall be switched off (maintaining the output impedance);
- the level of the wanted signal from generator A shall be adjusted to the level which is 3 dB above the appropriate limit of the maximum usable sensitivity as specified in clauses 8.1 or 8.3.3;
- in the case where a continuous bit stream is used, the bit error ratio of the receiver after demodulation shall be noted;
- c) signal generator B shall then be switched on, and the level of the unwanted signal adjusted to 86 dB $\mu$ V at the receiver input terminals;
- the frequency of the unwanted signal generator shall be varied in increments of 50 % of the CSP of the equipment, over the limited frequency range (see clause 8.6.2.1 a)) and over the frequencies in accordance with the calculations outside of this frequency range (see clause 8.6.2.1 b));
- d) the frequency of any spurious response detected (e.g. by an increase in the previously noted bit error ratio or degradation of SINAD) during the search shall be recorded for use in the measurements in accordance with clauses 8.6.2.3, 8.6.2.4 and 8.6.2.5;
- e) in the case of digital equipment where operation using a continuous bit stream is not possible a similar method shall be used. In such case, instead of identifying a spurious response by noting an increase in the bit error ratio, spurious responses shall be identified by a degradation of the successful message ratio.

### 8.6.2.3 Method of measurement (analogue)

The measurement shall be performed as follows:

- a) two signals generators, A and B, shall be connected to the receiver via a combining network (see clause 6.9);
- the wanted signal, provided by signal generator A, shall be at the nominal frequency of the receiver and shall have receiver analogue test modulation, (see clause 6.1.2);
- the unwanted signal, provided by signal generator B, shall be modulated with test signal M3 (see clause 6.1.3), and shall be at the frequency of that spurious response being considered;
- b) initially, signal generator B (unwanted signal) shall be switched off (maintaining the output impedance);
- the level of the wanted signal from generator A shall be adjusted to the level which is the value of the limit for the maximum usable sensitivity (i.e. 6 dB above 1  $\mu$ V emf under normal test conditions);
- where possible, the receiver volume control shall be adjusted to give at least 50 % of the rated output power (see clause 6.11) or, in the case of stepped volume controls, to the first step that provides an output power of at least 50 % of the rated output power. The obtained audio output level shall be noted;
- c) the unwanted signal from generator B shall then be switched on;
- d) the level of generator B shall be adjusted so that the unwanted signal causes:
- a reduction of 3 dB in the output level of the wanted signal; or
  - a reduction to 14 dB of the SINAD ratio at the receiver output (with a psophometric filter), whether or not measured acoustically;
- whichever occurs first;
- e) the level of the unwanted signal shall be noted;
- f) the frequency of the unwanted signal shall be stepped up and down in increments of 20 % of the CSP and steps d) and e) shall be repeated until the lowest level noted in step e) is obtained; this value shall be recorded;

- g) the measurement shall be repeated at all spurious response frequencies found during the search over the "limited frequency range" (see clause 9.7.2 a)) and at frequencies calculated for the remainder of the spurious response frequencies (see clause 9.7.2 b)) in the frequency range from 100 kHz to 2 GHz for equipment operating on frequencies not exceeding 470 MHz or in the frequency range 100 kHz to 4 GHz for equipment operating above 470 MHz;
- h) the spurious response rejection of the equipment under test shall be expressed as the lowest value recorded in step f).

#### 8.6.2.4 Method of measurement (data with continuous bit streams)

The measurement shall be performed as follows:

- a) two signals generators, A and B, shall be connected to the receiver via a combining network (see clause 6.9);  
the wanted signal, provided by signal generator A, shall be at the nominal frequency of the receiver and shall be modulated by the test signal M2 (see clause 6.1.3);  
the unwanted signal, provided by signal generator B, shall be modulated with test signal M3 (see clause 6.1.3), and shall be at the frequency of that spurious response being considered;
- b) initially, signal generator B (unwanted signal) shall be switched off (maintaining the output impedance);  
the level of the wanted signal from generator A shall be adjusted to the level which is 3 dB above the relevant limit in clause 8.3.3, at the receiver input terminals;
- c) signal generator B shall then be switched on, and the level of the unwanted signal adjusted until a bit error ratio of  $10^{-1}$  or worse is obtained;
- d) the normal test signal M2 shall be transmitted whilst observing the bit error ratio;
- e) the level of the unwanted signal shall be reduced in steps of 1 dB until a bit error ratio of  $10^{-2}$  or better is obtained. The level of the unwanted signal shall then be noted;
- f) the frequency of the unwanted signal shall be stepped up and down in increments of 20 % of the CSP and step e) shall be repeated until the lowest level noted in step e) is obtained; this value shall be recorded;
- g) the measurement shall be repeated at all spurious response frequencies found during the search over the "limited frequency range" (see clause 9.7.2 a)) and at frequencies calculated for the remainder of the spurious response frequencies (see clause 9.7.2 b)) in the frequency range from 100 kHz to 2 GHz for equipment operating on frequencies not exceeding 470 MHz or in the frequency range 100 kHz to 4 GHz for equipment operating above 470 MHz;
- h) the spurious response rejection of the equipment under test shall be expressed as the lowest value recorded in step f).

#### 8.6.2.5 Method of measurement (data with messages)

In the case where operation using a continuous bit stream is not possible, the following method of measurement shall be applied.

The measurement shall be performed as follows:

- a) two signal generators, A and B, shall be connected to the receiver via a combining network (see clause 6.9);  
the wanted signal, provided by signal generator A, shall be at the nominal frequency of the receiver and shall be modulated by the test signal M6 (see clause 6.1.3);  
the unwanted signal, provided by signal generator B, shall be modulated with test signal M3 (see clause 6.1.3), and shall be at the frequency of that spurious response being considered;
- b) initially, signal generator B (unwanted signal) shall be switched off (maintaining the output impedance);  
the level of the wanted signal from generator A shall be adjusted to the level which is 3 dB above the relevant limit in clause 8.3.3, at the receiver input terminals;



- c) signal generator B shall then be switched on, and the level of the unwanted signal adjusted until a successful message ratio of less than 10 % is obtained;
- d) the test signal M6 (see clause 6.1.3) shall then be transmitted repeatedly whilst observing in each case whether or not a message is successfully received;
 

the level of the unwanted signal shall be reduced by 2 dB for each occasion that a message is not successfully received;

the procedure shall be continued until three consecutive messages are successfully received. The level of the input signal shall then be noted;
- e) the level of the unwanted signal shall be increased by 1 dB and the new value noted;
 

the test signal M6 (see clause 6.1.3) shall then be transmitted 20 times. In each case, if a message is not successfully received the level of the unwanted signal shall be reduced by 1 dB and the new value noted;

if a message is successfully received, the level of the unwanted signal shall not be changed until three consecutive messages have been successfully received. In this case the unwanted signal shall be increased by 1 dB and the new value noted;

no level of the unwanted signal shall be noted unless preceded by a change in level;

the average of the values noted in steps d) and e) (which provides the level corresponding to the successful message ratio of 80 % shall be noted;
- f) the frequency of the unwanted signal shall be stepped up and down in increments of 20 % of the CSP and steps d) and e) shall be repeated until the lowest level noted in step e) is obtained. This value shall be recorded;
- g) the measurement shall be repeated at all spurious response frequencies found during the search over the "limited frequency range" (see clause 9.7.2 a)) and at frequencies calculated for the remainder of the spurious response frequencies (see clause 9.7.2 b)) in the frequency range from 100 kHz to 2 GHz for equipment operating on frequencies not exceeding 470 MHz or in the frequency range 100 kHz to 4 GHz for equipment operating above 470 MHz;
- h) the spurious response rejection of the equipment under test shall be expressed as the lowest value recorded in step f).

### 8.6.3 Limits

At any frequency separated from the nominal frequency of the receiver by two channels or more, the spurious response rejection shall be such that under the specified test conditions, the given degradation shall not be exceeded for levels of the unwanted signal up to 76,0 dB $\mu$ V.

## 8.7 Intermodulation response rejection

For digital equipment that supports adaptive rates, testing is only required at the maximum bit rate that the manufacturer declares is compliant to the present document.

### 8.7.1 Definition

The intermodulation response rejection is a measure of the capability of the receiver to receive a wanted modulated signal, without exceeding a given degradation due to the presence of two or more unwanted signals with a specific frequency relationship to the wanted signal frequency.

## 8.7.2 Method of measurement

### 8.7.2.1 Method of measurement (analogue)

The measurement procedure shall be as follows:

- a) three signal generators, A, B and C, shall be connected to the receiver via a combining network (see clause 6.9);  
the wanted signal, provided by signal generator A, shall be at the nominal frequency of the receiver and shall have receiver analogue test modulation, (see clause 6.1.2);  
the first unwanted signal, provided by signal generator B, shall be unmodulated and adjusted to a frequency 25 kHz above the nominal frequency of the receiver;  
the second unwanted signal, provided by signal generator C, shall be modulated with test signal M3 (see clause 6.1.3) and adjusted to a frequency 50 kHz above the nominal frequency of the receiver;
- b) initially, signal generators B and C (unwanted signals) shall be switched off (maintaining the output impedance);  
the level of the wanted signal from generator A shall be adjusted to the level which is the value of the limit for the maximum usable sensitivity (i.e. 6 dB above 1  $\mu$ V emf under normal test conditions);  
where possible, the receiver volume control shall be adjusted to give at least 50 % of the rated output power (see clause 6.11) or, in the case of stepped volume controls, to the first step that provides an output power of at least 50 % of the rated output power. The obtained audio output level shall be noted;
- c) the unwanted signals from generators B and C shall then be switched on;
- d) their levels shall be maintained equal and shall be adjusted so that the unwanted signal causes:
  - a reduction of 3 dB in the output level of the wanted signal; or
  - a reduction to 14 dB of the SINAD ratio at the receiver output (with a psophometric filter), whether or not measured acoustically;whichever occurs first;
- e) the level of the unwanted signals shall be noted;
- f) for each configuration of the unwanted signals, the intermodulation response rejection shall be recorded as the lowest value noted in step e);
- g) the measurement shall be repeated with the unwanted signal generator B at the frequency 25 kHz below that of the wanted signal and the frequency of the unwanted signal generator C at the frequency 50 kHz below that of the wanted signal;  
the measurement shall also be repeated with the unwanted signal generator B at the frequency 50 kHz below that of the wanted signal and the frequency of the unwanted signal generator C at the frequency 100 kHz below that of the wanted signal;  
the measurement shall be repeated again with the unwanted signal generator B at the frequency 50 kHz above that of the wanted signal and the frequency of the unwanted signal generator C at the frequency 100 kHz above that of the wanted signal;
- h) the intermodulation response rejection of the equipment under test shall be expressed as the lowest of the values recorded in step f).

### 8.7.2.2 Method of measurement (data with continuous bit stream)

The measurement procedure shall be as follows:

- a) three signal generators, A, B and C, shall be connected to the receiver via a combining network (see clause 6.9);  
the wanted signal, provided by signal generator A, shall be at the nominal frequency of the receiver and shall be modulated by the test signal M2 (see clause 6.1.3);  
the first unwanted signal, provided by signal generator B, shall be unmodulated and adjusted to a frequency 25 kHz above the nominal frequency of the receiver;  
the second unwanted signal, provided by signal generator C, shall be modulated with test signal M3 (see clause 6.1.3) and adjusted to a frequency 50 kHz above the nominal frequency of the receiver;
- b) initially, signal generators B and C (unwanted signals) shall be switched off (maintaining the output impedance);  
the level of the wanted signal from generator A shall be adjusted to the level which is 3 dB above the relevant limit in clause 8.3.3, at the receiver input terminals;
- c) signal generators B and C shall then be switched on, and the level of the two unwanted signals shall be maintained equal and shall be adjusted until a bit error ratio of  $10^{-1}$  or worse is obtained;
- d) the test signal M2 shall be transmitted whilst observing the bit error ratio;
- e) the level of the unwanted signals shall be reduced in steps of 1 dB until a bit error ratio of  $10^{-2}$  or better is obtained. The level of the unwanted signals shall then be noted;
- f) for each configuration of the unwanted signals, the intermodulation response rejection shall be recorded as the lowest value noted in step e);
- g) the measurement shall be repeated with the unwanted signal generator B at the frequency 25 kHz below that of the wanted signal and the frequency of the unwanted signal generator C at the frequency 50 kHz below that of the wanted signal;  
the measurement shall also be repeated with the unwanted signal generator B at the frequency 50 kHz below that of the wanted signal and the frequency of the unwanted signal generator C at the frequency 100 kHz below that of the wanted signal;  
the measurement shall be repeated again with the unwanted signal generator B at the frequency 50 kHz above that of the wanted signal and the frequency of the unwanted signal generator C at the frequency 100 kHz above that of the wanted signal;
- h) the intermodulation response rejection of the equipment under test shall be expressed as the lowest of the values recorded in step f).

### 8.7.2.3 Method of measurement with messages

In the case where operation using a continuous bit stream is not possible, the following method of measurement shall be applied.

The measurement procedure shall be as follows:

- a) three signal generators, A, B and C, shall be connected to the receiver via a combining network (see clause 6.9);  
the wanted signal, provided by signal generator A, shall be at the nominal frequency of the receiver and shall have test signal M6 (see clause 6.1.3);  
the first unwanted signal, provided by signal generator B, shall be unmodulated and adjusted to a frequency 25 kHz above the nominal frequency of the receiver;  
the second unwanted signal, provided by signal generator C, shall be modulated with test signal M3 (see clause 6.1.3) and adjusted to a frequency 50 kHz above the nominal frequency of the receiver;

- b) initially, signal generator B (unwanted signal) shall be switched off (maintaining the output impedance);  
the level of the wanted signal from generator A shall be adjusted to the level which is 3 dB above the relevant limit or manufacturer's declaration in clause 8.3.3, at the receiver input terminals;
- c) signal generators B and C shall then be switched on; the levels of the two unwanted signals shall be maintained equal and shall be adjusted until a successful message ratio of less than 10 % is obtained;
- d) the test signal M6 (see clause 6.1.3) shall then be transmitted repeatedly whilst observing in each case whether or not a message is successfully received;  
the level of the unwanted signal shall be reduced by 2 dB for each occasion that a message is not successfully received;  
the procedure shall be continued until three consecutive messages are successfully received. The level of the input signal shall then be noted;
- e) the level of the unwanted signal shall be increased by 1 dB and the new value noted;  
the normal test signal (see clause 7.3) shall then be transmitted 20 times. In each case, if a message is not successfully received the level of the unwanted signal shall be reduced by 1 dB and the new value noted;  
if a message is successfully received, the level of the unwanted signals shall not be changed until three consecutive messages have been successfully received. In this case the unwanted signal shall be increased by 1 dB and the new value noted;  
no level of the unwanted signal shall be noted unless preceded by a change in level;  
the average of the values noted in steps d) and e) (which provides the level corresponding to the successful message ratio of 80 %) shall be noted;
- f) for each configuration of the unwanted signals, the intermodulation response rejection shall be recorded as the lowest value noted in step e);
- g) the measurement shall be repeated with the unwanted signal generator B at the frequency 25 kHz below that of the wanted signal and the frequency of the unwanted signal generator C at the frequency 50 kHz below that of the wanted signal;  
the measurement shall also be repeated with the unwanted signal generator B at the frequency 50 kHz below that of the wanted signal and the frequency of the unwanted signal generator C at the frequency 100 kHz below that of the wanted signal;  
the measurement shall be repeated again with the unwanted signal generator B at the frequency 50 kHz above that of the wanted signal and the frequency of the unwanted signal generator C at the frequency 100 kHz above that of the wanted signal;
- h) the intermodulation response rejection of the equipment under test shall be expressed as the lowest of the values recorded in step f).

### 8.7.3 Limit

The intermodulation response rejection of the equipment shall be such that under the specified test conditions, the given degradation shall not be exceeded for levels of the unwanted signal up to 76 dB $\mu$ V for base stations and 71 dB $\mu$ V for mobile and handportable stations.

## 8.8 Blocking or desensitization

For digital equipment that supports adaptive rates, testing is only required at the maximum bit rate that the manufacturer declares is compliant to the present document.

### 8.8.1 Definition

Blocking is a measure of the capability of the receiver to receive a wanted modulated signal without exceeding a given degradation due to the presence of an unwanted input signal at any frequencies other than those of the spurious responses or the adjacent channels.

### 8.8.2 Method of measurement

#### 8.8.2.1 Method of measurement (analogue)

The measurement procedure shall be as follows:

- a) two signal generators, A and B, shall be connected to the receiver via a combining network (see clause 6.9); the wanted signal, provided by signal generator A, shall be at the nominal frequency of the receiver and shall have receiver analogue test modulation, (see clause 6.1.2);

the unwanted signal, provided by signal generator B, shall be unmodulated and shall be at a frequency from 1 MHz to 10 MHz away from the nominal frequency of the receiver;

for practical reasons the measurements shall be carried out at frequencies of the unwanted signal at approximately  $\pm 1$  MHz,  $\pm 2$  MHz,  $\pm 5$  MHz and  $\pm 10$  MHz, avoiding those frequencies at which spurious responses occur (see clause 8.6);

- b) initially, signal generator B (unwanted signal) shall be switched off (maintaining the output impedance);

the level of the wanted signal from generator A shall be adjusted to the level which is the value of the limit for the maximum usable sensitivity (i.e. 6 dB above 1  $\mu$ V emf under normal test conditions);

where possible, the receiver volume control shall be adjusted to give at least 50 % of the rated output power (see clause 6.11) or, in the case of stepped volume controls, to the first step that provides an output power of at least 50 % of the rated output power. The obtained audio output level shall be noted;

- c) the unwanted signal from generator B shall then be switched on;

- d) the level of generator B shall be adjusted so that the unwanted signal causes:

- a reduction of 3 dB in the output level of the wanted signal; or
- a reduction to 14 dB of the SINAD ratio at the receiver output (with a psophometric filter), whether or not measured acoustically;

whichever occurs first;

- e) the level of the unwanted signal shall be noted;

- f) for each frequency, the blocking or desensitization shall be expressed as the level in dB $\mu$ V of the unwanted signal at the receiver for each frequency; this value shall be recorded;

- g) the measurement shall be repeated for all the frequencies defined in step a);

- h) the blocking or desensitization of the equipment under test shall be expressed as the lowest of the values recorded in step f).

### 8.8.2.2 Method of measurement (data with continuous bit stream)

The measurement procedure shall be as follows:

- a) two signal generators, A and B, shall be connected to the receiver via a combining network (see clause 6.9);  
the wanted signal, provided by signal generator A, shall be at the nominal frequency of the receiver and shall be modulated by the test signal M2 (see clause 6.1.3);  
the unwanted signal, provided by signal generator B, shall be unmodulated and shall be at a frequency from 1 MHz to 10 MHz away from the nominal frequency of the receiver;  
for practical reasons the measurements shall be carried out at frequencies of the unwanted signal at approximately  $\pm 1$  MHz,  $\pm 2$  MHz,  $\pm 5$  MHz and  $\pm 10$  MHz, avoiding those frequencies at which spurious responses could occur (see clause 8.6);
- b) initially, signal generator B (unwanted signal) shall be switched off (maintaining the output impedance);  
the level of the wanted signal from generator A shall be adjusted to the level which is 3 dB above the relevant limit in clause 8.3.3, at the receiver input terminals;
- c) signal generator B shall then be switched on, and the level of the unwanted signal adjusted until a bit error ratio of  $10^{-1}$  or worse is obtained;
- d) the test signal M2 shall be transmitted whilst observing the bit error ratio;
- e) the level of the unwanted signal shall be reduced in steps of 1 dB until a bit error ratio of  $10^{-2}$  or better is obtained. The level of the unwanted signal shall then be noted;
- f) for each frequency, the blocking or desensitization shall be expressed as the level in dB $\mu$ V of the unwanted signal at the receiver for each frequency; this value shall be recorded;
- g) the measurement shall be repeated for all the frequencies defined in step a);
- h) the blocking or desensitization of the equipment under test shall be expressed as the lowest of the values recorded in step f).

### 8.8.2.3 Method of measurement with messages

In the case where operation using a continuous bit stream is not possible, the following method of measurement shall be applied.

The measurement procedure shall be as follows:

- a) two signal generators, A and B, shall be connected to the receiver via a combining network (see clause 6.9);  
the wanted signal, provided by signal generator A, shall be at the nominal frequency of the receiver and shall have test signal M6 (see clause 6.1.3);  
the unwanted signal, provided by signal generator B, shall be unmodulated and shall be at a frequency from 1 MHz to 10 MHz away from the nominal frequency of the receiver;  
for practical reasons the measurements shall be carried out at frequencies of the unwanted signal at approximately  $\pm 1$  MHz,  $\pm 2$  MHz,  $\pm 5$  MHz and  $\pm 10$  MHz, avoiding those frequencies at which spurious responses could occur (see clause 8.6);
- b) initially, signal generator B (unwanted signal) shall be switched off (maintaining the output impedance);  
the level of the wanted signal from generator A shall be adjusted to the level which is 3 dB above the relevant limit or manufacturer's declaration in clause 8.3.3., at the receiver input terminals;
- c) signal generator B shall then be switched on, and the level of the unwanted signal adjusted until a successful message ratio of less than 10 % is obtained;

- d) the test signal M6 (see clause 6.1.3) shall then be transmitted repeatedly whilst observing in each case whether or not a message is successfully received;

the level of the unwanted signal shall be reduced by 2 dB for each occasion that a message is not successfully received;

the procedure shall be continued until three consecutive messages are successfully received. The level of the input signal shall then be noted;

- e) the level of the unwanted signal shall be increased by 1 dB and the new value noted;

the normal test signal (see clause 7.3) shall then be transmitted 20 times. In each case, if a message is not successfully received the level of the unwanted signal shall be reduced by 1 dB and the new value noted;

if a message is successfully received, the level of the unwanted signals shall not be changed until three consecutive messages have been successfully received. In this case the unwanted signal shall be increased by 1 dB and the new value noted;

no level of the unwanted signal shall be noted unless preceded by a change in level;

the average of the values noted in steps d) and e) (which provides the level corresponding to the successful message ratio of 80 %) shall be noted;

for each frequency, the blocking or desensitization shall be expressed as the level in dB $\mu$ V of the unwanted signal at the receiver for each frequency; this value shall be recorded;

- f) the measurement shall be repeated for all the frequencies defined in step a);
- g) the blocking or desensitization of the equipment under test shall be expressed as the lowest of the values recorded in step f).

### 8.8.3 Limit

The blocking level, for any frequency within the specified ranges, shall not be less than 90.0 dB $\mu$ V except at frequencies on which spurious responses are found, clause 8.6.

## 8.9 Spurious radiations

For digital equipment that supports adaptive rates, testing is only required at the maximum bit rate that the manufacturer declares is compliant to the present document.

### 8.9.1 Definition

Spurious radiations from the receiver are components at any frequency, radiated by the equipment and antenna.

The level of spurious radiations shall be measured by either:

- a) their power level in a specified load (conducted spurious emission); and
- b) their effective radiated power when radiated by the cabinet and structure of the equipment (cabinet radiation); or
- c) their effective radiated power when radiated by the cabinet and the integral antenna, in the case of handportable equipment fitted with such an antenna and no external RF connector.

## 8.9.2 Methods of measurement

### 8.9.2.1 Method of measuring the power level in a specified load (clause 8.9.1a))

This method applies only to equipment with an external 50  $\Omega$  antenna connector.

Spurious radiations shall be measured as the power level of any discrete signal at the input terminals of the receiver. The receiver input terminals are connected to a spectrum analyser or selective voltmeter having an input impedance of 50  $\Omega$  and the receiver switched on.

If the detecting device is not calibrated in terms of power input, the level of any detected components shall be determined by a substitution method using a signal generator.

The measurements shall extend over the frequency range 9 kHz to 4 GHz for equipment operating on frequencies not exceeding 470 MHz or over the frequency range 9 kHz to 12,75 GHz for equipment operating on frequencies above 470 MHz.

At each frequency at which a spurious component is detected, the power level shall be recorded as the spurious level delivered into the specified load.

### 8.9.2.2 Method of measuring the effective radiated power (clause 8.9.1b))

This method applies only to equipment having an external antenna connector.

The measurement procedure shall be as follows:

- a) a test site which fulfils the requirements for the specified frequency range of this measurement shall be used (see annex A);  
  
the equipment shall be placed at the specified height on a non-conducting support and in the position closest to normal use as declared by the manufacturer;
- b) the receiver antenna connector shall be connected to an artificial antenna (see clause 6.2):
  - the test antenna shall be orientated for vertical polarization and the length of the test antenna shall be chosen to correspond to the instant frequency of the measuring receiver;
  - the output of the test antenna shall be connected to a measuring receiver;
- c) radiation of any spurious components shall be detected by the test antenna and receiver, over the frequency range 30 MHz to 4 GHz;
- d) at each frequency at which a component is detected the test antenna shall be raised and lowered through the specified range of height until a maximum signal level is detected by the measuring receiver;  
  
when a test site according to clause A.1.1 is used, there is no need to vary the height of the antenna;
- e) the receiver shall then be rotated through 360° in the horizontal plane until the maximum signal level detected by the measuring receiver;  
  
the maximum signal level detected by the measuring receiver shall be noted;
- f) the receiver shall be replaced by a substitution antenna as defined in clause A.1.5;  
  
the substitution antenna shall be orientated for vertical polarization and the length of the substitution antenna shall be adjusted to correspond to the frequency of the spurious component detected;
- g) the substitution antenna shall be connected to a calibrated signal generator;  
  
the frequency of the calibrated signal generator shall be set to the frequency of the spurious component detected;
- h) the input attenuator setting of the measuring receiver shall be adjusted in order to increase the sensitivity of the measuring receiver if necessary;



- i) the test antenna shall be raised and lowered through the specified range of height to ensure that the maximum signal is received;

the input signal to the substitution antenna shall be adjusted to the level that produces a level detected by the measuring receiver, that is equal to the level noted while the spurious component was measured, corrected for the change of input attenuator setting of the measuring receiver;

the input level of the substitution antenna shall be recorded as a power level, corrected for the change of input attenuator setting of the measuring receiver;

- j) the measurement shall be repeated with the test antenna and the substitution antenna orientated for horizontal polarization;
- k) the measure of the effective radiated power of the spurious components is the larger of the two power levels recorded for each spurious component at the input to the substitution antenna, corrected for the gain of the antenna if necessary.

### 8.9.2.3 Method of measuring the effective radiated power (clause 8.9.1.c)

This method applies only to equipment without an external antenna connector.

The method of measurement shall be performed according to clause 8.9.2.2, except that the receiver input shall be connected to the integral antenna and not to an artificial antenna.

## 8.9.3 Limits

The power of any spurious radiations shall not exceed the values given in tables 7 and 8.

**Table 7: Conducted components**

Frequency range	9 kHz to 1 GHz	Above 1 GHz to 4 GHz, or above 1 GHz to 12,75 GHz, (see clause 8.9.2)
Limit	2,0 nW (-57,0 dBm)	20,0 nW (-47,0 dBm)

**Table 8: Radiated components**

Frequency range	30 MHz to 1 GHz	Above 1 GHz to 4 GHz
Limit	2,0 nW (-57,0 dBm)	20,0 nW (-47,0 dBm)

In the case of radiated measurements for handportable stations the following conditions apply:

- internal integral antenna: the normal antenna shall be connected;
- external antenna socket: an artificial load shall be connected to the socket for the test.

## 8.10 Co-channel rejection

For digital equipment that supports adaptive rates, testing is only required at two bit rates, the minimum bit rate supported by the equipment and the maximum bit rate that the manufacturer declares is compliant to the present document.

### 8.10.1 Definition

The co-channel rejection ratio is a measure of the capability of the receiver to receive a wanted modulated signal without exceeding a given degradation due to the presence of an unwanted modulated signal, both signals being at the nominal frequency of the receiver.

## 8.10.2 Methods of measurement

### 8.10.2.1 Method of measurement (analogue)

The measurement procedure shall be as follows:

- a) two signal generators, A and B, shall be connected to the receiver via a combining network (see clause 6.9);  
 the wanted signal, provided by signal generator A, shall be at the nominal frequency of the receiver and shall have receiver analogue test modulation, (see clause 6.1.2);  
 the unwanted signal, provided by signal generator B, shall be modulated test signal M4 (see clause 6.1.3) and shall also be at the nominal frequency of the receiver;
- b) initially, signal generator B (unwanted signal) shall be switched off (maintaining the output impedance);  
 the level of the wanted signal from generator A shall be adjusted to a level which is 20 dB above the value of the limit for the maximum usable sensitivity (i.e. 26 dB above 1  $\mu$ V emf under normal test conditions);  
 where possible, the receiver volume control shall be adjusted to give at least 50 % of the rated output power (clause 6.11) or, in the case of stepped volume controls, to the first step that provides an output power of at least 50 % of the rated output power. The obtained audio output level shall be noted;
- c) the unwanted signal from generator B shall then be switched on;
- d) the level of generator B shall be adjusted so that the unwanted signal causes:
  - a reduction of 3 dB in the output level of the wanted signal; or
  - a reduction to 14 dB of the SINAD ratio at the receiver output (with a psophometric filter), whether or not measured acoustically;
 whichever occurs first;
- e) the level of the unwanted signal shall be noted;
- f) for each frequency of the unwanted signal, the co-channel rejection ratio shall be expressed as the ratio, in dB, of the level of the unwanted signal to the level of the wanted signal, at the receiver input. This ratio shall be recorded;
- g) the measurement shall be repeated for displacements of the unwanted signal of  $\pm 12$  % of the CSP;
- h) the co-channel rejection ratio of the equipment under test shall be expressed as the lowest of the three values expressed in dB, calculated in step f).

The value of the co-channel rejection ratio, expressed in dB, is generally negative (therefore, for example, -12 dB is lower than -8 dB).

### 8.10.2.2 Method of measurement (data with continuous bit stream)

The measurement procedure shall be as follows:

- a) two signal generators, A and B, shall be connected to the receiver via a combining network (clause 6.9);  
 the wanted signal, provided by signal generator A, shall be at the nominal frequency of the receiver and shall be modulated by the test signal M2 (clause 6.1.3);  
 the unwanted signal, provided by signal generator B, shall be modulated test signal M4 (clause 6.1.3) and shall also be at the nominal frequency of the receiver;
- b) initially, signal generator B (unwanted signal) shall be switched off (maintaining the output impedance);  
 the level of the wanted signal from generator A shall be adjusted to the level which is 20 dB above the relevant limit in clause 8.3.3, at the receiver input terminals;

- c) signal generator B shall then be switched on, and the level of the unwanted signal adjusted until a bit error ratio of  $10^{-1}$  or worse is obtained;
- d) the test signal M2 shall be transmitted whilst observing the bit error ratio;
- e) the level of the unwanted signal shall be reduced in steps of 1 dB until a bit error ratio of  $10^{-2}$  or better is obtained. The level of the unwanted signal shall then be noted;
- f) for each frequency of the unwanted signal, the co-channel rejection ratio shall be expressed as the ratio, in dB, of the level of the unwanted signal to the level of the wanted signal, at the receiver input. This ratio shall be recorded;
- g) the measurement shall be repeated for displacements of the unwanted signal of  $\pm 12\%$  of the CSP;
- h) the co-channel rejection ratio of the equipment under test shall be expressed as the lowest of the three values expressed in dB, calculated in step f).

The value of the co-channel rejection ratio, expressed in dB, is generally negative (therefore, for example, -12 dB is lower than -8 dB).

### 8.10.2.3 Method of measurement with messages

In the case where operation using a continuous bit stream is not possible, the following method of measurement shall be applied.

The measurement procedure shall be as follows:

- a) two signal generators, A and B, shall be connected to the receiver via a combining network (see clause 6.9);  
the wanted signal, provided by signal generator A, shall be at the nominal frequency of the receiver and shall have test signal M6 (see clause 6.1.3);  
the unwanted signal, provided by signal generator B, shall be modulated test signal M4 (see clause 6.1.3) and shall also be at the nominal frequency of the receiver;
- b) initially, signal generator B (unwanted signal) shall be switched off (maintaining the output impedance);  
the level of the wanted signal from generator A shall be adjusted to the level which is 20 dB above the relevant limit or manufacturer's declaration in clause 8.3.3, at the receiver input terminals;
- c) signal generator B shall then be switched on, and the level of the unwanted signal adjusted until a successful message ratio of less than 10 % is obtained;
- d) the test signal M6 (see clause 6.1.3) shall then be transmitted repeatedly whilst observing in each case whether or not a message is successfully received;  
the level of the unwanted signal shall be reduced by 2 dB for each occasion that a message is not successfully received;  
the procedure shall be continued until three consecutive messages are successfully received. The level of the input signal shall then be noted;
- e) the level of the unwanted signal shall be increased by 1 dB and the new value noted;  
the normal test signal (see clause 7.3) shall then be transmitted 20 times. In each case, if a message is not successfully received the level of the unwanted signal shall be reduced by 1 dB and the new value noted;  
if a message is successfully received, the level of the unwanted signals shall not be changed until three consecutive messages have been successfully received. In this case the unwanted signal shall be increased by 1 dB and the new value noted;  
no level of the unwanted signal shall be noted unless preceded by a change in level;  
the average of the values noted in steps d) and e) (which provides the level corresponding to the successful message ratio of 80 %) shall be noted;

- f) for each frequency of the unwanted signal, the co-channel rejection ratio shall be expressed as the ratio, in dB, of the level of the unwanted signal to the level of the wanted signal, at the receiver input. This ratio shall be recorded;
- g) the measurement shall be repeated for displacements of the unwanted signal of  $\pm 12\%$  of the CSP;
- h) the co-channel rejection ratio of the equipment under test shall be expressed as the lowest of the three values expressed in dB, calculated in step f).

The value of the co-channel rejection ratio, expressed in dB, is generally negative (therefore, for example, -12 dB is lower than -8 dB).

### 8.10.3 Limits

The value of co-channel rejection ratio shall be:

- greater than -15 dB for analogue tests;
- greater than -12 dB for equipment operating with data rates of up to 2 400 bits per second;
- greater than -15 dB for equipment operating with data rates between 2 401 bits per second and 4 800 bits per second;
- greater than -18 dB for equipment operating with data rates between 4 801 bits per second and 9 600 bits per second;
- greater than -24 dB for equipment operating with data rates greater than 9 600 bits per second.

---

## 9 Duplex operation

If the equipment is designed for duplex operation, when submitted for type testing it shall be fitted with a duplex filter and the following additional measurements shall be carried out to ensure satisfactory duplex operation.

Duplex measurements shall be carried out on a single pair of frequencies only, as specified by the manufacturer/applicant in consultation with the appropriate administration.

Duplex equipment having integral antenna may be tested using the internal or temporary antenna connector.

### 9.1 Receiver desensitization (with simultaneous transmission and reception)

#### 9.1.1 Definition

The desensitization is the degradation of the sensitivity of the receiver resulting from some power from the transmitter coupling into the receiver. The desensitization is expressed as the difference in dB between the maximum usable sensitivity levels with and without simultaneous transmissions.

## 9.1.2 Methods of measurement

### 9.1.2.1 Desensitization measured with analogue modulation

#### 9.1.2.1.1 Method of measurement when the equipment has a duplex filter

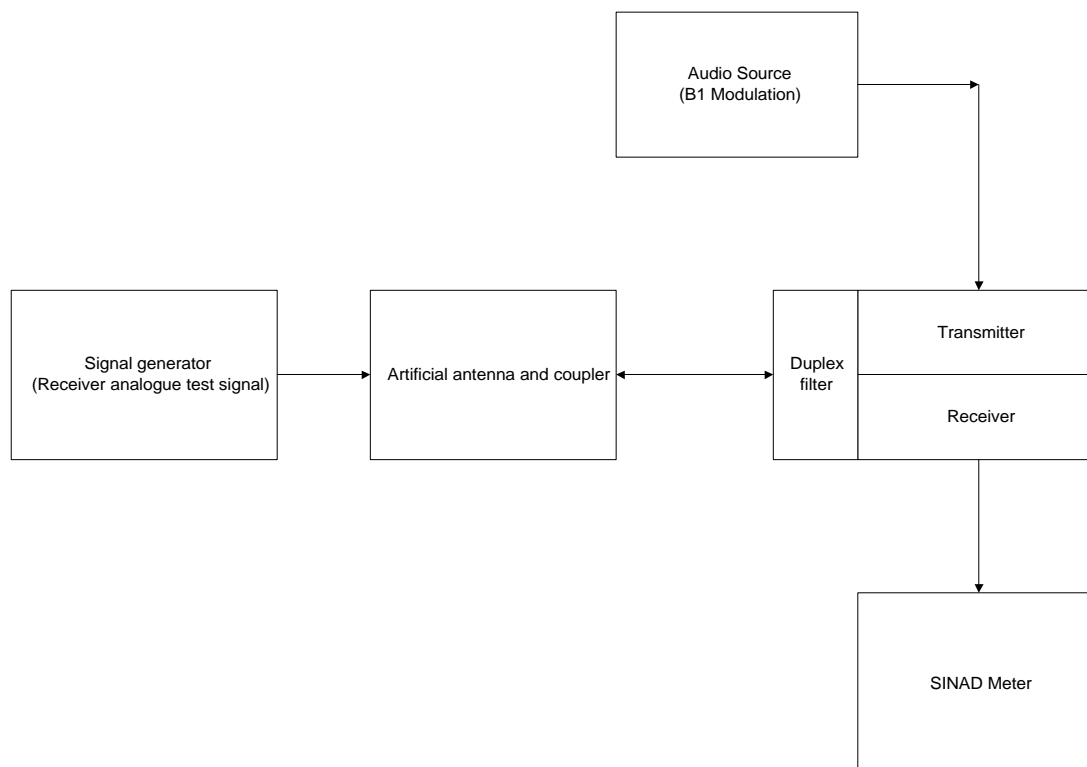

**Figure 7: Measurement arrangement**

The measurement procedure shall be as follows:

- a) the antenna connector of the equipment shall be connected to a power attenuator giving sufficient protection to the devices connected to the power attenuator output;
 

a signal generator modulated by the receiver analogue test signal (see clause 6.1.2), shall be connected to the power attenuator so that it does not affect the impedance matching and does not generate intermodulation products which could impair the results of the measurement;
- b) the transmitter shall be brought into operation at the output power as defined in clause 7.1, modulated by the test signal B1 (see clause 6.1.1);
 

the receiver sensitivity (analogue, conducted) shall then be measured in accordance with clause 8.1.2;
- c) the output level of the signal generator shall be noted as C in dB relative to an emf of 1  $\mu$ V;
- d) the transmitter shall then be switched off and the receiver sensitivity (analogue, conducted, see clause 8.1.2) is measured again;
- e) the output level of the signal generator shall be noted as D in dB relative to an emf of 1  $\mu$ V;
- f) the desensitization is the difference between the values of C and D in dB.

## 9.1.2.1.2 Method of measurement when the equipment has to operate with two antennas

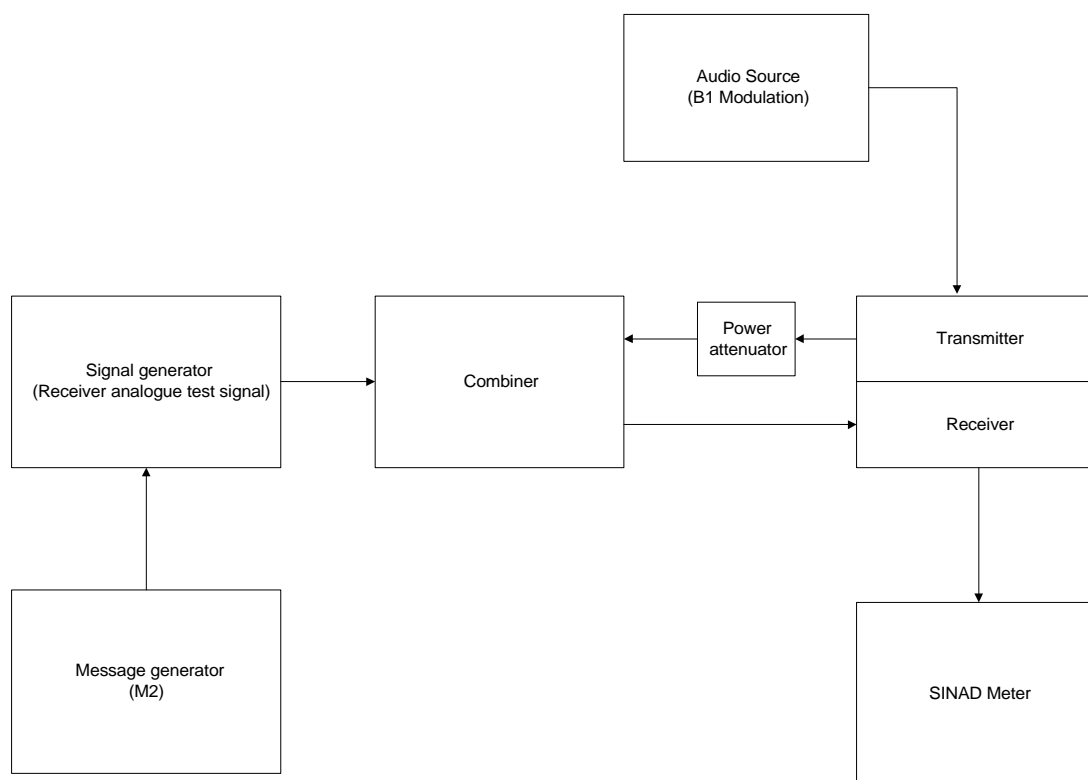

**Figure 8: Measurement arrangement**

The measurement procedure shall be as follows:

- a) the transmitter shall be connected to a power attenuator the output of which is fed to the receiver via a combiner;
 

the total attenuation of the power attenuator and the combiner shall be 30 dB, which is intended to simulate a corresponding antenna isolation;

if an external filter at the transmitter output or an external filter at the receiver input or both are part of the normal operation arrangement, this or these filters shall be included in the measurement arrangement accordingly;

a signal generator modulated by the receiver analogue test signal (see clause 6.1.2) shall be connected to the combiner in such a way as not to affect the impedance matching and does not generate intermodulation products which could impair the results of the measurement;
- b) the transmitter shall be brought into operation with an output power as defined in clause 7.1, modulated by the test signal B1 (see clause 6.1.1);
 

the receiver sensitivity (analogue, conducted) shall then be measured in accordance with clause 8.1.2;
- c) the output level of the signal generator shall be noted as C in dB relative to an emf of 1  $\mu$ V;
- d) the transmitter shall then be switched off and the receiver sensitivity (analogue, conducted) measured again;
- e) the output level of the signal generator shall be noted as D in dB relative to an emf of 1  $\mu$ V;
- f) the desensitization is the difference between the values of C and D in dB.

## 9.1.2.2 Desensitization measured with continuous bit streams

### 9.1.2.2.1 Method of measurement when the equipment has a duplex filter

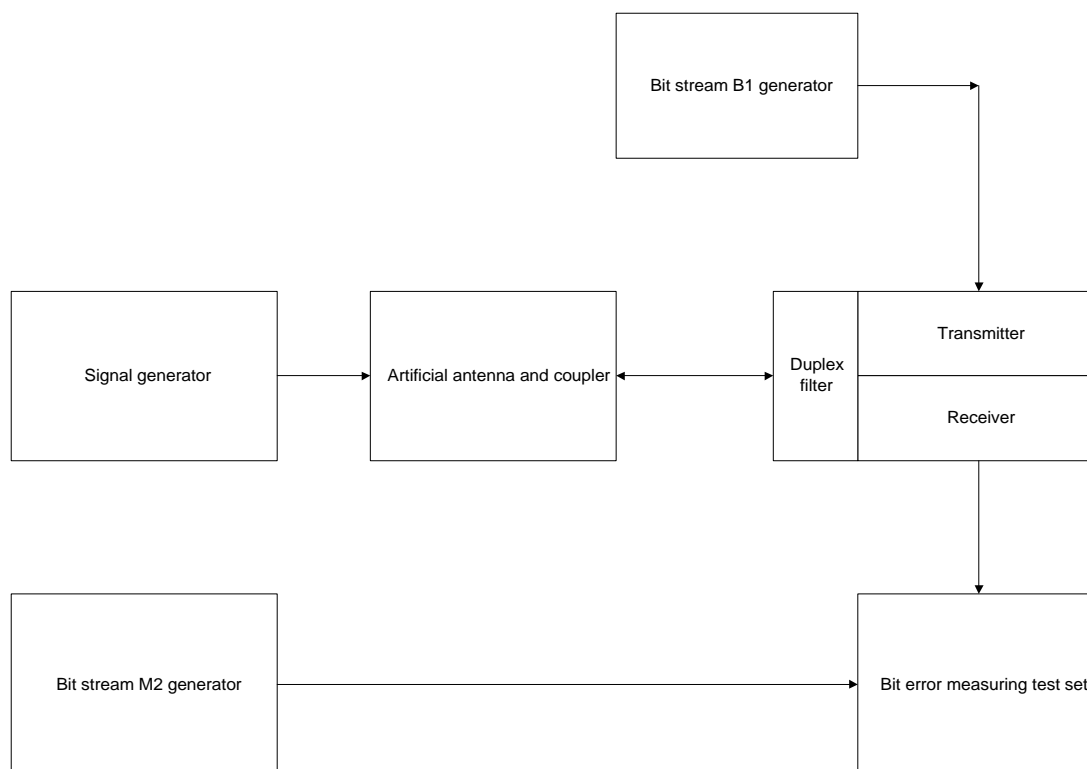

**Figure 9: Measurement arrangement**

The measurement procedure shall be as follows:

- a) the antenna connector of the equipment shall be connected to a power attenuator giving sufficient protection to the devices connected to the power attenuator output;

a signal generator modulated by the test signal M2 (see clause 6.1.3), shall be connected to the power attenuator so that it does not affect the impedance matching and does not generate intermodulation products which could impair the results of the measurement;

- b) the transmitter shall be brought into operation at the output power as defined in clauses 7.1, modulated by the test signal M5 (see clause 6.1.1);

the pseudo-random bit sequence used in signal M5 shall be uncorrelated with the one used in test signal M2 in step a);

the receiver sensitivity (data, conducted) shall then be measured in accordance with clause 8.3.2.1;

- c) the output level of the signal generator shall be noted as C in dB relative to an emf of 1  $\mu$ V;
- d) the transmitter shall then be switched off and the receiver sensitivity (data, conducted, clause 8.3.2.1) is measured again;
- e) the output level of the signal generator shall be noted as D in dB relative to an emf of 1  $\mu$ V;
- f) the desensitization is the difference between the values of C and D in dB.

## 9.1.2.2.2 Method of measurement when the equipment has to operate with two antennas

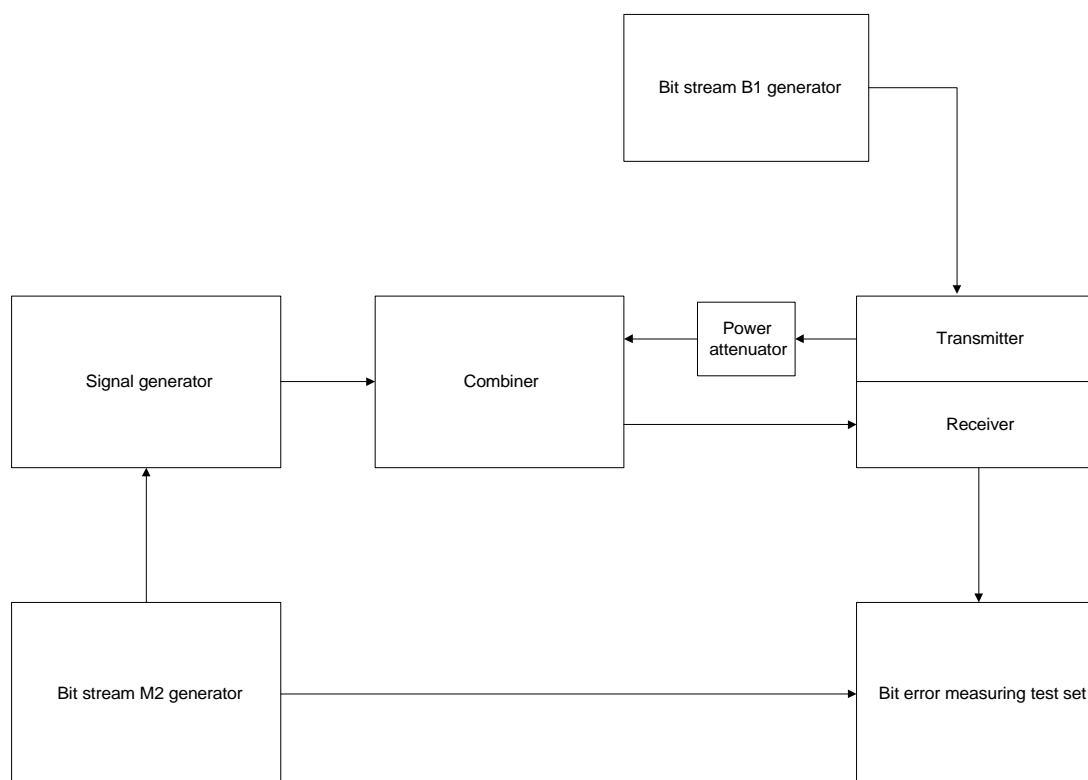

**Figure 10: Measurement arrangement**

The measurement procedure shall be as follows:

- a) the transmitter shall be connected to a power attenuator the output of which is fed to the receiver via a combiner;
 

the total attenuation of the power attenuator and the combiner shall be 30 dB, which is intended to simulate a corresponding antenna isolation;

if an external filter at the transmitter output or an external filter at the receiver input or both are part of the normal operation arrangement, this or these filters shall be included in the measurement arrangement accordingly;

a signal generator modulated by the test signal M2 (see clause 6.1.3) shall be connected to the combiner in such a way as not to affect the impedance matching and does not generate intermodulation products which could impair the results of the measurement;
- b) the transmitter shall be brought into operation with an output power as defined in clause 7.1, modulated by the test signal M5 (see clause 6.1.1);
 

the pseudo-random bit sequence used in signal M5 shall be uncorrelated with the one used in test signal M2 in step a);

the receiver sensitivity (data, conducted) shall then be measured in accordance with clause 8.3.2.1;
- c) the output level of the signal generator shall be noted as C in dB relative to an emf of 1  $\mu$ V;
- d) the transmitter shall then be switched off and the receiver sensitivity (data, conducted) measured again;
- e) the output level of the signal generator shall be noted as D in dB relative to an emf of 1  $\mu$ V;
- f) the desensitization is the difference between the values of C and D in dB.



### 9.1.2.3 Desensitization measured with messages

#### 9.1.2.3.1 Method of measurement when the equipment has a duplex filter

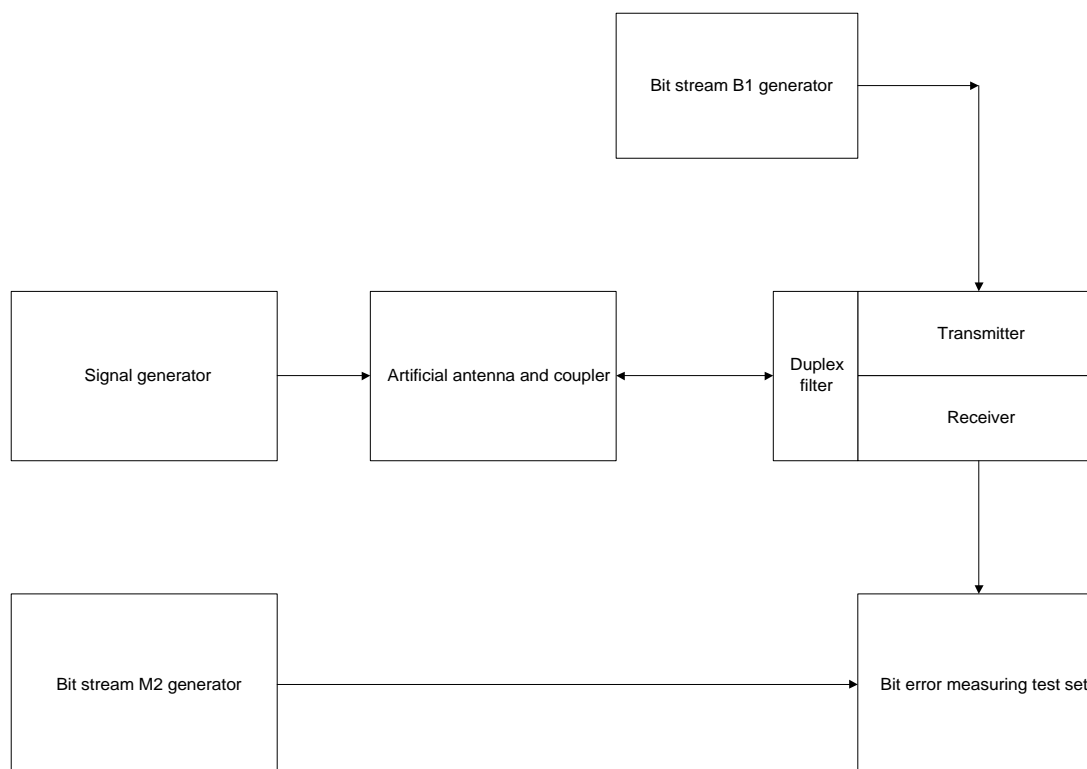

**Figure 11: Measurement arrangement**

The measurement procedure shall be as follows:

- a) the antenna connector of the equipment shall be connected to a power attenuator giving sufficient protection to the devices connected to the power attenuator output;
 

a signal generator having test modulation M6 (see clauses 6.1.3 and 6.4) shall be connected to the power attenuator so that it does not affect the impedance matching and does not generate intermodulation products which could impair the results of the measurement;
- b) the transmitter shall be brought into operation with an output power as defined in clause 7.1, and shall be modulated by test signal M7, using a message different from the message used in step a);
 

the receiver sensitivity (messages, conducted) shall then be measured in accordance with clause 8.3.2.2;
- c) the output level of the signal generator shall be noted as C in dB relative to an emf of 1  $\mu$ V;
- d) the transmitter shall then be switched off and the receiver sensitivity (messages, conducted) measured again;
- e) the output level of the signal generator shall be noted as D in dB relative to an emf of 1  $\mu$ V;
- f) the desensitization is the difference between the values of C and D in dB.

## 9.1.2.3.2 Method of measurement when the equipment has to operate with two antennas

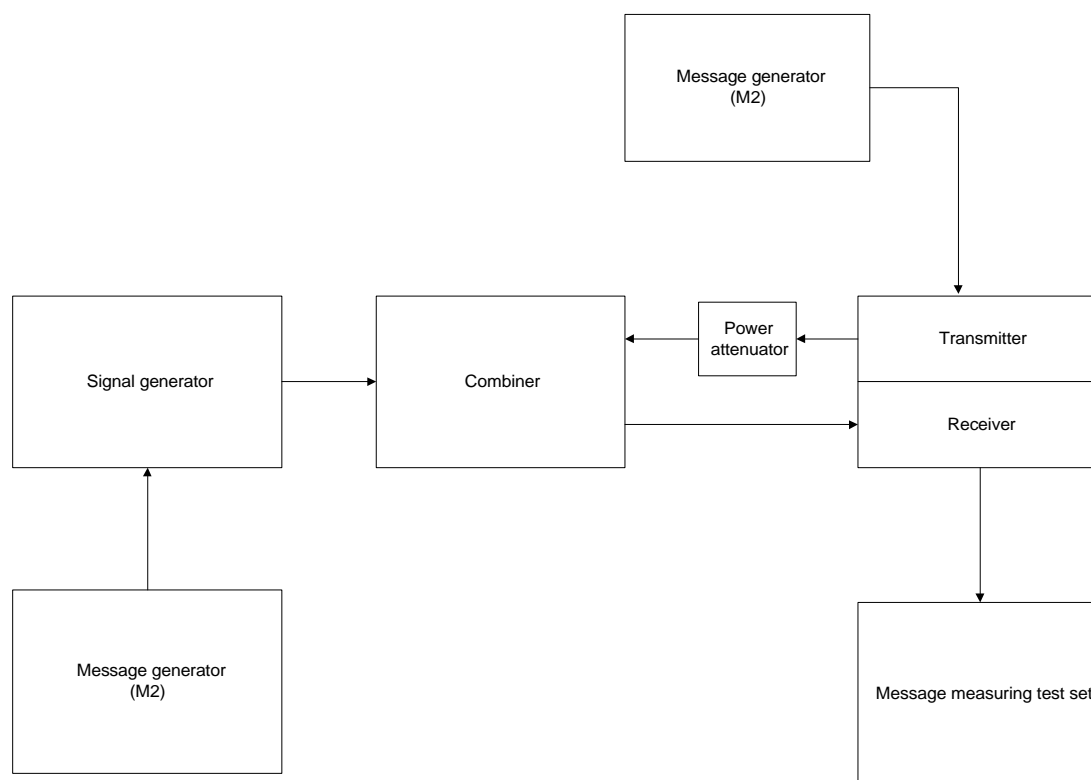

**Figure 12: Measurement arrangement**

The measurement procedure shall be as follows:

- a) the transmitter shall be connected to a power attenuator the output of which is fed to the receiver via a combiner;
 

the total attenuation of the power attenuator and the combiner shall be 30 dB, which is intended to simulate a corresponding antenna isolation;

if an external filter at the transmitter output or an external filter at the receiver input or both are part of the normal operation arrangement, this or these filters shall be included in the measurement arrangement accordingly;

a signal generator having test modulation M6 (see clauses 6.1.3 and 6.4) shall be connected to the combiner so that it does not affect the impedance matching and does not generate intermodulation products which could impair the results of the measurement;
- b) the transmitter shall be brought into operation with an output power as defined in clause 7.1, and shall be modulated by test signal M7, using a message different from the message used in step a);
 

the receiver sensitivity (messages, conducted) shall then be measured in accordance with clause 8.3.2.2;
- c) the output level of the signal generator shall be noted as C in dB relative to an emf of 1  $\mu$ V;
- d) the transmitter shall then be switched off and the receiver sensitivity (messages, conducted) measured again;
- e) the output level of the signal generator shall be noted as D in dB relative to an emf of 1  $\mu$ V;
- f) the desensitization is the difference between the values of C and D in dB.

### 9.1.3 Limits

The desensitization shall not exceed 3,0 dB.

The limit of maximum usable sensitivity measured in clauses 8.1.2 and 8.1.3 under normal test conditions shall exceed the specified limits in clauses 8.1.3 and 8.3.3 by an amount not less than the measured desensitization in the relevant clause 9.1.2.

## 9.2 Receiver spurious response rejection (with simultaneous transmission and reception)

### 9.2.1 Definition

The spurious response rejection, under duplex operation, is a measure of the capability of the receiver to achieve a specific spurious response rejection ratio when receiving a wanted modulated signal in the presence of:

- a) an unwanted signal at any other frequency, at which a response may be obtained; and
- b) the signal of the transmitter operating at duplex frequency distance, at the maximum output power and attenuated by the duplex filter and/or by the decoupling between the antennas.

### 9.2.2 Method of measurement

The receiver spurious response rejection under duplex operation shall be measured as specified in clause 8.6 with the measurement arrangements as shown in figures 13 to 18. The transmitter shall be operated at the maximum output power as defined in clause 7.1.

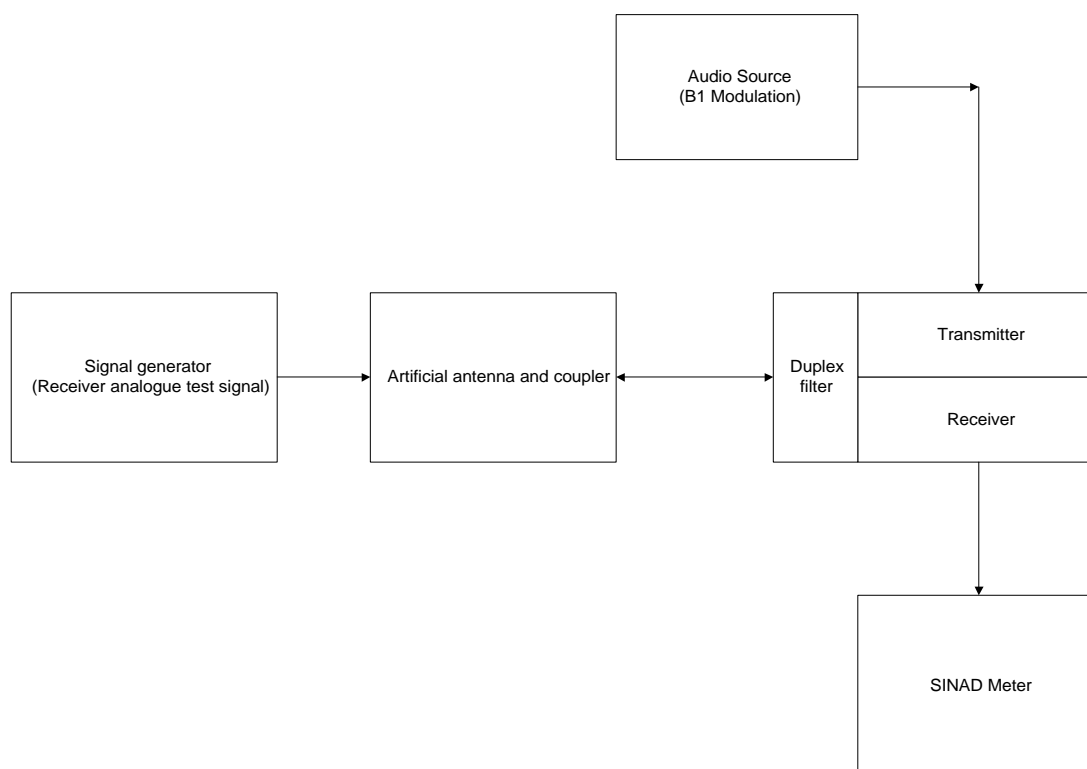

**Figure 13: Measurement arrangement for analogue equipment with a duplex filter**

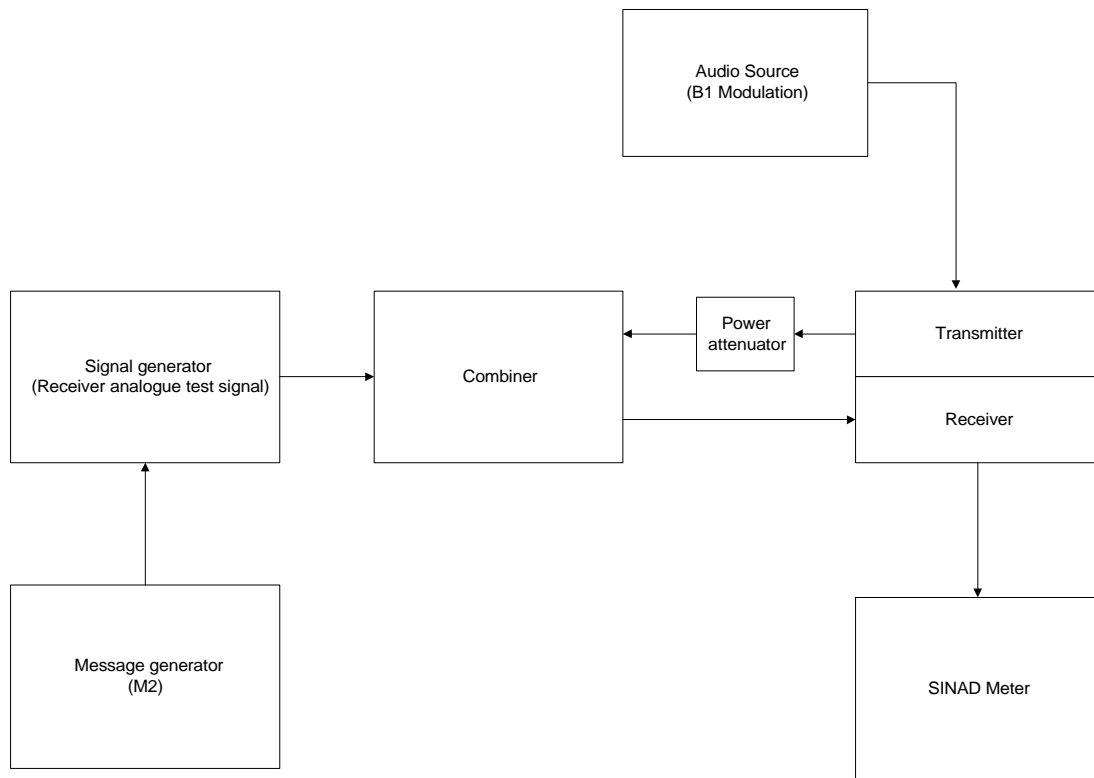

**Figure 14: Measurement arrangement for analogue equipment with two antennas**

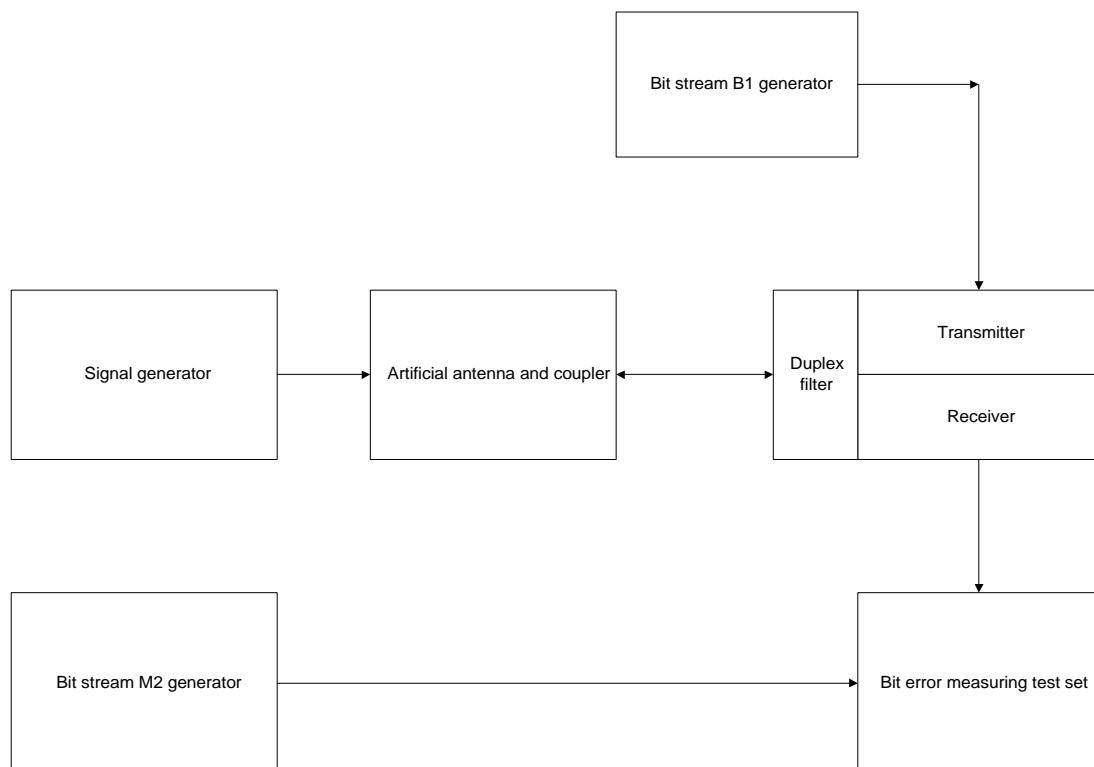

**Figure 15: Measurement arrangement for digital equipment (continuous bit streams) having a duplex filter**

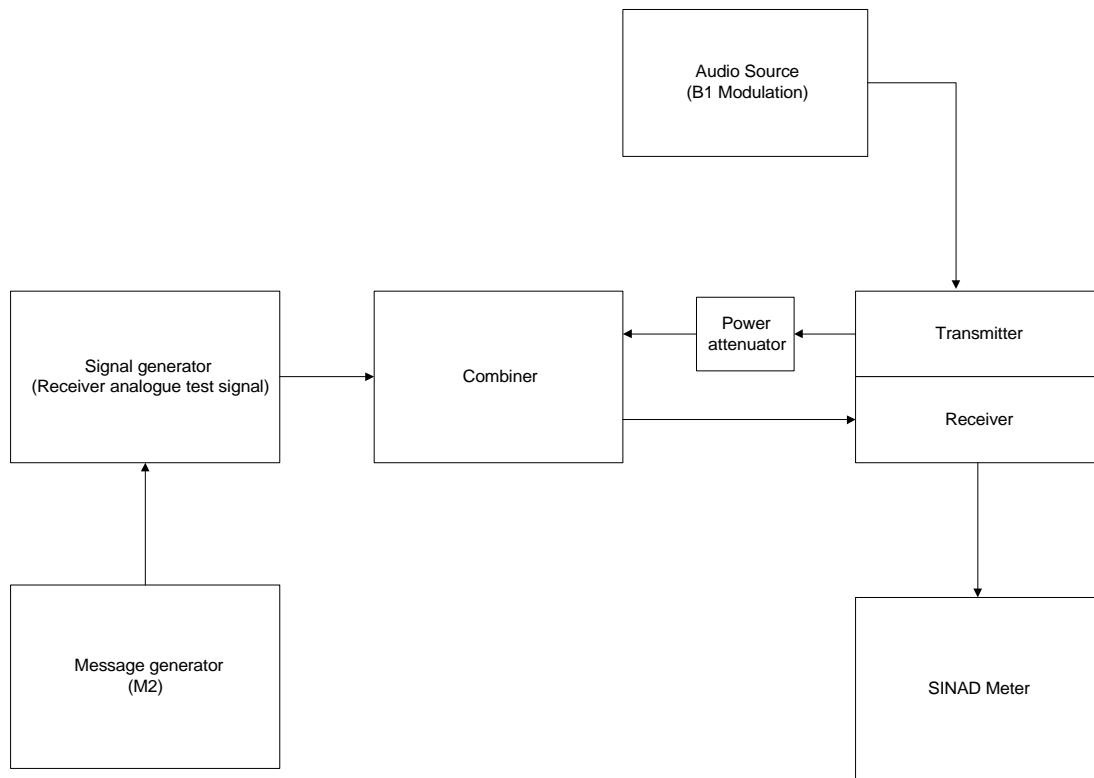

**Figure 16: Measurement arrangement for digital equipment (continuous bit streams) having two antennas**

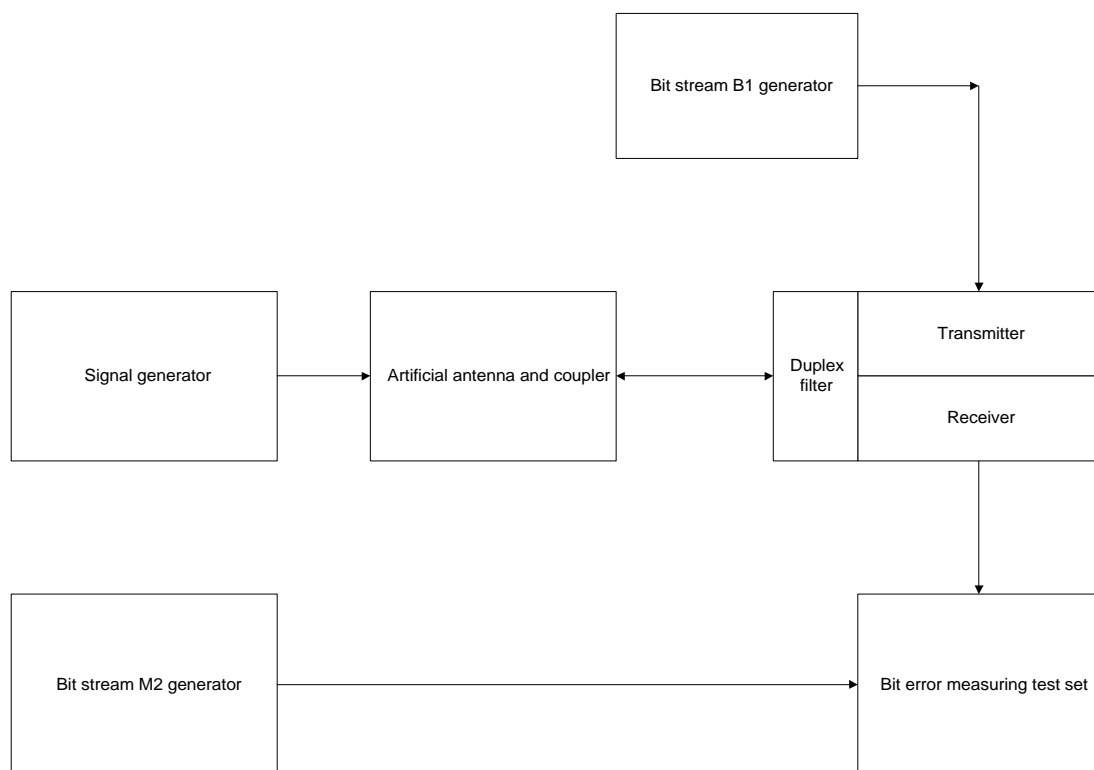

**Figure 17: Measurement arrangement for digital equipment (messages) having a duplex filter**

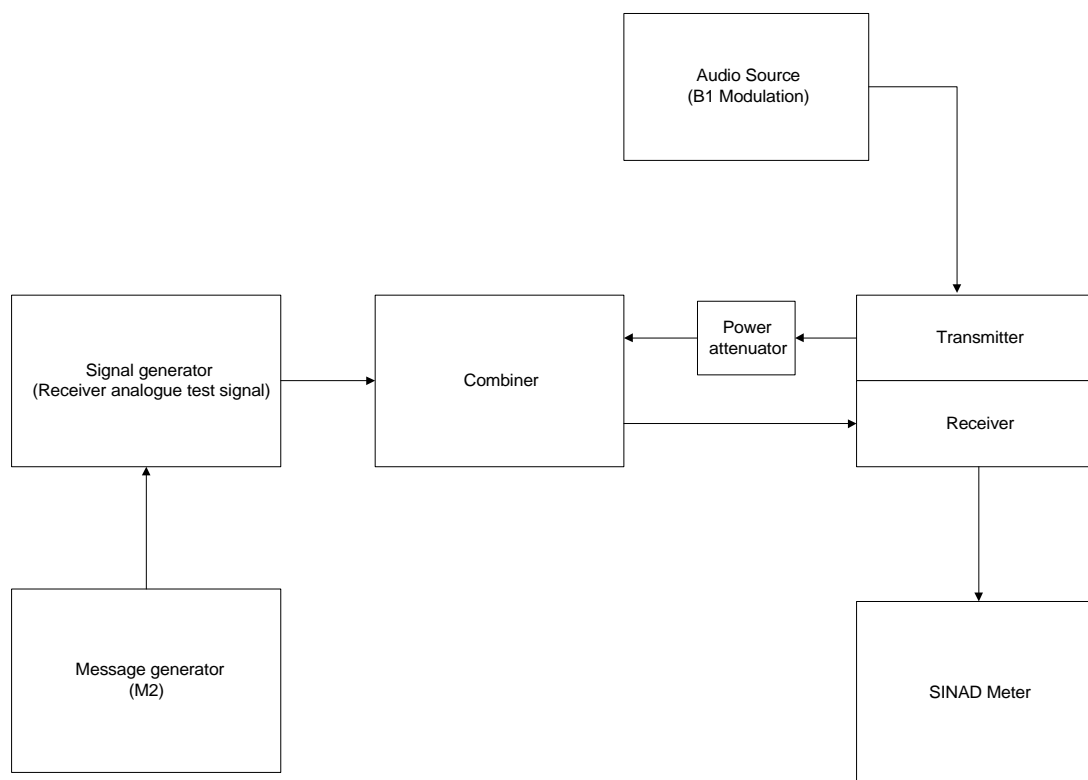

**Figure 18: Measurement arrangement for digital equipment (messages) having two antennas**

Spurious responses due to duplex operation (due to the active transmitter) are most likely to occur at frequencies  $f_{sd}$  derived from the following expressions:

$$- f_{sd} = | (f_r \pm p \times f_t) / q | \quad \text{and} \quad f_{sd} = | n \times f_t \pm f_{I1} |$$

where:

- $f_t$  is the transmitter frequency;
- $f_r$  is the receiver frequency; and
- $f_{I1}$  is the first IF of the receiver;
- $n, p, q$  are integers 1, 2, 3 ....

Normally it is sufficient to make the measurement with the unwanted signal set only to the following particular frequencies  $f_m$ :

$$- f_m = (f_r + f_t) / 2 ; \quad f_m = 2 | f_r + f_t | ; \quad f_m = f_t + f_{I1} ; \quad f_m = | f_t - f_{I1} | .$$

**NOTE:** Particular attention should be paid to avoiding measurement errors which might be caused by intermodulation effects in the generators, especially in generator B which provides the unwanted signal. To avoid such errors, care needs to be taken to attenuate sufficiently the transmitter power entering the signal generators via the combining networks. For this purpose the measurement arrangements, illustrated in figures 13 to 19 recommend the insertion of isolators. The insertion of a stop band filter for the transmitter frequency may serve the same purpose.

### 9.2.3 Limits

At any frequency separated from the nominal frequency of the receiver by two channels or more, the spurious response rejection ratio shall be greater than 67,0 dB.

## 10 Measurement uncertainty

Absolute measurement uncertainties: maximum values.

Valid up to 1 GHz for the RF parameters unless otherwise stated.

NOTE: These values may also be used between 1 GHz and 3 GHz.

- Frequency	$\pm 1 \times 10^{-7}$
- Maximum RF Power (conducted)	$\pm 0,75$ dB
- Maximum effective radiated power	$\pm 3$ dB
- Adjacent and alternate channels power	$\pm 5$ dB
- Conducted emission of transmitter	$\pm 4$ dB
- Conducted emission of transmitter, valid to 12,75 GHz	$\pm 7$ dB
- Audio output power	$\pm 0,5$ dB
- Sensitivity conducted	$\pm 3$ dB
- Sensitivity radiated	$\pm 6$ dB
- Conducted emission of receiver	$\pm 3$ dB
- Conducted emission of receiver, valid to 12,75 GHz	$\pm 6$ dB
- Two-signal measurement, valid to 4 GHz	$\pm 4$ dB
- Three-signal measurement	$\pm 3$ dB
- Radiated emission of transmitter, valid to 4 GHz	$\pm 6$ dB
- Radiated emission of receiver, valid to 4 GHz	$\pm 6$ dB
- Receiver desensitization (duplex operation)	$\pm 2$ dB

For the test methods according to the present document, the uncertainty figures are valid to a confidence level of 95 % calculated according to the methods described in ETR 028 [1].

## Annex A (normative): Radiated measurement

### A.1 Test sites and general arrangements for measurements involving the use of radiated fields

This normative annex introduces three most commonly available test sites, an anechoic chamber, an anechoic chamber with a ground plane and an Open Area Test Site (OATS), which may be used for radiated tests. These test sites are generally referred to as free field test sites. Both absolute and relative measurements can be performed in these sites. Where absolute measurements are to be carried out, the chamber should be verified. A detailed verification procedure is described in ETR 273 [5] relevant parts 2, 3 and 4.

**NOTE:** To ensure reproducibility and traceability of radiated measurements only these test sites should be used in type test measurements.

#### A.1.1 Anechoic chamber

An anechoic chamber is an enclosure, usually shielded, whose internal walls, floor and ceiling are covered with radio absorbing material, normally of the pyramidal urethane foam type. The chamber usually contains an antenna support at one end and a turntable at the other. A typical anechoic chamber is shown in figure A.1.

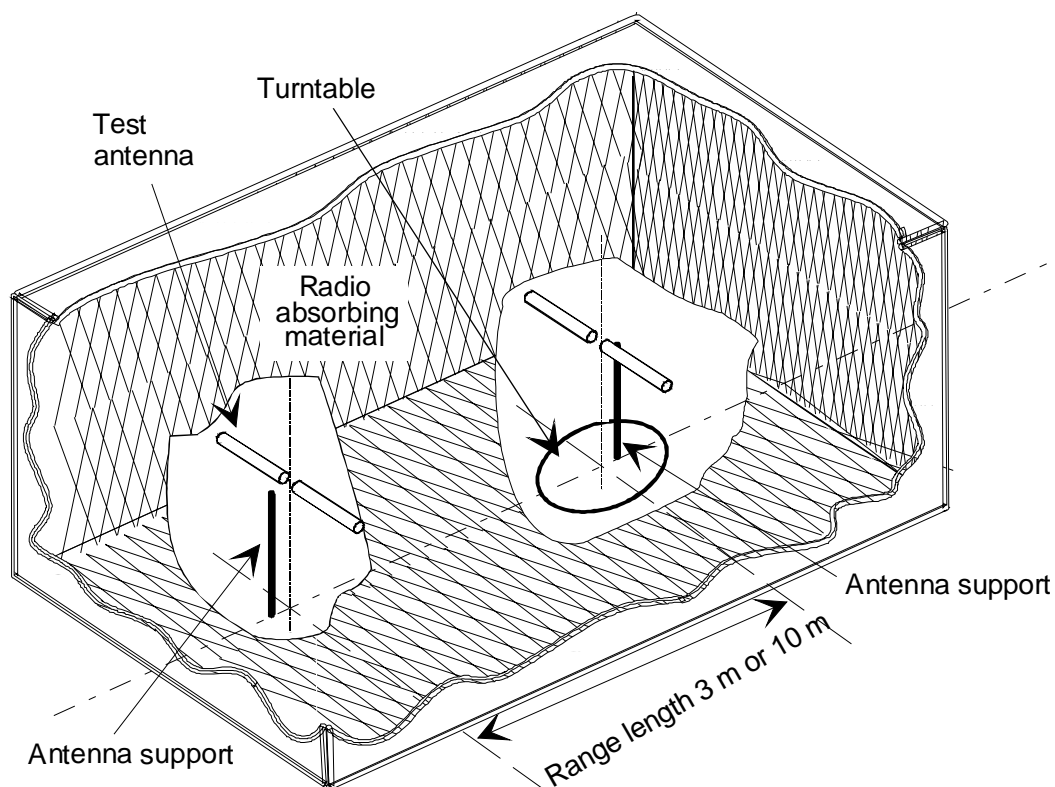

**Figure A.1: A typical anechoic chamber**



The chamber shielding and radio absorbing material work together to provide a controlled environment for testing purposes. This type of test chamber attempts to simulate free space conditions.

The shielding provides a test space, with reduced levels of interference from ambient signals and other outside effects, whilst the radio absorbing material minimizes unwanted reflections from the walls and ceiling which can influence the measurements. In practice it is relatively easy for shielding to provide high levels (80 dB to 140 dB) of ambient interference rejection, normally making ambient interference negligible.

A turntable is capable of rotation through 360° in the horizontal plane and it is used to support the test sample (EUT) at a suitable height (e.g. 1 m) above the ground plane. The chamber shall be large enough to allow the measuring distance of at least 3 m or  $2(d_1+d_2)^2/\lambda$  (m), whichever is greater (see clause A.2.5). The distance used in actual measurements shall be recorded with the test results.

The anechoic chamber generally has several advantages over other test facilities. There is minimal ambient interference, minimal floor, ceiling and wall reflections and it is independent of the weather. It does however have some disadvantages which include limited measuring distance and limited lower frequency usage due to the size of the pyramidal absorbers. To improve low frequency performance, a combination structure of ferrite tiles and urethane foam absorbers is commonly used.

All types of emission, sensitivity and immunity testing can be carried out within an anechoic chamber without limitation.

## A.1.2 Anechoic chamber with a ground plane

An anechoic chamber with a ground plane is an enclosure, usually shielded, whose internal walls and ceiling are covered with radio absorbing material, normally of the pyramidal urethane foam type. The floor, which is metallic, is not covered and forms the ground plane. The chamber usually contains an antenna mast at one end and a turntable at the other. A typical anechoic chamber with a ground plane is shown in figure A.2.

This type of test chamber attempts to simulate an ideal OATS whose primary characteristic is a perfectly conducting ground plane of infinite extent.

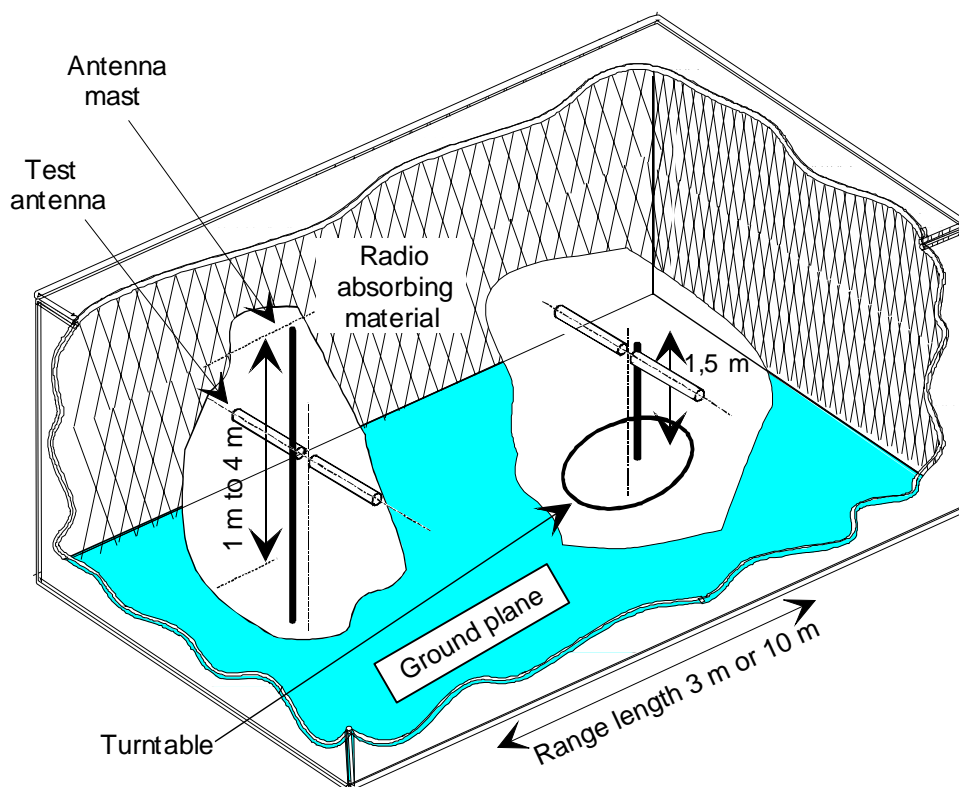

Figure A.2: A typical anechoic chamber with a ground plane

In this facility the ground plane creates the wanted reflection path, such that the signal received by the receiving antenna is the sum of the signals from both the direct and reflected transmission paths. This creates a unique received signal level for each height of the transmitting antenna (or EUT) and the receiving antenna above the ground plane.

The antenna mast provides a variable height facility (from 1 to 4 m) so that the position of the test antenna can be optimized for maximum coupled signal between antennas or between an EUT and the test antenna.

A turntable is capable of rotation through 360° in the horizontal plane and it is used to support the test sample (EUT) at a specified height, usually 1,5 m. above the ground plane. The chamber shall be large enough to allow the measuring distance of at least 3 m or  $2(d_1+d_2)^2/\lambda$  (m), whichever is greater (see clause A.2.5). The distance used in actual measurements shall be recorded with the test results.

Emission testing involves firstly "peaking" the field strength from the EUT by raising and lowering the receiving antenna on the mast (to obtain the maximum constructive interference of the direct and reflected signals from the EUT) and then rotating the turntable for a "peak" in the azimuth plane. At this height of the test antenna on the mast, the amplitude of the received signal is noted. Secondly the EUT is replaced by a substitution antenna (positioned at the EUT's phase or volume centre) which is connected to a signal generator. The signal is again "peaked" and the signal generator output adjusted until the level, noted in stage one, is again measured on the receiving device.

Receiver sensitivity tests over a ground plane also involve 'peaking' the field strength by raising and lowering the test antenna on the mast to obtain the maximum constructive interference of the direct and reflected signals, this time using a measuring antenna which has been positioned where the phase or volume centre of the EUT will be during testing. A transform factor is derived. The test antenna remains at the same height for stage two, during which the measuring antenna is replaced by the EUT. The amplitude of the transmitted signal is reduced to determine the field strength level at which a specified response is obtained from the EUT.

### A.1.3 OATS

An OATS comprises a turntable at one end and an antenna mast of variable height at the other end above a ground plane which, in the ideal case, is perfectly conducting and of infinite extent. In practice, whilst good conductivity can be achieved, the ground plane size has to be limited. A typical OATS is shown in figure A.3.

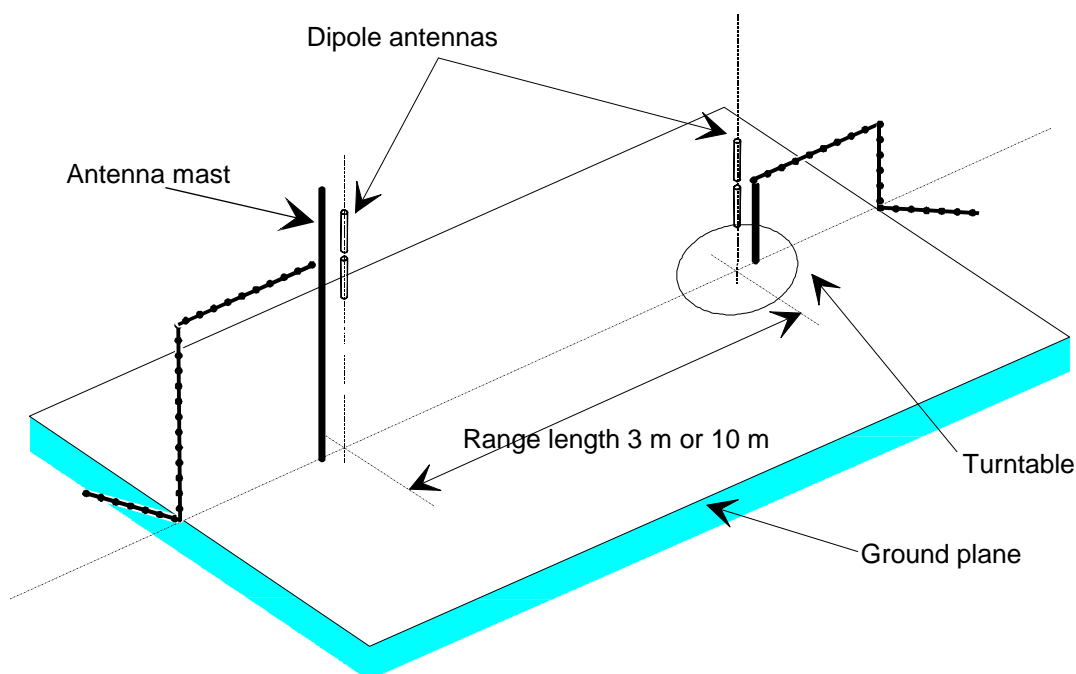
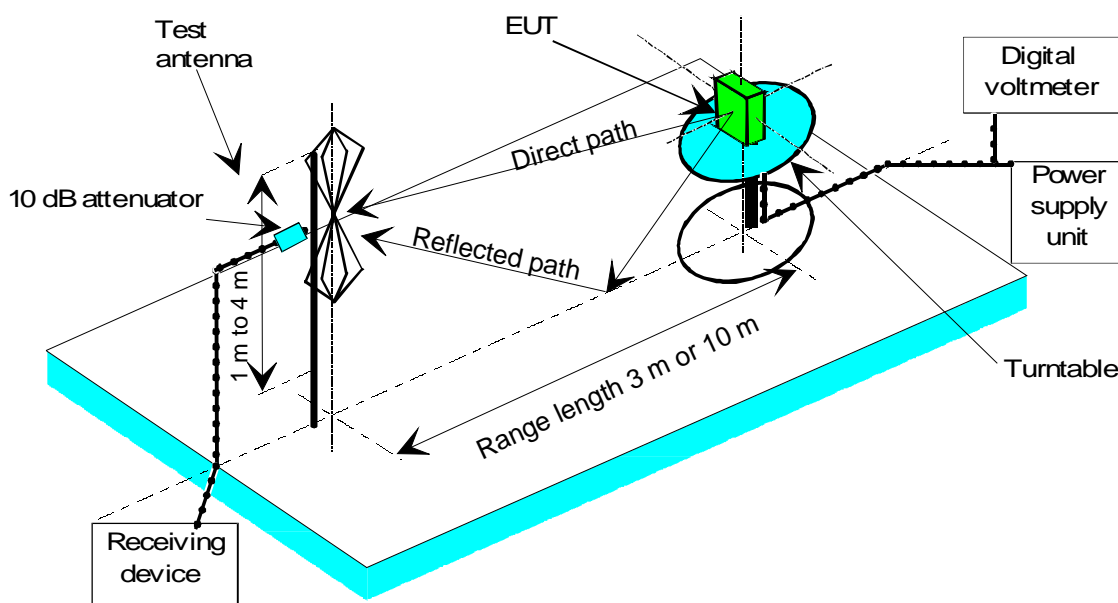

Figure A.3: A typical OATS

The ground plane creates a wanted reflection path, such that the signal received by the receiving antenna is the sum of the signals received from the direct and reflected transmission paths. The phasing of these two signals creates a unique received level for each height of the transmitting antenna (or EUT) and the receiving antenna above the ground plane.

Site qualification concerning antenna positions, turntable, measurement distance and other arrangements are same as for anechoic chamber with a ground plane. In radiated measurements an OATS is also used by the same way as anechoic chamber with a ground plane.

Typical measuring arrangement common for ground plane test sites is presented in figure A.4.



**Figure A.4: Measuring arrangement on ground plane test site (OATS set-up for spurious emission testing)**

## A.1.4 Test antenna

A test antenna is always used in radiated test methods. In emission tests (i.e. frequency error, effective radiated power, spurious emissions and adjacent channel power) the test antenna is used to detect the field from the EUT in one stage of the measurement and from the substitution antenna in the other stage. When the test site is used for the measurement of receiver characteristics (i.e. sensitivity and various immunity parameters) the antenna is used as the transmitting device.

The test antenna should be mounted on a support capable of allowing the antenna to be used in either horizontal or vertical polarization which, on ground plane sites (i.e. anechoic chambers with ground planes and OATS), should additionally allow the height of its centre above the ground to be varied over the specified range (usually 1 m to 4 m).

In the frequency band 30 MHz to 1 000 MHz, dipole antennas (constructed in accordance with ANSI C63.5 [7]) are generally recommended. For frequencies of 80 MHz and above, the dipoles should have their arm lengths set for resonance at the frequency of test. Below 80 MHz, shortened arm lengths are recommended. For spurious emission testing, however, a combination of bicones and log periodic dipole array antennas (commonly termed "log periodics") could be used to cover the entire 30 MHz to 1 000 MHz band. Above 1 000 MHz, waveguide horns are recommended although, again, log periodics could be used.

NOTE: The gain of a horn antenna is generally expressed relative to an isotropic radiator.

## A.1.5 Substitution antenna

The substitution antenna is used to replace the EUT for tests in which a transmitting parameter (i.e. frequency error, effective radiated power, spurious emissions and adjacent channel power) is being measured. For measurements in the frequency band 30 MHz to 1 000 MHz, the substitution antenna should be a dipole antenna (constructed in accordance with ANSI C63.5 [7]). For frequencies of 80 MHz and above, the dipoles should have their arm lengths set for resonance at the frequency of test. Below 80 MHz, shortened arm lengths are recommended. For measurements above 1 000 MHz, a waveguide horn is recommended. The centre of this antenna should coincide with either the phase centre or volume centre (as specified in the test method) of the EUT it has replaced.

## A.1.6 Measuring antenna

The measuring antenna is used in tests on an EUT in which a receiving parameter (i.e. sensitivity and various immunity tests) is being measured. Its purpose is to enable a measurement of the electric field strength in the vicinity of the EUT. For measurements in the frequency band 30 MHz to 1 000 MHz, the measuring antenna should be a dipole antenna (constructed in accordance with ANSI C63.5 [7]). For frequencies of 80 MHz and above, the dipoles should have their arm lengths set for resonance at the frequency of test. Below 80 MHz, shortened arm lengths are recommended. The centre of this antenna should coincide with either the phase centre or volume centre (as specified in the test method) of the EUT.

---

## A.2 Guidance on the use of radiation test sites

This clause details procedures, test equipment arrangements and verification that should be carried out before any of the radiated test are undertaken. These schemes are common to all types of test sites described in this annex.

### A.2.1 Verification of the test site

No test should be carried out on a test site which does not possess a valid certificate of verification. The verification procedures for the different types of test sites described in this annex (i.e. anechoic chamber, anechoic chamber with a ground plane and OATS) are given in ETR 273 [5] parts 2, 3 and 4, respectively.

### A.2.2 Preparation of the EUT

The manufacturer should supply information about the EUT covering the operating frequency, polarization, supply voltage(s) and the reference face. Additional information, specific to the type of EUT should include, where relevant, carrier power, CSP, whether different operating modes are available (e.g. high and low power modes) and if operation is continuous or is subject to a maximum test duty cycle (e.g. 1 m on, 4 m off).

Where necessary, a mounting bracket of minimal size should be available for mounting the EUT on the turntable. This bracket should be made from low conductivity, low relative dielectric constant (i.e. less than 1,5) material(s) such as expanded polystyrene, balsawood, etc.

### A.2.3 Power supplies to the EUT

All tests should be performed using power supplies wherever possible, including tests on EUT designed for battery-only use. In all cases, power leads should be connected to the EUT's supply terminals (and monitored with a digital voltmeter) but the battery should remain present, electrically isolated from the rest of the equipment, possibly by putting tape over its contacts.

The presence of these power cables can, however, affect the measured performance of the EUT. For this reason, they should be made to be "transparent" as far as the testing is concerned. This can be achieved by routing them away from the EUT and down to the either the screen, ground plane or facility wall (as appropriate) by the shortest possible paths. Precautions should be taken to minimize pick-up on these leads (e.g. the leads could be twisted together, loaded with ferrite beads at 0,15 m spacing or otherwise loaded).

Details shall be included in the test report.

### A.2.4 Volume control setting for analogue speech tests

Unless otherwise stated, in all receiver measurements for analogue speech the receiver volume control where possible, should be adjusted to give at least 50 % of the rated audio output power. In the case of stepped volume controls, to volume control should be set to the first step that provides an output power of at least 50 % of the rated audio output power. This control should not be readjusted between normal and extreme test conditions in tests.

## A.2.5 Range length

The range length for all these types of test facility should be adequate to allow for testing in the far-field of the EUT i.e. it should be equal to or exceed:

$$\frac{2(d_1+d_2)^2}{\lambda}$$

where:

- $d_1$  is the largest dimension of the EUT/dipole after substitution (m);
- $d_2$  is the largest dimension of the test antenna (m);
- $\lambda$  is the test frequency wavelength (m).

It should be noted that in the substitution part of this measurement, where both test and substitution antennas are half wavelength dipoles, this minimum range length for far-field testing would be:

$$2\lambda$$

It should be noted in the test report when either of these conditions is not met so that the additional measurement uncertainty can be incorporated into the results.

NOTE 1: **For the fully anechoic chamber**, no part of the volume of the EUT should, at any angle of rotation of the turntable, fall outside the "quiet zone" of the chamber at the nominal frequency of the test.

NOTE 2: The "quiet zone" is a volume within the anechoic chamber (without a ground plane) in which a specified performance has either been proven by test, or is guaranteed by the designer/manufacture. The specified performance is usually the reflectivity of the absorbing panels or a directly related parameter (e.g. signal uniformity in amplitude and phase). It should be noted however that the defining levels of the quiet zone tend to vary.

NOTE 3: **For the anechoic chamber with a ground plane**, a full height scanning capability, i.e. 1 m to 4 m, should be available for which no part of the test antenna should come within 1 m of the absorbing panels. For both types of **anechoic chamber**, the reflectivity of the absorbing panels should not be worse than -5 dB.

NOTE 4: **For both the anechoic chamber with a ground plane and the OATS**, no part of any antenna should come within 0,25 m of the ground plane at any time throughout the tests. Where any of these conditions cannot be met, measurements should not be carried out.

## A.2.6 Site preparation

The cables for both ends of the test site should be routed horizontally away from the testing area for a minimum of 2 m (unless, in the case both types of **anechoic chamber**, a back wall is reached) and then allowed to drop vertically and out through either the ground plane or screen (as appropriate) to the test equipment. Precautions should be taken to minimize pick up on these leads (e.g. dressing with ferrite beads, or other loading). The cables, their routing and dressing should be identical to the verification set-up.

NOTE: For ground reflection test sites (**i.e. anechoic chambers with ground planes and OATS**) which incorporate a cable drum with the antenna mast, the 2 m requirement may be impossible to comply with.

Calibration data for all items of test equipment should be available and valid. For test, substitution and measuring antennas, the data should include gain relative to an isotropic radiator (or antenna factor) for the frequency of test. Also, the VSWR of the substitution and measuring antennas should be known.

The calibration data on all cables and attenuators should include insertion loss and VSWR throughout the entire frequency range of the tests. All VSWR and insertion loss figures should be recorded in the log book results sheet for the specific test.

Where correction factors/tables are required, these should be immediately available.

For all items of test equipment, the maximum errors they exhibit should be known along with the distribution of the error e.g.:

- cable loss:  $\pm 0,5$  dB with a rectangular distribution;
- measuring receiver: 1,0 dB (standard deviation) signal level accuracy with a Gaussian error distribution.

At the start of measurements, system checks should be made on the items of test equipment used on the test site.

---

## A.3 Coupling of signals

### A.3.1 General

The presence of leads in the radiated field may cause a disturbance of that field and lead to additional measurement uncertainty. These disturbances can be minimized by using suitable coupling methods, offering signal isolation and minimum field disturbance (e.g. optical and acoustic coupling).

### A.3.2 Data signals

Isolation can be provided by the use of optical, ultra sonic or infra red means. Field disturbance can be minimized by using a suitable fibre optic connection. Ultra sonic or infra red radiated connections require suitable measures for the minimization of ambient noise.

### A.3.3 Speech and analogue signals

Where an audio output socket is not available an acoustic coupler should be used.

When using the acoustic coupler, care should be exercised that possible ambient noise does not influence the test result.

#### A.3.3.1 Acoustic coupler description

The acoustic coupler comprises a plastic funnel, an acoustic pipe and a microphone with a suitable amplifier. The materials used to fabricate the funnel and pipe should be of low conductivity and of low relative dielectric constant (i.e. less than 1,5).

- the acoustic pipe should be long enough to reach from the EUT to the microphone which should be located in a position that will not disturb the RF field. The acoustic pipe should have an inner diameter of about 6 mm and a wall thickness of about 1,5 mm and should be sufficiently flexible so as not to hinder the rotation of the turntable;
- the plastic funnel should have a diameter appropriate to the size of the loudspeaker in the EUT, with soft foam rubber glued to its edge, it should be fitted to one end of the acoustic pipe and the microphone should be fitted to the other end. It is very important to fix the centre of the funnel in a reproducible position relative to the EUT, since the position of the centre has a strong influence on the frequency response that will be measured. This can be achieved by placing the EUT in a close fitting acoustic mounting jig, supplied by the manufacturer, of which the funnel is an integral part;

- the microphone should have a response characteristic flat within 1 dB over a frequency range of 50 Hz to 20 kHz, a linear dynamic range of at least 50 dB. The sensitivity of the microphone and the receiver audio output level should be suitable to measure a signal to noise ratio of at least 40 dB at the nominal audio output level of the EUT. Its size should be sufficiently small to couple to the acoustic pipe;
- the frequency correcting network should correct the frequency response of the acoustic coupler so that the acoustic SINAD measurement is valid (see IEC 60489-3 appendix F [4]).

### A.3.3.2 Calibration

The aim of the calibration of the acoustic coupler is to determine the acoustic SINAD ratio which is equivalent to the SINAD ratio at the receiver output.

---

## Annex B (normative): Spectrum analyser specification

Methods of measurement in clause 7.3 refer to the use of a spectrum analyser. The characteristics of the spectrum analyser shall meet at least the following requirements:

- the reading accuracy of the frequency marker shall be within  $\pm 100$  Hz;
- the accuracy of relative amplitude measurements shall be within  $\pm 3,5$  dB.

It shall be possible to adjust the spectrum analyser to allow the separation on its screen of two equal amplitude components with a frequency difference of 100 Hz.

For statistically distributed modulations, the spectrum analyser and the integrating device (when appropriate) needs to allow determination of the power spectral density (energy per time and bandwidth), which has to be integrated over the bandwidth in question.

The spectrum analyser should have a dynamic range greater than 90 dB and the average phase noise in the adjacent and alternate channels shall be such that measurement of adjacent and alternate channel power (see clause 7.3) is not limited by phase noise. In order to confirm this the selected measurement technique for clause 7.3.2 shall be used to measure the adjacent and alternate channel power with a CW signal source with phase noise of less than -120 dBc/Hz at one CSP offset and -130 dBc/Hz at two CSP offset. The maximum adjacent channel power observed with these conditions shall not exceed -70 dBc, and the maximum alternate channel power measured with these conditions shall not exceed -80 dBc.



## Annex C (normative): Graphical representation of the selection of equipment and frequencies for testing

### C.1 Tests on a single sample

If the OFR of each equipment corresponds to its alignment range (AR0, AR1, AR2, or AR3) then only one sample shall be tested.

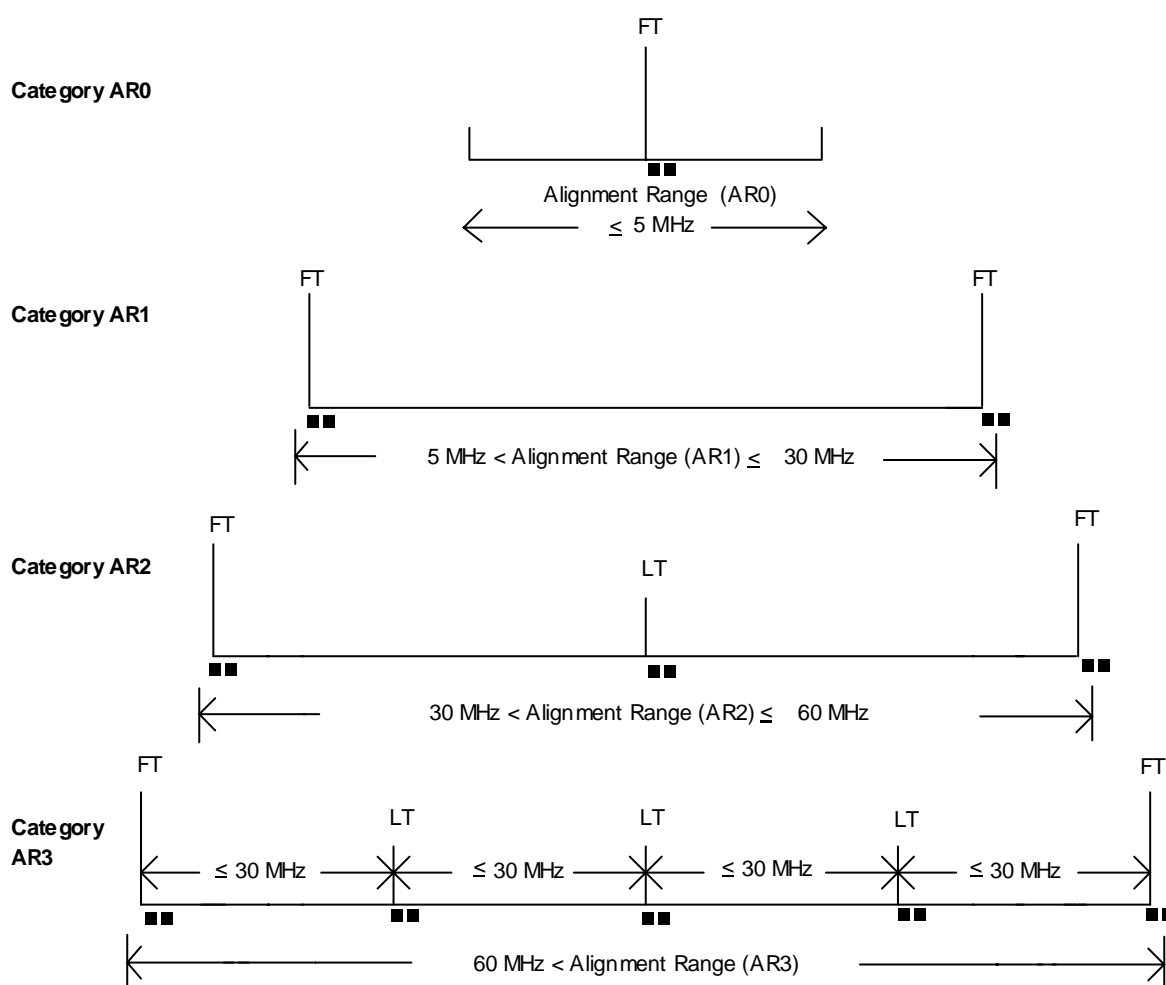

NOTE:

- AR0 First category of alignment range, see clause 4.1.3.
- AR1 Second category of alignment range, see clause 4.1.3.
- AR2 Third category of alignment range, see clause 4.1.3.
- AR3 Fourth category of alignment range, see clause 4.1.3.
- LT Limited tests.
- FT Full tests.
- ■ 50 kHz range in which tests are carried out.

**Figure C.1: Tests on a single sample for equipment that has a SR equal to its alignment range**

## C.2 Tests and samples needed when the SR is a subset of the alignment range

In order to cover an alignment range several separate samples, having different SR within the AR, may be needed. Samples shall be then provided for testing in accordance with clauses 4.1.4, 4.1.5, 4.1.6, and 4.1.7, as appropriate. The following examples assume a SR of 5 MHz.

### Category AR1

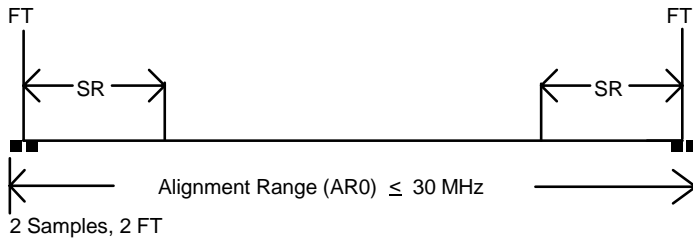

### Category AR2

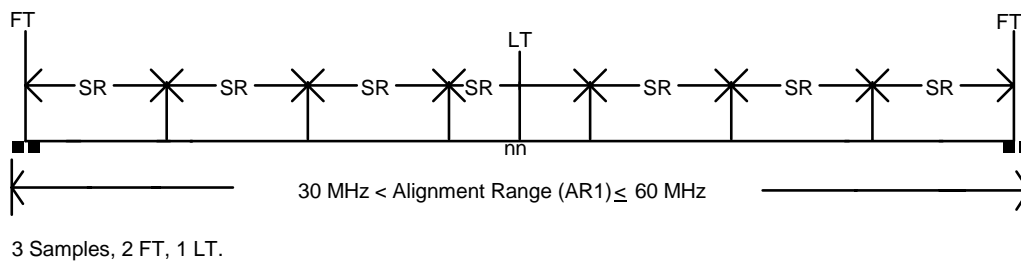

### Category AR3

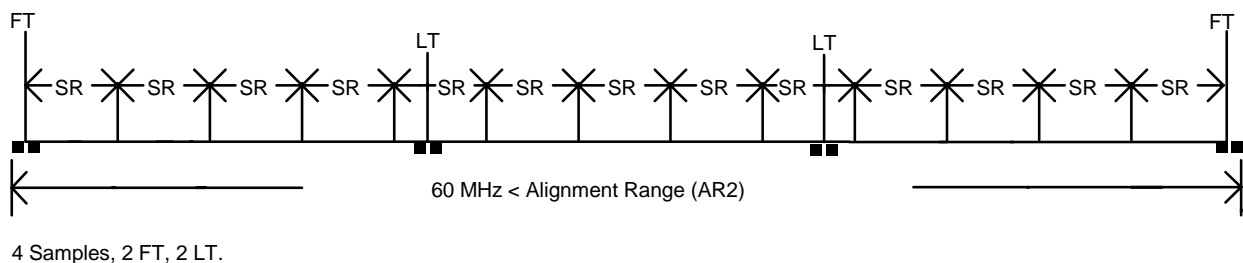

#### NOTE:

- SR        Switching Range, see clause 4.1.2.
- AR1      Second category of alignment range, see clause 4.1.3.
- AR2      Third category of alignment range, see clause 4.1.3.
- LT        Limited tests.
- FT        Full tests.
- ■      50 kHz range in which tests are carried out.

**Figure C.2: Tests on equipment having SR that are subsets of their alignment range**

## C.3 Tests and samples for a family of equipment where the alignment range is a subset of the total OFR

If the alignment range of a piece of equipment is a subset of the total OFR then the OFR shall be divided into appropriate categories of alignment range. Samples shall be then provided for testing in accordance with clauses 4.1.4, 4.1.5, 4.1.6, and 4.1.7, as appropriate.

For example the applicant seeks type approval for a family of equipment having an OFR of 403 MHz to 460 MHz. The equipment to be tested does not cover this range with one category of alignment range.

### C.3.1 Test scenario 1

The OFR could be covered by two alignment ranges a) and b):

- a) 403 MHz to 430 MHz: This is category AR1;
- b) 425 MHz to 470 MHz: This is category AR2.

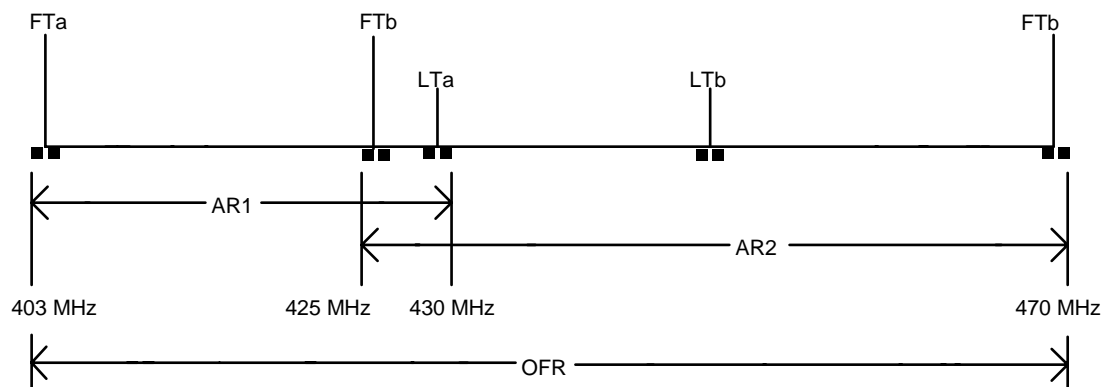

NOTE:

OFR	Operational frequency range, see clause 4.1.2.
AR1	Second category of alignment range, see clause 4.1.3.
AR2	Third category of alignment range, see clause 4.1.3.
FTa	Full tests on sample(s) a).
LTa	Limited tests on sample(s) a).
FTb	Full tests on sample(s) b).
LTb	Limited test on sample(s) a).
■ ■	50 kHz range in which tests are carried out.

This example requires a minimum of two test samples and a maximum of five test samples to cover the OFR.

**Figure C.3: Tests on family member equipment having alignment ranges that are subsets of the total OFR - (Example 1)**

## C.3.2 Test scenario 2

The OFR could alternatively be covered by three alignment ranges of category AR1:

- a) 403 MHz to 430 MHz: this is category AR1;
- b) 425 MHz to 450 MHz: this is category AR1;
- c) 450 MHz to 470 MHz: this is category AR1.

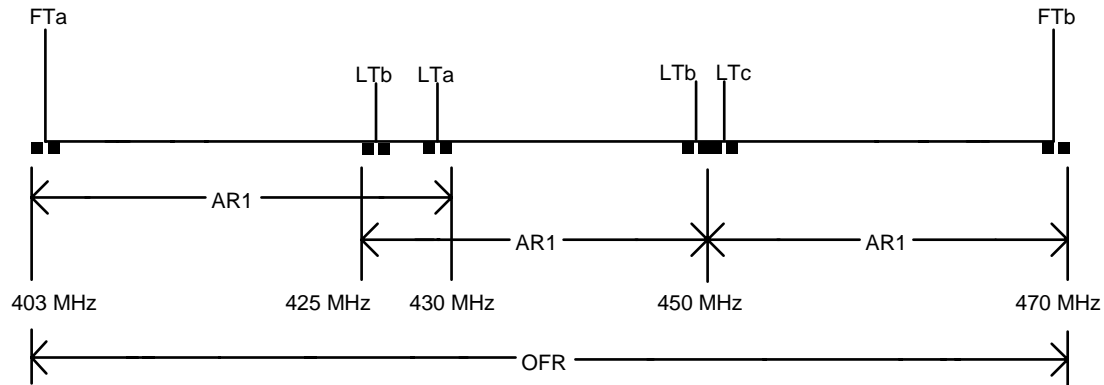

NOTE:

OFR	Operational frequency range, see clause 4.1.2.
AR1	Second category of alignment range, see clause 4.1.3.
FTa	Full tests on sample(s) a).
LTa	Limited tests on sample(s) a).
LTb	Limited test on sample(s) a).
FTc	Full tests on sample(s) c).
LTc	Limited tests on sample(s) c).
■ ■	50 kHz range in which tests are carried out.

This example requires a minimum of three test samples and a maximum of six test samples to cover the OFR.

**Figure C.4: Tests on family member equipment having alignment ranges that are subsets of the total OFR - (Example 2)**

## Annex D (normative): Specification for measurement filter

Methods of measurement in clause 7.6 refer to the use of a filter. The IF filter shall be within the limits of the selectivity characteristic of figure D.1.

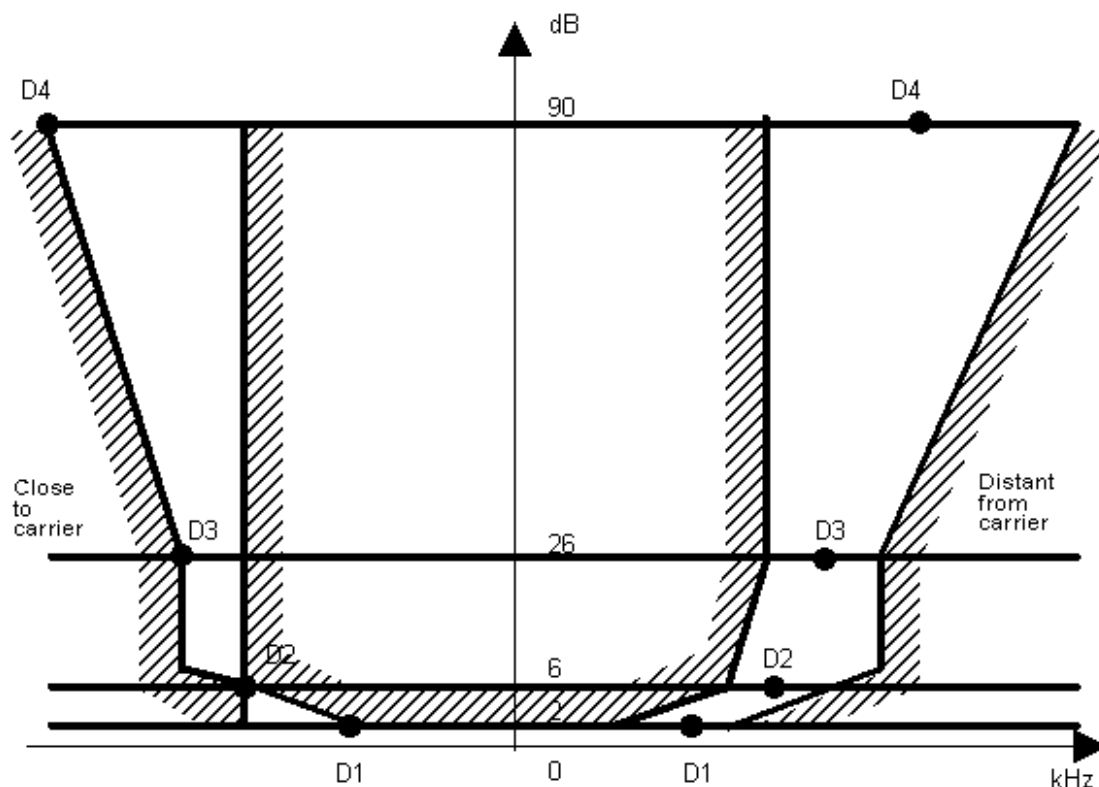

Figure D.1: IF filter

The selectivity characteristic shall keep the frequency separations from the nominal centre frequency of the adjacent channel as stated in table D.1.

Table D.1: Selectivity characteristic

Frequency separation of filter curve from nominal centre frequency of adjacent channel (kHz)			
D1	D2	D3	D4
3	4,25	5,5	9,5

The attenuation points shall not exceed the tolerances as stated in tables D.2 and D.3.

Table D.2: Attenuation points close to carrier

Tolerances range (kHz)			
D1	D2	D3	D4
+1,35	± 0,1	-1,35	-5,35

**Table D.3: Attenuation points distant from the carrier**

Tolerance range (kHz)			
D1	D2	D3	D4
$\pm 2,0$	$\pm 2,0$	$\pm 2,0$	+2,0 -6,0

The minimum attenuation of the filter, outside the 90 dB attenuation points, shall greater than or equal to 90 dB.

---

## Annex E (normative): Identification

The requirements set out in this annex are optional. This annex presents the technical characteristics to be fulfilled, when required by the appropriate national regulatory authorities, for the identification of stations type approved for private mobile radio systems, that do not comply with other system protocols (e.g. trunking protocols). It is the responsibility of the manufacturer to ensure that the modulation that he has chosen for the identification, in accordance with the tables of this annex fulfils all the requirements specified in the main body of the present document. The tables of this annex are expected to be updated regularly in order to reflect the progress accomplished in the field of mobile data transmissions.

Alternative methods of identification, not specified herein, should be considered as no less valid than the solution presented here, for example station identification by voice or international Morse Code.

---

### E.1 Scope

The identification code shall fulfil the specifications given in this annex unless identification is included in a system protocol approved by the appropriate administration. It shall also be used by combined analogue/digital equipment in the case of analogue transmissions.

---

### E.2 General

The design of a mobile system depends upon the requirements of that system, the evolution of technology and the specific needs and/or requirements of each country. When possible, the identification code would use the same techniques as the transmission of the user information itself. Therefore, a variety of possibilities have been presented in this annex. They are presented using several item tables and/or cross-tables:

- modulation, (indicating speed, channel separation and modulation): table E.1;
- bit sync (if needed) and synchronization word: table E.2;
- redundancy code and length of the useful bits protected by that code (CRC): table E.3;
- header of the ID (length and contents shall be unique to avoid ambiguous situations): table E.4;
- country code and length of national information: table E.5;
- national information subdivided in fields: table E.6 (table E.7 and figures E.2 to E.6);
- combinations of the previous items that could be used: table E.8;
- combinations that will in fact be used in the various countries: table E.9;
- organization of the fields that will in fact be used in the various countries: table E.10.

These tables can be used by manufacturers for the design of the equipment, for the type approval of the equipment and by the monitoring stations for the analysis of the identification of the transmissions.

---

## E.3 Position of the identification code

Considering that a receiver in the monitoring service is often operated in scanning mode and stops on a detected carrier, the identification code is transmitted as described below.

### E.3.1 Base stations

For base stations the identification ID shall be transmitted at the beginning and end of each session, at the end of the corresponding packets. If the session lasts for more than 3 minutes, an ID will also be transmitted at the end of the first transmitted packet after the 3 minutes has elapsed since the last transmission of the ID ("the 3 minutes rule"). There is no need for more than one ID per packet, unless 3 minutes have elapsed since the last transmission of the ID.

#### E.3.1.1 System without windows

In the case of continuous transmissions, the 3 minutes rule shall apply (not more than 3 minutes between transmissions of the ID).

#### E.3.1.2 Systems with windows

In the case of windows of less than 3 minutes, the ID shall also be sent at the end of the first packet of each window.

In the case of windows of more than 3 minutes, the ID shall, in addition, be sent according to the "3 minutes rule".

### E.3.2 Handportable and mobile stations

The same rule as for the base stations applies except that a handportable or a mobile only transmitting to a base station (BS) with a transmission shorter than 300 ms (e.g. the duration of a data burst), does not have to transmit its ID systematically in each session. Instead, the 3 minute rule applies, as follows:

- the ID shall be sent at the end of the first packet to be sent after 3 minutes have elapsed since the last transmission of the ID.



## E.4 Bit rates and modulations

Using the following table, demodulation can be performed, producing a bit stream. In the case of sub-carrier modulation (indirect modulation), the carrier can be modulated in phase (/ph.) or frequency (/frq.).

**Table E.1: Bit rate and modulation schemes**

Name	Bit Rate (b/s)	Channel separation (kHz)	Modulation (or reference)	Details (or reference)
MM12n6 /ph. /frq.	1 200	6,25	MSK (FFSK)	0 = 1 800 Hz, 1 = 1 200 Hz
MM12n5 /ph. /frq.	1 200	5	MSK (FFSK)	0 = 1 800 Hz, 1 = 1 200 Hz
MV12n6	1 200	6,25	ITU-T Recommendation V 22	4 phase state
MV12n6	1 200	6,25	ITU-T Recommendation V 23	0 = 2 100 Hz, 1 = 1 300 Hz
MV22n5	1 200	5	ITU-T Recommendation V 22	4 phase state
MV23n5	1 200	5	ITU-T Recommendation V 23	0 = 2 100 Hz, 1 = 1 300 Hz
MMO12n6	1 200	6,25	MSK (FFSK)	0 = 1 350 Hz, 1 = 750 Hz (At RF 0 = $f_c + 600$ Hz 1 = $f_c + 1 200$ Hz)
MMO12n5	1 200	5	MSK (FFSK)	0 = 1 350 Hz, 1 = 750 Hz (At RF 0 = $f_c + 600$ Hz 1 = $f_c + 1 200$ Hz)
MD24n6	2 400	6,25	Direct	
MD24n5	2 400	5	Direct	
MD48n6	4 800	6,25	Direct	
MD48n6	4 800	5	Direct	
MD72n6	7 200	6,25	Direct	
MD72n5	7 200	5	Direct	
MD80n6	8 000	6,25	Direct	
MD80n5	8 000	5	Direct	
MD96n6	9 600	6,25	Direct	
MD96n5	9 600	5	Direct	
NOTE 1: The direct modulation includes modulation methods such as: GMSK, multilevel state FM, PLL-4-PSK, 8 PSK, QPSK, QAM.				
NOTE 2: Other modulation systems are under consideration and may be added later to this table if proven to provide better performance.				

## E.5 Format of the identification

The identification (ID) shall be transmitted in one block (see definitions in clause 3.1).

If bit rate/modulation of the users information and of the "ID" block are not the same, the block shall be preceded by "bit sync". If bit rate and modulation are the same, the "bit sync" is optional. However, it is well known that the auto-correlation properties of the "sync word" are calculated with respect to their corresponding "bit sync" (table E.2).

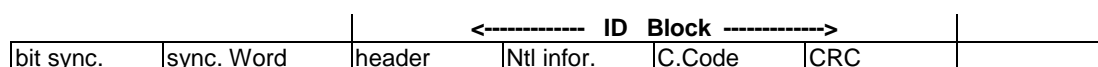

**Figure E.1: ID block organization**

## E.6 Synchronization

Using table E.2, the monitoring station receiver/decoder can be synchronized (detection of the beginning of each block) and bits can be extracted from the bit stream. Bits shall be transmitted in the order of Most Significant Bit (MSB) first.

**Table E.2: Synchronization**

bit sync (if needed)	Sync. word		Notes
	Name	Value	
1010 1010 1010 1010	S1	1011 0100 0011 0011	note 1
1010 1010 1010 1010	S2	0011 1011 0010 1000	
10 10 10 10	S3	1100 1110 00	note 2
01 01 01 01	S3'	0011 0001 11	note 2
1010 1010 1010 1010	S4	1100 0100 1101 0111	
1010 1010 1010 1010	S5	(1)010 0010 1111 0111	
	S6	(1)101 1101 0000 1000	
1010 1010 1010 1010	S7	1010 1111 0001 0010	

NOTE 1: This sync word has optimal autocorrelation properties.  
 NOTE 2: Frame synchronization comprises 10 bits with the structure:  
 S3 = transmissions Base to Handportable/Mobile;  
 S3' = transmissions Handportable/Mobile to Base.  
 Only these 10 bits are used for frame synchronization when handportables or mobiles evaluate base stations.  
 These 10 bits plus base identity (10 bits) in the scheme apply to all other communication with the current base as synchronization word for frame synchronization. Furthermore, four control flags are included in the synchronization word, i.e. the total length of the frame head is: 24 bits + bit sync.

NOTE: Table E.2 is valid in the case of modulations for which 101010 is an effective bit sync pattern. In the case of direct modulation methods for which the patterns given in table E.2 are not appropriate, the way in which entries of table E.2 have to be adapted to the constraints of a particular type of modulation, is to be agreed by the appropriate Administration.

## E.7 Code and block length

Using table E.3, the "useful" bits of each block can be counted and checked (error detection can be performed). Corrections could also be performed: a trade-off between detection and correction performance and notes concerning the code are proposed in column Det/Corr.

**Table E.3: Code and block length**

Name	Sizes	Notes	Details	Det/Corr
C1	(64,48)		$X^{15} + X^{14} + X^{13} + X^{11} + X^4 + X^2 + 1$ cyclic (63,48), LSB inv. +1 parity (even) bit appended	Det =< 5 errors
C2	(n+8,n)		$X^8 + X^7 + X^4 + 1$ all bits	
C3	(69,48)		Shortened cyclic	Det/Corr
C4	(16,8)	note 1	Block code: Corr 2 er.	
OC1	16*(8,4)	note 2	for "overcoding" the block in certain frequency bands parity check matrix: (01 -- -- --) (10 01 -- --) (10 10 01 --) (00 10 10 01)	Corr 2 err.

NOTE 1: Code C4 may be used in systems which need high protection and with a small amount of data to be transferred in a normal transmission. (6 blocks are needed to transmit the ID).  
 NOTE 2: Code OC1, in some frequency bands, may be used to protect all the bits of the block (in order to allow the correction of errors due to ignition noise, etc.). In the case where the code OC1 is used, the code C1 should only be used for error detection.

## E.8 Contents of the identification block

### E.8.1 Header

Using table E.4, the nature of the information contained in the block can be determined: ID or users/system information. Many of the combinations in this header are free for other use. Using such an organization could allow countries using only one block for the ID to use only first bit as ID (users/system) information flag, while leaving it open for other countries to use more bits. These bits could also be considered as part of the sync word for hunting purposes.

**Table E.4: Header information**

Name	Length	Binary	Interpretation
H1	4 bits	Hn2 = 0 0 x x	ID word to be used during the session (monitored on F1 or F2)
		Hn1 = 0 1 x x	ID word transmitting on F1; it can be used to activate the corresponding repeater
		Hd = 1 y x x	user/system information block; bits y and x are free for future use or for transmitting user/system information
NOTE: When a repeater is used, "F1" is the frequency used for the handportables and mobiles to transmit, "F2" is the output frequency of the repeater.			

## E.8.2 Country code

Table E.5 allows for the transcoding of the 5 bit OC field into the actual country where the ID has been allocated.

**Table E.5: Country codes**

Country code	Country	Length of Ntl info (if deviating from 39 bits) (see clause E.8.3)
00 000	Others	
01 111	Germany (Fed. Rep.)	41 bits
01 110	Andorra	(note 2)
11 001	Austria	
10 110	Baltic Republics	(note 2)
00 110	Bulgaria	(note 2)
01 100	Belgium	
11 101	Croatia	(note 2)
00 100	Cyprus	
00 011	Czech Republic	(note 2)
01 000	Denmark	
10 111	Spain	
01 110	Faroe Islands	(note 2)
01 011	Finland	
10 000	France	
10 011	Russia and countries from IEC not explicitly quoted in the table.	
00 111	Greece	
00 110	Hungary	(note 2)
11 110	Ireland	
11 000	Iceland	
01 010	Italy	
11 010	Liechtenstein	
11 011	Luxembourg	
11 101	Malta	(note 2)
11 111	Monaco	
01 101	Norway	
10 001	Netherlands	
10 101	Poland	
00 010	Portugal	
00 110	Romania	(note 2)
01 001	United Kingdom	
10 110	San Marino	(note 2)
00 011	Slovak Republic	(note 2)
11 101	Slovenia	(note 2)
10 010	Sweden	
00 101	Switzerland	
11 100	Turkey	
00 001	Vatican (City)	
10 100	Countries from ex-Yugoslavia not explicitly quoted in the table.	
NOTE 1: In the allocation some codes are missing due to recent developments in Europe; this table will be completed when possible in the future.		
NOTE 2: Two or more countries can use the same 5 bit CC code in which case the differentiation can be made using the LOF field ("Regional Licensing Office).		
NOTE 3: When mobiles from two or more countries are not expected to interfere with each other, then these countries can use the same 5 bit CC code.		

## E.8.3 National Information

The following options for the fields containing the "National" (Ntl) information are based on the assumption that the ID blocks contain 48 useful bits and provide 39 bits for the "National" information field (field Ntl info).

### E.8.3.1 Field description

The following fields can either be used for the purpose of identification and/or used for transmitting information corresponding to user data or system needs:

**Table E.6: Field description**

Category	No of bits
Licensee number	Lnb: 0 - 14
Individual transmitter identification	TID: 0 - 20
Network identification	NID: 14 - 20
Regional licensing office	LOF: 0 - 8
Relay station number	Rnb: 0 - 12
National Additional information	NAI: 0 - 20
User group	UG: 0 - 7
Field free for system or user data	FF:

The maximum total number of bits available in field F is 39 bits (however national information can go up to 41 bits by overflow of 2 bits into the header Hxx bits).

All categories are expected to be coded in binary (and will be presented in 4 bit nibbles).

### E.8.3.2 Field size options

**Table E.7: Field size options**

Name of the scheme	Field description		
	Size	Name	Usage
FZ1	7 bits	LOF	regional licensing office ID
	7 bits	UG	user group
	14 bits	NID	network identification
	13 bits	TID	individual transmitter ID
FZ2	5 bits	Rnb	relay number
	18 bits	NID	network ID
	12 bits	TID	individual mobile number
FZ3	27 bits	Lnb	licensee number
	14 bits	NID	network ID

### E.8.3.3 Options for the organization of the fields

bit	0	2	9	13	16	30	43
sync word	H Oy	UG 7 bits	LOFM 4 bits	LOFL 3 bits	NID 14 bits	TID 13 bits	CC 5 bits

**Figure E.2: FO1**

Bit	0	4	9	13	31	43
sync word	H Oyxx	Rnb 5 bits	FF 4 bits	NID 18 bits	TID 12 bits	CC 5 bits

**Figure E.3: FO2**

bit	0	2	29	43
sync word	H Oy	Lnb 27 bits	NID 14 bits	CC 5 bits

**Figure E.4: FO3**

bit	0	4	9	36	43
sync word	H Obxx	FF 5 bits	Lnb 27 bits	NID 7 bits	CC 5 bits

**Figure E.5: FO3b**

bit	0	4	9	13	17	31	43
sync word	H Obxx	Rnb 5 bits	FF 4 bits	Ext 4 bits	NID 14 bits	TID 12 bits	CC 5 bits

**Figure E.6: FO4**

Option F04, given in figure E.6 above, is a common representation where the extension (4 bits) could be either FF or LOFL or an extension for NID.

NOTE: "bit", in these tables, means the first bit of the corresponding field.

### E.8.3.4 Examples of user/system information usage

The bits of the ID block that have not been allocated in table E.6 (free fields "FF") can be:

- used for numbering the blocks in the packets (e.g. 3 bits);
- used as a function code (e.g. 2 bits);
- used for the transmission of status;
- used to transmit an acknowledge;
- used to transmit a no-acknowledge;
- used to clear down the repeater (deactivation of the repeater after an activation using, for instance, Header code Hn1).

## E.9 Combinations

Tables E.8 and E.9 indicate which of the combinations given in the "Items Tables" will in fact be used.

### E.9.1 List of possible combinations

Table E.8 indicates the "lower layer" combinations that have been explicitly supported by the regulatory authorities and that could be accepted in some countries. Knowing these formats and codes, NTL information can be easily accessed.

**Table E.8: Combinations table**

Modulation	Sync. Word	Code length	Header	Freq. Band	comb. name + notes
	S1	C1	H1(w/2 bit)		ACx
	S1	C1	H1	< 500 MHz	ACy
	S3 + S3'	C3	H1	< 1 000 MHz	ACzn, ACzw
	S7	C4	H1	< 500 MHz	ACtn, ACTw

NOTE: To be completed in the future.

### E.9.2 Relations between country code and allowed combinations

The following table indicates, among the combinations included in table E.8, those which are, or will soon be, effectively allowed in the different countries.

**Table E.9: Combinations in a country**

Country code	Allowed combinations	Notes
D 01 111		
And 01 110		
A 11 001		
B 01 100		
CY 00 100		
DK 01 000		
E 10 111		
SF 01 011		
F 10 000		
GR 00 111		
IRL11 110		
IS 11 000		
I 01 010		
FL 11 010		
L 11 011		
M 11 101		
MC 11 111		
N 01 101		
NL 10 001		
P 00 010		
GB 01 001		
SMR 10 110		
S 10 010		
CH 00 101		
TR 11 100		
SCV 00 001		
YU 10 100		

NOTE: Fs: further study is needed.

### E.9.3 Interpretation of the fields of the ID block

Using table E.10, interpretation of the various fields could be performed.

**Table E.10: Interpretation table**

Country code	Scheme for organization of NTL info (note 2)
D 01 111	
And 01 110	
A 11 001	
B 01 100	
CY 00 100	
DK 01 000	
E 10 111	
SF 01 011	
F 10 000	
GR 00 111	
IRL11 110	
IS 11 000	
I 01 010	
FL 11 010	
L 11 011	
M 11 101	
MC 11 111	
N 01 101	
NL 10 001	
P 00 010	
GB 01 001	
SMR 10 110	
S 10 010	
CH 00 101	
TR 11 100	
SCV 00 001	
YU 10 100	
NOTE 1: Fs: further study is needed.	
NOTE 2: For NTL information see clause E.8.3, including tables E.6 and E.7 and figures E.2 to E.6.	



---

## History

<b>Document history</b>		
V1.1.1	February 1999	Publication as EN 301 166
V1.1.2	December 2001	Publication