

**Intelligent Network (IN);  
Intelligent Network Application Protocol (INAP);  
Capability Set 2 (CS2);**

**Part 4: Abstract Test Suite (ATS) specification and Partial  
Protocol Implementation eXtra Information for Testing (PIXIT)  
proforma for Service Switching Function (SSF);  
Sub-part 1: Basic capability set of CS-1  
including CS-2 complements**

---



---

Reference

DEN/SPS-03038-4-1 (ak109idc.PDF)

---

Keywords

IN, CS1, INAP, ATS

**ETSI**

---

Postal address

F-06921 Sophia Antipolis Cedex - FRANCE

---

Office address

650 Route des Lucioles - Sophia Antipolis  
Valbonne - FRANCE  
Tel.: +33 4 92 94 42 00 Fax: +33 4 93 65 47 16  
Siret N° 348 623 562 00017 - NAF 742 C  
Association à but non lucratif enregistrée à la  
Sous-Préfecture de Grasse (06) N° 7803/88

---

Internet

[secretariat@etsi.fr](mailto:secretariat@etsi.fr)  
Individual copies of this ETSI deliverable  
can be downloaded from  
<http://www.etsi.org>  
If you find errors in the present document, send your  
comment to: [editor@etsi.fr](mailto:editor@etsi.fr)

---

**Copyright Notification**

No part may be reproduced except as authorized by written permission.  
The copyright and the foregoing restriction extend to reproduction in all media.

© European Telecommunications Standards Institute 1999.  
All rights reserved.

# Contents

Intellectual Property Rights.....	5
Foreword .....	5
1 Scope.....	6
2 References.....	6
3 Definitions and abbreviations .....	7
3.1 Definitions.....	7
3.2 Abbreviations .....	7
3.3 ISO 9646 definitions .....	7
3.4 ISO 9646 abbreviations.....	8
4 Test architecture.....	8
4.1 Abstract Test Method (ATM).....	8
4.2 Overall configuration.....	9
4.3 Test of SSF-SCF interface using INAP.....	9
4.4 Test of SCF-SCF interface using INAP.....	10
4.5 Points of control and observation (PCOs).....	10
4.6 Test system .....	10
4.7 Functional configurations .....	11
4.7.1 SSF-SCF interface .....	11
4.7.2 SCF-SCF interface.....	12
4.7.3 Reference to product implementation .....	12
4.8 Protocol primitives .....	13
4.8.1 Protocol primitives at PCO_1 and PCO_2.....	13
4.8.2 Protocol primitives at PCO_3_1 and PCO_3_2.....	14
5 ATS conventions.....	14
5.1 Naming conventions.....	14
5.1.1 Declarations part.....	14
5.1.1.1 Test suite type and structured type definitions By Reference.....	14
5.1.1.2 Test suite operations definitions.....	15
5.1.1.3 Test suite parameter declarations .....	15
5.1.1.4 Test case selection expression definitions.....	15
5.1.1.5 Test suite constant declarations By Reference .....	15
5.1.1.6 Test suite variable declarations .....	15
5.1.1.7 Test case variable declarations.....	15
5.1.1.8 Timer declarations.....	15
5.1.1.9 ASP type definitions.....	16
5.1.1.10 Alias definitions .....	16
5.1.2 Constraints part.....	16
5.1.3 Dynamic part .....	16
5.1.3.1 Test case identifier .....	17
5.1.3.2 Test step identifier.....	17
5.1.3.3 Preamble identifier.....	17
5.1.3.4 Postamble identifier .....	17
5.1.3.5 Default identifier .....	17
6 Implementation conventions .....	18
6.1 TC and TP mapping .....	18
7 ATS generalities.....	18
7.1 ATS design.....	18
7.1.1 Methodology.....	18
7.2 Test Configuration.....	19
7.2.1 Example .....	20
7.3 ATS restrictions.....	21

<b>Annex A (normative):</b>	<b>ATS for CS1 INAP (subset of the INAP CS2)</b>	<b>22</b>
A.1	The TTCN Graphical form (TTCN.GR)	22
A.2	The TTCN Machine Processable form (TTCN.MP)	22
<b>Annex B (normative):</b>	<b>Partial PIXIT proforma for INAP CS1 layer</b>	<b>23</b>
B.1	Identification summary	23
B.2	ATS summary	23
B.3	Test laboratory	23
B.4	Client identification	23
B.5	SUT	24
B.6	Protocol layer information	24
B.6.1	Protocol identification	24
B.6.2	IUT information	24
B.6.2.1	Implicit send events	24
B.6.2.2	Core INAP Parameter values	25
B.6.2.3	TCAP Parameter values	26
<b>Annex C (normative):</b>	<b>Protocol Conformance Test Report (PCTR) proforma for CORE INAP CS1 protocol layer</b>	<b>27</b>
C.1	Identification summary	27
C.1.1	Protocol conformance test report	27
C.1.2	IUT identification	27
C.1.3	Testing environment	27
C.1.4	Limits and reservation	28
C.1.5	Comments	28
C.2	IUT conformance status	28
C.3	Static conformance summary	28
C.4	Dynamic conformance summary	28
C.5	Static conformance review report	29
C.6	Test campaign report	30
C.7	Observations	32
	History	33

---

## Intellectual Property Rights

IPRs essential or potentially essential to the present document may have been declared to ETSI. The information pertaining to these essential IPRs, if any, is publicly available for **ETSI members and non-members**, and can be found in SR 000 314: "*Intellectual Property Rights (IPRs); Essential, or potentially Essential, IPRs notified to ETSI in respect of ETSI standards*", which is available **free of charge** from the ETSI Secretariat. Latest updates are available on the ETSI Web server (<http://www.etsi.org/ipr>).

Pursuant to the ETSI IPR Policy, no investigation, including IPR searches, has been carried out by ETSI. No guarantee can be given as to the existence of other IPRs not referenced in SR 000 314 (or the updates on the ETSI Web server) which are, or may be, or may become, essential to the present document.

---

## Foreword

This European Standard (Telecommunications series) has been produced by ETSI Technical Committee Services and Protocol for Advanced Networks (SPAN), and is now submitted for the Public Enquiry phase of the ETSI standards Two-step Approval Procedure.

The present document is part 4, sub-part 1 of a multi-part EN covering the Intelligent Network Application Protocol (INAP) capability set 2, as identified below:

- Part 1: "Protocol specification";
- Part 2: "Protocol Implementation Conformance Statement (PICS) proforma specification";
- Part 3: "Test Suite Structure and Test Purposes (TSS&TP) specification for Service Switching Function (SSF)";
- Part 4: "Abstract Test Suite (ATS) specification and Partial Protocol Implementation eXtra Information for Testing (PIXIT) proforma for Service Switching Function (SSF)";**
  - Sub-part 1: "Basic capability set of CS-1 including CS-2 complements";**
  - Sub-part 2: "Call Party Handling (CPH)";
  - Sub-part 3: "Specialized Resource Functions (SRF)";
- Part 5: "Distributed Functional Plane (DFP) [ITU-T Recommendation Q.1224 (1997) modified]".

<b>Proposed national transposition dates</b>	
Date of latest announcement of this EN (doa):	3 months after ETSI publication
Date of latest publication of new National Standard or endorsement of this EN (dop/e):	6 months after doa
Date of withdrawal of any conflicting National Standard (dow):	6 months after doa

---

# 1 Scope

The present document provides the Abstract Test Suite (ATS) for testing of the Service Switching Function (SSF) and the Specialized Resource Function (SRF) of the core Intelligent Network Application Protocol (INAP) according to EN 301 140-1 [1].

In this specific part 4-1, the part of Capability Set 2 (CS2) dealing with CS1 functions is covered.

Annex A provides the Tree and Tabular Combined Notation (TTCN).

Annex B provides the Partial Protocol Implementation eXtra Information for Testing (PIXIT) Proforma.

Annex C provides the Protocol Conformance Test Report (PCTR) Proforma.

The ISO standard for the methodology of conformance testing, ISO/IEC 9646-1 [4], ISO/IEC 9646-2 [5], ISO/IEC 9646-3 [6] and ISO/IEC 9646-5 [7], as well as the ETSI rules for conformance testing, ETS 300 406 [9] are used as a basis for the test methodology.

---

# 2 References

The following documents contain provisions which, through reference in this text, constitute provisions of the present document.

- References are either specific (identified by date of publication, edition number, version number, etc.) or non-specific.
- For a specific reference, subsequent revisions do not apply.
- For a non-specific reference, the latest version applies.
- A non-specific reference to an ETS shall also be taken to refer to later versions published as an EN with the same number.

- [1] EN 301 140-1 (V1.3): "Intelligent Network (IN); Intelligent Network Application Protocol (INAP); Capability Set 2 (CS2); Part 1: Protocol specification".
- [2] ETS 300 374-1: "Intelligent Network (IN); Intelligent Network Capability Set 1 (CS1); Core Intelligent Network Application Protocol (INAP); Part 1: Protocol specification".
- [3] ITU-T Recommendation Q.771: "Functional description of transaction capabilities".
- [4] ISO/IEC 9646-1: "Information technology - Open Systems Interconnection - Conformance testing methodology and framework - Part 1: General Concepts". (See also CCITT Recommendation X.290)
- [5] ISO/IEC 9646-2: "Information technology - Open Systems Interconnection - Conformance testing methodology and framework - Part 2: Abstract Test Suite Specification". (See also CCITT Recommendation X.291 (1991))
- [6] ISO/IEC 9646-3: "Information technology - Open Systems Interconnection - Conformance testing methodology and framework - Part 3: The Tree and Tabular Combined Notation (TTCN)". (See also CCITT Recommendation X.292 (1992)).
- [7] ISO/IEC 9646-5: "Information technology - Open Systems Interconnection - Conformance testing methodology and framework - Part 5: Requirements on test laboratories and clients for the conformance assessment process". (See also CCITT Recommendation X.292 (1992)).
- [8] ISO/IEC 9646-6: "Information technology - Open Systems Interconnection - Conformance testing methodology and framework - Part 6: Protocol profile test specification".
- [9] ETS 300 406: "Methods for Testing and Specification (MTS); Protocol and profile conformance testing specifications; Standardization methodology".

- [10] ITU-T Recommendation Q.1224 (1997): "Distributed functional plane for intelligent network Capability Set 2".
- [11] EN 301 140-2: "Intelligent Network (IN); Intelligent Network Application Protocol (INAP); Capability Set 2 (CS2); Part 2: Protocol Implementation Conformance Statement (PICS) proforma specification".

## 3 Definitions and abbreviations

### 3.1 Definitions

For the purposes of the present document, the following terms and definitions apply.

- terms defined in EN 301 140-1 [1];

### 3.2 Abbreviations

For the purposes of the present document, the following abbreviations apply:

BI	Invalid Behaviour tests
BO	Inopportune Behaviour tests
BV	Valid Behaviour tests
CA	Capability tests
CP	Co-ordination Point
CS	Capability Set
IN	Intelligent Network
INAP	Intelligent Network Application Protocol
IUT	Implementation Under Test
MSC	Message Sequence Chart
MTC	Master Test Component
PDU	Protocol Data Unit
PTC	Parallel Test Component
SCF	Service Control Function
SCP	Service Control Point
SDL	System Description Language
SRF	Specialized Resource Function
SSF	Service Switching Function
SSP	Service Switching Point
SUT	System Under Test
TCAP	Transaction Capabilities Application Part
TDP	Trigger Detection Point

### 3.3 ISO 9646 definitions

For the purposes of the present document the following ISO/IEC 9646-1 [4] definitions apply:

Abstract Test Suite (ATS)  
 Abstract Test Method (ATM)  
 Implementation Conformance Statement (ICS)  
 Implementation Under Test (IUT)  
 Implementation eXtra Information for Testing (IXIT)  
 Lower Tester (LT)  
 PICS proforma  
 PIXIT proforma  
 Point of Control and Observation (PCO)  
 Protocol Implementation Conformance Statement (PICS)  
 Protocol Implementation eXtra Information for Testing (PIXIT)

Service Access Point (SAP)  
 Single Party Testing (SPyT)  
 System Under Test (SUT)  
 Upper Tester (UT)

For the purposes of the present document the following ISO/IEC 9646-3 [5] definitions apply:

TTCN.GR  
 TTCN.MP

For the purposes of the present document the following ISO/IEC 9646-5 [7] definitions apply:

Protocol Conformance Test Report (PCTR)  
 PCTR proforma

### 3.4 ISO 9646 abbreviations

For the purposes of the present document the following ISO/IEC 9646-1 [4] abbreviations apply:

ASP	Abstract Service Primitive
ATM	Abstract Test Method
ATS	Abstract Test Suite
IUT	Implementation Under Test
LT	Lower Tester
NWK	Network Layer
PCO	Point of Control and Observation
PDU	Protocol Data Unit
PICS	Protocol Implementation Conformance Statements
PIXIT	Protocol Implementation eXtra Information for Testing
SAP	Service Access Point
SPyT	Single Party Testing
SUT	System Under Test
TC	Test Case
TP	Test Purpose
TTCN	Tree and Tabular Combined Notation
TSS	Test Suite Structure
UT	Upper Tester

For the purposes of the present document the following ISO/IEC 9646-5 [7] abbreviations apply:

PCTR            Protocol Conformance Test Report

## 4 Test architecture

### 4.1 Abstract Test Method (ATM)

This clause describes the ATM used for testing the INAP protocol. It is the embedded variant of the remote test method used in Multy Party Testing (MPyT) context, as defined in ISO/IEC 9646-2 [5]. This test method has been selected, because:

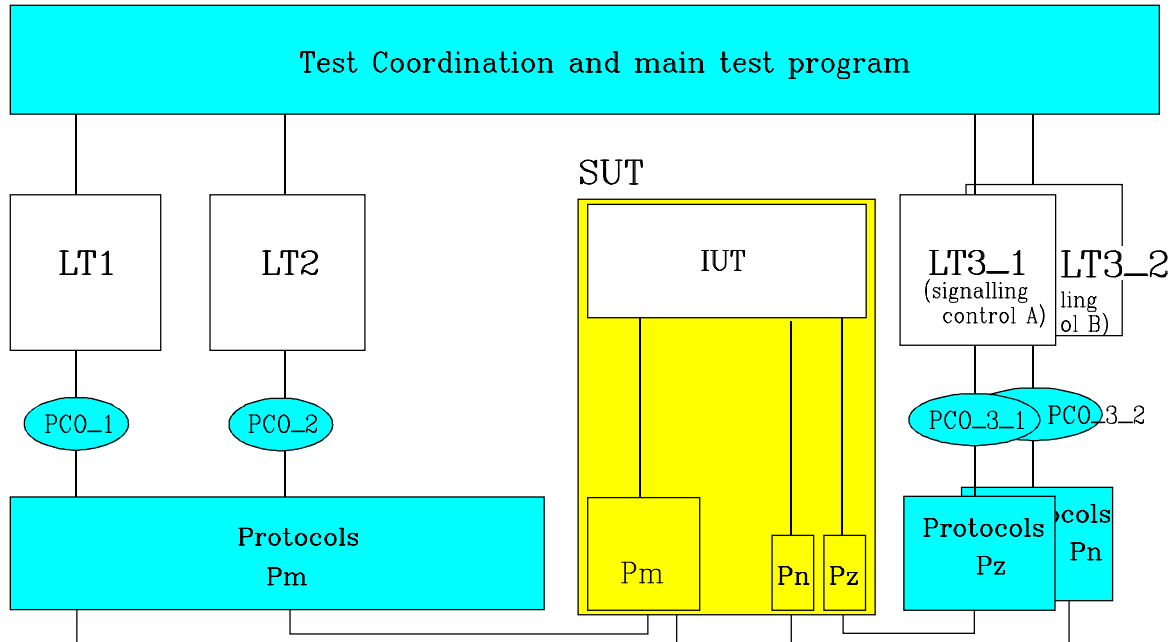
- this test method implies no specific requirements from the Implementation Under Test (IUT);
- the upper Service Access Point (SAP) of the IUT cannot be directly observed;
- this test method places minimum limitations in the realization of conformance testing.



## 4.2 Overall configuration

Figure 1 describes the test architecture which will be used for the definition of the ATS.

A single test architecture covers all testing configuration requirements.



**Figure 1: Multi-party, single-layer testing context: one IUT and 4 types of LTs**

Figure 1 shows the multi-party, single layer testing context. The same architecture can be used for testing several interfaces. The roles of IUT and LTs change according to the protocol to be tested in the IUT.

Table 1 gives the nature of the IUT and LTs according to the protocol under test.

**Table 1: possible testing configurations**

Test Config	Tested Interface	IUT	LT1	LT2	LT3_1	LT3_2	Functional Configuration
1	SSF-SCF	SSF	SCF	SRF	Sig con A	Sig con B	A
2	SSF-SCF	SSF	SCF	-	Sig con A	Sig con B	B
3	SCF-SCF	SCF	SSF	SCF	Sig con A	Sig con B	C

## 4.3 Test of SSF-SCF interface using INAP

The test program contains the program of the main LT1 main tester as well as the co-ordination points to co-ordinate the tasks with the other testers LT2 and LT3.

**IUT:** is the SSF-INAP.

**LT1:** test program is the SCF.

**LT2:** test program is the SRF-INAP when required.

**LT3:** informal test program for actions and observation at the signalling control points, to play the role of end users A, B and C for instance.

There are as many LT3 as required by the test configuration (LT3\_1, LT3\_2, ..) according to the number of end users A, B and C involved in a service scenario for instance, using different types of protocols).

- Pm:** contains the protocols used below the INAP between SCP and SSP, also between SSP and SRF. They could be e.g. TCAP, SCCP and MTP of SS7 etc.
- Pn:** contains the protocols used below the LT3\_1 between the IUT and the Signalling control point. It could be the DSS1 protocols or ISUP SS7 protocol (in the case of having a transit exchange).
- Pz:** contains the used protocols below the LT3\_2 between the IUT and the Signalling control point. It could be the DSS1 protocols or ISUP SS7 protocol (in the case of having a transit exchange).

## 4.4 Test of SCF-SCF interface using INAP

The test program contains the program of the main LT1 main tester as well as the co-ordination points to co-ordinate the tasks with the other testers LT2 and LT3.

**IUT:** is the SCF-INAP under test.

**LT1:** test program is the SSF.

**LT2:** test program is the Second SCF.

**LT3:** informal test program for actions and observation at the signalling control points, to play the role of end users A, B and C for instance.

There are as many LT3 as required by the test configuration (LT3\_1, LT3\_2, ..) according to the number of end users A, B and C involved in a service scenario for instance, using different types of protocols).

- Pm:** contains the protocols used below the INAP between SCP and SSP, also between SSP and SRF. They could be e.g. TCAP, SCCP and MTP of SS7 etc.
- Pn:** contains the protocols used below the LT3\_1 between the IUT and the Signalling control point. It could be the DSS1 protocols or ISUP SS7 protocol (in the case of having a transit exchange).
- Pz:** contains the used protocols below the LT3\_2 between the IUT and the Signalling control point. It could be the DSS1 protocols or ISUP SS7 protocol (in the case of having a transit exchange).

## 4.5 Points of control and observation (PCOs)

PCO-Declarations.

- PCO\_1:** This PCO is at the core INAP interface between SSP and SCP. The lower layer protocol is Pm. It could be e.g. TCAP.
- PCO\_2:** This PCO is at the core INAP interface between SSP and SRF. The lower layer protocol is Pm. It could be e.g. TCAP, ISUP, B-ISUP, TUP or the NWK of DSS1.
- PCO\_3\_1:** This PCO is at the interface between SSP and Signalling Control A. The lower layer protocol is Pn. It could be e.g. ISUP, B-ISUP, TUP or the NWK of DSS1.
- PCO\_3\_2:** This PCO is at the interface between SSP and Signalling Control B. The lower layer protocol is Pz. It could be e.g. ISUP, B-ISUP, TUP or the NWK of DSS1.

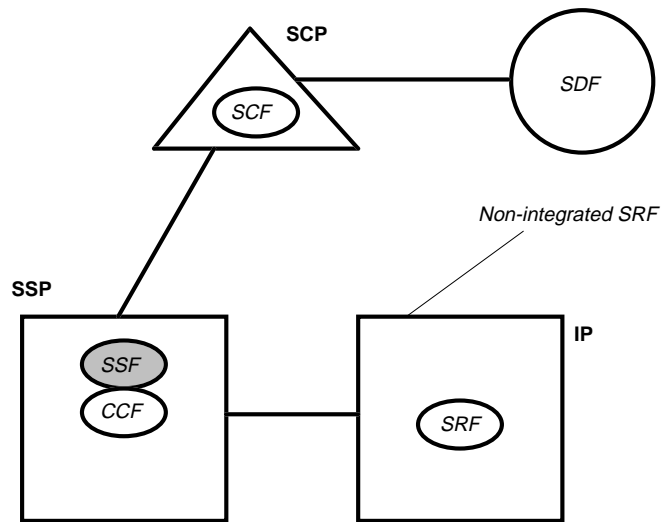
## 4.6 Test system

It is expected that the test system supports the protocols Pm, Pm-1, Pm-2 and the protocols for Pn and Pz.

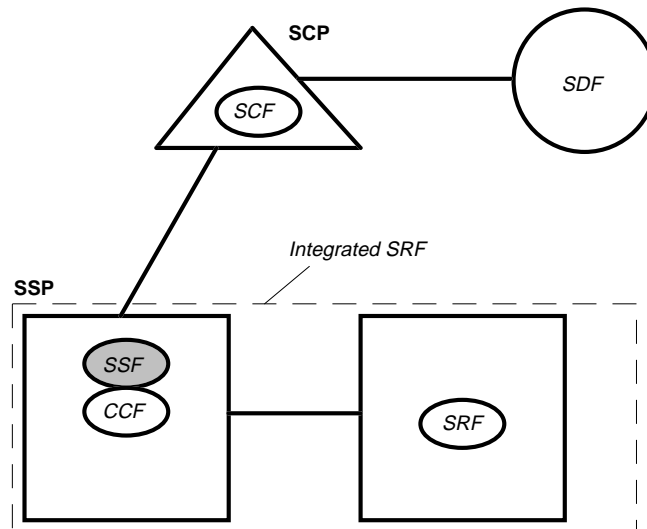
It is expected that the test system supports the PCO Requirements of PCO\_1, PCO\_2, PCO\_3\_1 and PCO\_3\_n.

## 4.7 Functional configurations

### 4.7.1 SSF-SCF interface

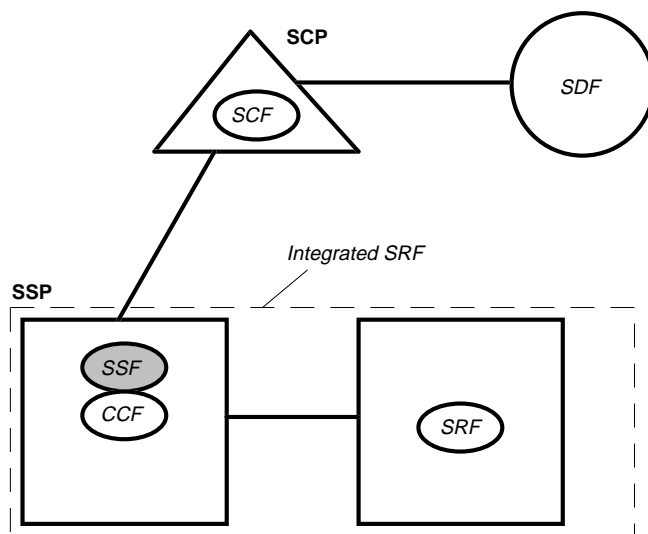


**Figure 2: SCP with single SSP**  
**Configuration A: IUT = SSF (non integrated with SRF)**



**Figure 3: SCP with single SSP**  
**Configuration B: IUT = SSF (integrated with SRF)**

### 4.7.2 SCF-SCF interface



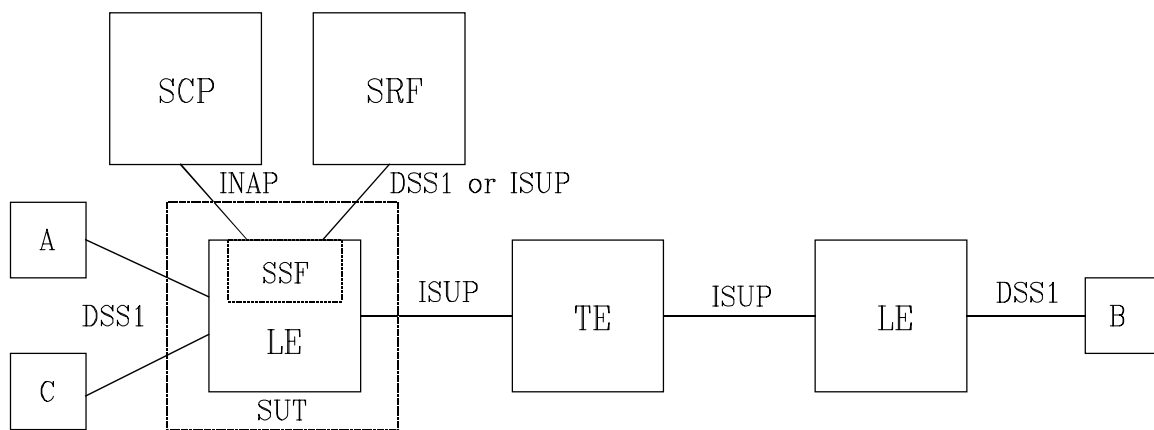
**Figure 4: SCP to SCP  
Configuration C: IUT = SCF**

**Figure 5: Void**

**Figure 6: Void**

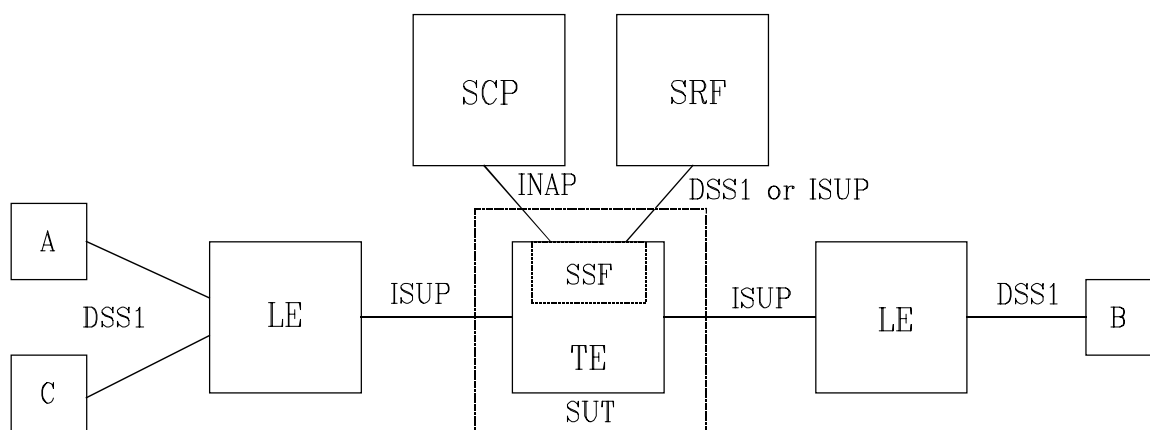
### 4.7.3 Reference to product implementation

The SUT can either be a Local Exchange (LE) or a Transit Exchange (TE). The exact number of testers (LT3 alone or LT3\_1 and LT3\_2) will depend upon the type of exchange and the configuration of the exchange, as explained by the following examples of implementation.



**Figure 7: Configuration with Local Exchange as SUT**

Figure 7 shows a configuration where the SUT is a Local Exchange. In this case, signalling of a call may be done either with DSS1 and ISUP (A and B involved) or only with DSS1 (A and C involved).



**Figure 8: Configuration with Transit Exchange as SUT**

Figure 8 shows a configuration where the SUT is a Transit Exchange. In this case, signalling uses ISUP protocol only.

## 4.8 Protocol primitives

### 4.8.1 Protocol primitives at PCO\_1 and PCO\_2

The transmission of INAP messages at the interface between SCF and SSF or SSF and SRF uses TCAP primitives. The LT1, LT2 communicate with the lower protocols via the SAPs with the TCAP-primitives shown in tables 2 and 3 according to clause 10 of ETS 300 374-1 [2] and ITU-T Recommendation Q.771 [3] of ITU-T.

**Table 2**

Primitives for dialogue handling	
Abstract Service Primitive	Type
TC_BEGIN	Request or Indication
TC_CONTINUE	Request or Indication
TC_END	Request or Indication
TC_U_ABORTa	Request or Indication
TC_U_ABORTb	Request or Indication
TC_P_ABORTa	Indication
TC_P_ABORTb	Indication
TC-NOTICE	Indication

**Table 3**

Primitives for components handling	
Abstract Service Primitive	Type
TC_INVOKE	Request or Indication
TC_U_ERROR	Request or Indication
TC_U_REJECT	Request or Indication
TC_L_REJECT	Indication
TC_R_REJECT	Indication
TC_U_CANCEL	Request or Indication

TCAP is included in the SDL model of CS2 INAP.

## 4.8.2 Protocol primitives at PCO\_3\_1 and PCO\_3\_2

In order to be protocol independent, a set of primitives is defined at this interface, and the next table is an example of the mapping between this generic interface and the possible signalling protocols like ISUP and DSS1.

Here follows the list of these primitives for the generic interface and a table giving the mapping of the generic primitives into real protocols.

**Table 4**

Mapping table for the interface between SSP and signalling control point				
PCO_3-1 or 3-2 interface primitives	Type	if ISUP used	if DSS1 used	if other protocols used
Setup	Indication	IAM	Setup	?
	Request			
	Response Confirm	ANM	Answer	
Release	Request Indication	REL/RLC	Disconnect	?
SubsequentAddress	Request Indication	SAM	Information	?
AddressEnd	Request Indication	SAM	Information	?
CallProgress	Request Indication	ACM, CPG	Progress, Alerting	?
ServiceFeature	Request Indication	?	Facility ?	?
NetworkSuspend	Request Indication	SUSPEND	--	?
NetworkResume	Request Indication	RESUME	--	?

## 5 ATS conventions

**This clause describes the conventions applied to define the ATS and gives the naming conventions chosen for the different elements of the ATS.**

The ATS conventions are intended to give a better understanding of the ATS but they describe also the conventions made for the development of the ATS, thus for any later maintenance purposes or further development of the ATS, the conventions described in this clause shall be considered.

### 5.1 Naming conventions

#### 5.1.1 Declarations part

This subclause describes the naming conventions chosen for the elements of the ATS declarations part.

##### 5.1.1.1 Test suite type and structured type definitions By Reference

In order to avoid misalignment problems with the standard, all the types used in this ATS have been defined by reference. The same ASN.1 files containing the standard type definitions have been used as modules containing the referenced type definitions.

EXAMPLE:      Type Name            Type Reference            Module Identifier  
                   CallResult        CallResult                INCS2datatypes

Where an abbreviation is included in the declaration name, there is an underscore ("\_") before and/or after it, separating it from the rest of the identifier. This rule with abbreviations applies to all the naming conventions in the whole test suite.

### 5.1.1.2 Test suite operations definitions

The test suite operation identifiers are composed of strings in uppercase letters starting with the uppercase string "TSO\_". The different strings in the definition are separated with underscores.

### 5.1.1.3 Test suite parameter declarations

The test suite parameter identifiers are composed of strings in uppercase letters starting by the uppercase string "PIC\_" or "PIX\_" and separated by underscores.

If the test suite parameter references a PICS item, the prefix "PIC\_" is used.

If the test suite parameter references a PIXIT item, the prefix "PIX\_" is used.

EXAMPLE:     PIX\_CalledPartyNumber1

Complete names as defined in the specifications are used.

### 5.1.1.4 Test case selection expression definitions

The naming conventions for the test case selection expression definitions use free text starting with an uppercase letter. The name of the expression is intended to explain clearly the selection rule. The test case selection expressions are generally logical combinations of the test suite parameter definitions.

### 5.1.1.5 Test suite constant declarations By Reference

In order to avoid misalignment problems with the standard, all the constants used in this ATS have been defined by reference. The same ASN.1 files containing the standard constant definitions have been used as modules containing the referenced type definitions.

EXAMPLE:	ConstantName	Type	ModuleIdentifier
	leg1	OCTET_STRING	INCS2SSFSCFopsargs

Complete names as defined in the specifications are used. However, in the parameters including a dot character, the dot is replaced by an underscore.

### 5.1.1.6 Test suite variable declarations

The test suite variable identifiers are composed of string in lowercase letters starting with the lowercase string "tsv\_".

EXAMPLE:     tsv\_DialogId

If the test suite variable represents a system parameter or value, the name defined in the specifications is used. However, in the variables including a dot character, the dot is replaced by an underscore.

### 5.1.1.7 Test case variable declarations

The test case variable identifiers are composed of strings in lowercase letters starting by the lowercase string "tcv\_".

EXAMPLE:     tcv\_

### 5.1.1.8 Timer declarations

Two kinds of timers are distinguished:

- 1) standardized:

Those defined in the standard, e.g. T\_ssf, use the same name as in the standard, beginning with a capital "T", except that the dot is replaced by an underscore.

As there is a tolerance margin accepted for these timers, two values are needed:

- the maximum value allowed, which uses the suffix "\_Max";
- the minimum value allowed, which uses the suffix "\_Min".

EXAMPLE 1: T\_ssf\_Min, T\_ssf\_Max

2) non-standardized:

Those not defined in the standard, i.e. for execution use, e.g. a timer waiting for a response. These timers begin with the prefix "T\_", followed by a string in lowercase letters with each word in the following string starting with an uppercase letter.

EXAMPLE 2: T\_Response

T\_NoResponse

### 5.1.1.9 ASP type definitions

ASP definitions follow the specification when a corresponding definition exists. If not, a free text name is used.

EXAMPLE: TC\_BeginInd

### 5.1.1.10 Alias definitions

No alias definitions are used in the test suite.

## 5.1.2 Constraints part

This subclause describes the naming conventions chosen for the elements of the ATS constraints part.

Constraint identifiers commence with uppercase.

**Table 5**

Type Definition	Constraint Definition Example
TC_InvokeInd(IDP)	CII_InitialDp
TC_InvokeReq(RNC)	CIR_RequestNotificationCharging
TC_ErrorInd	C_TC_ErrorIndparameterOutOfRange
TC_ErrorReq	C_TC_ErrorReq
TC_BeginInd(/Req)	C_TC_BeginInd(/Req)
TC_ContinueInd(/Req)	C_TC_ContinueInd(/Req)
TC_EndInd(/Req)Basic	C_TC_EndInd(/Req)Basic
TC_EndReqPrearranged	C_TC_EndReqPrearranged
TC-AbortInd	C_TC_AbortInd

### 5.1.3 Dynamic part

This subclause describes the naming conventions chosen for the elements of the ATS dynamic part.



### 5.1.3.1 Test case identifier

The identifier of a Test Case (TC) is identical to the corresponding Test Purpose, as described in table 6:

**Table 6: TC naming convention**

Identifier:	<b>IN2_&lt;i&gt;_&lt;sss&gt;_&lt;pp&gt;_&lt;cc&gt;_&lt;nn&gt;</b>										
IN2	indicates IN Capability Set 1 and 2 (CS-1 being in CS-2)										
<i>	=	interface:	<table> <tr> <td>A</td> <td>SSF-SCF interface</td> </tr> <tr> <td>B</td> <td>SSF-SRF interface</td> </tr> <tr> <td>C</td> <td>SCF-SCF interface</td> </tr> </table>	A	SSF-SCF interface	B	SSF-SRF interface	C	SCF-SCF interface		
A	SSF-SCF interface										
B	SSF-SRF interface										
C	SCF-SCF interface										
<sss>	=	common set	<table> <tr> <td>BASIC</td> <td>Basic set for CS-1 complemented for CS-2</td> </tr> <tr> <td>CPH</td> <td>from Capability Set 2</td> </tr> <tr> <td>CTM</td> <td>from Capability Set 2</td> </tr> </table>	BASIC	Basic set for CS-1 complemented for CS-2	CPH	from Capability Set 2	CTM	from Capability Set 2		
BASIC	Basic set for CS-1 complemented for CS-2										
CPH	from Capability Set 2										
CTM	from Capability Set 2										
<pp>	=	procedure name such as	<table> <tr> <td>SF</td> <td>ServiceFiltering</td> </tr> </table>	SF	ServiceFiltering						
SF	ServiceFiltering										
<cc>	=	test category:	<table> <tr> <td>CA</td> <td>Capability tests</td> </tr> <tr> <td>BV</td> <td>Valid Behaviour tests</td> </tr> <tr> <td>BI</td> <td>Invalid Behaviour tests</td> </tr> <tr> <td>BO</td> <td>Inopportune Behaviour tests</td> </tr> </table>	CA	Capability tests	BV	Valid Behaviour tests	BI	Invalid Behaviour tests	BO	Inopportune Behaviour tests
CA	Capability tests										
BV	Valid Behaviour tests										
BI	Invalid Behaviour tests										
BO	Inopportune Behaviour tests										
<nn>	=	sequential number:	(01-99)								
Example of test case name: <b>IN2_A_BASIC_SF_BV_02</b>											

### 5.1.3.2 Test step identifier

The test step identifier refers to a set of TTCN statement used within the test body of a test case. Different names can be used according the test step's purpose.

### 5.1.3.3 Preamble identifier

A preamble defines a set of TTCN statements needed to carry the IUT to a particular state or a particular call configuration situation (Call Party Handling) from which the test case starts. Different names are chosen for the preambles according the rules presented within the Test Purposes documentation.

### 5.1.3.4 Postamble identifier

A postamble defines a set of TTCN statements needed to end the test case in a properly way. Different names are chosen for the postambles according the rules presented within the Test Purposes documentation.

### 5.1.3.5 Default identifier

A default is a set of TTCN statements used to complete the behaviour tree related to the test case. It covers some different alternatives bringing the test case to a FAIL or INCONCLUSIVE verdict.

---

## 6 Implementation conventions

Fully functional underlying TCAP protocol is assumed from the test system.

Fully Functional underlying MTP-3/ISDN protocol is assumed from the test system.

### 6.1 TC and TP mapping

There is a one-to-one mapping between the TC identifiers and the TP identifiers.

---

## 7 ATS generalities

### 7.1 ATS design

This ATS has been produced according to methodology based on the use of formal languages (SDL, ASN.1, TTCN). Starting from the protocol description and using a powerful software environment, the TTCN test cases were generated according to the test purpose description.

#### 7.1.1 Methodology

The methodology that has been used to produce the ATS tries to integrate the specification of a protocol and the definition of the conformance testing related to that protocol. Several stages integrating the whole process of testing and specification can be identified. In each stage a different formal language applies. Figure 9 shows the different steps followed to achieve the ATS generation.

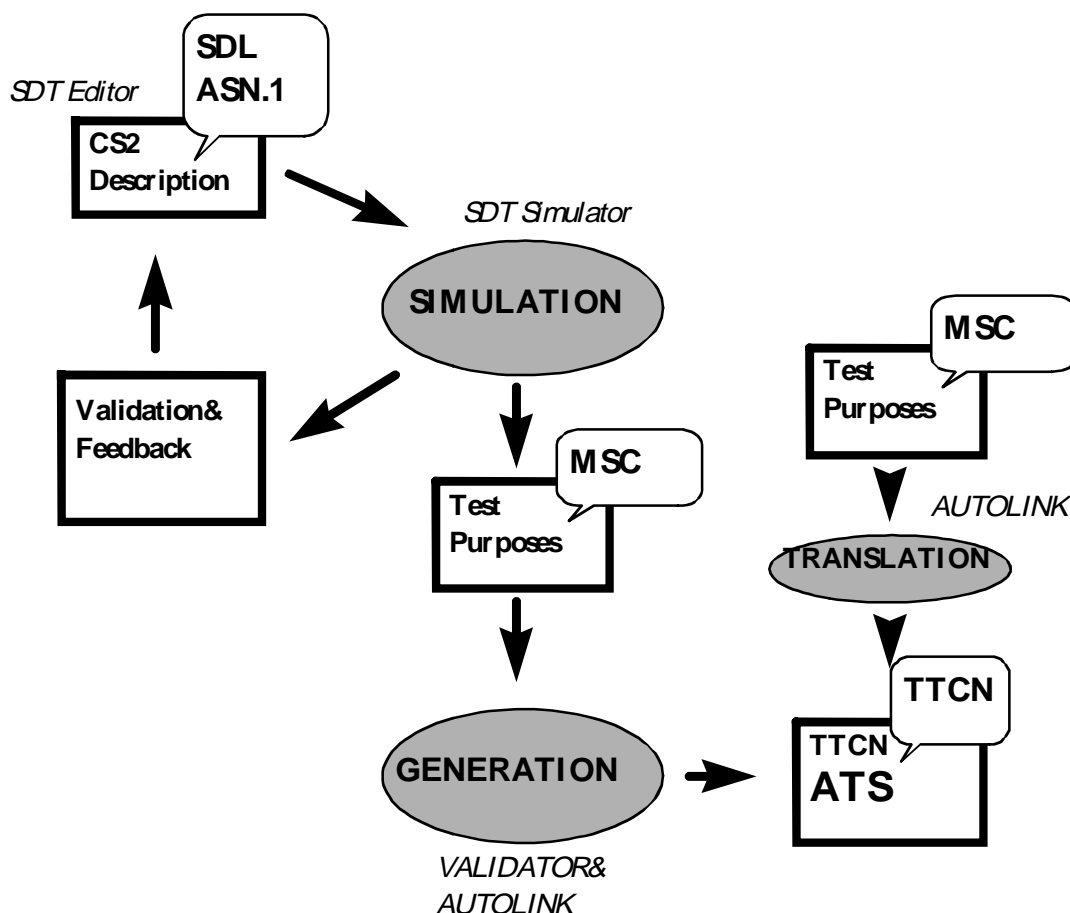


Figure 9: Steps in the generation of the ATS

- **SIMULATION**

The SDL formal description of the INAP CS2 is taken as an input for this stage. The formal description of the protocol includes not only the SDL model but ASN.1 type definitions. A former simulation of the model allows improvement of the SDL system description (Validation & Feedback). Once the model is validated, it is possible to simulate the test purposes against the model; for each simulated test purpose a MSC is obtained. These MSCs show the message exchange between the different interfaces involved in the description of the test purpose.

- **GENERATION**

The MSCs obtained from the model simulation are used in this stage to generate the TTCN test cases. Using the SDL INAP CS2 model and the MSCs (obtained from simulation) as inputs, the complete ATS is generated.

- **TRANSLATION**

As the SDL model does not include the whole protocol specification, some MSCs must be defined manually to complement those obtained from the model simulation. The error handling and some operator specific procedures description are not included in the model. The MSCs designed by hand were translated to TTCN test cases using the Autolink™ tool (integrating the SDT environment).

## 7.2 Test Configuration

When the IUT is considered to be an SSP the signalling protocol interaction should be taken into account. Some of the INAP CS2 operations have influence on the signalling scheme. The coordination of the message sequences on the different signalling interface is performed using a TTCN concurrent test configuration. Figure 10 shows the test configuration; test components, LTs, PCOs, etc. adopted for the CS1 (subset of CS2) test definition.

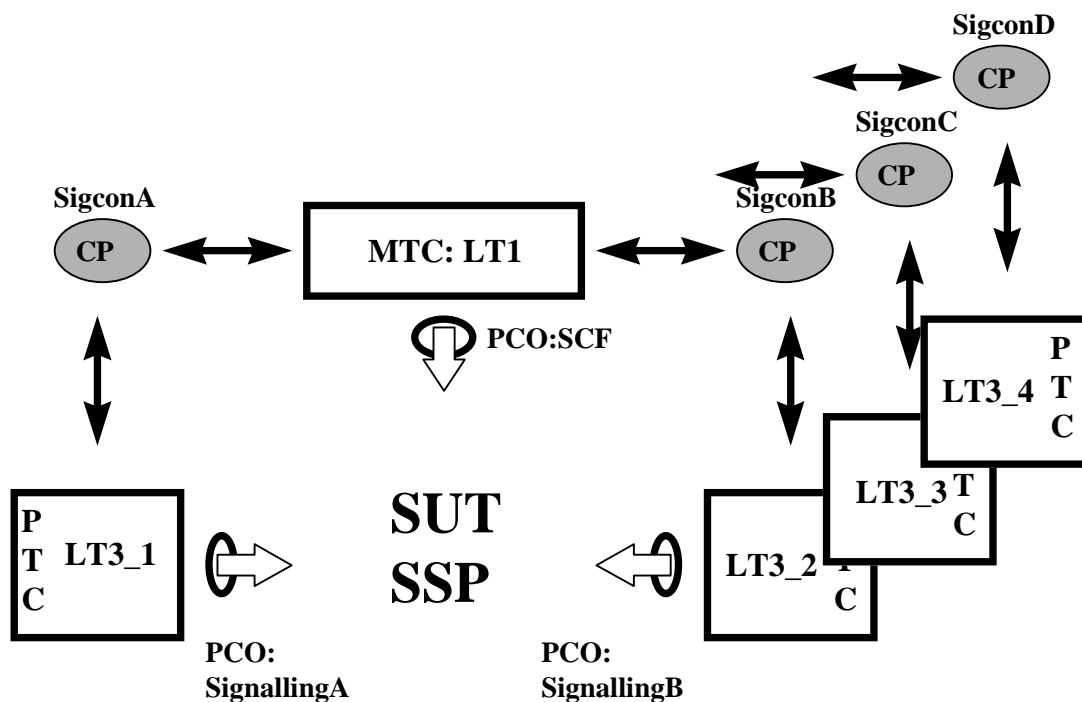


Figure 10

Each time a test case starts from the Master Test Component (MTC) some different behaviour trees are started at the corresponding PTCs (Parallel Test Component). The trees running at the PTC's control the signalling interfaces between the test device and the SUT (System Under Test). In order to co-ordinate the behaviour between the INAP interface and the signalling interfaces (SignallingA, SignallingB,...) the MTC uses some co-ordination messages through CPs (Co-ordination Point).

### 7.2.1 Example

The abstract signalling primitives used in the SDL model to reflect the Call Control Functionality of the SSP become co-ordination messages between the MTC and the several PTCs. A mapping between the abstract signalling primitives and the real signalling messages is done at the PTCs. As the real signalling procedures are operator dependent, no parallel behaviour trees are included in the ATS. An example of how to introduce the parallel signalling behaviour trees is shown in figure 11:

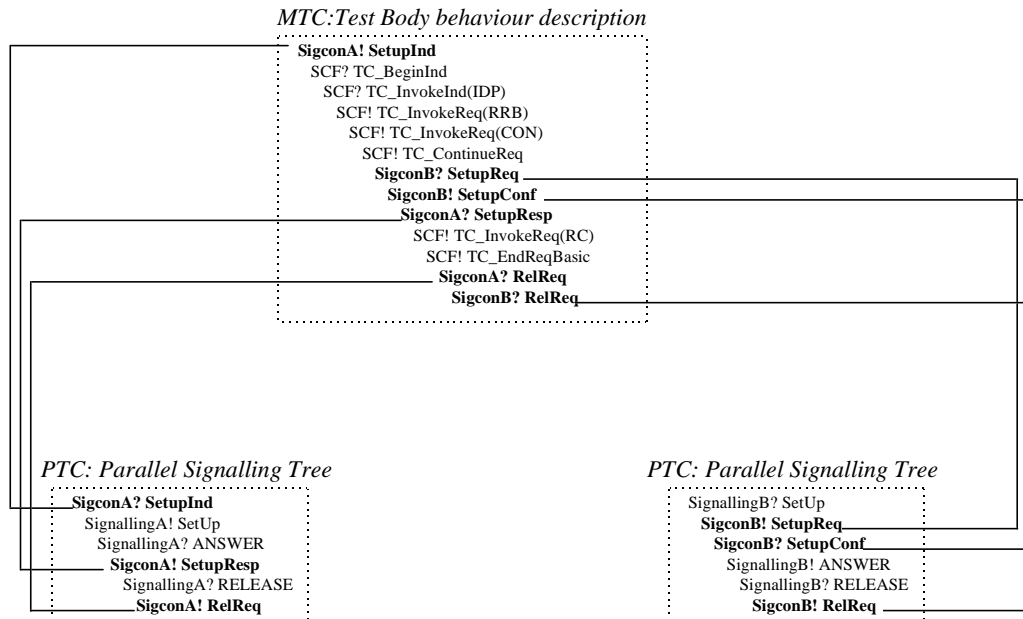


Figure 11

Figure 11 shows a full co-ordination between the INAP interface and the signalling interfaces being done from the MTC test body. The test case takes into account not only the INAP procedures but the signalling procedures.

### 7.3 ATS restrictions.

- 1) The Abstract Test Suite generated using Autolink™ introduces the ASN.1 type definitions By Reference. All the ASN.1 type definitions are included in several ASN.1 files associated to the ATS. If the ATS user wants to compile the TTCN test cases, either he should ask for a compiling facility to compile type definitions by reference or he should try to have a flat ATS with normal ASN.1 type definitions (cut and Paste between the ATS and the files containing the ASN.1 type definitions).
- 2) The test cases have been generated automatically from the MSCs, and by so doing, they check for all the possible sequence orders within the test body.
- 3) The constraint definitions have been generated automatically, and this explains their identifiers.
- 4) No Select Expressions have been included in the ATS. As default all the test cases are selected for the test campaign.
- 5) For those test cases which use a T\_BCSM based preamble, the following DPs need to be armed as TDPs before the start of the test case: analysedInformation on leg 1 on an O\_BCSM and termAttemptAuthorized on leg 1 for a T\_BCSM.

---

## Annex A (normative): ATS for CS1 INAP (subset of the INAP CS2)

This ATS has been produced using the Tree and Tabular Combined Notation (TTCN) according to ISO/IEC 9646-3 [6].

The ATS was developed on a separate TTCN software tool and therefore the TTCN tables are not completely referenced in the table of contents. The ATS itself contains a test suite overview part which provides additional information and references.

---

### A.1 The TTCN Graphical form (TTCN.GR)

The TTCN.GR representation of this ATS is contained in an Adobe Portable Document Format™ file (inap\_cs1\_v5.PDF contained in archive ak109idc.ZIP) which accompanies the present document.

---

### A.2 The TTCN Machine Processable form (TTCN.MP)

The TTCN.MP representation corresponding to this ATS is contained in an ASCII file (inap\_cs1\_v5.MP contained in archive ak109idc.ZIP) which accompanies the present document.

NOTE: According to ISO/IEC 9646-3 [6], in case of a conflict in interpretation of the operational semantics of TTCN.GR and TTCN.MP, the operational semantics of the TTCN.GR representation takes precedence.

---

## Annex B (normative): Partial PIXIT proforma for INAP CS1 layer

Notwithstanding the provisions of the copyright clause related to the text of the present document, ETSI grants that users of the present document may freely reproduce the PIXIT proforma in this annex so that it can be used for its intended purposes and may further publish the completed PIXIT.

The PIXIT proforma is based on ISO/IEC 9646-6 [8]. Any additional information needed can be found in this international standard document.

---

### B.1 Identification summary

**Table B.1**

PIXIT number:	
Test laboratory name:	
Date of issue:	
Issued to:	

---

### B.2 ATS summary

**Table B.2**

Protocol specification:	EN 301 140-1
Protocol to be tested:	
ATS specification:	EN 301 140-4-1
Abstract test method:	Remote test method, embedded variant

---

### B.3 Test laboratory

**Table B.3**

Test laboratory identification:	
Test laboratory manager:	
Means of testing:	
SAP address:	

---

### B.4 Client identification

**Table B.4**

Client identification:	
Client test manager:	
Test facilities required:	

## B.5 SUT

Table B.5

Name:	
Version:	
SCS number:	
Machine configuration:	
Operating system identification:	
IUT identification:	
PICS reference for IUT:	
Limitations of the SUT:	
Environmental conditions:	

## B.6 Protocol layer information

### B.6.1 Protocol identification

Table B.6

Name:	EN 301 140-1
Version:	
PICS references:	EN 301 140-2

### B.6.2 IUT information

#### B.6.2.1 Implicit send events

Table B.7 Implicit send events

Item	PIXIT (See note)	Related implicit send message (PDU)	Invocation description
1			
2			
3			
4			
5			
6			
7			
8			
9			
10			
11			
12			
13			
14			
15			
16			

NOTE: The PIXIT names for the implicit send events in this table are the same as those of the test steps in which the implicit send events are used.



## B.6.2.2 Core INAP Parameter values

Table B.8 Parameter values

Item	Parameter	Parameter type	Explanation/Format	Value
	PIX_AChBillingChargingCharacteristics	AChBillingChargingCharacteristics	"xx"H	
	PIX_AlertingPattern	AlertingPattern	"xxx"H	
	PIX_AlertingPattern_ICA	AlertingPattern	"xxx"H	
	PIX_APTyAbandonCause	Cause	"xx"H	
	PIX_APTyDiscCause	Cause	"xx"H	
	PIX_AssistingSSPIRoutingAddress	AssistingSSPIRoutingAddress	"xxxx"H	
	PIX_BPTyBusy_UDUBCause	Cause	"xx"H	
	PIX_BPTyNoAnswerCause	Cause	"xx"H	
	PIX_CalledPartyNumber1_CON	CalledPartyNumber	LegId 2 "xxxx"H	
	PIX_CalledPartyNumber2_CON	CalledPartyNumber	LegId 3 "xxxx"H	
	PIX_CalledPartyNumber3_CON	CalledPartyNumber	LegId 4 "xxxx"H	
	PIX_CalledPartyNumber4_CON	CalledPartyNumber	LegId 5 "xxxx"H	
	PIX_CalledPartyNumber5_CON	CalledPartyNumber	LegId 6 "xxxx"H	
	PIX_CalledPartyNumber6_CON	CalledPartyNumber	LegId 7 "xxxx"H	
	PIX_CalledPartyNumber7_CON	CalledPartyNumber	LegId 8 "xxxx"H	
	PIX_CalledPartyNumber8_CON	CalledPartyNumber	LegId 9 "xxxx"H	
	PIX_CalledPartyNumberInvalid_CON	CalledPartyNumber	"xxxx"H	
	PIX_CalledPartyNumber1_ICA	CalledPartyNumber	LegId 2 "xxxx"H	
	PIX_CalledPartyNumber2_ICA	CalledPartyNumber	LegId 3 "xxxx"H	
	PIX_CalledPartyNumber3_ICA	CalledPartyNumber	LegId 4 "xxxx"H	
	PIX_CalledPartyNumber4_ICA	CalledPartyNumber	LegId 5 "xxxx"H	
	PIX_CalledPartyNumber5_ICA	CalledPartyNumber	LegId 6 "xxxx"H	
	PIX_CalledPartyNumber6_ICA	CalledPartyNumber	LegId 7 "xxxx"H	
	PIX_CalledPartyNumber7_ICA	CalledPartyNumber	LegId 8 "xxxx"H	
	PIX_CalledPartyNumber1_SetupInd	CalledPartyNumber	"xxxx"H	
	PIX_CalledPartyNumber2_SetupInd	CalledPartyNumber	"xxxx"H	
	PIX_CallingPartyNumber1	CallingPartyNumber	"xxxx"H	
	PIX_CallingPartyNumber2	CallingPartyNumber	"xxxx"H	
	PIX_CallingPartysCategory_CON	CallingPartysCategory	"xx"H	
	PIX_CallingPartysCategory_SetupInd	CallingPartysCategory	"xx"H	
	PIX_DateAndTime	DateAndTime	YYMMDDHHMMSS	
	PIX_Duration	Duration	Seconds	
	PIX_EventTypeCharging1	EventTypeCharging		
	PIX_EventTypeCharging2	EventTypeCharging		
	PIX_FCIBillingChargingCharacteristics	FCIBillingChargingCharacteristics		
	PIX_InbandInfo_message	InbandInfo	InformationToSend	
	PIX_Interval	Integer	Seconds	
	PIX_IPRoutingAddress	IPRoutingAddress	"xx"H	
	PIX_LocationNumber	LocationNumber	"xxx"H	
	PIX_MaximumNumberOfCounters	MaximumNumberOfCounters	"xx"H	
	PIX_NumberOfCalls	Integer	xx	
	PIX_OriginalCalledPartyNumber	CalledPartyNumber	"xxxx"H	
	PIX_RedirectingPartyNumber	CalledPartyNumber	"xxxx"H	
	PIX_RedirectionInformation	RedirectionInformation	"xx"H	
	PIX_ReleaseCause	Cause	"xx"H	
	PIX_RouteSelectFailure1Cause	Cause	"xx"H	
	PIX_RouteSelectFailure2Cause	Cause	"xx"H	
	PIX_ScflD	ScflD	"xxxx"H	
	PIX_ServiceInteractionIndicators	ServiceInteractionIndicators	"xx"H	
	PIX_ServiceKey1	ServiceKey	"xx"H	
	PIX_ServiceKey2	ServiceKey	"xx"H	
	PIX_SFBillingChargingCharacteristics	SFBillingChargingCharacteristics	"xxxx"H	
	PIX_StartTime	DateAndTime	YYMMDDHHMMSS	
	PIX_StopTime	DateAndTime	YYMMDDHHMMSS	

Item	Parameter	Parameter type	Explanation/Format	Value
	PIX_ElementaryMessageID	integer	xxx	
	PIX_CorrelationId	correlationID	"xxx"H	
	PIX_UiScriptID1	integer	xxx	
	PIX_UiScriptID2	integer	xxx	
	PIX_UiScriptIDInvalid	integer	xxx	
	PIX_UiScriptResult	UiScriptResult	"xxxx"H	
	PIX_UiScriptSpecificInfo	UiScriptSpecificInfo	"xxxx"H	

### B.6.2.3 TCAP Parameter values

**Table B.9 Parameter values**

Item	Parameter	Parameter type	Explanation	Value
	PIX_Invokeld	InvokeldType	Direction SCF ->SSF Direction SSF->SCF	
	PIX_DialogueId	DialogueIDType	Direction SCF ->SSF Direction SSF->SCF	

## Annex C (normative): Protocol Conformance Test Report (PCTR) proforma for CORE INAP CS1 protocol layer

Notwithstanding the provisions of the copyright clause related to the text of the present document, ETSI grants that users of the present document may freely reproduce the PCTR proforma in this annex so that it can be used for its intended purposes and may further publish the completed PCTR.

The PCTR Proforma is based on ISO/IEC 9646-6 [8]. Any additional information needed can be found in the present document.

### C.1 Identification summary

#### C.1.1 Protocol conformance test report

**Table C.1**

PCTR number:	
PCTR date:	
Corresponding SCTR number:	
Corresponding SCTR date:	
Test laboratory identification:	
Test laboratory manager:	
Signature:	

#### C.1.2 IUT identification

**Table C.2**

Name:	
Version:	
Protocol specification:	
PICS:	
Previous PCTR if any:	

#### C.1.3 Testing environment

**Table C.3**

PIXIT number:	
ATS specification:	
Abstract test method:	
Means of testing identification:	
Date of testing:	
Conformance log reference(s):	
Retention date for log reference(s):	

### C.1.4 Limits and reservation

Additional information relevant to the technical contents or further use of the test report, or the rights and obligations of the test laboratory and the client, may be given here. Such information may include restriction on the publication of the report.

.....  
.....  
.....  
.....  
.....

### C.1.5 Comments

Additional comments may be given by either the client or the test laboratory on any of the contents of the PCTR, for example, to note disagreement between the two parties.

.....  
.....  
.....  
.....  
.....

---

## C.2 IUT conformance status

This IUT has or has not been shown by conformance assessment to be non-conforming to the specified protocol specification.

Strike the appropriate words in this sentence. If the PICS for this IUT is consistent with the static conformance requirements as specified in clause C.3 in this report and there are no "FAIL" verdicts to be recorded in clause C.6 strike the words "has or". otherwise strike the words "or has not".

---

## C.3 Static conformance summary

The PICS for this IUT is or is not consistent with the static conformance requirements in the specified protocol.

Strike the appropriate words in this sentence.

---

## C.4 Dynamic conformance summary

The test campaign did or did not reveal errors in the IUT.

Strike the appropriate words in this sentence. If there are no "FAIL" verdicts to be recorded in clause C.6 of this report strike the words "did or" otherwise strike the words "or did not".

Summary of the results of groups of test:

.....  
.....  
.....  
.....

---

## C.5 Static conformance review report

If clause C.3 indicates non-conformance, this subclause itemizes the mismatches between the PICS and the static conformance requirements of the specified protocol specification.

.....

.....

.....

.....

.....

.....

.....

.....

.....

.....

.....

.....

## C.6 Test campaign report

Table C.4

ATS reference	Selected	Run	Verdict	Observations (see note)
SF				
IN2_A_BASIC_SF_CA_01	Yes/No	Yes/No		
IN2_A_BASIC_SF_BV_01	Yes/No	Yes/No		
IN2_A_BASIC_SF_BV_02	Yes/No	Yes/No		
IN2_A_BASIC_SF_BV_03	Yes/No	Yes/No		
IN2_A_BASIC_SF_BI_01	Yes/No	Yes/No		
IN2_A_BASIC_SF_BI_02	Yes/No	Yes/No		
IN2_A_BASIC_SF_BO_01	Yes/No	Yes/No		
IN2_A_BASIC_SF_BO_02	Yes/No	Yes/No		
AT				
IN2_A_BASIC_AT_CA_01	Yes/No	Yes/No		
IN2_A_BASIC_AT_BV_01	Yes/No	Yes/No		
IN2_A_BASIC_AT_BV_02	Yes/No	Yes/No		
IN2_A_BASIC_AT_BI_01	Yes/No	Yes/No		
AC				
IN2_A_BASIC_AC_CA_01	Yes/No	Yes/No		
IN2_A_BASIC_AC_BV_01	Yes/No	Yes/No		
IN2_A_BASIC_AC_BV_02	Yes/No	Yes/No		
IN2_A_BASIC_AC_BV_03	Yes/No	Yes/No		
IN2_A_BASIC_AC_BV_04	Yes/No	Yes/No		
IN2_A_BASIC_AC_BI_01	Yes/No	Yes/No		
IN2_A_BASIC_AC_BI_02	Yes/No	Yes/No		
IN2_A_BASIC_AC_BO_01	Yes/No	Yes/No		
CG				
IN2_A_BASIC_CG_CA_01	Yes/No	Yes/No		
IN2_A_BASIC_CG_BV_01	Yes/No	Yes/No		
IN2_A_BASIC_CG_BV_02	Yes/No	Yes/No		
IN2_A_BASIC_CG_BV_03	Yes/No	Yes/No		
IN2_A_BASIC_CG_BV_04	Yes/No	Yes/No		
IN2_A_BASIC_CG_BV_05	Yes/No	Yes/No		
IN2_A_BASIC_CG_BV_06	Yes/No	Yes/No		
IN2_A_BASIC_CG_BV_07	Yes/No	Yes/No		
IN2_A_BASIC_CG_BV_08	Yes/No	Yes/No		
IN2_A_BASIC_CG_BV_09	Yes/No	Yes/No		
IN2_A_BASIC_CG_BV_10	Yes/No	Yes/No		
IN2_A_BASIC_CG_BI_01	Yes/No	Yes/No		
CF				
IN2_A_BASIC_CF_CA_01	Yes/No	Yes/No		
IN2_A_BASIC_CF_BV_01	Yes/No	Yes/No		
IN2_A_BASIC_CF_BV_02	Yes/No	Yes/No		
IN2_A_BASIC_CF_BV_03	Yes/No	Yes/No		
IN2_A_BASIC_CF_BV_04	Yes/No	Yes/No		
IN2_A_BASIC_CF_BV_05	Yes/No	Yes/No		
IN2_A_BASIC_CF_BI_01	Yes/No	Yes/No		
IN2_A_BASIC_CF_BO_01	Yes/No	Yes/No		
IN2_A_BASIC_CF_BO_02	Yes/No	Yes/No		
CA				
IN2_A_BASIC_CA_CA_01	Yes/No	Yes/No		
(CA_BV_01 was dropped)				
IN2_A_BASIC_CA_BV_02	Yes/No	Yes/No		
IN2_A_BASIC_CA_BV_03	Yes/No	Yes/No		
IN2_A_BASIC_CA_BV_04	Yes/No	Yes/No		
IN2_A_BASIC_CA_BI_01	Yes/No	Yes/No		
IN2_A_BASIC_CA_BO_01	Yes/No	Yes/No		
CI				
IN2_A_BASIC_CI_CA_01	Yes/No	Yes/No		
IN2_A_BASIC_CI_BI_01	Yes/No	Yes/No		

ATS reference	Selected	Run	Verdict	Observations (see note)
IN2_A_BASIC_CI_BO_01	Yes/No	Yes/No		
IN2_A_BASIC_CI_BO_02	Yes/No	Yes/No		
IN2_A_BASIC_CI_BO_03	Yes/No	Yes/No		
CO				
IN2_A_BASIC_CO_CA_01	Yes/No	Yes/No		
IN2_A_BASIC_CO_BV_01	Yes/No	Yes/No		
IN2_A_BASIC_CO_BV_02	Yes/No	Yes/No		
IN2_A_BASIC_CO_BV_03	Yes/No	Yes/No		
IN2_A_BASIC_CO_BV_04	Yes/No	Yes/No		
IN2_A_BASIC_CO_BV_05	Yes/No	Yes/No		
IN2_A_BASIC_CO_BV_06	Yes/No	Yes/No		
IN2_A_BASIC_CO_BV_07	Yes/No	Yes/No		
IN2_A_BASIC_CO_BV_08	Yes/No	Yes/No		
IN2_A_BASIC_CO_BV_09	Yes/No	Yes/No		
IN2_A_BASIC_CO_BI_01	Yes/No	Yes/No		
IN2_A_BASIC_CO_BO_01	Yes/No	Yes/No		
CU				
IN2_A_BASIC_CU_CA_01	Yes/No	Yes/No		
IN2_A_BASIC_CU_BV_01	Yes/No	Yes/No		
FC				
IN2_A_BASIC_FC_CA_01	Yes/No	Yes/No		
IN2_A_BASIC_FC_BV_01	Yes/No	Yes/No		
DP				
IN2_A_BASIC_DP_CA_01	Yes/No	Yes/No		
IN2_A_BASIC_DP_CA_02	Yes/No	Yes/No		
IN2_A_BASIC_DP_BV_01	Yes/No	Yes/No		
IN2_A_BASIC_DP_BV_02	Yes/No	Yes/No		
IN2_A_BASIC_DP_BV_03	Yes/No	Yes/No		
IN2_A_BASIC_DP_BV_04	Yes/No	Yes/No		
IN2_A_BASIC_DP_BV_05	Yes/No	Yes/No		
IN2_A_BASIC_DP_BI_01	Yes/No	Yes/No		
IN2_A_BASIC_DP_BI_02	Yes/No	Yes/No		
IC				
IN2_A_BASIC_IC_CA_01	Yes/No	Yes/No		
IN2_A_BASIC_IC_BV_01	Yes/No	Yes/No		
IN2_A_BASIC_IC_BV_02	Yes/No	Yes/No		
IN2_A_BASIC_IC_BO_01	Yes/No	Yes/No		
IN2_A_BASIC_IC_BO_02	Yes/No	Yes/No		
RC				
IN2_A_BASIC_RC_CA_01	Yes/No	Yes/No		
IN2_A_BASIC_RC_BV_01	Yes/No	Yes/No		
RC_BV_02 was dropped	Yes/No	Yes/No		
RC_BV_03 was dropped	Yes/No	Yes/No		
IN2_A_BASIC_RC_BV_04	Yes/No	Yes/No		
IN2_A_BASIC_RC_BO_01	Yes/No	Yes/No		
RR				
IN2_A_BASIC_RR_CA_01	Yes/No	Yes/No		
IN2_A_BASIC_RR_BV_01	Yes/No	Yes/No		
IN2_A_BASIC_RR_BV_02	Yes/No	Yes/No		
IN2_A_BASIC_RR_BV_03	Yes/No	Yes/No		
IN2_A_BASIC_RR_BV_04	Yes/No	Yes/No		
IN2_A_BASIC_RR_BV_05	Yes/No	Yes/No		
IN2_A_BASIC_RR_BV_06	Yes/No	Yes/No		
IN2_A_BASIC_RR_BV_07	Yes/No	Yes/No		
IN2_A_BASIC_RR_BV_08	Yes/No	Yes/No		
IN2_A_BASIC_RR_BV_09	Yes/No	Yes/No		
IN2_A_BASIC_RR_BV_10	Yes/No	Yes/No		
IN2_A_BASIC_RR_BV_11	Yes/No	Yes/No		
IN2_A_BASIC_RR_BV_12	Yes/No	Yes/No		
IN2_A_BASIC_RR_BV_13	Yes/No	Yes/No		
IN2_A_BASIC_RR_BV_14	Yes/No	Yes/No		
IN2_A_BASIC_RR_BV_15	Yes/No	Yes/No		
RR_BV_16 was dropped	Yes/No	Yes/No		

ATS reference	Selected	Run	Verdict	Observations (see note)
IN2_A_BASIC_RR_BV_17	Yes/No	Yes/No		
IN2_A_BASIC_RR_BV_18	Yes/No	Yes/No		
IN2_A_BASIC_RR_BV_19	Yes/No	Yes/No		
IN2_A_BASIC_RR_BV_20	Yes/No	Yes/No		
IN2_A_BASIC_RR_BV_21	Yes/No	Yes/No		
IN2_A_BASIC_RR_BV_22	Yes/No	Yes/No		
IN2_A_BASIC_RR_BV_23	Yes/No	Yes/No		
IN2_A_BASIC_RR_BV_24	Yes/No	Yes/No		
IN2_A_BASIC_RR_BV_25	Yes/No	Yes/No		
IN2_A_BASIC_RR_BV_26	Yes/No	Yes/No		
IN2_A_BASIC_RR_BV_27	Yes/No	Yes/No		
IN2_A_BASIC_RR_BV_28	Yes/No	Yes/No		
IN2_A_BASIC_RR_BV_29	Yes/No	Yes/No		
IN2_A_BASIC_RR_BV_30	Yes/No	Yes/No		
IN2_A_BASIC_RR_BV_31	Yes/No	Yes/No		
IN2_A_BASIC_RR_BV_32	Yes/No	Yes/No		
IN2_A_BASIC_RR_BV_33	Yes/No	Yes/No		
IN2_A_BASIC_RR_BV_34	Yes/No	Yes/No		
IN2_A_BASIC_RR_BI_01	Yes/No	Yes/No		
IN2_A_BASIC_RR_BI_02	Yes/No	Yes/No		
IN2_A_BASIC_RR_BO_01	Yes/No	Yes/No		
RN				
IN2_A_BASIC_RN_CA_01	Yes/No	Yes/No		
IN2_A_BASIC_RN_BV_01	Yes/No	Yes/No		
IN2_A_BASIC_RN_BV_02	Yes/No	Yes/No		
IN2_A_BASIC_RN_BI_01	Yes/No	Yes/No		
IN2_A_BASIC_RN_BO_01	Yes/No	Yes/No		
NOTE: Reference to any observations made in clause C.7 in this report.				

## C.7 Observations

Additional information relevant to the technical content of the PCTR are given here.

.....

.....

.....

.....

.....

.....

.....

.....

.....

.....



---

## History

<b>Document history</b>		
26/03/1998	V03	distributed to SPS3 meeting, Edimburg
V1.1.2	June 1999	Public Enquiry PE 9947: 1999-06-23 to 1999-11-19