

Draft **EN 301 113** V6.1.0 (1998-07)

European Standard (Telecommunications series)

**Digital cellular telecommunications system (Phase 2+);
General Packet Radio Service (GPRS);
Service description;
Stage 1
(GSM 02.60 version 6.1.0 Release 1997)**



GSM®
GLOBAL SYSTEM FOR
MOBILE COMMUNICATIONS

ETSI 

Reference

DEN/SMG-010260Q6 (ab0030c0.PDF)

Keywords

Digital cellular telecommunications system,
Global System for Mobile communications (GSM)

ETSI

Postal address

F-06921 Sophia Antipolis Cedex - FRANCE

Office address

650 Route des Lucioles - Sophia Antipolis
Valbonne - FRANCE
Tel.: +33 4 92 94 42 00 Fax: +33 4 93 65 47 16
Siret N° 348 623 562 00017 - NAF 742 C
Association à but non lucratif enregistrée à la
Sous-Préfecture de Grasse (06) N° 7803/88

Internet

secretariat@etsi.fr
<http://www.etsi.fr>
<http://www.etsi.org>

Copyright Notification

No part may be reproduced except as authorized by written permission.
The copyright and the foregoing restriction extend to reproduction in all media.

© European Telecommunications Standards Institute 1998.
All rights reserved.

Contents

Intellectual Property Rights.....	5
Foreword	5
1 Scope.....	6
2 Normative references	7
3 Definitions and abbreviations	8
3.1 Definitions	8
3.2 Abbreviations.....	13
4 Applicability.....	13
5 Description.....	14
5.1 GPRS reference model.....	14
5.1.1 Bearer services	15
5.1.2 Teleservices.....	15
5.1.3 GPRS Access Points.....	16
5.2 GPRS service description	16
5.2.1 Point-To-Point Connectionless Network Service (PTP-CLNS).....	17
5.2.2 Point-To-Point Connection Orientated Network Service (PTP-CONS).....	17
5.3 Transfer Characteristics	17
5.4 Service characteristics.....	18
5.4.1 Subscriber profile	18
5.4.2 Quality of Service (QoS).....	18
5.4.2.1 QoS parameter definitions	19
5.4.2.1.1 Service precedence (priority).....	19
5.4.2.1.2 Reliability	19
5.4.2.1.3 Delay	19
5.4.2.1.4 Throughput	20
5.4.2.2 QoS profile	20
5.4.2.3 Monitor.....	20
5.4.3 Security services.....	21
5.4.4 Packet size.....	21
5.4.5 Capabilities of GPRS MS Classes.....	21
5.4.6 Subscriber roaming	22
5.4.7 Construction of GPRS subscriber numbers	22
5.4.8 Battery life extension.....	22
5.4.9 Format Of Message User Data	23
5.4.10 Charging aspects	23
5.4.10.1 PTP charging information.....	23
5.4.10.2 Reverse Charging.....	23
5.4.11 Message Screening.....	23
6 Normal procedures with successful outcome.....	23
6.1 Provision	23
6.2 Withdrawal	24
6.3 GPRS-Attach, GPRS-Detach	24
6.4 Registration.....	24
6.5 Erasure	25
6.6 Interrogation	25
6.7 Activation	25
6.8 De-activation.....	26
6.9 Invocation and operation	26
6.10 PIN and Password Management	26
7 Exceptional procedures.....	26
7.1 Provision	26
7.2 Withdrawal	26

7.3	Registration.....	27
7.4	Erasure.....	27
7.5	Interrogation.....	27
7.6	Activation.....	27
7.7	De-activation.....	27
7.8	Invocation and operation.....	27
7.9	PIN and Password management.....	27
8	Addressing.....	27
10	Service interworking.....	28
11	Network interworking.....	28
11.1	Interworking with other data networks and other PLMNs.....	28
11.1.1	QoS when Interworking.....	29
11.2	GPRS Numbering Plan.....	29
11.3	Addressing and routeing requirements.....	29
11.4	Interworking for subscriber roaming.....	29
Annex A (Informative):	Change history.....	30
History.....		31

Intellectual Property Rights

IPRs essential or potentially essential to the present document may have been declared to ETSI. The information pertaining to these essential IPRs, if any, is publicly available for **ETSI members and non-members**, and can be found in ETR 314: "*Intellectual Property Rights (IPRs); Essential, or potentially Essential, IPRs notified to ETSI in respect of ETSI standards*", which is available **free of charge** from the ETSI Secretariat. Latest updates are available on the ETSI Web server (<http://www.etsi.fr/ipr>).

Pursuant to the ETSI Interim IPR Policy, no investigation, including IPR searches, has been carried out by ETSI. No guarantee can be given as to the existence of other IPRs not referenced in ETR 314 (or the updates on <http://www.etsi.fr/ipr>) which are, or may be, or may become, essential to the present document.

Foreword

This European Standard (Telecommunications series) has been produced by ETSI Special Mobile Group (SMG), and is now submitted for the ETSI standards One-step Approval Procedure.

In analogy with CCITT Recommendations I.130, the first stage of the following three level structure is used to describe the telecommunications services as provided by European public telecommunications operators:

- | | |
|---------|---|
| Stage 1 | is an overall service description, from the service subscriber's and user's standpoint; |
| Stage 2 | identifies the functional capabilities and information flows needed to support the service described in stage 1; and |
| Stage 3 | defines the signalling system protocols and switching functions needed to implement the service described in stage 1. |

This EN details the stage 1 aspects (overall service description) for the General Packet Radio Service (GPRS) on Global System for Mobile communications (GSM) networks.

The contents of this EN are subject to continuing work within SMG and may change following formal SMG approval. Should SMG modify the contents of this EN it will then be re-submitted for OAP with an identifying change of release date and an increase in version number as follows:

Version 6.x.y

where:

- 6 indicates GSM Release 1997 of Phase 2+
- x the second digit is incremented for all other types of changes, i.e. technical enhancements, corrections, updates, etc.
- y the third digit is incremented when editorial only changes have been incorporated in the specification;

1 Scope

This EN defines the stage one description of the General Packet Radio Service (GPRS) on Global System for Mobile communications (GSM) networks. Stage one is an overall service description, primarily from the service subscriber's and user's points of view, but does not deal with the details of the human interface itself. This EN includes information applicable to network operators, service providers and terminal, switch and data base manufacturers.

This EN contains the core requirements for the GPRS on GSM, which are sufficient to provide a complete service.

This EN also documents some additional requirements which may be implemented (but do not have to be implemented).

In addition, additional functionalities not documented in this EN may be implemented. The requirements of which are considered outside the scope of this EN and consequently outside the scope of the corresponding stage 2 and stage 3 specifications. This additional functionality may be on a network-wide basis, or particular to one or a group of users. Such additional functionality shall not compromise conformance to the core requirements of the service.

The interface between the Mobile Station (MS) and any external applications are outside the scope of this EN.

Charging principles are outside the scope of this EN, unless specific service requirements are stated. These requirements deal with the allocation of certain call charges to particular users.

A later phase of GPRS may include interworking with circuit switched networks (e.g. PSTN, ISDN) and may emulate certain circuit switched services. These aspects are outside the scope of this version of this EN.

NOTE: This specification includes requirements for GPRS phase 1 (Rel '97). The first phase of standards specified will provide a basic functional GPRS service.

Phase 1 GPRS supports:

- PTP
- User Interworking for PTP TCP/IP.
- X.28 from MS to GGSN; X.25 from GGSN to external PDNs.

Internal Network Interfaces:

- **Gn** - GSN backbone network
- **Gb** - BSS to SGSN
- **Gr** - SGSN to HLR
- **Gp** - PLMN to PLMN (ie roaming)
- **Gs** - SGSN to MSC
- External Reference point **Gi** for connecting via **TCP/IP** and **X.25**
- Identities
- Security Issues - for PTP and roaming
- Charging Issues
- Operator Call Barring and Termination, Operator Call Screening
- PTM radio interface in preparation for phase 2.
- Anonymous access
- Support of SMS-MO and -MT via GPRS (note: SMS-CB not supported in phase 1).

2 Normative references

References may be made to:

- a) specific versions of publications (identified by date of publication, edition number, version number, etc.), in which case, subsequent revisions to the referenced document do not apply; or
- b) all versions up to and including the identified version (identified by "up to and including" before the version identity); or
- c) all versions subsequent to and including the identified version (identified by "onwards" following the version identity); or
- d) publications without mention of a specific version, in which case the latest version applies.

A non-specific reference to an ETS shall also be taken to refer to later versions published as an EN with the same number.

- [1] GSM 02.01: "Digital cellular telecommunications system (Phase 2+); Principles of telecommunication services supported by a GSM Public Land Mobile Network (PLMN)".
- [2] GSM 04.02: "Digital cellular telecommunications system (Phase 2+); GSM Public Land Mobile Network (PLMN) access reference configuration".
- [3] ITU-T Recommendation X.25: "Interface between data terminal equipment (DTE) and data circuit-terminating equipment (DCE) for terminals operating in the packet mode and connected to public data networks by dedicated circuit".
- [4] ISO 8208: "Information processing systems - data communications - X.25 packet level protocol for data terminal equipment".
- [5] ISO 8348: "Information processing systems - data communications - network service definition".
- [6] ISO 8473: "Information technology - protocol for providing the connectionless mode network service".
- [7] ISO 8878: "Information processing systems - data communications - use of X.25 to provide the OSI connection-mode network service".
- [8] Internet STD 5:RFC 791: Internet protocol, RFC 950: "Internet standard subnetting procedure", RFC 919: "Broadcasting internet datagrams", RFC 922: "Broadcasting internet datagrams in the presence of subnets", RFC 792: "Internet control message protocol", RFC 1112: "Host extensions for IP multicasting" RFC 1122:" Requirements for Internet hosts - communication layers". RFC 1920:" Internet official protocol standards", RFC 1458: "Requirements for multicast protocols", RFC 1301: "Multicast transport protocol".
- [9] ITU-T Recommendation X.3: "Packet Assembly/Disassembly facility (PAD) in a public data network".
- [10] ITU-T Recommendation X.28: "DTE/DCE interface for a start-stop mode Data Terminal Equipment accessing the Packet Assembly/Disassembly facility (PAD) in a public data network situated in the same country".
X.28 Add. 1 (7/94) Addendum 1 to Recommendation X.28 to enable MAP support in accordance with Recommendation X.8.
- [11] ITU-T Recommendation X.29: "Procedures for the exchange of control information and user data between a Packet Assembly/Disassembly (PAD) facility and a packet mode DTE or another PAD".
- [12] ITU-T Recommendation X.75: "Packet-switched signalling system between public networks providing data transmission services".
- [13] ITU-T Recommendation X.121: "International numbering plan for public data networks".

- [14] ITU-T Recommendation X.136: "Accuracy and dependability performance values for public data networks when providing international packet-switched services".
- [15] ITU-T Recommendation X.137: "Availability performance values for public data networks when providing international packet-switched services".
- [16] GSM 02.68: "Digital cellular telecommunications system (Phase 2+); Voice Group Call Service (VGCS) - Stage 1".
- [17] GSM 02.06: "Digital cellular telecommunications system (Phase 2+); Types of Mobile Stations (MS)".
- [18] GSM 02.04: "Digital cellular telecommunications system (Phase 2+); General on supplementary services".
- [19] GSM 02.30: "Digital cellular telecommunications system (Phase 2+); Man-Machine Interface (MMI) of the Mobile Station (MS)".
- [20] GSM 02.17: "Digital cellular telecommunications system (Phase 2+); Subscriber Identity Modules (SIM) Functional characteristics".
- [21] GSM 03.68: "Digital cellular telecommunications system (Phase 2+); Voice Group Call Service (VGCS) - Stage 2".
- [22] GSM 04.68: "Digital cellular telecommunications system (Phase 2+); Group Call Control (GCC) protocol".

3 Definitions and abbreviations

3.1 Definitions

For the purposes of this EN the following definitions apply:

A

access delay: The value of elapsed time between an access request and a successful access (source: ITU-T X.140).

access protocol: a defined set of procedures that is adopted at an interface at a specified reference point between a user and a network to enable the user to employ the services and/or facilities of that network (source: ITU-T I.112).

accuracy: A performance criterion that describes the degree of correctness with which a function is performed. (The function may or may not be performed with the desired speed.) (source: ITU-T I.350).

B

basic service: The telecommunication services excluding the supplementary services (source: GSM 01.04).

bearer service: A type of telecommunication service that provides the capability for the transmission of signals between user-network interfaces (source: GSM 01.04, ITU-T I.112).

best effort service: A service model which provides minimal performance guarantees, allowing an unspecified variance in the measured performance criteria.

C

calling user: Entity which originates a call to the General Packet Radio Service (GPRS).

connectionless service: A service which allows the transfer of information among service users without the need for end-to-end call establishment procedures (source: ITU-T I.113).

connectionless-mode transfer:

"The terms 'message', 'datagram', 'transaction mode' and 'connection-free' have been used in the literature to describe variations on the same basic theme: the transmission of a unit of data in a single, self-contained operation without establishing, maintaining, and releasing a connection."

"(Connectionless-mode transmission) is the transmission of a single unit of data from a source service-access-point to one or more destination service-access-point(s) without establishing a connection. A connectionless-mode service allows an entity to initiate such a transmission by the performance of a single service access.

In contrast to a connection, an instance of the use of a connectionless-mode service does not have a clearly distinguishable lifetime. In addition, the connectionless-mode service, unless otherwise explicitly determined, has the following fundamental characteristics:

- a) no dynamic peer-to-peer agreement is involved in an instance of the service;
- b) all of the information required to deliver a unit of data (destination address, quality of service selection, options, etc.) is presented to the layer providing the connectionless-mode service, together with the user data to be transmitted, in a single service access. The layer providing the connectionless-mode service is not required to relate this access to any other service access.

As a result of these fundamental characteristics it may also be true that

- c) each unit of data transmitted is entirely self-contained and can be routed independently;
- d) copies of a unit of data can be transmitted to a number of destination addresses."

NOTE: **Connectionless-mode transfer** normally implies that the service a) does not provide confirmed delivery of SDUs, b) does not guarantee delivery of SDUs, c) does not guarantee maintenance of SDU sequencing and d) does not guarantee elimination of SDUs.

connection-mode transfer:

"A connection is an association established for the transfer of data between two or more peer-entities. This association is established between the peer-entities themselves and between each entity and the next lower layer. The ability to establish a connection and to transfer data over it is provided to the entities in a given layer by the next lower layer as a connection-mode service. An instance of the use of a connection-mode service by peer-entities proceeds through three distinct phases of operation:

- a) connection establishment;
- b) data transfer; and
- c) connection release."

NOTE: **Connection-mode transfer** normally implies that the service a) provides confirmed delivery of SDUs, b) provides ordered, in-sequence delivery of SDUs and c) will not duplicate SDUs.

conversational service: An interactive service which provides for bi-directional communication by means of real-time (no store-and-forward) end-to-end information transfer from user to user (source: ITU-T I.113).

D

demand service: A type of telecommunication service in which the communication path is established almost immediately, in response to a user request effected by means of user-network signalling (source: GSM 01.04, ITU-T I.112).

dependability: A performance criterion that describes the degree of certainty (or surety) with which a function is performed regardless of speed or accuracy, but within a given observational interval (source: ITU-T I.350).

destination user: Entity to which calls to the General Packet Radio Service (GPRS) are directed.

E

extra SDU delivery probability: The ratio of total (unrequested) extra service data units (SDUs) to total service data units received by a destination user in a specified sample (source: ITU-T X.140).

NOTE: the term "user information unit" has been replaced by the term "service data unit".

F

functional group: A set of functions that may be performed by a single equipment (source: ITU-T I.112).

G

guaranteed service: A service model which provides highly reliable performance, with little or no variance in the measured performance criteria.

I

interactive service: A service which provides the means for bi-directional exchange of information between users. Interactive services are divided into three classes of services: conversational services, messaging services and retrieval services (source: ITU-T I.113).

interface: The common boundary between two associated systems (source: GSM 01.04, ITU-T I.112).

M

mean bit rate: A measure of throughput. The average (mean) bit rate available to the user for the given period of time (source: ITU-T I.210).

mean transit delay: The average transit delay experienced by a (typically) large sample of PDUs within the same service category.

messaging service: An interactive service which offers user-to-user communication between individual users via storage units with store-and-forward, mailbox and/or message handling, (e.g., information editing, processing and conversion) functions (source: ITU-T I.113).

mobile station: Equipment intended to access a set of GSM PLMN telecommunication services. Services may be accessed while the equipment capable of surface movement within the GSM system area is in motion or during halts at unspecified points (source: GSM 01.04).

mobile termination: The part of the mobile station which terminates the radio transmission to and from the network and adapts terminal equipment capabilities to those of the radio transmission (source GSM 01.04).

N

network connection: An association established by a network layer between two users for the transfer of data, which provides explicit identification of a set of network data transmissions and agreement concerning the services to be provided by the set (source: ITU-T X.213 / ISO-IEC 8348).

network operator: Entity which provides the network operating elements and resources for the execution of the General Packet Radio Service (GPRS).

network service data unit (NSDU): A unit of data passed between the user and the GPRS network across a Network Service Access Point (NSAP).

network termination: A functional group on the network side of a user-network interface (source: ITU-T I.112).

P

packet: An information unit identified by a label at layer 3 of the OSI reference model (source: ITU-T I.113). A network protocol data unit (NPDU).

packet data protocol (PDP): Any protocol which transmits data as discrete units known as packets, e.g., IP, or X.25.

packet transfer mode: Also known as packet mode. A transfer mode in which the transmission and switching functions are achieved by packet oriented techniques, so as to dynamically share network transmission and switching resources between a multiplicity of connections (source: ITU-T I.113).

peak bit rate: A measure of throughput. The maximum bit rate offered to the user for a given time period (to be defined) for the transfer of a bursty signal (source: ITU-T I.210). (The maximum user information transfer rate achievable by a user for a single service data unit transfer.)

PLMN Operator: Public Land Mobile Network operator. The entity which offers a GPRS.

point-to-point (PTP): A value of the service attribute "communication configuration", which denotes that the communication involves only two network terminations.

point-to-point (PTP) service: A service type in which data is sent from a single network termination to another network termination.

predictive service: A service model which provides reliable performance, but allowing a specified variance in the measured performance criteria.

protocol: A formal set of procedures that are adopted to ensure communication between two or more functions within the within the same layer of a hierarchy of functions (source: ITU-T I.112).

protocol data unit (PDU): In the reference model for OSI, a unit of data specified in an (N)-protocol layer and consisting of (N)-protocol control information and possibly (N)-user data (source: ITU-T X.200 / ISO-IEC 7498-1).

Q

quality of service: The collective effect of service performances which determine the degree of satisfaction of a user of the service (ITU-T E.800). The set of performance parameters that can be directly observed and measured at the point at which the service is accessed by the user. There are three criteria by which performance is measured: speed, accuracy and dependability (source: ITU-T I.350).

R

reference configuration: A combination of functional groups and reference points that shows possible network arrangements (source: GSM 01.04, ITU-T I.112).

reference point: A conceptual point at the conjunction of two non-overlapping functional groups (source: GSM 01.04, ITU-T I.112).

residual error rate: A parameter describing service accuracy. The frequency of lost SDUs, and of corrupted or duplicated network SDUs delivered at the user-network interface.

retrieval service: An interactive service which provides the capability of accessing information stored in data base centres. The information will be sent to the user on demand only. The information is retrieved on an individual basis, i.e., the time at which an information sequence is to start is under the control of the user (source ITU-T I.113).

S

SDU error probability: The ratio of total incorrect service data units (SDUs) to total successfully transferred service data units plus incorrect service data units in a specified sample (source: ITU-T X.140).

NOTE: the source document term "user information unit" has been replaced by the term "service data unit".

SDU loss probability: The ratio of total lost service data units (SDUs) to total transmitted service data units in a specified sample (source: ITU-T X.140).

NOTE: the source document term "user information unit" has been replaced by the term "service data unit".

SDU misdelivery probability: The ratio of total misdelivered service data units (SDUs) to total service data units transferred between a specified source and destination user in a specified sample (source: ITU-T X.140).

NOTE: the source document term "user information unit" has been replaced by the term "service data unit".

SDU transfer delay: The value of elapsed time between the start of transfer and successful transfer of a specified service data unit (SDU) (source: ITU-T X.140).

NOTE: the source document term "user information unit" has been replaced by the term "service data unit".

SDU transfer rate: The total number of successfully transferred service data units (SDUs) in a transfer sample divided by the input/output time for that sample. The input/output time is the larger of the input time or the output time for the sample (source: ITU-T X.140).

NOTE: the source document term "user information unit" has been replaced by the term "service data unit".

service access point (SAP): In the reference model for OSI, the points through which services are offered to an adjacent higher layer (source: GSM 01.04, ITU-T X.200 / ISO-IEC 7498-1).

service attribute: A specified characteristic of a telecommunication service (source: ITU-T I.112).

NOTE: the value(s) assigned to one or more service attributes may be used to distinguish that telecommunications service from others.

service bit rate: The bit rate that is available to a user for the transfer of user information (source: ITU-T I.113).

service category or service class: A service offered to the users described by a set of performance parameters and their specified values, limits or ranges. The set of parameters provides a comprehensive description of the service capability.

service data unit (SDU): In the reference model for OSI, an amount of information whose identity is preserved when transferred between peer (N+1)-layer entities and which is not interpreted by the supporting (N)-layer entities (source: ITU-T X.200 / ISO-IEC 7498-1).

service delay: The time elapsed from the invocation of the service request, to the corresponding service request indication at the Service Receiver, indicating the arrival of application data.

service model: A general characterisation of services based upon a QoS paradigm, without specifying the actual performance targets.

service provider: Entity which offers the General Packet Radio Service (GPRS) for subscription. The network operator may be the service provider.

service receiver: The entity which receives the service request indication primitive, containing the SDU.

service request: This is defined as being one invocation of the service through a service request primitive.

service requester: The entity which requests the initiation of a GPRS operation, through a service request.

service subscriber: Entity which subscribes to the General Packet Radio Service (GPRS) service.

signalling: The exchange of information specifically concerned with the establishment and control of connections, and with management, in a telecommunications network (source: ITU-T I.112).

simultaneous use of services: The concurrent use of a GSM circuit-mode service (voice or data) and GSM packet-mode services (GPRS) by a single mobile station.

speed: A performance criterion that describes the time interval required to perform a function or the rate at which the function is performed. (The function may or may not be performed with the desired accuracy.) (source: ITU-T I.350).

T

teleaction service: A type of telecommunication service that uses short messages, requiring a low transmission rate, between the user and the network (source: ITU-T I.112).

telecommunication service: That which is offered by a PLMN operator or service provider to its customers in order to satisfy a specific telecommunication requirement. (source: GSM 01.04, ITU-T I.112). Telecommunication services are divided into two broad families: bearer services and teleservices (source: ITU-T I.210).

teleservice: A type of telecommunication service that provides the complete capability, including terminal equipment functions, for communication between users according to protocols established by agreement between Administrations (source: GSM 01.04, ITU-T I.112).

terminal equipment: Equipment that provides the functions necessary for the operation of the access protocols by the user (source: GSM 01.04). A functional group on the user side of a user-network interface (source: ITU-T I.112).

throughput: A parameter describing service speed. The number of data bits successfully transferred in one direction between specified reference points per unit time (source: ITU-T I.113).

transit delay: A parameter describing service speed. The time difference between the instant at which the first bit of a protocol data unit (PDU) crosses one designated boundary (reference point), and the instant at which the last bit of the PDU crosses a second designated boundary (source: ITU-T I.113).

U

user access or **user network access:** The means by which a user is connected to a telecommunication network in order to use the services and/or facilities of that network (source: GSM 01.04, ITU-T I.112).

user-network interface: The interface between the terminal equipment and a network termination at which interface the access protocols apply (source: ITU-T I.112).

user-user protocol: A protocol that is adopted between two or more users in order to ensure communication between them (source: ITU-T I.112).

V

variable bit rate service: A type of telecommunication service characterised by a service bit rate specified by statistically expressed parameters which allow the bit rate to vary within defined limits (source: ITU-T I.113).

3.2 Abbreviations

For the purposes of this EN the following definitions apply:

CLNP	Connectionless network protocol
CLNS	Connectionless network service
CONS	Connection-oriented network service
FFS	For further study
GPRS	General packet radio service
GSN	GPRS support node
IP	Internet protocol
NSDU	Network service data unit
PDP	Packet data protocol
PDU	Protocol data unit
PLMN	Public land mobile network
PTP	Point to point
QoS	Quality of service
SAP	Service access point
SVC	Switched virtual circuit
SDU	Service data unit
TBD	To be defined
TLLI	Temporary link level identity

Additional GSM related abbreviations can be found in GSM 01.04 (ETR 350) [1].

4 Applicability

The GPRS is a set of new GSM bearer services that provides packet mode transmission within the PLMN and interworks with external networks. It is not a requirement that the GPRS be an extension of or an emulation of one or any of these non-GSM services or networks.

The GPRS shall not prevent the user's operation of other GSM services.

5 Description

The GPRS allows the service subscriber to send and receive data in an end-to-end packet transfer mode, without utilizing network resources in circuit switched mode.

GPRS enables the cost effective and efficient use of network resources for packet mode data applications e.g. for applications that exhibit one or more of the following characteristics:

- intermittent, non-periodic (i.e., bursty) data transmissions, where the time between successive transmissions greatly exceeds the average transfer delay;
- frequent transmissions of small volumes of data, for example transactions consisting of less than 500 octets of data occurring at a rate of up to several transactions per minute;
- infrequent transmission of larger volumes of data, for example transactions consisting of several kilobytes of data occurring at a rate of up to several transactions per hour.

Within the GPRS, one bearer service type is defined. It is:

- Point-To-Point (PTP);

Based on standardized network protocols supported by the GPRS bearer services, a GPRS network administration may offer (or support) a set of additional services. This is outside the scope of this specification, however, a number of possible PTP interactive teleservices include:

- retrieval services which provide the capability of accessing information stored in data base centres. The information is sent to the user on demand only. An example of one such service in the Internet's World Wide Web (WWW);
- messaging services which offer user-to-user communication between individual users via storage units with store-and-forward mailbox, and/or message handling (e.g., information editing, processing and conversion) functions;
- conversational services which provide bi-directional communication by means of real-time (no store-and-forward) end-to-end information transfer from user to user. An example of such a service is the Internet's Telnet application;
- tele-action services which are characterized by low data-volume (short) transactions, for example credit card validations, lottery transactions, utility meter readings and electronic monitoring and surveillance systems.

5.1 GPRS reference model

The GPRS can be described using the simplified reference model in figure 1.

GPRS provides data transfer capabilities between a sending entity and one or more receiving entities. These entities may be an MS or a Terminal Equipment, the latter being attached either to a GPRS network or to an external data network. The base station provides radio channel access for MSs to the GPRS network. User data may be transferred between four types of MSs as described in GSM 02.01 [1] and GSM 04.02 [2]:

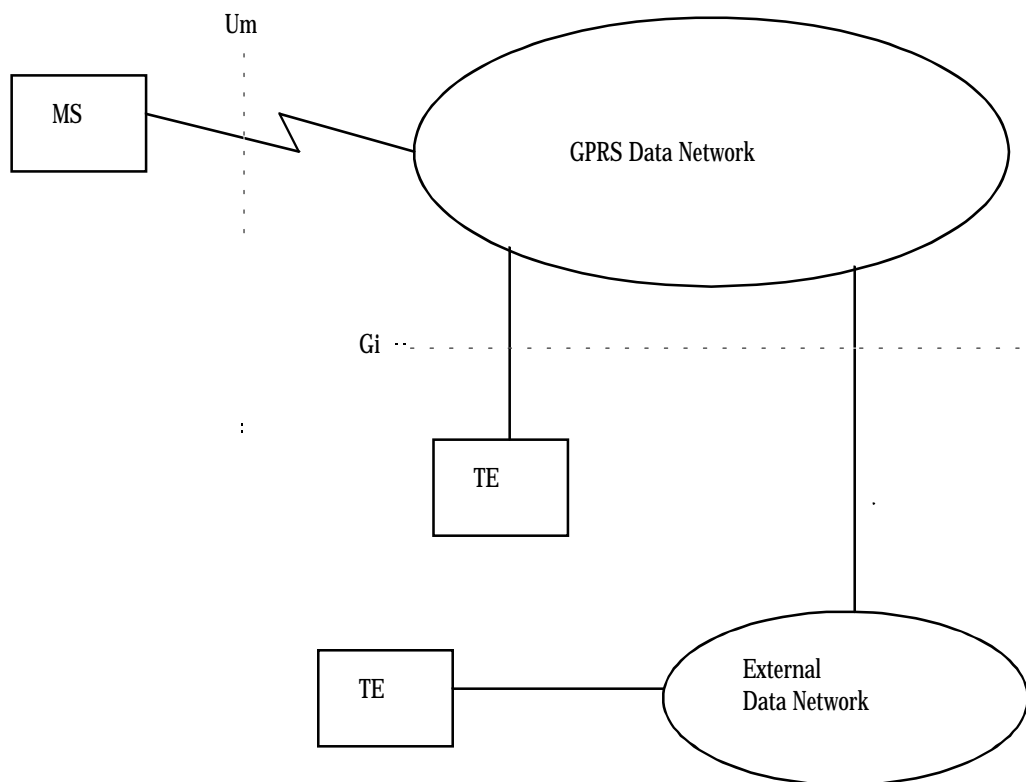

Figure 1: GPRS simplified reference model

5.1.1 Bearer services

The GPRS bearer services support the capability to transmit data between user-network access points (2, 4 and 7 in figure 2).

5.1.2 Teleservices

GPRS supports teleservices to provide complete communication service capabilities including the terminal equipment functions necessary for communication between network customers using the user-user protocols supported by the GPRS service provider(s) (see also GSM 02.01 [1]).

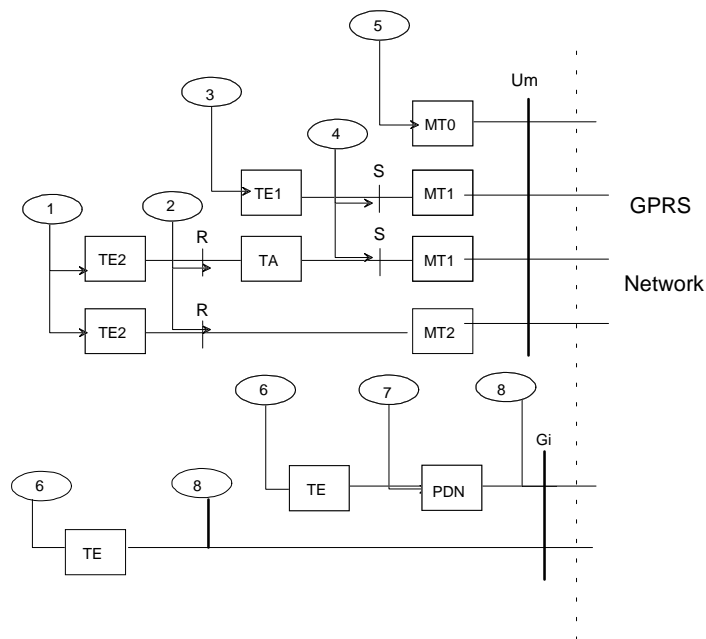

Figure 2: Telecommunication services access points

5.1.3 GPRS Access Points

Considering the reference configuration in figure 1, users can access various telecommunication services at different access points as shown in figure 2:

- at access points 1, 3, 5, and 6 (user-to-terminal interfaces), teleservices are accessed - the teleservice concept includes the terminal capabilities;
- at access point 2 (the R reference point), non-ISDN bearer services may be accessed, for example ITU-T X- and V-Series Recommendations;
- at access point 4 (the S reference point), ISDN compatible bearer services may be accessed;
- at access point 7 external data network bearer services may be accessed;
- access point 8 (the Gi reference point, which may not be identical for direct access and external data network access) provides bearer service access for direct access for a data terminal and/or for external data networks, for example X.25 networks.

5.2 GPRS service description

The PTP service provides a transmission of one or more packets between two users, initiated by a service requester and received by a receiver.

There are two PTP services:

- PTP Connectionless Network Service (PTP-CLNS);
- PTP Connection Orientated Network Service (PTP-CONS).

An invocation of the service request by a service requester is possible from the fixed and mobile access points. Invocation and operation procedures (i.e., parallel sessions) are described in subclause 6.9.

Table 1 presents the relationship between service requests and the Service Requester/Receiver.

Table 1: Relationship of service request and service requester/receiver

Service requester/receiver AP = Access Point (see note 1)	Types of service request			
	PTP-CONS and PTP-CLNS			
From fixed AP to mobile AP	Supported			
From mobile AP to mobile AP (see note 2)	Supported			
From mobile AP to fixed AP	Supported			
NOTE 1: Mobile bearer services access points are 2 and 4 from figure 2. Fixed bearer service access points are 7 and 8.				
NOTE 2: It shall be possible to transfer data between two mobiles of the same operator without the use of non-GSM external data networks.				

5.2.1 Point-To-Point Connectionless Network Service (PTP-CLNS)

Point-To-Point Connectionless Network Service (PTP-CLNS) is a service in which one (or more) single packet(s) is (are) sent from a single service subscriber "A" to a single destination user "B". Each packet is independent of the preceding and succeeding packet. This service is of the datagram type and is intended to support bursty applications. On the radio interface PTP-CLNS supports the acknowledged transfer mode for reliable delivery.

GPRS provides data communications services consistent with the connectionless network layer service definition ISO 8348 [5]. Specifically, GPRS shall be able to support applications based on the following network layer protocol:

- Internet Protocol (IP);
- IP is the network layer protocol of the Internet TCP/IP protocol suite defined by Internet STD 5 [8].

5.2.2 Point-To-Point Connection Orientated Network Service (PTP-CONS)

Point-To-Point Connection Orientated Network Service (PTP-CONS) is a service in which multiple packets are sent between a single service subscriber "A" and a single destination user "B". This service provides a logical relation between the users which may last between seconds to hours. The service is intended to support bursty transactive or interactive applications. On the radio interface PTP-CONS utilises the acknowledged transfer mode for reliable delivery.

GPRS provides data communications services consistent with the connection orientated network layer service definition ISO 8348 [5] and ISO 8878 [7]. This means that GPRS shall be able to support applications based on the following network layer protocol:

- Connection Orientated Network Protocol (CONP).
- CONP is the standard OSI connection orientated network protocol defined in ISO 8208 [4], i.e., the X.25 Packet Level Protocol for Data Terminal Equipment.

GPRS should provide the ability to maintain a connection orientated virtual circuit upon change of cell within a PLMN but not when transiting from one PLMN to another PLMN.

Any established SVC shall be released on irrecoverable failure of the radio data link.

5.3 Transfer Characteristics

The packet multiplexing mechanisms developed for GPRS shall be independent of a given channel type. It shall be possible to operate GPRS over low and high capacity channels. These may be existing and/or future channels whose capacities are as yet unspecified (e.g., a signalling channel, or two time-slots or an entire 200 kHz carrier). Table 3 is only applicable to the GPRS part of the connection.

Table 3: Transfer Characteristics

Attributes		Supported capabilities
Information Transfer Capability		Unrestricted digital information
Information Transfer Mode	Connection mode	Connection orientated, connectionless
	Traffic type ^(a)	Variable bit rate and variable delay
	Timing end-to-end ^(b)	Asynchronous
Information Transfer Rate ^(c)		Maximum bit rate. Values from one TCH (e.g. 9.6 kbit/s) up to eight TCH (e.g. 8x9.6 kbit/s) inclusive.
Information Structure		- Service data unit integrity - Data sequence integrity
Communication Configuration		- Point to point
Establishment of Communication ^(d)		Demand mobile originated or mobile terminated
Negotiation		- Out of band - In band
Symmetry		- Bi-directional - Unidirectional
Radio Channel assignment		Shared, multi-user

a) Traffic type: describing data streams with constant bit rate or variable bit rate characteristics.

b) Timing end-to-end: describing the timing relation between the source and destination of signals.

c) Flexible channels with a maximum bit rate that depends on the type of channel and the number of time slots that are used. This capability defines the maximum capability associated with the channel(s). The actual bit rate for a particular user may be any value up to this maximum value.

d) Establishment of communication: may be on demand, reserved or permanent.

5.4 Service characteristics

5.4.1 Subscriber profile

The subscriber profile holds subscription information about services and other parameters that have been assigned for an agreed contractual period. It includes the following information:

- subscribed services (PTP-CLNS, PTP-CONS);
- subscribed QoS profile (service precedence(priority), reliability, delay, throughput).

An invocation of a service by any user with the appropriate subscription profile shall be possible.

It shall be possible to validate a service request against a service subscriber's subscription profile.

5.4.2 Quality of Service (QoS)

The mapping of user application QoS parameters to GPRS QoS parameters is an implementation issue and is not part of GPRS specifications.

It shall be possible to respond to local data traffic conditions adaptively. GPRS shall include the functionality to increase or decrease the amount of radio resources allocated to GPRS on a dynamic basis. The criteria used to decide on dynamic changes of the GPRS part of the radio resource should not be specified. Thus, only the necessary procedure, including radio protocol and timers, needed to perform the change of radio resources shall be specified within the ETSI specifications.

Within GPRS the dynamic allocation of the radio resource for bursty or lengthy file transfer applications shall be such that it can be controlled by the network operator.

5.4.2.1 QoS parameter definitions

The defined QoS parameter values, assume the user is at a location with acceptable GSM-/GPRS-coverage and refer to and are valid for normal network operating conditions or, as in the case of the service precedence parameter, regulate how the network shall handle abnormal conditions.

5.4.2.1.1 Service precedence (priority)

The service precedence indicates the relative priority of maintaining the service. For example under abnormal conditions (e.g. network congestion) packets which may be discarded can be identified. The following precedence levels are defined:

- High precedence: Service commitments will be maintained ahead of all other precedence levels.
- Normal precedence: Service commitments will be maintained ahead of low priority users.
- Low precedence: Service commitments will be maintained after the high and normal priority commitments have been fulfilled.

5.4.2.1.2 Reliability

The reliability parameter indicates the transmission characteristics that are required by an application. The reliability class defines the probability of loss of, duplication of, mis-sequencing of or corruption of SDUs.

NOTE. If a user's application is based on X.25, which requires reliable delivery of X.25 SDUs, it would be incorrect for an application to use an reliability class with a high loss probability.

Table 4 lists the three classes of the data reliability.

Table 4: Reliability classes

Reliability class	Lost SDU probability (a)	Duplicate SDU probability	Out of Sequence SDU probability	Corrupt SDU probability (b)	Example of application characteristics.
1	10^{-9}	10^{-9}	10^{-9}	10^{-9}	Error sensitive, no error correction capability, limited error tolerance capability.
2	10^{-4}	10^{-5}	10^{-5}	10^{-6}	Error sensitive, limited error correction capability, good error tolerance capability.
3	10^{-2}	10^{-5}	10^{-5}	10^{-2}	Not error sensitive, error correction capability and/or very good error tolerance capability.

a) To protect against buffer overflow or a protocol malfunction, there is a maximum holding time for each SDU in the GPRS network after which the SDU is discarded. The maximum holding time depends on the protocols used (e.g., TCP/IP).

b) Corrupt SDU probability: the probability that a SDU will be delivered to the user with an undetected error.

5.4.2.1.3 Delay

GPRS is not a „store and forward“ service - although data is temporarily stored at network nodes during transmission - thus, any delay incurred is due to technical transmission characteristics (or limitations) of the system and is to be minimised for a particular delay class. The delay parameter thus defines the maximum values for the mean delay and 95-percentile delay to be incurred by the transfer of data through the GPRS network(s). The delay parameter defines the end-to-end transfer delay incurred in the transmission of SDUs through the GPRS network(s).

This includes the radio channel access delay (on uplink) or radio channel scheduling delay (on downlink), the radio channel transit delay (uplink and/or downlink paths) and the GPRS-network transit delay (multiple hops). It does not include transfer delays in external networks.

Delay is measured between the R or S (for MS) and Gi (for FS) reference points when applied to "MS to fixed station (FS)" or "FS to MS" transmissions.

Table 5: Delay classes

Delay Class	Delay (maximum values)			
	SDU size: 128 octets		SDU size: 1024 octets	
	Mean Transfer Delay (sec)	95 percentile Delay (sec)	Mean Transfer Delay (sec)	95 percentile Delay (sec)
1. (Predictive)	< 0.5	< 1.5	< 2	< 7
2. (Predictive)	< 5	< 25	< 15	< 75
3. (Predictive)	< 50	< 250	< 75	< 375
4. (Best Effort)	Unspecified			

5.4.2.1.4 Throughput

The throughput parameter indicates the user data throughput requested by the user.

Throughput is defined by two negotiable parameters:

- Maximum bit rate.
- Mean bit rate (includes, for example for "bursty" transmissions, the periods in which no data is transmitted.)

The maximum and mean bit rates can be negotiated to a value up to the Information Transfer Rate value (see table 3).

It shall be possible for the network to re-negotiate the throughput parameters at any time during a session.

5.4.2.2 QoS profile

The subscriber's QoS profile for the PTP service consists of the following parameters which are negotiated or set to default values:

- service precedence (priority),
- reliability,
- delay,
- user data throughput.

5.4.2.3 Monitor

As an option, the MS may monitor the current QoS level. If this option is implemented, the following information shall be monitored:

- user data throughput;
- radio channel access delay;
- round-trip-MS/PLMN delay; and
- reliability.

The MS shall provide means of communicating this information to the application(s) via the R and S reference points as shown in Figure 2.

5.4.3 Security services

The use of radio communications for transmission to/from subscribers in mobile networks makes them particularly sensitive to:

- 1) misuse of their resources by unauthorized persons using manipulated MSs;
- 2) eavesdropping on the information being exchanged on the radio path.

Therefore, to protect the system in the two cases mentioned above, the following security features are provided for GPRS:

- MS authentication; i.e., the confirmation by the land-based part of the system that the subscriber identity, transferred by the MS within the identification procedure on the radio path, is the one claimed. The purpose of this authentication is to protect the network against unauthorized use. It also enables the protection of GPRS subscribers by denying intruders the ability to impersonate authorized users;
- access control; i.e., the network can support restrictions on access by or to different GPRS subscribers, such as restrictions by location, screening lists, and so on;
- user identity confidentiality; i.e., the property that the user identity on the radio link is not made available or disclosed to unauthorized individuals, entities or processes. The purpose is to provide privacy of identities of the subscribers who are using GPRS radio resources. It allows for the improvement of other security features, e.g., user information confidentiality, and also provides for the protection against tracing the location of a mobile subscriber by listening to the signalling exchanges on the radio path;
- user information confidentiality; i.e., the property that the user information is not made available or disclosed to unauthorized individuals, entities or processes. The purpose is to provide for confidentiality of user data, i.e., protection of the message part pertaining to layers 3 and above, that passes over the radio path.

Both user identity and user data shall be protected as shown in table 6:

Table 6: Protection of user identity and user data

Service	User Identity Protection	User Data Protection
PTP	Yes	Yes

Security mechanisms available for existing teleservices and bearer services should be used if possible.

An optional requirement is that an MS can anonymously initiate a mobile originated, PTP communication to a specific subscriber or server that is registered within the PLMN. This necessitates that all charges shall be made to the called party. For the access to the network the MS shall not send its IMSI or IMEI thus guaranteeing a high level of anonymity. However, in the case of fraud or misuse of the service, the MS shall transfer its IMEI and/or IMSI upon request by the operator. Authentication and ciphering procedures are not required. Such procedures may reside inside or outside the GSM network.

NOTE: An example for such an anonymous service is a toll road system whereby a user can pay the road-toll anonymously using a pre-paid card instead of a normal SIM card. The road-toll application server receives and is charged for all messages of the anonymous service. However, the server has its own means to charge the user (e.g. using electronic money on the anonymous pre-paid card).

5.4.4 Packet size

PTP service shall allow the transfer of variable length Network Service Data Units (NSDU).

5.4.5 Capabilities of GPRS MS Classes

The purpose of the definition of the GPRS MS Classes is to enable the different needs of the various market segments to be satisfied by a number of MS types with distinct capabilities (e.g., simultaneous use and number of time-slots). A means shall be provided to indicate the multi-slot capability and current configuration to the network when necessary.

Three GPRS MS classes are identified:

The term simultaneous (attach, traffic, etc.) is the requirement to simultaneously support GSM GPRS services and GSM circuit switched services including SMS.

Class A: Supports simultaneous attach, simultaneous activation, simultaneous monitor, simultaneous invocation and simultaneous traffic. The mobile user can make and/or receive calls on the two services simultaneously subject to the QoS requirements.

A minimum of one time slot shall be available for each type of service (circuit switched and GPRS) when required.

Class B: Supports simultaneous attach, simultaneous activation and simultaneous monitor. Supports only limited simultaneous invocation: GPRS virtual circuits (GPRS-activation) shall not be cleared down due to invocation or traffic of circuit switched services, the status of the GPRS virtual connection is then "busy or held". Simultaneous traffic shall not be supported. The mobile user can make and/or receive calls on either of the two services sequentially but not simultaneously. The selection of the appropriate service is performed automatically.

Class C: Supports only non-simultaneous attach. Alternate use only. If both services (GPRS and Circuit Switched) are supported then a Class C MS can make and/or receive calls only from the manually or default selected service, i.e., either GPRS or Circuit Switched service. The status of the service which has not been selected is detached i.e., not reachable. The capability for GPRS-attached class-C MSs to receive and transmit SMS messages is optional.

The network shall support SMS message reception and transmission for GPRS-attached class-C MSs.

An MS may be reconfigured. E.g., a class A MS configured as 1 slot for circuit switched plus 1 slot for GPRS may be reconfigured as a class C configured as 0 slots for circuit switched plus 2 slots for GPRS.

Non-voice only MSs do not have to (but may) support emergency calls.

5.4.6 Subscriber roaming

GPRS shall provide the ability for subscribers to access the service while roaming between networks. This implies the pre-existence of an international signalling mechanism and a service agreement between the different network operators involved.

GPRS is not required to provide the ability for subscribers to remain GPRS attached when moving from one PLMN to another. However, this may be possible by mutual agreement between operators.

5.4.7 Construction of GPRS subscriber numbers

The number of a GPRS subscriber shall be composed such that the PLMN operator can maintain control of the numbering scheme, thereby ensuring subscriber numbering integrity. The ability to allocate a subset of the numbers privately shall be possible.

5.4.8 Battery life extension

The GPRS service shall provide for a means to extend the battery life of an MS, by allowing the MS to reduce current drain; e.g., by using a discontinuous reception (DRX) strategy. The power conservation strategy should allow the MS to remain in a very low current state for a considerable proportion of the time. Moreover, the power conservation strategy should ensure that no messages are lost and that bandwidth is not wasted.

When conserving power through the use of DRX, or other techniques, the MS shall still meet all QoS requirements of selected classes. Some classes of service may necessitate continuous reception (i.e., no DRX capability).

5.4.9 Format Of Message User Data

The user data is to be presented as an octet string between GPRS's access points, and is not interpreted by the GSM PLMN.

5.4.10 Charging aspects

The charging information that the GPRS network collects for each MS shall be standardized. The information that the operator uses to generate a bill to a subscriber is operator specific. Billing aspects, e.g. a regular fee for a fixed period, are outside the scope of this specification.

The GSM HPLMN Operator/Service Provider may be able to charge the GPRS subscriber for all costs incurred including those costs incurred in an external network be it a GSM VPLMN or a non-GSM data network.

5.4.10.1 PTP charging information

The charging information of PTP service is collected for the GPRS subscriber. As a minimum the following charging information shall be collected:

- destination and source: The charging information shall describe the destination and source addresses;
- usage of radio interface: The charging information shall describe the amount of data transmitted in MO and MT directions categorized with QoS and user protocols;
- usage of the external data networks: The charging information shall describe the amount of data sent/received to/from the external data network;
- usage of the packet data protocol addresses: The charging information shall describe how long the MS has used the packet data protocol addresses;
- usage of the general GPRS resources: The charging information shall describe the usage of other GPRS related resources and MS's activity in the GPRS network (e.g. Attach/Detach, mobility management);
- location of MS: HPLMN, VPLMN, plus optional higher accuracy location information.

5.4.10.2 Reverse Charging

It shall be possible to provide reverse charging as a subscription option. However, reverse charging may not be applicable to certain external data network protocols.

5.4.11 Message Screening

The message screening function is concerned with filtering out unauthorized or unwanted messages. Message screening may be used to restrict the types of message or the volume of data which may be transferred across the GPRS network to/from an individual subscriber.

The PLMN administration and/or the GPRS service provider shall be able to provide basic screening functionality (e.g. firewall) to reduce the risk of fraud and misuse, to ensure the integrity of the network and to protect subscribers.

6 Normal procedures with successful outcome

6.1 Provision

The GPRS services shall be provided to the subscriber after prior arrangement with the service provider. The provision of each of the following GPRS services independently or any combination thereof shall be possible:

- 1) Point To Point - Connectionless Network Service (PTP-CLNS);

2) Point To Point - Connection Orientated Network Service (PTP-CONS);

It shall be possible to subscribe to GPRS services with or without subscription to other GSM services. When a subscriber has subscribed to the Multiple Subscriber Profile (MSP) GSM supplementary service, it shall be possible to assign GPRS services to each of the individual MSPs.

It shall be possible for the network operator to offer GPRS to the Service Provider(s) who may then offer GPRS-based services to the end-user.

GPRS services can be offered to a subscriber with the subscription option of using a password to control the services. A single GPRS-password per subscriber is supported by the network for all GPRS services.

As a subscription option modification of the subscriber's service profile (e.g., registration, erasure) shall be possible only in conjunction with the GPRS-password.

The following Quality of Service (QoS) parameters shall be assigned to the subscriber profile upon provision of the GPRS service(s). These parameters may be negotiated or set to default values:

- service precedence (priority);
- reliability;
- delay;
- user data throughput;
- scheduled repeated transmission.

6.2 Withdrawal

The service(s) shall be withdrawn at the subscriber's request or for administrative reasons. Withdrawal shall de-activate the service.

6.3 GPRS-Attach, GPRS-Detach

GPRS-Attach is performed when the MS indicates its presence to the PLMN for the purpose of using the GPRS PTP service. This can be immediately after the MS has been switched on or later as the user decides to use the GPRS services. The MS identifies itself with its GSM identity (IMSI, TLLI). A GPRS-Attach shall be successfully performed only if the subscriber has a valid GPRS subscription. It is assumed that the user will not, under normal circumstances, initiate a GPRS Attach without first ensuring that the data handling capability necessary in the terminating equipment has been activated.

GPRS-Detach is performed when the MS indicates to the PLMN that the MS will no longer be using the GPRS services. The MS identifies itself with its GSM identity (IMSI, TLLI).

6.4 Registration

Registration of the service parameters shall enable the subscriber to optimize the actual (dynamic) service profile to the subscriber's present, actual requirements within the limitations of the (static) subscription profile (see subclause 6.1). The result of the registration shall be indicated (i.e. accepted/registered or rejected/not registered). The registered service profile is valid for all GPRS transactions until modified by re-registration or erasure or changes to the subscription profile.

As a subscription option registration of the service parameters shall be possible only in conjunction with a GPRS-password.

Table 7 defines which service parameters shall be able to be registered for the different GPRS services. The range of values for the service parameters is specified in subclause 5.4 and subclause 5.4.2.1.

Table 7: Registration of service parameters

Service Parameter	PTP-CLNS PTP-CONS			
Service precedence (priority)	2,3,4			
Reliability	2,4			
Throughput	2, 3, 4			
Simultaneous use class	2			
Delay	2, 4			
Security management / encryption	1			
Interworking profile (a)	2			
Password Active / De-active	2			

Legend: 1 Network determined.

2 User determined per subscription and registration.

3 User determined per request.

4 Negotiable.

- a) This is the set of subscription attributes (including a user-ID and/or address valid in the external data network if necessary) adopted by the subscriber when utilizing a particular destination network. A set of subscription attributes is required for each destination network. Multiple user-IDs and/or addresses for each destination network are allowed. See subclause 11.1 for address management.

Registration of a non-GSM identity (i.e. a user-ID/address in an external data network, e.g. Internet, X.25 etc.) is performed to couple the non-GSM identity to the GSM identity (IMSI) for the purpose of accessing (MO and/or MT) the non-GSM network. Registration of a non-GSM identity is subject to valid subscription agreements with the network operator. This also provides an effective operator determined barring of access to external data networks.

Each of the registered interworking profiles can be individually activated and de-activated.

Screening parameters can be assigned to a particular interworking profile as a user protection against unwanted costs and/or data.

6.5 Erasure

The subscriber shall be able to erase previously registered service parameter values from the service profile.

Erasure of a non-GSM identity (e.g., Internet, X.25) which is currently registered for an interworking profile shall be possible without erasure of the other parameters of the interworking profile.

As a subscription option erasure shall only be possible in conjunction with the GPRS-password.

6.6 Interrogation

The subscriber shall be able to interrogate the status/value of registered service parameters as defined in the current service profile.

6.7 Activation

The subscriber shall be able to activate each of the registered interworking profiles independently within the limitations of the subscription profile. As an option the GPRS network may request the activation of a specific interworking profile for a GPRS attached mobile, when an mobile terminated packet is received. This option may be available for one or more PDP. The activation of the inter-working profile(s) may be performed automatically by the MS immediately after GPRS Attach. When an interworking profile is activated a dynamic binding between the GSM/GPRS identity of the MS and the external data network user-ID and/or address is made by the system, and the appropriate service parameters

are applied thus establishing a virtual connection between the MS and the GPRS network. Activation of an interworking profile results in a dynamic binding until de-activation is performed.

6.8 De-activation

The subscriber shall be able to de-activate the previously activated interworking profiles independently within the limitations of the subscription profile thus releasing the previously established virtual connection. An interworking profile(s) shall be automatically de-activated if the provision for the supporting GPRS service is withdrawn. Interworking profiles are deactivated automatically upon GPRS detach..

De-activation of a particular interworking profile shall abort all presently on-going communication between the MS and the external data network.

6.9 Invocation and operation

The GPRS service is invoked upon transmission or reception of GPRS data.

It shall be possible for a MS to be a GPRS service requester and a service receiver. This allows generation and origination of GPRS messages from the mobile termination itself as a standalone GPRS data source. It also allows the mobile termination to provide DCE capabilities for user applications based in terminal equipment outside the mobile termination.

It shall be possible for a subscriber to set-up multiple GPRS PTP-CONS communication sessions and maintain these over prolonged periods (e.g. several hours). It shall be possible to establish these connections via more than one external data network. This enables more than one logical data channel to exist to a single mobile termination.

PTP-CONS and/or PTP-CLNS communications in combination shall be possible in parallel. In the case of X.25 the concept of switched virtual circuits shall be maintained between the GPRS environment and the X.25 fixed network.

6.10 PIN and Password Management

GPRS-Attach shall only be possible after correct subscriber identification has been confirmed by entry of the current GSM PIN if this option is active. Thus only one PIN is required to gain access to either the GSM-Circuit Switched Services/SMS or the GSM-GPRS Services or both.

GPRS services can be offered to a subscriber with the subscription option of using a password to control the services. One password per subscriber is supported by the network for all GPRS services. The GPRS password shall be the GSM specified password for supplementary services according to the GSM specifications 02.04 [18] and 02.30 [19].

When this option is selected the following actions shall only be performed with the concurrent entry of the password:

- registration, de-registration/erasure;

7 Exceptional procedures

7.1 Provision

None.

7.2 Withdrawal

None.

7.3 Registration

An attempt to register a service or service parameter not available to that subscriber shall result in an indication to the user. The reason shall be indicated:

- the service or service parameter is not supported by the PLMN;
- the subscriber's present (static) subscription profile prohibits the use of this service or service parameter;
- parameter is network determined;
- the entered parameter value is outside the range of that supported by the PLMN.

If, in the case of interworking with an external data network, an attempt is made to set a parameter to a value outside the range of that supported by the interworking to the external data network, it shall be indicated to the user and confirmation required before the parameter value is changed to a value selected by the network.

7.4 Erasure

An attempt to erase a service parameter which is not registered shall result in an indication to the user, the service parameter shall remain in the not registered state.

Erasure of a non-GSM identity (e.g., Internet, X.25) which is presently registered as "active" shall result in an indication to the user with a request for confirmation before the de-activation and erasure is performed.

7.5 Interrogation

None.

7.6 Activation

An attempt to activate an interworking profile which is already in the active state shall result in an indication to the user, the interworking profile shall remain in the active state.

7.7 De-activation

An attempt to de-activate an interworking profile which is already in the de-active state shall result in an indication to the user, the interworking profile shall remain in the de-active state.

7.8 Invocation and operation

An attempt to send an MO message with an MS identity which is not valid in the network shall be rejected with an appropriate error status.

An MT message that cannot be delivered due to an invalid MS identity shall be discarded by the network. A message that is received by an incorrect MS shall be discarded by the MS.

7.9 PIN and Password management

PIN and password exceptional procedures are as defined in GSM specifications 02.17 [20] and 02.04 [18].

8 Addressing

A GPRS-PTP subscription is identified by an IMSI.

How the identities are used within the different services is described in table 8.

Table 8: Services and Identities

Services	mobile originated		mobile terminated
	calling party	called party	
GPRS PTP	IMSI	Address (note 1)	IMSI
GPRS PTP-anonymous originator. (note 2)	-	Server ID	not applicable
NOTE 1: The IMSI or in the case of network interworking refer to subclause 11.3.			
NOTE 2: The subscriber and user identities of a PTP-anonymous-originator message are hidden from the operator.			

10 Service interworking

It shall be possible for the GPRS PTP services to be utilized as a bearer service for the SMS-MO and SMS-MT services.

11 Network interworking

Network interworking is required whenever a PLMN and a non-PLMN are involved in the execution of a GPRS Service request.

In general the mobile user of a GPRS network will receive and experience all the services provided by an external data network. In this case the external data network refers to the network that the GPRS PLMN interworks with as determined by the network operator. With this in mind it can be said that a user :-

- 1) will require a universal identity(ies) of the form compatible with the interworked with network(s);
- 2) and experience access to and provision of all services as offered by the interworked with networks (some reduction of capability may result from unavoidable restrictions due to the complexity of implementation).

11.1 Interworking with other data networks and other PLMNs

GPRS shall provide means to interwork with external data networks. The GPRS operator provides an appropriate address to the external data network for the subscriber as part of the GPRS subscription. That address can be either dynamic (e.g. the user's IP address is allocated from a pool of unused IP addresses every time the subscriber activates the access to an IP network) or static (e.g. a certain IP address is permanently allocated to a particular subscriber). When connected with some external data networks, the routing protocols of these networks may limit the data network addresses that can be allocated. For example, when interworking with IP networks, the IP address for the GPRS subscriber shall belong to that GPRS operator's IP subnetwork that allocates the address.

The type of interworking between a PLMN and data networks is determined by the network operator.

Interworking with the following types of data networks shall be defined:

- X.25 networks;
- IP networks;
- other GPRS PLMNs, directly or via a transit network;

The MS should interwork with the X.25 network using standardized X.3, X.28 and X.29 mechanisms for asynchronous access and X.25 mechanisms for synchronous access.

11.1.1 QoS when Interworking

GPRS shall satisfy, within the constraints introduced by the mobile radio environment, the QoS requirements of the interworked-with network.

11.2 GPRS Numbering Plan

It is required that GPRS MS addresses conform to the numbering plan already defined for GSM.

11.3 Addressing and routeing requirements

A GPRS subscriber identified by an IMSI, shall have a network layer address(es) temporarily and/or permanently associated with it that conforms to the standard addressing scheme of the respective network layer service used, e.g.:

- E.164 number;
- X.121 address for X.25 CONS;
- IP Version 4 and 6 addresses for Internet CLNS.

11.4 Interworking for subscriber roaming

Interworking between different GPRS PLMNs is required in order to support subscriber roaming.

It shall be possible for the VPLMN to provide access to the external data network when the external non-GSM data network address is dynamically assigned by the VPLMN.

Annex A (Informative): Change history

Change history					
SMG No.	TDoc. No.	CR. No.	Clauses affected	New version	Subject/Comments
		A001			
SMG#24	976/97	A002	The complete revised Stage 1 is attached for clarity.	5.2.0	Clarification of GPRS release 1997 content and minor editorial improvements
SMG#24	976/97	A003	Sub-Clauses: 5.4.1, 5.4.2, 6.1 and 6.4.	5.2.0	Clarification/Improvement of definition of Quality of Services aspects
SMG#25	071/98	A004	Sub-Clause: 5.4.2.1.4	6.0.0	Allowing re-negotiation of the QoS parameters for throughput during a session improves the flexibility of network operation and increases the quality of service perceived by the user.
SMG#25	071/98	A005	Sub-Clause: 5.4.5	6.0.0	Requirement for the MS to inform the network of its GPRS class is not appropriate for the stage 1 and should be left for the stage 2 to determine. The three MS classes A, B, C remain unchanged
SMG#25	071/98	A006	Sub-Clause: 6.3	6.0.0	Clarification of the GPRS Attach characteristics. A GPRS-Attach shall be successfully performed only if the subscriber has a valid GPRS subscription. It is assumed that the user will not, under normal circumstances, initiate a GPRS Attach without first ensuring that the data handling capability necessary in the terminating equipment has been activated
SMG#26	98-0320	A007	All	6.1.0	The GSM 02.60 contains a lot of text related to GPRS phase 2, which has to be removed from the R97 specification. The Phase 2 Version of 02.60 remains unaffected by this change.

History

Document history		
V6.1.0	July 1998	One-step Approval Procedure OAP 9847: 1998-07-24 to 1998-11-20