

**Broadband Integrated Services Digital Network (B-ISDN);  
Digital Subscriber Signalling System No. two (DSS2) protocol;  
Connection characteristics;  
ATM transfer capability and traffic parameter indication;  
Part 4: Abstract Test Suite (ATS) and partial  
Protocol Implementation eXtra Information for Testing (PIXIT)  
proforma specification for the network**

---



---

**Reference**

DEN/SPAN-05150-6

---

**Keywords**B-ISDN, DSS2, ATM, testing, ATS, PIXIT,  
network**ETSI**

---

**Postal address**

F-06921 Sophia Antipolis Cedex - FRANCE

---

**Office address**650 Route des Lucioles - Sophia Antipolis  
Valbonne - FRANCE  
Tel.: +33 4 92 94 42 00 Fax: +33 4 93 65 47 16  
Siret N° 348 623 562 00017 - NAF 742 C  
Association à but non lucratif enregistrée à la  
Sous-Préfecture de Grasse (06) N° 7803/88

---

**Internet**

secretariat@etsi.fr

Individual copies of this ETSI deliverable  
can be downloaded from  
<http://www.etsi.org>If you find errors in the present document, send your  
comment to: editor@etsi.fr

---

**Important notice**

This ETSI deliverable may be made available in more than one electronic version or in print. In any case of existing or perceived difference in contents between such versions, the reference version is the Portable Document Format (PDF). In case of dispute, the reference shall be the printing on ETSI printers of the PDF version kept on a specific network drive within ETSI Secretariat.

---

**Copyright Notification**

No part may be reproduced except as authorized by written permission.  
The copyright and the foregoing restriction extend to reproduction in all media.

© European Telecommunications Standards Institute 1999.  
All rights reserved.

# Contents

|   |           |
|---|-----------|
| Intellectual Property Rights .....  | 5         |
| Foreword.....   | 5         |
| 1 Scope .....   | 6         |
| 2 References .....  | 6         |
| 3 Definitions and abbreviations .....   | 7         |
| 3.1 Definitions .....   | 7         |
| 3.1.1 Definitions related to conformance testing .....                            | 7         |
| 3.1.2 Definitions related to EN 301 068-1 .....                                   | 7         |
| 3.2 Abbreviations .....   | 8         |
| 4 Abstract Test Method (ATM) .....  | 8         |
| 4.1 Description of ATM used .....   | 8         |
| 4.2 Conventions for test components and PCOs.....                                 | 9         |
| 5 Untestable test purposes .....  | 10        |
| 6 ATS to TP map.....  | 10        |
| 7 PCTR conformance .....  | 10        |
| 8 PIXIT conformance .....   | 11        |
| 9 ATS Conformance.....  | 11        |
| <b>Annex A (normative): Protocol Conformance Test Report (PCTR) proforma.....</b> | <b>12</b> |
| A.1 Identification summary .....  | 12        |
| A.1.1 Protocol conformance test report.....                                       | 12        |
| A.1.2 IUT identification .....  | 12        |
| A.1.3 Testing environment .....   | 12        |
| A.1.4 Limits and reservations.....  | 13        |
| A.1.5 Comments.....   | 13        |
| A.2 IUT Conformance status .....  | 13        |
| A.3 Static conformance summary .....  | 13        |
| A.4 Dynamic conformance summary.....  | 14        |
| A.5 Static conformance review report .....  | 14        |
| A.6 Test campaign report.....   | 14        |
| A.7 Observations.....   | 15        |
| <b>Annex B (normative): Partial PIXIT proforma.....</b>                           | <b>16</b> |
| B.1 Identification summary .....  | 16        |
| B.2 Abstract test suite summary .....   | 16        |
| B.3 Test laboratory .....   | 16        |
| B.4 Client (of the Test Laboratory) .....   | 17        |
| B.5 SUT .....   | 17        |
| B.6 Protocol information .....  | 18        |
| B.6.1 Protocol identification .....   | 18        |
| B.6.2 Configuration to be tested.....   | 18        |
| B.6.3 Test management timers .....  | 18        |
| B.6.4 Parameter Values.....   | 19        |

|                             |   |           |
|-----------------------------|---|-----------|
| <b>Annex C (normative):</b> | <b>Abstract Test Suite (ATS)</b> .....            | <b>20</b> |
| C.1                         | The TTCN Graphical form (TTCN.GR).....            | 20        |
| C.2                         | The TTCN Machine Processable form (TTCN.MP) ..... | 20        |
| History                     | .....   | 21        |

---

## Intellectual Property Rights

IPRs essential or potentially essential to the present document may have been declared to ETSI. The information pertaining to these essential IPRs, if any, is publicly available for **ETSI members and non-members**, and can be found in SR 000 314: *"Intellectual Property Rights (IPRs); Essential, or potentially Essential, IPRs notified to ETSI in respect of ETSI standards"*, which is available from the ETSI Secretariat. Latest updates are available on the ETSI Web server (<http://www.etsi.org/ipr>).

Pursuant to the ETSI IPR Policy, no investigation, including IPR searches, has been carried out by ETSI. No guarantee can be given as to the existence of other IPRs not referenced in SR 000 314 (or the updates on the ETSI Web server) which are, or may be, or may become, essential to the present document.

---

## Foreword

This European Standard (Telecommunications series) has been produced by ETSI Technical Committee Services and Protocols for Advanced Networks (SPAN), and is now submitted for the Public Enquiry phase of the ETSI standards Two-step Approval Procedure.

The present document is part 6 of a multi-part EN covering the Digital Subscriber Signalling System No. 2 (DSS2) protocol specification for the B-ISDN ATM transfer capability and traffic parameter indication, as described below:

Part 1: "Protocol specification";

Part 2: "Protocol Implementation Conformance Statement (PICS) proforma specification";

Part 3: "Test Suite Structure and Test Purposes (TSS&TP) specification for the user";

Part 4: "Abstract Test Suite (ATS) and partial Protocol Implementation eXtra Information for Testing (PIXIT) proforma specification for the user";

Part 5: "TSS&TP specification for the network";

**Part 6: "Abstract Test Suite (ATS) and partial Protocol Implementation eXtra Information for Testing (PIXIT) proforma specification for the network".**

| <b>Proposed national transposition dates</b>   |                                 |
|--|---------------------------------|
| Date of latest announcement of this EN (doa):  | 3 months after ETSI publication |
| Date of latest publication of new National Standard or endorsement of this EN (dop/e): | 6 months after doa              |
| Date of withdrawal of any conflicting National Standard (dow):                         | 6 months after doa              |

---

# 1 Scope

This sixth part of EN 301 068 specifies the network Abstract Test Suite (ATS) for the  $T_B$  reference point or coincident  $S_B$  and  $T_B$  reference point (as defined in ITU-T Recommendation I.413 [6]) of implementations conforming to the standards for the signalling user-network layer 3 specification for ATM transfer capability and traffic parameter indication of the Digital Subscriber Signalling System No. two (DSS2) protocol for the pan-European Broadband Integrated Services Digital Network (B-ISDN), EN 301 068-1 [1].

A further part of the present document specifies the Test Suite Structure and Test Purposes (TSS&TP) related to this ATS and partial PIXIT proforma. Other parts specify the TSS&TP and the ATS and partial PIXIT proforma for the User side of the  $T_B$  reference point or coincident  $S_B$  and  $T_B$  reference point of implementations conforming to EN 301 068-1 [1].

---

# 2 References

The following documents contain provisions which, through reference in this text, constitute provisions of the present document.

- References are either specific (identified by date of publication, edition number, version number, etc.) or non-specific.
- For a specific reference, subsequent revisions do not apply.
- For a non-specific reference, the latest version applies.
- A non-specific reference to an ETS shall also be taken to refer to later versions published as an EN with the same number.

- [1] EN 301 068-1: "Broadband Integrated Services Digital Network (B-ISDN); Digital Subscriber Signalling System No. two (DSS2) protocol; Connection characteristics; ATM transfer capability and traffic parameter indication; Part 1: Protocol specification [ITU-T Recommendations Q.2961.1 (1995), Q.2961.2 (1997), Q.2961.3 (1997), Q.2961.4 (1997), modified]".
- [2] EN 301 068-2: "Broadband Integrated Services Digital Network (B-ISDN); Digital Subscriber Signalling System No. two (DSS2) protocol; Connection characteristics; ATM transfer capability and traffic parameter indication; Part 2: Protocol Implementation Conformance Statement (PICS) proforma specification".
- [3] ISO/IEC 9646-1: "Information technology; Open Systems Interconnection; Conformance testing methodology and framework; Part 1: General concepts".
- [4] ISO/IEC 9646-2: "Information technology; Open Systems Interconnection; Conformance testing methodology and framework; Part 2: Abstract Test Suite specification".
- [5] ISO/IEC 9646-3: "Information technology; Open Systems Interconnection; Conformance testing methodology and framework; Part 3: The Tree and Tabular Combined Notation (TTCN)".
- [6] ITU-T Recommendation I.413 (1993): "B-ISDN user-network interface".
- [7] ETS 300 406: "Methods for Testing and Specification (MTS); Protocol and profile conformance testing specifications; Standardization methodology".
- [8] EN 300 443-1: "Broadband Integrated Services Digital Network (B-ISDN); Digital Subscriber Signalling System No. two (DSS2) protocol; B-ISDN user-network interface layer 3 specification for basic call/bearer control; Part 1: Protocol specification [ITU-T Recommendation Q.2931 (1995), modified]".
- [9] ISO/IEC 9646-4: "Information technology; Open Systems Interconnection; Conformance testing methodology and framework; Part 4: Test realization".

- [10] ISO/IEC 9646-5: "Information technology; Open Systems Interconnection; Conformance testing methodology and framework; Part 5: Requirements on test laboratories and clients for the conformance assessment process".
- [11] ETS 300 443-2: "Broadband Integrated Services Digital Network (B-ISDN); Digital Subscriber Signalling System No. two (DSS2) protocol; B-ISDN user-network interface layer 3 specification for basic call/bearer control; Part 2: Protocol Implementation Conformance Statement (PICS) proforma specification".

---

## 3 Definitions and abbreviations

### 3.1 Definitions

For the purposes of the present document, the following terms and definitions apply, in addition to those given in EN 301 068-1[1] and EN 300 443-1 [8]:

#### 3.1.1 Definitions related to conformance testing

**Abstract test case:** refer to ISO/IEC 9646-1 [3]

**Abstract Test Method (ATM):** refer to ISO/IEC 9646-1 [3]

**Abstract Test Suite (ATS):** refer to ISO/IEC 9646-1 [3]

**Implementation Under Test (IUT):** refer to ISO/IEC 9646-1 [3]

**System Under Test (SUT):** see ISO/IEC 9646-1 [3]

**Upper Tester (UT):** see ISO/IEC 9646-1 [3]

**Lower tester:** refer to ISO/IEC 9646-1 [3]

**Protocol Implementation Conformance Statement (PICS):** refer to ISO/IEC 9646-1 [3]

**PICS proforma:** refer to ISO/IEC 9646-1 [3]

**Protocol Implementation eXtra Information for Testing (PIXIT):** refer to ISO/IEC 9646-1 [3]

**PIXIT proforma:** refer to ISO/IEC 9646-1 [3]

**Test Purpose (TP):** refer to ISO/IEC 9646-1 [3]

**Point of Control and Observation (PCO):** see ISO/IEC 9646-1 [3]

#### 3.1.2 Definitions related to EN 301 068-1

**user:** the DSS2 protocol entity at the User side of the user-network interface where a TB reference point or coincident SB and TB reference point applies

**user (SB/TB):** the DSS2 protocol entity at the User side of the user-network interface where a coincident SB and TB reference point applies

**user (TB):** the DSS2 protocol entity at the User side of the user-network interface where a TB reference point applies (user is a private ISDN)

## 3.2 Abbreviations

For the purposes of the present document, the following abbreviations apply:

|         |   |
|---------|---|
| ATM     | Abstract Test Method                                  |
| ATS     | Abstract Test Suite                                   |
| B-ISDN  | Broadband Integrated Services Digital Network         |
| CR      | Call Reference  |
| DSS2    | Digital Subscriber Signalling System No. two          |
| IE_flag | Information element instruction indicator flag        |
| IE_AI   | Information element action indicator                  |
| IUT     | Implementation Under Test                             |
| PICS    | Protocol Implementation Conformance Statement         |
| PIXIT   | Protocol Implementation eXtra Information for Testing |
| TSS     | Test Suite Structure                                  |
| ExTS    | Executable Test Suite                                 |
| LT      | Lower Tester  |
| MOT     | Means Of Testing                                      |
| PCO     | Point of Control and Observation                      |
| PDU     | Protocol Data Unit                                    |
| SUT     | System Under Test                                     |
| TP      | Test Purpose  |
| TTCN    | Tree and Tabular Combined Notation                    |
| UT      | Upper Tester  |
| VC      | Virtual Channel                                       |
| VCI     | Virtual Channel Identifier                            |
| VPC     | Virtual Path Connection                               |
| VPCI    | Virtual Path Connection Identifier                    |
| VP      | Virtual Path  |

---

## 4 Abstract Test Method (ATM)

### 4.1 Description of ATM used

The requirement for testing the network IUT is to focus on the behaviour of the network IUT at the user-network interface where a  $T_B$  reference point or coincident  $S_B$  and  $T_B$  reference point applies. Thus the IUT is the network DSS2 protocol entity at a particular user-network interface and is not the whole network.

It is possible to specify an ATS based on a Single party (remote) test method for such an IUT. However, it is considered that an ATS based on such an approach is of limited use as the only way to specify IUT generated PDUs is to use the "implicit send" statement. Many users of such an ATS would replace the "implicit send" statements with descriptions of the behaviour at other interfaces.

An ATS based on a multi-party test method is considered to be more useful in that it is closer to how a real test suite would be constructed. Such a test method specifies behaviour at multiple network interfaces. One very important limitation here is that tests are focussed on one particular interface. Thus the test system is made up one Main Test Component (MTC) and one or more Parallel Test Components (PTC), see figure 1.



## 4.2 Conventions for test components and PCOs

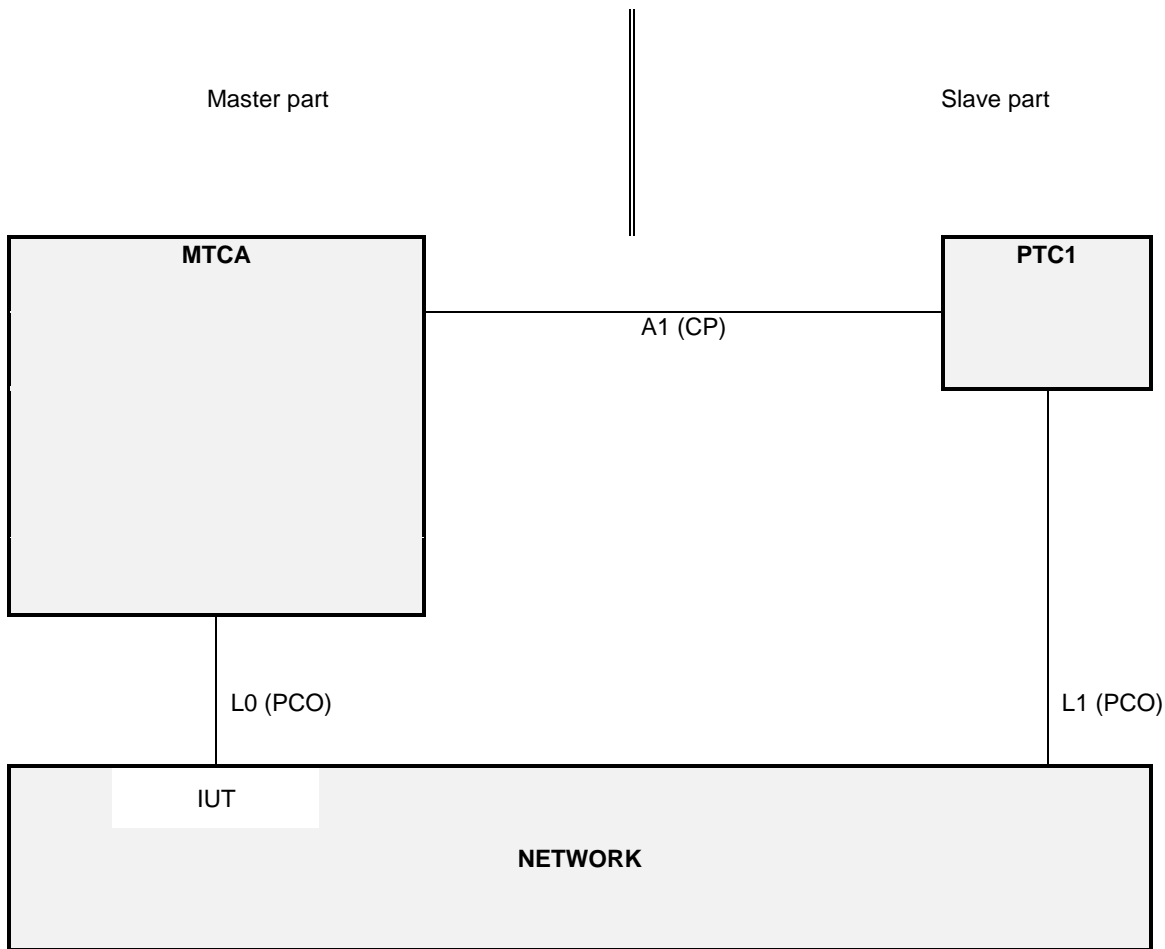

**Figure 1: Multi-party test method**

In a master/slave arrangement, the MTC is considered to be the master while the PTCs are the slaves. The "slave" testers are only an explicit description of how to deal with the remote interfaces during the testing process, i.e. "how to make the IUT send the required message".

This means, in particular, that the verdict will only be assigned from the protocol aspects observed on *the* interface under test (i.e. by the "master" tester), as it would be observed by a terminal connected to this interface. A failure in the correlation between the protocol at the different interfaces to which the different testers are connected, i.e. in the mechanism of the functional service itself, will not cause a FAIL verdict. For instance, if the IUT fails to send a message on the tested interface after another interface has received the proper stimulus, the verdict will be INCONCLUSIVE.

The MTC MTCA has two functions in this configuration. Firstly, it has the MTC function of controlling the one or more PTCs. Thus it is responsible for starting the PTCs and afterwards co-ordinates activities by exchanging Co-ordination Messages (CM) with the PTCs. Secondly it is responsible for the behaviour of the Lower Tester (LT) at PCO L0.

A combination of the remote and multi-party test methods is applied. As can be seen from figure 1, several PCOs are used. All PCOs reside at the service access points between layers 2 and 3.

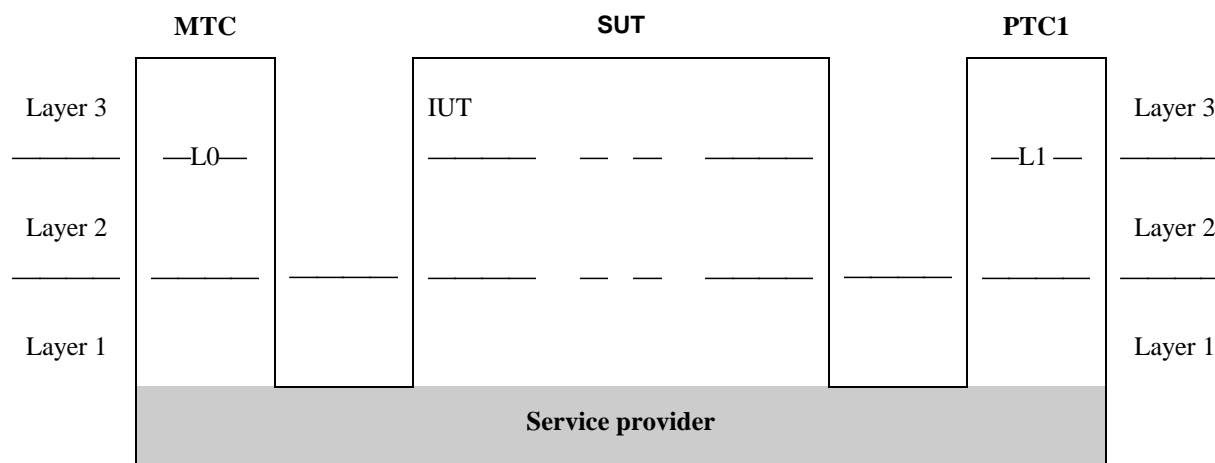

**Figure 2: Combination of the remote and multi-party test methods**

The MTC PCO is named "L0" ("L" for Lower). The L0 PCO is used to control and observe the behaviour of the IUT and test case verdicts are assigned depending on the behaviour observed at this PCO. The PTCs PTC1, PTC2 etc. use PCOs L1, L2 etc. These PCOs are used to control and, in a limited way, observe the behaviour of the network equipment at interfaces other than the one under test. No verdicts are assigned at these PCOs.

As stated in a previous paragraph, the non-receipt of network generated messages at L0, which are stimulated by events at the L1, L2 etc., will result in INCONCLUSIVE rather than FAIL verdicts being assigned.

PTC2 is only activated in that test cases that test the procedures at the access between a root user and the IUT, when more than one party is involved in the call between the root user and the IUT. In test cases which verify that the IUT rejects invalid or unacceptable SETUP messages, no PTC is activated at all, as these rejection procedures are considered local to the access between IUT and MTC.

---

## 5 Untestable test purposes

There are no untestable test purposes associated with this ATS.

---

## 6 ATS to TP map

The identifiers used for the TPs are reused as test case names. Thus there is a straightforward one-to-one mapping.

---

## 7 PCTR conformance

A test laboratory, when requested by a client to produce a PCTR, is required, as specified in ISO/IEC 9646-5 [10], to produce a PCTR conformant with the PCTR template given in annex B of ISO/IEC 9646-5 [10].

Furthermore, a test laboratory, offering testing for the ATS specification contained in annex C, when requested by a client to produce a PCTR, is required to produce a PCTR conformant with the PCTR proforma contained in annex A of the present document.

A PCTR which conforms to this PCTR proforma specification shall preserve the content and ordering of the clauses contained in annex A. Clause A.6 of the PCTR may contain additional columns. If included, these shall be placed to the right of the existing columns. Text in italics may be retained by the test laboratory.

---

## 8 PIXIT conformance

A test realizer, producing an executable test suite for the Abstract Test Suite (ATS) specification contained in annex C, is required, as specified in ISO/IEC 9646-4 [9], to produce an augmented partial PIXIT proforma conformant with this partial PIXIT proforma specification.

An augmented partial PIXIT proforma which conforms to this partial PIXIT proforma specification shall, as a minimum, have contents which are technically equivalent to annex B. The augmented partial PIXIT proforma may contain additional questions that need to be answered in order to prepare the Means Of Testing (MOT) for a particular Implementation Under Test (IUT).

A test laboratory, offering testing for the ATS specification contained in annex C, is required, as specified in ISO/IEC 9646-5 [10], to further augment the augmented partial PIXIT proforma to produce a PIXIT proforma conformant with this partial PIXIT proforma specification.

A PIXIT proforma which conforms to this partial PIXIT proforma specification shall, as a minimum, have contents which are technically equivalent to annex B. The PIXIT proforma may contain additional questions that need to be answered in order to prepare the test laboratory for a particular IUT.

---

## 9 ATS Conformance

The test realizer, producing a Means Of Testing (MOT) and Executable Test Suite (ExTS) for this Abstract Test Suite (ATS) specification, shall comply with the requirements of ISO/IEC 9646-4 [9]. In particular, these concern the realization of an Executable Test Suite (ExTS) based on each ATS. The test realizer shall provide a statement of conformance of the MOT to this ATS specification.

An ExTS which conforms to this ATS specification shall contain test groups and test cases which are technically equivalent to those contained in the ATS in annex C. All sequences of test events comprising an abstract test case shall be capable of being realized in the executable test case. Any further checking which the test system might be capable of performing is outside the scope of this ATS specification and shall not contribute to the verdict assignment for each test case.

Test laboratories running conformance test services using this ATS shall comply with ISO/IEC 9646-5 [10].

A test laboratory which claims to conform to this ATS specification shall use an MOT which conforms to this ATS.

## Annex A (normative): Protocol Conformance Test Report (PCTR) proforma

Notwithstanding the provisions of the copyright clause related to the text of the present document, ETSI grants that users of the present document may freely reproduce the PCTR proforma in this annex so that it can be used for its intended purposes and may further publish the completed PCTR.

### A.1 Identification summary

#### A.1.1 Protocol conformance test report

|                                 |  |
|---------------------------------|--|
| PCTR number:                    |  |
| PCTR Date:                      |  |
| Corresponding SCTR number:      |  |
| Corresponding SCTR date:        |  |
| Test Laboratory identification: |  |
| Test Laboratory Manager:        |  |
| Signature:                      |  |

#### A.1.2 IUT identification

|                         |              |
|-------------------------|--------------|
| Name:                   |              |
| Version:                |              |
| Protocol specification: | EN 301 068-1 |
| PICS:                   |              |
| Previous PCTRs (if any) |              |

#### A.1.3 Testing environment

|                                      |  |
|--------------------------------------|--|
| PIXIT Reference number:              |  |
| ATS Specification:                   | EN 301 068-6                                 |
| Abstract Test Method:                | Multi-party test method (see ISO/IEC 9646-2) |
| Means of Testing identification:     |  |
| Dates of testing:                    |  |
| Conformance Log reference(s):        |  |
| Retention Date for Log reference(s): |  |

## A.1.4 Limits and reservations

*Additional information relevant to the technical contents or further use of the test report, or to the rights and obligations of the test laboratory and the client, may be given here. Such information may include restriction on the publication of the report.*

---

---

---

---

---

## A.1.5 Comments

*Additional comments may be given by either the client or the test laboratory on any of the contents of the PCTR, for example, to note disagreement between the two parties.*

---

---

---

---

---

## A.2 IUT Conformance status

This IUT has or has not been shown by conformance assessment to be non-conforming to the specified protocol specification.

*Strike the appropriate words in this sentence. If the PICS for this IUT is consistent with the static conformance requirements (as specified in clause A.3 of this report) and there are no "FAIL" verdicts to be recorded (in clause A.6) strike the words "has or", otherwise strike the words "or has not".*

---

## A.3 Static conformance summary

The PICS for this IUT is or is not consistent with the static conformance requirements in the specified protocol.

*Strike the appropriate words in this sentence.*

## A.4 Dynamic conformance summary

The test campaign did or did not reveal errors in the IUT.

*Strike the appropriate words in this sentence. If there are no "FAIL" verdicts to be recorded (in clause A.6 of this report) strike the words "did or", otherwise strike the words "or did not".*

Summary of the results of groups of tests:

---



---



---



---

## A.5 Static conformance review report

*If clause A.3 indicates non-conformance, this subclause itemizes the mismatches between the PICS and the static conformance requirements of the specified protocol specification.*

---



---



---



---



---



---

## A.6 Test campaign report

| ATS Reference   | Selected ?<br>(Y/N) | Run ?<br>(Y/N) | Verdict | Observations |
|---|---------------------|----------------|---------|--------------|
| Signalling procedures at the coincident S <sub>B</sub> /T <sub>B</sub> and at the T <sub>B</sub> reference points |                     |                |         |              |
| INDN_01_01  |                     |                |         |              |
| INDN_01_02  |                     |                |         |              |
| INDN_02_01  |                     |                |         |              |
| INDN_02_02  |                     |                |         |              |
| INDN_02_03  |                     |                |         |              |
| INDN_02_04  |                     |                |         |              |
| INDN_02_05  |                     |                |         |              |
| INDN_03_01  |                     |                |         |              |
| INDN_04_01  |                     |                |         |              |
| INDN_04_02  |                     |                |         |              |
| INDN_04_03  |                     |                |         |              |
| INDN_04_04  |                     |                |         |              |
| INDN_04_05  |                     |                |         |              |
| INDN_05_01  |                     |                |         |              |
| INDN_05_02  |                     |                |         |              |
| INDN_05_03  |                     |                |         |              |
| INDN_05_04  |                     |                |         |              |
| INDN_06_01  |                     |                |         |              |
| INDN_06_02  |                     |                |         |              |
| INDN_06_03  |                     |                |         |              |
| INDN_06_04  |                     |                |         |              |

| ATS Reference | Selected ?<br>(Y/N) | Run ?<br>(Y/N) | Verdict | Observations |
|---------------|---------------------|----------------|---------|--------------|
| INDN_06_05    |                     |                |         |              |
| INDN_06_06    |                     |                |         |              |
| INDN_07_01    |                     |                |         |              |
| INDN_07_02    |                     |                |         |              |
| INDN_08_01    |                     |                |         |              |
| INDN_08_02    |                     |                |         |              |
| INDN_08_03    |                     |                |         |              |
| INDN_08_04    |                     |                |         |              |
| INDN_08_05    |                     |                |         |              |
| INDN_08_06    |                     |                |         |              |
| INDN_08_07    |                     |                |         |              |
| INDN_08_08    |                     |                |         |              |
| INDN_08_09    |                     |                |         |              |
| INDN_08_10    |                     |                |         |              |
| INDN_08_11    |                     |                |         |              |
| INDN_08_12    |                     |                |         |              |
| INDN_08_13    |                     |                |         |              |
| INDN_08_14    |                     |                |         |              |
| INDN_09_01    |                     |                |         |              |
| INDN_10_01    |                     |                |         |              |
| INDN_10_02    |                     |                |         |              |
| INDN_10_03    |                     |                |         |              |
| INDN_11_01    |                     |                |         |              |
| INDN_11_02    |                     |                |         |              |
| INDN_12_01    |                     |                |         |              |
| INDN_12_02    |                     |                |         |              |
| INDN_12_03    |                     |                |         |              |
| INDN_12_04    |                     |                |         |              |
| INDN_12_05    |                     |                |         |              |
| INDN_12_06    |                     |                |         |              |

---

## A.7 Observations

*Additional information relevant to the technical content of the PCTR are given here.*

---



---



---



---



---



---



---

---

## Annex B (normative): Partial PIXIT proforma

Notwithstanding the provisions of the copyright clause related to the text of the present document, ETSI grants that users of the present document may freely reproduce the PIXIT proforma in this annex so that it can be used for its intended purposes and may further publish the completed PIXIT.

---

### B.1 Identification summary

PIXIT Number:

---

Test Laboratory Name:

---

Date of Issue:

---

Issued to:

---

---

### B.2 Abstract test suite summary

Protocol Specification: EN 301 068-1

ATS Specification: EN 301 068-6

Abstract Test Method: Multi-party test method (see ISO/IEC 9646-2)

---

### B.3 Test laboratory

Test Laboratory Identification:

---

Accreditation status of the test service:

---

Accreditation reference:

---

Test Laboratory Manager:

---

Test Laboratory contact:

---

Means of Testing:

---



Test Laboratory instructions for Completion:

---

---

## B.4 Client (of the Test Laboratory)

Client Identification:

---

Client Test manager:

---

Client contact:

---

Test Facilities required:

---

---

## B.5 SUT

Name:

---

Version:

---

SCS Reference:

---

Machine configuration:

---

Operating System Identification:

---

IUT Identification:

---

PICS (all layers):

---

---

Limitations of the SUT:

---

Environmental Conditions:

---

## B.6 Protocol information

### B.6.1 Protocol identification

Specification reference: EN 301 068-1

Protocol Version:

PICS Reference:

---

NOTE: The PICS Reference should reference a completed PICS which is conformant with the PICS proforma contained in ETS 300 443-2 and EN 301 068-2.

### B.6.2 Configuration to be tested

**Table B.1: Configuration to be tested**

| Item | Configuration<br>Is the access to be tested ...             | Supported<br>Y/N |
|------|---|------------------|
| 1.1  | releasing layer 2 after entering the Null link state<br>NO? |                  |

### B.6.3 Test management timers

**Table B.2: Timer values**

| Item  | Timer<br>Give a value for the timer that is used ...  | Value<br>(in seconds) |
|-------|---|-----------------------|
| 3.1   | a user side value for T313 (default value 4 seconds).   |                       |
| 3.2   | to wait for the IUT to respond to a stimulus sent by the tester (TAC).  |                       |
| 3.3   | to control that the IUT does not respond to a stimulus sent by the tester (TNOAC).  |                       |
| 3.4   | to wait for the test operator to perform an implicit send action (TWAIT).   |                       |
| NOTE: | The IUT provider may fill in a value range rather than a fixed value for the test management timers. During test execution the test laboratory will choose specific values for the timers dependant on the means of testing used. These specific values may even be beyond the range given by the IUT provider, if this is necessary for achieving satisfactory test results. |                       |

## B.6.4 Parameter Values

**Table B.3: Parameter values**

| Item | Parameter values<br>Give ...  | Value |
|------|---|-------|
| 4.1  | a coding of the Type of number and the Addressing/Numbering plan identification fields of the Called party number information elements to be sent to the IUT.               |       |
| 4.2  | a coding of the number digits of the access related to the PTC1.  |       |
| 4.3  | a coding of the number digits of the access related to the MTC.   |       |
| 4.4  | a coding of a Bearer capability information element, which the IUT is compatible with, for the purpose of accepting incoming calls.   |       |
| 4.5  | a coding of a Bearer capability information element, which the IUT is compatible with, for the purpose of accepting incoming calls with ABR transfer capability.            |       |
| 4.6  | a coding of a Bearer capability information element, which the IUT is compatible with, for the purpose of accepting incoming calls including broadband transfer capability. |       |
| 4.7  | a coding of a Bearer capability information element, which the IUT is incompatible with, for the purpose of accepting incoming calls.                                       |       |
| 4.8  | a coding of the ATM traffic descriptor (octet 5 onwards) to be sent to the IUT.   |       |
| 4.9  | a coding of a compatible ATM traffic descriptor including sustainable cell rate parameter (octet 5 onwards) to be sent to the IUT.  |       |
| 4.10 | a coding of a compatible ATM traffic descriptor including MCR for ABR negotiation (octet 5 onwards) to be sent to the IUT.  |       |
| 4.11 | a coding of a not supported ATM traffic descriptor (octet 5 onwards) to be sent to the IUT.   |       |
| 4.12 | a coding of an compatible ABR setup parameter ie (octet 5 onwards) to be sent to the IUT.   |       |
| 4.13 | a coding of an incompatible ABR setup parameter i.e. (octet 5 onwards) to be sent to the IUT.   |       |
| 4.14 | a coding of a compatible ATM traffic descriptor including RM pcr parameter for ATM block transfer negotiation (octet 5 onwards) to be sent to the IUT.                      |       |
| 4.15 | a value for the preferred VPCI.   |       |
| 4.16 | a value for the preferred VCI.  |       |

---

## Annex C (normative): Abstract Test Suite (ATS)

This ATS has been produced using the Tree and Tabular Combined Notation (TTCN) according to ISO/IEC 9646-3.

The ATS was developed on a separate TTCN software tool and therefore the TTCN tables are not completely referenced in the table of contents. The ATS itself contains a test suite overview part which provides additional information and references.

---

### C.1 The TTCN Graphical form (TTCN.GR)

The TTCN.GR representation of this ATS is contained in an Adobe Portable Document Format™ file (068\_6\_2.PDF contained in archive en\_30106806v010101c0.ZIP) which accompanies the present document.

---

### C.2 The TTCN Machine Processable form (TTCN.MP)

The TTCN.MP representation corresponding to this ATS is contained in an ASCII file (068\_6\_2.MP contained in archive en\_30106806v010101c0.ZIP) which accompanies the present document.

---

## History

| <b>Document history</b> |               |                |                                     |
|-------------------------|---------------|----------------|-------------------------------------|
| V1.1.1                  | December 1999 | Public Enquiry | PE 200017: 1999-12-29 to 2000-04-28 |
|                         |               |                |                                     |
|                         |               |                |                                     |
|                         |               |                |                                     |
|                         |               |                |                                     |