

# ETSI EN 301 021 V1.3.1 (2000-10)

---

*European Standard (Telecommunications series)*

**Fixed Radio Systems;  
Point-to-multipoint equipment;  
Time division Multiple access (TDMA);  
Point-to-Multipoint digital radio systems  
in frequency bands in the range 3 GHz to 11 GHz**

---



---

**Reference**

REN/TM-04085

---

**Keywords**

DRRS, multipoint, radio, TDMA, transmission

**ETSI**

---

650 Route des Lucioles  
F-06921 Sophia Antipolis Cedex - FRANCE

Tel.: +33 4 92 94 42 00 Fax: +33 4 93 65 47 16

Siret N° 348 623 562 00017 - NAF 742 C  
Association à but non lucratif enregistrée à la  
Sous-Préfecture de Grasse (06) N° 7803/88

---

**Important notice**

Individual copies of the present document can be downloaded from:

<http://www.etsi.org>

The present document may be made available in more than one electronic version or in print. In any case of existing or perceived difference in contents between such versions, the reference version is the Portable Document Format (PDF). In case of dispute, the reference shall be the printing on ETSI printers of the PDF version kept on a specific network drive within ETSI Secretariat.

Users of the present document should be aware that the document may be subject to revision or change of status. Information on the current status of this and other ETSI documents is available at <http://www.etsi.org/tb/status/>

If you find errors in the present document, send your comment to:  
editor@etsi.fr

---

**Copyright Notification**

No part may be reproduced except as authorized by written permission.  
The copyright and the foregoing restriction extend to reproduction in all media.

© European Telecommunications Standards Institute 2000.  
All rights reserved.

# Contents

Intellectual Property Rights .....	5
Foreword.....	5
Introduction .....	5
1 Scope .....	7
1.1 Applications .....	7
1.2 Frequencies.....	7
1.3 Access method.....	7
2 References .....	8
3 Symbols and abbreviations.....	10
3.1 Symbols.....	10
3.2 Abbreviations .....	11
4 General system architecture .....	12
4.1 Sub-system types.....	12
4.2 System characteristics .....	13
4.2.1 System capacity .....	13
4.2.2 Transmission error performance .....	13
4.2.3 Round trip delay for speech services .....	13
4.2.4 Transparency.....	14
4.2.5 Synchronization .....	14
5 Radio characteristics.....	14
5.1 Frequency bands.....	14
5.2 Proposed channel arrangement.....	14
5.3 Transmitter (tx) characteristics.....	15
5.3.1 Tx power range .....	15
5.3.2 Automatic Transmit Power Control (ATPC).....	16
5.3.3 Spectrum masks .....	16
5.3.4 Transmitter spurious emissions.....	18
5.3.4.1 Spurious emissions - external.....	18
5.3.4.2 Spurious emissions - internal .....	18
5.3.5 Radio frequency tolerance .....	19
5.4 Receiver characteristics .....	19
5.4.1 Input level range .....	19
5.4.2 Spurious emissions .....	19
5.4.2.1 Spurious emissions - external.....	19
5.4.2.2 Spurious emissions - internal .....	19
5.4.3 Bit Error Rate (BER) performance .....	20
5.4.4 Interference sensitivity.....	20
5.4.4.1 Adjacent channel interference .....	20
5.4.4.2 Co-channel interference .....	21
5.4.4.3 CW interference .....	21
5.4.5 Image frequency rejection .....	21
5.5 Antenna port characteristics .....	21
5.5.1 RF interface .....	21
5.5.2 Return loss .....	21
6 Types of user equipment and service node interfaces .....	22
7 Power supply and environmental characteristics .....	22
7.1 Power supply .....	22
7.2 Environmental conditions.....	23
7.2.1 Equipment within weather protected locations .....	23
7.2.2 Equipment for non-weather protected locations .....	23
7.3 ElectroMagnetic Compatibility (EMC) conditions .....	23

Bibliography .....24  
History .....25

---

## Intellectual Property Rights

IPRs essential or potentially essential to the present document may have been declared to ETSI. The information pertaining to these essential IPRs, if any, is publicly available for **ETSI members and non-members**, and can be found in ETSI SR 000 314: "*Intellectual Property Rights (IPRs); Essential, or potentially Essential, IPRs notified to ETSI in respect of ETSI standards*", which is available from the ETSI Secretariat. Latest updates are available on the ETSI Web server (<http://www.etsi.org/ipr>).

Pursuant to the ETSI IPR Policy, no investigation, including IPR searches, has been carried out by ETSI. No guarantee can be given as to the existence of other IPRs not referenced in ETSI SR 000 314 (or the updates on the ETSI Web server) which are, or may be, or may become, essential to the present document.

---

## Foreword

This European Standard (Telecommunications series) has been produced by ETSI Technical Committee Transmission and Multiplexing (TM).

<b>National transposition dates</b>	
Date of adoption of this EN:	25 August 2000
Date of latest announcement of this EN (doa):	30 November 2000
Date of latest publication of new National Standard or endorsement of this EN (dop/e):	31 May 2001
Date of withdrawal of any conflicting National Standard (dow):	31 May 2001

---

## Introduction

The main field of application of Point-to-Multipoint (P-MP) systems is to provide access to both public and private networks (Public Switched Telephone Networks (PSTN), Private Data Networks (PDN)...). By means of P-MP systems the network service area may be extended to cover both distant and scattered user locations; and the systems may be applied to build new access networks covering both urban and rural areas.

Users are offered the full range of services by the particular public or private network. Users have access to these services by means of the various standardized user network interfaces (2 wire loop, new data services and Integrated Services Digital Network (ISDN) ranging from basic rate to n x primary rate).

P-MP systems provide standard network interfaces and transparently connect users to the appropriate network node. These systems allow a service to be connected to a number of users ranging from a few to several thousands and over a wide range of distances.

P-MP systems are generally configured as Pre-Assigned Multiple Access (PAMA) radio systems or as Demand Assigned Multiple Access (DAMA) radio systems.

The essential features of a typical P-MP radio system are:

- efficient use of the radio spectrum;
- concentration;
- transparency.

Radio is often the ideal way of obtaining communications at low cost and almost independent of distance, and over difficult topography. Moreover, a small number of sites are required for these installations, thus facilitating rapid implementation and minimizing maintenance requirements of the systems.

Concentration means that "m" users can share "n" radio channels (m being larger than n), allowing a better use to be made of the available frequency spectrum and at a lower equipment cost. The term "multi-access" derives from the fact that every user has access to every channel (instead of a fixed assignment as in most multiplex systems). When a demand arises an available channel (or channels) is allocated to it. When the demand is terminated, the channel is released for other use.

Concentration requires the use of distributed intelligent control, which in turn allows many other operation and maintenance functions to be added.

Transparency means that the network node and the user terminal communicate with each other without being aware of the radio path.

Efficient use of the radio spectrum is generally achieved by reusing frequency sets at base stations in a cellular pattern.

---

# 1 Scope

The present document covers equipment, which may operate in frequency bands that have paired frequencies, which can be used by either equipment employing Frequency Division Duplex (FDD) or Time Division Duplex (TDD) techniques. For use with Time Division Duplex only one frequency of the frequency pair will be used and for the purpose of the present document the tx/rx separation will be zero.

## 1.1 Applications

The present document specifies the minimum and optional requirements for system parameters of Time Division Multiple Access (TDMA) Point-to-Multipoint (P-MP) Radio Systems in the terrestrial Fixed Service operating in frequency bands in the range 3 GHz to 11 GHz.

The present document covers the following typical Point-to-Multipoint (P-MP) applications:

- voice;
- fax;
- Voice-band data;
- telex, related to analogue interfaces;
- data up to 64 kbit/s or beyond with optional interfaces;
- ISDN;
- digital video;
- digital audio, related to digital interfaces.

Radio terminals from different manufacturers are not intended to inter-work at radio frequency (i.e. no common air interface).

The present document defines the requirements of radio terminal and radio-relay equipment including the interfaces. The requirements for multiplex, network management and antenna / feeder equipment may be addressed elsewhere.

Testing to the present document will be undertaken with the guidance of a generic test methods document EN 301 126 [19].

## 1.2 Frequencies

The present document covers fixed P-MP services operating in the 3,5 GHz, 3,7 GHz and 10,5 GHz bands, having the frequency plans as given in ERC Recommendations 14-03 [7], 12-08 [20], 12-05 [8], and in ITU-R Recommendation F.1189 [29].

## 1.3 Access method

The present document covers Time Division Multiple Access (TDMA) systems.

---

## 2 References

The following documents contain provisions, which, through reference in this text, constitute provisions of the present document.

- References are either specific (identified by date of publication, edition number, version number, etc.) or non-specific.
- For a specific reference, subsequent revisions do not apply.
- For a non-specific reference, the latest version applies.
- A non-specific reference to an ETS shall also be taken to refer to later versions published as an EN with the same number.

- [1] ETSI ETS 300 012 (1992): "Integrated Services Digital Network (ISDN); Basic user-network interface Layer 1 specification and test principles".
- [2] ITU-T Recommendation G.703: "Physical/electrical characteristics of hierarchical digital interfaces".
- [3] ITU-T Recommendation Q.553 (1994): "Transmission characteristics at 4-wire analogue interfaces of digital exchanges".
- [4] ITU-T Recommendation Q.552 (1994): "Transmission characteristics at 2-wire analogue interfaces of digital exchanges".
- [5] ITU-T Recommendation G.821: "Error performance of an international digital connection operating at a bit rate below the primary rate and forming part of an integrated services digital network".
- [6] ITU-T Recommendation R.20: "Telegraph modem for subscriber lines".
- [7] ERC Recommendation 14-03: "Harmonized radio frequency channel arrangements for low and medium capacity systems in the band 3 400 MHz to 3 600 MHz".
- [8] ERC Recommendation 12-05: "Harmonized radio frequency channel arrangements for digital terrestrial fixed systems operating in the band 10.0 - 10.68 GHz".
- [9] ETSI ETS 300 019, Parts 1 and 2 (1994): "Equipment Engineering (EE); Environmental conditions and environmental tests for telecommunications equipment; sub-parts 1-1 to 1-7: Classification of environmental conditions; sub-parts 2-1 to 2-7: Specification of environmental tests".
- [10] ETSI ETS 300 132: "Equipment Engineering (EE); Power supply interface at the input to telecommunications equipment; Part 1: Operated by alternating current (ac) derived from direct current sources; and Part 2: Operated by direct current (dc)".
- [11] ETSI EN 300 385: "Electromagnetic compatibility and Radio spectrum Matters (ERM); ElectroMagnetic Compatibility (EMC) standard for fixed radio links and ancillary equipment".
- [12] ITU-T Recommendation G.726: "40, 32, 24, 16 kbit/s Adaptive Differential Pulse Code Modulation (ADPCM)".
- [13] ITU-T Recommendation G.728: "Coding of speech at 16 kbit/s using low-delay code excited linear prediction".
- [14] ITU-R Recommendation F.697-1: "Error performance and availability objectives for the local-grade portion at each end of an ISDN connection utilizing digital radio-relay systems".
- [15] ITU-T Recommendation G.729: "Coding of speech at 8 kbit/s using conjugate-structure algebraic-code-excited linear-prediction".



- [16] ETSI EN 300 324: "V interfaces at the digital Local Exchange (LE); V5.1 interfaces for the support of Access Network (AN)".
- Part 1: "V5.1 interface specification";
- Part 2: "Protocol Implementation Conformance Statement (PICS) proforma specification";
- Part 3: "Test Suite Structure and Test Purposes (TSS&TP) specification for the network layer (AN side)";
- Part 4: "Abstract Test Suite (ATS) and partial Protocol Implementation eXtra Information for Testing (PIXIT) proforma specification for the network layer (AN side)";
- Part 5: "Test Suite Structure and Test Purposes (TSS&TP) specification for the network layer (LE side)";
- Part 6: "Abstract Test Suite (ATS) and partial Protocol Implementation eXtra Information for Testing (PIXIT) proforma specification for the network layer (LE side)";
- Part 7: "Test Suite Structure and Test Purposes (TSS&TP) specification for the data link layer";
- Part 8: "Abstract Test Suite (ATS) and partial Protocol Implementation eXtra Information for Testing (PIXIT) proforma specification for the data link layer";
- Part 9: "Test specification for the physical layer".
- [17] ETSI ETS 300 347: "Signalling Protocols and Switching (SPS); V interfaces at the digital Local Exchange (LE) V5.2 interface for the support of Access Network (AN)".
- Part 1: "V5.2 interface specification";
- Part 2: "Protocol Implementation Conformance Statement (PICS) proforma specification";
- Part 3: "Test Suite Structure and Test Purposes (TSS&TP) specification for the network layer (AN side)";
- Part 4: "Abstract Test Suite (ATS) and partial Protocol Implementation eXtraInformation for Testing (PIXIT) proforma specification for the network layer (AN side)";
- Part 5: "Test Suite Structure and Test Purposes (TSS&TP) specification for the network layer (LE side)";
- Part 6: "Abstract Test Suite (ATS) and partial Protocol Implementation eXtra Information for Testing (PIXIT) proforma specification for the network layer";
- Part 7: "Test Suite Structure and Test Purposes (TSS&TP) specification for the data link layer";
- Part 8: "Abstract Test Suite (ATS) and partial Protocol Implementation eXtra Information for Testing (PIXIT) proforma specification for the data link layer";
- Part 9: "Test specification for the physical layer".
- [18] ITU-R Recommendation F.1191: "Bandwidths and unwanted emissions of digital radio-relay systems".
- [19] ETSI EN 301 126: "Fixed Radio Systems; Conformance testing".
- Part 2-1: "Point-to-Multipoint equipment - Definitions and general requirements";
- Part 2-3: "Point-to-Multipoint equipment - Test procedures for TDMA systems";
- Part 3-2: "Point-to-Multipoint antennas - Definitions, general requirements and test procedures".
- [20] ERC Recommendation 12-08: "Harmonized radio frequency channel arrangements and blocks allocations for medium and high capacity systems in the band 3 600 MHz to 4 200 MHz".
- [21] ITU-T Recommendation G.131: "Control of talker echo".

- [22] ETSI EN 300 011: "Integrated Services Digital Network (ISDN); Primary rate User-Network Interface (UNI); Part 1: Layer 1 specification".
- [23] ISO/IEC 8802-3: "Information technology - Telecommunications and information exchange between systems - Local and metropolitan area networks - Specific requirements - Part 3: Carrier sense multiple access with collision detection (CSMA / CD) access method and physical layer specifications".
- [24] CEPT/ERC Recommendation 74-01: "Spurious emissions".
- [25] ITU-R Recommendation SM.329-7: "Spurious emissions".
- [26] ITU-R Draft New Recommendation ITU-R.F [Doc 9B/100] on Frequency Block Arrangements for Fixed Wireless Access (FWA) Systems in the Range 3400-3800 MHz. ITU Document 9B/TEMP/79 [Rev1] April 1999 (see note).
- [27] ITU-T Recommendation G.826: "Error performance parameters and objectives for international, constant bit rate digital paths at or above the primary rate".
- [28] ITU-T Recommendation G.827: "Availability parameters and objectives for path elements of international constant bit rate digital paths at or above the primary rate".
- [29] ITU-R Recommendation F.1189: "Error performance objectives for constant bit rate digital path at or above the primary rate carried by digital radio-relay systems which may form part or all of the national portion of a 27 500 km hypothetical reference path".
- [30] ITU-R Recommendation F.557: "Availability objective for radio-relay systems over a hypothetical reference circuit and a hypothetical reference digital path".
- [31] ITU-T Recommendation G.723: "Dual rate speech coder for multimedia communications transmitting at 5.3 and 6.3 kbit/s".
- [32] ETSI EG 202 306 (V1.2): "Transmission and Multiplexing (TM); Access networks for residential customers".
- [33] ITU-T Recommendation G.711: "Pulse Code Modulation (PCM) of voice frequencies".
- [34] ITU-T Recommendation G.957: "Optical interfaces for equipments and systems relating to the synchronous digital hierarchy".
- [35] ITU-R Radio Regulations S5.482, Geneva.

NOTE: At the time, the present document is due to proceed to the ETSI European Norm One-Step Approval Procedure, this document is not publicly available. The reference will be update before publication.

---

## 3 Symbols and abbreviations

### 3.1 Symbols

For the purposes of the present document, the following symbols apply:

Hz	Hertz
kHz	kiloHertz
MHz	MegaHertz
GHz	GigaHertz
kbit/s	kilobits per second
Mbit/s	Megabits per second
ms	millisecond
dB	deciBel
dBm	deciBel relative to 1 milliwatt

## 3.2 Abbreviations

For the purposes of the present document, the following abbreviations apply:

BER	Bit Error Rate
BWe	evaluation Bandwidth
BWr	reference Bandwidth
CCS	Central Controller Station
CS	Central Station
CRS	Central Radio Station
EMC	Electromagnetic Compatibility
ERC	European Radiocommunications Committee
ISDN	Integrated Services Digital Network
PRBS	Pseudo-Random Binary Sequence
RS	Repeater Station
TDMA	Time Division Multiple Access
TMN	Telecommunications Management Network
TS	Terminal Station
LD CELP	Low Delay Code Excited Linear Prediction
MOS	Mean Opinion Score
QDU	Quantization Distortion Unit
TSH	Terminal Station High frequency
TSL	Terminal Station Low frequency
RS	Repeater Station
RSC	Repeater Station Crossband
rx	Receiver
TE	Terminal Equipment
tx	Transmitter

## 4 General system architecture

### 4.1 Sub-system types

A system could consist of several sub-systems as follows (see Figure 1):

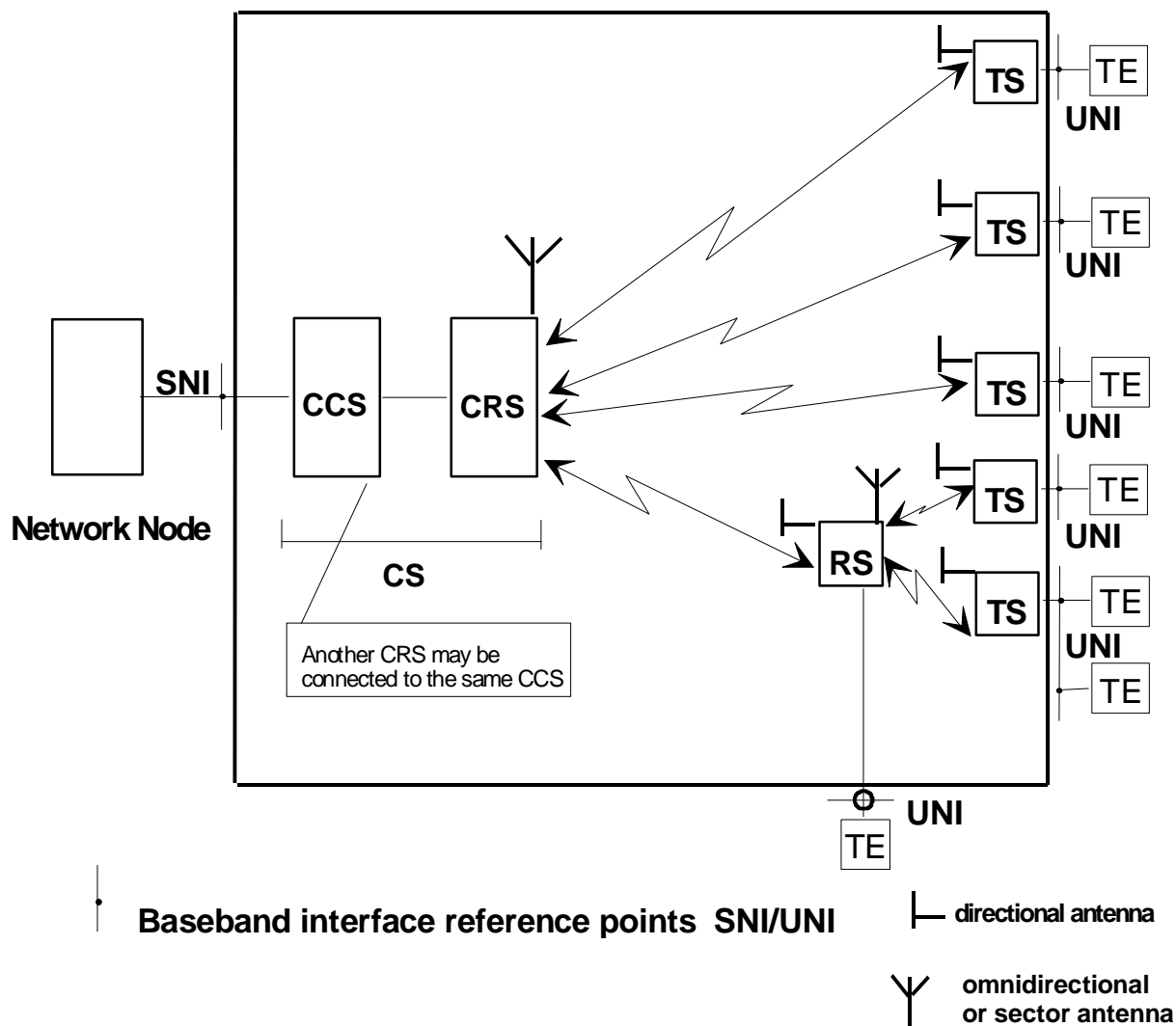

Figure 1: General system architecture

**CS:** The Central Station, which interfaces the network. It can be integrated or divided into two units:

- the Central Controller Station (CCS) also called the exchange unit which is the interface to the local switch;
- the Central Radio Station (CRS) also called the radio unit, which is the central baseband/radio transceiver equipment. One CCS may control more than one CRS.

**TS:** The Terminal Station (outstations with subscriber interfaces). A TS may serve more than one Terminal Equipment (TE).

**RS:** The Repeater Station (radio repeater outstations with or without subscriber interfaces). An RS may serve one or more TS.

**SNI:** Service Node Interface (EG 202 306 [32]).

**UNI:** User Network Interface (EG 202 306 [32]).

The central station performs the interconnection with the network node carrying out a concentration function by sharing the total number of available channels in the system. The central station is linked either directly to all Terminal Stations or via Repeater Stations (RS) by microwave transmission paths. Whenever an existing digital transmission link is available, separating the CCS installed at the network node site and the CRS can optimize the network implementation.

The general characteristics, which are typical for P-MP systems, are considered in the present document. These characteristics have been categories under four headings:

- 1) system characteristics;
- 2) radio characteristics;
- 3) type of services/user equipment and network interfaces;
- 4) power supply, mechanical and environmental characteristics.

## 4.2 System characteristics

The following characteristics shall be used:

### 4.2.1 System capacity

The present document defines four System Types A, B C and D. These systems represent:

- A: lower capacity type;
- B: medium capacity type;
- C: lower capacity systems with a gross bit rate below 2 Mb/s and limited to TDD operation only;
- D: higher capacity systems.

The minimum gross bit rates for different channel spacing and system types are given in Table 2. The gross bit rate is defined as the transmission bit rate over the air. In case of a transmitter working in burst mode the gross bit rate is the instantaneous maximum transmission bit rate during the burst. The gross bit rate has an unique relation to the symbol rate through the implemented modulation format.

The actual system traffic carrying capacity, the gross bit rate and the manufacturer shall declare the System Type.

### 4.2.2 Transmission error performance

Equipment with system rate lower than 32x64 kbit/s or equivalent, shall be designed in order to meet network performance and availability requirements specified by ITU-T Recommendation G.821 [5] following the criteria defined in ITU-R Recommendation F.697-1 [14] for the local grade portion of the digital connection.

Equipment with system rate equal or higher than 32x64 kbit/s or equivalent, shall be designed in order to meet network performance and availability requirements foreseen by ITU-T Recommendations G.826 [27] and G.827 [28] following the criteria defined in ITU-R Recommendations F.1189 [29] and F.557 [30] for the national portion of the digital connection.

### 4.2.3 Round trip delay for speech services

The round trip delay for a 64 kbit/s traffic channel shall not exceed 20 ms.

Longer round trip delays may result at other bit rates and when using speech coding at rates lower than 64 kbit/s. In order to guarantee that the delay introduced by the system into the transmission network does not degrade the quality of the telephone communication, compliance with ITU-T Recommendation G.131 [21] shall be ensured.

## 4.2.4 Transparency

The system shall be fully transparent: the network node and the user equipment (points SNI and UNI in the Reference Model, Figure 1) communicate with each other without being aware of the radio link. The system shall be transparent to analogue or digital subscriber equipment signalling and to voiceband data signals. However, advantage may be taken of coding methods at rates lower than 64 kbit/s to conserve radio spectrum, provided that a means to maintain the above transparency is used.

At least one of the following standard coding methods could be employed:

- 64 kbit/s: according to ITU-T Recommendation G.711 [33], which will provide full transparency and permit a direct digital interface to digital switches;
- 32 kbit/s: according to ITU-T Recommendation G.726 [12];
- 16 kbit/s: according to ITU-T Recommendation G.728 [13] for Low Delay Code Excited Linear Prediction (LD CELP);
- 8 kbit/s: according to ITU-T Recommendation G.729 [15];
- 6.3 kbit/s: according to ITU-T Recommendation G.723 [31].

Other voice coding methods may be employed if the quality (measured for example in Quantization Distortion Units (QDU) or Mean Opinion Score (MOS)) shall be equivalent to the above.

## 4.2.5 Synchronization

Systems employing digital interfaces shall include methods enabling internal and external synchronization to the network. Synchronization tolerance should meet the requirements of ITU-T Recommendation G.703 [2].

# 5 Radio characteristics

## 5.1 Frequency bands

Bands allocated to the fixed service in the range 3 GHz to 11 GHz shall be used.

## 5.2 Proposed channel arrangement

Table 1 gives details of proposed bands and Table 2 channel spacing, which have been considered within CEPT, the European Radiocommunications Committee (ERC) and ITU-R.

**Table 1: Frequency bands**

Frequency band	Band limits	Transmit/receive spacing (applies to channels/blocks)
3,5 GHz	3,4 GHz to 3,6 GHz	50 MHz or 100 MHz, ERC Recommendation 14-03 [7] ITU-R Recommendation 9B/TEMP/79[Rev1]-E [26]
3,7 GHz	3,6 GHz to 3,8 GHz	50 MHz or 100 MHz ERC Recommendation 12-08 [20] ITU-R Recommendation 9B/TEMP/79[Rev1]-E [26]
10,5 GHz	10,15 GHz to 10,3 GHz paired with 10,5 GHz to 10,65 GHz	350 MHz, ERC Recommendation 12-05 [8]
NOTE: Administrations may assign further parts of Fixed Service bands in the range 3 to 11 GHz to systems defined in the present document in accordance with appropriate CEPT Recommendations. When applied to TDD equipment, references in the present document to tx/rx separation should be disregarded.		

Table 2: Channel spacing/minimum gross bit rate

Channel spacing (MHz)	<1,75 (note)	1,75/2	3,5	7	14	28/30
<b>System Type A</b>						
Minimum gross bit rate (Mbit/s)	<2	2	4	8	16	32
<b>System Type B</b>						
Minimum gross bit rate (Mbit/s)	<4	4	8	16	32	64
<b>System Type C</b>						
Minimum gross bit rate (Mbit/s)	<2	NA	NA	NA	NA	NA
<b>System Type D</b>						
Minimum gross bit rate (Mbit/s)		<u>6</u>	<u>12</u>	<u>24</u>	<u>48</u>	<u>96</u>

NOTE: See note of Table 3.

## 5.3 Transmitter (tx) characteristics

### 5.3.1 Tx power range

The maximum value of output power, referred to point C' of the RF block diagram in Figure 2 shall not exceed 35 dBm.

ITU-R Radio Regulations S5.482 [35] states that in the band 10,6 to 10,68 GHz, stations of the Fixed and Mobile, except Aeronautical Mobile, services shall be limited to a maximum equivalent isotropically radiated power of 40 dBW and the power delivered to the antenna shall not exceed -3 dBW.

If for proper operation of the system or for regulatory purposes, a reduced range of output power is required, then a built in or added means of adjustment shall be provided.

The tolerance value around the nominal or selected value of output power is  $\pm 1$  dB.

The transmitted output power means the value measured when the output is connected to a dummy load, i.e. power meter or spectrum analyser. The transmitted carrier shall be modulated with a signal representing the normal traffic, under all conditions of loading and services.

Two different measurement methods can be used:

- 1) spectrum analyser with resolution bandwidth and video bandwidth greater than 1 MHz; or
- 2) power meter.

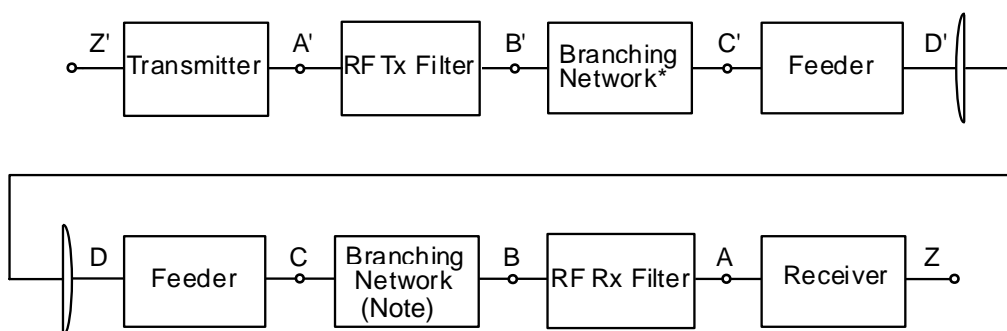

NOTE: Points B and C and B' and C' will coincide if branching networks are not used.

Figure 2: Radio Frequency (RF) block diagram

### 5.3.2 Automatic Transmit Power Control (ATPC)

ATPC is considered to be an optional feature. Equipment with ATPC will be subject to manufacturer declaration of the ATPC ranges and related tolerances. Testing shall be carried out with output power level corresponding to:

- ATPC set manually to a fixed value for system performance;
- ATPC set at the nominal output power declared by the manufacturer.

### 5.3.3 Spectrum masks

Spectrum masks are given in Figure 3.

The transmitted output power spectrum is defined as: the spectrum when modulated with a signal representing the normal traffic, under all conditions of loading and services.

The spectrum measurement at point C' of the system block diagram shall be performed with the "maximum hold" function selected on the spectrum analyser.

The reference level of the output spectrum means that the 0 dB level is the top of the modulated spectrum.

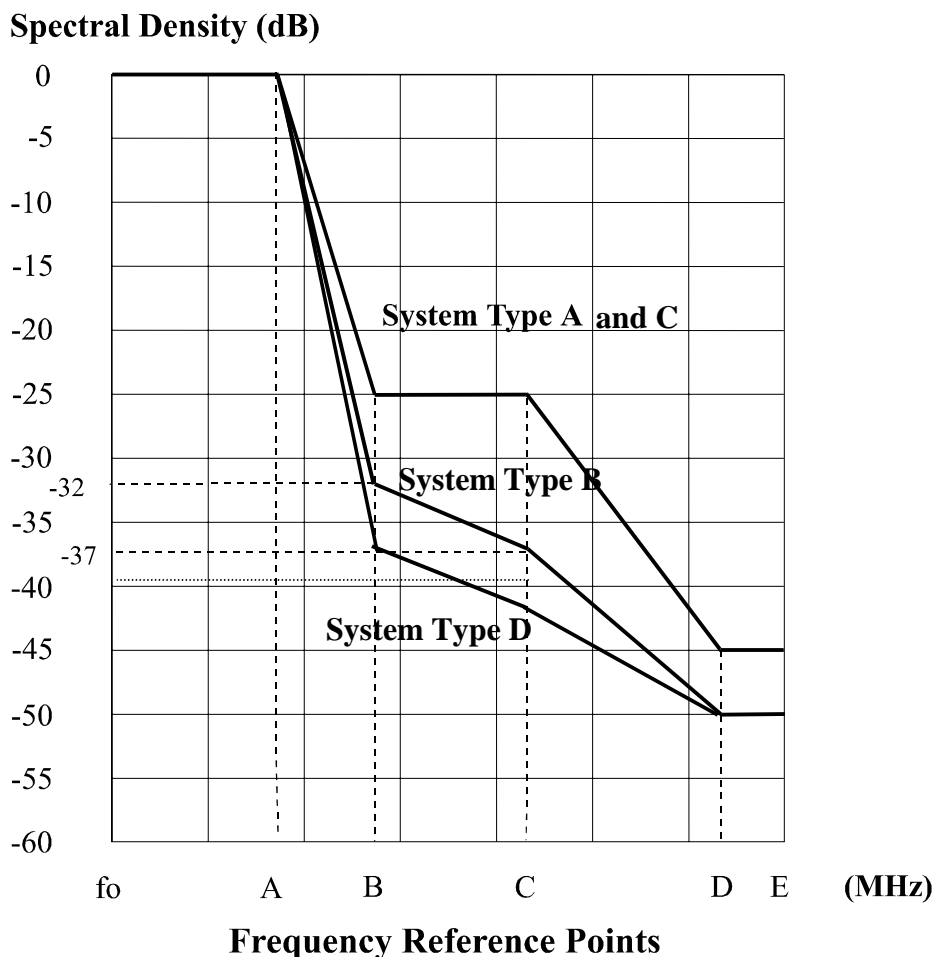

Figure 3: Power spectrum masks ( $f_0$  = actual carrier frequency)



Table 3: Reference frequencies for spectrum masks

		Frequency offset (MHz)				
<b>System Type A</b>						
Channel spacing, (MHz)	Minimum gross bit rate (Mbit/s)	A	B	C	D	E
(note)	<2	1,7 x Symbol Rate (Mbaud)	2,6 x Symbol Rate (Mbaud)	3,6 x Symbol Rate (Mbaud)	6,4 x Symbol Rate (Mbaud)	10 x Symbol Rate (Mbaud)
1,75	2	0,75	1,15	1,6	2,8	4,375
2	2	0,85	1,3	1,8	3,2	5,0
3,5	4	1,5	2,5	3,7	6,8	8,75
7	8	2,8	5,6	7	14	17,5
14	16	5,6	11,2	14	28	35
28/30	32	11,2	22,4	28	56	70
NOTE: TDMA systems with minimum gross bit rates <2 Mbit/s for system type A and C or <4 Mbit/s for system type B may use various channel spacing within blocks of slots assigned to an operator according to ERC Recommendations 14-03 [7], 12-05 [8] or 12-08 [20]. The manufacturer shall declare the symbol rate and channel spacing, from which the break points A, B, C and D for the spectrum mask can be calculated.						
<b>System Type B</b>						
Channel spacing, (MHz)	Minimum gross bit rate (Mbit/s)	A	B	C	D	E
(note)	<4	1,7 x Symbol Rate (Mbaud)	2,6 x Symbol Rate (Mbaud)	3,6 x Symbol Rate (Mbaud)	6,4 x Symbol Rate (Mbaud)	10 x Symbol Rate (Mbaud)
1,75	4	0,8	1,4	1,85	3,5	4,375
3,5	8	1,5	2,5	3,7	7,0	8,75
7	16	2,8	5,6	7	14	17,5
14	32	5,6	11,2	14	28	35
28/30	64	11,2	22,4	28	56	70
<b>System Type C</b>						
Channel spacing, (MHz)	Minimum gross bit rate (Mbit/s)	A	B	C	D	E
(note)	<2	1,7 x Symbol Rate (Mbaud)	2,6 x Symbol Rate (Mbaud)	3,6 x Symbol Rate (Mbaud)	6,4 x Symbol Rate (Mbaud)	10 x Symbol Rate (Mbaud)
<b>System Type D</b>						
Channel spacing, (MHz)	Minimum gross bit rate (Mbit/s)	A	B	C	D	E
1,75	6	0,8	1,4	1,85	3,5	4,375
2	6,5	0,85	1,6	2	4	5
3,5	12	1,5	2,9	3,7	7,0	8,75
7	24	2,8	5,6	7	14	17,5
14	48	5,6	11,2	14	28	35
28/30	96	11,2	22,4	28	56	70

Table 4: Spectrum analyser settings for RF power spectrum measurement for CRS only

RF channel spacing. (MHz)	<1,75	3,5	7	14	28/30
Centre frequency	actual	actual	actual	actual	actual
Sweep width (MHz)	20	20	40	80	160
Scan time	auto	auto	auto	auto	auto
IF bandwidth (kHz)	30	30	30	30	100
Video bandwidth (kHz)	0,1	0,1	0,3	0,3	0,3
NOTE 1: The Spectrum Analyser Settings for RF Power Spectrum Measurement for Terminal Stations are dependent on the burst duration. For a burst duration of ca. 50µs, the recommended settings are: IF bandwidth=ca. 30 kHz and video bandwidth=ca. 3 kHz.					
NOTE 2: For other pulse durations, the recommended settings are as follows: - IF bandwidth=ca. 30 kHz x 50µs/(pulse duration in µs); - Video bandwidth=ca. 3 kHz x 50µs/(pulse duration in µs).					
NOTE 3: The manufacturer shall declare the pulse duration and agree the spectrum analyser settings with the administration concerned.					

### 5.3.4 Transmitter spurious emissions

It is necessary to define spurious emissions from transmitters for two reasons:

- a) to limit interference into other systems operating wholly externally to the system under consideration (external emissions), which limits are specified by CEPT/ERC Recommendation 74-01 [24] based on ITU R Recommendations SM.329-7 [25], and ITU-R Recommendation F.1191 [18].
- b) to limit local interference within the system where transmitters and receivers are directly connected via the filter and branching systems (internal emissions).

This may lead to two sets of spurious emission limits at reference point B' for indoor systems and C' for outdoor systems (or where a common tx/rx duplexer is used).

#### 5.3.4.1 Spurious emissions - external

According to CEPT/ERC Recommendation 74-01 [24] the external spurious emissions are defined as emissions at frequencies, which are separated from the nominal carrier frequency more than  $\pm 250\%$  of the relevant channel separation.

Outside the band of  $\pm 250\%$  of the relevant channel separation, the Fixed Service radio systems spurious emission limits, defined by CEPT/ERC Recommendation 74-01 [24] together with the frequency range to consider for conformance measurement, shall apply.

#### 5.3.4.2 Spurious emissions - internal

Internal spurious emissions are not relevant.

### 5.3.5 Radio frequency tolerance

Maximum radio frequency tolerance shall not exceed the values defined in Table 5. These limits include both short-term factors (environmental effects) and long term ageing effects.

In the type test the manufacturer shall state the guaranteed short-term part and the expected ageing part.

**Table 5: Permitted frequency tolerance**

Frequency band (GHz)	Minimum gross bit rate (Mbit/s)	Frequency tolerance (kHz)
3,5/3,7	<0,5	±4
3,5/3,7	0,5 to<2,0	±50
3,5/3,7	≥2	±60
10,5	<2,0	±150
10,5	≥2	±220
NOTE: in frequency bands not covered by Table 5, the radio frequency tolerance shall be ≤±20ppm.		

The equipment should be designed, manufactured, and maintained to ensure that the long-term frequency tolerance remains within the limits above.

## 5.4 Receiver characteristics

### 5.4.1 Input level range

The input level range shall be greater than 40 dB above the threshold level for a BER of  $10^{-3}$  referred to point C of the system block diagram (Figure 2).

### 5.4.2 Spurious emissions

See subclause 5.3.4.

#### 5.4.2.1 Spurious emissions - external

The limit values measured at reference point C of CEPT/ERC recommendation 74-01 [24] shall apply.

#### 5.4.2.2 Spurious emissions - internal

Internal spurious emissions are not relevant.

### 5.4.3 Bit Error Rate (BER) performance

BER, measured at the user interfaces, versus receive signal power level, referred to point C of the system block diagram (Figure 2) shall be equal to or better than the values in Table 6.

**Table 6: BER versus receiver signal level**

Channel spacing (MHz)	Minimum gross bit rate (Mbit/s)	BER 10 <sup>-3</sup> (dBm)	BER 10 <sup>-6</sup> (dBm)
<b>System Type A</b>			
Note 2	< 2	(Note 1)	(Note 1)
1,75/2 MHz	2	-90	-86
3,5 MHz	4	-87	-83
7,0 MHz	8	-84	-80
14,0 MHz	16	-81	-77
28/30 MHz	32	-78	-74
<b>System Type B</b>			
Note 2	<4	(Note 1)	(Note 1)
1,75/2 MHz	4	-82	-78
3,5 MHz	8	-79	-75
7,0 MHz	16	-76	-72
14 MHz	32	-73	-69
28/30 MHz	64	-70	-66
<b>System Type C</b>			
Note 2	< 2	(Note 1)	(Note 1)
<b>System Type D</b>			
1,75 /2 MHz	6	-76	-72
3,5MHz	12	-73	-69
7,0MHz	24	-70	-66
14,0MHz	48	-67	-63
28/30MHz	96	-64	-60
<p>NOTE 1: For bit rates below 2,0 Mbit/s the reference levels for System Type A shall be calculated from the following formulas:            For BER=10<sup>-3</sup>: <math>(-93+10\log_{10}[\text{gross bit rate Mbit/s}])</math> dBm;            For BER=10<sup>-6</sup>: <math>(-89+10\log_{10}[\text{gross bit rate Mbit/s}])</math> dBm.</p> <p>For bit rates below 2,0 Mbit/s for System Type C, and below 4,0 Mbit/s for System type B the reference levels shall be calculated from the following formulas:            For BER=10<sup>-3</sup>: <math>(-85+10\log_{10}[\text{gross bit rate Mbit/s}])</math> dBm;            For BER=10<sup>-6</sup>: <math>(-81+10\log_{10}[\text{gross bit rate Mbit/s}])</math> dBm.</p>			
NOTE 2: See note of Table 3.			

### 5.4.4 Interference sensitivity

#### 5.4.4.1 Adjacent channel interference

Adjacent channel sensitivity is defined as the ability of the receiver to receive a wanted signal in the presence of a like unwanted signal, which is one channel away.

The two signal generators shall be connected to the receiver input via a combiner, so that the impedance is matched to the nominal impedance.

The wanted signal shall be tuned to the receiver's nominal frequency and be modulated with a Pseudo-Random Binary Sequence (PRBS) signal. The interfering signal shall be turned off while the wanted signal is adjusted to the level corresponding to BER=10<sup>-6</sup> as specified in Table 6.

The interfering signal shall be tuned one channel away from the wanted signal and be modulated with a PRBS signal, which is uncorrelated to the wanted signal.

The interfering signal shall be adjusted to the same level as the wanted signal. The BER shall not be greater than  $10^{-5}$ .

Measurement on both sides of the nominal frequency shall be carried out.

#### 5.4.4.2 Co-channel interference

Co-channel sensitivity is defined as the ability of the receiver to receive a wanted signal in the presence of a like unwanted signal on the same frequency.

The two signal generators shall be connected to the receiver input via a combiner, so that the impedance is in matched to the nominal impedance of the system.

The wanted signal shall be tuned to the receiver's nominal frequency and modulated with a PRBS signal.

The interfering signal shall be turned off while the wanted signal is adjusted to the level corresponding to  $BER=10^{-6}$  as specified in Table 6.

The interfering signal shall be tuned to the same frequency as the wanted signal and modulated with a PRBS signal, which is uncorrelated to the wanted signal.

The interfering signal shall then be injected at a level, which is 23 dB for System Type A and C, 30 dB for System Type B and 37 dB for System Type D below the wanted signal.

The BER shall not be greater than  $10^{-5}$ .

#### 5.4.4.3 CW interference

For a receiver operating at the RSL specified in subclause 5.4.3 for  $10^{-6}$  BER threshold, the introduction of a CW interferer at a level of +30 dB with respect to the wanted signal and at any frequency up to five times the carrier center frequency, excluding frequencies on either side of the centre frequency of the wanted RF channel by up to 500% of the co-polar channel spacing, shall not cause a degradation of more than 1 dB of the BER threshold as specified in subclause 5.4.3 (Table 6).

The CW Interference level is under discussion within TM4. Nevertheless the above stated CW Interference specification should be applied till the final specification will be released.

### 5.4.5 Image frequency rejection

If applicable image frequency (frequencies) rejection shall be greater than 75 dB.

## 5.5 Antenna port characteristics

### 5.5.1 RF interface

The RF interface at reference points C and C' of the system block diagram (Figure 2) is to be declared by the manufacturer.

### 5.5.2 Return loss

For equipment without an integral antenna, the return loss at reference points C and C' of the RF system block diagram (Figure 2) shall be more than 10 dB at the reference impedance.

## 6 Types of user equipment and service node interfaces

Table 7 lists a range of interfaces for various voice and data services. At least one of these interfaces shall be implemented in a P-MP system covered by the present document.

**Table 7: Types of interfaces**

<b>User Network Interfaces</b>	
Analogue (2 wires)	ITU-T Recommendation Q.552 [4].
Analogue (4 W + E & M)	ITU-T Recommendation Q.553 [3].
Telex	ITU-T Recommendation R.20 [6]; plus the V series of ITU-T Recommendations.
Digital data port	ITU-T Recommendation G.703 [2]; the H series, the V series, and the X series of ITU-T Recommendations.
ISDN basic rate	ETS 300 012 [1] (note 1).
ISDN primary rate	EN 300 011 [22]
CSMA/CD Ethernet interface	ISO/IEC 8802-3 [23]
<b>Service Node Interfaces</b>	
2 Mbit/s	ITU-T Recommendation G.703 [2].
Analogue (2 wires)	ITU-T Recommendation Q.552 [4].
Analogue (4 W + E & M)	ITU-T Recommendation Q.553 [3].
Telex	ITU-T Recommendation R.20 [6]; the V series of ITU-T recommendations.
Digital data port	ITU-T Recommendation G.703 [2]; the H series, the V series, and the X series of ITU-T Recommendations.
ISDN basic rate	ETS 300 012 [1] (note 2).
ISDN primary rate	EN 300 011 [22]
Digital data port (optical)	ITU-T Recommendation G.957 [34]
ISDN + analogue subscribers + leased lines 2 Mbit/s interface	V5.1: EN 300 324 [16]; V5.2: ETS 300 347 [17]); ITU-T Recommendation G.703 [2].
CSMA/CD Ethernet interface	ISO/IEC 8802-3 [23]
NOTE 1: ETS 300 012 [1] defines the S ISDN interface which is a customer premises interface and may not be suitable as a terminal station interface.	
NOTE 2: As noted above, ETS 300 012 [1] is a customer premises interface and may not be suitable as a network interface. However, exchange line interfaces for ISDN basic rate are to be vendor - specific and no single standard interface is available.	

## 7 Power supply and environmental characteristics

### 7.1 Power supply

The equipment shall operate from one or more of the power supplies within the ranges specified in Tables 8 and 9. The power supply interface shall be in accordance with the characteristics of one or more of the secondary voltages foreseen in ETS 300 132 [10].

**Table 8: Power supplies - DC**

<b>Nominal voltage</b>	<b>Voltage range</b>
12 V	10,8 V to 13,6 V
24 V	21,8 V to 28,1 V
48 V	40,5 V to 57 V (see ETS 300 132 [10])
60 V	50,0 V to 72 V (see ETS 300 132 [10])

**Table 9: Power supplies - AC**

For 110 V AC nominal	99 V to 121 V	60 Hz±2 Hz
For 230 V AC nominal	207 V to 253 V	50 Hz±2 Hz (see ETS 300 132 [10])

## 7.2 Environmental conditions

The equipment shall meet the environmental conditions set out in ETS 300 019 [9] which defines weather protected and non-weather protected locations classes and test severities.

### 7.2.1 Equipment within weather protected locations

Equipment intended for operation in temperature controlled locations or partially temperature controlled locations shall meet the requirements of ETS 300 019 [9] classes 3.1 and 3.2 respectively.

Optionally, the more stringent requirements of ETS 300 019 [9] classes 3.3 (non temperature controlled locations), 3.4 (sites with heat trap) and 3.5 (sheltered locations) may be applied.

### 7.2.2 Equipment for non-weather protected locations

Equipment intended for operation in non-weather protected locations shall meet the requirements of ETS 300 019 [9], class 4.1 or 4.1E.

Class 4.1 applies to many European countries and class 4.1E applies to all European countries.

Weather protected equipment conforming to classes 3.3, 3.4 and 3.5 together with an enclosure or cabinet may fulfil the requirements for operating in a non-weather protected environment but this is outside the scope of the present document.

## 7.3 ElectroMagnetic Compatibility (EMC) conditions

For those aspects of EMC not specified in the present document, the conditions of EN 300 385 [11] shall apply.

---

## Bibliography

The following material, though not specifically referenced in the body of the present document (or not publicly available), gives supporting information.

- ITU-T Recommendation G.773 (1993): "Protocol suites for Q-interfaces for management of transmission systems".



---

## History

<b>Document history</b>		
V1.1.1	July 1998	Publication
V1.2.1	May 2000	Publication
V1.3.1	April 2000	One-step Approval Procedure      OAP 20000825: 2000-04-26 to 2000-08-25
V1.3.1	September 2000	Publication