

EN 300 945 V6.0.1 (1999-09)

European Standard (Telecommunications series)

**Digital cellular telecommunications system (Phase 2+);
Rate adaption on the Mobile Station - Base Station System
(MS - BSS) Interface
(GSM 04.21 version 6.0.1 Release 1997)**



GSM®
GLOBAL SYSTEM FOR
MOBILE COMMUNICATIONS

ETSI 

Reference

DEN/SMG-040421Q6 (8r00300o.PDF)

Keywords

Digital cellular telecommunications system,
Global System for Mobile communications (GSM)

ETSI

Postal address

F-06921 Sophia Antipolis Cedex - FRANCE

Office address

650 Route des Lucioles - Sophia Antipolis
Valbonne - FRANCE
Tel.: +33 4 92 94 42 00 Fax: +33 4 93 65 47 16
Siret N° 348 623 562 00017 - NAF 742 C
Association à but non lucratif enregistrée à la
Sous-Préfecture de Grasse (06) N° 7803/88

Internet

secretariat@etsi.fr
Individual copies of this ETSI deliverable
can be downloaded from
<http://www.etsi.org>
If you find errors in the present document, send your
comment to: editor@etsi.fr

Copyright Notification

No part may be reproduced except as authorized by written permission.
The copyright and the foregoing restriction extend to reproduction in all media.

© European Telecommunications Standards Institute 1999.
All rights reserved.

Contents

Intellectual Property Rights.....	5
Foreword	5
1 Scope.....	6
2 References.....	6
2.1 Abbreviations and definitions	7
3 General approach	7
3.1 Overview of the multislot data rates	7
4 The RA0 Function.....	9
4.1 Asynchronous-to-Synchronous Conversion (RA0).....	9
4.2 Break signal	10
4.3 Overspeed/Underspeed	10
4.4 Parity Bits	10
4.5 Flow Control.....	10
5 The RA1 Function.....	11
5.1 Adaptation of synchronous data rates up to 38,4 kbit/s	11
5.1.1 Network Independent Clocking.....	12
5.1.1.1 Multiframe Structure	12
5.1.1.2 Encoding and compensation	12
6 The RA1'' function.....	13
6.1 Rate adaptation of 48 kbit/s user rates with DTE/DCE status to 64 kbit/s.....	13
6.2 Rate adaptation of 56 kbit/s user rate to 64 kbit/s.....	13
7 The RA2 Function.....	14
8 The RA1/RA1' Function	14
8.1 Single slot rates.....	14
8.1.1 Radio interface rate of 14,5 kbit/s	15
8.1.1.1 Multiframe structure over the radio-interface	15
8.1.1.2 Radio-interface data block for TCH/F14.4 channel coding	16
8.1.2 Radio Interface rate of 12 kbit/s.....	17
8.1.4 Radio Interface rate of 6 kbit/s	18
8.1.5 Radio Interface rate of 3,6 kbit/s (transparent services only)	19
8.1.6 Synchronisation.....	19
8.1.7 Idle frames.....	19
8.2 Multislot rates	19
8.2.1 TCH/F14.4 multislot operation	19
8.2.2 AIURs up to 38,4 kbit/s using TCH/F9.6 and TCH/F4.8 channel codings	20
8.2.3 AIURs up to 38,4 kbit/s using TCH/F14.4 channel coding.....	20
8.2.4 AIUR of 48 kbit/s; Intermediate rate of 64 kbit/s; Radio interface rate of 5× 12 kbit/s	21
8.2.5 AIUR of 48 kbit/s; Intermediate rate of 64 kbit/s; Radio interface rate of 4× 14,5 kbit/s	21
8.2.6 AIUR of 56 kbit/s; Intermediate rate of 64 kbit/s;.....	21
8.2.7 AIUR of 56 kbit/s; Intermediate rate of 64 kbit/s; Radio interface rate of 4 × 14,5 kbit/s	21
8.2.8 AIUR of 64 kbit/s; Radio interface rate of 6 × 12 kbit/s	22
8.2.9 AIUR of 64 kbit/s; Radio interface rate of 5 × 14,5 kbit/s	22
9 The RA1' Function	22
9.1 Synchronous user rates up to 9,6 kbit/s.....	22
9.2 Synchronous user rates from 9,6 kbit/s onward; TCH/F9.6/4.8 channel codings	23
9.3 Synchronous user rates from 9,6 kbit/s onward; TCH/F14.4 channel coding	23
10 The Split/Combine and Padding-functions	24
10.1 Data frame distribution into the substreams/channels by the Split/Combine function	24
10.1.1 Data frame distribution into the substreams/channels by the Split/Combine function (TCH/F9.6 and TCH/F4.8 channel codings)	24

10.1.2 Data block distribution into the substreams by the Split/Combine function (TCH/F14.4 channel coding) 24

10.2 Substream numbering in transparent operation 25

10.2.1 Substream numbering for TCH/F14.4 channel coding 25

10.3 Initial Substream Synchronisation for TCH/F9.6 and TCH/F4.8 channel codings 26

10.3.1 Initial Substream Synchronisation for TCH/F14.4 channel coding 26

10.4 Action on loss of synchronisation 26

10.4.1 Non-transparent services (TCH/F9.6 and TCH/F4.8 channel codings)..... 26

10.4.2 Transparent services (TCH/F9.6 and TCH/F4.8 channel codings) 26

10.4.3 Non-transparent services (TCH/F14.4 channel coding) 27

10.4.4 Transparent services (TCH/F14.4 channel coding)..... 27

10.5 Network independent clocking 27

10.5.1 Network Independent Clocking for TCH/F14.4 channel coding (both single- and multilinks)..... 27

10.5.1.1 Negative compensation..... 27

10.5.1.2 Positive compensation 28

10.6 Padding TCH/F frames when the AIUR is not a multiple of 9,6 or 4,8 kbit/s 28

10.6.1 Padding for TCH/F14.4 channel coding..... 28

11 Support of Non-Transparent Bearer Services29

11.1 Support of non-transparent operation for TCH/F9.6 and TCH/F4.8 channel codings 29

11.2 Support of non-transparent operation for TCH/F14.4 channel coding..... 30

12 Figures on Frame structures30

Annex A (informative): Stacks of rate adaptation35

A.1 Stacks of rate adaptation for 9,6/4,8 kbit/s single slot operation.....35

A.2 Stacks of rate adaptation for 14,4 kbit/s single slot operation36

A.3 Stacks of rate adaptation for 9,6/4,8 kbit/s multi slot operation38

A.4 Stacks of rate adaptation for 14,4 kbit/s multi slot operation40

Annex B (informative): An example of mapping Network Independent Clocking information for TCH/F14.4 when the S-interface is deployed42

Annex C (informative): Change Request History43

History44

Intellectual Property Rights

IPRs essential or potentially essential to the present document may have been declared to ETSI. The information pertaining to these essential IPRs, if any, is publicly available for **ETSI members and non-members**, and can be found in SR 000 314: *"Intellectual Property Rights (IPRs); Essential, or potentially Essential, IPRs notified to ETSI in respect of ETSI standards"*, which is available **free of charge** from the ETSI Secretariat. Latest updates are available on the ETSI Web server (<http://www.etsi.org/ipr>).

Pursuant to the ETSI IPR Policy, no investigation, including IPR searches, has been carried out by ETSI. No guarantee can be given as to the existence of other IPRs not referenced in SR 000 314 (or the updates on the ETSI Web server) which are, or may be, or may become, essential to the present document.

Foreword

This European Standard (Telecommunications series) has been produced by the Special Mobile Group (SMG).

The present document defines the rate adaptation functions to be used in Mobile Stations (MS) for adapting terminal interface data rates to the Mobile Station - Base Station System (MS - BSS) interface data rates within the digital cellular telecommunications system.

The contents of the present document is subject to continuing work within SMG and may change following formal SMG approval. Should SMG modify the contents of the present document it will be re-released with an identifying change of release date and an increase in version number as follows:

Version 6.x.y

where:

- 6 indicates Release 1997 of GSM Phase 2+
- x the second digit is incremented for all changes of substance, i.e. technical enhancements, corrections, updates, etc.
- y the third digit is incremented when editorial only changes have been incorporated in the specification.

Proposed national transposition dates	
Date of adoption of this EN:	3 September 1999
Date of latest announcement of this EN (doa):	31 December 1999
Date of latest publication of new National Standard or endorsement of this EN (dop/e):	30 June 2000
Date of withdrawal of any conflicting National Standard (dow):	30 June 2000

1 Scope

The present document defines the rate adaptation functions to be used in GSM PLMN Mobile Stations (MS)s for adapting terminal interface data rates to the Mobile Station - Base Station System (MS-BSS) interface data rates in accordance with GSM 03.10 [3].

The provision of these functions will depend on the services a particular station is designed to support.

NOTE: The present document should be considered together with GSM 08.20 [9] (Rate Adaptation on the BSS-MS Interface) to give a complete description of PLMN rate adaptation.

2 References

The following documents contain provisions which, through reference in this text, constitute provisions of the present document.

- References are either specific (identified by date of publication, edition number, version number, etc.) or non-specific.
- For a specific reference, subsequent revisions do not apply.
- For a non-specific reference, the latest version applies.
- A non-specific reference to an ETS shall also be taken to refer to later versions published as an EN with the same number.
- For this Release 1997 document, references to GSM documents are for Release 1997 versions (version 6.x.y).

- [1] GSM 01.04: "Digital cellular telecommunications system (Phase 2+); Abbreviations and acronyms".
- [2] GSM 02.34: "Digital cellular telecommunications system (Phase 2+); High Speed Circuit Switched Data (HSCSD) - Stage 1".
- [3] GSM 03.10: "Digital cellular telecommunications system (Phase 2+); GSM Public Land Mobile Network (PLMN) connection types".
- [4] GSM 03.34: "Digital cellular telecommunications system (Phase 2+); High Speed Circuit Switched Data (HSCSD) - Stage 2 Service Description".
- [5] GSM 05.03: "Digital cellular telecommunications system (Phase 2+); Channel coding".
- [6] GSM 07.01: "Digital cellular telecommunications system (Phase 2+); General on Terminal Adaptation Functions (TAF) for Mobile Stations (MS)".
- [7] GSM 07.02: "Digital cellular telecommunications system (Phase 2+); Terminal Adaptation Functions (TAF) for services using asynchronous bearer capabilities".
- [8] GSM 07.03: "Digital cellular telecommunications system (Phase 2+); Terminal Adaptation Functions (TAF) for services using synchronous bearer capabilities".
- [9] GSM 08.20: "Digital cellular telecommunications system (Phase 2+); Rate adaption on the Base Station System - Mobile-services Switching Centre (BSS - MSC) interface".
- [10] CCITT Recommendation V.110: "Support of data terminal equipments (DTEs) with V-Series interfaces by an integrated services digital network".
- [11] CCITT Recommendation X.30: "Support of X.21, X.21 bis and X.20 bis based terminal equipments (DTEs) by integrated services digital network (ISDN)".

2.1 Abbreviations and definitions

Abbreviations used in the present document are listed in GSM 01.04.

Overall data stream: The data stream in those parts of the network where the data flow is not split into multiple channels.

Substream: Stream of data with explicit or implicit numbering between splitter and combiner functions.

Channel: A physical full rate channel on the radio interface (TCH/F) independent of the contents

Multislot intermediate rate: Intermediate rate per substream in those parts of the network where the overall data stream is split into substreams.

Intermediate rate: Intermediate rate in the overall data stream.

Substream rate: The user rate including padding, if applicable, on one individual substream

3 General approach

GSM 03.10 defines the PLMN connection types necessary to support the GSM PLMN data and telematic services.

Within the MS there are several different data rate adaptation functions - and a Split/Combine-function in case of a multislot data configuration - which are combined as shown in GSM 03.10 as part of the connection type.

The rate adaptation functions are RA0, RA1, RA2, RA1', RA1'' and RA1/RA1'. The RA0, RA1 and RA2 are equivalent to those functions described in CCITT recommendation V.110 [11].

The RA1' function is similar to RA1 but has a reduced bit rate output compatible with the coding scheme proposed for data services on the radio interface.

The RA1'' function is used for converting between synchronous user rates of 48 and 56 kbit/s and the rate 64 kbit/s.

The RA1/RA1' is a relay function, used as indicated in GSM 03.10.

In multislot data-configurations the overall data stream is split into parallel substreams between the Split/Combine-functions.

3.1 Overview of the multislot data rates

For TCH/F9.6 and TCH/F4.8 channel codings, the multislot intermediate rates are 16 and 8 kbit/s per TCH/F, respectively.

For TCH/F14.4 channel coding, the multislot intermediate rate is 16 kbit/s per TCH/F.

Between the TE and the Split/Combine-function at the MS, where the overall data stream is not split, intermediate rates of 8, 16, 32 and 64 kbit/s are applicable

Table 1: AIUR/Multislot intermediate rates

Air interface user rate	DTE/DCE statuses	RA0	RA1/RA1'		RA1'	
			Multislot intermediate rate	Frame type	Radio interface rate	Padding
≤ 600 bit/s	X	X	8 kbit/s	80 bit frames	3,6 kbit/s	
1200 bit/s	X	X	8 kbit/s	80 bit frames	3,6 kbit/s	
2,4 kbit/s	X	X	8 kbit/s	80 bit frames	3,6 kbit/s	
4,8 kbit/s	X	X	8 kbit/s	80 bit frames	6 kbit/s	
9,6 kbit/s	X	X	16 kbit/s or 2×8 kbit/s	80 bit frames	12 kbit/s or 2×6 kbit/s	
14,4 kbit/s	X	X	2×16 kbit/s or 3×8 kbit/s	80 bit frames	2×12 kbit/s or 3×6 kbit/s	P (note 1)
			16 kbit/s Note 7		14,5 kbit/s	
19,2 kbit/s	X	X	2×16 kbit/s or 4×8 kbit/s	80 bit frames	2×12 kbit/s or 4×6 kbit/s	
28,8 kbit/s	X	X	3×16 kbit/s	80 bit frames	3×12 kbit/s	
			2 x 16 kbit/s Note 7		2×14,5 kbit/s	
38,4 kbit/s	X	X	4×16 kbit/s	80 bit frames	4×12 kbit/s	P (note 6)
			3 x 16 kbit/s Note7		3×14,5 kbit/s	
48 kbit/s	X		Note 2	Note 2	5×12 kbit/s	P (note 6)
			4 x 16 kbit/s Note7		4×14,5 kbit/s	
56 kbit/s			Note 2	Note 2	5×12 kbit/s (note 3)	P (note 6)
			4x16 kbit/s Note7		4×14,5 kbit/s	
64 kbit/s			Note 2	Note 2	6×12 kbit/s (note 3)	P (note 1)
					5×14,5 kbit/s	

P=Padding used

Table 2: AIUR / Intermediate rates

Air interface user rate	DTE/DCE statuses	RA0	RA1		RA1'	
			Intermediate rate	Frame type	Radio interface rate	Padding
≤ 600 bit/s	X	X	8 kbit/s	80 bit frames	3,6 kbit/s	
1200 bit/s	X	X	8 kbit/s	80 bit frames	3,6 kbit/s	
2,4 kbit/s	X	X	8 kbit/s	80 bit frames	3,6 kbit/s	
4,8 kbit/s	X	X	8 kbit/s	80 bit frames	6 kbit/s	
9,6 kbit/s	X	X	16 kbit/s	80 bit frames	12 kbit/s or 2×6 kbit/s	
14,4 kbit/s	X	X	32 kbit/s	80 bit frames	2×12 kbit/s or 3×6 kbit/s 1×14,5 kbit/s	P (note 1)
19,2 kbit/s	X	X	32 kbit/s	80 bit frames	2×12 kbit/s or 4×6 kbit/s	
28,8 kbit/s	X	X	64 kbit/s	80 bit frames	3×12 kbit/s 2×14,5 kbit/s	
38,4 kbit/s	X	X	64 kbit/s	80 bit frames	4×12 kbit/s 3×14,5 kbit/s	P (note 6)
48 kbit/s	X		Note 4	Note 4	5×12 kbit/s 4×14,5 kbit/s	P (note 6)
56 kbit/s			Note 4	Note 4	5×12 kbit/s (note 3) 4×14,5 kbit/s	P (note 6)
64 kbit/s			Note 5	Note 5	6×12 kbit/s (note 3) 5×14,5 kbit/s	P (note 1) (note 6)

P=Padding used

NOTE 1: For information on the padding procedure, please refer to clause 10 of the present document.

NOTE 2: No multislot intermediate rate; substreams combined at the BSS when TCH/F9.6/4.8 channel coding is used.

NOTE 3: AIUR 11,2 kbit/s per channel

NOTE 4: For this rate GSM-specific rate adaptation function RA1'' rather than RA1 is applied.

NOTE 5: For this rate RA1- and RA2- adaptations are not applied.

NOTE 6: Padding used as specified for TCH/F14.4 channel codings

NOTE 7: At the network side, RA1'/RA1 not applied; instead a TCH/F14,4-specific adaptation RA1'/RAA' used (GSM 08.20)

4 The RA0 Function

4.1 Asynchronous-to-Synchronous Conversion (RA0)

The RA0 Function is only used with asynchronous interfaces. Incoming asynchronous data is padded by the addition of stop elements to fit the nearest higher rate defined by 2 to the power n (where n ≤ 6) times 600 bit/s or, if applicable, to either 14,4 or 28,8 kbit/s. Thus both 75 bit/s and 300 bit/s user data signalling rates shall be adapted to a synchronous 600 bit/s stream. The resultant synchronous stream is fed to RA1 or RA1'.

Asynchronous user rate	Synchronous user rate
≤ 0.6 kbit/s	0.6 kbit/s
1,2 kbit/s	1,2 kbit/s
2,4 kbit/s	2,4 kbit/s
4,8 kbit/s	4,8 kbit/s
9,6 kbit/s	9,6 kbit/s
14,4 kbit/s	14,4 kbit/s
19,2 kbit/s	19,2 kbit/s
28,8 kbit/s	28,8 kbit/s
38,4 kbit/s	38,4 kbit/s

4.2 Break signal

The RA0 shall detect and transmit the break signal in the following fashion:

If the converter detects $2M$ to $2M+3$ bits, all of start polarity, where M is the number of bits per character in the selected format including start and stops bits, the converter shall transmit $2M+3$ bits of start polarity.

If the converter detects more than $2M+3$ bits all of start polarity, the converter shall transmit all these bits as start polarity.

The $2M+3$ or more bits of start polarity received from the transmitting sides shall be output to the receiving terminal.

The terminal must transmit on circuit 103 at least $2M$ bits stop polarity after the start polarity break signal before sending further data character. The converter shall then regain character synchronism from the following stop to start transition.

4.3 Overspeed/Underspeed

A RA0 shall insert additional stop elements when its associated terminal is transmitting with a lower than nominal character rate. If the terminal is transmitting characters with an overspeed of up to 1 %, the asynchronous-to-synchronous converter may delete stop elements as often as is necessary to a maximum of one for every eight characters at 1 % overspeed. The converter on the receiving side shall detect the deleted stop elements and reinsert them in the received data stream (circuit 104).

The realization of overspeed handling, as described above, at the interface to the associated terminal is implementation dependent. Possible implementations are e.g. the reduction of the length of the stop elements according to V.110 [9] or increased data rates between the TA and terminal.

4.4 Parity Bits

Possible parity bits included in the user data are considered as data bits by the RA0 function (and RA1 function).

4.5 Flow Control

Where applicable, this function is as specified in the relevant terminal adaptation function Specification (see GSM 07 series).

5 The RA1 Function

This function is used to adapt between the synchronous user rates, or the output of the RA0 function and the intermediate rate of 8, 16, 32 or 64 kbit/s.

5.1 Adaptation of synchronous data rates up to 38,4 kbit/s

Synchronous user rate	Intermediate rate
≤ 2,4 kbit/s	8 kbit/s
4,8 kbit/s	8 kbit/s
9,6 kbit/s	16 kbit/s
14,4 kbit/s	32 kbit/s
19,2 kbit/s	32 kbit/s
28,8 kbit/s	64 kbit/s
38,4 kbit/s	64 kbit/s

A CCITT V.110 80 bits frame is constructed using the user data bits received (from the RA0 in the asynchronous case), the values of the S bits are deduced from the R interface.

Adaptation of 600 bit/s to 8Kbit/s is performed by 8 times consecutive duplication of each user data bit. (Figure 9)

Adaptation of 1200 bit/s to 8 Kbit/s is performed by 4 times consecutive duplication of each user data bit. (Figure 8)

Adaptation of 2400 bit/s to 8kbit/s is performed by 2 times consecutive duplication of each user data bit. (Figure 7)

Adaptation of 4800 bit/s to 8 Kbit/s is performed by transmitting the bit stream with no duplication. (Figure 3)

Adaptation of 9600 bit/s to 16 Kbit/s is performed by transmitting the bit stream with no duplication (the emitting period is halved with respect to the 4800 bit/s case). (Figure 3)

Adaptation of 14400 bit/s to 32 Kbit/s is performed as for 3600 bit/s to 8 kbit/s (the emitting period is divided by four with respect to the 3600 bit/s case). (Adaptation of 3600 bit/s to 8 kbit/s is performed by transmitting the bit stream with no duplication.) (Figure 12)

Adaptation of 19200 bit/s to 32 Kbit/s is performed as for 4800 bit/s to 8 kbit/s (the emitting period is divided by four with respect to the 4800 bit/s case). (Figure 3)

Adaptation of 28800 bit/s to 64 Kbit/s is performed as for 3600 bit/s to 8 kbit/s (the emitting period is divided by eight with respect to the 3600 bit/s case). (Figure 12)

Adaptation of 38400 bit/s to 64 Kbit/s is performed as for 4800 bit/s 8 kbit/s (the emitting period is divided by eight with respect to the 4800 bit/s case). (Figure 3)

The CCITT V.110 80 bit frames shown in Figures 3 and 12 are used. The D bits are used to convey the user data and the S and X bits are used to convey channel control information according to the relevant terminal adapter function Specification.

The E bits are used to convey the following information:

- i) User Data Rate - E1, E2, E3 (for single slot operation see Figure 4, and for multislot operation Figure 4 and subclause 10.7)
- ii) Network Independent Clocking - E4, E5, E6
- iii) Multiframe Synchronisation - E7

The order of transmission of the 80 bit frame is from left to right and top to bottom.

5.1.1 Network Independent Clocking

Synchronous data signals received by the MT from the DTE at the MS or by IWF from the modem on the PSTN may not be synchronized to the PLMN. The following method shall be used to enable transfer of those data signals and the corresponding bit timing information via the V.110 frames. Such a situation would exist where the signals received from the modem at the IWF require its own clock or where the signals received from the DTE at the MS employs its own network independent clock. In any case, the frequency tolerance of the clocks involved is 100 ppm.

5.1.1.1 Multiframe Structure

The transmitting end of the GSM PLMN connection shall establish a multiframe structure utilizing bit E7 consisting of four frames by setting E7 in every fourth frame to binary 0. This structure is identical to the use of E7 in V.110 (and X.30) except that such a multiframe structure will exist for all user data rates. This frame synchronization will be achieved and maintained during the entire call so that corrections for the network independent clocking by the receiving end of the GSM PLMN connection can be easily recognized and applied based on the code words (in c1, c2, c3, c4 and c5) positioned in bits E4, E5 and E6 of two consecutive V.110 frames as illustrated in figure 1. Thus, the multiframe structure allows for one 5-bit code words to be transmitted every two V.110 frames for the purposes of network independent clocking. The two code-words may be different from each other within the multiframe shown in figure 1.

Frame	E4	E5	E6	E7
MF 0a	c1	c2	1	0
MF 1a	c3	c4	c5	1
MF 0b	c1	c2	1	1
MF 1b	c3	c4	c5	1

Figure 1: NIC Multiframe Structure

Once Multiframe synchronization is achieved, each code word is independently evaluated to determine the compensation needed, if any. The compensation is applied as explained in section 3.1.2 in V.110 frames MF 1a and MF 1b.

5.1.1.2 Encoding and compensation

The V.110 transmitter will use the following 5-bit code words, as shown in figure 2, to indicate the four possible states of compensation required for network independent clocking.

	c1	c2	c3	c4	c5
No compensation	1	1	1	1	1
Negative compensation	1	0	0	1	0
Positive compensation of a zero	0	1	0	0	1
Positive compensation of one	0	0	1	0	0

Figure 2: NIC Code Words

When negative compensation is indicated, one less user data bit than normal is transported in the affected frame (MF1a or MF1b). A negative compensation shall cause the receiver to delete the user data bit occupied by bit position D25, since the transmitter sets this to binary 1 and does not utilize this position for user data. At those user data rates where the user data bit is repeated, all copies of D25 shall be discarded. In case of 80-bit frames with 36 data bits, bit D19 is discarded instead.

When a positive compensation is indicated, one additional user data bit is transferred by means of the code word. At the receiver, a positive compensation will cause a user data bit of binary value 0 or 1, as indicated by the code word, to be inserted between the user data bits carried in bit positions D24 and D25 (in MF1a or MF1b) of the V.110 frame illustrated in figure 3. In case of 80-bit frames with 36 data bits, the insertion is done to between bits D18 and D19.

When no compensation is necessary, or when NIC is applied, the values of E4, E5, E6, E7, on the 4 multi frame scheme is:

Frame	E4	E5	E6	E7
MF 0a	1	1	1	0
MF 1a	1	1	1	1
MF 0b	1	1	1	1
MF 1b	1	1	1	1

When NIC is not applicable, the MS and the IWF shall disregard the received value of bits E4, E5, E6 and E7 in the data transmission phase.

NOTE: NIC is not applicable in the following cases:

- transparent asynchronous bearer services;
- the facsimile teleservices in the transparent mode;
- every transparent bearer services when interworking with an UDI Information Transfer Capability.

6 The RA1'' function

The RA1'' function is used for converting between synchronous user rates of 48 and 56 kbit/s and the 'intermediate' rate of 64 kbit/s. (RA1'' is a GSM-specific term which is used for the one-step adaptation of 48 and 56 kbit/s rates into 64 kbit/s as specified in ITU-T V.110. For the purposes of GSM specifications the term 'intermediate rate' is used for the resulting 64 kbit/s rate although this is not done in V.110 recommendation.)

6.1 Rate adaptation of 48 kbit/s user rates with DTE/DCE status to 64 kbit/s

A CCITT V.110 32 bits frame is constructed using the user data bits received, the values of the S bits are deduced from the R interface.

The CCITT V.110 32 bit frame shown in Figure 13 is used. The D bits are used for conveying the user data and the S and X bits are used for conveying channel control information according to the relevant terminal adapter function Specification. The order of transmission of the 32 bit frame is from left to right and top to bottom.

6.2 Rate adaptation of 56 kbit/s user rate to 64 kbit/s

A CCITT V.110 64 bits frame is constructed using the user data bits received.

The CCITT V.110 64 bit frame shown in figure 14 is used. The D bits are used for conveying the user data.

The order of transmission of the 64 bit frame is from left to right and top to bottom.

7 The RA2 Function

This procedure is based on the RA2 function as specified in CCITT V.110. It is used to rate adapt to/from the intermediate rates of 8, 16 or 32 kbit/s from/to the 64 kbit/s rate used at the S interface.

Intermediate rate	Rate at the S interface
8 kbit/s	64 kbit/s
16 kbit/s	64 kbit/s
32 kbit/s	64 kbit/s
64 kbit/s	64 kbit/s

For the intermediate- and user data rate of 64 kbit/s, the RA2 transmits the bit stream over the S-interface as it is.

It considers the 64 kbit/s stream over the S-interface to consist of octets, bits 1 through 8, with bit 1 being transmitted first.

The procedure requires that:

- i) The 8 kbit/s stream occupies bit position 1;
- ii) The 16 kbit/s bitstream occupies bit positions (1,2);
- iii) The 32 kbit/s bitstream occupies bit positions (1,2,3,4) ;
- iv) The order of transmission of the bits of the subrate stream is identical before and after rate adaptation.
- v) All unused bits in the 64 kbit/s stream are set to binary "1".

8 The RA1/RA1' Function

The RA1/RA1' function is used in transparent cases to convert between the intermediate rate and the input rate to the channel coder function for transmission over the radio interface. This conversion also appears on the infrastructure side in both transparent and non-transparent cases as specified in GSM 08.20 except for TCH/F14.4.

8.1 Single slot rates

Intermediate rate	Radio interface rate
8 kbit/s	3,6 kbit/s
8 kbit/s	6 kbit/s
16 kbit/s	12 kbit/s
32 kbit/s	14,5 kbit/s

There are four data rates (known as Radio Interface rates) used for data transfer to the channel coder. These are 14,5 kbit/s, 12 kbit/s, 6 kbit/s and 3.6 kbit/s, and in order to adapt the 8,16, and 32 kbit/s intermediate rates to these data rates, three processes are used.

Firstly the 17 synchronization bits are removed.

Secondly the E1, E2 and E3 bits are removed. For transparent services, the values of the E1, E2, E3 bits are determined at the MT and in case of TCH/F9.6 and TCH/F4.8, at the BTS based on the indication given by outband signalling (either in the User Rate field of the BC-IE of the SETUP message for the MT or in the Channel Type information in the ASSIGNMENT REQUEST message for the BSS). For non transparent services, the coding of the E1, E2 and E3 bits is described in GSM 08.20.

Thirdly, in the 3.6 kbit/s case, half the data bits are discarded. These processes result in modified CCITT V.110 frames of sizes 60,60 and 36 bits for the 12, 6 and 3.6 kbit/s data rates respectively. The resultant modified CCITT V.110 frames for the various user data rates are shown in figures 5 - 9.

Further procedures for TCH/F14.4 channel coder input rate in subclause 8.1.1.

8.1.1 Radio interface rate of 14,5 kbit/s

In this case one modified CCITT V.110 frame is received/sent from/to the network every 2.5 ms (see GSM 05.03). The RA1/RA1' function adds/subtracts the 17-bit synchronisation pattern, the F-, E-, X-, and S-bits to/from the 80-bit V.110-frames.

Bits M1 and M2 are transmitted along with the modified 36-bit V.110 frames every 20 ms over the radio interface (See GSM 05.03). Bit M2 is used by the RA1/RA1'-function for deriving/mapping the E-, S-, and X-bits. Bit M1 is used for multislot synchronisation. The usage of these bits is further elaborated in subclause 8.1.1.1.

The modified CCITT V.110 36-bit frame received/sent from/to the network at 14,4 kbit/s:

D1	D2	D3	D4	D5	D6
D7	D8	D9	D10	D11	D12
D13	D14	D15	D16	D17	D18
D19	D20	D21	D22	D23	D24
D25	D26	D27	D28	D29	D30
D31	D32	D33	D34	D35	D36

is converted/derived into/from the following 80-bit V.110-frame at 32 kbit/s. The E-, S-, and X-bits are mapped/extracted to/from the M2-bit sequence.

0	0	0	0	0	0	0	0	0
1	D1	D2	D3	D4	D5	D6	D7	S1
1	D7	D8	D9	D10	F	F	F	X
1	D11	D12	F	F	D13	D14	D15	S3
1	F	F	D15	D16	D17	D18	D19	S4
1	E1	E2	E3	E4	E5	E6	E7	E8
1	D19	D20	D21	D22	D23	D24	D25	S6
1	D25	D26	D27	D28	F	F	F	X
1	D29	D30	F	F	D31	D32	D33	S8
1	F	F	D33	D34	D35	D36	D37	S9

For the 36-bit frames the received D-bits are set as they were transmitted. For transparent services E, S, and X-bits are reproduced based on the M2-bit sequence as described in subclause 8.1.1.1. Bits E1, E2, and E3 are set according to the user data rate as shown in Figure 4 for transparent services.

8.1.1.1 Multiframe structure over the radio-interface

Bit M1 carries a 31-bit PN multiframe code 0000 1001 0110 0111 1100 0110 1110 101. One multiframe bit is transmitted every 20 ms, which means that one whole multiframe consists of 248 36-bit 2.5 ms frames.

Bit M2 carries V.24 circuit status information, network independent clocking (NIC) information and substream numbering as indicated in the following figure:

bit number	0 1 2 3	4 5 6 7	8 - 11	12- 15	16 - 19	20 - 23	24 - 27	28 - 30
M1:	0 0 0 0	1 0 0 1	0 1 1 0	0 1 1 1	1 1 0 0	0 1 1 0	1 1 1 0	1 0 1
M2:	### SB	SB X ##	# X SB SB	### SB	SB X ##	# X SB SB	NNNN	N SB SB

where ### = Substream number (multilink operation)

SB = the SB status bit

X = the X-status bit

NNNNN = Network independent clocking code

In the MS to Network direction the information carried by the M2-bit sequence is mapped in the following manner:

An M1/M2-bit pair is transmitted along each block of data containing eight modified V.110 36-bit frames. The three-bit #-sequence carries a number identifying each substream (multislot operation); the substreams are numbered 0,1,2 etc. The status- and NIC-information is mapped between the M2-sequence(s) and the V.110-frames. Bits SB and X are mapped to V.24 circuits as specified in subclause 8.2.2 of GSM 07.01

The SB-bit carries the V.110 SB-status information, and the X-bit the X-status information.

Five consecutive N-bits carrying an NIC-code in the M2-sequence indicate ‘negative compensation’ or ‘positive compensation’ if such a compensation is required. Otherwise ‘no compensation’ is indicated by the N-bits.

	N-bit 24 in M2-sequence	N-bit 25 in M2-sequence	N-bit 26 in M2-sequence	N-bit 27 in M2-sequence	N-bit 28 in M2-sequence
No compensation	1	1	1	1	1
Negative compensation	1	0	0	1	0
Positive compensation of a zero	0	1	0	0	1
Positive compensation of a one	0	0	1	0	0

The Network to MS direction:

The status-information is filtered as described in GSM 07.01. To change the SB- or X-status mode, it is required that at least two consecutive SB- or X-bits, respectively, carry the same value.

For NIC-procedure, refer to subclause 10.5.1.

8.1.1.2 Radio-interface data block for TCH/F14.4 channel coding

A radio-interface data block for a TCH/F14.4 channel consists of 8 36-bit data frames and bits M1 and M2 as shown in the following table:

																	M1	M2																		
1	D1	D2	D3	D4	D5	D6	D7	D8	D9	D10	D11	D12	D13	D14	D15	D16	D17	D18	D19	D20	D21	D22	D23	D24	D25	D26	D27	D28	D29	D30	D31	D32	D33	D34	D35	D36
2	D1	D2	D3	D4	D5	D6	D7	D8	D9	D10	D11	D12	D13	D14	D15	D16	D17	D18	D19	D20	D21	D22	D23	D24	D25	D26	D27	D28	D29	D30	D31	D32	D33	D34	D35	D36
3	D1	D2	D3	D4	D5	D6	D7	D8	D9	D10	D11	D12	D13	D14	D15	D16	D17	D18	D19	D20	D21	D22	D23	D24	D25	D26	D27	D28	D29	D30	D31	D32	D33	D34	D35	D36
4	D1	D2	D3	D4	D5	D6	D7	D8	D9	D10	D11	D12	D13	D14	D15	D16	D17	D18	D19	D20	D21	D22	D23	D24	D25	D26	D27	D28	D29	D30	D31	D32	D33	D34	D35	D36
5	D1	D2	D3	D4	D5	D6	D7	D8	D9	D10	D11	D12	D13	D14	D15	D16	D17	D18	D19	D20	D21	D22	D23	D24	D25	D26	D27	D28	D29	D30	D31	D32	D33	D34	D35	D36
6	D1	D2	D3	D4	D5	D6	D7	D8	D9	D10	D11	D12	D13	D14	D15	D16	D17	D18	D19	D20	D21	D22	D23	D24	D25	D26	D27	D28	D29	D30	D31	D32	D33	D34	D35	D36
7	D1	D2	D3	D4	D5	D6	D7	D8	D9	D10	D11	D12	D13	D14	D15	D16	D17	D18	D19	D20	D21	D22	D23	D24	D25	D26	D27	D28	D29	D30	D31	D32	D33	D34	D35	D36
8	D1	D2	D3	D4	D5	D6	D7	D8	D9	D10	D11	D12	D13	D14	D15	D16	D17	D18	D19	D20	D21	D22	D23	D24	D25	D26	D27	D28	D29	D30	D31	D32	D33	D34	D35	D36

The number on the left indicates the order of the data frames in the 290-bit block; the 36-bit frame in position one was received before that in position two etc. One such block is transmitted over the radio interface every 20 ms.

8.1.2 Radio Interface rate of 12 kbit/s

In this case one modified CCITT V.110 60 bit frame is received/sent from/to the network every 5ms (see GSM 05.03). The RA1/RA1' function will add/subtract the 17 bit synchronization pattern and the E1,E2 and E3 bits to/from each CCITT V.110 80 bit frame as follows:

The modified CCITT V.110 60 bits frame received/sent from/to the radio interface at 12 Kbit/s,

D1	D2	D3	D4	D5	D6	S1
D7	D8	D9	D10	D11	D12	X
D13	D14	D15	D16	D17	D18	S3
D19	D20	D21	D22	D23	D24	S4
E4	E5	E6	E7	D25	D26	D27
D28	D29	D30	S6	D31	D32	D33
D34	D35	D36	X	D37	D38	D39
D40	D41	D42	S8	D43	D44	D45
D46	D47	D48	S9			

is converted into the following a CCITT V.110 80 bits frame at 16 Kbit/s:

0	0	0	0	0	0	0	0
1	D1	D2	D3	D4	D5	D6	S1
1	D7	D8	D9	D10	D11	D12	X
1	D13	D14	D15	D16	D17	D18	S3
1	D19	D20	D21	D22	D23	D24	S4
1	E1	E2	E3	E4	E5	E6	E7
1	D25	D26	D27	D28	D29	D30	S6
1	D31	D32	D33	D34	D35	D36	X
1	D37	D38	D39	D40	D41	D42	S8
1	D43	D44	D45	D46	D47	D48	S9

In the case of the non transparent services, bits S1, X, S3, S4, E4, E5, E6, E7, S6, X (second occurrence), S8, and S9 carry bits D'1, D'2, D'3, D'4, D'5, D'6, D'7, D'8, D'9, D'10, D'11, and D'12, respectively.

For a modified CCITT V.110 60 bit frames received from the network, the received D, S and X bits or D and D' bits are set to the same value as the transmitted bits. Bits E1, E2, E3 are set according to the user data rate as shown in figure 4 for the transparent services, or the RLP multiframe and DTX indication as per GSM 08.20 in the non transparent case.

For modified CCITT V.110 60 bit frames transmitted over the network, the received D, S, and X bits or D and D' are set to the same value as the transmitted bits. Bits E1, E2, E3 are discarded.

8.1.4 Radio Interface rate of 6 kbit/s

In this case one modified CCITT V.110 60 bit frame is received/sent from/to the network every 10 ms (see GSM 05.03). The RA1/RA1' function will add/subtract the 17 bit synchronization pattern and the E1,E2 and E3 bits to/from each CCITT V.110 80 bit frame as follows:

The modified CCITT V.110 60 bits frame received/sent from/to the radio interface at 6 Kbit/s,

D1	D2	D3	D4	D5	D6	S1
D7	D8	D9	D10	D11	D12	X
D13	D14	D15	D16	D17	D18	S3
D19	D20	D21	D22	D23	D24	S4
E4	E5	E6	E7	D25	D26	D27
D28	D29	D30	S6	D31	D32	D33
D34	D35	D36	X	D37	D38	D39
D40	D41	D42	S8	D43	D44	D45
D46	D47	D48	S9			

is converted into the following a CCITT V.110 80 bits frame at 8 Kbit/s:

0	0	0	0	0	0	0	0
1	D1	D2	D3	D4	D5	D6	S1
1	D7	D8	D9	D10	D11	D12	X
1	D13	D14	D15	D16	D17	D18	S3
1	D19	D20	D21	D22	D23	D24	S4
1	E1	E2	E3	E4	E5	E6	E7
1	D25	D26	D27	D28	D29	D30	S6
1	D31	D32	D33	D34	D35	D36	X
1	D37	D38	D39	D40	D41	D42	S8
1	D43	D44	D45	D46	D47	D48	S9

In the case of the non transparent services, bits S1, X, S3, S4, E4, E5, E6, E7, S6, X (second occurrence), S8, and S9 carry bits D'1, D'2, D'3, D'4, D'5, D'6, D'7, D'8, D'9, D'10, D'11, and D'12, respectively.

For a modified CCITT V.110 60 bit frames received from the network, the received D, S and X bits or D and D' bits are set to the same value as the transmitted bits. Bits E1, E2, E3 are set according to the user data rate as shown in figure 4 for the transparent services, or the RLP multiframe and DTX indication as per GSM 08.20 in the non transparent case.

For modified CCITT V.110 60 bit frames transmitted over the network, the received D, S, and X bits or D and D' bits are set to the same value as the transmitted bits. Bits E1, E2, E3 are discarded.

It should be noted that this process is identical to that used for the 12 kbit/s case except that the frame repetition rates are halved.

8.1.5 Radio Interface rate of 3,6 kbit/s (transparent services only)

In this case one modified CCITT V.110 36 bit frame is received/sent from/to the network every 10ms (see GSM 05.03 [3]). The RA1/RA1' function will add/subtract the 17 bit synchronization pattern and the E1,E2 and E3 bits to/from each CCITT V.110 80 bit frame as follows:

The modified CCITT V.110 36 bits frame received/sent from/to the radio interface at 3.6 Kbit/s,

D1	D2	D3	S1	D4	D5	D6	X
D7	D8	D9	S3	D10	D11	D12	S4
E4	E5	E6	E7	D13	D14	D15	S6
D16	D17	D18	X	D19	D20	D21	S8
D22	D23	D24	S9				

is converted into the following a CCITT V.110 80 bits frame at 8 Kbit/s:

0	0	0	0	0	0	0	0
1	D1	D1	D2	D2	D3	D3	S1
1	D4	D4	D5	D5	D6	D6	X
1	D7	D7	D8	D8	D9	D9	S3
1	D10	D10	D11	D11	D12	D12	S4
1	E1	E2	E3	E4	E5	E6	E7
1	D13	D13	D14	D14	D15	D15	S6
1	D16	D16	D17	D17	D18	D18	X
1	D19	D19	D20	D20	D21	D21	S8
1	D22	D22	D23	D23	D24	D24	S9

For modified CCITT V.110 36 bit frames transmitted to the network, E1, E2, E3 are discarded. For modified CCITT V.110 36 bit frames received from the network, E1, E2, E3 are set as shown in figure 2.

NOTE: The action to be taken in the case where two bits which should have the same value (e.g. bits noted D1 are received with different values is for further study.

8.1.6 Synchronisation

Synchronization shall be in accordance with CCITT specification V.110, subclause 2.1.3.1 "Search of frame synchronization".

On loss of synchronization between the MS and the DTE, subclause 2.1.3.2 of V.110, "Frame synchronization monitoring and recovery", shall apply. In this case, idle frames with all data, status and E-bits set to binary "1" shall be sent to the radio interface. In the case of TCH/F14.4, the idle frames sent to the radio interface carry 289 bits set to '1' and the M1-bit carrying the PN-sequence.

As the synchronization process uses the V.110 frame alignment pattern only, the action is the same for Transparent and Non Transparent network support.

8.1.7 Idle frames

Whenever no data is received from the radio interface (e.g. frame stealing applies, layer 2 fill frames are received, etc.) idle frames shall be sent to the DTE. These are V.110 frames with frame alignment pattern according to CCITT recommendation. V.110 [11] and all data, status and E-bits set to binary "1".

8.2 Multislot rates

In multislot operation the transmission is performed using parallel substreams between the Split/Combine-functions.

8.2.1 TCH/F14.4 multislot operation

The information carried by the M2-sequences is read per substream; i.e. the substream number and a complete NIC-code are transferred through one substream.

A NIC-code is carried on as many substreams as is necessary to cover all NIC-compensations that have taken place. On channels where no NIC-compensation is carried, the N-bits are set to 'no compensation'. For the exact NIC-procedures, refer to subclause 10.5.1.

8.2.2 AIURs up to 38,4 kbit/s using TCH/F9.6 and TCH/F4.8 channel codings

Intermediate rate/AIUR	Radio interface rate
16 kbit/s / 9,6 kbit/s	2x6 kbit/s
32 kbit/s / 14,4; 19,2 kbit/s	2x12 or 3x6 or 4x6 kbit/s
64 kbit/s / 28,8; 38,4 kbit/s	3x12 or 4x12 kbit/s

In these cases, the data stream is mapped from 80-bit intermediate rate frames into modified frames of 60 bits for radio-interface transmission as specified in subclause 8.1 for 12 kbit/s and 6 kbit/s except for the following cases:

For AIURs 14,4 and 28,8 kbit/s using channel codings TCH/F4.8 and TCH/F9.6, respectively, four consecutive V.110 80-bit frames (Figure 12) are mapped onto three consecutive modified 60-bit V.110 (Figure 5 or 6) frames at the MS. The 4x36 data bits in the 80-bit frames are mapped onto the 3x48 data bits in the 60-bit frames. However, bits E4-E7 in the 80-bit frames are mapped onto the E4-E7 bits in the 60-bit frames when their value indicate either positive or negative compensation (NIC; See subclause 5.1.1). The E4-E7 bits that indicate ‘No compensation’ in the 80-bit frames need not be mapped onto the 60-bit frames. The S- and X-bits in every fourth 80-bit frame are not mapped onto the 60-bit frames. When radio interface rate of 2 x 12 kbit/s is used for carrying AIUR 14,4 kbit/s, padding is used in the 60-bit frames of the higher substream number (Subclause 10.6).

For substream numbering information, please refer to subclause 10 of the present document.

8.2.3 AIURs up to 38,4 kbit/s using TCH/F14.4 channel coding

Intermediate rate/AIUR	Radio interface rate
64 kbit/s / 28,8; 38,4 kbit/s	2x14,5 or 3x14,5

For AIURs 14,4 and 28,8 kbit/s the 36 data bits in the 80-bit V.110 intermediate rate frames are extracted and sent through the substreams in data blocks containing eight 36-bit frames as described in subclause 8.1. An M1/M2-bit pair is sent over the radio-interface along with each data block every 20 ms. These bits carry the multiframe, substream number, V.24 status, and NIC information as described in subclauses 8.1.1.1 and 8.2.1.

For AIUR 38.4 kbit/s the 80-bit V.110 intermediate rate frames carry 48 user data bits. The 290-bit blocks in the substreams of the lower substream numbers carry 288 user data bits while the 290-bit blocks in the substream of the highest substream number carries 192 user data bits; this means that five of the eight 36-bit frames making up the block carry 36 user data bits whereas the sixth frame carries 12 user data bits (5x36+12). Frames seven, eight, and the rest of the sixth frame are padded with ‘1’s.

The M2-bit sequences are used as described in subclauses 8.1.1.1 and 8.2.1

For NIC-procedures refer to subclauses 8.2.1 and 10.5.1. No NIC-values are transported in association with AIUR 38,4; the N-bits are set to ‘no compensation’.

8.2.4 AIUR of 48 kbit/s; Intermediate rate of 64 kbit/s; Radio interface rate of 5 × 12 kbit/s

One modified CCITT V.110 60 bit frame (Figure 5) is received/sent from/to a TCH/F every 5 ms (see GSM 05.03) resulting in an radio-interface rate of 12 kbit/s per channel.

One 60-bit radio-interface frame is converted into two CCITT V.110 32-bit frames at 64 kbit/s (Figure 13):

1	D1	D2	D3	D4	D5	D6	S1
0	D7	D8	D9	D10	D11	D12	X
1	D13	D14	D15	D16	D17	D18	S3
1	D19	D20	D21	D22	D23	D24	S4

8.2.5 AIUR of 48 kbit/s; Intermediate rate of 64 kbit/s; Radio interface rate of 4 × 14,5 kbit/s

For AIUR 48 kbit/s the 24 data bits in the 32-bit V.110-frames are extracted and sent through the substreams in 36-bit frames as described in subclause 8.1 . An M1/M2-bit pair is sent over the air-interface along each data block every 20 ms. This pair of bits carries the multiframe, substream, and V.24 status information as described in subclauses 8.1.1.1 and 8.2.1.

The 290-bit blocks in the highest numbered substream carry 96 user data bits (2×36+24).

The M2-bit sequences are used, for the applicable parts, as described in subclauses 8.1.1.1 and 8.2.1.

No NIC-values are transported in association with AIUR 48.0; the N-bits are set to ‘no compensation’.

8.2.6 AIUR of 56 kbit/s; Intermediate rate of 64 kbit/s;

Radio interface rate of 5 × 12 kbit/s

One modified CCITT V.110 60 bit frame (Figure 10) is received/sent from/to the network every 5 ms (see GSM 05.03) resulting in an radio-interface rate of 12 kbit/s per channel.

A modified CCITT V.110 60 bits radio-interface frame:

D1	D2	D3	D4	D5	D6	T1
D7	D8	D9	D10	D11	D12	T2
D13	D14	D15	D16	D17	D18	T3
D19	D20	D21	D22	D23	D24	T4
D25	D26	D27	D28	D29	D30	D31
D32	D33	D34	D35	D36	D37	D38
D39	D40	D41	D42	D43	D44	D45
D46	D47	D48	D49	D50	D51	D52
D53	D54	D55	D56			

NOTE: For information on the T-bits, please refer to subclause 10.2 of the present document.

is converted into a CCITT V.110 64 bits frame at 64 kbit/s:

D1	D2	D3	D4	D5	D6	D7	1
D8	D9	D10	D11	D12	D13	D14	1
D15	D16	D17	D18	D19	D20	D21	1
D22	D23	D24	D25	D26	D27	D28	1
D29	D30	D31	D32	D33	D34	D35	1
D36	D37	D38	D39	D40	D41	D42	1
D43	D44	D45	D46	D47	D48	D49	1
D50	D51	D52	D53	D54	D55	D56	1

8.2.7 AIUR of 56 kbit/s; Intermediate rate of 64 kbit/s; Radio interface rate of 4 × 14,5 kbit/s

For AIUR 56 kbit/s the 56 data bits in the 64-bit V.110 frames are extracted and sent through the substreams in 36-bit frames as described in subclause 8.1. An M1/M2-bit pair is sent over the air-interface along each data block every 20 ms. This pair of bits carries the multiframe and substream numbering information as described in subclause 8.1.1.1.

The 290-bit blocks in the highest numbered substream carry 256 user data bits (7×36+4).

The M2-bit sequences are used, for the applicable parts, as described in subclauses 8.1.1.1 and 8.2.1.

No V.24 status or NIC-values are transported in association with AIUR 56.0; the N-bits are set to ‘no compensation’.

8.2.8 AIUR of 64 kbit/s; Radio interface rate of 6 × 12 kbit/s

One modified CCITT V.110 60 bit frame (Figure 10) is received/sent from/to the network every 5 ms (see GSM 05.03) resulting in an radio-interface rate of 12 kbit/s per channel.

A modified CCITT V.110 60 bits radio-interface frame:

D1	D2	D3	D4	D5	D6	T1
D7	D8	D9	D10	D11	D12	T2
D13	D14	D15	D16	D17	D18	T3
D19	D20	D21	D22	D23	D24	T4
D25	D26	D27	D28	D29	D30	D31
D32	D33	D34	D35	D36	D37	D38
D39	D40	D41	D42	D43	D44	D45
D46	D47	D48	D49	D50	D51	D52
D53	D54	D55	D56			

NOTE: For information on the T-bits, please refer to subclause 10.2 of the present document.

The data bits are extracted from the 60-bit frames received from the network; six frames, one of which carries padding as explained in subclause 10.6, carry 320 bits of user data per 5 ms resulting in a 64 kbit/s user rate which is sent forward as such.

8.2.9 AIUR of 64 kbit/s; Radio interface rate of 5 × 14,5 kbit/s

For AIUR 64 kbit/s the 64 data bits in the 64-bit V.110 frames are extracted and sent through the substreams in 36-bit frames as described in subclause 8.1. An M1/M2-bit pair is sent over the air-interface along each data block every 20 ms. This pair of bits carries the multiframe and substream numbering information as described in subclause 8.1.1.1.

The 290-bit blocks in the highest numbered substream carry 128 user data bits (3×36+20).

The M2-bit sequences are used, for the applicable parts, as described in subclauses 8.1.1.1 and 8.2.1.

No V.24 status or NIC-values are transported in association with AIUR 64.0; the N-bits are set to ‘no compensation’.

9 The RA1' Function

This function is used to adapt between the synchronous user data rates, or the output of the RA0 function and the radio interface data rates of 3,6, 6, 12 or 14,5 kbit/s.

9.1 Synchronous user rates up to 9,6 kbit/s

Synchronous user rate	Rate at the radio interface
≤ 2,4 kbit/s	3.6 kbit/s
4,8 kbit/s	6 kbit/s
9,6 kbit/s	12 kbit/s or 2x6 kbit/s

The modified CCITT V.110 36 or 60 bit frame structures for each user rate are shown in figures 5 - 9. The meaning of the bits is described in clause 5.

9.2 Synchronous user rates from 9,6 kbit/s onward; TCH/F9.6/4.8 channel codings

Synchronous user rate	Total rate at the radio interface	DTE/DCE statuses	60 Bit frame structure	Single slot rate at the radio interface
14,4 kbit/s	24 kbit/s or 18 kbit/s	X	9,6 kbit/s or 4,8 kbit/s (Figs. 5 and 15) Note	12 kbit/s or 6 kbit/s
19,2 kbit/s	24 kbit/s	X	9,6 kbit/s or 4,8 kbit/s (Fig. 5)	12 kbit/s or 6 kbit/s
28,8 kbit/s	36 kbit/s	X	9,6 kbit/s (Fig. 5)	12 kbit/s
38,4 kbit/s	48 kbit/s	X	9,6 kbit/s (Fig. 5)	12 kbit/s
48 kbit/s	60 kbit/s	X	9,6 kbit/s (Fig. 5)	12 kbit/s
56 kbit/s	60 kbit/s		11,2 kbit/s (Fig.10)	12 kbit/s
64 kbit/s	72 kbit/s		11,2 kbit/s (Figs. 10 and 16) Note	12 kbit/s

NOTE: Padding is used in frames making up the data substream of the highest substream number.

Modified CCITT V.110 60 bit frames structures are those shown in figures 5, (6,) and 10. The structure to apply is that for the partial user rate. The meaning of the bits is described in clauses 5 and 7. For description of the padding procedure, please refer to clause 10 of the present document.

9.3 Synchronous user rates from 9,6 kbit/s onward; TCH/F14.4 channel coding

Synchronous user rate	Total rate at the radio interface	DTE/DCE statuses	Air-interface bit frame structure	Single slot rate at the radio interface
14,4 kbit/s	14,5 kbit/s	X	36 bits, 290-bit block	14,5 kbit/s
28,8 kbit/s	29.0 kbit/s	X	36 bits, 290-bit block	14,5 kbit/s
38,4 kbit/s	43.5 kbit/s	X	36 bits, 290-bit block	14,5 kbit/s (note)
48 kbit/s	58.0 kbit/s	X	36 bits, 290-bit block	14,5 kbit/s (note)
56 kbit/s	58.0 kbit/s		36 bits, 290-bit block	14,5 kbit/s (note)
64 kbit/s	72.5 kbit/s		36 bits, 290-bit block	14,5 kbit/s (note)

NOTE: Padding used as specified for TCH/F14.4 channel coding

The format used for transferring a synchronous data stream over the radio-interface is a multiframe consisting of 31 data blocks. Each data block contains bits M1 and M2 followed by 288 user data bits sent/received over the radio-interface every 20 ms. The M1-bit carries a 31-bit PN-sequence used for aligning the multiframe(s), whereas the M2-bit carries substream numbering, status information, and NIC-codes as described in subclauses 8.1.1.1 and 8.2.1. The status information carried by the M2-sequence(s) is interpreted as specified in subclause 8.2.2 of GSM 07.01. When three consecutive M2-bits carry a substream number, this is interpreted as specified in clause 10. Five consecutive M2-bits carrying NIC-information are interpreted according to subclause 8.1.1.1. For the exact NIC-procedures refer to subclause 10.5.1.

10 The Split/Combine and Padding-functions

10.1 Data frame distribution into the substreams/channels by the Split/Combine function

10.1.1 Data frame distribution into the substreams/channels by the Split/Combine function (TCH/F9.6 and TCH/F4.8 channel codings)

a) In the transparent case the Split/Combine-function distributes the V.110-frames into the substreams and recombines the overall data stream from the substreams according to the following rules:

In the overall data stream

- 1) the frame in position p in substream q precedes the frame in position p in substream $q+1, 0 \leq q < n-1$
- 2) the frame in position p in substream $n-1$ precedes the frame in position $p+1$ in substream 0 ;

where in the rules above n is the number of substreams.

b) In the non-transparent case the Split/Combine-function distributes the RLP-frames — or the four V.110-frames making up an RLP-frame (Reference: GSM 08.20, Clause 10) — into channels so that one whole RLP-frame is carried through one channel. Furthermore the RLP-frames are distributed into the available channels cyclically; i.e. the frames are sent in the available time slots in a recurring sequence in which only every n th RLP-frame is sent through the same channel (n is the number of the available time slots). The receiving Split/Combine-function recombines the overall data stream according to the inherent RLP-frame numbering, i.e. the $N(S)$ -numbers in the RLP-frame header (GSM 04.22).

10.1.2 Data block distribution into the substreams by the Split/Combine function (TCH/F14.4 channel coding)

a) Transparent services

The Split/Combine-function distributes the user data carried in the 290-bit blocks (Refer to subclause 8.1.1.2) into the substreams and recombines the overall data stream from the substreams according to the following rules:

In the overall data stream:

- 1) the data block in position m of multiframe in substream q precedes the data block in position m of multiframe in substream $q+1, 0 \leq q < n-1, 0 \leq m \leq 30$.
- 2) the data block in position m of multiframe in substream $n-1$ precedes the data block in position $m+1$ of multiframe in substream 0 ;

where in the rules above n is the number of substreams.

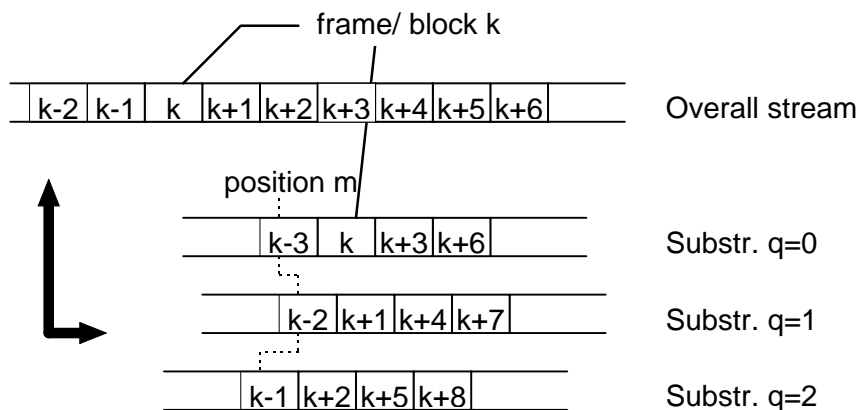

Figure 2a: Distribution of data frames or data blocks into the substreams in transparent operation

b) Non-transparent services

In the non-transparent operation the Split/Combine-function distributes the RLP-frames into substreams so that one whole RLP-frame is carried through one substream. This means that the two 290-bit air-interface blocks carrying one RLP-frame are transmitted through the same substream. Furthermore the RLP-frames are distributed into the available substreams so that the resulting delay in the overall data stream is kept as small as possible. The receiving Split/Combine-function recombines the overall data stream according to the inherent RLP-frame numbering, i.e. the N(S)-numbers in the RLP-frame header (GSM 04.22).

10.2 Substream numbering in transparent operation

In transparent multislot data configurations of more than one TCH/F the parallel data substreams between the Split/Combine-functions carry inband substream numbering. The status bits S1, S3, and the X-bit between data bits D12 and D13 (Figures 5 and 6) are used for transferring this substream numbering information (S1 is the MSB and S3 the LSB). The substreams are numbered 0, 1, 2, 3 etc. regardless of the physical channels through which the substreams are transmitted. The highest substream number is one less than the number of physical channels in use at a given time; i.e. the numbering cycle changes when physical channels are either added to or removed from a connection.

The S4-bit is used for frame synchronisation between the parallel substreams. This bit follows a 31-bit PN-sequence of 0000 1001 0110 0111 1100 0110 1110 101. This thirty one bit sequence is used for substream resynchronisation in cases where delay has occurred on one or more substream(s); the position of a frame in a substream can be determined modulo 31 by the values of the S4-bit in a sequence of 5 consecutive frames including the frame in question. Provided that the relative delay between substreams is less than 75 ms (i.e. less than a 15-frame displacement), this and the frame distribution rules given in subclause 10.1 are sufficient to determine the correct order of the frames.

Bits S6, S8, S9, and the other X-bit are used for conveying channel control information according to the relevant terminal adapter function specification.

These rules apply to all multislot data AIURs up to and including 48 kbit/s. When the received 48 kbit/s AIUR is converted into 64 kbit/s rate, the bits extracted from the 60-bit radio interface frames (Figure 5) are mapped into the 32-bit frame format of Figure 13. Here the values for the status bits S1, X, S3, and S4 in the 32-bit frame must be derived from status bits S6, X, S8, and S9 in the radio-interface frame because status bits S1, X, S3, and S4 in the upper right hand corner of the 60-bit frame have been used for data substream numbering as described above.

In the 11,2 kbit/s frames used for AIURs 56 and 64 kbit/s (Figure 10) the T1, T2, T3 (T1 the MSB and T3 the LSB) are used for carrying the substream numbering as status bits S1, X, and S3 do according to the definition given in the first paragraph of subclause 10.1. Bit T4 is used for carrying the substream synchronisation sequence just as status bit S4 does in the description given in the second paragraph of subclause 10.2.

10.2.1 Substream numbering for TCH/F14.4 channel coding

Bit M1 carries the multiframe sequence 0000 1001 0110 0111 1100 0110 1110 101. The number of the substream in which a multiframe is sent is carried four times in a 31-bit period of the M2-sequence. In the three-bit number code the bit in the lowest bit position is the MSB (See table in subclause 8.1.1.1).

10.3 Initial Substream Synchronisation for TCH/F9.6 and TCH/F4.8 channel codings

The Split and combine-function is responsible for controlling the initial synchronisation procedure as described in GSM 07.01.

10.3.1 Initial Substream Synchronisation for TCH/F14.4 channel coding

The Split and combine-function is responsible for controlling the initial synchronisation procedure as described in GSM 07.01.

10.4 Action on loss of synchronisation

Two interfaces are involved in the TAF regarding the need for the data frame synchronisation, i.e the TAF/multichannel interface and the TAF/TE interface.

10.4.1 Non-transparent services (TCH/F9.6 and TCH/F4.8 channel codings)

If the TAF detects a loss of frame synchronisation on the TAF/TE interface, the TAF initiates re-synchronisation on that link, in line with the procedures specified in CCITT V.110. No related action shall be taken by the TAF on the TAF/multichannel link(s) or on the V.110 frames being transmitted towards the TE.

If the TAF detects a loss of synchronisation on the TAF/multichannel link(s) - on one or more channels - then the TAF initiates re-synchronisation process on the channel(s) which are out of synchronisation. In this case the TAF searches for the data frame structure in those channels in which the synchronisation has been lost. No related action shall be taken regarding the frames generated towards the TE by the TAF during the re-synchronisation process.

No action shall be taken on the frames being transmitted towards the MSC, other than to continue sending them normally.

10.4.2 Transparent services (TCH/F9.6 and TCH/F4.8 channel codings)

If the TAF detects a loss of frame synchronisation on the TAF/TE interface, the TAF initiates a re-synchronisation on that link, in line with the procedures specified in CCITT V.110. No further action shall be taken by the TAF on the TAF/multichannel link or on the V.110 frames being transmitted towards the TE.

If the TAF detects a loss of synchronisation on the TAF/multichannel link - on one or more channels - the TAF initiates re-synchronisation process on the channel(s) which are out of synchronisation. In this case the TAF searches for the data frame structure in those channels in which the synchronisation has been lost. The information received from the channels shall continue to be processed as if the synchronisation had not been lost; corrupted data is forwarded towards the TE during the re-synchronisation process.

No action shall be taken on the frames being transmitted towards the MSC, other than to continue sending them normally.

10.4.3 Non-transparent services (TCH/F14.4 channel coding)

If the TAF detects a loss of frame synchronisation on the TAF/TE interface, the TAF initiates re-synchronisation on that link, in line with the procedures specified in CCITT V.110. No related action shall be taken by the TAF on the TAF/multichannel link(s) or on the frames being transmitted towards the TE.

If the TAF detects a loss of synchronisation on the TAF/multichannel link(s) - on one or more channels - then the TAF initiates re-synchronisation process on the channel(s) which are out of synchronisation. In this case the TAF searches for the multiframe structure in those channels in which the synchronisation has been lost. No related action shall be taken regarding the frames generated towards the TE by the TAF during the re-synchronisation process.

No action shall be taken on the frames being transmitted towards the MSC, other than to continue sending them normally.

10.4.4 Transparent services (TCH/F14.4 channel coding)

If the TAF detects a loss of frame synchronisation on the TAF/TE interface, the TAF initiates a re-synchronisation on that link, in line with the procedures specified in CCITT V.110. No further action shall be taken by the TAF on the TAF/multichannel link or on the frames being transmitted towards the TE.

If the TAF detects a loss of synchronisation on the TAF/multichannel link - on one or more channels - the TAF initiates re-synchronisation process on the channel(s) which are out of synchronisation. In this case the TAF searches for the multiframe structure in those channels in which the synchronisation has been lost. The information received from the channels shall continue to be processed as if the synchronisation had not been lost; corrupted data is forwarded towards the TE during the re-synchronisation process.

No action shall be taken on the frames being transmitted towards the MSC, other than to continue sending them normally.

10.5 Network independent clocking

The data frames carrying an NIC-multiframe (subclause 5.1.1) indicating a positive or negative compensation are distributed into the substreams according to subclause 10.1.

10.5.1 Network Independent Clocking for TCH/F14.4 channel coding (both single- and multilinks)

In the following, 'a data bit position' means a non-padded bit position in the 290-bit radio interface blocks.

The NIC-codes are read per substream, i.e. the sequence of five N-bits in a substream carries one complete NIC-code.

If NIC-compensation(s) take(s) place in the overall user data flow :

10.5.1.1 Negative compensation

a) From overall data stream to substreams

When only one substream is used and the data is mapped to the radio interface blocks, the 'extra null bit', which is set to '1', (subclause 5.1.1) is mapped to the first data bit position of the radio interface block which carries the fifth N-bit in the 31-block multiframe structure. The five N-bits encode 'negative compensation' as described in clause 5.

If more than one substream is used, and more than one negative compensation should be performed the 'extra null bit' is mapped to the first data bit position of the radio interface block which carries the fifth N-bit in the 31-block multiframe structure in as many substreams as necessary to perform all compensations. In those substreams where no compensation is needed the N-bits are set to 'no compensation'.

b) From substreams to overall data stream

When a radio interface block carrying the fifth bit of an NIC-code indicating negative compensation is received, the receiver discards the first data bit of the block.

10.5.1.2 Positive compensation

a) From overall data stream to substreams

An NIC-code indicating positive compensation means that the data bit from the overall data stream preceding the bit mapped into the first position of the data block conveying the second N-bit is carried encoded by the five N-bits.

If more than one substream is used, and if more than one compensation has taken place in the overall data stream, more than one substream carries a NIC-code indicating 'positive compensation'. In those substreams where no NIC-compensation is needed the N-bits indicate 'no compensation'.

b) From substreams to overall data stream

When an NIC-code indicating positive compensation is received, an extra '0' or '1' — depending on whether a compensation of a '0' or '1' is indicated — is mapped to before the first data bit position of the block with which the second bit of the NIC-code is associated.

10.6 Padding TCH/F frames when the AIUR is not a multiple of 9,6 or 4,8 kbit/s

When the required AIUR is not a multiple of the rates supported by TCH/F4.8 or TCH/F9.6, padding is used for producing the required AIUR.

To achieve the required AIUR the data bits are distributed across the substreams 1 to n as follows:

- Substream(s) 1 (to n-1) carry multiples of the rate supported by the channel coding used.
- Substream n carries the remaining amount of data bits required to achieve the required AIUR. The remainder of data stream n carries padding bits set to binary value '1'.

Padding for AIUR 14,4 kbit/s:

The frame of the lower substream number carries full 9,6 kbit/s. The frame of the higher substream number carries 4,8 kbit/s of user data in bit positions D1-D24 while bit positions D25-D48 are inserted with binary "1"s. (Figure 15)

Padding for AIUR 64 kbit/s:

The frames numbered 1-5 carry full 11,2 kbit/s. Frame number 6 carries 8.0 kbit/s of user data in bit positions D1-D40 while bit positions D41-D56 are inserted with binary "1"s. (Figure 16)

10.6.1 Padding for TCH/F14.4 channel coding

Padding for TCH/F14.4 channel coding is presented in the corresponding parts of clause 8.

10.7 Handling of the E1-E3 bits in multislot operation

Between the Split / Combine functions the substreams carry the code associated with the substream rate as defined in Figure 4. When the substreams are combined the code is set to correspond to the overall AIUR according to Figure 4.

11 Support of Non-Transparent Bearer Services

In the case of non-transparent services, the RA1' function provides access to the 12 and 6 kbit/s radio interface data rates. (Alignment of RLP frames with the four TDMA slots makes it physically impossible to provide 3,6 kbit/s.) The RA1' function is not applied in case of TCH/F14.4 channel coding (Radio interface rate $n \times 14.5$ kbit/s, $1 \leq n \leq 4$).

Air interface user rate	Radio interface rate
4,8 kbit/s	6 kbit/s
9,6 kbit/s	12 kbit/s or 2×6 kbit/s
14,4 kbit/s	14,5 kbit/s or 2×12 kbit/s or 3×6 kbit/s
19,2 kbit/s	2×12 kbit/s or 4×6 kbit/s
28,8 kbit/s	2×14,5 kbit/s or 3×12 kbit/s
38,4 kbit/s	3×14,5 kbit/s or 4×12 kbit/s
43.2 kbit/s	3×14,5 kbit/s
57.6 kbit/s	4×14,5 kbit/s

11.1 Support of non-transparent operation for TCH/F9.6 and TCH/F4.8 channel codings

This access results in the use of a modified CCITT V.110 60 bit frame for non-transparent services (figure 11). In this case, the RA1' function also provides for alignment of four modified CCITT V.110 60 bit frames sent on the same radio slot corresponding with each complete 240 bit frame to be encoded by the radio subsystem as a single unit (see GSM 05.03). The difference between the non-transparent 60 bit frame and the 60 bit frame for the transparent service is that the bit positions used for status in a transparent frame are used to carry data (designated as D' bits in figure 11).

NOTE: The status bits SA, SB, and the X bit are embedded in the L2R-PDU frames (see GSM 07.01, 07.02, and 07.03).

The first bit of each RLP frame to be transmitted will correspond to the first bit (D1) of the first 60 bit frame in a four frame sequence and the last bit will correspond to the last bit (D'12) of the last 60 bit frame in a four frame sequence. Each 60 bit frame is filled from left to right starting at D1 (see figure 11).

The radio subsystem provides for the synchronous transmission and reception of 240 bit RLP frames through a connection consisting of up to four TCH/Fs. An RLP-frame is received/sent from/to a particular radio channel every 20 ms (12 kbit/s radio interface rate) or every 40 ms (6 kbit/s radio interface rate) irrespective of the user rate.

The request to use 6 kbit/s radio interface rate on a Full Rate Channel is indicated in the BC-IE by setting the NIRR bit to 6 kbit/s (Negotiation procedure see GSM 07.01) and selecting a Full Rate Channel and Non-Transparent service. If the entity receiving the BC-IE is unable to support this request then the 12 kbit/s radio interface rate shall be provided automatically.

Occasions may arise when there is no RLP frame ready to be transmitted. In this case a frame of 240 zeroes will be transmitted. This frame will be discarded by the distant RLP function, due to FCS failure, but will allow physical link synchronization to be maintained between the MS and the MSC.

In the case of an asymmetric connection the BTS shall send V110 idle frames towards the MSC on the channels which are unused in the direction from the MS towards the MSC. This will ensure that the IWF does not interpret V110 frames which are not originated from the MS as complete RLP frames.

11.2 Support of non-transparent operation for TCH/F14.4 channel coding

In 14,4 kbit/s channel 576-bit RLP-frames are used.

The RA1' function is not applied in this case. Instead the RLP-, or in multislot operation the Split/Combine- function, handles the 290-bit data blocks received/sent from/to the network. The M1- bit is used for indicating the RLP-frame halves: in the first half M1= 0 and in the second half M1=1. Bit M2 is used for DTX-indication between the BSS and MSC as described in GSM 08.20

In cases where no RLP-frame is ready to be transmitted, a sequence of 576 '1's is transmitted. This frame will be discarded by the distant RLP-function due to FCS failure.

In the case of an asymmetric connection the BTS shall send idle frames towards the IWF on the channels which are unused in the direction from the MS towards the MSC, as specified in GSM 08.60. This will ensure that the IWF does not interpret sequences of frames which are not originated from the MS as complete RLP frames.

12 Figures on Frame structures

Octet No.	Bit number							
	1	2	3	4	5	6	7	8
0	0	0	0	0	0	0	0	0
1	1	D1	D2	D3	D4	D5	D6	S1
2	1	D7	D8	D9	D10	D11	D12	X
3	1	D13	D14	D15	D16	D17	D18	S3
4	1	D19	D20	D21	D22	D23	D24	S4
5	1	E1	E2	E3	E4	E5	E6	E7
6	1	D25	D26	D27	D28	D29	D30	S6
7	1	D31	D32	D33	D34	D35	D36	X
8	1	D37	D38	D39	D40	D41	D42	S8
9	1	D43	D44	D45	D46	D47	D48	S9

Figure 3: The CCITT V.110 80 bit RA1 frame structure

Intermediate Data Rate				E1	E2	E3	Note
8 kbit/s	16 kbit/s	32 kb/s	64 kb/s				
600				1	0	0	Note
1200				0	1	0	
2400				1	1	0	
4800	9600	19200	38400	0	1	1	
		14400	28800	1	0	1	

NOTE: The 300 bit/s user data rate is carried on the 600 bit/s synchronous stream by adding stop elements, see subclause 4.1.

Figure 4: Coding of data rates

D1	D2	D3	D4	D5	D6	S1
D7	D8	D9	D10	D11	D12	X
D13	D14	D15	D16	D17	D18	S3
D19	D20	D21	D22	D23	D24	S4
E4	E5	E6	E7	D25	D26	D27
D28	D29	D30	S6	D31	D32	D33
D34	D35	D36	X	D37	D38	D39
D40	D41	D42	S8	D43	D44	D45
D46	D47	D48	S9			

Figure 5: Modified CCITT V.110 60 bit frame for 9,6 kbit/s transparent data

D1	D2	D3	D4	D5	D6	S1
D7	D8	D9	D10	D11	D12	X
D13	D14	D15	D16	D17	D18	S3
D19	D20	D21	D22	D23	D24	S4
E4	E5	E6	E7	D25	D26	D27
D28	D29	D30	S6	D31	D32	D33
D34	D35	D36	X	D37	D38	D39
D40	D41	D42	S8	D43	D44	D45
D46	D47	D48	S9			

Figure 6: Modified CCITT V.110 60 bit frame for 4,8. kbit/s transparent data

a)

D1	D2	D3	S1	D4	D5	D6	X
D7	D8	D9	S3	D10	D11	D12	S4
E4	E5	E6	E7	D13	D14	D15	S6
D16	D17	D18	X	D19	D20	D21	S8
D22	D23	D24	S9				

b)

0	0	0	0	0	0	0	0
1	D1	D1	D2	D2	D3	D3	S1
1	D4	D4	D5	D5	D6	D6	X
1	D7	D7	D8	D8	D9	D9	S3
1	D10	D10	D11	D11	D12	D12	S4
1	1	1	0	E4	E5	E6	E7
1	D13	D13	D14	D14	D15	D15	S6
1	D16	D16	D17	D17	D18	D18	X
1	D19	D19	D20	D20	D21	D21	S8
1	D22	D22	D23	D23	D24	D24	S9

Figure 7: a) Modified CCITT V.110 36 bit frame for 2,4 kbit/s transparent data and b) the corresponding intermediate rate frame at 8 kbit/s

a)

D1	D1	D2	S1	D2	D3	D3	X
D4	D4	D5	S3	D5	D6	D6	S4
E4	E5	E6	E7	D7	D7	D8	S6
D8	D9	D9	X	D10	D10	D11	S8
D11	D12	D12	S9				

b)

0	0	0	0	0	0	0	0
1	D1	D1	D1	D1	D2	D2	S1
1	D2	D2	D3	D3	D3	D3	X
1	D4	D4	D4	D4	D5	D5	S3
1	D5	D5	D6	D6	D6	D6	S4
1	0	1	0	E4	E5	E6	E7
1	D7	D7	D7	D7	D8	D8	S6
1	D8	D8	D9	D9	D9	D9	X
1	D10	D10	D10	D10	D11	D11	S8
1	D11	D11	D12	D12	D12	D12	S9

Figure 8: a) Modified CCITT V.110 36 bit frame for 1,2 kbit/s transparent data and b) the corresponding intermediate rate frame at 8 kbit/s

a)

D1	D1	D1	S1	D1	D2	D2	X
D2	D2	D3	S3	D3	D3	D3	S4
E4	E5	E6	E7	D4	D4	D4	S6
D4	D5	D5	X	D5	D5	D6	S8
D6	D6	D6	S9				

NOTE: The 300 bit/s user data rate is carried on the 600 bit/s synchronous stream by adding stop elements, see subclause 4.1.

b)

0	0	0	0	0	0	0	0
1	D1	D1	D1	D1	D1	D1	S1
1	D1	D1	D2	D2	D2	D2	X
1	D2	D2	D2	D2	D3	D3	S3
1	D3	D3	D3	D3	D3	D3	S4
1	1	0	0	E4	E5	E6	E7 (note)
1	D4	D4	D4	D4	D4	D4	S6
1	D4	D4	D5	D5	D5	D5	X
1	D5	D5	D5	D5	D6	D6	S8
1	D6	D6	D6	D6	D6	D6	S9

NOTE: In order to maintain compatibility with Recommendation X.30 (I.461), for the 600 bit/s user rate bit E7 is coded to enable the 4x80 bit multiframe synchronisation. To this end, E7 in the fourth 80 bit frame is set to binary '0'. See Table 6 of ITU-T Recommendation V.110(09/92).

Figure 9: a) Modified CCITT V.110 36 bit frame for 600 bit/s transparent data and b) the corresponding intermediate rate frame at 8 kbit/s

D1	D2	D3	D4	D5	D6	T1
D7	D8	D9	D10	D11	D12	T2
D13	D14	D15	D16	D17	D18	T3
D19	D20	D21	D22	D23	D24	T4
D25	D26	D27	D28	D29	D30	D31
D32	D33	D34	D35	D36	D37	D38
D39	D40	D41	D42	D43	D44	D45
D46	D47	D48	D49	D50	D51	D52
D53	D54	D55	D56			

Figure 10: Modified CCITT V.110 60 bit frame for 11,2 kbit/s partial rate

D1	D2	D3	D4	D5	D6	D'1
D7	D8	D9	D10	D11	D12	D'2
D13	D14	D15	D16	D17	D18	D'3
D19	D20	D21	D22	D23	D24	D'4
D'5	D'6	D'7	D'8	D25	D26	D27
D28	D29	D30	D'9	D31	D32	D33
D34	D35	D36	D'10	D37	D38	D39
D40	D41	D42	D'11	D43	D44	D45
D46	D47	D48	D'12			

Figure 11: Modified CCITT V.110 60 bit frame for non-transparent data

0	0	0	0	0	0	0	0
1	D1	D2	D3	D4	D5	D6	S1
1	D7	D8	D9	D10	F	F	X
1	D11	D12	F	F	D13	D14	S3
1	F	F	D15	D16	D17	D18	S4
1	1	0	1	E4	E5	E6	E7
1	D19	D20	D21	D22	D23	D24	S6
1	D25	D26	D27	D28	F	F	X
1	D29	D30	F	F	D31	D32	S8
1	F	F	D33	D34	D35	D36	S9

F=Fill bits, which are set to 1.

Figure 12: The CCITT V.110 80 bit frame for 3.6 kbit/s transparent data (8 kbit/s intermediate rate)

1	D1	D2	D3	D4	D5	D6	S1
0	D7	D8	D9	D10	D11	D12	X
1	D13	D14	D15	D16	D17	D18	S3
1	D19	D20	D21	D22	D23	D24	S4

Figure 13: The CCITT V.110 32 bit 48 kbit/s frame structure (64 kbit/s intermediate rate)

D1	D2	D3	D4	D5	D6	D7	1
D8	D9	D10	D11	D12	D13	D14	1
D15	D16	D17	D18	D19	D20	D21	1
D22	D23	D24	D25	D26	D27	D28	1
D29	D30	D31	D32	D33	D34	D35	1
D36	D37	D38	D39	D40	D41	D42	1
D43	D44	D45	D46	D47	D48	D49	1
D50	D51	D52	D53	D54	D55	D56	1

Figure 14: The CCITT V.110 64 bit 56 kbit/s frame structure (64 kbit/s intermediate rate , option without status bits)

D1	D2	D3	D4	D5	D6	S1
D7	D8	D9	D10	D11	D12	X
D13	D14	D15	D16	D17	D18	S3
D19	D20	D21	D22	D23	D24	S4
E4	E5	E6	E7	1	1	1
1	1	1	S6	1	1	1
1	1	1	X	1	1	1
1	1	1	S8	1	1	1
1	1	1	S9			

Figure 15: Modified CCITT V.110 60 bit frame for a padded 9,6 kbit/s transparent data frame carrying 4,8 kbit/s with padding

D1	D2	D3	D4	D5	D6	T1
D7	D8	D9	D10	D11	D12	T2
D13	D14	D15	D16	D17	D18	T3
D19	D20	D21	D22	D23	D24	T4
D25	D26	D27	D28	D29	D30	D31
D32	D33	D34	D35	D36	D37	D38
D39	D40	1	1	1	1	1
1	1	1	1	1	1	1
1	1	1	1			

Figure 16: Modified CCITT V.110 60 bit frame for a padded 11,2 kbit/s transparent data frame carrying 8.0 kbit/s with padding.

D1	D2	D3	D4	D5	D6
D7	D8	D9	D10	D11	D12
D13	D14	D15	D16	D17	D18
D19	D20	D21	D22	D23	D24
D25	D26	D27	D28	D29	D30
D31	D32	D33	D34	D35	D36

Figure 17: Modified CCITT V.110 36-bit frame received/sent from/to the network at 14,4 kbit/s.

Annex A (informative): Stacks of rate adaptation

A.1 Stacks of rate adaptation for 9,6/4,8 kbit/s single slot operation

For transparent data services, the following stacks of rate adaptation are possible:

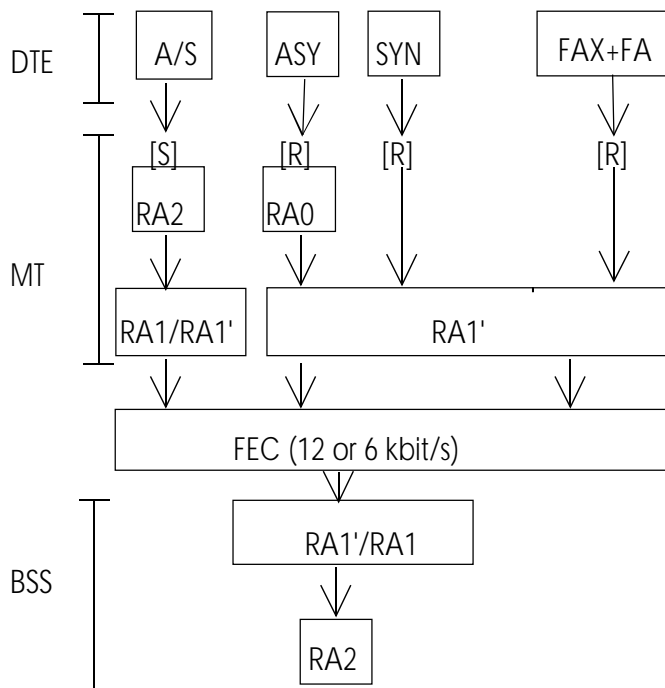

For the non-transparent services, the following stacks of rate adaptation and functions are possible:

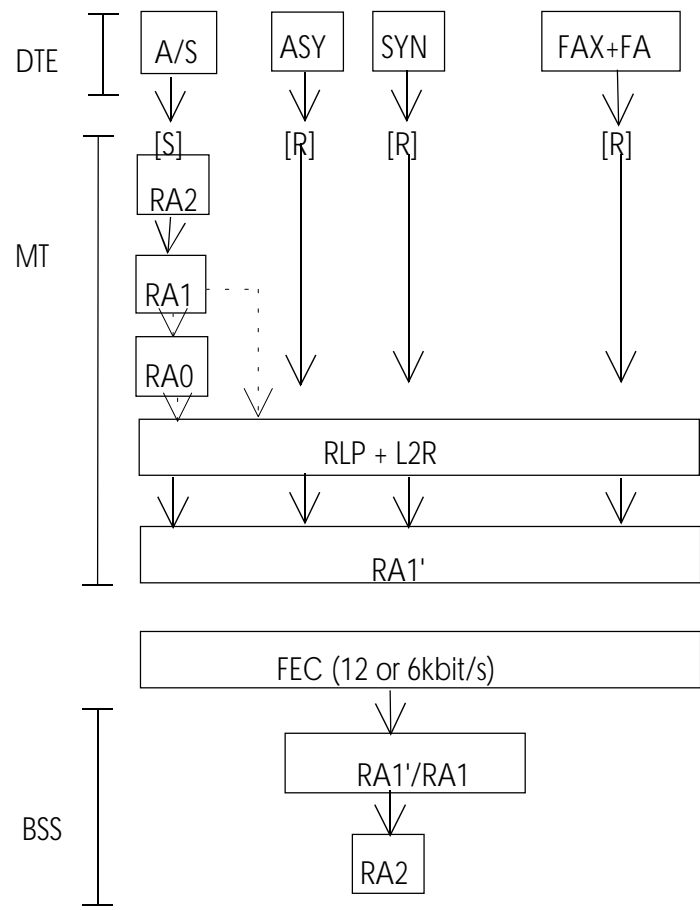

A.2 Stacks of rate adaptation for 14,4 kbit/s single slot operation

For transparent data services, the following stacks of rate adaptation are possible:

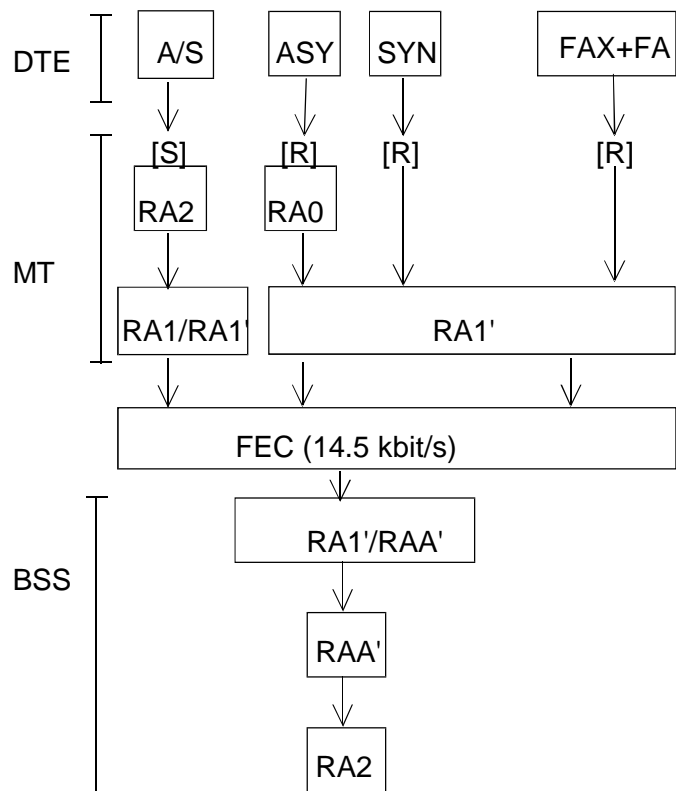

For the non-transparent services, the following stacks of rate adaptation and functions are possible:

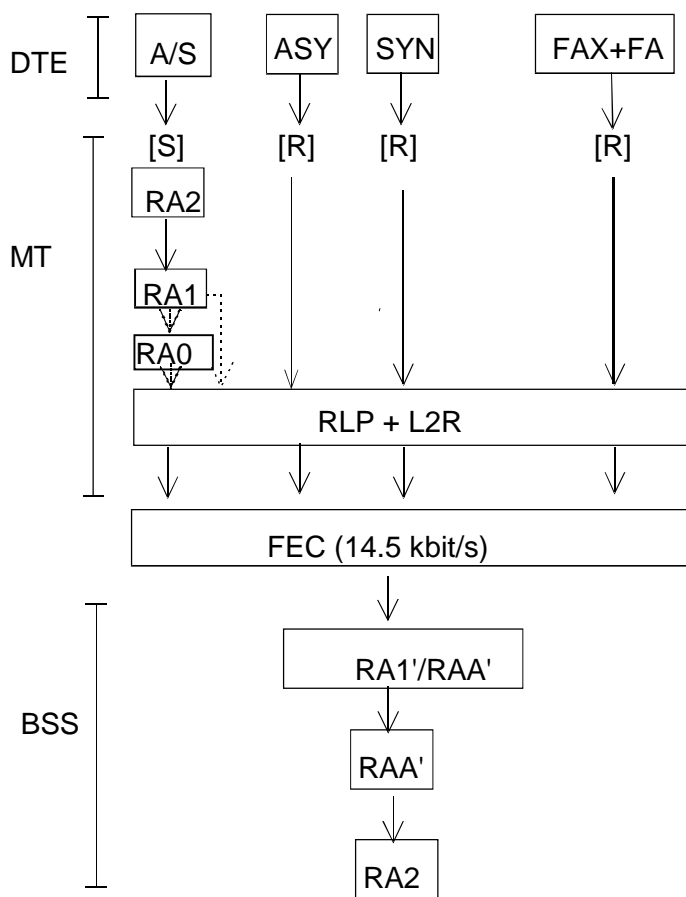

A.3 Stacks of rate adaptation for 9,6/4,8 kbit/s multi slot operation

For transparent data services, the following stacks of rate adaptation are possible:

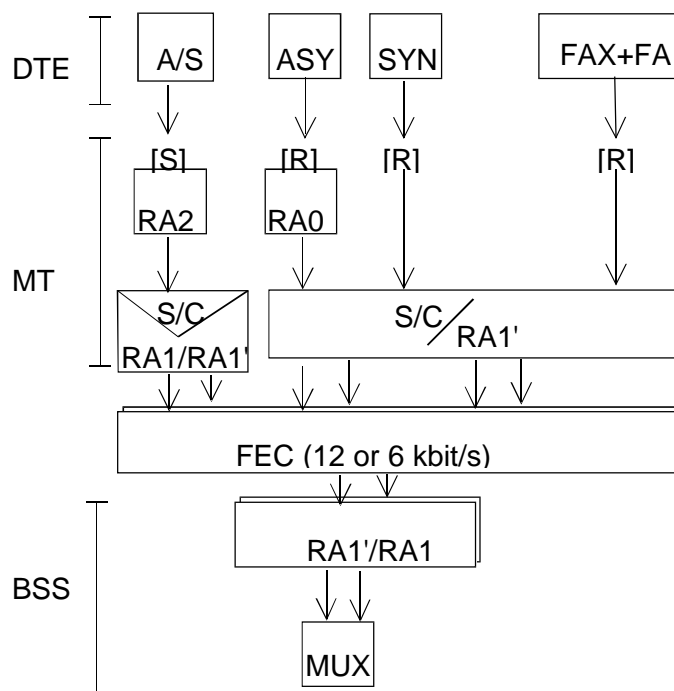

For the non-transparent services, the following stacks of rate adaptation and functions are possible:

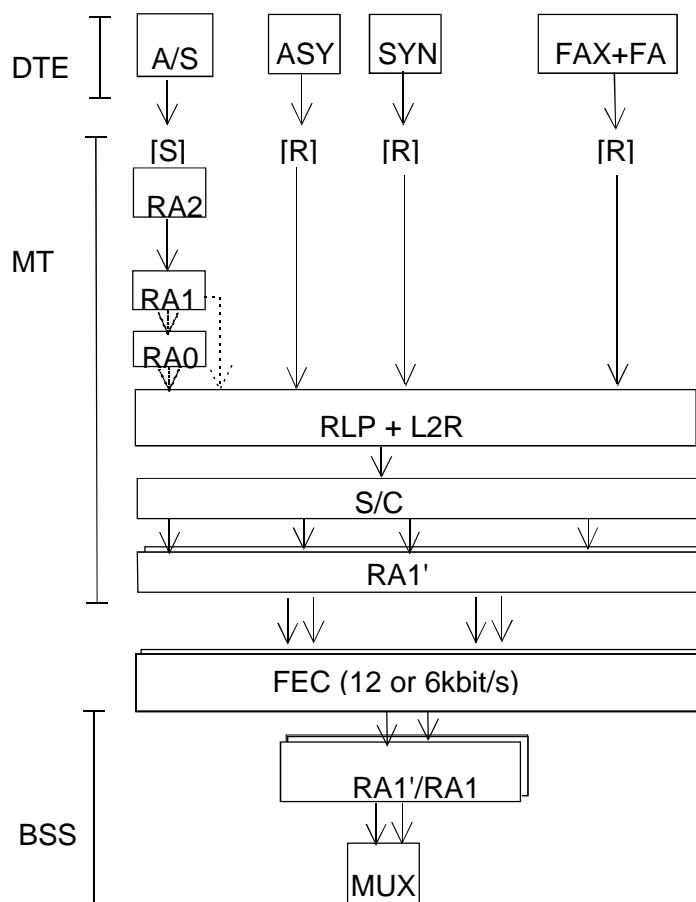

A.4 Stacks of rate adaptation for 14,4 kbit/s multi slot operation

For transparent data services, the following stacks of rate adaptation are possible:

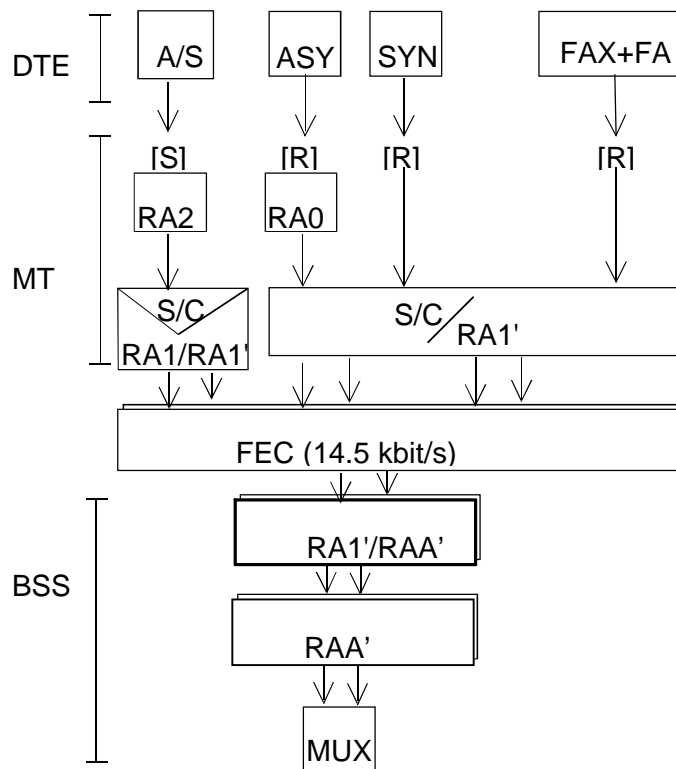

For the non-transparent services, the following stacks of rate adaptation and functions are possible:

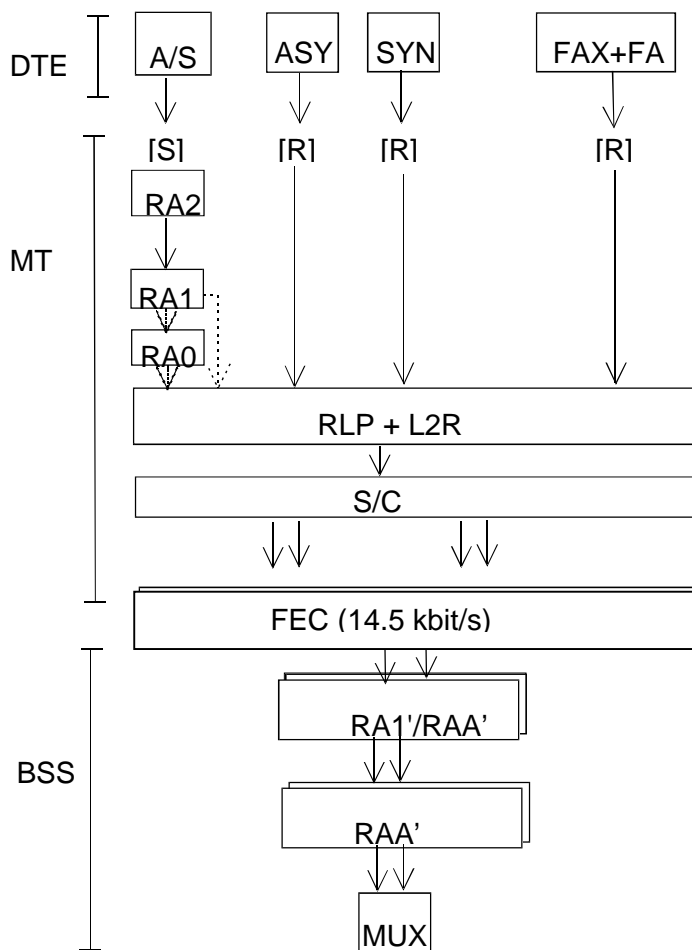

Annex B (informative): An example of mapping Network Independent Clocking information for TCH/F14.4 when the S-interface is deployed

In the following, when data bits are moved forwards or backwards between data frames and blocks, padded bit positions are skipped, and the data is moved between bit positions occupied by data bits, i.e. data bit positions.

Negative compensation:

- a) From overall data stream to substreams

When the data is mapped from the V.110-frames to the radio interface blocks, the 'extra null bit' (subclause 5.1.1) is dropped and remapped to the first data bit position of radio interface block number 28, which is the block carrying the fifth N-bit in the 31-block multiframe structure.

- b) From substreams to overall data stream

When a radio interface block carrying the fifth bit of an NIC-code indicating negative compensation is received, the receiver discards the data in the first data bit position of the block.

Positive compensation:

- a) From overall data stream to substreams

When the data is mapped from the V.110-frames to the radio interface blocks, the extra bit — either 0 or 1 — is added to the data flow in the correct position (subclause 5.1.1). This means that the 36-bit frame (inside a radio-interface block) in which this has taken place has a bit overflow; this overflow is carried over to the next frames and to the next radio interface blocks; i.e. bit position 1 of the following frame/block would carry the user data bit that originally was the last non-padded bit in the previous frame/block. The overflow is halted in the block carrying the second bit of the NIC-code; the value of the N-bit carried by this block (by bit M2) is set to either 1 or 0 depending on the value of the bit that would be mapped to the first data bit position of the block if the overflow carry over would continue. If this bit is a 1, the N-bit is set to 0 (positive compensation of a 1); if the bit is a 0, the N-bit is set to 1 (positive compensation of a 0). The bit that has been thus coded is not mapped to the first data bit position but carried by the NIC-code. The following bits are moved up by one data bit position.

- b) From substreams to overall data stream

When a radio interface block indicating positive compensation is received from the radio, the NIC is decoded and the data is mapped into the V.110-frames in the overall data stream. Decoding the NIC means that an 'extra bit' emerges. This bit takes its real place in the overall data stream (before the first data bit position of the block carrying the second bit of the NIC-code.) Thus a bit overflow results. This overflow is carried over the V.110-frames until an air-interface block associated with the M2-bit carrying the fifth bit of the NIC-code (subclause 5.1.1) has been fully received. After such block is received the next two suitable V.110-frames carry an NIC-code; the overflow of one bit which has been carried over a sequence of V.110-frames halts here as the second V.110-frame carries one extra bit; the value of the D-bit following the E4-E7 sequence in the V.110-frame is carried by the NIC-code and the following data bits are moved up by one step in the V.110-frame.

Annex C (informative): Change Request History

SMG#	SPEC	CR	PHA	VERS	NEW_VE	SUBJECT
s21	04.21	A004	2+	5.0.0	5.1.0	HSCSD
s21	04.21	A005	2+	5.0.0	5.1.0	Support of 14.4 kbit/s (Radio interface related)
s22	04.21	A006	2+	5.1.1	5.2.0	Corrections and improvements for 14.4 kbit/s
s22	04.21	A007	2+	5.1.1	5.2.0	Clarification to HSCSD
s23	04.21	A008	R96	5.2.0	5.3.0	Editorial changes, rate adaptation procedure
s24	04.21	A009	R96	5.3.0	5.4.0	Removal of 2*14.4=19.2 Transparent configuration
s24	04.21	A010	R96	5.3.0	5.4.0	Update of the protocol stack models in Annex A
s25	04.21	A011	R96	5.4.0	5.5.0	Clarification to the association between channel codings and intermediate rates
s27	04.21	A013	R96	5.5.0	5.6.0	Break handling
SMG#27					6.0.0	Release 1997 version

History

Document history				
Edition 1	December 1996	Unified Approval Procedure	UAP 60:	1996-12-02 to 1997-03-28
Edition 2	April 1997	One-step Approval Procedure	OAP 9731:	1997-04-04 to 1997-08-01
Edition 1	May 1997	Publication as ETS 300 945		
Edition 2	August 1997	Publication as ETS 300 945		
Edition 3	August 1997	One-step Approval Procedure	OAP 9752:	1997-08-29 to 1997-12-26
Edition 4	November 1997	One-step Approval Procedure	OAP 9813:	1997-11-28 to 1998-03-27
Edition 3	January 1998	Publication as ETS 300 945		
Edition 5	February 1998	One-step Approval Procedure	OAP 9824:	1998-02-13 to 1998-06-12
Edition 4	March 1998	Publication as ETS 300 945		
Edition 6	May 1998	One-step Approval Procedure	OAP 9841:	1998-05-20 to 1998-10-16
Edition 5	July 1998	Publication as ETS 300 945		
Edition 6	October 1998	Publication as ETS 300 945		
Edition 7	November 1998	One-step Approval Procedure	OAP 9911:	1998-11-13 to 1999-03-12
Edition 7	March 1999	Publication as ETS 300 945		
V6.0.0	April 1999	One-step Approval Procedure	OAP 9935:	1999-04-30 to 1999-08-27
V6.0.1	September 1999	Publication		