

Draft **ETSI EN 300 720** V2.1.0 (2015-12)



**Ultra-High Frequency (UHF) on-board vessels  
communications systems and equipment;  
Harmonised Standard covering the essential requirements  
of article 3.2 of the Directive 2014/53/EU**

---

Reference

REN/ERM-TG26-136

---

Keywords

Harmonised Standard, maritime, radio, UHF

**ETSI**

650 Route des Lucioles  
F-06921 Sophia Antipolis Cedex - FRANCE

Tel.: +33 4 92 94 42 00 Fax: +33 4 93 65 47 16

Siret N° 348 623 562 00017 - NAF 742 C  
Association à but non lucratif enregistrée à la  
Sous-Préfecture de Grasse (06) N° 7803/88

---

**Important notice**

The present document can be downloaded from:  
<http://www.etsi.org/standards-search>

The present document may be made available in electronic versions and/or in print. The content of any electronic and/or print versions of the present document shall not be modified without the prior written authorization of ETSI. In case of any existing or perceived difference in contents between such versions and/or in print, the only prevailing document is the print of the Portable Document Format (PDF) version kept on a specific network drive within ETSI Secretariat.

Users of the present document should be aware that the document may be subject to revision or change of status. Information on the current status of this and other ETSI documents is available at  
<http://portal.etsi.org/tb/status/status.asp>

If you find errors in the present document, please send your comment to one of the following services:  
<https://portal.etsi.org/People/CommitteeSupportStaff.aspx>

---

**Copyright Notification**

No part may be reproduced or utilized in any form or by any means, electronic or mechanical, including photocopying and microfilm except as authorized by written permission of ETSI.

The content of the PDF version shall not be modified without the written authorization of ETSI.  
The copyright and the foregoing restriction extend to reproduction in all media.

© European Telecommunications Standards Institute 2015.  
All rights reserved.

**DECT™**, **PLUGTESTS™**, **UMTS™** and the ETSI logo are Trade Marks of ETSI registered for the benefit of its Members.  
**3GPP™** and **LTE™** are Trade Marks of ETSI registered for the benefit of its Members and of the 3GPP Organizational Partners.  
**GSM®** and the GSM logo are Trade Marks registered and owned by the GSM Association.

# Contents

Intellectual Property Rights .....	6
Foreword.....	6
Modal verbs terminology.....	6
1 Scope .....	7
2 References .....	7
2.1 Normative references .....	7
2.2 Informative references.....	7
3 Definitions, symbols and abbreviations .....	8
3.1 Definitions .....	8
3.2 Symbols.....	8
3.3 Abbreviations .....	8
4 General requirements .....	8
4.1 Construction .....	8
4.2 Frequencies.....	8
4.3 Controls .....	9
4.4 Switching time.....	10
4.5 Safety precautions .....	10
4.6 Class of emission and modulation characteristics .....	10
4.7 Batteries for portable equipment .....	10
4.8 Loudspeaker and microphone.....	10
4.9 Labelling.....	10
4.10 Equipment documentation.....	10
5 Test conditions, power sources and ambient temperatures .....	11
5.1 Normal end extreme test conditions .....	11
5.2 Test power source.....	11
5.3 Normal test conditions.....	11
5.3.1 Normal temperature and humidity .....	11
5.3.2 Normal test voltage .....	11
5.3.2.1 Battery power source.....	11
5.3.2.2 Other power sources.....	11
5.4 Extreme test conditions .....	11
5.4.1 Extreme temperatures .....	11
5.4.1.1 Upper extreme temperature .....	11
5.4.1.2 Lower extreme temperature .....	11
5.4.2 Extreme test power supply values.....	12
5.4.2.1 Upper extreme test voltage - Portable equipment .....	12
5.4.2.2 Lower extreme test voltage - Portable equipment .....	12
5.4.2.3 Extreme test voltages - Other equipment .....	12
5.5 Procedure for tests at extreme temperatures.....	12
6 General conditions of measurement .....	13
6.1 Test connections .....	13
6.2 Arrangements for test signals .....	13
6.2.1 Test signals applied to the transmitter input .....	13
6.2.2 Test signals applied to the antenna terminal .....	13
6.3 Receiver mute or squelch facility .....	13
6.4 Normal test modulation .....	13
6.5 Artificial antenna.....	13
6.6 Test channels .....	13
7 Environmental tests .....	14
7.1 Procedure.....	14
7.2 Performance check .....	14
7.3 Drop test on to a hard surface - Portable equipment .....	14
7.3.1 Definition.....	14
7.3.2 Method of measurement .....	14

7.3.3	Requirement.....	15
7.4	Temperature tests .....	15
7.4.1	General.....	15
7.4.2	Dry heat .....	15
7.4.2.1	Method of measurement.....	15
7.4.2.2	Requirement .....	15
7.4.3	Damp heat.....	15
7.4.3.1	Method of measurement.....	15
7.4.3.2	Requirement .....	15
8	Transmitter .....	16
8.1	Frequency error .....	16
8.1.1	Definition.....	16
8.1.2	Method of measurement .....	16
8.1.3	Limits.....	16
8.2	Maximum effective radiated power.....	16
8.2.1	Definition.....	16
8.2.2	Method of measurement .....	16
8.2.3	Limit .....	17
8.3	Frequency deviation .....	17
8.3.1	Definition.....	17
8.3.2	Maximum frequency deviation.....	17
8.3.2.1	Method of measurement.....	17
8.3.2.2	Limit.....	17
8.3.3	Frequency deviation at modulation frequencies above 3 kHz .....	17
8.3.3.1	Method of measurement.....	17
8.3.3.2	Limits .....	18
8.4	Limitation characteristics of the modulator.....	18
8.4.1	Definition.....	18
8.4.2	Method of measurement .....	18
8.4.3	Limit .....	19
8.5	Sensitivity of the modulator, including microphone (except for repeater equipment) .....	19
8.5.1	Definition.....	19
8.5.2	Method of measurement .....	19
8.5.3	Limit .....	19
8.6	Audio frequency response .....	19
8.6.1	Definition.....	19
8.6.2	Method of measurement .....	19
8.6.3	Limit .....	20
8.7	Audio frequency harmonic distortion of the emission.....	20
8.7.1	Definition.....	20
8.7.2	Method of measurement .....	20
8.7.3	Limit .....	21
8.8	Adjacent channel power .....	21
8.8.1	Definition.....	21
8.8.2	Method of measurement .....	21
8.8.3	Limit .....	21
8.9	Residual modulation of the transmitter .....	21
8.9.1	Definition.....	21
8.9.2	Method of measurement .....	22
8.9.3	Limit .....	22
8.10	Transient frequency behaviour of the transmitter.....	22
8.10.1	Definition.....	22
8.10.2	Method of measurement .....	22
8.10.3	Limits.....	24
8.11	Conducted spurious emissions conveyed to the antenna.....	25
8.11.1	Definition.....	25
8.11.2	Method of measurement .....	25
8.11.3	Limit .....	25
8.12	Cabinet radiation and conducted spurious emissions other than those conveyed to the antenna .....	25
8.12.1	Definitions .....	25
8.12.2	Method of measurement .....	25

8.12.3	Limits.....	26
9	Receiver.....	27
9.1	Harmonic distortion and rated audio frequency output power .....	27
9.1.1	Definition.....	27
9.1.2	Methods of measurement.....	27
9.1.3	Limits.....	27
9.2	Audio frequency response .....	27
9.2.1	Definition.....	27
9.2.2	Method of measurement .....	27
9.2.3	Limits.....	28
9.3	Maximum usable sensitivity.....	29
9.3.1	Definition.....	29
9.3.2	Method of measurement .....	29
9.3.3	Limits.....	29
9.4	Co-channel rejection.....	29
9.4.1	Definition.....	29
9.4.2	Method of measurement .....	29
9.4.3	Limit .....	30
9.5	Adjacent channel selectivity.....	30
9.5.1	Definition.....	30
9.5.2	Method of measurement .....	30
9.5.3	Limits.....	30
9.6	Spurious response rejection.....	30
9.6.1	Definition.....	30
9.6.2	Method of measurement .....	30
9.6.3	Limit .....	31
9.7	Intermodulation response .....	31
9.7.1	Definition.....	31
9.7.2	Method of measurement .....	31
9.7.3	Limit .....	31
9.8	Blocking or desensitization .....	31
9.8.1	Definition.....	31
9.8.2	Method of measurement .....	31
9.8.3	Limit .....	32
9.9	Conducted spurious emissions conveyed to the antenna.....	32
9.9.1	Definition.....	32
9.9.2	Method of measurement .....	32
9.9.3	Limit .....	32
9.10	Radiated spurious emissions.....	32
9.10.1	Definition.....	32
9.10.2	Method of measurements.....	32
9.10.3	Limit .....	33
10	Testing for compliance with technical requirements.....	33
10.1	Environmental conditions for testing .....	33
10.2	Interpretation of the measurement results .....	33
<b>Annex A (normative):</b>	<b>Relationship between the present document and the essential requirements of Directive 2014/53/EU .....</b>	<b>35</b>
<b>Annex B (normative):</b>	<b>Measuring receiver for adjacent channel power measurement.....</b>	<b>37</b>
B.1	Power measuring receiver specification.....	37
B.1.0	General .....	37
B.1.1	IF filter .....	37
B.1.2	Attenuation indicator.....	38
B.1.3	rms value indicator .....	38
B.1.4	Oscillator and amplifier.....	38
History	.....	39

---

## Intellectual Property Rights

IPRs essential or potentially essential to the present document may have been declared to ETSI. The information pertaining to these essential IPRs, if any, is publicly available for **ETSI members and non-members**, and can be found in ETSI SR 000 314: "*Intellectual Property Rights (IPRs); Essential, or potentially Essential, IPRs notified to ETSI in respect of ETSI standards*", which is available from the ETSI Secretariat. Latest updates are available on the ETSI Web server (<http://ipr.etsi.org>).

Pursuant to the ETSI IPR Policy, no investigation, including IPR searches, has been carried out by ETSI. No guarantee can be given as to the existence of other IPRs not referenced in ETSI SR 000 314 (or the updates on the ETSI Web server) which are, or may be, or may become, essential to the present document.

---

## Foreword

This draft Harmonised European Standard (EN) has been produced by ETSI Technical Committee Electromagnetic compatibility and Radio spectrum Matters (ERM), and is now submitted for the combined Public Enquiry and Vote phase of the ETSI standards EN Approval Procedure.

The present document has been prepared in reply to the Commission's standardisation request Commission Implementing Decision C(2015) 5376 final of 04.08.2015 to provide a means of conforming to the essential requirements of Directive 2014/53/EU on the harmonisation of the laws of the Member States relating to the making available on the market of radio equipment.

Once the present document is cited in the Official Journal of the European Union under that Directive, compliance with the normative clauses of the present document given in table A.1 confers, within the limits of the scope of the present document, a presumption of conformity with the corresponding essential requirements of that Directive, and associated EFTA regulations.

<b>Proposed national transposition dates</b>	
Date of latest announcement of this EN (doa):	3 months after ETSI publication
Date of latest publication of new National Standard or endorsement of this EN (dop/e):	6 months after doa
Date of withdrawal of any conflicting National Standard (dow):	18 months after doa

---

## Modal verbs terminology

In the present document "**shall**", "**shall not**", "**should**", "**should not**", "**may**", "**need not**", "**will**", "**will not**", "**can**" and "**cannot**" are to be interpreted as described in clause 3.2 of the [ETSI Drafting Rules](#) (Verbal forms for the expression of provisions).

"**must**" and "**must not**" are **NOT** allowed in ETSI deliverables except when used in direct citation.

---

# 1 Scope

The present document specifies the minimum technical characteristics required for UHF on board vessels radio equipment and systems operating on frequencies allocated to the maritime mobile services by the ITU Radio Regulations [i.1].

The present document contains requirements to demonstrate that "*... Radio equipment shall be so constructed that it both effectively uses and supports the efficient use of radio spectrum in order to avoid harmful interference*" [i.3].

---

## 2 References

### 2.1 Normative references

References are either specific (identified by date of publication and/or edition number or version number) or non-specific. For specific references, only the cited version applies. For non-specific references, the latest version of the referenced document (including any amendments) applies.

Referenced documents which are not found to be publicly available in the expected location might be found at <http://docbox.etsi.org/Reference>.

NOTE: While any hyperlinks included in this clause were valid at the time of publication, ETSI cannot guarantee their long term validity.

The following referenced documents are necessary for the application of the present document.

- [1] Recommendation ITU-R M.1174-2 (2004): "Technical characteristics of equipment used for on-board vessel communications in the bands between 450 and 470 MHz".
- [2] Recommendation ITU-T O.41 (1994): "Psophometer for use on telephone-type circuits".
- [3] ISO 25862:2009: "Ships and marine technology -- Marine magnetic compasses, binnacles and azimuth reading devices".
- [4] ETSI TS 103 052 (V1.1.1) (03-2011): "Electromagnetic compatibility and Radio spectrum Matters (ERM); Radiated measurement methods and general arrangements for test sites up to 100 GHz".

### 2.2 Informative references

References are either specific (identified by date of publication and/or edition number or version number) or non-specific. For specific references, only the cited version applies. For non-specific references, the latest version of the referenced document (including any amendments) applies.

NOTE: While any hyperlinks included in this clause were valid at the time of publication, ETSI cannot guarantee their long term validity.

The following referenced documents are not necessary for the application of the present document but they assist the user with regard to a particular subject area.

- [i.1] ITU Radio Regulations (2012).
- [i.2] Recommendation ITU-R SM.332-4: "Selectivity of receivers".
- [i.3] Directive 2014/53/EU of the European Parliament and of the Council of 16 April 2014 on the harmonisation of the laws of the Member States relating to the making available on the market of radio equipment and repealing Directive 1999/5/EC.
- [i.4] ETSI TR 100 028-1 (V1.4.1) (12-2001): "Electromagnetic compatibility and Radio spectrum Matters (ERM); Uncertainties in the measurement of mobile radio equipment characteristics; Part 1".

- [i.5] ETSI TR 100 028-2 (V1.4.1) (12-2001): "Electromagnetic compatibility and Radio spectrum Matters (ERM); Uncertainties in the measurement of mobile radio equipment characteristics; Part 2".

## 3 Definitions, symbols and abbreviations

### 3.1 Definitions

For the purposes of the present document, the following terms and definitions apply:

**integral antenna:** antenna designed as a fixed part of the equipment, without the use of an external connector and as such which cannot be disconnected from the equipment by the user

**modulation index:** ratio between the frequency deviation and the modulation frequency

### 3.2 Symbols

For the purposes of the present document, the following symbols apply:

dBa                      Relative to  $2 \times 10^{-5}$  Pa

### 3.3 Abbreviations

For the purposes of the present document, the following abbreviations apply:

ad	amplitude difference
CSP	Channel Spacing Parameters
EFTA	European Free Trade Association
emf	electro-motive force
EU	European Union
fd	frequency difference
IF	Intermediate Frequency
ISO	International Organization for Standardization
ITU-R	International Telecommunication Union - Radiocommunication Sector
ITU-T	International Telecommunication Union - Telecommunication Sector
MPFD	Maximum Permissible Frequency Deviation
PEP	Peak Envelope Power
RF	Radio Frequency
rms	root mean square
SINAD	signal + noise + distortion / noise + distortion
UHF	Ultra High Frequency

## 4 General requirements

### 4.1 Construction

The mechanical and electrical construction and finish of the equipment shall conform in all respects to good engineering practice and the equipment shall be suitable for use on board vessels.

For portable equipment the colour shall be neither orange nor yellow.

### 4.2 Frequencies

The equipment shall operate either on single-frequency or two-frequency simplex channels on those frequencies specified in Recommendation ITU-R M.1174-3 [1].

Single frequency simplex channels shall be in accordance with table 1.

Additional channels for 12,5 kHz equipment shall be in accordance with table 2.



Two frequency simplex channels for use with a repeater shall be in accordance with table 3.

**Table 1: Single frequency simplex channels (25 kHz or 12,5 kHz use)**

Channel designator	CSP	Frequency
Channel A	25 kHz	467,525 MHz
Channel A*	12,5 kHz	
Channel B	25 kHz	467,550 MHz
Channel B*	12,5 kHz	
Channel C	25 kHz	467,575 MHz
Channel C*	12,5 kHz	
Channel D	25 kHz	457,525 MHz
Channel D*	12,5 kHz	
Channel E	25 kHz	457,550 MHz
Channel E*	12,5 kHz	
Channel F	25 kHz	457,575 MHz
Channel F*	12,5 kHz	

**Table 2: Additional channels for 12,5 kHz equipment**

Channel designator	CSP	Frequency
Channel M*	12,5 kHz	467,5375 MHz
Channel N*	12,5 kHz	467,5625 MHz
Channel O*	12,5 kHz	457,5375 MHz
Channel P*	12,5 kHz	457,5625 MHz

**Table 3: Two-frequency simplex channels for use with repeater only**

Channel designator	CSP	Repeater Rx frequency	Repeater Tx frequency
Channel G	25 kHz	467,525 MHz	457,525 MHz
Channel G*	12,5 kHz		
Channel H	25 kHz	467,550 MHz	457,550 MHz
Channel H*	12,5 kHz		
Channel J	25 kHz	467,575 MHz	457,575 MHz
Channel J*	12,5 kHz		
Channel K*	12,5 kHz	467,5375 MHz	457,5375 MHz
Channel L*	12,5 kHz	467,5625 MHz	457,5625 MHz

Designators for 12,5 kHz channels (with the \*) means that the equipment shall show that the operation is 12,5 kHz by visual or other means.

Independent selection of transmitting and receiving frequencies shall not be possible.

The equipment shall be fitted with at least one single-frequency simplex channel, the frequency of which shall be 457,525 MHz.

It shall not be possible to transmit during channel-switching operations.

## 4.3 Controls

The equipment shall have the following controls:

- a channel selector which shall indicate the designator of the channel to which the equipment is set;
- on/off switch for the equipment with visual indication that the equipment is switched on;
- a manual non-locking, push-to-talk switch to operate the transmitter (except for repeater equipment);
- an audio-frequency power volume control (except for repeater equipment).

The user shall not have access to any control which, if wrongly set, might impair the technical characteristics of the equipment.

## 4.4 Switching time

The channel switching arrangements shall be such that the time necessary to change over from using one of the channels to using any other channel does not exceed 5 seconds.

The time necessary to change over from transmission to reception and vice versa, shall not exceed 0,3 seconds.

## 4.5 Safety precautions

Provision shall be made for protecting equipment from the effects of excessive current or voltage. Means shall be incorporated to prevent reversal of polarity of the battery power supply.

Equipment with an antenna socket shall not be damaged by the effect of open-circuit or short-circuit of the antenna socket for a period of at least 5 minutes.

The manufacturer shall declare the compass safe distance according to ISO 25862 [3].

## 4.6 Class of emission and modulation characteristics

The equipment shall use phase modulation, G3E (frequency modulation with a pre-emphasis of 6 dB/octave).

The equipment shall be designed to operate with a channel spacing of 25 kHz or 12,5 kHz or both.

## 4.7 Batteries for portable equipment

The battery may be an integral part of the equipment.

Primary and/or secondary batteries may be used.

Provisions shall be made for replacing the battery easily.

If the equipment is fitted with secondary batteries, a suitable battery charger shall be recommended by the manufacturer.

## 4.8 Loudspeaker and microphone

The equipment shall be provided with a microphone and a loudspeaker which may be combined (except for repeater equipment).

In the transmit condition the output of the receiver shall be muted (except for repeater equipment).

## 4.9 Labelling

All controls shall be clearly labelled. The labelling shall include:

- the name of the manufacturer and his trademark;
- the type number and serial number of the equipment; and
- the compass safe distance.

## 4.10 Equipment documentation

For the purpose of conformance testing in accordance with the present document, adequate technical and operational documentation shall be supplied with the equipment.

---

## 5 Test conditions, power sources and ambient temperatures

### 5.1 Normal and extreme test conditions

Tests shall be made under normal test conditions and also, where stated, under extreme test conditions.

### 5.2 Test power source

Unless otherwise stated, the battery of the equipment shall be replaced by a test power source capable of producing normal and extreme test voltages as specified in clauses 5.3.2 and 5.4.2.

The voltage of the power source shall be measured at the input terminal of the equipment.

During testing, the power source voltage shall be maintained within a tolerance of  $\pm 3$  % relative to the voltage level at the beginning of each test.

### 5.3 Normal test conditions

#### 5.3.1 Normal temperature and humidity

The normal temperature and humidity conditions for tests shall be a combination of temperature and humidity within the following limits:

- temperature: +15 °C to +35 °C;
- relative humidity: 20 % to 75 %.

#### 5.3.2 Normal test voltage

##### 5.3.2.1 Battery power source

Where the equipment is designed to operate from a battery, the normal test voltage shall be the nominal voltage of the battery.

##### 5.3.2.2 Other power sources

For operation from other power sources the normal test voltage shall be that declared by the manufacturer.

## 5.4 Extreme test conditions

### 5.4.1 Extreme temperatures

#### 5.4.1.1 Upper extreme temperature

Tests at the upper extreme temperature shall be made at +55 °C.

#### 5.4.1.2 Lower extreme temperature

Tests at the lower extreme temperature shall be made at -20 °C.

## 5.4.2 Extreme test power supply values

### 5.4.2.1 Upper extreme test voltage - Portable equipment

The upper extreme test voltage shall be declared by the manufacturer and shall not be lower than the following:

- when using primary batteries, the voltage corresponding to the voltage that a fresh battery gives at the upper extreme temperature when loaded with a load equal to that of the equipment in the muted receive condition;
- when using secondary batteries, the voltage corresponding to the voltage that a fully charged battery gives at the upper extreme temperature when loaded with a load equal to that of the equipment in the muted receive condition.

### 5.4.2.2 Lower extreme test voltage - Portable equipment

The lower extreme test voltage shall be declared by the manufacturer and shall not be higher than the following:

- when using primary batteries, 0,85 times the voltage that a fresh battery gives at the lower extreme temperature when loaded with a load equal to that of the equipment in the muted receive condition;
- when using secondary batteries, 0,85 times the voltage that a fully charged battery gives at the lower extreme temperature when loaded with a load equal to that of the equipment in the muted receive condition.

### 5.4.2.3 Extreme test voltages - Other equipment

For operation from other sources the extreme test voltages shall be those declared by the manufacturer.

## 5.5 Procedure for tests at extreme temperatures

The equipment shall be placed in the test chamber at normal temperature. The maximum rate of rising or reducing the temperature of the chamber shall be 1 °C/minute. The equipment shall be switched off during the temperature-stabilizing periods.

Before conducting tests at extreme temperatures, the equipment in the test chamber shall have reached thermal equilibrium and be subjected to the extreme temperature for a period of 10 hours to 16 hours.

For tests at the lower extreme temperature, the equipment shall then be switched on to the standby or receive condition for one minute, after which the relevant tests shall be performed.

For tests at the higher extreme temperature, the equipment shall then be switched on in the high power transmit condition for 5 minutes followed by 5 minutes in the receive condition, after which the relevant tests shall be performed.

The temperature of the chamber shall be maintained at the extreme temperatures for the whole duration of the performance tests.

At the end of the test, and with the equipment still in the chamber, the chamber shall be brought to room temperature in not less than one hour. The equipment shall then be exposed to normal room temperature and humidity for not less than three hours or until moisture has dispersed, whichever is the longer, before the next test is carried out. Alternatively, observing the same precautions, the equipment may be returned directly to the conditions required for the start of the next tests.

---

## 6 General conditions of measurement

### 6.1 Test connections

For the purpose of testing, suitable connections to the following test points shall be made available:

- the antenna terminal for 50  $\Omega$  connection (for equipment without an external antenna connector a permanent internal or a temporary internal 50  $\Omega$  RF connector which allows access to the transmitter output and the receiver input shall be available);
- the transmitter audio input(s);
- the receiver audio output(s);
- the push-to-talk switch;
- the battery terminals for test power source connections.

### 6.2 Arrangements for test signals

#### 6.2.1 Test signals applied to the transmitter input

For the purpose of tests, the transmitter internal microphone shall be disconnected and an audio frequency signal generator shall be applied to the transmitter audio input terminals.

#### 6.2.2 Test signals applied to the antenna terminal

Test signal generators shall be connected to the antenna terminal in such a way that the impedance presented to the receiver input is 50  $\Omega$ , irrespective of whether one or more test signals are applied simultaneously.

The levels of the test signals shall be expressed in terms of the electro-motive force (emf).

The effects of any intermodulation product and noise product in the test signal generators should be negligible.

The nominal frequency of the receiver is the carrier frequency of the selected channel.

### 6.3 Receiver mute or squelch facility

Unless otherwise specified, the receiver squelch facility shall be made inoperative for the duration of the tests.

### 6.4 Normal test modulation

For normal test modulation, the modulation frequency shall be 1 kHz and the frequency deviation shall be:

- $\pm 3$  kHz for 25 kHz channels;
- $\pm 1,5$  kHz for 12,5 kHz channels.

### 6.5 Artificial antenna

When tests are conducted with an artificial antenna, this shall be a 50  $\Omega$  non-reactive, non-radiating load.

### 6.6 Test channels

For equipment operating in both the 457 MHz and 467 MHz bands, tests shall be carried out at the highest and lowest channels within the frequency range of the equipment, unless otherwise stated.

Where only one single channel is required for the test, then any channel available in the equipment may be used.

---

## 7 Environmental tests

### 7.1 Procedure

Environmental tests shall be carried out before any other tests of the same equipment in respect to the other requirements of the present document are performed. The tests shall be carried out in the order they appear in the present document.

Unless otherwise stated, the equipment shall be connected to an electrical power source during the periods for which it is specified that electrical tests shall be carried out. These tests shall be performed using normal test voltage and on one channel only.

### 7.2 Performance check

For the purpose of the present document, the term "performance check" shall be taken to mean:

- for the transmitter:
  - carrier frequency:
    - with the transmitter connected to an artificial antenna (see clause 6.5), the transmitter shall be keyed without modulation. The carrier frequency shall be within  $\pm 2,3$  kHz of the nominal carrier frequency (for equipment operating with 25 kHz channel separations) or  $\pm 1,15$  kHz of the nominal carrier frequency (for equipment operating with 12,5 kHz channel separations);
  - output power:
    - with the transmitter connected to an artificial antenna (see clause 6.5), the transmitter shall be keyed without modulation. With the output power switch set at maximum, the output power shall be measured and this value recorded (Pt). For the purposes of the performance check, the output power shall be within the range of  $P_t \pm 3$  dB when measured into an artificial antenna.
- for the receiver:
  - maximum usable sensitivity:
    - a test signal at the nominal frequency of the receiver modulated with normal test modulation (see clause 6.4) shall be applied to the receiver input. The level of the input signal shall be adjusted until the SINAD at the output of the receiver is 20 dB and the output power is at least the rated output power (see clause 9.1.3). The level of the input signal shall be less than +12 dB $\mu$ V.

### 7.3 Drop test on to a hard surface - Portable equipment

#### 7.3.1 Definition

The immunity against the effects of dropping is the ability of the equipment to maintain the specified mechanical and electrical performance after being subjected to a series of drops on a hard wooden test surface.

#### 7.3.2 Method of measurement

The hard wooden test surface shall consist of a piece of solid hard wood with a minimum thickness of 15 cm and a mass of 30 kg or more.

The test shall consist of a series of 6 drops, one on each surface of the equipment.

During the test the equipment shall be fitted with a suitable set of batteries and antenna but it shall be switched off. The test shall be carried out under normal temperature and humidity conditions.

The height of the lowest part of the equipment under test relative to the test surface at the moment of release shall be 1 m.

If the equipment is to be used with, for example, a separate microphone and/or loudspeaker, the test shall be carried out for those accessories separately.

Following the test, the equipment shall be subjected to a performance check.

### 7.3.3 Requirement

The requirement for the performance check shall be met.

## 7.4 Temperature tests

### 7.4.1 General

The maximum rate of raising or reducing the temperature of the chamber in which the equipment is being tested shall be 1°C/minute.

### 7.4.2 Dry heat

#### 7.4.2.1 Method of measurement

The equipment shall be placed in a chamber of normal temperature. The temperature shall then be raised to and maintained at +70°C ( $\pm 3^\circ\text{C}$ ) for a period of at least 10 hours. After this period any climatic control device provided in the equipment may be switched on and the chamber cooled to +55°C ( $\pm 3^\circ\text{C}$ ). The cooling of the chamber shall be completed within 30 minutes.

The equipment shall then be switched on and shall be kept working continuously for a period of two hours. The transmitter shall be keyed with a duty cycle of one minute transmission and four minutes reception. The equipment shall be subjected to a performance check during the two-hour period.

The temperature of the chamber shall be maintained at +55°C ( $\pm 3^\circ\text{C}$ ) during the two-hour period.

At the end of the test, and with the equipment still in the chamber, the chamber shall be brought to room temperature in not less than one hour. The equipment shall then be exposed to normal room temperature and humidity for not less than three hours before the next test is carried out.

#### 7.4.2.2 Requirement

The requirement for the performance check shall be met.

### 7.4.3 Damp heat

#### 7.4.3.1 Method of measurement

The equipment shall be placed in a chamber at normal room temperature and humidity which, steadily, over a period three hours ( $\pm 30$  minutes), shall be heated from room temperature to +40°C ( $\pm 3^\circ\text{C}$ ) and shall during this period be brought to a relative humidity of 93 % ( $\pm 2$  %) so that excessive condensation is avoided.

30 minutes later the equipment shall be switched on, and shall then be kept working continuously for a period of two hours. The transmitter shall be keyed with a duty cycle of one minute transmission and four minutes reception.

The equipment shall be subjected to a performance check during the two-hour period.

The chamber shall be maintained at a temperature of +40 °C  $\pm 3$  °C and a relative humidity of 93 %  $\pm 2$  % during the two-hour, 30 minutes period.

At the end of the test, and with the equipment still in the chamber, the chamber shall be brought to room temperature in not less than one hour. The equipment shall then be exposed to normal room temperature and humidity for not less than three hours, or until moisture has dispersed, whichever is longer, before the next test is carried out.

#### 7.4.3.2 Requirement

The requirement for the performance check shall be met.

---

## 8 Transmitter

### 8.1 Frequency error

#### 8.1.1 Definition

The frequency error is the difference between the measured carrier frequency and its nominal value.

#### 8.1.2 Method of measurement

The carrier frequency shall be measured in the absence of modulation, with the transmitter connected to an artificial antenna (see clause 6.5). Measurements shall be made under normal test conditions (see clause 5.3) and under extreme test conditions (clauses 5.4.1 and 5.4.2 applied simultaneously).

#### 8.1.3 Limits

The frequency error shall not exceed:

- 2,3 kHz for 25 kHz channels;
- 1,15 kHz for 12,5 kHz channels.

## 8.2 Maximum effective radiated power

### 8.2.1 Definition

The maximum effective radiated power of the transmitter is the maximum value of the output PEP for any condition of modulation radiated in the direction of the maximum field strength by the equipment with its antenna fitted.

### 8.2.2 Method of measurement

On a test site, selected from clause 5 of ETSI TS 103 052 [4], the equipment, with the antenna connected, shall be placed at the specified height on a non-conducting support, in the position closest to normal use as declared by the manufacturer.

The test antenna shall be orientated for vertical polarization and the length of the test antenna shall be chosen to correspond to the frequency of the transmitter.

The output of the test antenna shall be connected to a measuring receiver.

The transmitter shall be switched on and the measuring receiver shall be tuned to the centre frequency of the channel on which the transmitter is intended to operate.

The test antenna shall be raised and lowered through the specified range of height until a maximum signal level is detected on the measuring receiver.

When a fully anechoic test site according to clause 5.2.1.2 of ETSI TS 103 052 [4] is used there is no need to vary the height of the antenna.

The transmitter shall then be rotated through 360° in the horizontal plane until the maximum signal level is detected by the measuring receiver.

The maximum signal level detected by the measuring receiver shall be noted.

The transmitter shall be replaced by a substitution antenna as defined in clause 5.3.2 of ETSI TS 103 052 [4].

The substitution antenna shall be orientated for vertical polarization and the length of the substitution antenna shall be adjusted to correspond to the frequency of the transmitter.

The substitution antenna shall be connected to a calibrated signal generator.

The sensitivity of the measuring receiver shall be increased in accordance with the new input level (change in attenuator setting).



The test antenna shall be raised and lowered through the specified range of height to ensure that the maximum signal is received. When a test site according to clause 5.2.1.2 of ETSI TS 103 052 [4] is used there is no need to vary the height of the antenna.

The input signal to the substitution antenna shall be adjusted to a level that produces the level detected by the measuring receiver, that is equal to the level noted while using the transmitter under test, corrected for the change in the attenuator setting in the measuring receiver.

The input level to the substitution antenna shall be recorded as a power level.

The measurement shall be repeated with the test antenna and the substitution antenna orientated for horizontal polarization.

The measure of the maximum effective radiated power is the larger of the two power levels recorded at the input to the substitution antenna, corrected for the gain of the antenna if necessary.

If an output power switch is fitted it shall be placed in the maximum position.

### 8.2.3 Limit

The maximum effective radiated power shall not exceed 2 Watts.

## 8.3 Frequency deviation

### 8.3.1 Definition

The frequency deviation is the difference between the instantaneous frequency of the modulated radio frequency signal and the carrier frequency in the absence of modulation.

### 8.3.2 Maximum frequency deviation

#### 8.3.2.1 Method of measurement

The frequency deviation shall be measured at the output with the transmitter connected to an artificial antenna (see clause 6.5), by means of a deviation meter capable of measuring the maximum deviation, including that due to any harmonics and intermodulation products which may be generated in the transmitter.

The modulation frequency shall be varied between 100 Hz and 3 kHz. The level of this test signal shall be 20 dB above the level which produces normal test modulation (see clause 6.4). This test shall be carried out with the output power switch set at maximum and then at minimum.

#### 8.3.2.2 Limit

The maximum frequency deviation shall not exceed:

- $\pm 5$  kHz for 25 kHz channels;
- $\pm 2,5$  kHz for 12,5 kHz channels.

### 8.3.3 Frequency deviation at modulation frequencies above 3 kHz

#### 8.3.3.1 Method of measurement

The transmitter shall operate under normal test conditions (see clause 5.3) connected to a load as specified in clause 6.5. The transmitter shall be modulated by the normal test modulation (see clause 6.4). With the input level of the modulating signal being kept constant, the modulation frequency shall be varied between 3 kHz (see note) and 25 kHz and the frequency deviation shall be measured.

NOTE: 2,55 kHz for transmitters intended for 12,5 kHz channel separation.

### 8.3.3.2 Limits

The frequency deviation at modulation frequencies between 3,0 kHz (for equipment operating with 25 kHz channel separations) or 2,55 kHz (for equipment operating with 12,5 kHz channel separation) and 6,0 kHz shall not exceed the frequency deviation at a modulation frequency of 3,0 kHz/2,55 kHz. At 6,0 kHz the deviation shall be not more than 30,0 % of the maximum permissible frequency deviation.

The frequency deviation at modulation frequencies between 6,0 kHz and a frequency equal to the channel separation for which the equipment is intended shall not exceed that given by a linear representation of the frequency deviation (dB) relative to the modulation frequency, starting at the 6,0 kHz limit and having a slope of -14,0 dB per octave. These limits are illustrated in figure 1.

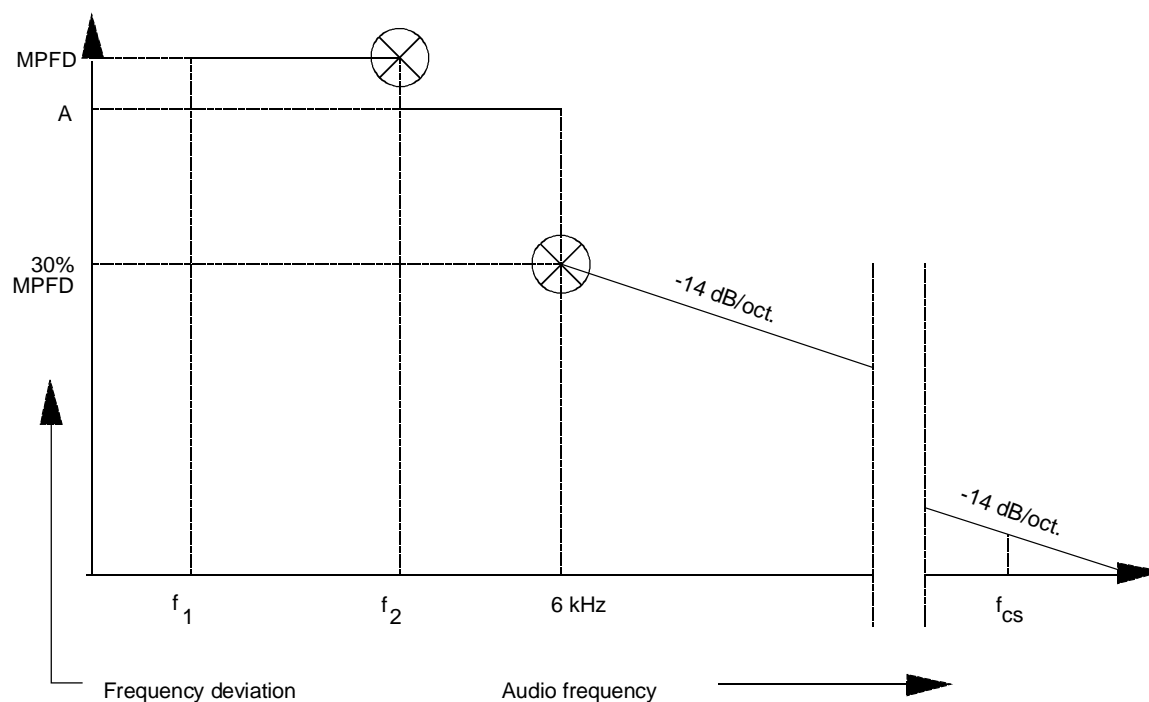

**NOTE:**

**Abbreviations:**

- f1 lowest appropriate frequency.
- f2 3,0 kHz (for 25 kHz channel separation); or  
2,55 kHz (for 12,5 kHz channel separation).
- MPFD Maximum Permissible Frequency Deviation, clause 8.3.2.1.
- A measured frequency deviation at f2.
- fcs frequency equal to channel separation.

**Figure 1: Frequency deviation**

## 8.4 Limitation characteristics of the modulator

### 8.4.1 Definition

This characteristic expresses the capability of the transmitter of being modulated with a deviation approaching the maximum deviation specified in clause 8.3.2.

### 8.4.2 Method of measurement

A modulating signal at a frequency of 1 kHz shall be applied to the transmitter, and its level adjusted so that the frequency deviation is  $\pm 1$  kHz. The level of the modulating signal shall then be increased by 20 dB and the deviation shall again be measured.

### 8.4.3 Limit

The frequency deviation shall be contained between:

- $\pm 3,5$  kHz and  $\pm 5$  kHz for 25 kHz channels;
- $\pm 1,75$  kHz and  $\pm 2,5$  kHz for 12,5 kHz channels.

## 8.5 Sensitivity of the modulator, including microphone (except for repeater equipment)

### 8.5.1 Definition

This sensitivity expresses the capability of the transmitter to produce sufficient modulation when an audio frequency signal corresponding to the normal mean speech level is applied to the microphone.

### 8.5.2 Method of measurement

An acoustic signal with a frequency of 1 kHz and a sound level of 94 dBA shall be applied to the microphone. The resulting frequency deviation shall be measured.

This test shall be carried out on any one channel only (see clause 6.6).

### 8.5.3 Limit

The resulting frequency deviation shall be between:

- $\pm 1,5$  kHz and  $\pm 3$  kHz for 25 kHz channels;
- $\pm 0,75$  kHz and  $\pm 1,5$  kHz for 12,5 kHz channels.

## 8.6 Audio frequency response

### 8.6.1 Definition

The audio frequency response is the frequency deviation of the transmitter as a function of the modulating frequency.

### 8.6.2 Method of measurement

A modulating signal at a frequency of 1 kHz shall be applied to the transmitter and the deviation shall be measured at the output. The audio input level shall be adjusted so that the frequency deviation is  $\pm 1$  kHz. This is the reference point in figure 2 (1 kHz corresponds to 0 dB).

The modulation frequency shall then be varied between 300 Hz and 3 kHz (see note), with the level of the audio frequency signal being kept constant and equal to the value specified above.

The test shall be carried out on any one channel only (see clause 6.6).

NOTE: 2,55 kHz for transmitters intended for 12,5 kHz channel separation.

### 8.6.3 Limit

The audio frequency response shall be within +1 dB and -3 dB of a 6 dB/octave line passing through the reference point (see figure 2). The upper limit frequency shall be 2,55 kHz for 12,5 kHz channels.

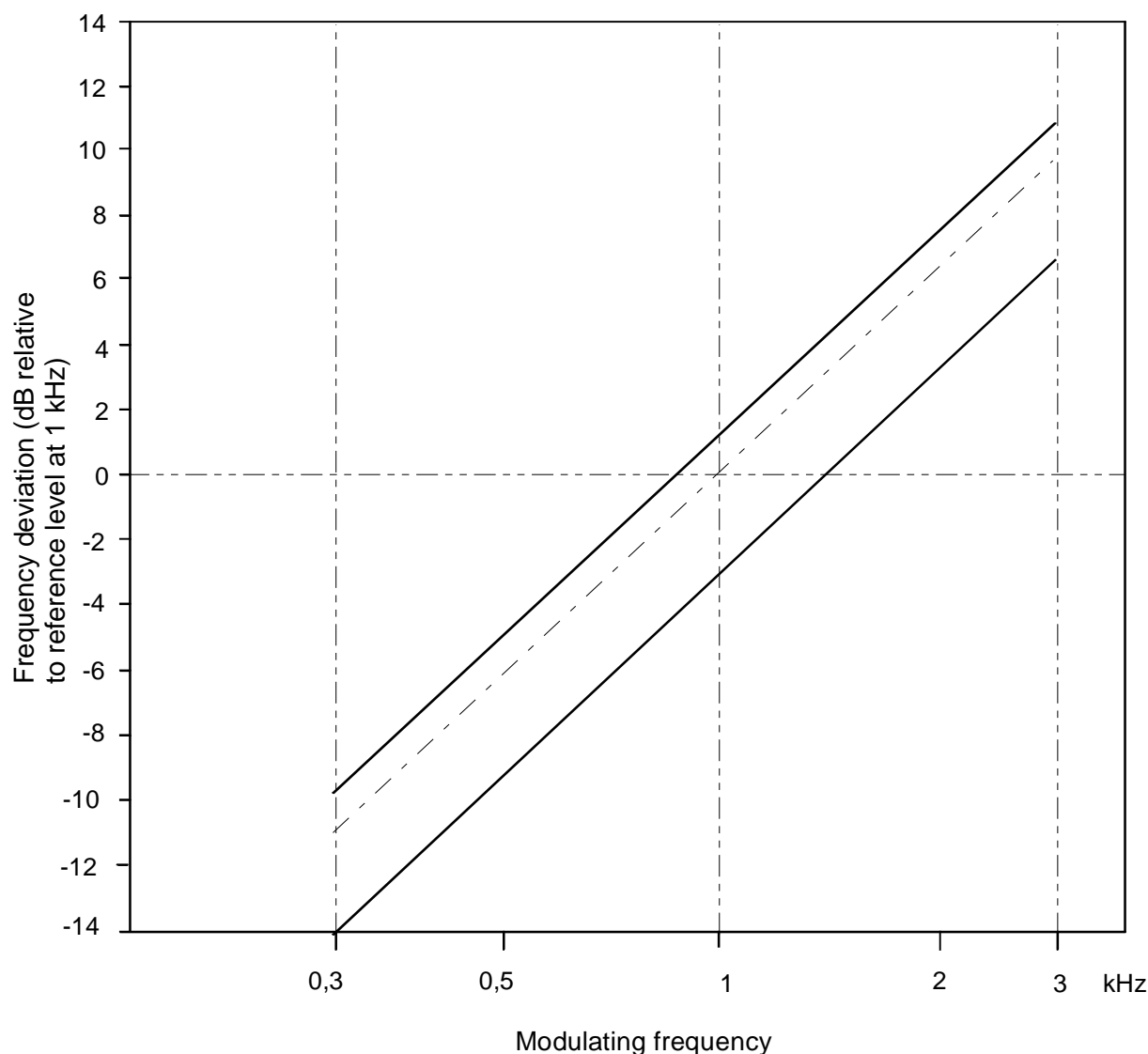

Figure 2: Audio frequency response

## 8.7 Audio frequency harmonic distortion of the emission

### 8.7.1 Definition

The harmonic distortion of the emission modulated by an audio frequency signal is defined as the ratio, expressed as a percentage, of the root mean square (rms) voltage of all the harmonic components of the fundamental frequency to the total rms voltage of the signal, measured after linear demodulation.

### 8.7.2 Method of measurement

The RF signal produced by the transmitter shall be applied via an appropriate coupling device to a linear demodulator with a de-emphasis network of 6 dB per octave.

The radio frequency signal shall be modulated successively at frequencies of 300 Hz and 1 000 Hz with a constant modulation index of 3 for 25 kHz channel equipment or a constant modulation index of 1,5 for 12,5 kHz channel equipment.

The distortion of the audio frequency signal shall be measured at the frequencies specified above.

The test shall be carried out on one channel only (see clause 6.6).

### 8.7.3 Limit

The harmonic distortion shall not exceed 10 %.

## 8.8 Adjacent channel power

### 8.8.1 Definition

The adjacent channel power is that part of the total power output of a transmitter under defined conditions of modulation, which falls within a specified passband centred on the nominal frequency of either of the adjacent channels. This power is the sum of the mean power produced by the modulation, hum and noise of the transmitter.

### 8.8.2 Method of measurement

The adjacent channel power shall be measured with a power measuring receiver which conforms to annex B (referred to in this clause and annex B as the "receiver") Recommendation ITU-R SM.332-4 [i.2]:

- a) The transmitter shall be activated under normal test conditions. If an output power switch is fitted it shall be placed in the maximum position.

The output of the transmitter shall be linked to the input of the "receiver" by a connecting device such that the impedance presented to the transmitter is 50  $\Omega$  and the level at the "receiver" input is appropriate.

- b) With the transmitter unmodulated, the tuning of the "receiver" shall be adjusted so that a maximum response is obtained. This is the 0 dB response point. The "receiver" attenuator setting and the reading of the meter shall be recorded.

The measurement may be made with the transmitter modulated with normal test modulation, in which case this fact shall be recorded with the test results.

- c) The tuning of the "receiver" shall be adjusted away from the carrier so that the "receiver" -6 dB response nearest to the transmitter carrier frequency is located at a displacement from the nominal carrier frequency of 17 kHz for 25 kHz channels or 8,25 kHz for 12,5 kHz channels.
- d) The transmitter shall be modulated with 1,25 kHz at a level which is 20 dB higher than that required to produce  $\pm 3$  kHz deviation for 25 kHz channels or  $\pm 1,5$  kHz deviation for 12,5 kHz channels.
- e) The "receiver" variable attenuator shall be adjusted to obtain the same meter reading as in step b) or a known relation to it.
- f) The ratio of adjacent channel power to carrier power is the difference between the attenuator settings in steps b) and e), corrected for any differences in the reading of the meter.
- g) The measurement shall be repeated with the "receiver" tuned to the other side of the carrier.

### 8.8.3 Limit

The adjacent channel power shall not exceed a value of:

- 25 kHz channel: 70 dB below the carrier power of the transmitter without any need to be below 0,2  $\mu$ W.
- 12,5 kHz channel: 60 dB below the carrier power of the transmitter without any need to be below 0,2  $\mu$ W.

## 8.9 Residual modulation of the transmitter

### 8.9.1 Definition

The residual modulation of the transmitter is the ratio, in dB, of the demodulated RF signal in the absence of wanted modulation, to the demodulated RF signal produced when the normal test modulation is applied.

## 8.9.2 Method of measurement

The normal test modulation defined in clause 6.4 shall be applied to the transmitter. The high frequency signal produced by the transmitter shall be applied, via an appropriate coupling device, to a linear demodulator with a de-emphasis network of 6 dB per octave. The time constant of this de-emphasis network shall be at least 750  $\mu$ s.

Precautions shall be taken to avoid the effects of emphasizing the low audio frequencies produced by internal noise.

The signal shall be measured at the demodulator output using a rms voltmeter.

The modulation shall then be switched off and the level of the residual audio frequency signal at the output shall be measured again.

The test shall be carried out on any one channel only (see clause 6.6).

## 8.9.3 Limit

The residual modulation shall not exceed -40 dB.

## 8.10 Transient frequency behaviour of the transmitter

### 8.10.1 Definition

The transient frequency behaviour of the transmitter is the variation in time of the transmitter frequency difference from the nominal frequency of the transmitter when the RF output power is switched on and off.

- $t_{on}$ : according to the method of measurement described in clause 8.10.2 the switch-on instant  $t_{on}$  of a transmitter is defined by the condition when the output power, measured at the antenna port, exceeds 0,1 % of the nominal power;
- $t_1$ : period of time starting at  $t_{on}$  and finishing according to table 4;
- $t_2$ : period of time starting at the end of  $t_1$  and finishing according to table 4;
- $t_{off}$ : switch-off instant defined by the condition when the nominal power falls below 0,1 % of the nominal power;
- $t_3$ : period of time that finishing at  $t_{off}$  and starting according to table 4.

**Table 4**

$t_1$ (ms)	5,0
$t_2$ (ms)	20,0
$t_3$ (ms)	5,0

### 8.10.2 Method of measurement

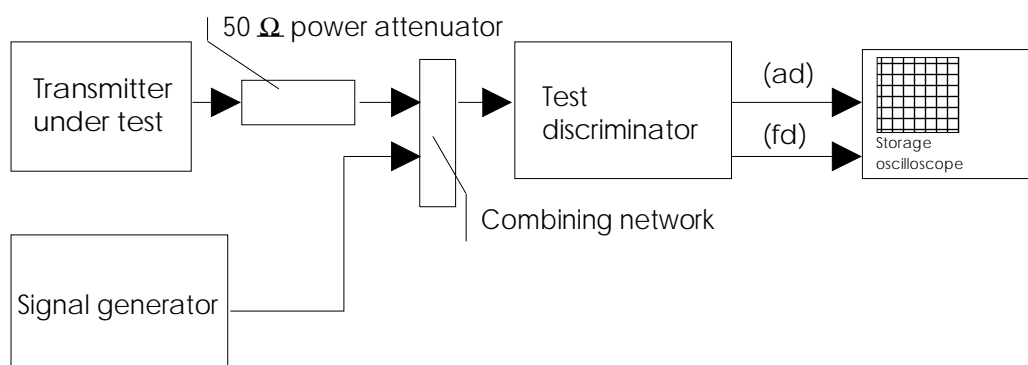

**Figure 3: Measurement arrangement**

Two signals shall be connected to the test discriminator via a combining network (see clause 6.2.2), figure 3.

The transmitter shall be connected to a 50  $\Omega$  power attenuator.

The output of the power attenuator shall be connected to the test discriminator via one input of the combining network.

A test signal generator shall be connected to the second input of the combining network.

The test signal shall be adjusted to the nominal frequency of the transmitter.

The test signal shall be modulated by a frequency of 1 kHz with a deviation equal to the channel spacing of the transmitter.

The test signal level shall be adjusted to correspond to 0,1 % of the power of the transmitter under test measured at the input of the test discriminator. This level shall be maintained throughout the measurement.

The amplitude difference (ad) and the frequency difference (fd) output of the test discriminator shall be connected to a storage oscilloscope.

The storage oscilloscope shall be set to display the channel corresponding to the (fd) input up to plus or minus one channel frequency difference, corresponding to the relevant channel separation, from the nominal frequency.

The storage oscilloscope shall be set to a sweep rate of 10 ms/division and set so that the triggering occurs at 1 division from the left edge of the display.

The display will show the 1 kHz test signal continuously.

The storage oscilloscope shall then be set to trigger on the channel corresponding to the amplitude difference (ad) input at a low input level, rising.

The transmitter shall then be switched on, without modulation, to produce the trigger pulse and a picture on the display.

The result of the change in the ratio of power between the test signal and the transmitter output will, due to the capture ratio of the test discriminator, produce two separate sides on the picture, one showing the 1 kHz test signal, the other the frequency difference of the transmitter versus time.

The moment when the 1 kHz test signal is completely suppressed is considered to provide  $t_{on}$ .

The periods of time  $t_1$  and  $t_2$  as defined in table 4 shall be used to define the appropriate template (see figure 4).

The transmitter shall remain switched on.

The storage oscilloscope shall be set to trigger on the channel corresponding to the amplitude difference (ad) input at a high input level, decaying and set so that the triggering occurs at 1 division from the right edge of the display.

The transmitter shall then be switched off.

The moment when the 1 kHz test signal starts to rise is considered to provide  $t_{off}$ .

The period of time  $t_3$  as defined in table 4 shall be used to define the appropriate template (see figure 4).

The test shall be carried out on one channel only (see clause 6.6).

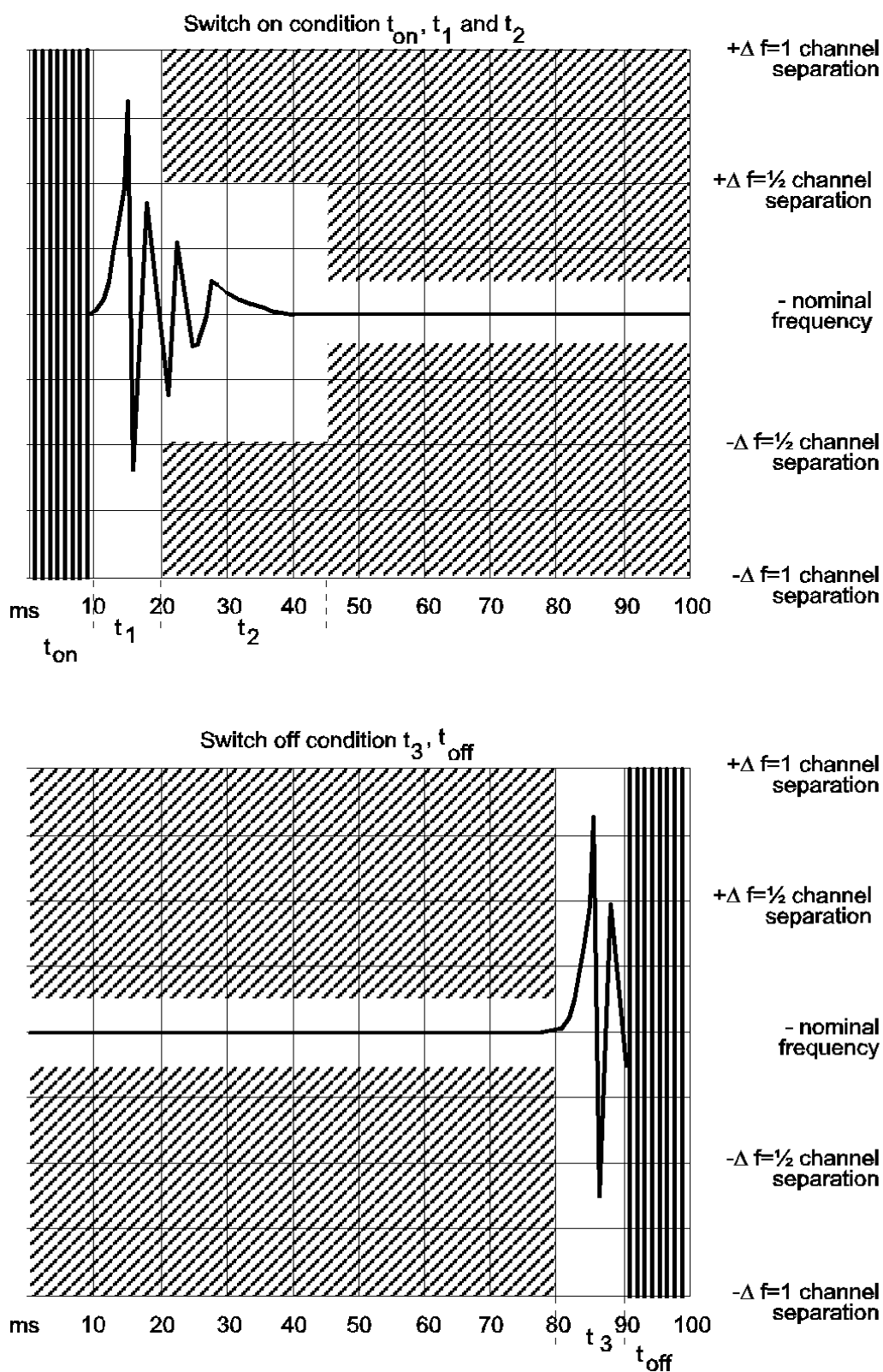

Figure 4

### 8.10.3 Limits

The results shall be recorded as frequency difference versus time.

During the periods of time  $t_1$  and  $t_2$  the frequency difference shall not exceed the values given in clause 8.10.1.

The frequency difference, after the end of  $t_2$ , shall be within the limit of the frequency error, see clause 8.1.



During the period of time  $t_3$  the frequency difference shall not exceed the values given in clause 8.10.1.

Before the start of  $t_3$  the frequency difference shall be within the limit of the frequency error, see clause 8.1.

## 8.11 Conducted spurious emissions conveyed to the antenna

### 8.11.1 Definition

Conducted spurious emissions are emissions on a frequency or frequencies which are outside the necessary bandwidth and the level of which may be reduced without affecting the corresponding transmission of information. Spurious emissions include harmonic emissions, parasitic emissions, intermodulation products and frequency conversion products, but exclude out of band emissions.

### 8.11.2 Method of measurement

Conducted spurious emissions shall be measured with the unmodulated transmitter connected to the artificial antenna (see clause 6.5).

The measurements shall be made over a range from 9 kHz to 2 GHz, excluding the channel on which the transmitter is operating and its adjacent channels.

The measurements for each spurious emission shall be made using a tuned radio measuring instrument or a spectrum analyser.

### 8.11.3 Limit

The power of any spurious emission on any discrete frequency shall not exceed 0,25  $\mu$ W.

## 8.12 Cabinet radiation and conducted spurious emissions other than those conveyed to the antenna

### 8.12.1 Definitions

Cabinet radiation consists of emissions at frequencies, other than those of the carrier and the sideband components resulting from the wanted modulation process, which are radiated by the equipment cabinet and structures.

Conducted spurious emissions other than those conveyed to the antenna are emissions at frequencies, other than those of the carrier and the sideband components resulting from the wanted modulation process, which are produced by conduction in the wiring and accessories used with the equipment.

### 8.12.2 Method of measurement

On a test site, selected from clause 5 of ETSI TS 103 052 [4], the equipment shall be placed at the specified height on a non-conducting support and in a position which is closest to normal use as declared by the manufacturer.

The transmitter antenna connector shall be connected to an artificial antenna, clause 6.5.

Integral antenna equipment shall be tested with the normal antenna fitted and the carrier frequency emission shall be filtered as described in the method of measurement. The test antenna shall be orientated for vertical polarization and the length of the test antenna shall be chosen to correspond to the instantaneous frequency of the measuring receiver, or a suitable broadband antenna may be used.

The output of the test antenna shall be connected to a measuring receiver.

For integral antenna equipment testing, a filter shall be inserted between the test antenna and the measuring receiver. For the measurement of spurious emissions below the second harmonic of the carrier frequency the filter used shall be a high Q (notch) filter centred on the transmitter carrier frequency and attenuating this signal by at least 30 dB. For the measurement of spurious emissions at and above the second harmonic of the carrier frequency the filter used shall be a high pass filter with a stop band rejection exceeding 40 dB and the cut off frequency of this high pass filter shall be approximately 1,5 times the transmitter carrier frequency.

The transmitter shall be switched on without modulation, and the measuring receiver shall be tuned over the frequency range 30 MHz to 2 GHz, except for the channel on which the transmitter is intended to operate and its adjacent channels.

At each frequency at which a spurious component is detected:

- a) the test antenna shall be raised and lowered through the specified range of heights until a maximum signal level is detected on the measuring receiver. (When a test site according to clause 5.2.1.2 of ETSI TS 103 052 [4] is used there is no need to vary the height of the antenna);
- b) the transmitter shall be rotated through 360° in the horizontal plane, until the maximum signal level is detected by the measuring receiver;
- c) the maximum signal level detected by the measuring receiver shall be noted;
- d) the transmitter shall be replaced by a substitution antenna as defined in clause 5.3.2 of ETSI TS 103 052 [4];
- e) the substitution antenna shall be orientated for vertical polarization and the length of the substitution antenna shall be adjusted to correspond to the frequency of the spurious component detected;
- f) the substitution antenna shall be connected to a calibrated signal generator;
- g) the frequency of the calibrated signal generator shall be set to the frequency of the spurious component detected;
- h) the input attenuator setting of the measuring receiver shall be adjusted in order to increase the sensitivity of the measuring receiver, if necessary;
- i) the test antenna shall be raised and lowered through the specified range of heights to ensure that the maximum signal is received. (When a test site according to clause 5.2.1.2 of ETSI TS 103 052 [4] is used there is no need to vary the height of the antenna);
- j) the input signal to the substitution antenna shall be adjusted to the level that produces a level detected by the measuring receiver that is equal to the level noted while the spurious component was measured, corrected for the change of input attenuator setting of the measuring receiver;
- k) the input level to the substitution antenna shall be recorded as power level, corrected for the change of input attenuator setting of the measuring receiver;
- l) the measurement shall also be taken with the test antenna and the substitution antenna orientated for horizontal polarization;
- m) the effective radiated power of the spurious component is the larger of the two power levels recorded for that spurious component at the input to the substitution antenna, corrected to compensate for the gain of the antenna if necessary;
- n) the measurements shall be repeated with the transmitter in stand-by mode.

### 8.12.3 Limits

With the transmitter in stand-by mode the cabinet radiation and spurious emissions shall not exceed 2 nW.

With the transmitter in operation the cabinet radiation and spurious emissions shall not exceed 0,25 µW.

---

## 9 Receiver

### 9.1 Harmonic distortion and rated audio frequency output power

#### 9.1.1 Definition

The harmonic distortion at the receiver output port is defined as the ratio, expressed as a percentage, of the total rms voltage of all the harmonic components of the modulation audio frequency to the total rms voltage of the signal delivered by the receiver.

The rated audio frequency output power is the value stated by the manufacturer to be the maximum power available at the output port, for which all the requirements of the present document are met.

#### 9.1.2 Methods of measurement

Test signals at levels of +60 dB $\mu$ V and +100 dB $\mu$ V, at a carrier frequency equal to the nominal frequency of the receiver and modulated by the normal test modulation (see clause 6.4) shall be applied in succession to the receiver antenna port under the conditions specified in clause 6.2.2.

For each measurement, the receiver's audio frequency volume control shall be set so as to obtain, in a resistive load which simulates the receiver's operating load, the rated audio frequency output power (see clause 9.1.1). The value of this load shall be stated by the manufacturer.

Under normal test conditions (see clause 5.3) the test signal shall be modulated successively at 300 Hz, 500 Hz and 1 kHz with a constant modulation index of 3 for 25 kHz channel equipment or a constant modulation index of 1,5 for 12,5 kHz channel equipment. The harmonic distortion and audio frequency output power shall be measured at all the frequencies specified above.

Under extreme test conditions (clauses 5.4.1 and 5.4.2 applied simultaneously), the tests shall be made at the receiver's nominal frequency and at the nominal frequency  $\pm 1,5$  kHz for 25 kHz channel equipment or  $\pm 0,75$  kHz for 12,5 kHz channel equipment. For these tests, the modulation frequency shall be 1 kHz and the frequency deviation shall be  $\pm 3$  kHz for 25 kHz channel equipment or  $\pm 1,5$  kHz for 12,5 kHz channel equipment.

The test shall be carried out on one channel only (see clause 6.6).

#### 9.1.3 Limits

The rated audio frequency output power shall be at least:

- 200 mW in a loudspeaker (except for repeater equipment);
- 1 mW in the handset earphone if provided.

The harmonic distortion shall not exceed 10 %.

### 9.2 Audio frequency response

#### 9.2.1 Definition

The audio frequency response is the variation in the receiver's audio frequency output level as a function of the modulating frequency of the radio frequency signal with constant deviation applied to its input.

#### 9.2.2 Method of measurement

A test signal of +60 dB $\mu$ V, at a carrier frequency equal to the nominal frequency of the receiver and modulated with normal test modulation (see clause 6.4), shall be applied to the receiver antenna port under the conditions specified in clause 6.2.2.

The receiver's audio frequency power control shall be set so as to produce a power level equal to 50 % of the rated output power (see clause 9.1). This setting shall remain unchanged during the test.

The frequency deviation shall then be reduced to 1 kHz for 25 kHz channel equipment or 500 Hz for 12,5 kHz channel equipment and the audio output is the reference point in figure 5 (1 kHz corresponds to 0 dB).

The frequency deviation shall remain constant while the modulation frequency is varied between 300 Hz and 3 kHz for 25 kHz channel equipment or 300 Hz and 2,55 kHz for 12,5 kHz channel equipment and the output level shall then be measured.

The measurement shall be repeated with a test signal at frequencies 1,5 kHz above and below the nominal frequency of the receiver for 25 kHz channel equipment or 750 Hz above and below the nominal frequency of the receiver for 12,5 kHz channel equipment.

The test shall be carried out on any one channel only (see clause 6.6).

### 9.2.3 Limits

The audio frequency response shall not deviate by more than +1 dB or -3 dB from a characteristic giving the output level as a function of the audio frequency, decreasing by 6 dB per octave and passing through the measured point at 1 kHz (see figure 5). For 12,5 kHz channels the upper frequency limit shall be 2,55 kHz.

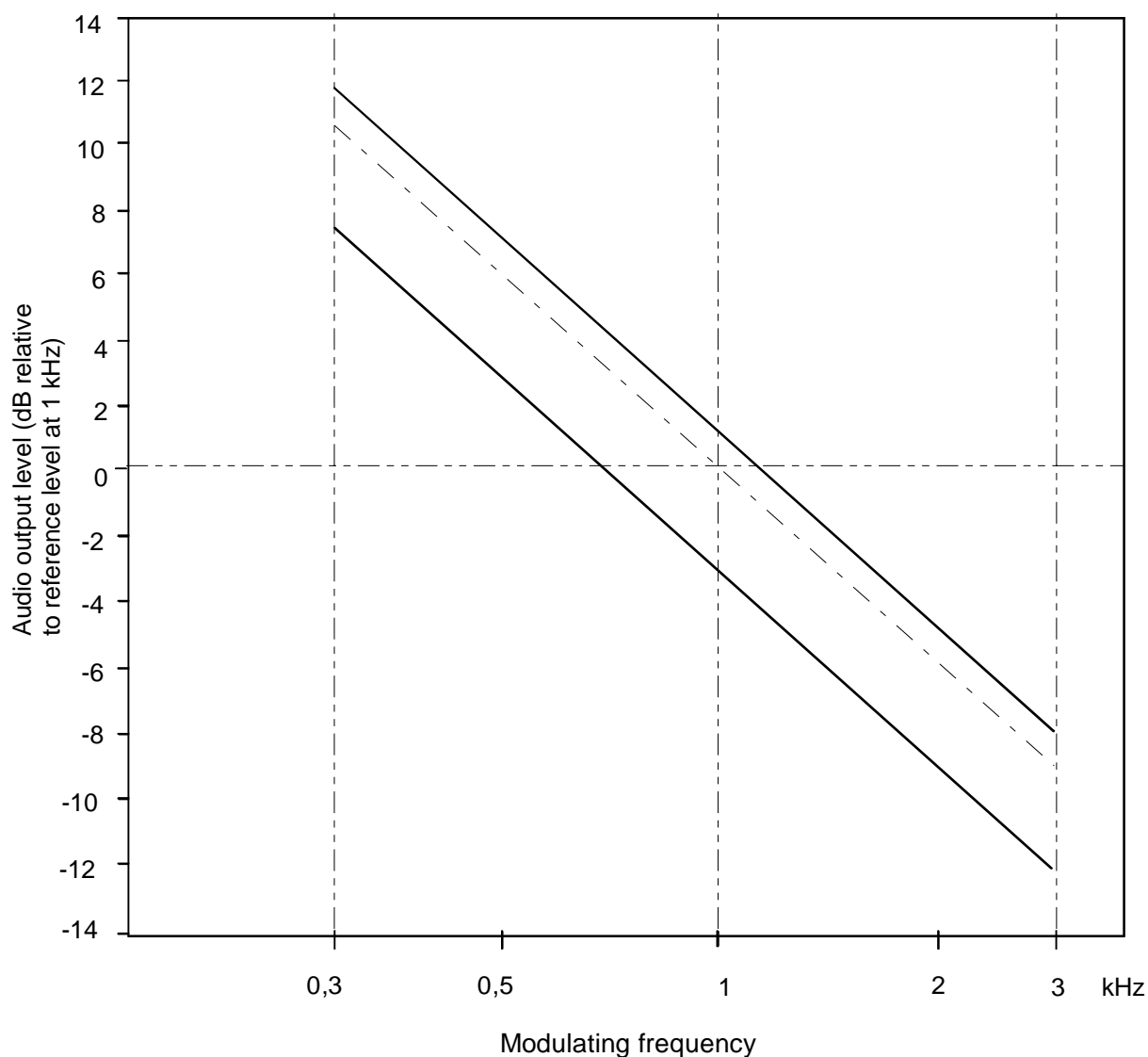

Figure 5: Audio frequency response

## 9.3 Maximum usable sensitivity

### 9.3.1 Definition

The maximum usable sensitivity of the receiver is the minimum level of the signal at the nominal frequency of the receiver which, when applied to the receiver antenna port with normal test modulation (see clause 6.4), will produce:

- in all cases, an audio frequency output power equal to 50 % of the rated output power (see clause 9.1); and
- a SINAD ratio of 20 dB, measured at the receiver output port through a psophometric telephone filtering network as described in Recommendation ITU-T O.41 [2].

### 9.3.2 Method of measurement

A test signal at a carrier frequency equal to the nominal frequency of the receiver, modulated by the normal test modulation (see clause 6.4) shall be applied to the receiver antenna port. An audio frequency load and a measuring instrument for measuring the SINAD ratio (through a psophometric network as specified in clause 9.3.1) shall be connected to the receiver output port.

The level of the test signal shall be adjusted until a SINAD ratio of 20 dB is obtained, using the psophometric network and with the receiver's audio frequency power control adjusted to produce 50 % of the rated output power. The level of the test signal at the antenna port is the value of the maximum usable sensitivity.

The measurements shall be made under normal test conditions (see clause 5.3) and under extreme test conditions (clauses 5.4.1 and 5.4.2 applied simultaneously).

A receiver output power variation of  $\pm 3$  dB relative to 50 % of the rated output power may be allowed for sensitivity measurements under extreme test conditions.

### 9.3.3 Limits

The maximum usable sensitivity shall not exceed +6 dB $\mu$ V under normal test conditions and +12 dB $\mu$ V under extreme test conditions.

## 9.4 Co-channel rejection

### 9.4.1 Definition

The co-channel rejection is a measure of the capability of the receiver to receive a wanted modulated signal without exceeding a given degradation due to the presence of an unwanted modulated signal, both signals being at the nominal frequency of the receiver.

### 9.4.2 Method of measurement

The two input signals shall be connected to the receiver antenna port via a combining network (see clause 6.2.2). The wanted signal shall have normal test modulation (see clause 6.4). The unwanted signal shall be modulated by 400 Hz with a deviation of 3 kHz. Both input signals shall be at the nominal frequency of the receiver under test. The measurement shall be repeated for displacements of the unwanted signal of  $\pm 3$  kHz.

For 12,5 kHz channels the frequency deviation and the displacement of the unwanted signal shall be  $\pm 1,5$  kHz.

The wanted input signal level shall be set to the value corresponding to the maximum usable sensitivity as measured in clause 9.3. The amplitude of the unwanted input signal shall then be adjusted until the SINAD ratio (psophometrically weighted) at the output port of the receiver is reduced to 14 dB.

The co-channel rejection ratio shall be expressed as the ratio in dB of the level of the unwanted signal to the level of the wanted signal at the receiver antenna port for which the specified reduction in SINAD ratio occurs.

The test shall be carried out on one channel only (see clause 6.6).

### 9.4.3 Limit

The co-channel rejection ratio, at any frequency of the unwanted signal within the specified range, shall be between:

- -10 dB and 0 dB for 25 kHz channels;
- -12 dB and 0 dB for 12,5 kHz channels.

## 9.5 Adjacent channel selectivity

### 9.5.1 Definition

The adjacent channel selectivity is a measure of the capability of the receiver to receive a wanted modulated signal without exceeding a given degradation due to the presence of an unwanted modulated signal which differs in frequency from the wanted signal by the nominal channel spacing.

### 9.5.2 Method of measurement

The two input signals shall be applied to the receiver input via a combining network (see clause 6.2.2). The wanted signal shall be at the nominal frequency of the receiver and shall have normal test modulation (see clause 6.4). The unwanted signal shall be modulated by 400 Hz with a deviation of  $\pm 3$  kHz for 25 kHz channels or  $\pm 1,5$  kHz for 12,5 kHz channels, and shall be at the frequency of the channel immediately above that of the wanted signal.

The wanted input signal level shall be set to the value corresponding to the maximum usable sensitivity as measured in clause 9.3. The amplitude of the unwanted input signal shall then be adjusted until the SINAD ratio at the receiver output port, psophometrically weighted, is reduced to 14 dB. The measurement shall be repeated with an unwanted signal at the frequency of the channel immediately below that of the wanted signal.

The adjacent channel selectivity shall be expressed as the lower value of the ratios in dB for the upper and lower adjacent channels of the level of the unwanted signal to the level of the wanted signal.

### 9.5.3 Limits

25 kHz channels: The adjacent channel selectivity shall be not less than 70 dB under normal test conditions and not less than 60 dB under extreme test conditions.

12,5 kHz channels: The adjacent channel selectivity shall be not less than 60 dB under normal test conditions and not less than 50 dB under extreme test conditions.

## 9.6 Spurious response rejection

### 9.6.1 Definition

The spurious response rejection is a measure of the capability of the receiver to discriminate between the wanted modulated signal at the nominal frequency and an unwanted signal at any other frequency at which a response is obtained.

### 9.6.2 Method of measurement

Two input signals shall be applied to the receiver antenna port via a combining network (see clause 6.2.2). The wanted signal shall be at the nominal frequency of the receiver and shall be modulated with normal test modulation (see clause 6.4).

The unwanted signal shall be modulated by 400 Hz with a deviation of 3 kHz for 25 kHz channel equipment or 1,5 kHz for 12,5 kHz channel equipment.

The wanted input signal level shall be set to the value corresponding to the maximum usable sensitivity as measured in clause 9.3. The amplitude of the unwanted input signal shall be adjusted to +86 dB $\mu$ V. The frequency shall then be stepped over the frequency range from 100 kHz to 2 000 MHz in steps not larger than 5 kHz.

At any frequency at which a response is obtained, the input level shall be adjusted until the SINAD ratio, psophometrically weighted, is reduced to 14 dB.

The spurious response rejection ratio shall be expressed as the ratio in dB between the unwanted signal and the wanted signal at the receiver antenna port when the specified reduction in the SINAD ratio is obtained.

The test shall be carried out on one channel only (see clause 6.6).

### 9.6.3 Limit

At any frequency separated from the nominal frequency of the receiver by more than the nominal channel spacing, the spurious response rejection ratio shall be not less than 70 dB.

## 9.7 Intermodulation response

### 9.7.1 Definition

The intermodulation response is a measure of the capability of a receiver to receive a wanted modulated signal without exceeding a given degradation due to the presence of two or more unwanted signals with a specific frequency relationship to the wanted signal frequency.

### 9.7.2 Method of measurement

Three signal generators, A, B and C shall be connected to the receiver antenna port via a combining network (see clause 6.2.2). The wanted signal, represented by signal generator A shall be at the nominal frequency of the receiver and shall have normal test modulation (see clause 6.4). The unwanted signal from signal generator B shall be unmodulated and adjusted to the frequency 50 kHz above the nominal frequency of the receiver. The second unwanted signal from signal generator C shall be modulated by 400 Hz with a deviation of 3 kHz for 25 kHz channel equipment or 1,5 kHz for 12,5 kHz channel equipment, and adjusted to a frequency 100 kHz above the nominal frequency of the receiver.

The wanted input signal shall be set to a value corresponding to the maximum usable sensitivity as measured in clause 9.3. The amplitude of the two unwanted signals shall be maintained equal and shall be adjusted until the SINAD ratio at the receiver output port, psophometrically weighted, is reduced to 14 dB. The frequency of signal generator B shall be adjusted to produce the maximum degradation of the SINAD ratio. The level of the two unwanted test signals shall be readjusted to restore the SINAD ratio of 14 dB. The intermodulation response ratio shall be expressed as the ratio in dB between the two unwanted signals and the wanted signal at the receiver antenna port, when the specified reduction in the SINAD ratio is obtained.

The measurement shall be repeated with the unwanted signal from signal generator (B) at a frequency 25 kHz above the wanted signal and with the unwanted signal from signal generator (C) at a frequency 50 kHz above the wanted signal.

The set measurements described above shall be repeated with the unwanted signals below the nominal frequency by the specified amounts.

### 9.7.3 Limit

The intermodulation response ratio shall be greater than 68 dB.

## 9.8 Blocking or desensitization

### 9.8.1 Definition

Blocking is a change (generally a reduction) in the wanted audio frequency output power of the receiver or a reduction of the SINAD ratio due to an unwanted signal on another frequency.

### 9.8.2 Method of measurement

Two input signals shall be applied to the receiver via a combining network (see clause 6.2). The modulated wanted signal shall be at the nominal frequency of the receiver and shall have normal test modulation (see clause 6.4). Initially the unwanted signal shall be switched off and the wanted signal set to the value corresponding to the measured maximum usable sensitivity (see clause 9.3).

The audio frequency output power of the wanted signal shall be adjusted, where possible, to 50 % of the rated audio frequency output power and in the case of stepped volume controls, to the first step that provides an audio frequency output power of at least 50 % of the rated audio frequency output power. The unwanted signal shall be un-modulated at frequencies of  $\pm 1$  MHz,  $\pm 2$  MHz,  $\pm 5$  MHz and  $\pm 10$  MHz relative to the nominal frequency of the receiver. The input level of the unwanted signal, at all frequencies in the specified ranges, shall be adjusted so that the unwanted signal causes:

- a reduction of 3 dB in the audio frequency output level of the wanted signal; or
- a reduction to 14 dB of the SINAD ratio (psophometrically weighted) at the receiver audio frequency output, whichever occurs first.

This level shall be noted.

### 9.8.3 Limit

The blocking level for any frequency within the specified ranges, shall be not less than 90 dB $\mu$ V, except at frequencies on which spurious responses are found (see clause 9.6).

## 9.9 Conducted spurious emissions conveyed to the antenna

### 9.9.1 Definition

Conducted spurious emissions are components at any frequency generated in the receiver and radiated by its antenna.

### 9.9.2 Method of measurement

Spurious radiations shall be measured as the power level of any discrete signal at the antenna port of the receiver. The receiver antenna port is connected to a spectrum analyser or selective voltmeter having an input impedance of 50  $\Omega$  and the receiver is switched on.

If the detecting device is not calibrated in terms of power input, the level of any detected components shall be determined by a substitution method using a signal generator.

The measurements shall extend over the frequency range of 9 kHz to 2 GHz.

### 9.9.3 Limit

The power of any spurious component between 9 kHz and 2 GHz shall not exceed 2 nW.

## 9.10 Radiated spurious emissions

### 9.10.1 Definition

Radiated spurious emissions from the receiver are components at any frequency radiated by the equipment cabinet and the structure.

### 9.10.2 Method of measurements

On a test site selected from clause 5 of ETSI TS 103 052 [4], the equipment shall be placed at the specified height on a non-conducting support and in a position which is closest to normal use as declared by the manufacturer.

Equipment with an antenna connector shall be connected to an artificial antenna, clause 6.5.

Integral antenna equipment shall be tested with the normal antenna fitted.

The test antenna shall be orientated for vertical polarization and the length of the test antenna shall be chosen to correspond to the instantaneous frequency of the measuring receiver, or a suitable broadband antenna may be used.

The output of the test antenna shall be connected to a measuring receiver.

The receiver shall be switched on without modulation, and measuring receiver shall be tuned over the frequency range 30 MHz to 2 GHz.



At each frequency at which a spurious component is detected:

- a) the test antenna shall be raised and lowered through the specified range of heights until a maximum signal level is detected on the measuring receiver. (When a test site according to clause 5.2.1.2 of ETSI TS 103 052 [4] is used there is no need to vary the height of the antenna);
- b) the receiver shall be rotated through 360° in the horizontal plane, until the maximum signal level is detected by the measuring receiver;
- c) the maximum signal level detected by the measuring receiver shall be noted;
- d) the receiver shall be replaced by a substitution antenna as defined in clause 5.3.2 of ETSI TS 103 052 [4];
- e) the substitution antenna shall be orientated for vertical polarization and the length of the substitution antenna shall be adjusted to correspond to the frequency of the spurious component detected;
- f) the substitution antenna shall be connected to a calibrated signal generator;
- g) the frequency of the calibrated signal generator shall be set to the frequency of the spurious component detected;
- h) the input attenuator setting of the measuring receiver shall be adjusted in order to increase the sensitivity of the measuring receiver, if necessary;
- i) the test antenna shall be raised and lowered through the specified range of heights to ensure that the maximum signal is received. (When a test site according to clause 5.2.1.2 of ETSI TS 103 052 [4] is used there is no need to vary the height of the antenna);
- j) the input signal to the substitution antenna shall be adjusted to the level that produces a level detected by the measuring receiver that is equal to the level noted while the spurious component was measured, corrected for the change of input attenuator setting of the measuring receiver;
- k) the input level to the substitution antenna shall be recorded as power level, corrected for the change of input attenuator setting of the measuring receiver;
- l) the measurement shall also be taken with the test antenna and the substitution antenna orientated for horizontal polarization;
- m) the effective radiated power of the spurious component is the larger of the two power levels recorded for that spurious component at the input to the substitution antenna, corrected to compensate for the gain of the antenna if necessary.

### 9.10.3 Limit

The power of any spurious radiation shall not exceed 2 nW at any frequency in the range between 30 MHz and 2 GHz.

---

## 10 Testing for compliance with technical requirements

### 10.1 Environmental conditions for testing

These shall be as described clause 6.

### 10.2 Interpretation of the measurement results

The interpretation of the results recorded in a test report for the measurements described in the present document shall be as follows:

- the measured value related to the corresponding limit will be used to decide whether an equipment meets the requirements of the present document;
- the value of the measurement uncertainty for the measurement of each parameter shall be included in the test report;

- the recorded value of the measurement uncertainty shall be, for each measurement, equal to or lower than the figures in table 5.

For the test methods, according to the present document, the measurement uncertainty figures shall be calculated and shall correspond to an expansion factor (coverage factor)  $k = 1,96$  or  $k = 2$  (which provide confidence levels of respectively 95 % and 95,45 % in the case where the distributions characterizing the actual measurement uncertainties are normal (Gaussian)). Principles for the calculation of measurement uncertainty are contained in ETSI TR 100 028 (parts 1 and 2) [i.4] and [i.5], in particular in annex D of the ETSI TR 100 028-2 [i.5].

Table 5 is based on such expansion factors.

**Table 5: Absolute measurement uncertainties: maximum values**

Parameter	Maximum uncertainty
RF frequency	$1 \times 10^{-7}$
RF power	0,75 dB
Maximum frequency deviation:	
- within 300 Hz to 6 kHz of modulation frequency	5 %
- within 6 kHz to 25 kHz of modulation frequency	3 dB
Deviation limitation	5 %
Adjacent channel power	5 dB
Audio output power	0,5 dB
Amplitude characteristics of receiver limiter	1,5 dB
Sensitivity at 20 dB SINAD	3 dB
Two-signal measurement	4 dB
Three-signal measurement	3 dB
Conducted spurious emission of transmitter	4 dB
Conducted emission of receiver	3 dB
Radiated emission of transmitter	6 dB
Radiated emission of receiver	6 dB
Transmitter transient time	20 %
Transmitter transient frequency	250 Hz

## Annex A (normative): Relationship between the present document and the essential requirements of Directive 2014/53/EU

The present document has been prepared in reply to the Commission's standardisation request Commission Implementing Decision C(2015) 5376 final of 04.08.2015 to provide a means of conforming to the essential requirements of Directive 2014/53/EU on the harmonisation of the laws of the Member States relating to the making available on the market of radio equipment.

Once the present document is cited in the Official Journal of the European Union under that Directive, compliance with the normative clauses of the present document given in table A.1 confers, within the limits of the scope of the present document, a presumption of conformity with the corresponding essential requirements of that Directive, and associated EFTA regulations.

**Table A.1: Relationship between the present document and the essential requirements of Directive 2014/53/EU**

<b>Harmonised Standard ETSI EN 300 720</b>				
The following requirements are relevant to the presumption of conformity under the article 3.2 of Directive 2014/53/EU [i.3]				
<b>Requirement</b>			<b>Requirement Conditionality</b>	
<b>No</b>	<b>Description</b>	<b>Reference: Clause No</b>	<b>U/C</b>	<b>Condition</b>
1	Transmitter frequency error	8.1	U	
2	Transmitter maximum effective radiated power	8.2	U	
3	Transmitter frequency deviation	8.3.2	U	
4	Frequency deviation at modulation frequencies above 3 kHz	8.3.3	U	
5	Transmitter adjacent channel power	8.8	U	
6	Transient frequency behaviour of the transmitter	8.10	U	
7	Transmitter conducted spurious emissions conveyed to the antenna	8.11	U	
8	Transmitter cabinet radiation and conducted spurious emissions other than those conveyed to the antenna	8.12	U	
9	Receiver maximum usable sensitivity	9.3	U	
10	Receiver co-channel rejection	9.4	U	
11	Receiver adjacent channel selectivity	9.5	U	
12	Receiver spurious response rejection	9.6	U	
13	Receiver intermodulation response	9.7	U	
14	Receiver blocking or desensitization	9.8	U	
15	Receiver conducted spurious emissions conveyed to the antenna	9.9	U	
16	Receiver radiated spurious emissions	9.10	U	

### Key to columns:

#### Requirement:

**No** A unique identifier for one row of the table which may be used to identify a requirement.

**Description** A textual reference to the requirement.

**Clause Number** Identification of clause(s) defining the requirement in the present document unless another document is referenced explicitly.

#### Requirement Conditionality:

**U/C** Indicates whether the requirement shall be unconditionally applicable (U) or is conditional upon the manufacturers claimed functionality of the equipment (C).

**Condition** Explains the conditions when the requirement shall or shall not be applicable for a requirement which is classified "conditional".

Presumption of conformity stays valid only as long as a reference to the present document is maintained in the list published in the Official Journal of the European Union. Users of the present document should consult frequently the latest list published in the Official Journal of the European Union.

Other Union legislation may be applicable to the product(s) falling within the scope of the present document.

## Annex B (normative): Measuring receiver for adjacent channel power measurement

### B.1 Power measuring receiver specification

#### B.1.0 General

The power measuring receiver is used for the measurement of the transmitter adjacent channel power. It consists of a mixer and oscillator, an IF filter, an amplifier, a variable attenuator and a level indicator as shown below (figure B.1).

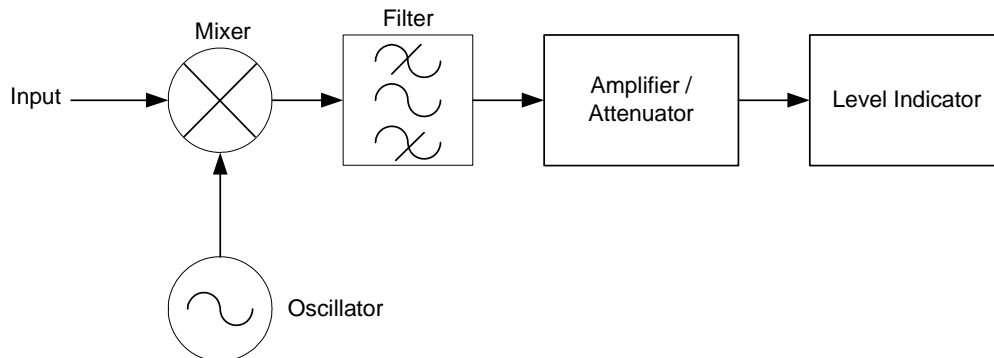
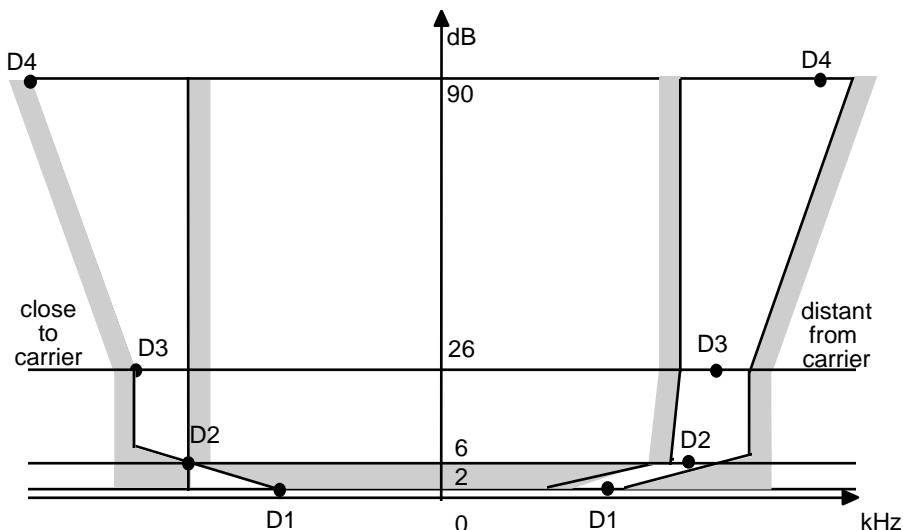

**Figure B.1: Power measuring receiver**

Instead of the Variable attenuator with the rms value indicator it is also possible to use a rms voltmeter calibrated in dB. The technical characteristics of the power measuring receiver are given in clauses B.1.1 to B.1.4.

#### B.1.1 IF filter

The IF filter shall be within the limits of the following selectivity characteristics.



**Figure B.2: IF filter characteristics**

The selectivity characteristics shall keep the frequency separations shown in table B.1 from the nominal centre frequency of the adjacent channel.

**Table B.1: Selectivity characteristic**

Channel separation (kHz)	Frequency separation of filter curve from nominal centre frequency of adjacent channel (kHz)			
	D1	D2	D3	D4
12,5	3	4,25	5,5	9,5
25	5	8,0	9,25	13,25

The attenuation points shall not exceed following tolerances shown in table B.2.

**Table B.2: Tolerance of attenuation points close to carrier**

Channel separation (kHz)	Tolerance range (kHz)			
	D1	D2	D3	D4
12,5	+1,35	±0,1	-1,35	-5,35
25	+3,1	±0,1	-1,35	-5,35

**Table B.3: Tolerance of attenuation points distant from the carrier**

Channel separation (kHz)	Tolerance range (kHz)			
	D1	D2	D3	D4
12,5	±2,0	±2,0	±2,0	+2,0 -6,0
25	±3,5	±3,5	±3,5	+3,5 -7,5

The minimum attenuation of the filter outside the 90 dB attenuation points shall be equal to or greater than 90 dB.

## B.1.2 Attenuation indicator

The attenuation indicator shall have a minimum range of 80 dB and a reading accuracy of 1 dB. With a view to future regulations an attenuation of 90 dB or more is recommended.

## B.1.3 rms value indicator

The instrument shall accurately indicate non-sinusoidal signals in ratio of up to 10:1 between peak value and rms value.

## B.1.4 Oscillator and amplifier

The oscillator and the amplifier shall be designed in such a way that the measurement of the adjacent channel power of a low-noise unmodulated transmitter, whose self-noise has a negligible influence on the measurement result, yields a measured value of less than -90 dB.

---

## History

<b>Document history</b>		
Edition 1	March 1997	Publication as ETSI ETS 300 720
V1.1.1	August 2000	Publication as ETSI EN 300 720 part 2
V1.2.1	August 2000	Publication as ETSI EN 300 720 part 1
V1.3.2	October 2007	Publication as ETSI EN 300 720 part 1
V1.2.1	November 2007	Publication as ETSI EN 300 720 part 2
V2.1.0	December 2015	EN Approval Procedure AP 20160310: 2015-12-11 to 2016-03-10