

ETSI EN 300 689 V1.2.1 (2001-07)

European Standard (Telecommunications series)

**Access and Terminals (AT);
34 Mbit/s digital leased lines (D34U and D34S);
Terminal equipment interface**



Reference

REN/AT-020009

Keywordsaccess, digital, interface, leased line, ONP,
terminal**ETSI**

650 Route des Lucioles
F-06921 Sophia Antipolis Cedex - FRANCE

Tel.: +33 4 92 94 42 00 Fax: +33 4 93 65 47 16

Siret N° 348 623 562 00017 - NAF 742 C
Association à but non lucratif enregistrée à la
Sous-Préfecture de Grasse (06) N° 7803/88

Important notice

Individual copies of the present document can be downloaded from:

<http://www.etsi.org>

The present document may be made available in more than one electronic version or in print. In any case of existing or perceived difference in contents between such versions, the reference version is the Portable Document Format (PDF). In case of dispute, the reference shall be the printing on ETSI printers of the PDF version kept on a specific network drive within ETSI Secretariat.

Users of the present document should be aware that the document may be subject to revision or change of status. Information on the current status of this and other ETSI documents is available at <http://www.etsi.org/tb/status/>

If you find errors in the present document, send your comment to:
editor@etsi.fr

Copyright Notification

No part may be reproduced except as authorized by written permission.
The copyright and the foregoing restriction extend to reproduction in all media.

© European Telecommunications Standards Institute 2001.
All rights reserved.

Contents

Intellectual Property Rights	5
Foreword	5
Introduction	6
1 Scope	7
2 References	7
3 Definitions and abbreviations	8
3.1 Definitions	8
3.2 Abbreviations	8
4 Requirements	9
4.1 Mechanical characteristics	9
4.1.1 Sockets	10
4.1.2 Plugs	10
4.2 Electrical characteristics	10
4.2.1 Output port	10
4.2.1.1 Signal coding	10
4.2.1.2 Waveform shape	10
4.2.1.3 Output timing	11
4.2.1.4 Output return loss	12
4.2.1.5 Output jitter	12
4.2.1.6 Output frame structure	12
4.2.2 Input port	13
4.2.2.1 Signal coding	13
4.2.2.2 Input return loss	13
4.2.2.3 Input loss tolerance	13
4.2.2.4 Immunity against reflections	13
4.2.2.5 Input jitter tolerance	13
4.2.2.6 Input clock tolerance	14
4.2.2.7 Input frame structure	14
4.2.2.8 Frame alignment procedure	14
4.3 Safety	15
4.4 Overvoltage	15
4.5 ElectroMagnetic Compatibility (EMC)	15
Annex A (normative): Test methods	16
A.1 General	16
A.1.1 Additional information to support the test	16
A.1.2 Equipment connection	16
A.2 Test methods	17
A.2.1 Signal coding at the output port	17
A.2.2 Waveform shape at the output port	17
A.2.3 Output timing	18
A.2.4 Input signal coding, loss tolerance and immunity against reflections	19
A.2.5 Input return loss	20
A.2.6 Output return loss	21
A.2.7 Input and output jitter	22
A.2.8 Frame structure	23
A.2.9 Frame alignment procedure	24
Annex B (normative): Definition of HDB3 code	26
B.1 General	26
B.2 Definition	26

Annex C (normative):	Definition of frame structure	27
C.1	Frame structure at 34 368 kbit/s	27
C.1.1	Trail access point identifier format.....	28
C.1.1.1	CRC-7 calculation - multiplication and division process	29
C.1.1.2	CRC-7 calculation - encoding procedure	29
C.1.1.3	CRC-7 calculation - decoding procedure	29
Annex D (normative):	Requirements Table (RT)	30
Annex E (informative):	Bibliography	31
History	32

Intellectual Property Rights

IPRs essential or potentially essential to the present document may have been declared to ETSI. The information pertaining to these essential IPRs, if any, is publicly available for **ETSI members and non-members**, and can be found in ETSI SR 000 314: "*Intellectual Property Rights (IPRs); Essential, or potentially Essential, IPRs notified to ETSI in respect of ETSI standards*", which is available from the ETSI Secretariat. Latest updates are available on the ETSI Web server (<http://www.etsi.org/ipr>).

Pursuant to the ETSI IPR Policy, no investigation, including IPR searches, has been carried out by ETSI. No guarantee can be given as to the existence of other IPRs not referenced in ETSI SR 000 314 (or the updates on the ETSI Web server) which are, or may be, or may become, essential to the present document.

Foreword

This European Standard (Telecommunications series) has been produced by ETSI Technical Committee Access and Terminals (AT).

The present document resulted from a mandate from the Commission of the European Community (CEC) to provide standards for the support of the Directive on Open Network Provision (ONP) of leased lines (92/44/EEC).

There are two other standards directly related to the present document:

- EN 300 686: "Access and Terminals (AT); 34 Mbit/s and 140 Mbit/s digital leased lines (D34U, D34S, D140U, D140S); Network interface presentation";
- EN 300 687: "Access and Terminals (AT); 34 Mbit/s digital leased lines (D34U and D34S); Connection characteristics".

The present document is based on information from ITU-T Recommendations and ETSI publications and the relevant documents are quoted where appropriate.

National transposition dates	
Date of adoption of this EN:	29 June 2001
Date of latest announcement of this EN (doa):	30 September 2001
Date of latest publication of new National Standard or endorsement of this EN (dop/e):	31 March 2002
Date of withdrawal of any conflicting National Standard (dow):	31 March 2002

Introduction

The Council Directive on the application of ONP to leased lines (92/44/EEC) concerns the harmonization of conditions for open and efficient access to, and use of, the leased lines provided over public telecommunications networks, and the availability throughout the European Union of a minimum set of leased lines with harmonized technical characteristics.

The 34 Mbit/s unstructured and structured leased lines are not part of the minimum set of leased lines under the leased line Directive, however these standards are being written with the intention that where 34 Mbit/s leased lines are offered, they will be in accordance with these harmonized standards.

Two categories (voluntary and regulatory) of standard were used for the interfaces of terminal equipment designed for connection to the ONP leased lines. Technical Basis for Regulations (TBRs) gave the earlier essential requirements under the Directive 91/263/EEC (see annex E), later replaced by 98/13/EC (see annex E), for attachment to the leased lines, whereas other voluntary standards (ETSS or ENs) gave the full technical specifications for these interfaces. The present document, which is based on an earlier ETS, belongs to the second category.

The requirements of TBR 24 (see annex E) are a subset of the present document.

The present version of the present document has been produced to introduce some necessary changes.

ETS 300 166 (see annex E) and ITU-T Recommendation G.703 [4] were used as the basis for the terminal equipment interface aspects of the present document.

1 Scope

The present document specifies the mechanical and electrical characteristics (except safety, overvoltage and EMC aspects), the necessary functional characteristics and the corresponding conformance tests for a terminal equipment interface for:

- connection to the network termination points of 34 368 kbit/s digital unstructured leased lines (D34U); and
- connection to the network termination points of 34 368 kbit/s digital structured leased lines (D34S) which support an unstructured 33 920 kbit/s information transfer rate.

These leased lines are defined in EN 300 686 [7] and EN 300 687 [8].

The present document is written only to ensure that the interface of the terminal equipment is compatible with the 34 Mbit/s digital unstructured or structured leased line. The present document is applicable to all interfaces designed for connection to the leased line, however in the cases of apparatus that carries a particular service, of complex apparatus and of apparatus in private networks, other requirements may apply in addition to the present document.

Customer premises wiring and installation between the terminal equipment and the Network Termination Point (NTP) are outside the scope of the present document.

2 References

The following documents contain provisions which, through reference in this text, constitute provisions of the present document.

- References are either specific (identified by date of publication, edition number, version number, etc.) or non-specific.
- For a specific reference, subsequent revisions do not apply.
- For a non-specific reference, the latest version applies.

- [1] IEC 60169-8 (1978): "Radio frequency connectors; Part 8: R.F coaxial connectors with inner diameters of outer conductor 6,5 mm (0,256 in) with bayonet lock - Characteristic impedance 50 ohms (Type BNC)".
- [2] IEC 60169-13 (1976): "Radio frequency connectors; Part 13: R.F. coaxial connectors with inner diameter of outer conductor 5,6 mm (0,22 in) - Characteristic impedance 75 ohms (Type 1,6/5,6) - Characteristic impedance 50 ohms (Type 1,8/5,6) with similar mating dimensions".
- [3] ISO/IEC 10173 (1998): "Information technology - Telecommunications and information exchange between systems - Interface connector and contact assignments for ISDN primary rate access connector located at reference points S and T".
- [4] ITU-T Recommendation G.703 (1998): "Physical/electrical characteristics of hierarchical digital interfaces".
- [5] ITU-T Recommendation O.151 (1992): "Error performance measuring equipment operating at the primary rate and above".
- [6] ITU-T Recommendation O.171 (1997): "Timing jitter and wander measuring equipment for digital systems which are based on the plesiochronous digital hierarchy (PDH)".
- [7] ETSI EN 300 686: "Access and Terminals (AT); 34 Mbit/s and 140 Mbit/s digital leased lines (D34U, D34S, D140U, D140S); Network interface presentation".
- [8] ETSI EN 300 687: "Access and Terminals (AT); 34 Mbit/s digital leased lines (D34U and D34S); Connection characteristics".

3 Definitions and abbreviations

3.1 Definitions

For the purposes of the present document, the following terms and definitions apply:

frame: repetitive set of consecutive bits in which the position of each bit can be identified by reference to a frame alignment signal

frame alignment signal: distinctive signal inserted in every frame always occupying the same relative position within the frame and used to establish and maintain frame alignment

leased lines: telecommunications facilities provided by a public telecommunications network that provide defined transmission characteristics between network termination points and that do not include switching functions that the user can control, (e.g. on-demand switching)

Network Termination Point (NTP): all physical connections and their technical access specifications which form part of the public telecommunications network and are necessary for access to and efficient communication through that public network

PRBS(2²³-1): Pseudo Random Bit Sequence (PRBS) (as defined in clause 2.2 of ITU-T Recommendation O.151)

terminal equipment: equipment intended to be connected to the public telecommunications network, i.e.:

- to be connected directly to the termination of a public telecommunication network; or
- to interwork with a public telecommunications network being connected directly or indirectly to the termination of a public telecommunications network;

in order to send, process, or receive information

3.2 Abbreviations

For the purposes of the present document, the following abbreviations apply:

AIS	Alarm indication Signal
AMI	Alternate Mark Inversion
ASCII	American Standard Code for Information Interchange
ATM	Asynchronous Transfer Mode
BIP-8	Bit Interleaved Parity (8 bit)
BNC	Bayonet Nut Connector
CRC-7	Cyclic Redundancy Check (7 bit)
dc	direct current
D34S	34 Mbit/s digital structured leased line
D34U	34 Mbit/s digital unstructured leased line
EM	Error Monitoring
EMC	ElectroMagnetic Compatibility
FA1	Frame Alignment byte 1
FA2	Frame Alignment byte 2
FAS	Frame Alignment Signal
GC	General purpose Communications channel
HDB3	High Density Bipolar code 3
LOF	Loss Of Frame
LOS	Loss Of Signal
LSB	Least Significant Bit
MA	Maintenance and Adaptation
MSB	Most Significant Bit
NR	Network operator byte
NTP	Network Termination Point
ONP	Open Network Provision
ppm	parts per million

PRBS	Pseudo Random Bit Sequence
RDI	Remote Defect Indication
REI	Remote Error Indication
RT	Requirements Table
RX	RX is a signal input (at either the terminal equipment or the test equipment, see figure 1)
SDH	Synchronous Digital Hierarchy
TM	Timing Marker
TU	Tributary Unit
TR	TRail trace
TTI	Trail Trace Identifier
TX	TX is a signal output (at either the terminal equipment or the test equipment, see figure 1)
UI	Unit Interval

4 Requirements

The D34U 34 368 kbit/s unstructured leased line provides a bi-directional point-to-point digital leased line for the support of an unstructured 34 368 kbit/s information transfer rate. Any structuring of the data is the responsibility of the user.

The D34S 34 368 kbit/s structured leased line provides a bi-directional point-to-point digital leased line for the support of an unstructured 33 920 kbit/s information transfer rate. Any structuring of the data within the transparent 33 920 kbit/s part of the frame is the responsibility of the user.

For both D34U and D34S the provision of timing is the responsibility of the user; however, in certain installations the leased line provider may be able to offer a leased line that is synchronized to the network.

4.1 Mechanical characteristics

The terminal equipment shall provide at least one of the methods of connection given in clauses 4.1.1 and 4.1.2.

NOTE 1: When connecting the terminal equipment to the NTP, any difference in ground potential between the two equipments may produce a voltage across the signal ground connection and may cause damage. See EN 50310 (see annex E) for details of earthing requirements within the customer's premises.

NOTE 2: The transmit pair is the output from the terminal equipment interface. The receive pair is the input to the terminal equipment interface, as shown in figure 1. Where the terms "output" and "input" are used without qualification in the present document, they refer to the terminal equipment interface.

NOTE 3: Normal practice is for the outer conductors of the input and output connectors to be connected via a dc path to the signal ground and thence to ground. This connection is to reduce EMC emissions. If there is a difference in ground potential between the terminal equipment and the NTP, this arrangement may result in high currents in the outer conductors and cause damage.

To prevent this problem, dc isolation may be introduced between the terminal equipment and the NTP, for example by introducing dc isolation between the outer conductor and the signal ground in the terminal equipment. Careful attention should be given to the requirements of standards on installation earthing practice.

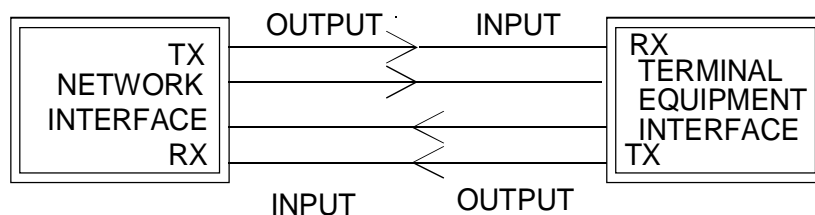

Figure 1

4.1.1 Sockets

Requirement: The terminal equipment interface shall provide two coaxial 75 Ω sockets, one each for transmit and receive; these sockets being either:

- a) 75 Ω sockets (type 1,6/5,6) complying with IEC 60169-13 [2]; or
- b) 75 Ω BNC sockets complying with the general requirements of IEC 60169-8 [1] with the mating dimensions specified in annex B of ISO/IEC 10173 [3].

The outer conductor of the coaxial pair shall be connected to signal ground both at the input port and at the output port.

Test: There shall be a visual inspection that the sockets are of the correct type.

4.1.2 Plugs

Requirement: The terminal equipment interface shall provide two coaxial 75 Ω plugs at the end of a cord (or cords), one each for transmit and receive; these plugs being either:

- a) 75 Ω plugs (type 1,6/5,6) complying with IEC 60169-13 [2]; or
- b) 75 Ω BNC plugs complying with the general requirements of IEC 60169-8 [1] with the mating dimensions specified in annex B of ISO/IEC 10173 [3].

The outer conductor of the coaxial pair shall be connected to signal ground both at the input port and at the output port.

NOTE: There is no requirement on the method of connection of the cord (or cords) to the terminal equipment.

Test: There shall be a visual inspection that the plugs are of the correct type.

4.2 Electrical characteristics

4.2.1 Output port

4.2.1.1 Signal coding

Requirement: The signal transmitted at the output port shall comply with the High Density Bipolar code 3 (HDB3) encoding rules (see annex B).

Test: The test shall be conducted according to clause A.2.1.

4.2.1.2 Waveform shape

Requirement: The pulse at the output port shall comply with the requirements given in table 1 and figure 2; based on ITU-T Recommendation G.703 [4].

Table 1: Waveform shape at output port

Pulse shape (nominally rectangular)	All marks of a valid signal shall conform with the mask (see figure 2). The value V corresponds to the nominal peak voltage of a mark.
Test load impedance	75 Ω non-reactive
Nominal peak voltage V of a mark	1,0 V
Peak voltage of a space	0 \pm 0,1 V
Nominal pulse width	14,55 ns
Ratio of the amplitudes of positive and negative pulses at the centre of the pulse interval	0,95 to 1,05
Ratio of the widths of positive and negative pulses at the nominal half amplitude	0,95 to 1,05

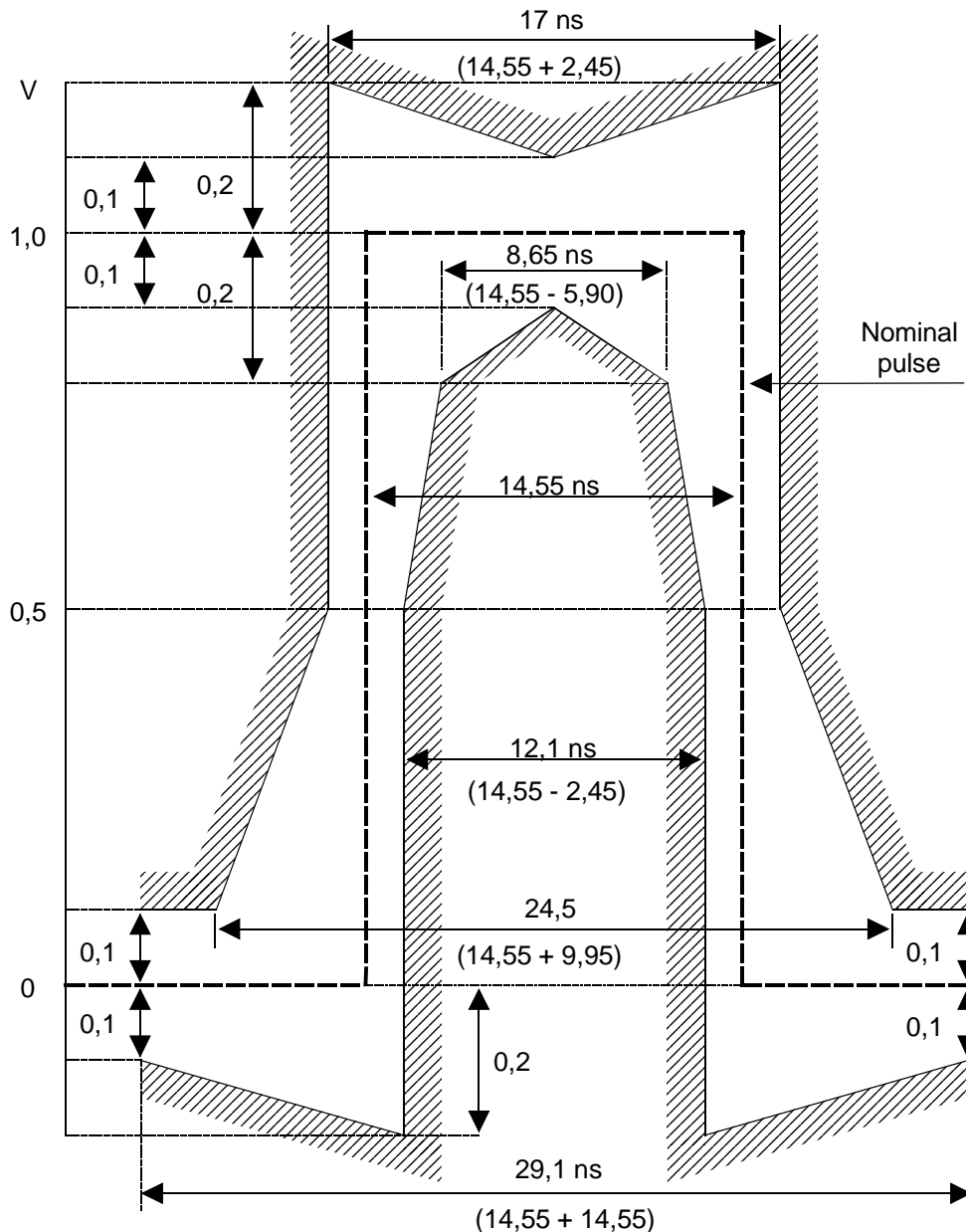

Figure 2: Pulse mask for 34 Mbit/s pulse

Test: The test shall be conducted according to clause A.2.2.

4.2.1.3 Output timing

The terminal equipment may derive its timing from:

- an internal source (e.g. an internal clock);
- an external reference signal input;
- the received signal at the input port.

Requirement: For each of the timing arrangements intended for use, the bit rate at the output port shall be within the limits of 34 368 kbit/s \pm 20 parts per million (ppm), when any relevant external signal, including the received signal at the input port, is within its stated tolerance.

NOTE: The tolerance of \pm 20 ppm relates to the transmission capability of the leased line. Tighter limits may be needed to ensure satisfactory end-to-end interworking with the distant terminal equipment.

Test: The test shall be conducted according to clause A.2.3.

4.2.1.4 Output return loss

Requirement: The output return loss at the terminal equipment interface, with respect to 75 Ω , shall be greater than or equal to the values given in table 2, which is taken from annex 3 of ETS 300 166 (see annex E).

Table 2: Output port minimum return loss

Frequency range	Return loss
860 kHz to 1 720 kHz	6 dB
1 720 kHz to 51 550 kHz	8 dB

Test: The test shall be conducted according to clause A.2.6.

4.2.1.5 Output jitter

Requirement: The peak-to-peak output jitter shall not exceed the limits of table 3 when measured with a bandpass filter with linear cut-off with the defined cut-off frequencies. At frequencies below the lower 3 dB point, the attenuation of the high pass filter shall rise with a value greater than, or equal to, 20 dB per decade. At frequencies above the upper 3 dB point, the attenuation of the low pass filtration shall rise with a value greater than, or equal to, 60 dB per decade.

For the purpose of testing, any signal input from which the output timing is derived shall be provided with the maximum tolerable input jitter, and with the maximum tolerable input frequency deviation, as specified by the manufacturer.

Where the output timing of the terminal equipment is taken from the leased line, the input to the terminal equipment shall be provided with components of sinusoidal jitter at points on the curve of figure 3 and table 5.

Table 3: Maximum output jitter

Measurement filter bandwidth		Output jitter
Lower cut-off (high pass)	Upper cut-off (low pass)	Unit Interval (UI) peak-to-peak (maximum)
100 Hz	800 kHz	0,4
10 kHz	800 kHz	0,15
NOTE: These values are chosen to allow for jitter build-up in user networks and may be different from ITU-T Recommendations.		

Test: The test shall be conducted according to clause A.2.7.

4.2.1.6 Output frame structure

The requirement of this clause applies to terminal equipment for connection to the D34S leased line. For terminal equipments for connection to the D34U leased line, there is no requirement on the structure of the output bit stream.

Requirement: For terminal equipments for connection to the D34S leased line, the bit stream transmitted at the output of the terminal equipment shall be structured as defined in annex C.

Bit 1 of byte Maintenance and Adaptation (MA), a Remote Defect Indication (RDI), shall be set to "1" within 250 μ s of the detection of loss of received frame alignment (see clause 4.2.2.8), and set to "0" within 250 μ s on gaining frame alignment.

Test: The test shall be conducted according to clause A.2.8 and A.2.9.

4.2.2 Input port

4.2.2.1 Signal coding

Requirement: The input port shall decode without error HDB3 encoded signals in accordance with HDB3 encoding rules (see annex B).

Test: The test shall be conducted according to clause A.2.4.

4.2.2.2 Input return loss

Requirement: The input return loss with respect to 75 Ω at the interface shall be greater than or equal to the values given in table 4, which is taken from clause 11.3 of ITU-T Recommendation G.703 [4].

Table 4: Input port minimum return loss

Frequency range	Return loss
860 kHz to 1 720 kHz	12 dB
1 720 kHz to 34 368 kHz	18 dB
34 368 kHz to 51 550 kHz	14 dB

Test: The test shall be conducted according to clause A.2.5.

4.2.2.3 Input loss tolerance

Requirement: The input port shall decode without errors a 34 368 kbit/s signal as defined in clauses 4.2.1.1 and 4.2.1.2 above but modified by a cable or artificial cable with the following characteristics:

- attenuation that follows a \sqrt{f} law with values throughout the range 0 dB to 12 dB at 17 184 kHz; and
- characteristic impedance of 75 Ω with a tolerance of ± 20 % over the frequency range from 860 kHz to 51 550 kHz.

Test: The test shall be conducted according to clause A.2.4.

4.2.2.4 Immunity against reflections

Requirement: When a signal comprising a combination of a normal signal and an interfering signal is applied to the input port, via an artificial cable with a loss in the range 0 dB to 12 dB at 17 184 kHz, no errors shall result due to the interfering signal. The normal signal shall be a signal encoded according to HDB3, shaped according to the mask of figure 2, with a binary content in accordance with a PRBS($2^{23}-1$). The interfering signal shall be the same as the normal signal except that the level shall be attenuated by 20 dB, the bit rate shall be within 34 368 kbit/s ± 20 ppm and the timing shall not be synchronized to the normal signal.

Test: The test shall be conducted according to clause A.2.4.

4.2.2.5 Input jitter tolerance

Requirement: The terminal equipment shall tolerate at its input port the maximum input jitter as shown in figure 3 and table 5 (taken from ITU-T Recommendation G.823 (see annex E)).

NOTE: Terminal equipment with more than one input will normally need to be designed with a wander buffer of at least 18 microseconds, however, to accommodate the wander that may be produced by Synchronous Digital Hierarchy (SDH) networks, up to 40 microseconds may be needed.

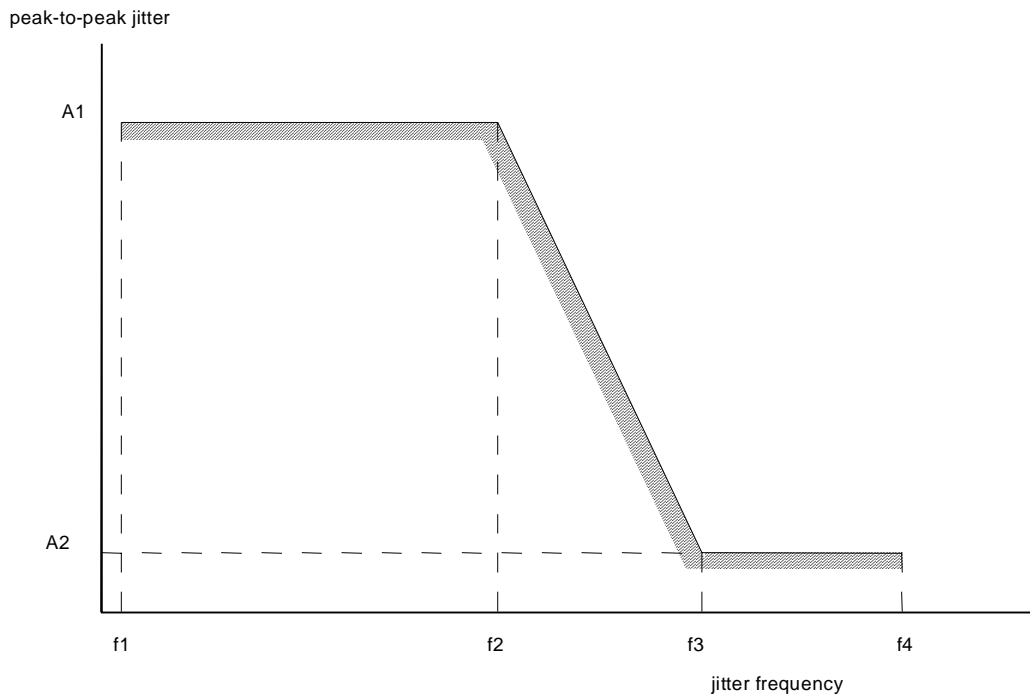

Figure 3: Input jitter tolerance

Table 5: Input jitter tolerance

Peak-to-peak amplitude (UI)		Frequency			
A1	A2	f1	f2	f3	f4
1,5	0,15	100 Hz	1 kHz	10 kHz	800 kHz

Test: The test shall be conducted according to clause A.2.7.

4.2.2.6 Input clock tolerance

Requirement: The terminal equipment shall decode without error HDB3 encoded signals, as defined in annex B, for all bit rates within the limits of 34 368 kbit/s \pm 20 ppm.

Test: The test shall be conducted according to clause A.2.7.

4.2.2.7 Input frame structure

The requirement of this clause applies to terminal equipment for connection to the D34S leased line. For terminal equipments for connection to the D34U leased line, there is no requirement on the structure of the input bit stream.

Requirement: The input port shall accept an input bit stream with a frame structure as defined in annex C. The terminal equipment shall be capable of achieving frame alignment, as detailed in clause 4.2.2.8, in order to separate the user data from the frame information.

Test: The test shall be conducted according to clause A.2.4.

4.2.2.8 Frame alignment procedure

The requirement of this clause applies to terminal equipment for connection to the D34S leased line. For terminal equipments for connection to the D34U leased line, there is no requirement on the frame alignment procedure.

Requirement: The terminal equipment shall perform a frame alignment procedure on the 34 368 kbit/s signal in order to gain or to recover frame alignment. To obtain frame alignment, the terminal equipment shall search for the FA1, FA2 bytes contained within the received bit stream. Frame alignment shall be continuously checked with the presumed frame start position for the correct frame alignment.

Frame alignment shall be considered to have been obtained, or recovered, when three consecutive non-errored frame alignment signals (FA1 and FA2) have been found.

Frame alignment shall be considered to have been lost when either:

- a) four consecutive frame alignment signals (FA1 and FA2) are detected in error (i.e. ≥ 1 error in each FA1 and FA2); or
- b) 986 or more frames with one or more BIP-8 violations are detected in a block of 1 000 frames.

When frame alignment is achieved, even bit parity (BIP-8) shall be computed by the terminal equipment for each bit n of every byte of the preceding frame and compared with bit n of the EM byte recovered from the current frame. A difference between the computed BIP-8 and the EM value shall be taken as evidence of one or more errors in the previous frame.

Should a research for frame alignment be initiated for any reason, then the new search for frame alignment should start 1 bit displaced forward from the position of the last indication of frame alignment.

NOTE: The above is recommended in order to avoid repeated alignment on to a simulation of the framing location.

Test: The test shall be conducted according to clause A.2.9.

4.3 Safety

Requirements for safety are outside the scope of the present document.

Safety standards are published by CENELEC.

NOTE 1: An example of such a CENELEC product safety standard is EN 60950 (see annex E).

NOTE 2: For safety categories of interfaces, see EG 201 212 (see annex E). This document is also available from CENELEC as ROBT-002.

4.4 Overvoltage

Overvoltage aspects are outside of the scope of the present document.

4.5 ElectroMagnetic Compatibility (EMC)

EMC requirements are outside the scope of the present document.

Annex A (normative): Test methods

A.1 General

This annex describes the test principles to determine the compliance of a terminal equipment against the requirements of the present document.

It is outside the scope of this annex to identify the specific details of the implementation of the tests.

A terminal equipment may be designed for through-connecting and may fulfil the electrical requirements only if through-connected. In these cases the requirements of the present document are valid and the tests shall be carried out with the through-connection terminated as specified by the manufacturer.

Details of test equipment accuracy and the specification tolerance of the test devices are not included in all cases. Where such details are provided they shall be complied with, but the way they are expressed shall not constrain the method of implementing the test.

NOTE: Attention is drawn to the issue of measurement uncertainty which may be addressed in future documents. Not all the required test results make allowance for spurious events during testing (e.g. errors due to EMC effects), which may make it necessary to repeat a test.

The test configurations given do not imply a specific realization of test equipment or test arrangement, or the use of specific test devices for conformance testing. However, any test configuration used shall provide those test conditions specified under "interface state", "stimulus" and "monitor" for each individual test.

The test equipment shall be a device, or a group of devices, that is capable of generating a stimulus signal conforming to the present document and capable of monitoring the signal received from the interface.

A.1.1 Additional information to support the test

The following facilities shall be provided by the terminal equipment interface under test:

- a) an ability to configure the terminal equipment such that it provides a transparent loopback of the data contained within the payload at the input to the output; and
- b) an ability to transmit a given bit pattern, e.g. PRBS(2²³-1), within the payload; or
- c) where a or b cannot be provided, an alternative means of performing the test.

NOTE: Where the terminal equipment is for connection to the D34S leased line, the REI bit may be used as an alternative to a transparent loopback in order to determine if data at the input has been correctly received.

A.1.2 Equipment connection

The tests shall be applied at the sockets or plugs defined in clauses 4.1.1 and 4.1.2. Connecting cable between the sockets and test equipment shall be kept to a minimum, except where cable is specified as part of the test.

Where plugs are provided at the end of a cord as defined in clause 4.1.2, the tests specified in clauses A.2.2, A.2.5 and A.2.6 may be performed at the point of connection of the cord to the terminal equipment, since the requirements are based on ITU-T Recommendation G.703 [4] which makes no allowance for any plug and cord.

A.2 Test methods

One test may cover more than one requirement. The scope of each test is defined under the heading "purpose".

A.2.1 Signal coding at the output port

Purpose: To verify that the signal coding at the terminal equipment output port complies with the HDB3 coding rules as required by clause 4.2.1.1.

Test configuration: Figure A.1.

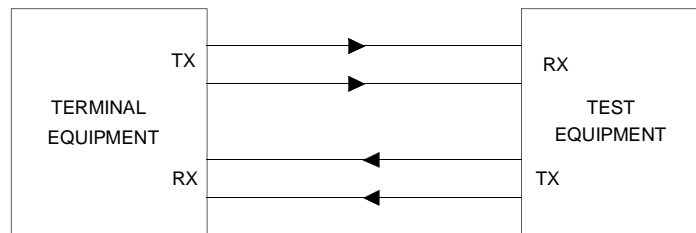

Figure A.1: Signal coding at output port

Interface state: Powered.

Stimulus: The terminal equipment shall transmit a bit stream including the sequences <0000><even number of binary ONES><0000> and <0000><odd number of binary ONES><0000> which shall be encoded into HDB3; where 0 = space and 1 = mark input to the HDB3 encoder, (see note).

NOTE: A pseudo random bit stream, e.g. PRBS($2^{23}-1$), will be acceptable if the bit patterns of the above clause are included in the bit stream. For terminal equipment which can generate a structured signal in accordance with annex C, the PRBS may be transmitted in the payload section of the frame. For terminal equipment which cannot generate such a structured signal, the PRBS should be transmitted in the whole bit stream.

Monitor: The output bit stream for a test period of sufficient time to allow transmission of 100 occurrences of the above patterns plus the latency period of the error detection mechanism.

Results: There shall be no errors in the HDB3 encoding.

A.2.2 Waveform shape at the output port

Purpose: To verify conformance of the output waveform shape with the requirements of clause 4.2.1.2.

Test configuration: Figure A.2.

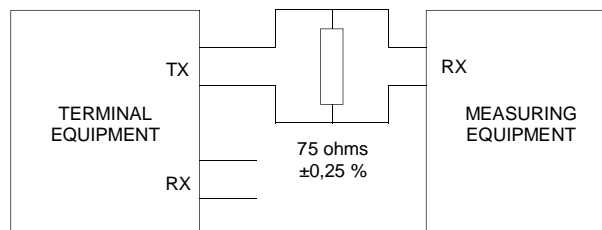

Figure A.2: Waveform shape at output port

Interface state: Powered.

Stimulus: Undefined.

Monitor: Marks and spaces transmitted from the terminal equipment, measuring the amplitude and shape of positive and negative pulses (measured at the centre of the pulse interval) and the time duration of positive and negative pulses (measured at the nominal half of the pulse amplitude, i.e. 0,5 V).

The overall measurement accuracy shall be better than 30 mV. All the measurements shall be performed using measuring equipment capable of recording dc. A bandwidth of 200 MHz or greater shall be used to ensure the capture of over or undershoot of the pulse.

Results: Both positive and negative pulses shall be within the mask of figure 2, where the nominal pulse amplitude is 1 V.

The bit interval corresponding to a space shall not present voltages higher than $\pm 0,1$ V.

The ratio between the amplitude of positive and negative pulses shall be in the range from 0,95 to 1,05.

The ratio between the pulse widths of positive and negative pulses shall be in the range from 0,95 to 1,05.

A.2.3 Output timing

Purpose: To measure the output timing as defined in clause 4.2.1.3.

Test Configuration: Figure A.3.

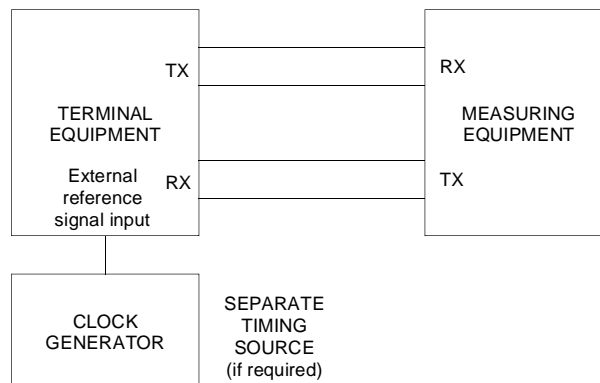

Figure A.3: Output timing

Interface state: Powered.

Stimulus: The terminal equipment shall be configured to provide output timing from each of its intended timing arrangements. Any external reference signal input, including the input port, from which timing can be derived, shall be provided with timing at the bit rate limits as specified by the terminal equipment manufacturer.

Monitor: The bit rate of the signal decoded from output port of the terminal equipment.

Results: The bit rate shall be within the limits given in clause 4.2.1.3.

A.2.4 Input signal coding, loss tolerance and immunity against reflections

Purpose: To verify the input port signal coding (clause 4.2.2.1) and immunity against an interfering signal combined with the input signal, (clause 4.2.2.4), both without cable (i.e. 0 dB attenuation loss) and with a cable attenuation of 12 dB (clause 4.2.2.3).

Test configuration: Figure A.4.

The interfering signal shall be combined with the main signal in a combining network of impedance 75Ω , with zero dB loss in the main path and an attenuation in the interference path of 20 dB.

The cable simulator shall have an attenuation of 12 dB measured at 17 184 kHz and an attenuation characteristic that follows a \sqrt{f} law over the frequency range 860 kHz to 51 550 kHz.

The conformance of the interface shall be verified in the following test conditions:

- without cable simulator and without interfering signal; and
- with cable simulator and without interfering signal; and
- without cable simulator and with interfering signal; and
- with cable simulator and with interfering signal.

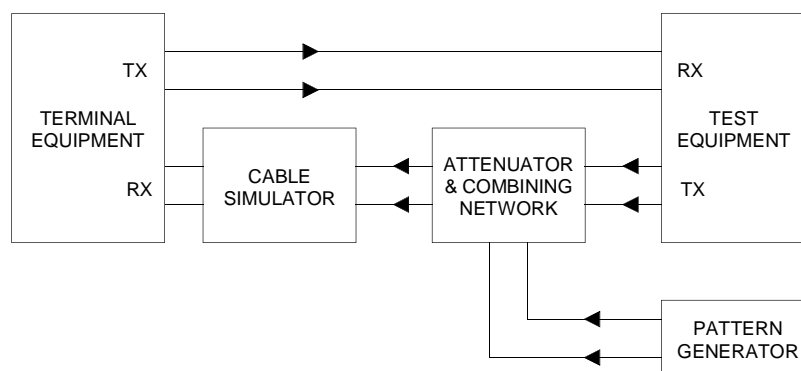

Figure A.4: Input coding, loss tolerance and immunity against reflections

Interface state: Powered, with received data looped back to the output port.

Stimulus: The output signal of the test equipment shall be HDB3 encoded and conform to a pulse shape as defined in figure 17 of ITU-T Recommendation G.703 [4], which is reproduced in figure 2 of the present document. For terminal equipment which can generate a structured signal in accordance with annex C, the bit stream shall be structured into frames according to annex C. The binary content of the data contained in the payload of the frame shall be a PRBS($2^{23}-1$). For terminal equipment which cannot generate such a structured signal, the PRBS should be transmitted in the whole bit stream.

The bit rate shall be within the limits $34\,368 \text{ kbit/s} \pm 20 \text{ ppm}$.

The interfering signal from the pattern generator shall:

- be HDB3 encoded and conform to a pulse shape as defined in figure 17 of ITU-T Recommendation G.703 [4], which is reproduced in figure 2 of the present document; and
- have a binary content with a PRBS($2^{23}-1$); and
- have a nominal bit rate of $34\,368 \text{ kbit/s}$, not synchronized to the output signal of the test equipment.

- Monitor:** Data at the output port of the terminal equipment.
- Results:** There shall be no bit errors reported for at least one minute.

A.2.5 Input return loss

Purpose: To verify the return loss of the input port of the terminal equipment complies with the requirement of clause 4.2.2.2.

Test configuration: Figure A.5.

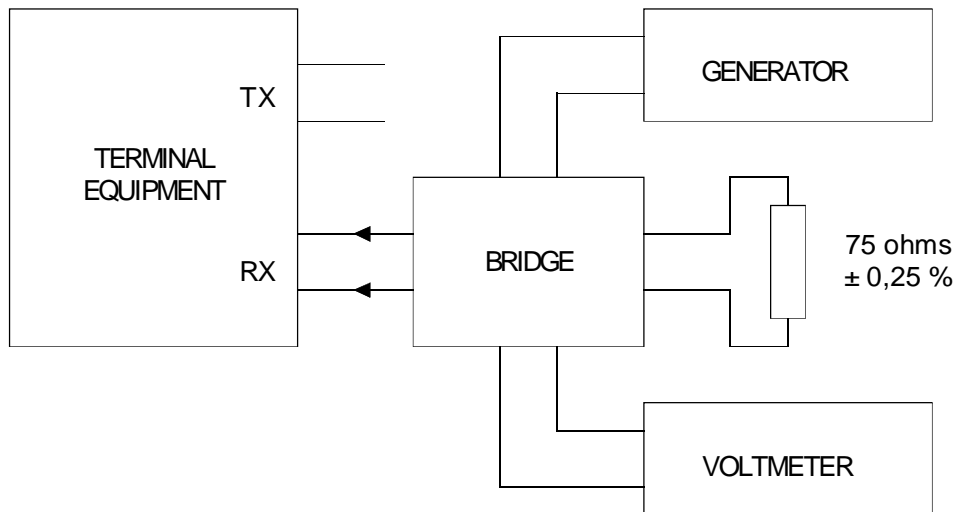

Figure A.5: Return loss at input port

- Interface state:** Powered.
- Stimulus:** Sinusoidal signal of 1 V peak applied to the input of the terminal equipment with a frequency variable between the limits of 860 kHz and 51 550 kHz.
- Monitor:** Voltage measured across the bridge, representing a terminating resistor of 75 Ω using a selective voltmeter with a bandwidth of less than 10 kHz.
- Results:** The measured return loss shall be greater than or equal to the values specified in clause 4.2.2.2.

NOTE 1: The characteristics of the generator and of the voltmeter may be different depending on the implementation of the bridge, however the total error of the test set-up should be less than 0,5 dB in the range between 10 dB and 20 dB. When connected to a 75 Ω ± 0,25 % resistor, the measured return loss of the bridge should be 20 dB higher than the limits specified for the interface.

NOTE 2: Where the generator and voltmeter are implemented by means of a network analyser, a measurement bandwidth of 100 Hz and a sweep time of 10 s is recommended.

A.2.6 Output return loss

Purpose: To verify the return loss of the output port of the terminal equipment complies with the requirement of clause 4.2.1.4.

Test configuration: Figure A.6.

Interface state: Powered.

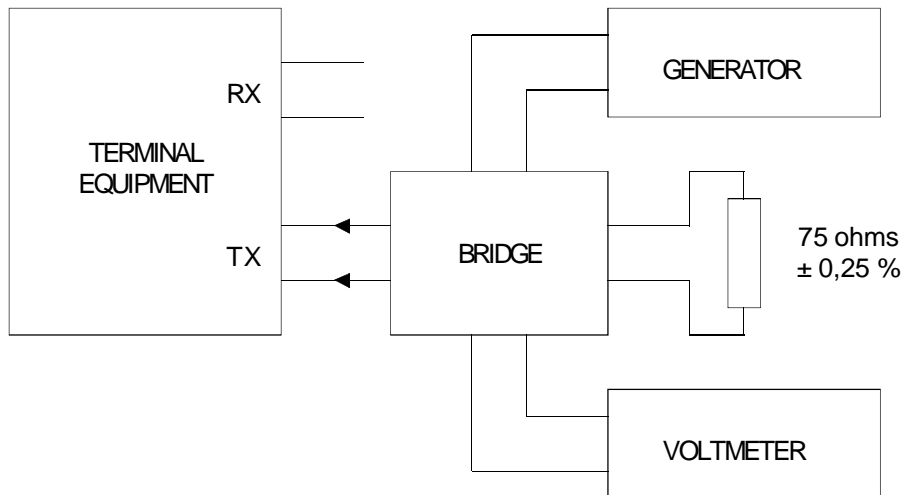

Figure A.6: Return loss at output port

Stimulus: Sinusoidal signal of 1 V peak applied to the output of the terminal equipment interface with a frequency variable between the limits of 860 kHz and 51 550 kHz.

The output return loss shall be measured under dynamic conditions with a PRBS(2²³-1) transmitted at the output. For a terminal equipment which can generate a structured signal in accordance with the present document, the PRBS may be transmitted in the payload section of the frame. For a terminal equipment which cannot generate such a structured signal, the PRBS should be transmitted in the whole bit stream.

Monitor: Voltage measured across the bridge, representing a terminating resistor of 75 Ω using a selective voltmeter with a bandwidth of less than 10 kHz.

Results: The measured return loss shall be greater than or equal to the values specified in clause 4.2.1.4.

NOTE 1: The characteristics of the generator and of the voltmeter may be different depending on the implementation of the bridge however the total error of the test set-up should be less than 0,5 dB in the range between 10 dB and 20 dB. When connected to a 75 Ω ± 0,25 % resistor the measured return loss of the bridge should be 20 dB higher than the limits specified for the interface.

NOTE 2: Where the generator and voltmeter are implemented by means of a network analyser, a measurement bandwidth of 100 Hz and a sweep time of 10 s is recommended to restrict the influence of the output signal on the test result.

A.2.7 Input and output jitter

Purpose: To measure tolerance to input jitter (clause 4.2.2.5), maximum output jitter (clause 4.2.1.5) and operation over the specified input timing range (clause 4.2.2.6).

NOTE: Further information on the measurement of jitter can be found in ITU-T Supplement number 3.8 (see annex E).

Test Configuration: Figure A.7.

The terminal equipment shall be tested in each of the following configurations (where these modes of operation are supported):

- a) output timing referenced to the internal clock; and
- b) output timing referenced to any external clock source from which timing can be derived (including derivation from the input signal).

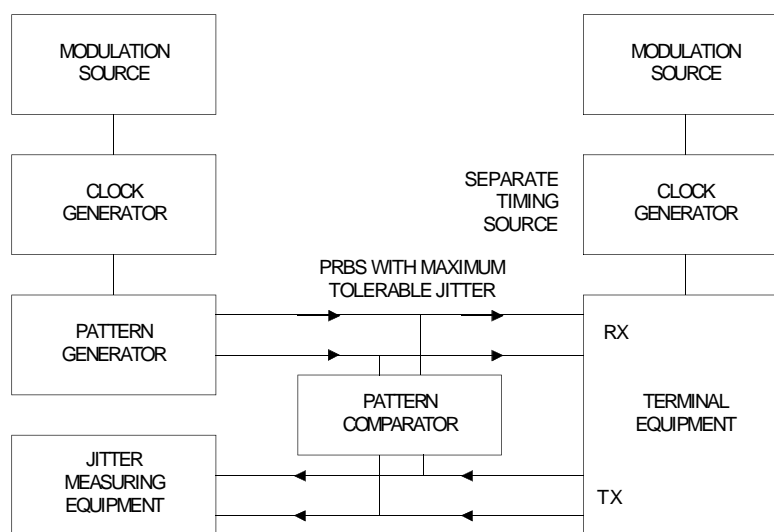

NOTE: The modulation source may be included in the clock generator and/or the pattern generator, or it may be provided separately.

Figure A.7: Jitter measurement

Interface state: Powered, with received data looped back to the output port.

Stimulus: The output signal of the test equipment shall be HDB3 encoded and conform to a pulse shape as defined in figure 17 of ITU-T Recommendation G.703 [4], which is reproduced in figure 2 of the present document. For terminal equipment which can accept a structured signal in accordance with annex C, the bit stream shall be structured into frames according to annex C. The binary content of the data contained in the payload of the frame shall be a PRBS(2²³-1). For terminal equipment which cannot accept such a structured signal, the PRBS should be transmitted in the whole bit stream.

Measurements shall be made with both the input signals at the digital rate limits of 34 368 kbit/s \pm 20 ppm and between these limits, sufficient to verify jitter compliance over the specified frequency range. As a minimum the test shall be performed at the upper and lower limits and at the nominal rate.

The modulation source for the terminal equipment input bit stream shall generate individual components of sinusoidal jitter at points on the curve of figure 3 and table 4 of the present document.

The modulation source for the external timing (if needed) shall be independent from that for the input signal and shall generate the maximum tolerable jitter, and maximum frequency deviation, as specified by the manufacturer of the terminal equipment.

It may be necessary to synchronize the two clock generators to avoid a high occurrence of slips.

- Monitor:**
- a) the signal transmitted by the terminal equipment; and
 - b) the jitter extracted from this signal using equipment complying with ITU-T Recommendation O.171 [6].
- Results:**
- a) there shall be no bit errors reported by the test equipment within the period of the test; and
 - b) the peak-to-peak jitter shall comply with the requirements of clause 4.2.1.5.

A.2.8 Frame structure

Purpose: To verify compliance with the requirements for terminal equipment output structure defined in clause 4.2.1.6. The test verifies the presence of the frame alignment signals (FA1 and FA2), the BIP-8, trail trace, MA byte (RDI, REI, payload type, payload dep and TM) and the general purpose communications channel.

Test configuration: See figure A.8.

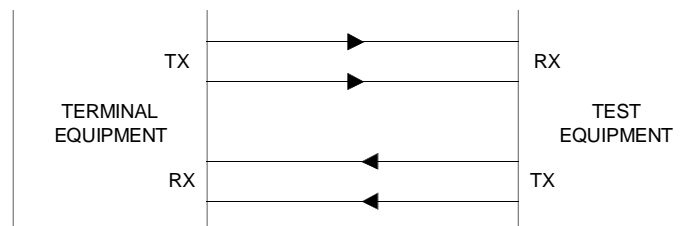

Figure A.8: Structure

Interface state: Powered.

Stimulus: The following HDB3 encoded stimuli shall be applied to the input of the terminal equipment at a bit rate within the limits of $34\,368\text{ kbit/s} \pm 20\text{ ppm}$:

- a) a bit stream structured in accordance with annex C;
- b) a bit stream structured in accordance with annex C, with bit errors introduced in the payload following calculation of the BIP-8;
- c) a continuous all one signal (AIS);
- d) no signal (input disconnected);
- e) a continuous PRBS($2^{23}-1$) with no frame structure.

Monitor: The bit stream at the output of the terminal equipment.

Results: The output bit stream shall comprise frames of octets commencing with the two octets FA1 and FA2 as defined in annex C.

- a) The BIP-8 contained in the EM byte shall correspond to the previous frame in accordance with the requirements of annex C; RDI = 0; REI = 0; the trail trace byte, payload type, payload dependent bits and TM shall be as declared by the terminal equipment manufacturer;
- b) REI shall be set to 1 for a period of 1 frame, for each frame received where the BIP-8 does not correspond with the data;
- c) RDI = 1;
- d) RDI = 1;
- e) RDI = 1.

A.2.9 Frame alignment procedure

Purpose: To verify the compliance with the requirements for frame alignment procedure (see clause 4.2.2.8). The test verifies the detection of loss of frame and regaining of frame and the associated setting of the RDI (see clause 4.2.1.6).

Test configuration: See figure A.9.

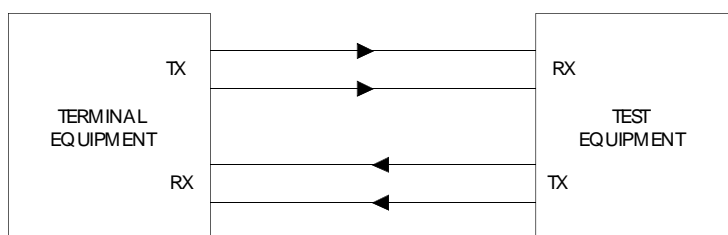

Figure A.9: Frame alignment

Interface state: Powered.

Stimulus: The following HDB3 encoded signal shall be applied to the input of the terminal equipment at a bit rate within the limits of $34\,368\text{ kbit/s} \pm 20\text{ ppm}$. The bit stream shall be structured in accordance with annex C but with the following modification of the frame alignment word and the EM byte.

Table A.1: Frame alignment procedure

Stimulus	Result	Comment
...F F F F F ...	RDI=0	correct FAS
...F F F F /F /F /F F F ...	RDI=0	3 incorrect FAS
...F F F F N*(/F /F /F /F F F)	RDI=1	4 incorrect FAS
/F /F /F /F F F F	RDI=0	
/F F F /F	RDI=0	
F F F F ...	RDI=0	
...985 BIP-8 errors in 1 000 frames	RDI=0	
...986 BIP-8 errors in 1 000 frames	RDI=1	
F F F F...	RDI=0	
/F /F /F /F ... Simulated FA1, FA2 and correct BIP-8 in the payload. After locking of simulated frame consecutive F and EM, 986 incorrect BIP-8 in the payload. F F F F	RDI=1 RDI=0 RDI=1 RDI=0	New FAS should be searched with 1 bit offset
NOTE: F = correct frame alignment signal. /F = incorrect frame alignment signal. N* = repeat continuously N times (where N is an integer).		

Monitor: The RDI signal at the output port.

Result: The setting of the RDI shall conform to column 2 of table A.1.

Annex B (normative): Definition of HDB3 code

B.1 General

This annex specifies the modified Alternate Mark Inversion (AMI) code HDB3. The contents of this annex are based on annex A of ITU-T Recommendation G.703 [4].

In this code, binary 1 bits are represented by alternate positive and negative pulses, and binary 0 bits by spaces. Exceptions are made when strings of successive 0 bits occur in the binary signal.

In the definition below, B represents an inserted pulse corresponding to the AMI rule, and V represents an AMI violation.

B.2 Definition

Each block of 4 successive zeros is replaced by 000V or B00V. The choice of 000V or B00V is made so that the number of B pulses between consecutive V pulses is odd. In other words, successive V pulses are of alternate polarity so that no dc component is introduced.

Annex C (normative): Definition of frame structure

C.1 Frame structure at 34 368 kbit/s

The basic frame structure at 34 368 kbit/s for the D34S leased line shall comprise 7 octets of generic path overhead and 530 octets of payload capacity; this is defined in figures C.1 and C.2. The order of transmission of information in figure C.1 is first from left to right and then top to bottom. Within each byte the most significant bit is transmitted first. The most significant bit (bit 1) is illustrated at the left of figure C.2.

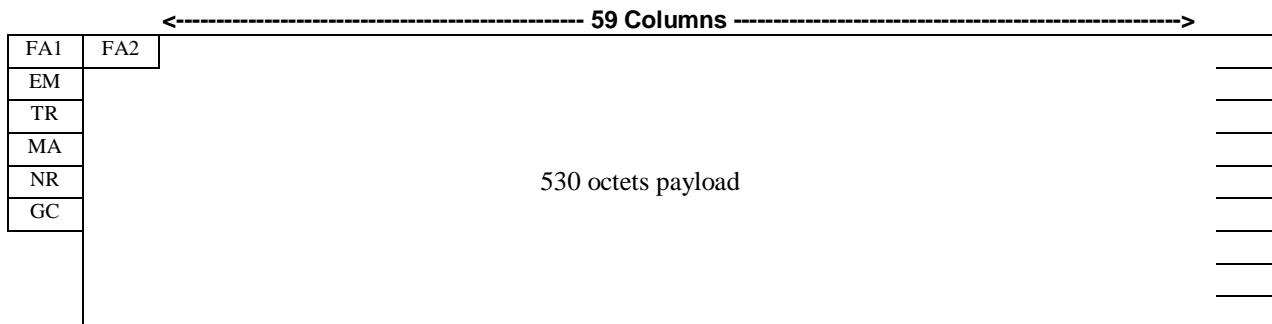

Figure C.1: Frame structure at 34 368 kbit/s

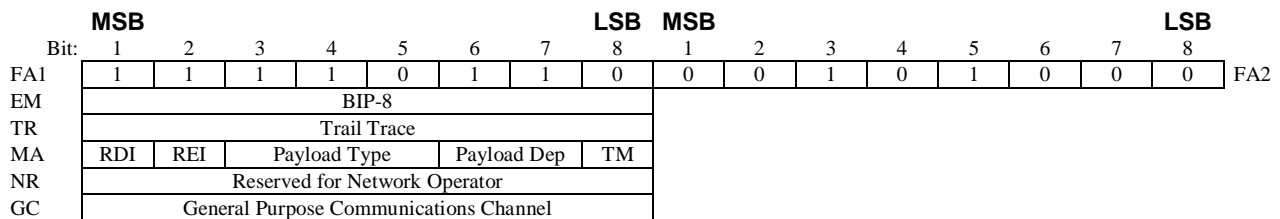

Figure C.2: Path overhead at 34 368 kbit/s

- MSB Most Significant Bit.
- LSB Least Significant Bit.
- FA1 Frame Alignment byte (1).
- FA2 Frame Alignment byte (2).
- EM Error Monitoring, Bit Interleaved Parity - 8 (BIP-8). One byte is allocated for path error monitoring. This function shall be a BIP-8 code using even parity. The path BIP-8 is calculated over all bits of the previous 125 μ s frame. The computed BIP-8 is placed in the EM byte of the current 125 μ s frame.
- TR TRail trace. This byte is used to transmit repetitively a trail access point identifier so that a trail receiving terminal can verify its continued connection to the intended transmitter. See clause C.1.1.

MA Maintenance and Adaptation Byte:

Bit 1 RDI Remote Defect Indication: this bit is set to "1" under the following conditions:

- a) invalid input signal or loss of signal (LOS);
- b) loss of frame alignment (LOF) see note 1; or
- c) alarm indication signal (AIS);

and is otherwise set to "0".

NOTE 1: RDI may also be set in the event of a trail trace mismatch.

Bit 2 REI Remote Error Indication: this bit is set to "1" and sent back to the remote path termination if one or more errors were detected by the BIP-8, and is otherwise set to "0".

Bits 3 - 5 Payload type: these bits are set as shown in table C.1.

Table C.1: Payload type

Code	Signal
000	Unequipped
001	Equipped, non-specific
010	ATM
011	SDH TU-12s

Bits 6 - 7 Payload dependent: e.g. Tributary Unit (TU) multiframe indicator.

NOTE 2: Further information on the multiplexing of SDH elements within the payload and the use of the payload dependent bits is given in ETS 300 337 (see annex E).

Bit 8 TM Timing Marker: this bit is set to "0" to indicate that the timing source is traceable to a primary reference clock and is otherwise set to "1".

NR Network operator byte. This byte is undefined for terminal equipments.

NOTE 3: This byte is allocated for maintenance purposes specific to individual network operators. Its transparency from NTP to NTP is not guaranteed.

GC General purpose Communications channel (e.g. to provide data/voice channel connection for maintenance purposes). The specific use of this byte is undefined within the present document.

NOTE 4: This byte is allocated for the specific use of the terminal equipment user. Its transparency from NTP to NTP is guaranteed.

NOTE 5: The specific use of this byte is under study within other ETSI Technical Committees.

C.1.1 Trail access point identifier format

The trail access point identifier shall use the 16-byte numbering format described below.

The first byte of the string is a frame start marker and includes the result of a Cyclic Redundancy Check (CRC-7) calculation over the previous frame. The following 15 bytes are used for the transport of 15 American Standard Code for Information Interchange (ASCII) characters supplied by the leased line provider for each leased line. This code will be different in each direction of transmission.

NOTE: The ASCII code is specified in ITU-T Recommendation T.50 (see annex E).

The 16-byte frame is defined in figure C.3.

Byte 1	1	C ₁	C ₂	C ₃	C ₄	C ₅	C ₆	C ₇	Frame start marker
Byte 2	0	X	X	X	X	X	X	X	
Byte 3	0	X	X	X	X	X	X	X	
Byte 16	0	X	X	X	X	X	X	X	

NOTE: C₁ --- C₇ Result of the CRC-7 calculation over the previous frame.
 0XXXXXXX ASCII Character.

Figure C.3: 16-byte frame

The description of the CRC-7 calculation is given below.

C.1.1.1 CRC-7 calculation - multiplication and division process

A particular CRC-7 word is the remainder after multiplication by x^7 and then division (modulo 2) by the generator polynomial $x^7 + x^3 + 1$, of the polynomial representation of the previous Trail Trace Identifier (TTI) multiframe.

When representing the contents of the block as a polynomial, the first bit in the block (i.e. byte 1 bit 1) shall be taken as being the MSB. Similarly, C₁ is defined to be the MSB of the remainder and C₇ to be the LSB of the remainder.

C.1.1.2 CRC-7 calculation - encoding procedure

Contrary to e.g. CRC-4 procedure in a 2 048 kbit/s signal, the CRC-7 word is static because the data is static (the TTI represents the source address). This means that the CRC-7 checksum can be calculated a priori over the TTI multiframe. For consistency with existing Recommendations, the CRC-7 shall be calculated over the previous multiframe. In theory this means that the 16-byte string that is loaded in a device for repetition transmission should have the checksum as the last byte, although in practice it does not really matter, because the TTI is static.

The encoding procedure is as follows:

- the CRC-7 bits in the TTI are replaced by binary 0 s;
- the TTI is then acted upon by the multiplication/division process referred to above;
- the remainder resulting from the multiplication/division process is inserted into the CRC-7 location.

The CRC-7 bits generated do not affect the result of the multiplication/division process because, as indicated in a) above, the CRC-7 bit positions are initially set to 0 during the multiplication/division process.

C.1.1.3 CRC-7 calculation - decoding procedure

The decoding procedure is as follows:

- a received TTI is acted upon by the multiplication/division process referred to above after having its CRC-7 bits extracted and replaced by binary 0 s;
- the remainder resulting from the multiplication/division process is then compared on a bit-by-bit basis with the CRC-7 bits received;
- if the remainder calculated in the decoder exactly corresponds to the CRC-7 bits received, it is assumed that the checked TTI is error free.

Annex D (normative): Requirements Table (RT)

Notwithstanding the provisions of the copyright clause related to the text of the present document, ETSI grants that users of the present document may freely reproduce the RT proforma in this annex so that it can be used for its intended purposes and may further publish the completed RT.

Table D.1: Conditions table for attachment requirements for terminal equipment to digital 34 Mbit/s leased lines (D34U and D34S) as given in EN 300 689

Reference	Condition	Status	Support (Y/N)
C.1	Is the terminal equipment intended for connection to the D34S leased line?	If YES then M else N	

Table D.2: RT for attachment requirements for terminal equipment to digital 34 Mbit/s leased lines (D34U and D34S) as given in EN 300 689

Reference		EN 300 689		
Item	Reference to the clause	Requirement	Status (note 1)	Support (note 2)
1	4.1.1	Sockets	O.1	
2	4.1.2	Plugs	O.1	
3	4.2.1.1	Signal coding	M	
4	4.2.1.2	Waveform shape	M	
5	4.2.1.3	Output timing	M	
6	4.2.1.3 (a)	- internal source of timing	O	
7	4.2.1.3 (b)	- external timing reference (note 3)	O	
8	4.2.1.3 (c)	- timing derived from input port	O	
9	4.2.1.4	Output return loss	M	
10	4.2.1.5	Output jitter	M	
11	4.2.1.6	Output frame structure	C.1	
12	4.2.2.1	Signal coding	M	
13	4.2.2.2	Input return loss	M	
14	4.2.2.3	Input loss tolerance	M	
15	4.2.2.4	Immunity against reflections	M	
16	4.2.2.5	Input jitter tolerance	M	
17	4.2.2.6	Input clock tolerance	M	
18	4.2.2.7	Input frame structure	C.1	
19	4.2.2.8	Frame alignment procedure	C.1	
20	4.3	Safety	M	
21	4.4	Overvoltage protection	N	
22	4.5	ElectroMagnetic Compatibility	N	
NOTE 1: Status is "Mandatory (M)", "Not a requirement (N)", "Optional (O)" or "Conditional (C.x)". For Conditional see table D.1. O.n indicates that one or more of the numbered options shall be provided from the set n.				
NOTE 2: The support column has been added to the requirements table so that the table may be used as an implementation conformance statement proforma. Support is Y (equipment conforms to the standard), X (equipment does not conform to the present document), N (equipment does not claim to conform to the present document).				
NOTE 3: Where the timing may be derived from an external reference signal, the terminal equipment supplier shall declare the maximum input jitter and maximum timing deviation of this signal for the purpose of testing the output jitter limits of clause 4.2.1.5.				

Annex E (informative): Bibliography

Council Directive 91/263/EEC of 29 April 1991 on the approximation of the laws of the Member States concerning telecommunications terminal equipment, including the mutual recognition of their conformity.

Council Directive 92/44/EEC of 5 June 1992 on the application of Open Network Provision to leased lines.

Directive 98/13/EC of the European Parliament and of the Council of 12 February 1998 relating to telecommunications terminal equipment and satellite earth station equipment, including the mutual recognition of their conformity.

CENELEC EN 50310: "Application of equipotential bonding and earthing at premises with information technology equipment".

ITU-T Recommendation G.823 (2000): "The control of jitter and wander within digital networks which are based on the 2 048 kbit/s hierarchy".

ITU-T Recommendation T.50: "International Reference Alphabet (IRA) (Formerly International Alphabet No. 5 or IA5) - Information technology - 7-bit coded character set for information interchange".

ETSI TBR 24: "Business TeleCommunications (BTC); 34 Mbit/s digital leased lines (D34U and D34S), Attachment requirements for terminal equipment interface".

CENELEC EN 60950 Safety of information technology equipment

ETSI EG 201 212: "Electrical safety; Classification of interfaces for equipment to be connected to telecommunication networks". This document is also available from CENELEC as ROBT-002.

History

Document history		
Edition 1	December 1996	Publication as ETS 300 689
V1.2.1	February 2001	One-step Approval Procedure OAP 20010629: 2001-02-28 to 2001-06-29
V1.2.1	July 2001	Publication