

Draft **ETSI EN 300 676** V1.2.1 (1999-12)

---

*European Standard (Telecommunications series)*

**Electromagnetic compatibility and  
Radio spectrum Matters (ERM);  
Ground-based VHF hand-held, mobile and fixed radio  
transmitters, receivers and transceivers for the VHF  
aeronautical mobile service using amplitude modulation;  
Technical characteristics and methods of measurement**

---



---

**Reference**

REN/ERM-RP05-014

---

**Keywords**

Aeronautical, AM, DSB, radio, testing, VHF

**ETSI**

---

**Postal address**

F-06921 Sophia Antipolis Cedex - FRANCE

---

**Office address**

650 Route des Lucioles - Sophia Antipolis  
Valbonne - FRANCE  
Tel.: +33 4 92 94 42 00 Fax: +33 4 93 65 47 16  
Siret N° 348 623 562 00017 - NAF 742 C  
Association à but non lucratif enregistrée à la  
Sous-Préfecture de Grasse (06) N° 7803/88

---

**Internet**

secretariat@etsi.fr  
Individual copies of this ETSI deliverable  
can be downloaded from  
<http://www.etsi.org>  
If you find errors in the present document, send your  
comment to: editor@etsi.fr

---

**Important notice**

This ETSI deliverable may be made available in more than one electronic version or in print. In any case of existing or perceived difference in contents between such versions, the reference version is the Portable Document Format (PDF). In case of dispute, the reference shall be the printing on ETSI printers of the PDF version kept on a specific network drive within ETSI Secretariat.

---

**Copyright Notification**

No part may be reproduced except as authorized by written permission.  
The copyright and the foregoing restriction extend to reproduction in all media.

© European Telecommunications Standards Institute 1999.  
All rights reserved.

# Contents

Intellectual Property Rights .....	7
Foreword.....	7
Introduction .....	7
1 Scope .....	8
2 References .....	8
3 Definitions and abbreviations .....	8
3.1 Definitions .....	8
3.2 Abbreviations .....	9
4 General requirements .....	9
4.1 Controls and indicators.....	9
4.2 Class of emission and modulation characteristics.....	10
4.3 Warm up.....	10
5 Test conditions, power sources and ambient temperatures.....	10
5.1 Normal and extreme test conditions .....	10
5.2 Test power source.....	10
5.3 Normal test conditions.....	10
5.3.1 Normal temperature and humidity .....	10
5.3.2 Normal power sources .....	11
5.3.2.1 Mains voltage and frequency.....	11
5.3.2.2 Regulated lead-acid battery power sources used on vehicles .....	11
5.3.2.3 Other power sources.....	11
5.4 Extreme test conditions .....	11
5.4.1 Extreme temperatures .....	11
5.4.2 Extreme values of test power sources .....	11
5.4.2.1 Mains voltage.....	11
5.4.2.2 Other power sources.....	11
5.5 Performance test .....	12
5.6 Environmental tests .....	12
5.6.1 General.....	12
5.6.2 Procedure for tests at extreme temperatures .....	12
5.6.3 Temperature tests.....	13
5.6.3.1 High temperature.....	13
5.6.3.2 Low temperature .....	13
6 General conditions of measurement.....	13
6.1 Receiver test signal arrangement .....	13
6.1.1 Test signal sources .....	13
6.1.2 Nominal frequency.....	13
6.1.3 Normal test signal .....	13
6.1.4 Squelch .....	13
6.1.5 Normal audio output power .....	14
6.1.6 Audio AGC.....	14
6.2 Transmitter test signal arrangement.....	14
6.2.1 Coaxial termination.....	14
6.2.2 Signal sources .....	14
6.2.3 Normal test signal .....	14
6.3 Test channels .....	14
7 Transmitter .....	14
7.1 Protection of the transmitter .....	14
7.1.1 Definition.....	14
7.1.2 Method of measurement.....	14
7.1.3 Requirement.....	15

7.2	Frequency error .....	15
7.2.1	Definition .....	15
7.2.2	Method of measurement.....	15
7.2.3	Limits.....	15
7.3	Carrier power.....	15
7.3.1	Definitions .....	15
7.3.2	Method of measurement.....	15
7.3.3	Tolerances.....	16
7.3.3.1	Normal test conditions .....	16
7.3.3.2	Extreme test conditions .....	16
7.4	Amplitude modulation characteristic .....	16
7.4.1	Modulation depth (speech) .....	16
7.4.1.1	Definitions .....	16
7.4.1.2	Method of measurement .....	16
7.4.1.3	Limits .....	16
7.4.1.4	Modulation depth (data mode) .....	16
7.4.1.5	Method of measurement .....	16
7.4.1.6	Limits .....	16
7.4.2	Modulation compression (speech mode) .....	17
7.4.2.1	Definition .....	17
7.4.2.2	Method of measurement .....	17
7.4.2.3	Limits .....	17
7.4.3	Amplitude modulation distortion .....	17
7.4.3.1	Definition .....	17
7.4.3.2	Method of measurement .....	17
7.4.3.3	Limits .....	17
7.4.4	Audio frequency response.....	18
7.4.4.1	Definition .....	18
7.4.4.2	Method of measurement.....	18
7.4.4.3	Limits 8,33 kHz channel spacing .....	18
7.4.4.4	Limits 25 kHz channel spacing .....	18
7.4.5	Group delay variation (data mode only) .....	19
7.4.5.1	Definition .....	19
7.4.5.2	Transmitter method of measurement .....	19
7.4.5.3	Limits .....	19
7.5	Adjacent channel power .....	20
7.5.1	Definition.....	20
7.5.2	Measurement.....	20
7.5.3	Limits.....	20
7.6	Broadband noise measurement .....	20
7.6.1	Definition.....	20
7.6.2	Method of measurement.....	21
7.6.3	Limit .....	21
7.7	Conducted spurious emissions.....	22
7.7.1	Definition.....	22
7.7.2	Method of measurement.....	22
7.7.3	Limits.....	22
7.8	Intermodulation attenuation.....	23
7.8.1	Definition.....	23
7.8.2	Method of measurement.....	23
7.8.3	Limits.....	23
7.9	RF power attack time and release time .....	24
7.9.1	Definitions .....	24
7.9.2	Method of measurement.....	24
7.9.2.1	Attack time .....	24
7.9.2.2	Release time .....	25
7.9.3	Limits.....	25
7.10	Keying Transient frequency behaviour of the transmitter.....	25
7.10.1	Definitions .....	25
7.10.2	Method of measurement.....	26

7.10.3	Limits .....	26
8	Receiver .....	26
8.1	Sensitivity .....	26
8.1.1	Definition .....	26
8.1.2	Method of measurement .....	27
8.1.3	Limits .....	27
8.2	Harmonic distortion .....	27
8.2.1	Definition .....	27
8.2.2	Method of measurement .....	27
8.2.3	Limits .....	27
8.3	Audio frequency response .....	28
8.3.1	Definition .....	28
8.3.2	Method of measurement .....	28
8.3.3	Limits .....	28
8.3.4	Limit for ACARS Operation .....	28
8.4	Audio noise .....	28
8.4.1	Definition .....	28
8.4.2	Method of measurement .....	28
8.4.3	Limits .....	28
8.5	Effective Acceptance Bandwidth .....	29
8.5.1	Definition .....	29
8.5.2	Method of Measurement .....	29
8.5.3	Limits .....	29
8.6	Adjacent channel rejection .....	29
8.6.1	Definition .....	29
8.6.2	Method of measurement .....	29
8.6.3	Limits .....	30
8.7	Spurious response rejection .....	30
8.7.1	Definition .....	30
8.7.2	Introduction to the method of measurement .....	30
8.7.3	Method of search of the limited frequency range .....	31
8.7.4	Method of measurement .....	31
8.7.5	Limit .....	31
8.8	Intermodulation response rejection .....	31
8.8.1	Definition .....	31
8.8.2	Method of measurement .....	32
8.8.3	Limit .....	32
8.9	Blocking or desensitization .....	32
8.9.1	Definition .....	32
8.9.2	Method of measurement .....	33
8.9.3	Limit .....	33
8.10	Conducted spurious emissions .....	33
8.10.1	Definition .....	33
8.10.2	Method of measuring the power level .....	33
8.10.3	Limits .....	34
8.11	Squelch operation .....	34
8.11.1	Definition .....	34
8.11.2	Method of measurement .....	34
8.11.3	Limits .....	35
8.12	Cross modulation rejection .....	35
8.12.1	Definition .....	35
8.12.2	Method of measurement .....	35
8.12.3	Limits .....	36
8.13	Receiver dynamic range .....	36
8.13.1	Definition .....	36
8.13.2	Method of measurement .....	36
8.13.3	Limit .....	36
8.14	AGC attack time and release time (data mode only) .....	36
8.14.1	Definitions .....	36
8.14.2	Method of measurement .....	36

8.14.2.1	Attack time .....	36
8.14.2.2	AGC Decay time .....	37
8.14.3	Limits .....	37
8.15	AF AGC .....	37
8.15.1	Definition .....	37
8.15.2	Method of Measurement .....	37
8.15.3	Limit .....	37
8.16	Group delay variation (data mode only) .....	38
8.16.1	Definition .....	38
8.16.2	Receiver method of measurement .....	38
8.16.3	Limits .....	38
9	Measurement uncertainty and interpretation of the measured results .....	39
9.1	Maximum measurement uncertainties .....	39
9.2	Interpretation of the measurement results .....	40
<b>Annex A (normative):</b>	<b>Auxiliary cables.....</b>	<b>41</b>
<b>Annex B (normative):</b>	<b>Specification for adjacent channel power measurement arrangements .....</b>	<b>42</b>
B.1	Power measuring receiver specification.....	42
B.1.1	IF filter.....	42
B.1.2	Attenuation indicator .....	43
B.1.3	RMS value indicator.....	43
B.1.4	Oscillator and amplifier .....	43
	Bibliography .....	44
	History .....	45

---

## Intellectual Property Rights

IPRs essential or potentially essential to the present document may have been declared to ETSI. The information pertaining to these essential IPRs, if any, is publicly available for **ETSI members and non-members**, and can be found in SR 000 314: "*Intellectual Property Rights (IPRs); Essential, or potentially Essential, IPRs notified to ETSI in respect of ETSI standards*", which is available from the ETSI Secretariat. Latest updates are available on the ETSI Web server (<http://www.etsi.org/ipr>).

Pursuant to the ETSI IPR Policy, no investigation, including IPR searches, has been carried out by ETSI. No guarantee can be given as to the existence of other IPRs not referenced in SR 000 314 (or the updates on the ETSI Web server) which are, or may be, or may become, essential to the present document.

---

## Foreword

This European Standard (Telecommunications series) has been produced by ETSI Technical Committee Electromagnetic compatibility and Radio spectrum Matters (ERM), and is now submitted for the ETSI standards One-step Approval Procedure phase.

<b>Proposed national transposition dates</b>	
Date of latest announcement of this EN (doa):	3 months after ETSI publication
Date of latest publication of new National Standard or endorsement of this EN (dop/e):	6 months after doa
Date of withdrawal of any conflicting National Standard (dow):	6 months after doa

---

## Introduction

The present document states the minimum performance requirements for ground based radio transmitters, transceivers and receivers for the aeronautical mobile service operating in the VHF band (118 MHz to 136 975 MHz), using Double Sideband Amplitude Modulation with 8,33 kHz or 25 kHz channel spacing.

The present document may be used by accredited test laboratories for the assessment of the performance of the equipment. The performance of the equipment submitted for type testing should be representative for the performance of the corresponding production model.

The present document has been written on the assumption that:

- the type test measurements will be performed only once, in an accredited test laboratory and the measurements accepted by the various authorities in order to grant type approval;
- if equipment available on the market is required to be checked it will be tested in accordance with the methods of measurement specified in the present document.

---

# 1 Scope

The present document states the minimum performance requirements for radio transmitters receivers and transceivers at ground-based aeronautical stations operating in the VHF band (118 MHz to 136 975 MHz) allocated to the aeronautical mobile service.

The present document applies to DSB AM systems, with channel separations of 8,33 kHz or 25 kHz intended for analogue speech and ground base stations with a channel spacing of 25 kHz intended for ACARS data communication.

The scope of the present document is limited to ground base stations, ground mobile and hand held radios for ground use.

---

# 2 References

The following documents contain provisions which, through reference in this text, constitute provisions of the present document.

- References are either specific (identified by date of publication, edition number, version number, etc.) or non-specific.
- For a specific reference, subsequent revisions do not apply.
- For a non-specific reference, the latest version applies.
- A non-specific reference to an ETS shall also be taken to refer to later versions published as an EN with the same number.

- [1] ETR 028: "Radio Equipment and Systems (RES); Uncertainties in the measurement of mobile radio equipment characteristics".
- [2] ICAO Annex 10 Volume V (1996): "Aeronautical Radio Frequency Spectrum Utilization".
- [3] ITU-T Recommendation P.53: "Psophometer for use on telephone-type circuits".
- [4] ISO 7637 Road vehicles, Electrical disturbance by conducting and coupling (Parts 1 & 2).

---

# 3 Definitions and abbreviations

## 3.1 Definitions

For the purposes of the present document, the following terms and definitions apply:

Types of measurements:

**conducted measurements:** measurements which are made using a direct RF connection to the equipment under test

**radiated measurements:** measurements which involve the measurement of a radiated field

**aeronautical mobile service:** mobile service between aeronautical stations and aircraft stations, or between aircraft stations, in which survival craft stations may participate

Type of station:

**ground base station:** aeronautical station equipment, in the aeronautical mobile service, for use with an external antenna and intended for use at a fixed location

**mobile station:** radio equipment designed for permanent or temporary vehicle installation and operation, including provision for vehicle DC power supply, and connections for external antenna, PTT key, microphone, speaker and / or headphone



**portable station:** radio equipment with integral battery for independent hand-carried use. Provisions may be made for connections of an external antenna, PTT key, microphone, headphone and charger, but principally to be operated as a self contained unit

**hand held:** radio equipment with integral batteries, designed to be hand portable and operated hand held

**integral antenna equipment:** radio communications equipment with an antenna integrated into the equipment without the use of an external connector and considered to be part of the equipment. An integral antenna may be internal or external to the equipment. In equipment of this type, a 50  $\Omega$  RF connection point shall be provided for test purposes. A connection point for an AF modulating input and for AF output measurements shall also be provided

**non-integral antenna equipment:** radio communications equipment with a connector intended for connection to an antenna

## 3.2 Abbreviations

For the purposes of the present document, the following abbreviations apply:

ACARS	Aircraft Communications Addressing and Reporting System
AF	Audio Frequency
AGC	Automatic Gain Control
AM	Amplitude Modulation
dBc	dB relative to the carrier power
DSB	Double Side Band
I/P	Input
ICAO	International Civil Aviation Organization
IF	Intermediate Frequency
O/P	Output
ppm	parts per million
RF	Radio Frequency
rms	root mean square
SINAD	(Signal + Noise + Distortion)/(Noise + Distortion)
VSWR	Voltage Standing Wave Ratio

---

## 4 General requirements

8,33 kHz equipment shall be able to operate on all channels in the List of Assignable Frequencies defined in Appendix 2, chapter 4, Group F (subclause 4.1.8.1.2) of the ICAO Annex 10 Volume V [2].

The channel labelling used for 8,33 kHz channel spacing is based on a frequency-channel pairing in accordance with table 4.1 (bis) of ICAO Annex 10 Volume V [2] subclause 4.1.2.4.

25 kHz equipment shall be able to operate on the frequencies 118,0 MHz to 136,975 MHz in accordance with ICAO Annex 10 Volume V [2], Appendix to Chapter 4.

It shall not be possible to transmit while any frequency synthesizer used within the transmitter is out of lock.

It shall not be possible to transmit during channel switching operations.

### 4.1 Controls and indicators

The equipment shall have the following controls and indicators as a minimum:

- a visual indication that the device is switched on;
- a facility to disable the squelch for test purposes;
- a visual indication that the carrier is being produced.

The equipment shall also meet the following requirements:

- the user shall not have access to any control which, if wrongly set, might impair the technical characteristics of the equipment.

## 4.2 Class of emission and modulation characteristics

The equipment shall use Double Side Band (DSB) Amplitude Modulation (AM) full carrier, (6K80A3EJN for 25 kHz, 5K00A3EJN for 8,33 kHz), for speech and 13k0A2D for data. The equipment shall be designed to operate satisfactorily with a channel separation of 8,33 kHz or 25 kHz.

## 4.3 Warm up

After being switched on the equipment shall be operational within five seconds (ten seconds for hand held radios) and shall meet the requirements of the present document within one minute under normal test conditions (subclause 5.3).

If the equipment includes parts which require to be heated in order to operate correctly (e.g. crystal ovens) a warming-up period of 30 minutes of those parts shall be allowed.

---

# 5 Test conditions, power sources and ambient temperatures

## 5.1 Normal and extreme test conditions

Measurements shall be made under normal test conditions (subclause 5.3) and also, where stated, under extreme test conditions (subclauses 5.4.1 and 5.4.2 applied simultaneously).

## 5.2 Test power source

During testing, the equipment shall be supplied from a test power source capable of producing normal and extreme test voltages.

The internal impedance of the test power source shall be low enough for its effect on the test results to be negligible. For the purpose of testing the power source voltage shall be measured at the input terminals of the equipment.

During testing, the power source voltages shall be maintained within a tolerance of  $\pm 3$  % relative to the voltage level at the beginning of each test.

## 5.3 Normal test conditions

### 5.3.1 Normal temperature and humidity

The normal temperature and humidity conditions for tests shall be a combination of temperature and humidity within the following ranges:

- temperature: +15°C to +35°C;
- relative humidity: 20 % to 75 %.

When it is impracticable to carry out the tests under these conditions, a note to this effect, stating the ambient temperature and relative humidity during the tests, shall be added to the test report.

## 5.3.2 Normal power sources

### 5.3.2.1 Mains voltage and frequency

The normal test voltage for equipment to be connected to the mains shall be the nominal mains voltage.

For the purpose of this standard, the nominal voltage shall be the declared voltage or any of the declared voltages for which the equipment was designed.

The frequency of the test power source corresponding to the AC mains shall be between 49 Hz and 51 Hz.

### 5.3.2.2 Regulated lead-acid battery power sources used on vehicles

When the radio equipment is intended for operation from the usual types of regulated lead-acid battery power source used on vehicles, the normal test voltage shall be 1,1 times the nominal voltage of the battery (6 V, 12 V etc.).

### 5.3.2.3 Other power sources

For operation from other power sources or types of battery (primary or secondary), the normal test voltage shall be that declared by the equipment manufacturer.

## 5.4 Extreme test conditions

### 5.4.1 Extreme temperatures

For tests at extreme temperatures, measurements shall be made in accordance with subclause 5.5, at a lower temperature of -20°C and an upper temperature of +55°C. This test shall be performed at the nominal supply voltage as defined in subclause 5.3.2

### 5.4.2 Extreme values of test power sources

#### 5.4.2.1 Mains voltage

The extreme test voltages shall be between 207 V and 253 V. This test shall be performed at the normal temperature and humidity as defined in subclause 5.3.1.

The frequency of the test voltage shall be between 49 Hz and 51 Hz.

#### 5.4.2.2 Other power sources

For equipment using other power sources, or capable of being operated from a variety of power sources, the extreme test voltages shall be those agreed between the equipment manufacturer and the testing laboratory and shall be recorded in the test report. Equipment intended for vehicle installation shall meet the power supply requirements of ISO 7637 [4].

## 5.5 Performance test

For the purposes of the present document, the term "performance test" shall be taken to mean the following measurements and limits:

- for the transmitter:
  - frequency error:  
with the transmitter connected to a coaxial termination (subclause 6.2.1), the frequency error shall be as in subclause 7.2;
  - carrier power:  
with the transmitter connected to a coaxial termination (subclause 6.2.1), the transmitter shall be keyed without modulation and the output power shall be as defined in subclause 7.3;
  - modulation:  
with the transmitter connected to a coaxial termination (subclause 6.2.1), the transmitter shall be keyed. The modulation distortion shall be as in subclause 7.4.3;
- for the receiver:
  - sensitivity:  
with the AGC operative, a normal test signal (subclause 6.1.3) shall be applied to the receiver. The sensitivity shall be as defined in subclause 8.1.

## 5.6 Environmental tests

### 5.6.1 General

Environmental tests shall follow checking the protection of the transmitter (subclause 7.10) which follows the first application of the Performance test (subclause 5.5).

### 5.6.2 Procedure for tests at extreme temperatures

Before tests at the upper extreme temperature, the equipment shall be placed in the test chamber and left until thermal balance is attained. The equipment shall then be switched on for 30 minutes. The transmitter shall then be keyed for 1 minute in the transmit condition, after which the equipment shall meet the specified requirements. Transmitters shall be operated in the highest rated power transmit condition.

For tests at the lower extreme temperature, the equipment shall be left in the test chamber until thermal balance is attained, then switched to the standby or receive condition for 1 minute after which the equipment shall meet the specified requirements.

**NOTE:** It is assumed that equipment intended for off-set carrier operation will be installed in a building with facilities suitable to provide protection from temperature extremes, therefore extreme temperature tests need not be applied to such equipment.

## 5.6.3 Temperature tests

### 5.6.3.1 High temperature

- Place the equipment in a chamber and heat to 55°C ( $\pm 3^\circ\text{C}$ ) and allow to stabilize for 1 hour.
- Switch on the equipment.
- After 30 minutes carry out the performance test as detailed in subclause 5.5.
- Switch off the equipment and allow the chamber to cool to room temperature over a 1 hour period.
- Allow time for the equipment to stabilize to normal room temperature and humidity before carrying out the next test.

### 5.6.3.2 Low temperature

- Place the equipment in a chamber and cool to -20°C ( $\pm 3^\circ\text{C}$ ) for 2 hours.
- Switch on the equipment and maintain the chamber operating temperature at -20°C ( $\pm 3^\circ\text{C}$ ).
- After 1 minute carry out the performance test as detailed in subclause 5.5.
- Switch off the equipment and allow the chamber to rise to room temperature over a 1 hour period.
- Allow time for the equipment to stabilize to normal room temperature and for moisture to disperse before carrying out the next test.

---

## 6 General conditions of measurement

### 6.1 Receiver test signal arrangement

#### 6.1.1 Test signal sources

Test signal sources shall be connected to the receiver input in such a way that the impedance presented to the receiver input is 50  $\Omega$ , irrespective of whether one or more test signals are applied to the receiver simultaneously.

#### 6.1.2 Nominal frequency

The nominal frequency of the receiver is the carrier frequency of the selected channel.

#### 6.1.3 Normal test signal

The normal test signal shall be a Double Side Band signal with carrier, amplitude modulated with 1 kHz sinewave to a depth of 30 %.

#### 6.1.4 Squelch

Unless otherwise stated the receiver squelch facility shall be made inoperative for the duration of the tests.

### 6.1.5 Normal audio output power

The rated audio frequency output power is the value stated by the manufacturer to be the maximum power available at the output, for which all the requirements of the present document are met.

The audio frequency output power shall be maintained at 50 % of the rated output in the presence of a desired signal unless otherwise defined.

### 6.1.6 Audio AGC

When an audio AGC function is provided, this shall be disabled (where possible) unless otherwise stated.

## 6.2 Transmitter test signal arrangement

### 6.2.1 Coaxial termination

When tests are carried out with a coaxial termination, this shall be a non-reactive, non radiating 50  $\Omega$  load.

### 6.2.2 Signal sources

The modulating signals shall be applied to the transmitter through the modulating audio input.

### 6.2.3 Normal test signal

The normal test signal shall be a 1kHz sinewave at a level which produces a 30 % amplitude modulation depth, of the transmitter RF output, unless otherwise defined.

## 6.3 Test channels

Tests shall be carried out on three frequencies unless otherwise stated:

- 118 000 MHz;
- 127 500 MHz;
- 136 975 MHz.

---

# 7 Transmitter

All tests on the transmitter shall be carried out at the maximum rated output power (subclause 7.3.1) except where otherwise stated.

## 7.1 Protection of the transmitter

### 7.1.1 Definition

The protection of the transmitter represents the ability of the transmitter to be protected against malfunction due to faults in the antenna system. This shall be the first test applied to a transmitter.

### 7.1.2 Method of measurement

While the transmitter is transmitting at the rated output power, the antenna port shall first be short-circuited and then open-circuited, in each case for a period of 1 minute. This test shall be performed on the centre test frequency only.

### 7.1.3 Requirement

This test shall not result in any damage to the transmitter. After removal of the short-circuit and open-circuit conditions, the transmitter shall be able to operate normally when re-keyed.

## 7.2 Frequency error

### 7.2.1 Definition

The frequency error is the difference between the measured carrier frequency and its nominal value.

### 7.2.2 Method of measurement

The carrier frequency shall be measured in the absence of modulation, with the transmitter connected to a coaxial termination (subclause 6.2.1). Measurements shall be made under normal test conditions (subclause 5.3) and under extreme test conditions.

### 7.2.3 Limits

The frequency error shall be within the requirements of Table 1.

**Table 1**

Frequency Error	Normal Temperature +15°C to +35°C	Extreme Temperature -20°C to +55°C	Extended Temperature 0°C to 40°C
8,33 kHz Fixed Base	±1 ppm	N/A	±1 ppm
8,33 kHz Mobile/portable	±1 ppm	N/A	±1 ppm
8,33 kHz Hand held	±1 ppm	N/A	±1 ppm
25 kHz Fixed Base	±5 ppm	±10 ppm	N/A
25 kHz Mobile/portable	±10 ppm	±15 ppm	N/A
25 kHz Hand held	±10 ppm	±15 ppm	N/A
2-/3-carrier offset system	±5 ppm	N/A	±5 ppm
4-carrier offset system	±3,8 ppm	N/A	±3,8 ppm
5-carrier offset system	±0,3 ppm	N/A	±0,3 ppm

## 7.3 Carrier power

### 7.3.1 Definitions

The carrier power is the mean power delivered to the coaxial termination during transmission in the absence of modulation.

The requirements of this standard shall be met for all power output levels at which the transmitter is intended to operate into 50 Ω. For practical reasons measurements shall be performed only at the lowest and the highest power output level at which the transmitter is intended to operate.

### 7.3.2 Method of measurement

The transmitter shall be connected to a coaxial termination (subclause 6.2.1) and the output power delivered to this coaxial termination shall be measured at the output connector. The measurements shall be made under normal test conditions (subclause 5.3) and under extreme test conditions.

Measurements shall be made on the test channels (subclause 6.3).

### 7.3.3 Tolerances

#### 7.3.3.1 Normal test conditions

The carrier power measured under normal test conditions (subclause 5.3) with the output power adjusted to maximum, shall not vary by more than  $\pm 1,5$  dB from the rated maximum output power.

#### 7.3.3.2 Extreme test conditions

The carrier power measured under extreme test conditions (subclause 5.4) with the output adjusted to maximum rated power, shall not vary by more than +1,5 dB and -3 dB from the rated maximum output power.

## 7.4 Amplitude modulation characteristic

### 7.4.1 Modulation depth (speech)

#### 7.4.1.1 Definitions

##### **Amplitude modulation depth:**

The amplitude modulation depth is the fractional ratio, expressed as a percentage, of the difference and the sum of the numerical values of the largest and smallest amplitudes encountered in one cycle of the modulating waveform

##### **Limiting threshold**

The limiting threshold is defined as the minimum audio input level required to produce the manufacturers declared modulation depth for the equipment (85 % minimum at 1 kHz).

#### 7.4.1.2 Method of measurement

The normal 1 kHz test signal shall be applied to the modulation input of the transmitter. The test signal level shall then be set at a level 3 dB above the limiting threshold.

The modulation depth shall be measured at the output of the transmitter connected to a coaxial termination (subclause 6.2.1), by means of a modulation analyser.

#### 7.4.1.3 Limits

The amplitude modulation depth shall be at least 85 % under normal temperature conditions and 85 %  $\pm 5$  % for extreme temperature measurements.

#### 7.4.1.4 Modulation depth (data mode)

#### 7.4.1.5 Method of measurement

The normal 1 kHz test signal shall be applied to the data modulation input of the transmitter. The test signal level shall then be adjusted to produce 85 % modulation depth.

The modulation depth shall be measured at the output of the transmitter connected to a coaxial termination (subclause 6.2.1), by means of a modulation analyser.

#### 7.4.1.6 Limits

The amplitude modulation depth shall be 85 % under normal temperature conditions for an input signal of 0 dBm at the data input.



## 7.4.2 Modulation compression (speech mode)

### 7.4.2.1 Definition

Modulation compression is the reduction of the modulation sensitivity at input signal levels above the limiting threshold determined in subclause 7.4.1.

### 7.4.2.2 Method of measurement

The normal test signal of 1 kHz shall be applied to the audio input of the transmitter.

The modulation depth shall be measured at the output of the transmitter connected to a coaxial termination by means of a modulation analyser capable of measuring the maximum amplitude modulation depth. Adjust the audio level applied to the modulation input to produce a modulation level of 30 %. Set the audio signal to produce modulation levels of 10 % and at the threshold that produces 85 %.

Confirm that when the level is varied between the values in Table 2, the corresponding modulation depth changes are achieved within the stated tolerances.

With the audio input level set at the threshold that produces 85 % modulation, increase the level by 20 dB and record the maximum usable modulation depth.

### 7.4.2.3 Limits

The modulation shall be linear up to 85 % within  $\pm 2$  dB.

The maximum usable modulation depth shall not exceed 95 %.

**Table 2**

Level Increase	Modulation Change	Level Tolerance
10 dB	10 % to 30 %	$\pm 2$ dB
9 dB	30 % to 85 %	+1 dB / -2 dB

## 7.4.3 Amplitude modulation distortion

### 7.4.3.1 Definition

The amplitude modulation distortion is the ratio of the total rms voltage of all the harmonics of the modulated waveform to the total rms voltage.

### 7.4.3.2 Method of measurement

The normal test signal of 1 kHz set at a level 3 dB above the limiting threshold determined in subclause 7.4.1 shall be applied to the modulation input of the transmitter.

The modulation distortion shall be measured at the output of the transmitter connected to a coaxial termination (subclause 6.2.1), by means of a distortion analyser.

For equipment designed for ACARS operation, the test shall be repeated for an input signal of 0 dBm as determined in subclause 7.4.1.3.

### 7.4.3.3 Limits

The amplitude modulation distortion shall be less than 10 %.

## 7.4.4 Audio frequency response

### 7.4.4.1 Definition

The audio frequency response expresses the ability of the transmitter to operate without excessive degradation of its frequency response as a function of the modulation frequency.

### 7.4.4.2 Method of measurement

The audio frequency response shall be measured on the mid band Test Channel only.

The Normal test signal (subclause 6.2.3) shall be modulated at 60 %.

The modulation frequency shall be varied between 300 Hz and 5 kHz, with the level of the audio input test signal kept constant.

Where a data input is provided the test shall be made in both modes.

### 7.4.4.3 Limits 8,33 kHz channel spacing

The ratio of the maximum and minimum modulation depth as measured over the AF modulating frequency range of 350 Hz to 2,5 kHz shall be less than +2 dB and -4 dB (referred to 1 kHz).

At 3,2 kHz the ratio shall be at least -25 dB referred to 1 kHz.

### 7.4.4.4 Limits 25 kHz channel spacing

The ratio of the maximum and minimum modulation depth as measured over the AF modulating frequency range of 300 Hz to 3,4 kHz shall be less than +2 dB and -4 dB (referred to 1 kHz). The necessary AF test range for mobile, portable and handheld equipment can be reduced to 350 Hz to 2,5 kHz.

At 5 kHz the ratio shall be at least -25 dB referred to 1 kHz.

For data operation, the ratio of the maximum and minimum modulation depth as measured over the AF modulating frequency range of 1,2 kHz to 2,4 kHz shall be less than  $\pm 3$  dB.

## 7.4.5 Group delay variation (data mode only)

### 7.4.5.1 Definition

Audio filters do not provide a uniform transmission speed for all frequencies. Consequently, a phase difference can occur between frequencies within the passband. Group delay (or envelope delay) is proportional to the change in slope of the phase shift response versus frequency curve.

### 7.4.5.2 Transmitter method of measurement

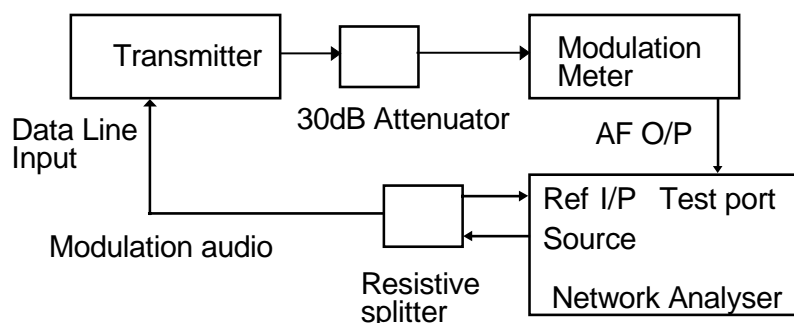

**NOTE:**

- a) The output of the network analyser is connected to a resistive splitter to give two audio signal outputs.
- b) One signal is connected to the network analyser's reference input, whilst the second feeds the transmitter with a modulation signal to be applied to the data input port.
- c) The modulation meter shall be set to wideband operation to prevent delay variation occurring in the test equipment.
- d) The source level is adjusted at the network analyser to produce a 85 % modulated signal at 1 kHz.
- e) The modulation meter's audio output is fed into the test port on the analyser and the network analyser adjusted to sweep from 100 Hz to 3 kHz, with a 30 Hz resolution bandwidth.
- f) Set the analyser's markers to show the group delay variation between 1,2 kHz and 2,4 kHz.
- g) The group delay variation shall be measured on the mid band test frequency only.

**Figure 1: Transmitter Group Delay diagram**

### 7.4.5.3 Limits

The group delay variation between 1,2 kHz and 2,4 kHz shall be < 60 us.

## 7.5 Adjacent channel power

### 7.5.1 Definition

The adjacent channel power is that part of the total power output of a transmitter under defined conditions of modulation, which falls within a specified passband centred on the nominal frequency of either of the adjacent channels. This power is the sum of the mean power produced by the modulation, hum and noise of the transmitter.

### 7.5.2 Measurement

The adjacent channel power shall be measured with a power measuring receiver, or an equivalent analyser here referred to as the "measurement receiver", conforming to annex B:

- a) the transmitter shall be operated at the maximum carrier power determined in subclause 7.3 under normal test conditions. The output of the transmitter shall be linked to the input of the " measurement receiver " by a connecting device such that the impedance presented to the transmitter is 50  $\Omega$  and the level at the "measurement receiver" input is appropriate;
- b) the transmitter shall be modulated with a signal at 1 kHz for 8,33 kHz and 25 kHz channels at a level required to produce a modulation depth of 85 %;
- c) with the transmitter modulated, the tuning of the "measurement receiver" shall be adjusted so that a maximum response is obtained. This is the 0 dB response point. The "measurement receiver" attenuator setting and the reading of the meter shall be recorded;
- d) the tuning of the "measurement receiver" shall be adjusted away from the carrier so that the "receiver" -6 dB response nearest to the transmitter carrier frequency is located at a displacement from the nominal carrier frequency of 4,83 kHz (8,33 kHz channel spacing) or 17 kHz (25 kHz channel spacing);
- e) the "measurement receiver" variable attenuator shall be adjusted to obtain the same meter reading as in step c) or a known relation to it;
- f) the ratio of adjacent channel power to carrier power is the difference between the attenuator settings in steps c) and e), corrected for any differences in the reading of the meter;
- g) the measurement shall be repeated with the "measurement receiver" tuned to the other side of the carrier.

### 7.5.3 Limits

The adjacent channel power shall not exceed the following values below the carrier power of the transmitter:

- 8,33 kHz Channel spacing: 50 dB;
- 25 kHz Channel spacing: 60 dB.

## 7.6 Broadband noise measurement

### 7.6.1 Definition

The broadband noise test determines the phase noise generated by the transmitter, (when keyed), between the adjacent channel and within the spurious emission exclusion band. It is necessary to minimize the effects of this noise in order to prevent desensitization of receivers operating on frequencies close to the transmitter.

## 7.6.2 Method of measurement

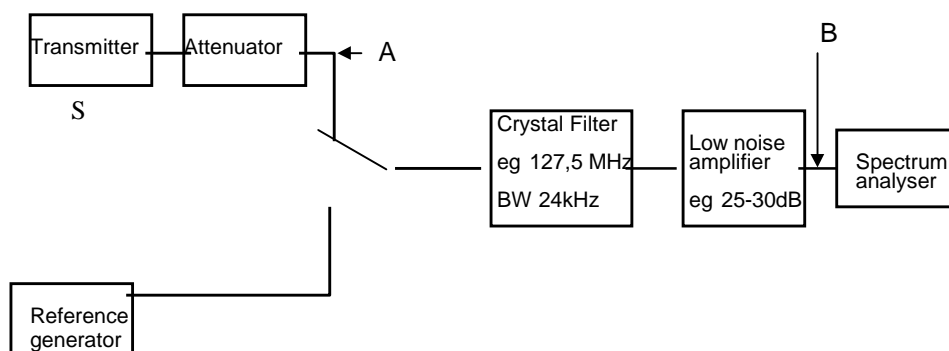

$F_c$  = filter frequency  $\pm$  300/500kHz

NOTE 1: When using crystal filters, the input power shall not exceed 0 dBm. The power attenuator should be chosen such that the level appearing at the filter input never exceeds this limit.

A RF fuse may be placed at the input to the filter in order to provide additional protection.

NOTE 2: For output powers of > 25 W the attenuator should provide 50 dB of attenuation in order to protect the crystal filter.

NOTE 3:

- Connect equipment as shown in Figure 2.
- Initially connect the spectrum analyser to the 50 dB attenuator output (point A). Set the transmitter to produce an unmodulated carrier at the crystal filter frequency. Using a 50 kHz span and a 1 kHz bandwidth, note the output reference power ( $P_r$ ).
- Reconnect the analyser to the amplifier output (point B).
- Adjust the transmitter frequency to 300 kHz above the crystal filter frequency. Key the transmitter and apply modulation at 1 kHz at a level to give 85 % modulation depth. Monitor the noise level on the spectrum analyser. Use the analysers averaging function to find the mean level within the crystal filter bandwidth. Note this level as ( $P_m$ ).
- De-key the transmitter and apply an unmodulated signal from the reference generator at the crystal filter frequency. Increase the RF level until it is the same amplitude as the noise level noted above ( $P_m$ ). Record this level as  $P_{mref}$ .
- The wide band noise at 300 kHz offset is then determined from the following formulae:  

$$WB\ noise = P_{mref} + P_r + BW\ correction \quad (dBc/Hz)$$
 where BW correction for 1 kHz = 30 dB.
- Adjust the transmitter frequency to 300 kHz below the crystal filter frequency and  $\pm$ 500 kHz offset from the filter frequency and repeat the test for each transmitter frequency.

**Figure 2: Broadband noise measurement**

## 7.6.3 Limit

The broadband noise limit shall be: < -130 dBc/Hz.

## 7.7 Conducted spurious emissions

### 7.7.1 Definition

Conducted spurious emissions are RF emissions appearing at the RF output port on a frequency or frequencies which are outside the necessary bandwidth and the level of which may be reduced without affecting the corresponding transmission of information. Conducted spurious emissions include harmonic emissions, parasitic emissions, intermodulation products and frequency conversion products, but exclude out of band emissions.

### 7.7.2 Method of measurement

- Conducted spurious emissions shall be measured with the unmodulated transmitter connected to the coaxial termination (subclause 6.2.1) and operating on the centre test frequency (subclause 6.3).
- The measurements shall be made over a range from 9 kHz to 4 GHz, excluding the channel on which the transmitter is operating and separated from the centre frequency of the emission by  $\pm 1$  MHz.
- The measurements for each spurious emission shall be made using a tuned radio measuring instrument or a spectrum analyser.
- The measurements shall be repeated with the transmitter in standby mode.

### 7.7.3 Limits

Table 3

Environmental phenomena	Frequency range	Units	Test limits, Tx Standby	Test limits Tx active mode	Reference bandwidth
Spurious conducted RF Emissions	9 kHz to 150 kHz	dBm	-57 (2 nW)	-46 dBm	B = 1 kHz
Spurious conducted RF Emissions	> 150 kHz to 30 MHz	dBm	-57 (2 nW)	-46 dBm	B = 9 kHz to 10 kHz
Spurious conducted RF Emissions	> 30 MHz to 1 GHz	dBm	-57 (2 nW)	-36 dBm for harmonics, -46 dBm for non-harmonic spurious	B = 10 kHz (notes 1 and 2)
Spurious conducted RF Emissions	> 1 GHz to 4 GHz	dBm	-47 (20 nW)	-30 dBm for harmonics -40 dBm for non-harmonic spurious	B = 10 kHz

NOTE 1: For transmitters with an RF output above 50 W a limit of -80dBc will be applied for harmonically related spurious.

NOTE 2: An exclusion band of  $\pm 1$  MHz about the carrier shall be used in active transmit mode.

NOTE: Cabinet radiation measurements do not appear in the present document. This aspect is replaced by applying the radiated emission test contained in the ETSI EMC standard for VHF ground based aeronautical communications equipment. The combination of applying the conducted spurious measurement above, and radiated measurements up to and beyond the 7<sup>th</sup> harmonic of the highest selectable frequency is considered sufficient to provide confidence that undesired emissions are adequately contained.

## 7.8 Intermodulation attenuation

### 7.8.1 Definition

Intermodulation attenuation is the capability of a transmitter to avoid the generation of signals in the non-linear elements caused by the presence of the carrier and an interfering signal entering the transmitter via the antenna.

It is specified as the ratio, in dB, of the power level of the third order intermodulation product to the carrier power level.

### 7.8.2 Method of measurement

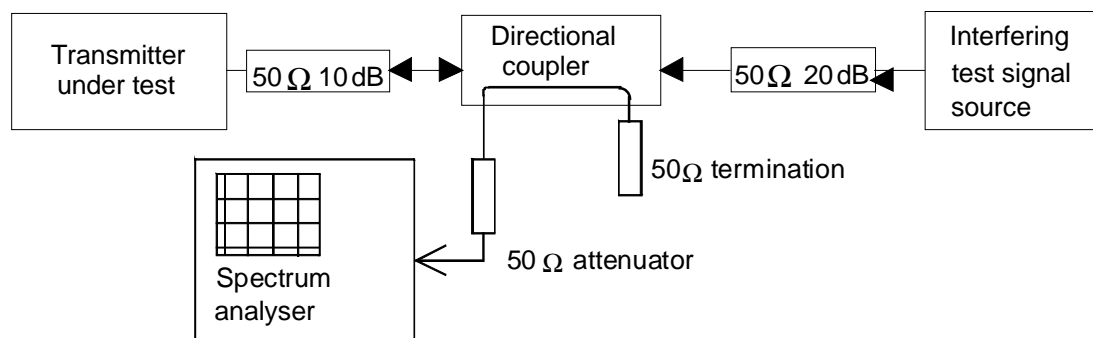

**NOTE:**

- a) The measurement arrangement shown in Figure 3 shall be used.
- b) The transmitter shall be connected to a 50 Ω, 10 dB power attenuator and via a directional coupler to a spectrum analyser. An additional attenuator may be required between the directional coupler and the spectrum analyser to avoid overloading the spectrum analyser.
- c) In order to reduce the influence of mismatch errors it is important that the 10 dB power attenuator is coupled to the transmitter under test with the shortest possible connection.
- d) The interfering test signal source is connected to the other end of the directional coupler via a 50 Ω, 20 dB power attenuator.
- e) The interfering signal source may be either a transmitter providing the same power output as the transmitter under test and be of a similar type or a signal generator and a linear power amplifier capable of delivering the same output power as the transmitter under test.
- f) The directional coupler shall have an insertion loss of less than 1 dB, a sufficient bandwidth and a directivity of more than 20 dB.
- g) The transmitter under test and the test signal source shall be physically separated in such a way that the measurement is not influenced by direct radiation.
- h) The transmitter under test shall be unmodulated and the spectrum analyser adjusted to give a maximum indication with a frequency scan width of 500 kHz.
- i) The interfering test signal source shall be unmodulated and the frequency shall be within 150 kHz to 200 kHz above the frequency of the transmitter under test.
- j) The frequency shall be chosen in such a way that the intermodulation components to be measured do not coincide with other spurious components.
- k) The power output of the interfering test signal source shall be adjusted to the carrier power level of the transmitter under test by the use of a power meter.
- l) The intermodulation component shall be measured by direct observation on the spectrum analyser and the ratio of the largest third order intermodulation component to the carrier recorded.
- m) This measurement shall be repeated with the interfering test signal source at a frequency within 150 kHz to 200 kHz below the frequency of the transmitter under test.

**Figure 3: Measurement arrangement**

### 7.8.3 Limits

The intermodulation protection ratio shall be at least 40 dB.

## 7.9 RF power attack time and release time

### 7.9.1 Definitions

The transmitter power attack time ( $t_a$ ) is the time which elapses between:

- $t_{on L}$ : defined by the condition when the transmitter output power, measured at the antenna terminal, exceeds -20 dBc;
- $t_{on H}$ : defined by the condition when the transmitter output power has reached -1,5 dBc.

The transmitter release time ( $t_r$ ) is the time which elapses between:

- $t_{off H}$ : defined by the condition when the transmitter output power falls below -1,5 dBc;
- $t_{off L}$ : defined by the condition when the transmitter output power has reached -20 dBc.

The measured value of  $t_a$  and  $t_r$  are respectively  $t_{am}$  (transmitter attack measurement) and  $t_{rm}$ ; (transmitter release measurement), the limits are respectively  $t_{al}$  and  $t_{rl}$ .

### 7.9.2 Method of measurement

#### 7.9.2.1 Attack time

The following method of measurement shall be used:

- a) the transmitter is connected to a RF detector via a matched test load. The attenuation of the test load shall be chosen in such a way that the input of the RF detector is protected against overload and the detector operates as soon as the transmitter is keyed:
  - a dual trace storage oscilloscope (or a transient recorder) records the amplitude transient from the detector on a logarithmic scale;
  - a trigger device may be required to ensure that the start of the sweep of the oscilloscope timebase occurs the instant at which the "transmitter  $t_{on L}$ " function is initiated;
  - a spectrum analyser can also be used;
- b) the traces of the oscilloscope shall be calibrated in power (y-axis) and in time (x-axis), using the signal generator;
- c) the transmitter attack time shall be measured by direct reading on the oscilloscope while the transmitter is unmodulated.



### 7.9.2.2 Release time

The following method of measurement shall be used:

- a) the transmitter is connected to a RF detector via a matched test load. The attenuation of the test load shall be chosen in such a way that the input of the RF detector is protected against overload and the detector operates as soon as the transmitter is keyed:
  - a dual trace storage oscilloscope (or a transient recorder) records the amplitude transient from the detector on a logarithmic scale;
  - a trigger device may be required to ensure that the start of the sweep of the oscilloscope timebase occurs the instant at which the "transmitter  $t_{\text{off H}}$ " function is de-activated;
  - a spectrum analyser can also be used;
- b) the traces of the oscilloscope shall be calibrated in power (y-axis) and in time (x-axis), using the signal generator;
- c) the transmitter release time shall be measured by direct reading on the oscilloscope while the transmitter is unmodulated.

### 7.9.3 Limits

- $t_{\text{al}}$  shall be <20 ms;
- $t_{\text{rl}}$  shall be <10 ms. (<5ms for equipment's operating in data mode).

The keying time (the period from the initial keying signal to the point when the transmitter produces 90 % of the transmit power) shall be <50 ms.

## 7.10 Keying Transient frequency behaviour of the transmitter

### 7.10.1 Definitions

The transient frequency behaviour of the transmitter due to the wide-band spectral response caused by repeated switching of the keyline.

## 7.10.2 Method of measurement

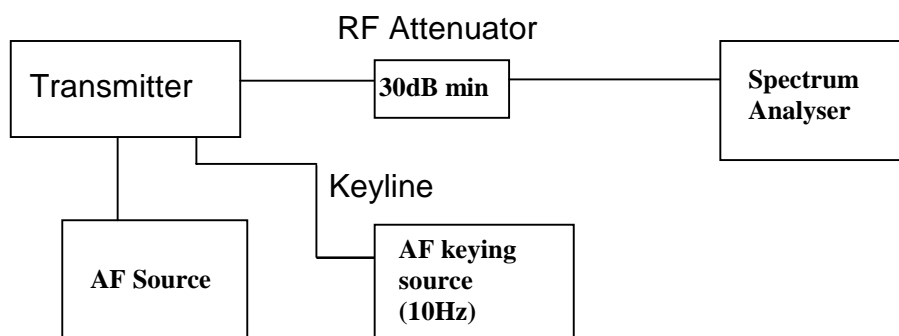

### NOTE:

- a) The transmitter shall be connected via a 50  $\Omega$  power attenuator, capable of reducing the RF power to a safe level for the spectrum analyser.
- b) The transmitter shall be set to 118 MHz and be modulated by a 1 kHz tone to produce a modulation depth of 85 %.
- c) The analyser shall be adjusted to the nominal frequency of the transmitter and the span adjusted to 100 kHz with a 1 kHz bandwidth.
- d) The transmitter shall be keyed and the spectrum analyser settings adjusted to display a centre frequency response at the reference level (using maximum hold function), with at least 60 dB dynamic range.
- e) The transmitter Keyline shall then be controlled by a suitable switching signal which shall allow the transmitter to be keyed at a rate of at least 5 Hz.
- f) The analyser shall be set to maximum hold and the keyline switched at the above rate for at least 2 minutes.
- g) The analyser display shall be recorded.
- h) Repeat for all test channels (subclause 6.3).

**Figure 4: Measurement arrangement**

## 7.10.3 Limits

The transients shall be at least 30 dB below the reference level at frequencies separated from the carrier by more than 10 kHz.

# 8 Receiver

## 8.1 Sensitivity

### 8.1.1 Definition

The sensitivity of the receiver is the level of the signal at the nominal frequency of the receiver which, when applied to the receiver input with normal test modulation (subclause 6.1.3), produces:

- in all cases, an audio frequency output power not less than 50 % of the rated output power (subclause 6.1.5); and
- a SINAD ratio of 12 dB, measured at the receiver output using a psophometric telephone filtering network as described in ITU-T Recommendation P.53 [3].

## 8.1.2 Method of measurement

- a) A normal test signal (subclause 6.1.3) at a carrier frequency equal to the nominal frequency of the receiver shall be applied to the receiver input. An audio frequency load and a measuring instrument for measuring the SINAD ratio (through a psophometric network) shall be connected to the receiver output terminals.
- b) The level of the test signal shall be adjusted until a SINAD ratio of 12 dB is obtained, using the psophometric network and with the receiver's audio power control adjusted to produce 50 % of the rated output power. Under these conditions, the level of the test signal at the input is the value of the maximum sensitivity.
- c) The measurements shall be made under normal test conditions (subclause 5.3) and under extreme test conditions.
- d) A receiver output power variation of  $\pm 3$  dB relative to 50 % of the rated output power may be allowed for sensitivity measurements under extreme test conditions. The measurements shall be performed at all test channels (subclause 6.3).

## 8.1.3 Limits

The maximum sensitivity shall not exceed -101 dBm under normal test conditions and -95 dBm under extreme test conditions.

## 8.2 Harmonic distortion

### 8.2.1 Definition

The harmonic distortion at the receiver output is defined as the ratio, expressed as a percentage, of the total rms voltage of all the harmonic components of the modulation audio frequency to the total rms voltage of the signal delivered by the receiver.

### 8.2.2 Method of measurement

- a) The normal test signal (subclause 6.1.3) shall be applied at the centre test frequency (equal to the nominal frequency of the receiver), at levels of -53 dBm and -13 dBm. The signal shall be applied in succession to the receiver input under the normal test conditions specified in subclause 5.3.
- b) AF AGC shall be switched off where possible.
- c) The audio distortion shall be measured for test signals producing 30 % (normal) and 90 % modulation levels.
- d) The audio input to the distortion meter shall be adjusted to produce 50 % of the rated output power for each test.

### 8.2.3 Limits

The harmonic distortion shall not exceed 5 % at 30 % modulation depth and 10 % at 90 % modulation depth.

## 8.3 Audio frequency response

### 8.3.1 Definition

The audio frequency response expresses the ability of the receiver to operate without excessive degradation of its frequency response as a function of the audio frequency.

### 8.3.2 Method of measurement

The audio frequency response shall be measured on the mid band test frequency only.

- a) A test signal (subclause 6.1) at a level of -53 dBm at a carrier frequency equal to the nominal frequency of the receiver shall be applied to the receiver input under normal test conditions specified in subclause 5.3.
- b) AF AGC shall be switched off.
- c) The audio frequency shall then be varied between 300 Hz and 3,4 kHz, with the level of the test signal being kept constant and equal to the value specified above.
- d) Where a separate data output exists the response shall also be measured at this port.

### 8.3.3 Limits

The audio output level shall not vary by more than +2 dB and -4 dB within the frequency range of 350 Hz to 2,5 kHz for 8,33 kHz channel spaced equipment and 300 Hz to 3,4 kHz for 25 kHz channel spaced equipment. The necessary AF test range for mobile portable and handheld 25 kHz channel spaced equipment can be reduced to 350 Hz to 3 kHz.

### 8.3.4 Limit for ACARS Operation

The audio output level shall not vary by more than +2 dB and -4 dB within the frequency range of 1,2 kHz and 2,4 kHz.

## 8.4 Audio noise

### 8.4.1 Definition

The audio noise is defined as the ratio, in dB, of the audio-frequency power of the noise to the audio-frequency power produced by the normal test signal (subclause 6.1) applied to the receiver input weighted according ITU-T Recommendation P.53 [3].

### 8.4.2 Method of measurement

- a) A test signal (subclause 6.1) at a level of -13 dBm at a carrier frequency equal to the nominal frequency of the receiver shall be applied to the receiver input under normal test conditions specified in subclause 5.3. Modulation depth shall be set at 90 %.
- b) The audio output level shall be set to the rated output power for the output under test (loudspeaker, headset, line output). A resistive load modelling the normal audio output load shall be connected.
- c) The output signal including noise ( $S + N$ ) shall be measured by a rms voltmeter and recorded.
- d) Then the modulation of the test signal shall be switched off and the audio-frequency output level ( $N$ ) shall be measured.

The measurements shall be made using psophometric filtering network, ITU-T Recommendation P.53 [3].

### 8.4.3 Limits

The ratio  $(S + N)/N$  shall be better than 40 dB.

## 8.5 Effective Acceptance Bandwidth

### 8.5.1 Definition

The effective acceptance bandwidth is the frequency range over which an applied signal shall not be rejected by the receiver. In 25 kHz spaced channels this bandwidth allows the reception of offset carriers.

### 8.5.2 Method of Measurement

A test signal ( subclause 6.1.3) at a RF. level necessary to achieve a 12 dB SINAD via a psophometric filter, shall be applied to the receiver input under normal test conditions (subclause 5.3). The RF signal shall then be increased by 6 dB.

The test signal frequency shall be varied  $\pm 8,5$  kHz for 25 kHz receivers and  $\pm 2,8$  kHz for 8,33 kHz receivers from the nominal carrier frequency of the receiver with the test signal amplitude being kept constant and equal to the value specified above.

### 8.5.3 Limits

The SINAD ratio shall be  $>12$  dB. The test signal frequency shall be at least  $\pm 8,5$  kHz for 25 kHz receivers and  $\pm 2,8$  kHz for 8,33 kHz receivers from the nominal carrier frequency.

NOTE: For receivers intended for use with 3, 4 and 5 offset channels a 6 dB point of  $\pm 11$  kHz is recommended.

## 8.6 Adjacent channel rejection

### 8.6.1 Definition

The adjacent channel rejection is a measure of the capability of the receiver to receive a wanted modulated signal without exceeding a given degradation due to the presence of an unwanted modulated signal which differs in frequency from the wanted signal by 8,33 kHz or 25 kHz as appropriate.

### 8.6.2 Method of measurement

- a) The two input signals from signal generators G1 and G2 shall be applied to the receiver input via a combining network. An audio analyser shall be connected to the receiver output terminals via a psophometric filter.
- b) With the output of G2 switched off, the wanted test signal from G1 at the receive frequency, shall be set to produce a modulation depth of 60 % at 1 kHz.
- c) Adjust the level of G1 to achieve a SINAD of 12 dB at the receiver output terminals.
  - a) This shall be recorded as Level 1.
  - d) Repeat the measurement but this time switch off G1 and adjust G2, modulated 60 % at 1kHz, to achieve a SINAD of 12 dB at the receiver output terminals.
    - This shall be recorded as Level 2.
  - e) Switch on generator G1. Set G2 to a frequency of one channel separation above the nominal frequency of the receiver and apply modulation at 400 Hz with 60 % modulation depth.
  - f) The amplitude of the unwanted signal shall be adjusted until the SINAD ratio at the output of the receiver is reduced to 6 dB.
    - Record this level as Level 3.
  - g) The upper adjacent channel rejection is the difference between Level 3 and Level 2.

- h) The measurement shall be repeated with the unwanted signal (G2) on the channel below that of the wanted signal.
- i) For the upper and lower adjacent channel measurements the minimum difference shall be recorded as the adjacent channel rejection.

### 8.6.3 Limits

The adjacent channel rejection shall be greater than 60 dB.

## 8.7 Spurious response rejection

Spurious responses may occur at all frequencies throughout the frequency spectrum and the requirements of the present document shall be met for all frequencies. However, for practical reasons the measurements for type testing shall be performed as specified in the present document. More specifically, this method of measurement is not intended to capture all spurious responses but selects those that have a high probability of being present. However, in a limited frequency range close to the nominal frequency of the receiver, it has been considered impossible to determine the probability of a spurious responses and therefore a search shall be performed over this limited frequency range. This method provides a high degree of confidence that the equipment also meets the requirements at frequencies not being measured.

### 8.7.1 Definition

The spurious response rejection is a measure of the capability of the receiver to discriminate between the wanted modulated signal at the nominal frequency and an unwanted signal at any other frequency at which a response is obtained.

### 8.7.2 Introduction to the method of measurement

To determine the frequencies at which spurious responses can occur the following calculations shall be made:

- a) calculation of the "limited frequency range":
  - the limited frequency range is defined as the frequency of the local oscillator signal ( $f_{LO}$ ) applied to the first mixer of the receiver plus or minus the sum of the intermediate frequencies ( $f_{i1}...f_{in}$ ) and a half of the maximum frequency range ( $fr_m$ ) of the receiver.
  - hence the frequency  $f_L$  of the limited frequency range is:

$$f_{LO} - \sum_{j=1..n} f_{ij} - fr_m/2 \leq f_L \leq f_{LO} + \sum_{j=1..n} f_{ij} - fr_m/2$$

- b) calculation of frequencies outside the limited frequency range:
  - the frequencies outside the limited frequency range determined in a) are equal to the harmonics of the frequency of the local oscillator signal ( $f_{LO}$ ) applied to the first mixer of the receiver plus or minus the first intermediate frequency ( $f_{i1}$ ) of the receiver;
  - hence the frequencies of these spurious responses are  $nf_{LO} \pm f_{i1}$ , where n is an integer greater than or equal to 2;
  - the measurement of the first image response of the receiver shall initially be made to verify the calculation of spurious response frequencies.

For calculations a) and b), the manufacturer shall state the frequency of the receiver, the frequency of the local oscillator signal ( $f_{LO}$ ) applied to the first mixer of the receiver, the intermediate frequencies ( $f_{i1}$ ,  $f_{i2}$  etc.), and the maximum frequency range ( $fr_m$ ) of the receiver.

### 8.7.3 Method of search of the limited frequency range

- a) The normal test signal shall be applied (subclause 6.1.3).
- b) The test signal shall be adjusted to a level corresponding to a SINAD ratio of 12 dB via a psophometric filter and recorded as the reference level.
- c) The input level of the test signal shall then be adjusted to 80dB above the reference level.
- d) The frequency shall be varied continuously over the limited frequency range determined in subclause 8.7.2 a) and over the frequencies outside the frequency range in accordance with the calculations in subclause 8.7.2 b).
- e) The frequency of any spurious responses detected during the search shall be recorded for the use in the measurement described in the following subclause.

### 8.7.4 Method of measurement

- a) The test signal from a signal generator shall be applied to the receiver input. An rms voltmeter shall be connected to the receiver output via a psophometric filter.
- b) The test signal shall be a normal test signal (subclause 6.1.3) at the nominal frequency of the receiver.
- c) The RF signal level shall be adjusted to produce a SINAD ratio of 12 dB, and the RF level recorded as the reference level.
- d) The signal generator shall then be tuned to a spurious response frequency detected according to subclause 8.7.3 and modulated with normal test modulation.
- e) The level of the RF signal is increased until the receiver output signal produces an SINAD ratio of 12 dB.
- f) This RF signal level shall be recorded as the unwanted signal level.
- g) The spurious response rejection ratio is the ratio in dB of the unwanted signal level to the reference level.
- h) This measurement shall be made for each frequency detected according to subclause 8.7.3.

### 8.7.5 Limit

At any frequency separated from the nominal frequency of the receiver by more than two channels, the spurious response rejection ratio shall be not less than 70 dB.

## 8.8 Intermodulation response rejection

### 8.8.1 Definition

The intermodulation response rejection is the capability of a receiver to receive a wanted modulated signal at the nominal frequency, without exceeding a given degradation due to the presence of two or more unwanted signals with a specific frequency relationship to the wanted signal frequency.

## 8.8.2 Method of measurement

- a) The wanted signal from signal generator A, at the nominal frequency and producing a normal test signal (subclause 6.1.3) shall be applied to the input of the receiver via a combining network.
- b) The unwanted signal from signal generator B, at the frequency 100 kHz above the nominal frequency of the receiver and without modulation shall be applied to the receiver via the second input of the combining network.
- c) An rms voltmeter shall be connected to the receiver output via a psophometric filter.
- d) With the unwanted signal switched off, the level of the wanted signal shall be set to -53 dBm and the receiver volume control adjusted to obtain approximately 50 % of the rated audio output power.
- e) The level of the wanted signal shall be reduced until a 12 dB SINAD ratio is obtained.
- f) The level of the wanted signal under these conditions shall be recorded (x).
- g) The frequency of the wanted signal shall then be changed to a frequency of 200 kHz above the nominal frequency of the receiver. This signal now constitutes the second unwanted signal.
- h) The level of the two unwanted signals shall be kept equal and increased in level until a 12 dB SINAD ratio is again obtained. If necessary the frequency of either signal shall be varied slightly to obtain the maximum value of this ratio, their levels being re-adjusted to restore the 12 dB SINAD ratio.
- i) The level of the two signals under these conditions shall be recorded (y).
- j) The ratio, in dB, of the levels of the unwanted signals (y) to that recorded for the wanted signal (x) is the intermodulation response rejection ratio.
- k) These measurements shall be made on both sides of the nominal frequency.

## 8.8.3 Limit

The intermodulation response rejection ratio shall be:

- >70 dB for 8,33 kHz and 25 kHz channel spaced equipment designed for fixed base station operation;
- >64 dB for mobile, portable and handheld 8,33 kHz and 25 kHz channel spaced equipment.

## 8.9 Blocking or desensitization

### 8.9.1 Definition

Blocking is a measure of the capability of the receiver to receive a wanted modulated signal without exceeding a given degradation due to the presence of an unwanted input signal at any frequencies other than those of the spurious responses or the adjacent channels.



## 8.9.2 Method of measurement

- a) Two input signals shall be applied to the receiver via a combining network. An rms voltmeter shall be connected to the receiver output terminals via a psophometric filter.
- b) The wanted normal test signal (subclause 6.1.3), at the nominal frequency, and at the sensitivity level (subclause 8.1) of the receiver shall be applied to the receiver input connector via one of the inputs of the combining network.
- c) Where available, the receiver volume control shall be adjusted to give at least 50 % of the rated output power (subclause 6.1.5).
- d) The unwanted signal shall be unmodulated and the frequency shall be +1 MHz and -1 MHz relative to the nominal frequency of the receiver. The input level of the unwanted signal shall be adjusted until:
  - 1) the audio output level of the wanted signal is reduced by 3 dB; or
  - 2) the SINAD ratio, psophometrically weighted, at the receiver output is reduced to 6 dB.
- e) The measure of the blocking or desensitization is the ratio in dB of the level of the unwanted test signal to the level of the wanted test signal at the receiver input for which the specified reduction in audio output level or SINAD ratio occurs.

## 8.9.3 Limit

The blocking ratio, for any frequency within the specified ranges, shall not be less than 80 dB for base station equipment and not be less than 70 dB for mobile, portable and handheld equipment.

## 8.10 Conducted spurious emissions

### 8.10.1 Definition

Conducted spurious emissions from the receiver are signals at any frequency, emitted from the antenna port. The level of spurious radiation shall be measured by their power level at the antenna connector.

### 8.10.2 Method of measuring the power level

Spurious radiation shall be measured as the power level of any discrete signal at the RF input terminal of the receiver. Connect the receiver input terminal to a spectrum analyser or selective voltmeter having an input impedance of 50  $\Omega$  and switch the receiver on.

If the detecting device is not calibrated in terms of power input, the level of any detected components shall be determined by a substitution method using a signal generator.

The measurements shall extend over the frequency range of 9 kHz to 4 GHz.

## 8.10.3 Limits

The power of any conducted spurious emission shall not exceed the values given in Table 4 below:

**Table 4**

Environmental phenomena	Frequency range	Units	Test limits Rx,	Reference bandwidth
Spurious conducted RF Emissions	9 kHz to 150 kHz	dBm	-57 (2 nW)	B = 1 kHz
Spurious conducted RF Emissions	> 150 kHz to 30 MHz	dBm	-57 (2 nW)	B = 9 kHz to 10 kHz
Spurious conducted RF Emissions	> 30 MHz to 1 GHz	dBm	-57 (2 nW) Note	B = 100 kHz to 120 kHz
Spurious conducted RF Emissions	> 1 GHz to 4 GHz	dBm	-47 (20 nW)	B = 1 MHz
NOTE: Spurious limit -81 dBm, with a reference bandwidth of 10 kHz, for ground base station equipment in the band 118 MHz to 136 975 MHz.				

## 8.11 Squelch operation

### 8.11.1 Definition

The purpose of the squelch facility is to mute the receiver audio output signal when the level of the signal at the receiver input is less than a given value.

### 8.11.2 Method of measurement

A signal generator shall be connected to the receiver input:

- a) Squelch mute attenuation:
  - The signal generator shall be set to produce a normal test signal (subclause 6.2.3) at the nominal frequency of the receiver at a level of -53 dBm. The audio output of the receiver shall be measured by an rms voltmeter connected to the receiver through a psophometric filter and shall be adjusted to approximately half the rated output power (subclause 6.1.5). With the signal generator-RF switched off and the squelch muting, the audio output shall be measured again. The difference between these two values is the squelch mute attenuation.
- b) Squelch hysteresis:
  - The signal generator shall be set to produce a normal test signal (subclause 6.1.3). The squelch operating point shall be set to the 12 dB SINAD point. Increase the RF output of the signal generator until the squelch circuit opens and note the corresponding RF level. Decrease the output of the signal generator until the squelch circuit mutes the audio output and note that RF level. The difference between the two recorded levels is the squelch hysteresis.
  - The squelch threshold setting range shall be from below the receiver sensitivity level (subclause 8.1) and the squelch function shall be deselectable.

c) Squelch for offset carrier operation:

- To test 25 kHz channel spaced receivers squelch for offset carrier operation, two signal generators shall be connected to the receiver via a combining network. Each generator shall be set to produce a normal test signal (subclause 6.1.3) at a level of -93 dBm (subclause 8.1). One signal generator shall produce the test signal at the nominal frequency of the receiver with a +5 kHz offset. The other signal generator shall produce the test signal at the nominal frequency of the receiver with a -5 kHz offset.
- Operation of the audio output by the squelch circuit on application of each generator test signal in turn shall be confirmed. Operation of the audio output by the squelch circuit on application of both generator test signals at the same time shall be confirmed.
- The squelch facility shall be unaffected by the presence of heterodynes in the audio band generated by an offset carrier system.
- The squelch facility shall be measured on the mid band test frequency only.

### 8.11.3 Limits

Under the conditions specified in subclause 8.11.2 a), the squelch mute attenuation shall be at least 60 dB for base station equipment and at least 40 dB for mobile, portable and handheld equipment.

Under the conditions specified in subclause 8.11.2 b), the squelch hysteresis shall be within +1 dB and +6 dB.

Carrier override shall operate at levels > -85 dBm.

## 8.12 Cross modulation rejection

### 8.12.1 Definition

Cross modulation is the transposition of the AM component from a strong unwanted signal to the wanted signal.

Cross modulation rejection is the level difference between an unwanted signal and the maximum sensitivity level (as defined in subclause 8.1) at the point where the audio component due to cross modulation tone reduces the SINAD ratio of the wanted signal to 20 dB.

### 8.12.2 Method of measurement

- a) The two input signals shall be connected to the receiver via combining network. An rms voltmeter shall be connected to the receiver output terminals via a psophometric filter.
- b) The wanted signal, a normal test signal (subclause 6.1.3) at the nominal frequency of the receiver, shall be applied to the receiver input connector via one of the inputs of the combining network. The level of the signal will be set to produce a 30 dB SINAD ratio measured at the receiver output using a psophometric telephone filtering network as described in ITU-T Recommendation P.53 [3].
- c) The unwanted signal at a frequency offset of 1 MHz with respect to the nominal frequency of the receiver and amplitude modulated with 400 Hz at a depth of modulation of 30 % shall be applied to the second input of the combining network.
- d) The RF output level of the unwanted signal shall be increased until the 400 Hz tone reduces the SINAD ratio of the wanted signal to 20 dB.

NOTE: The interfering source should be a low noise generator, otherwise additional filtering of the RF signal may be required to prevent wideband noise masking the measurement.

- e) The ratio between this RF level of the unwanted signal and the maximum sensitivity (as defined in subclause 8.1) is the cross modulation rejection.
- f) The measurement shall be repeated for an interfering signal at -1 MHz with respect to the nominal frequency of the receiver.

g) This test shall be performed at the centre test frequency (subclause 6.3) only.

### 8.12.3 Limits

The cross modulation rejection ratio shall be at least 80 dB for base station equipment and 70 dB for mobile portable and handheld equipment.

## 8.13 Receiver dynamic range

### 8.13.1 Definition

The receiver dynamic range expresses the capability of the receiver to limit the resulting audio output as a function of varying input signal levels.

### 8.13.2 Method of measurement

A normal test signal (subclause 6.1.3) with carrier frequency equal to the nominal frequency of the receiver and level equal to the limit of the maximum sensitivity (subclause 8.1) shall be applied to the receiver under normal test conditions (subclause 5.3). The resulting audio output shall be measured by an AF power meter connected to the receiver and the value noted. The RF input level shall then be increased by 100 dB and the AF output level shall again be noted.

### 8.13.3 Limit

The RF automatic gain control shall process an input level change of 100 dB with respect to the limit of the maximum sensitivity level to less than 6 dB resulting audio output power changes.

## 8.14 AGC attack time and release time (data mode only)

### 8.14.1 Definitions

The time taken for the data link audio output to reach 90 % of its steady state value after a 40 dB step application of the input signal.

### 8.14.2 Method of measurement

#### 8.14.2.1 Attack time

The following method of measurement shall be used:

- a) the receiver antenna port is connected to the signal generator output via a switchable 40 dB attenuator.
- b) the receiver data output lines are monitored on a storage oscilloscope.
- c) apply an on channel signal at 127,5 MHz (mid-band test frequency) at a level of -47 dBm, modulated 30 % at 1 kHz, to the attenuator such that a -87 dBm signal is received at the receiver antenna port.
- d) switch out the attenuator and record the time taken for the audio output to settle to 90 % of its steady state level.

A trigger device may be required to ensure that the start of the sweep of the oscilloscope timebase occurs the instant at which the attenuator is switched out.

### 8.14.2.2 AGC Decay time

The following method of measurement shall be used:

- a) the receiver antenna port is connected to the signal generator output via a switchable 40dB attenuator;
- b) the receiver data output lines are monitored on a storage oscilloscope;
- c) apply an on channel signal at 127,5 MHz (mid-band test frequency) at a level of -47 dBm, modulated 30 % at 1 kHz, to the switchable attenuator, which should be switched out so that a -47 dBm signal is received at the receiver antenna port;
- d) switch in the attenuator and record the time taken for the audio output to settle to 90 % of its steady state level.

A trigger device may be required to ensure that the start of the sweep of the oscilloscope timebase occurs the instant at which the attenuator is switched in.

### 8.14.3 Limits

AGC attack time shall be < 40 ms.

AGC decay time shall be < 50 ms.

## 8.15 AF AGC

### 8.15.1 Definition

The AF AGC expresses the capability of the receiver to limit the resulting audio output as a function of varying input modulation depths.

### 8.15.2 Method of Measurement

A normal test signal (subclause 6.1.3) modulated at 60 % with carrier frequency equal to the nominal frequency of the receiver and at a level of -53 dBm shall be applied to the receiver under normal test conditions (subclause 5.3). The resulting audio output shall be measured by an AF power meter connected to the receiver and the value noted. The modulation depth of the RF input shall then be varied between 30 % and 90 % and the AF output level shall again be noted.

### 8.15.3 Limit

Where an AF automatic gain control is fitted, the control shall compress an input modulation depth variation of 30 % to 90 % to an audio output power change of 1,5 dB or less.

## 8.16 Group delay variation (data mode only)

### 8.16.1 Definition

Audio filters do not provide a uniform transmission speed for all frequencies. Consequently, a phase difference can occur between frequencies within the passband. Group delay (or envelope delay) is proportional to the change in slope of the phase shift response versus frequency curve.

### 8.16.2 Receiver method of measurement

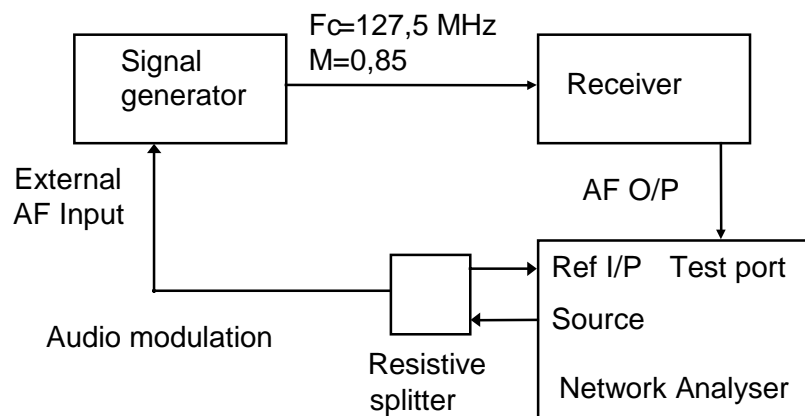

#### NOTE:

- Connect the output of the network analyser to a resistive splitter to give two audio signal outputs.
- Connected one signal to the network analyser reference input, and the second to the receiver via the signal generator with a modulated signal applied to the RF input port.
- Adjust the source level at the network analyser to produce a 85 % modulated signal at 1 kHz.
- The receiver audio output is fed into the test port on the analyser and the network analyser is adjusted to sweep from 100 Hz to 3 kHz with a 30 Hz resolution bandwidth.
- Set the analyser's markers to show the group delay variation between 1,2 kHz and 2,4 kHz.

**Figure 5: Receiver measurement arrangement**

### 8.16.3 Limits

The group delay variation between 1,2 kHz and 2,4 kHz shall be  $< 65 \mu\text{s}$ .

## 9 Measurement uncertainty and interpretation of the measured results

The results of the measurement shall be recorded in the test report.

The measurement uncertainties shall be calculated by the test laboratory performing the measurements and shall also be recorded in the test report.

### 9.1 Maximum measurement uncertainties

The measurement uncertainties shall be better than or equal to those given in Tables 5 and 6.

**Table 5: Transmitter measurement uncertainty: maximum values**

Measurement uncertainties	Maximum values
Frequency error	$\pm 1 \times 10^{-9}$
Carrier power (normal and extreme test conditions)	$\pm 0,75$ dB
Modulation depth	$\pm 3$ %
Modulation compression	$\pm 3$ %
Amplitude modulation distortion	$\pm 3$ %
Audio frequency response	$\pm 2$ dB
Adjacent channel power	$\pm 2,5$ dB
Conducted spurious emissions: below 1 GHz	$\pm 3$ dB
between 1 GHz and 4 GHz	$\pm 6$ dB
Transient frequency behaviour	$\pm 250$ Hz
Intermodulation	$\pm 3$ dB
RF power attack and release times	$\pm 20$ % of the limits values
Keying transient frequency behaviour	$\pm 3$ dB

**Table 6: Receiver measurement uncertainty: maximum values**

Measurement uncertainties	Maximum values
Receiver sensitivity	$\pm 3$ dB
Harmonic distortion	$\pm 0,5$ dB
Audio frequency response	$\pm 2$ dB
Audio noise level	$\pm 3$ dB
Effective acceptance bandwidth	$\pm 3$ dB
Adjacent channel rejection	$\pm 4$ dB
Spurious response rejection	$\pm 4$ dB
Intermodulation response rejection	$\pm 3$ dB
Blocking and desensitization	$\pm 4$ dB
Conducted spurious radiation: below 1 GHz	$\pm 3$ dB
between 1 GHz and 4 GHz	$\pm 6$ dB
Squelch operation	$\pm 3$ dB
Cross modulation rejection	$\pm 4$ dB
Receiver dynamic range	$\pm 2$ dB
50 $\Omega$ VSWR	1:1,2
AF AGC	$\pm 0,5$
Group Delay	$\pm 5$ $\mu$ s

For the test methods according to the present document the uncertainty figures are valid to a confidence level of 95 % calculated according to the methods described in ETR 028 [1].

## 9.2 Interpretation of the measurement results

The interpretation of the results recorded in a test report for the measurements described in the present document shall be as follows:

- the measured value related to the corresponding limit will be used to decide whether an equipment meets the requirements of the present document;
- the measurement uncertainty value for the measurement of each parameter shall be included in the test report;
- the recorded value of the measurement uncertainty shall be, for each measurement, equal to or lower than the values in tables 6 and 7 (tables of measurement uncertainties).



---

## Annex A (normative): Auxiliary cables

The position of auxiliary cables (power supply and microphone cables etc.) which are not adequately decoupled may cause variations in the measuring results. In order to get reproducible results, cables and wires of auxiliaries should be arranged vertically downwards (through a hole in the non-conducting support).

## Annex B (normative): Specification for adjacent channel power measurement arrangements

### B.1 Power measuring receiver specification

The power measuring receiver consists of a mixer, an Intermediate Frequency (IF) filter, and oscillator, an amplifier, a variable attenuator and an rms value indicator. Instead of the variable attenuator with the rms value indicator it is also possible to use an rms voltmeter calibrated in dB. The technical characteristics of the power measuring receiver are given below.

#### B.1.1 IF filter

The IF filter shall be within the limits of the following selectivity characteristics.

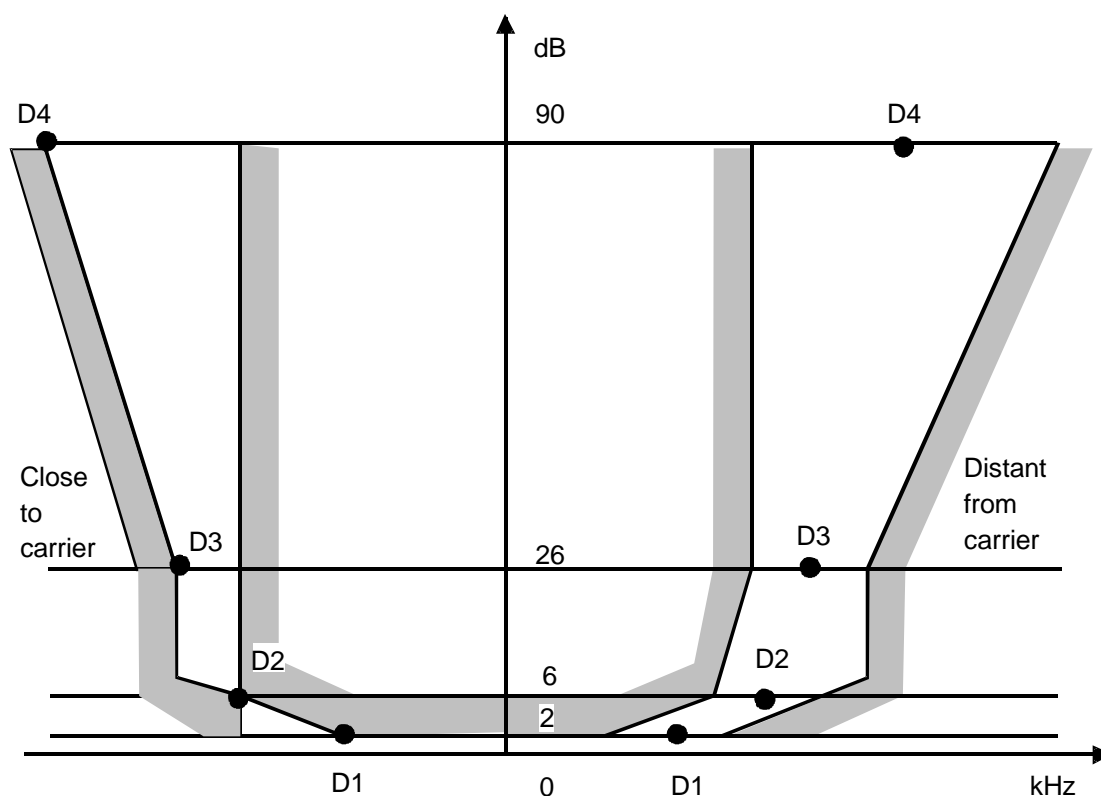

Figure B.1: Limits of the selectivity characteristic

The selectivity characteristic shall keep the following frequency separations from the nominal centre frequency of the adjacent channel:

Table B.1: Selectivity characteristic

Frequency separation of filter curve from nominal centre frequency of adjacent channel (kHz)				
	D1	D2	D3	D4
8,33kHz Spacing	2,5	3,5	4	5,8
25kHz Spacing	5	8	9,25	13,25

The attenuation points shall not exceed the following tolerances:

**Table B.2: Attenuation points close to carrier**

Tolerance range (kHz)				
	D1	D2	D3	D4
8,33kHz Spacing	+0,9	$\pm 0,1$	-0,4	-2,2
25kHz Spacing	3,1	$\pm 0,1$	-1,35	-5,35

**Table B.3: Attenuation points distant from the carrier**

Tolerance range (kHz)				
	D1	D2	D3	D4
8,33kHz Spacing	$\pm 1$	$\pm 1$	$\pm 1$	+2/-4
25kHz Spacing	$\pm 3,5$	$\pm 3,5$	$\pm 3,5$	+3,5/-7,5

The minimum attenuation of the filter outside the 90 dB attenuation points shall be equal to or greater than 90 dB.

## B.1.2 Attenuation indicator

The attenuation indicator shall have a minimum range of 70 dB and a reading accuracy of 1 dB.

## B.1.3 RMS value indicator

The instrument shall accurately indicate non-sinusoidal signals in a ratio of up to 10:1 between peak value and rms value.

## B.1.4 Oscillator and amplifier

The crystal oscillator and the amplifier shall be designed in such a way that the measurement of the adjacent channel power of a low-noise unmodulated transmitter, whose self-noise has a negligible influence on the measurement result, yields a measured value of <-80 dB.

---

## Bibliography

The following material, though not specifically referenced in the body of the present document (or not publicly available), gives supporting information.

ICAO Annex 10 Volume III Part 2 (1995): "Voice Communication Systems".

---

## History

<b>Document history</b>		
Edition 1	March 1997	Published as ETS 300 676
V1.2.1	December 1999	One-step Approval Procedure      OAP 200016: 1999-12-22 to 2000-04-21