

ETSI EN 300 674-2-2 V2.2.1 (2019-06)



HARMONISED EUROPEAN STANDARD

**Transport and Traffic Telematics (TTT);
Dedicated Short Range Communication (DSRC)
transmission equipment (500 kbit/s / 250 kbit/s)
operating in the 5 795 MHz to 5 815 MHz frequency band;
Part 2: Harmonised Standard for access to radio spectrum;
Sub-part 2: On-Board Units (OBU)**

Reference

REN/ERM-TG37-272

Keywords

data, DSRC, harmonised standard, radio,
regulation, RTTT, testing

ETSI

650 Route des Lucioles
F-06921 Sophia Antipolis Cedex - FRANCE

Tel.: +33 4 92 94 42 00 Fax: +33 4 93 65 47 16

Siret N° 348 623 562 00017 - NAF 742 C
Association à but non lucratif enregistrée à la
Sous-Préfecture de Grasse (06) N° 7803/88

Important notice

The present document can be downloaded from:

<http://www.etsi.org/standards-search>

The present document may be made available in electronic versions and/or in print. The content of any electronic and/or print versions of the present document shall not be modified without the prior written authorization of ETSI. In case of any existing or perceived difference in contents between such versions and/or in print, the prevailing version of an ETSI deliverable is the one made publicly available in PDF format at www.etsi.org/deliver.

Users of the present document should be aware that the document may be subject to revision or change of status.

Information on the current status of this and other ETSI documents is available at

<https://portal.etsi.org/TB/ETSIDeliverableStatus.aspx>

If you find errors in the present document, please send your comment to one of the following services:

<https://portal.etsi.org/People/CommiteeSupportStaff.aspx>

Copyright Notification

No part may be reproduced or utilized in any form or by any means, electronic or mechanical, including photocopying and microfilm except as authorized by written permission of ETSI.

The content of the PDF version shall not be modified without the written authorization of ETSI.

The copyright and the foregoing restriction extend to reproduction in all media.

© ETSI 2019.

All rights reserved.

DECT™, **PLUGTESTS™**, **UMTS™** and the ETSI logo are trademarks of ETSI registered for the benefit of its Members.

3GPP™ and **LTE™** are trademarks of ETSI registered for the benefit of its Members and of the 3GPP Organizational Partners.

oneM2M™ logo is a trademark of ETSI registered for the benefit of its Members and of the oneM2M Partners.

GSM® and the GSM logo are trademarks registered and owned by the GSM Association.

Contents

Intellectual Property Rights	6
Foreword.....	6
1 Scope	8
2 References	8
2.1 Normative references	8
2.2 Informative references.....	9
3 Definition of terms, symbols and abbreviations.....	9
3.1 Terms.....	9
3.2 Symbols.....	11
3.3 Abbreviations	13
4 Technical requirements specifications	14
4.1 General characteristics	14
4.1.1 OBU sets.....	14
4.1.2 Uplink sub-carrier frequencies.....	14
4.1.3 Carrier frequencies.....	14
4.1.4 Modulation.....	14
4.2 Environmental conditions.....	15
4.2.1 Environmental profile.....	15
4.2.2 Power supply	15
4.3 Conformance requirements	15
4.3.1 Transmitter requirements	15
4.3.1.1 Transmitter spectrum mask	15
4.3.1.2 Maximum equivalent isotropically radiated power	15
4.3.1.3 Transmitter frequency error	16
4.3.1.4 Transmitter unwanted emissions.....	16
4.3.2 Receiver requirements	16
4.3.2.1 Receiver unwanted emissions in the spurious domain	16
4.3.2.2 Sensitivity	17
4.3.2.3 Receiver selectivity	17
4.3.2.3.1 General	17
4.3.2.3.2 Receiver spurious response rejection and adjacent channel rejection	17
4.3.2.3.3 Receiver blocking.....	18
4.3.2.3.4 Co-channel rejection.....	18
4.3.3 Antennas	18
5 Testing for compliance with technical requirements.....	19
5.1 Environmental conditions for testing	19
5.2 Interpretation of the measurement results	19
5.3 Radio test suites.....	20
5.3.1 Transmitter parameters	20
5.3.1.1 Transmitter spectrum mask	20
5.3.1.1.1 General	20
5.3.1.1.2 Radiated measurements	20
5.3.1.1.3 Conducted measurements	22
5.3.1.2 Maximum equivalent isotropically radiated power	23
5.3.1.2.1 General	23
5.3.1.2.2 Radiated measurement.....	24
5.3.1.2.3 Conducted measurement.....	25
5.3.1.3 Transmitter frequency error	25
5.3.1.3.1 General	25
5.3.1.3.2 Radiated measurements	26
5.3.1.3.3 Conducted measurements	26
5.3.1.4 Transmitter unwanted emissions	27
5.3.1.4.1 General	27
5.3.1.4.2 Radiated measurement.....	27

5.3.2	Receiver parameters.....	28
5.3.2.1	Receiver unwanted emissions in the spurious domain	28
5.3.2.1.1	General	28
5.3.2.1.2	Radiated measurement.....	28
5.3.2.2	Sensitivity	29
5.3.2.2.1	General	29
5.3.2.2.2	Radiated measurements	29
5.3.2.2.3	Conducted measurements	29
5.3.2.3	Receiver selectivity	30
5.3.2.3.1	General	30
5.3.2.3.2	Unwanted signal characteristics	30
5.3.2.3.3	Measurement of receiver selectivity in OBU boresight.....	30
Annex A (informative): Relationship between the present document and the essential requirements of Directive 2014/53/EU		32
Annex B (normative): Basics on testing		33
B.1	General conditions.....	33
B.1.1	Thermal balance	33
B.1.2	Test signals	33
B.1.3	Test sites.....	34
B.1.3.1	Shielded anechoic chamber.....	34
B.1.3.2	Open area test site	35
B.1.3.3	Test fixture.....	35
B.1.4	General requirements for RF cables	36
B.1.5	Conducted measurements.....	37
B.1.5.1	One antenna connector arrangement.....	37
B.1.5.2	Two antenna connectors arrangement.....	38
B.1.5.3	Test site requirements	38
B.1.5.4	Site preparation for conducted measurements	38
B.1.5.4.1	Monochromatic signals	38
B.1.5.4.2	Modulated signals	38
B.1.6	Radiated measurements	39
B.1.6.1	One antenna arrangement	39
B.1.6.2	Two antennas arrangement	40
B.1.6.3	Test site requirements	41
B.1.6.3.1	Measurement distances	41
B.1.6.3.2	Free-space wave propagation	41
B.1.6.4	Test and substitution antennas	42
B.1.6.5	Site preparation for radiated OBU measurements	42
B.1.6.5.1	Monochromatic signals	42
B.1.6.5.2	Modulated signals	44
B.1.6.5.3	Arrangement for OBU transmitter unwanted emissions measurement	45
B.1.6.5.4	Arrangement for OBU receiver selectivity measurement	47
B.2	Instruments	49
B.2.1	Receiving device	49
B.2.2	RF power sensor.....	49
B.2.3	Combiner.....	50
B.3	Power of modulated RSU carrier	50
B.4	Bit error ratio measurements	51
B.4.1	Basics	51
B.4.2	BER measurement	51
B.4.3	FER measurement	51
B.4.3.1	Mathematical expressions.....	51
B.4.3.2	Equipment.....	52
B.4.3.3	Procedure.....	52
Annex C (normative): Environmental profile		53
C.1	General Requirements	53

C.2	Mandatory environmental conditions.....	53
C.3	Additional environmental conditions	53
Annex D (informative):	Maximum Measurement Uncertainty.....	54
Annex E (informative):	Bibliography.....	55
Annex F (informative):	Change History	56
History		57

Intellectual Property Rights

Essential patents

IPRs essential or potentially essential to normative deliverables may have been declared to ETSI. The information pertaining to these essential IPRs, if any, is publicly available for **ETSI members and non-members**, and can be found in ETSI SR 000 314: "*Intellectual Property Rights (IPRs); Essential, or potentially Essential, IPRs notified to ETSI in respect of ETSI standards*", which is available from the ETSI Secretariat. Latest updates are available on the ETSI Web server (<https://ipr.etsi.org/>).

Pursuant to the ETSI IPR Policy, no investigation, including IPR searches, has been carried out by ETSI. No guarantee can be given as to the existence of other IPRs not referenced in ETSI SR 000 314 (or the updates on the ETSI Web server) which are, or may be, or may become, essential to the present document.

Trademarks

The present document may include trademarks and/or tradenames which are asserted and/or registered by their owners. ETSI claims no ownership of these except for any which are indicated as being the property of ETSI, and conveys no right to use or reproduce any trademark and/or tradename. Mention of those trademarks in the present document does not constitute an endorsement by ETSI of products, services or organizations associated with those trademarks.

Foreword

This Harmonised European Standard (EN) has been produced by ETSI Technical Committee Electromagnetic compatibility and Radio spectrum Matters (ERM).

The present document has been prepared under the Commission's standardisation request C(2015) 5376 final [i.3] to provide one voluntary means of conforming to the essential requirements of Directive 2014/53/EU on the harmonisation of the laws of the Member States relating to the making available on the market of radio equipment and repealing Directive 1999/5/EC [i.2].

Once the present document is cited in the Official Journal of the European Union under that Directive, compliance with the normative clauses of the present document given in table A.1 confers, within the limits of the scope of the present document, a presumption of conformity with the corresponding essential requirements of that Directive and associated EFTA regulations.

The present document is part 2, sub-part 2 of a multi-part deliverable covering Transport and Traffic Telematics (TTT); Dedicated Short Range Communication (DSRC) transmission equipment (500 kbit/s / 250 kbit/s) operating in the 5 795 MHz to 5 815 MHz frequency band, as identified below:

Part 1: "General characteristics and test methods for Road Side Units (RSU) and On-Board Units (OBU)";

Part 2: "Harmonised Standard for access to radio spectrum";

Sub-part 1: "Road Side Units (RSU)";

Sub-part 2: "On-Board Units (OBU)".

National transposition dates	
Date of adoption of this EN:	17 June 2019
Date of latest announcement of this EN (doa):	30 September 2019
Date of latest publication of new National Standard or endorsement of this EN (dop/e):	31 March 2020
Date of withdrawal of any conflicting National Standard (dow):	31 March 2021

In the present document "**shall**", "**shall not**", "**should**", "**should not**", "**may**", "**need not**", "**will**", "**will not**", "**can**" and "**cannot**" are to be interpreted as described in clause 3.2 of the [ETSI Drafting Rules](#) (Verbal forms for the expression of provisions).

"**must**" and "**must not**" are **NOT** allowed in ETSI deliverables except when used in direct citation.

1 Scope

The present document specifies technical characteristics and methods of measurements for Transport and Traffic Telematics (TTT) systems:

- with a Radio Frequency (RF) output connection and specified antenna or with an integral antenna;
- for data transmission only;
- operating in the 5 795 MHz to 5 815 MHz frequency band.

The applicability of the present document covers only the On Board Units (OBU).

The present document complies with the Commission Implementing Decision 2017/1483/EU [i.4] and CEPT/ERC Recommendation 70-03 [i.6].

The present document applies to the following radio equipment types operating in all or in part of the following service frequency bands given in table 1.

Table 1: Frequency bands and centre frequencies f_{TX} allocated for DSRC

	Pan European Service Frequencies	National Service Frequencies
Channel 1	5,795 GHz to 5,800 GHz, $f_{TX} = 5,7975$ GHz	
Channel 2	5,800 GHz to 5,805 GHz, $f_{TX} = 5,8025$ GHz	
Channel 3		5,805 GHz to 5,810 GHz, $f_{TX} = 5,8075$ GHz
Channel 4		5,810 GHz to 5,815 GHz, $f_{TX} = 5,8125$ GHz

NOTE: The relationship between the present document and essential requirements of article 3.2 of Directive 2014/53/EU [i.2] is given in annex A.

2 References

2.1 Normative references

References are specific, identified by date of publication and/or edition number or version number. Only the cited version applies.

Referenced documents which are not found to be publicly available in the expected location might be found at <https://docbox.etsi.org/Reference/>.

NOTE: While any hyperlinks included in this clause were valid at the time of publication, ETSI cannot guarantee their long term validity.

The following referenced documents are necessary for the application of the present document.

- [1] CEN EN 12253 (2004): "Road transport and traffic telematics - Dedicated short-range communication - Physical layer using microwave at 5,8 GHz".
- [2] ISO 14906 (2018): "Electronic fee collection -- Application interface definition for dedicated short-range communication".
- [3] CEPT/ERC Recommendation 74-01E (2011): "Unwanted emissions in the spurious domain".
- [4] CEN EN 13372 (2004): "Road Transport and Traffic Telematics (RTTT) - Dedicated short-range communication - Profiles for RTTT applications".

2.2 Informative references

References are either specific (identified by date of publication and/or edition number or version number) or non-specific. For specific references, only the cited version applies. For non-specific references, the latest version of the referenced document (including any amendments) applies.

NOTE: While any hyperlinks included in this clause were valid at the time of publication, ETSI cannot guarantee their long term validity.

The following referenced documents are not necessary for the application of the present document but they assist the user with regard to a particular subject area.

- [i.1] ETSI TS 103 052 (V1.1.1) (03-2011): "Electromagnetic compatibility and Radio spectrum Matters (ERM); Radiated measurement methods and general arrangements for test sites up to 100 GHz".
- [i.2] Directive 2014/53/EU of the European Parliament and of the Council of 16 April 2014 on the harmonisation of the laws of the Member States relating to the making available on the market of radio equipment and repealing Directive 1999/5/EC.
- [i.3] Commission Implementing Decision C(2015) 5376 final of 4.8.2015 on a standardisation request to the European Committee for Electrotechnical Standardisation and to the European Telecommunications Standards Institute as regards radio equipment in support of Directive 2014/53/EU of the European Parliament and of the Council.
- [i.4] Commission Implementing Decision (EU) 2017/1483 of 8 August 2017 amending Decision 2006/771/EC on harmonisation of the radio spectrum for use by short-range devices and repealing Decision 2006/804/EC" .
- [i.5] Void.
- [i.6] CEPT/ERC Recommendation 70-03 (May 2018): "Relating to the use of Short Range Devices (SRD)".
- [i.7] ETSI TR 102 273-2 (V1.2.1) (12-2001): "Electromagnetic compatibility and Radio spectrum Matters (ERM); Improvement on Radiated Methods of Measurement (using test site) and evaluation of the corresponding measurement uncertainties; Part 2: Anechoic chamber".
- [i.8] ETSI TR 102 273-6 (V1.2.1) (12-2001): "Electromagnetic compatibility and Radio spectrum Matters (ERM); Improvement on Radiated Methods of Measurement (using test site) and evaluation of the corresponding measurement uncertainties; Part 6: Test fixtures".
- [i.9] IEC 60721-3-4 (1995) including Amendment 1 (1996): "Classification of environmental conditions - Part 3: Classification of groups of environmental parameters and their severities - Section 4: Stationary use at non-weather protected locations".
- [i.10] IEC 60721-3-5 (1997): "Classification of environmental conditions - Part 3: Classification of groups of environmental parameters and their severities - Section 5: Ground vehicle installations".

3 Definition of terms, symbols and abbreviations

3.1 Terms

For the purposes of the present document, the terms given in Directive 2014/53/EU [i.2] and the following apply:

adjacent channel: channel at a distance of 5 MHz relative to the centre frequency, i.e. in the channel at the next upper or lower centre frequency within the frequency band allocated for DSRC (see table 3)

bit: acronym for "binary digit" which can have one out of two possible values

EXAMPLE: 0/1, or +1/-1, or low/high.

bit rate: in a bit stream, the number of bits occurring per unit time, usually expressed in bits per second

boresight: direction of maximum radiation of a directional antenna

NOTE: If boresight cannot be determined unambiguously, then boresight may be declared by the manufacturer.

carrier frequency: frequency f_{TX} to which the RSU transmitter is tuned

NOTE: In DSRC, the carrier frequency is in the centre of a channel, see table 3 of the present document.

carrier signal or carrier: harmonic signal whose nominal single frequency f_{TX} can vary within a range specified by the carrier frequency tolerance and which is capable of being modulated by a second, symbol-carrying signal

channel: continuous part of the radio-frequency spectrum to be used for a specified emission or transmission

NOTE: A radio-frequency channel may be defined by two specified limits, or by its centre frequency and its bandwidth, or any equivalent indication. It is often designated by a sequential number. A radio-frequency channel may be time-shared in order to allow radio communication in both directions by simplex operation. The term "channel" is sometimes used to denote two associated radio-frequency channels, each of which is used for one of two directions of transmission, i.e. in fact a telecommunication circuit.

co-channel: transmission using the same channel (frequency band of 5 MHz width)

cross-polar discrimination (XPD): the ratio P_{LHCP} / P_{RHCP} of power P_{LHCP} of the left hand circular polarized wave to the power P_{RHCP} of the right hand circular wave when the total power of the transmitted wave is $P_{LHCP} + P_{RHCP}$

downlink: transmission in direction from RSU to OBU

ellipticity of polarization: ratio of the polarization main axes of an elliptic polarized radio wave

EXAMPLE: The ellipticity of circular polarized radio waves is one.
The ellipticity of linear polarized waves is infinity.

environmental profile: range of environmental conditions

equivalent isotropically radiated power: signal power fed into an ideal loss-less antenna radiating equally in all directions that generates the same power flux at a reference distance as the one generated by a signal fed into the antenna under consideration in a predefined direction within its far field region

integral antenna: antenna, with or without a connector, designed as an indispensable part of the equipment

OBU sleep mode: optional mode for battery powered OBUs that allows to save battery power

NOTE: In this mode, the OBU can only detect the presence of a DSRC downlink signal to initiate under certain defined conditions a transition to the stand-by mode.

OBU stand-by mode: mode, in which the OBU is capable of receiving DSRC downlink signals, but is never transmitting

operating frequency: nominal frequency at which equipment is operated; also referred to as the operating centre frequency

NOTE: Equipment may be able to operate at more than one operating frequency.

out-of-band emissions: emissions on a frequency or frequencies immediately outside the necessary bandwidth which results from the modulation process and which cannot be reduced without affecting the corresponding transmission of information, but excluding spurious emissions (see also CEPT/ERC Recommendation 74-01E [3])

polarization: locus of the tip of the electrical field vector in a plane perpendicular to the direction of transmission

EXAMPLE: Horizontal and vertical linear polarization
Left and right hand circular polarization.

Portable Equipment (PE): generally intended to be self-contained, free standing and portable

NOTE: A PE would normally consist of a single module, but may consist of several interconnected modules. It is powered by one or more internal batteries.

radiated measurements: measurements which involve the measurement of a radiated electromagnetic field

spurious emissions: emission on a frequency, or frequencies, which are outside an exclusion band of $\pm 2,5$ times the channel spacing around the selected centre frequency f_{Tx} , and the level of which may be reduced without affecting the corresponding transmission of information

NOTE: Spurious emissions include harmonic emissions, parasitic emissions, intermodulation products and frequency conversion products but exclude out-of-band emissions (see also CEPT/ERC Recommendation 74-01E [3]).

uplink: transmission in direction from OBU to RSU

3.2 Symbols

For the purposes of the present document, the following symbols apply:

A_{CW}	Amplitude of CW signal
A_{mod}	Amplitude of modulated signal
ATN_{AT2}	Attenuation of attenuator AT2
ATN_{BLN}	Attenuation of balun BLN
ATN_{CA1}	Attenuation of coaxial cable 1
BER	Bit error ratio
C_F	Number of frames transmitted
C_E	Number of erroneous frames received
d	Distance between phase centres of transmitting and receiving antenna
$d_{displace}$	Horizontal displacement of TTA and RTA antenna phase centres
d_{F1}	Distance from transmitting antenna to first Fresnel ellipse
d_{F2}	Distance from first Fresnel ellipse to receiving antenna
D_{fb}	Distance between neighbouring ferrite beads
D_i	Directivity relative to an isotropic radiator
$D_{0,TA}$	Largest linear dimension of test antenna
$D_{0,EUT}$	Largest linear dimension of EUT antenna
$EIRP_{max}$	Maximum e.i.r.p. of RSU
$EIRP_{MaxObuTx}$	Maximum e.i.r.p. generated by the OBU in a single side band
$EIRP_{ObuTx}$	e.i.r.p. generated by the OBU within a single side band
$EIRP_{OBU}$	e.i.r.p. generated by the OBU antenna
$EIRP_{TSM}$	e.i.r.p. referred to transmitter spectrum mask
Δf_{RSU}	Frequency error of RSU
Δf_s	Sub-carrier frequency error
f	Frequency
f_c	Centre frequency of receiving device or of MSS2 used for calibration
FER	Frame error ratio
f_{ObuTx}	Actual centre frequency of the lower and upper side band of the OBU uplink channel
f_{MSS1}	Frequency of MSS1
f_{offset}	Offset frequency
f_s	Nominal OBU sub-carrier frequency
f_{Tx}	Nominal RSU carrier frequency
$f_{Tx,actual}$	Actual centre frequency of the downlink carrier
f_u	Nominal centre frequency of unwanted signal
f_{u1}, f_{u2}	Centre frequencies of unwanted signal
G_c	Conversion gain
G_{corr}	Correction gain
$G_{OBU,Rx}$	Gain of OBU receiving antenna
$G_{OBU,Tx}$	Gain of OBU transmitting antenna

G_{RSA}	Gain of receiving substitution antenna
G_{TA}	Gain of test antenna
G_{TSA}	Gain of transmitting substitution antenna
$G_{\text{RSU,Tx}}$	Gain of RSU transmitting antenna
k	Expansion factor (coverage factor)
$\lg(\cdot)$	Logarithm to the base ten
m	Modulation index
Mc	Location of the OBU antenna phase centre
N	Total number of transmitted bits within a single frame
P_{CW}	Power of CW signal
P_{D11a}	Power limit for communication (upper)
P_{D11b}	Power limit for communication (lower)
P_{inc}	Incident signal power as received by an ideal isotropical receiving antenna
$P_{\text{inc,scan}}$	Incident signal power obtained from a scanning process
$P_{\text{inc,dBm}}$	P_{inc} in dBm
P_{LHCP}	Signal power of left hand circular polarized wave
P_{max}	Maximum signal power
P_{mod}	Power of modulated signal
P_{MMS1}	Output signal power of MSS1
P_{MMS2}	Output signal power of MSS2
P_{ObuRx}	Incident signal power to OBU, referred to an ideal isotropical receiving antenna
P_{pol}	Signal power of wave with corresponding polarization
P_{v}	Signal power of wave featuring vertical polarization
P_{h}	Signal power of wave featuring horizontal polarization
P_{PM1}	Signal power measured by the power meter 1
P_{ref}	Reference signal power limit in Watt
$P_{\text{ref,dBm}}$	Reference signal power limit in dBm
P_{reTx}	Retransmitted signal power
P_{RSA}	Signal power obtained from receiving substitution antenna
P_{RHCP}	Signal power of right hand circular polarized wave
P_{ssb}	Signal power within single side band
P_{sens}	Sensitivity of receiver
P_{spurious}	Signal power of spurious signal
P_{tot}	Sum of signal power $P_1 + P_2$, or $P_1 + P_2 + \dots + P_5$, whichever applies
$P_{\text{tot,dBm}}$	P_{tot} in dBm
P_{TSM}	Transmitter spectrum mask
P_{u}	Power of unwanted signal at OBU antenna
$P_{\text{u max}}$	Unwanted signal power limit at OBU antenna
P_{w}	Signal power of wanted signal
P_0	Reference signal power of 1 mW corresponding to 0 dBm
RBW	Resolution bandwidth
T_{CW}	Duration of CW signal
T_{mod}	Duration of modulated signal
$V_{\text{max}}, V_{\text{min}}$	Maximal amplitude of modulated output signal of RSU caused by data bit 1, or 0
α	Tilt angle of test antenna
α_{displace}	Displacement angle between TTA and RTA
θ	Angle relative to OBU boresight indicating worst case direction
θ°	Value of θ measured in degree
λ	Wavelength
ρ_{RSA}	Reflection coefficient at antenna connector of the receiving substitution antenna
ρ_{TSA}	Reflection coefficient at antenna connector of the transmitting substitution antenna

3.3 Abbreviations

For the purposes of the present document the abbreviations given in CEN EN 12253 [1] and the following apply:

ASG	Arbitrary Signal Generator
AT1	ATtenuator 1
AT2	ATtenuator 2
BER	Bit Error Ratio
BLN	BaLuN
BST	Beacon Service Table
CA	Corresponding Antenna
CC	Coaxial Circulator
CRC	Cyclic Redundancy Checking
CW	Continuous Wave
DSRC	Dedicated Short Range Communication
e.i.r.p.	equivalent isotropically radiated power

NOTE: Also called EIRP, eirp, E.I.R.P.

EC	European Community
EUT	Equipment Under Test
FCCA	Ferrited Coaxial CAble
FCCA1	Ferrited Coaxial CAble 1
FER	Frame Error Ratio
LHCP	Left Hand Circular Polarized
LOS	Line-Of-Sight
LP	Linear Polarized
M_{centre}	Centre point between phase centres of TTA and RTA
MSS1	Monochromatic Signal Source 1
MSS2	Monochromatic Signal Source 2
n.a.	not applicable
OBU	On Board Unit
PE	Portable Equipment
PM1	Power Meter 1
RBW	Resolution BandWidth
RD	Receiving Device
RF	Radio Frequency
RRxA	RSU Receiving Antenna
RSA	Receiving Substitution Antenna
RSU	Road Side Unit
RTA	Receiving Test Antenna
RTTT	Road Transport and Traffic Telematics
RTxA	RSU Transmitting Antenna
Rx	Receiver
SMS1	Signal or Message Source 1
SR	Special Report
SSB	Single Side Band
TA	Test Antenna
TM1	Test Message 1
TS1	Test Signal 1
TS2	Test Signal 2
TSA	Transmitting Substitution Antenna
TSM	Transmitter Spectrum Mask
TTA	Transmitting Test Antenna
Tx	Transmitter
VBW	Video Band Width
VST	Vehicle Service Table
VSWR	Voltage Standing Wave Ratio
XP	Cross Polarized
XPD	Cross-Polar Discrimination

4 Technical requirements specifications

4.1 General characteristics

4.1.1 OBU sets

There exist two sets of OBUs called Set A and Set B which differ by the parameters in table 2 either in terms of value or applicability, and which are defined in CEN EN 13372 [4].

Table 2: Differences in OBU Sets

CEN EN 12253 [1] parameter abbreviation	Set A	Set B
D11a		Power limit for communication (upper): See table 12
D12	n.a.	Cut off power level of OBU: -60 dBm
U4a		Maximum SSB e.i.r.p. (boresight): See table 5
U4b	n.a.	Maximum SSB e.i.r.p.: See table 5
U12b	n.a.	Conversion gain (upper limit): 10 dB for each side band

The manufacturer shall declare which Set the unit complies with.

4.1.2 Uplink sub-carrier frequencies

The sub-carrier signal or sub-carrier is a signal whose nominal single frequency f_s can vary within a range specified by the sub-carrier frequency tolerance and which shall be capable of being modulated by a second, symbol-carrying signal, see clause 4.1.4.

The uplink sub-carrier frequency is referred to as parameter U1 in CEN EN 12253 [1].

Every DSRC OBU shall support the two sub-carrier frequencies f_s of 1,5 MHz and 2,0 MHz.

4.1.3 Carrier frequencies

According to parameter D3 in CEN EN 12253 [1] every OBU shall be able to operate in all DSRC channels as indicated in table 3.

For tests of OBU parameters described in the present document, only the carrier frequencies f_{Tx} defined for channel 1 and channel 4 in table 3 shall be considered.

Table 3: Frequency bands and centre frequencies f_{Tx} allocated for DSRC

	Pan European Service Frequencies	National Service Frequencies
Channel 1	5,795 GHz to 5,800 GHz, $f_{Tx} = 5,7975$ GHz	n.a.
Channel 2	5,800 GHz to 5,805 GHz, $f_{Tx} = 5,8025$ GHz	n.a.
Channel 3	n.a.	5,805 GHz to 5,810 GHz, $f_{Tx} = 5,8075$ GHz
Channel 4	n.a.	5,810 GHz to 5,815 GHz, $f_{Tx} = 5,8125$ GHz

4.1.4 Modulation

The uplink sub-carrier (see clause 4.1.2) shall be modulated according to parameters U1b, U6, U6b and U6c defined in CEN EN 12253 [1]. The modulated uplink sub-carrier then shall be used to modulate the carrier at frequency f_{Tx} received from a RSU, i.e. the modulated sub-carrier shall be multiplied with the received carrier.

4.2 Environmental conditions

4.2.1 Environmental profile

The technical requirements of the present document shall apply under the mandatory environmental profile for intended operation of the equipment as specified in clause C.2. The equipment shall comply with all the technical requirements of the present document which are identified as applicable in annex A at all times when operating within the boundary limits of the mandatory environmental profile.

The manufacturer may additionally select environmental profiles specified in clause C.3 for testing.

4.2.2 Power supply

All the characteristics and essential requirements applying to OBUs shall be fulfilled within the range of all declared operational conditions of the power supply.

Power supply may be e.g. a built-in battery, an external battery or a stabilized power supply.

The behaviour of the OBU shall be within the limits specified in the present document, independently of voltages in the range of maximum and decreasing until the OBU switch off transmissions.

4.3 Conformance requirements

4.3.1 Transmitter requirements

4.3.1.1 Transmitter spectrum mask

The OBU transmitter spectrum mask (TSM) is the maximum e.i.r.p. allowed to be transmitted by the OBU within specified frequency bands. The frequency bands are defined by their centre frequencies and bandwidths according to table 4 considering carrier frequencies f_{Tx} in accordance with clause 4.1.3.

The OBU TSM is referred to as parameter U2 in CEN EN 12253 [1].

Table 4: OBU TSM upper limits

Measurement centre frequency	$f_{Tx} \pm 1,5$ MHz, $f_{Tx} \pm 2$ MHz, $f_{Tx} \pm 3$ MHz, $f_{Tx} \pm 3,5$ MHz, $f_{Tx} \pm 6,5$ MHz, and $f_{Tx} \pm 7$ MHz (see note)
Bandwidth	500 kHz
Limit (e.i.r.p.)	Set A: -39 dBm Set B: -35 dBm
NOTE: Measurement shall not be performed at the used sub-carrier frequency, i.e. 1,5 MHz or 2 MHz.	

The maximum e.i.r.p. shall not exceed the limit as stated in table 4.

4.3.1.2 Maximum equivalent isotropically radiated power

The OBU maximum SSB equivalent isotropically radiated power $EIRP_{MaxObuTx}$ is the e.i.r.p. of the OBU in a single side band measured within the valid range of incident signal power P_{D11a} according table 12 and $P_{D11b} = -43$ dBm, according to parameter D11b of CEN EN 12253 [1]. The maximum e.i.r.p. shall not exceed the limits stated in table 5.

Table 5: Limits for OBU maximum SSB e.i.r.p.

Limits for OBU maximum SSB e.i.r.p.				
CEN	Set A		Set B	
Parameter	U4b	U4a	U4b	U4a
Direction	(35°) (see note)	boresight	(35°) (see note)	boresight
Value (e.i.r.p.)	n.a.	-21 dBm	-17 dBm	-14 dBm
NOTE: 35° denotes the opening angle θ of a cone symmetrically around boresight, see figure 1.				

4.3.1.3 Transmitter frequency error

The relative sub-carrier frequency error Δf_s of the OBU is defined by:

$$\Delta f_s = \frac{|f_{\text{ObuTx}} - f_{\text{Tx,actual}}|}{f_s} - 1,$$

where f_{ObuTx} is, respectively, the actual centre frequency of the lower and upper side band of the OBU uplink channel, $f_{\text{Tx,actual}}$ is the actual centre frequency of the downlink carrier, and f_s is the nominal sub-carrier frequency.

The sub-carrier frequency error is referred to as parameter U1a in CEN EN 12253 [1].

The absolute value $|\Delta f_s|$ of the relative OBU sub-carrier frequency error Δf_s shall not exceed 0,1 %.

4.3.1.4 Transmitter unwanted emissions

When the OBU is in operating mode (i.e. transmitting a modulated signal), the e.i.r.p. of any unwanted emissions, i.e. spurious or out-of-band emission, shall not exceed the limits presented in table 6 and defined in table 2.1 of CEPT/ERC Recommendation 74-01E [3].

Measurements shall not be performed within an exclusion band of $\pm 2,5$ times the DSRC channel spacing of 5 MHz, i.e. $\pm 12,5$ MHz around the RSU carrier frequency f_{Tx} under test.

Table 6: Limits of unwanted emissions as specified in CEPT/ERC Recommendation 74-01E [3] table 2.1 reference number 2.1.2 for transmitters

Mode	Frequency bands	Limits (e.i.r.p.)	Reference bandwidth	Type of emission
Operating	47 MHz to 74 MHz 87,5 MHz to 118 MHz 174 MHz to 230 MHz 470 MHz to 862 MHz	-54 dBm	100 kHz	Spurious and out-of-band emissions
	Other frequencies > 30 MHz and \leq 1 GHz	-36 dBm	100 kHz	
	Frequencies > 1 GHz and < 26 GHz outside the exclusion band	-30 dBm	1 MHz	

4.3.2 Receiver requirements

4.3.2.1 Receiver unwanted emissions in the spurious domain

Stand-by mode is a mode, in which the OBU never transmits.

The e.i.r.p. of any spurious emission when the OBU is in stand-by mode shall not exceed the limits presented in table 7 and defined in table 2.1 of CEPT/ERC Recommendation 74-01E [3].

Measurements shall not be performed within an exclusion band of $\pm 2,5$ times the DSRC channel spacing of 5 MHz, i.e. $\pm 12,5$ MHz around the RSU carrier frequency f_{Tx} under test.

Table 7: Limits of unwanted emissions as specified in CEPT/ERC Recommendation 74-01E [3] table 2.1 reference number 2.1.4 for receivers

Mode	Frequency bands	Limits (e.i.r.p.)	Reference bandwidth	Type of emission
Stand-by	Other frequencies > 30 MHz and \leq 1 GHz	-57 dBm	100 kHz	Spurious emissions
	Frequencies > 1 GHz and < 26 GHz outside the exclusion band	-47 dBm	1 MHz	

4.3.2.2 Sensitivity

The OBU sensitivity is the minimum incident power P_{sens} referred to a loss-less isotropic antenna at the location of the OBU receive antenna that allows the OBU to receive DSRC frames with a BER of 10^{-6} or smaller.

The OBU sensitivity P_{sens} shall fulfil the following requirement:

$$P_{sens} \leq P_{D11b} = -43 \text{ dBm.}$$

4.3.2.3 Receiver selectivity

4.3.2.3.1 General

The manufacturer shall declare one of the OBU receiver selectivity classes specified in table 8 and table 9. Class 1 is a standard receiver. Class 2 is a receiver with improved performance level, beneficial for time critical applications and longer transmission ranges.

The OBU receiver is designed to work for the whole operational bandwidth of 20 MHz. The OBU shall be able to receive on all four 5 MHz channels simultaneously, since the OBU does not know which 5 MHz channel to receive before or during message transmission.

Taking this into account, the receiver spurious response rejection and the adjacent-channel rejection for the operational bandwidth are equivalent.

4.3.2.3.2 Receiver spurious response rejection and adjacent channel rejection

The spurious response rejection is a measure of the capability of the receiver to receive a wanted signal without exceeding a given degradation due to the presence of an unwanted input signal at any frequency which differs in frequency from the wanted signal by at least 20 MHz.

Since the operational bandwidth of the OBU is 20 MHz, the receiver spurious response rejection is in practice identical to the adjacent channel rejection. The adjacent channel rejection can be measured with the same measurement procedure when the unwanted signal is ± 20 MHz off the operational bandwidth centre.

The unwanted signal is considered to be an unmodulated carrier. The received wanted DSRC incident power level at the phase centre of the OBU antenna (see clause 4.3.3) is considered to be -37 dBm (6 dB above the OBU sensitivity level). For these considerations the power limit at the phase centre of the OBU antenna that does not degrade the BER to a value greater than 10^{-6} shall conform to the limit given in table 8 for the selected OBU receiver selectivity class.

Table 8: Receiver spurious response rejection and adjacent channel rejection

OBU receiver selectivity class	Receiver spurious response rejection
Class 1	-45 dBm
Class 2	-40 dBm

4.3.2.3.3 Receiver blocking

The receiver blocking is a measure of the capability of the receiver to receive a wanted signal without exceeding a given degradation due to the presence of an unwanted input signal at any frequency which differs in frequency from the wanted signal by at least 50 MHz.

The unwanted signal is considered to be an unmodulated carrier which differs in frequency from the wanted signal by ± 50 MHz, ± 100 MHz and ± 200 MHz.

The received wanted DSRC incident power level at the phase centre of the OBU antenna (see clause 4.3.3) is considered to be -37 dBm (6 dB above the OBU sensitivity level). For these considerations the power limit at the phase centre of the OBU antenna that does not degrade the BER to a value greater than 10^{-6} shall conform to the limit given in table 9 for the selected OBU receiver selectivity class.

Table 9: Receiver blocking

OBU receiver selectivity class	Receiver blocking
Class 1	-35 dBm
Class 2	-30 dBm

4.3.2.3.4 Co-channel rejection

The co-channel rejection is a measure of the capability of the receiver to receive a wanted signal without exceeding a given degradation due to the presence of an unwanted input signal within the 20 MHz operational bandwidth of the OBU.

The unwanted signal is considered to be an unmodulated carrier. The received wanted DSRC incident power level at the phase centre of the OBU antenna (see clause 4.3.3) is considered to be -37 dBm (6 dB above the OBU sensitivity level). For these considerations the power limit at the phase centre of the OBU antenna that does not degrade the BER to a value greater than 10^{-6} shall conform to the limit given in table 10 for the selected OBU receiver selectivity class.

Table 10: Receiver co-channel rejection

OBU receiver selectivity class	Receiver co-channel rejection
Class 1	-55 dBm
Class 2	-50 dBm

4.3.3 Antennas

All equipment antennas shall be LHCP according to parameters U5 and U5a in CEN EN 12253 [1].

An OBU may provide either none, one or more antenna connectors.

In case an OBU does not provide an antenna connector, then either one antenna for receiving and transmitting, or one antenna for receiving and one antenna for transmitting are implemented. In the first case, the phase centre of the OBU antenna is entitled M_c , see figure 1. In the latter case it is assumed that the two antennas are close to each other and point approximately to the same direction. The centre between these two antennas then is entitled M_c . For the purpose of easy reading of the present document, in what follows M_c is referred to as "phase centre of the OBU antenna".

The minimum operational direction of OBU receive and transmit antenna is characterized by a cone with opening angle θ around boresight as depicted in figure 1. The OBU shall provide specific properties inside the cone. The border of the cone itself is referred to as worst case direction. The directions M_0 through M_4 and the phase centre M_c of the OBU antenna are related to measurements described in the present document.

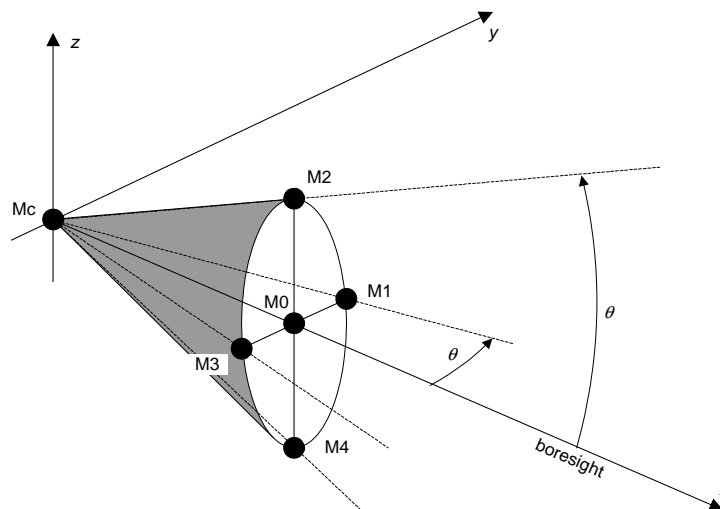

Figure 1: OBU antenna characteristic

The angle θ is used in the e.i.r.p. test of the present document.

A value of $\theta = 35^\circ$ is required for OBU minimum conversion gain and for OBU maximum single side band e.i.r.p. according to CEN EN 12253 [1].

5 Testing for compliance with technical requirements

5.1 Environmental conditions for testing

Tests defined in the present document shall be carried out at representative points within the boundary limits of the mandatory environmental profile specified in clause C.2.

Where technical performance varies subject to environmental conditions, tests shall be carried out under a sufficient variety of environmental conditions (within the boundary limits of the mandatory environmental profile) to give confidence of compliance for the affected technical requirements.

Other environmental profiles that may additionally be selected for testing are defined in clause C.3.

5.2 Interpretation of the measurement results

The interpretation of the results recorded in a test report for the measurements described in the present document shall be as follows:

- the measured value related to the corresponding limit will be used to decide whether an equipment meets the requirements of the present document;
- the value of the measurement uncertainty for the measurement of each parameter shall be included in the test report.

Recommended values for the maximum measurements uncertainty figures can be found in annex D.

5.3 Radio test suites

5.3.1 Transmitter parameters

5.3.1.1 Transmitter spectrum mask

5.3.1.1.1 General

If the EUT has an integrated antenna, radiated measurements shall be performed.

If the EUT has not an integrated antenna, conducted measurements shall be performed.

Basic requirements, test setups, and guidelines for measurements are provided in annex B.

Parameter descriptions and limits are provided in clause 4.3.1.1.

For this test, the incident signal power P_{inc} shall be adjusted such that the power measured in the test is maximized. A suitable value for P_{inc} is the value $P_{\text{inc,scan}}$ as evaluated in clause 5.3.1.2.

The centre frequencies $f_c = f_{\text{Tx}} + f_{\text{offset}}$ and the resolution bandwidth RBW of the RD shall be set for measurements in the sequence as indicated for the offset frequencies f_{offset} in table 11.

Table 11: Offset frequencies and RBW for testing OBU Tx spectrum mask

f_{offset} (MHz)			-1,5	+1,5	-2	+2	-3	+3	-3,5	+3,5			-6,5	+6,5	-7	+7
RBW	100 kHz										100 kHz					

5.3.1.1.2 Radiated measurements

The test procedure is as follows:

- 1) Prepare the test site according to clause B.1.6.5.1.
- 2) Switch on the monochromatic output signal of the MSS1, tune it to the carrier frequency f_{Tx} defined for channel 1 according to table 3 and clause 4.1.3.
- 3) Adjust the output power of the MSS1 such that the power P_{RSA} measured by the power meter PM1 amounts to:

$$P_{\text{RSA}} = P_{\text{inc}} \times G_{\text{RSA}} \times \left(1 - |\rho_{\text{RSA}}|^2 \right),$$

where P_{inc} , and ρ_{RSA} denote, respectively, the incident signal power as requested in clause 5.3.1.1.1, and the reflection coefficient at the connector of the RSA.

- 4) Replace the RSA by the EUT such that its phase centre M_c is as coincident with the axis of rotation of the turntable as possible. If the phase centre M_c of the OBU is unknown and no antenna is visible, the volume centre of the OBU shall be used instead. The boresight of the OBU antenna shall point towards the phase centre of the TA.
- 5) Set the RD to its CW mode, also called zero span mode of operation, where the instrument is not sweeping across a frequency band.
- 6) The EUT shall be operated with sub-carrier frequency f_s in a test mode such that it transmits the test signal TS1.
- 7) Select one of the offset frequencies f_{offset} from table 11. An absolute value of the offset frequency equal to the value of the actually used sub-carrier frequency f_s , e.g. $f_{\text{offset}} = \pm 1,5$ MHz or $f_{\text{offset}} = \pm 2,0$ MHz, is invalid for this test. If f_{offset} amounts to either ± 1 MHz or ± 4 MHz, proceed with step 8, otherwise proceed with step 13.

- 8) Set the centre frequency f_c of the RD to $f_c = f_{Tx} + f_{offset} - RBW / 2$ and select RBW according to table 11.
- 9) Measure the signal power P_1 from the RD and report this value together with the associated carrier frequency f_{Tx} and offset frequency f_{offset} .
- 10) Set the centre frequency f_c of the RD to $f_c = f_{Tx} + f_{offset} + RBW / 2$ and select RBW according to table 11.
- 11) Measure the signal power P_2 from the RD and report this value together with the associated carrier frequency f_{Tx} and offset frequency f_{offset} .
- 12) Determine the total signal power P_{tot} by summing up the two signal power values as $P_{tot} = P_1 + P_2$, and compute the power $P_{tot,dBm}$ in dBm as $P_{tot,dBm} = 10 \times \lg(P_{tot}/P_0)$. Report this value together with the associated carrier frequency f_{Tx} and offset frequency f_{offset} . Proceed with step 19.
- 13) Set the centre frequency f_c of the RD to its initial value $f_c = f_{Tx} + f_{offset} - 2 \times RBW$, select RBW according to table 11 and set the counter $i = 1$.
- 14) Measure the signal power P_i from the RD and report this value together with the associated carrier frequency f_{Tx} and offset frequency f_{offset} .
- 15) Increase the value of the counter by 1. When the counter equals 6, proceed with step 18, otherwise proceed with step 16.
- 16) Increase the centre frequency f_c of the RD by RBW and measure the signal power P_i from the RD and record its value together with the associated carrier frequency f_{Tx} and offset frequency f_{offset} in the test report.
- 17) Repeat step 15 and step 16.
- 18) Determine the total signal power P_{tot} by summing up five signal power values as $P_{tot} = P_1 + P_2 + P_3 + P_4 + P_5$ and compute the total power $P_{tot,dBm}$ in dBm as $P_{tot,dBm} = 10 \times \lg(P_{tot}/P_0)$. Report this value together with the associated carrier frequency f_{Tx} and offset frequency f_{offset} .
- 19) Repeat step 7 to step 19 until the whole sequence of offset frequencies listed in table 11 have been processed.
- 20) Repeat step 7 to step 19 once for the other sub-carrier frequency f_s .
- 21) Repeat step 1 to step 20 for the carrier frequency f_{Tx} defined for channel 4 according to table 3 and clause 4.1.3.
- 22) For a specific combination of carrier frequency f_{Tx} and offset frequency f_{offset} the maximum value of all P_{tot} reported for different sub-carrier frequencies f_s shall apply for the subsequent evaluation.
- 23) Replace the EUT by a LHCP TSA of gain G_{TSA} and reflection coefficient ρ_{TSA} at its connector suited for the range of carrier frequencies f_{Tx} listed in table 3 in such a way that its phase centre coincides with the one of the OBU transmitting antenna. If the measurement arrangement with one test antenna is used, the boresight of the TSA shall point towards the phase centre of the TTA. If the measurement arrangement with two test antennas is used, boresight of the TSA shall point towards position M_{centre} .
- 24) Connect the output of the TSA via the optional balun BLN, if required, of feed through attenuation ATN_{BLN} , and the FCCA1 of feed through attenuation ATN_{CA1} to a MSS2.
- 25) Tune the frequency of the MSS2's output signal to the same frequency $f_c = f_{Tx} + f_{offset}$ as was used for the RD, where f_{Tx} is according to clause 4.1.3 and f_{offset} shall be according to table 11.
- 26) Rotate the TSA through 360° until the maximum level is detected by the RD.

- 27) Adjust the output signal level P_{MSS2} of the MSS2 until the level, measured on the RD, becomes identical to P_{tot} as reported in step 22 at the same combination of carrier frequency f_{Tx} and offset frequency f_{offset} . This output signal level P_{MSS2} from the MSS2 shall be reported together with the associated carrier frequency f_{Tx} and offset frequency f_{offset} .
- 28) Repeat step 25 to step 27 for all remaining combinations of carrier frequencies f_{Tx} and offset frequencies f_{offset} .
- 29) The TSM at this combination of carrier frequency f_{Tx} and offset frequency f_{offset} , expressed as an e.i.r.p. of the EUT shall be calculated by:

$$EIRP_{\text{TSM}} = \frac{P_{\text{MSS2}} \times G_{\text{TSA}} \times \left(1 - |\rho_{\text{TSA}}|^2\right)}{ATN_{\text{CA1}} \times ATN_{\text{BLN}}},$$

where all the parameters in the above formula are related to the corresponding measurement frequencies. The result shall be reported together with the associated carrier frequency f_{Tx} and offset frequency f_{offset} . It shall not exceed the limit stated in clause 4.3.1.1.

5.3.1.1.3 Conducted measurements

The test procedure is as follows:

- 1) Prepare the test site according to clause B.1.5.4.1.
- 2) Tune the frequency of the MSS1's output signal to the carrier frequency f_{Tx} defined for channel 1 according to table 3 and clause 4.1.3.
- 3) Replace the EUT by a power meter PM1.
- 4) Adjust the output power of the MSS1 such that the power measured by PM1 matches the incident power as indicated in clause 5.3.1.1.1 increased by the stated OBU receive antenna gain.
- 5) Replace PM1 by the EUT.
- 6) Set the RD to its CW mode, also called zero span mode of operation, where the instrument is not sweeping across a frequency band.
- 7) The EUT shall be operated with sub-carrier frequency f_s in a test mode such that it transmits the test signal TS1.
- 8) Select one of the offset frequencies f_{offset} from table 11. An absolute value of the offset frequency equal to the value of the actually used sub-carrier frequency f_s , e.g. $f_{\text{offset}} = \pm 1,5$ MHz or $f_{\text{offset}} = \pm 2,0$ MHz, is invalid for this test. If f_{offset} amounts to either ± 1 MHz or ± 4 MHz, proceed with step 9, otherwise proceed with step 14.
- 9) Set the centre frequency f_c of the RD to $f_c = f_{\text{Tx}} + f_{\text{offset}} - RBW / 2$ and select RBW according to table 11.
- 10) Measure the signal power P_1 from the RD taking into account all losses the signal suffers between the output connector of the EUT and the input connector of the RD and report this value together with the associated carrier frequency f_{Tx} and offset frequency f_{offset} .
- 11) Set the centre frequency f_c of the RD to $f_c = f_{\text{Tx}} + f_{\text{offset}} + RBW / 2$ and select RBW according to table 11.
- 12) Measure the signal power P_2 from the RD taking into account all losses the signal suffers between the output connector of the EUT and the input connector of the RD and report this value together with the associated carrier frequency f_{Tx} and offset frequency f_{offset} .

- 13) Determine the total signal power P_{tot} by summing up the two signal power values as $P_{\text{tot}} = P_1 + P_2$, and compute the power $P_{\text{tot,dBm}}$ in dBm as $P_{\text{tot,dBm}} = 10 \times \lg(P_{\text{tot}}/P_0)$. Report this value together with the associated carrier frequency f_{Tx} and offset frequency f_{offset} . Proceed with step 20.
- 14) Set the centre frequency f_c of the RD to its initial value $f_c = f_{\text{Tx}} + f_{\text{offset}} - 2 \times \text{RBW}$, select RBW according to table 11 and set the counter $i = 1$.
- 15) Rotate the EUT through 360° in the horizontal plane until signal power detected by the RD reaches its maximum value P_i . Record this value together with the associated carrier frequency f_{Tx} and offset frequency f_{offset} in the test report.
- 16) Increase the value of the counter by 1. When the counter equals 6, proceed with step 19, otherwise proceed with step 17.
- 17) Increase the centre frequency f_c of the RD by RBW and measure the signal power P_i from the RD and record its value together with the associated carrier frequency f_{Tx} and offset frequency f_{offset} in the test report.
- 18) Repeat step 16 and step 17.
- 19) Determine the total signal power P_{tot} by summing up five signal power values as $P_{\text{tot}} = P_1 + P_2 + P_3 + P_4 + P_5$ and compute the total power $P_{\text{tot,dBm}}$ in dBm as $P_{\text{tot,dBm}} = 10 \times \lg(P_{\text{tot}}/P_0)$. Report this value together with the associated carrier frequency f_{Tx} and offset frequency f_{offset} .
- 20) Repeat step 8 to step 19 until the whole sequence of offset frequencies listed in table 11 have been processed.
- 21) Repeat step 8 to step 20 once for the other sub-carrier frequency f_s .
- 22) Repeat step 1 to step 21 for the carrier frequency f_{Tx} defined for channel 4 according to table 3 and clause 4.1.3.
- 23) For a specific combination of carrier frequency f_{Tx} and offset frequency f_{offset} the maximum value of all P_{tot} reported for different sub-carrier frequencies f_s shall apply for the subsequent evaluation.
- 24) Compute the signal power P_{TSM} associated with each carrier frequency f_{Tx} and each offset frequency f_{offset} from the corresponding signal power values P_{tot} considering all losses within the signal path between the RD and the connector of the OBU's transmitting antenna. Record all values of P_{TSM} together with the associated carrier frequency f_{Tx} and offset frequency f_{offset} in the test report.
- 25) The TSM for each combination of carrier frequency f_{Tx} and offset frequency f_{offset} , expressed as an e.i.r.p. of the EUT shall be calculated by:

$$EIRP_{\text{TSM}} = P_{\text{TSM}} \times G_{\text{OBU,Tx}}$$

where $G_{\text{OBU,Tx}}$ denotes the maximum gain of the OBU transmitting antenna. It shall be understood that all parameter values are taken at the corresponding frequency $f = f_{\text{Tx}} + f_{\text{offset}}$. The result shall be reported together with the associated carrier frequency f_{Tx} and offset frequency f_{offset} . None of these values shall exceed the limit stated in clause 4.3.1.1.

5.3.1.2 Maximum equivalent isotropically radiated power

5.3.1.2.1 General

If the EUT has an integrated antenna, radiated measurements shall be performed.

If the EUT has not an integrated antenna, conducted measurements shall be performed.

Basic requirements, test setups, and guidelines for measurements are provided in annex B.

Parameter descriptions and limits are provided in clause 4.3.1.2.

Measurement shall be conducted with the reference incident power P_{inc} set equal to the maximum incident signal power P_{D11a} according to parameter D11a of CEN EN 12253 [1], see table 12.

In order to identify the incident signal power P_{inc} at which maximum e.i.r.p. occurs, a scanning procedure shall be performed. The measurement shall be repeated at this value $P_{\text{inc}} = P_{\text{inc,scan}}$ of the incident signal power and the result shall be reported together with this incident signal power.

The conversion gain shall be adjusted to the maximum possible value, if applicable.

Table 12: OBU power limit for communication (upper) for Sets A and B

Power limit for communication (upper) P_{D11a} according to parameter D11a of CEN EN 12253 [1]	
Set A	Set B
-17 dBm	-24 dBm

5.3.1.2.2 Radiated measurement

The test procedure is as follows:

- 1) Prepare the test site according to clause B.1.6.5.1. The initial alignment of the EUT as needed in step 4 shall be according to M0 in figure 1, i.e. the boresight of the OBU antenna shall point towards the phase centre of the TA.
- 2) Switch on the monochromatic output signal of the MSS1, tune it to the carrier frequency f_{Tx} defined for channel 1 according to table 3 and clause 4.1.3.
- 3) Adjust the output power of the MSS1 such that the power P_{RSA} measured by the power meter PM1 amounts to:

$$P_{\text{RSA}} = P_{\text{inc}} \times G_{\text{RSA}} \times \left(1 - |\rho_{\text{RSA}}|^2 \right),$$

where P_{inc} , and ρ_{RSA} denote, respectively, the reference incident signal power as requested in table 12, and the reflection coefficient at the connector of the RSA.

- 4) Replace the RSA by the EUT such that its phase centre M_c is as coincident with the axis of rotation of the turntable as possible. If the phase centre M_c of the EUT is unknown and no antenna is visible, the volume centre of the EUT shall be used instead. Align the OBU's boresight as required.
- 5) Set the EUT to a test mode such that it re-transmits test signal TS2 with sub-carrier frequency f_s .
- 6) Measure the larger of the power levels P_{max} within the two side bands by the RD using a RBW of 100 kHz and report this value of P_{max} together with the orientation of the EUT M_i , $i = [0..4]$, and the values of f_s and f_{Tx} .
- 7) Repeat step 6 for the other value of the sub-carrier frequency f_s .
- 8) Repeat step 3 to step 7 for the carrier frequency f_{Tx} defined for channel 4 according to table 3 and clause 4.1.3.
- 9) In case of a Set B EUT proceed with step 10, otherwise continue with step 11.
- 10) Repeat step 1 to step 8 for all remaining OBU orientations as indicated by M1, M2, M3, and M4 in figure 1 in order to measure the CEN parameter U4a.
- 11) Replace the EUT by a LHCP TSA of gain G_{TSA} and reflection coefficient ρ_{TSA} at its connector suited for the range of carrier frequencies f_{Tx} listed in table 3 in such a way that its phase centre coincides with the one of the OBU transmitting antenna. If the measurement arrangement with one test antenna is used, the boresight of the TSA shall point towards the phase centre of the TTA. If the measurement arrangement with two test antennas is used, boresight of the TSA shall point towards position M_{centre} .

- 12) Connect the output of the TSA via the optional balun BLN, if required, of feed through attenuation ATN_{BLN} , and the FCCA1 of feed through attenuation ATN_{CA1} to a MSS2 that shall be tuned to the frequency which is the sum of the carrier frequency f_{Tx} and the (signed) sub-carrier frequency f_s reported as a set together with the OBU orientation in step 6.
- 13) Adjust the output signal level of the MSS2 until the level, measured on the RD, becomes identical to P_{max} recorded in step 6 for this set of values of f_{Tx} , f_s and Mi. This output signal level P_{MSS2} from the MSS2 shall be reported.
- 14) The e.i.r.p. of the EUT shall be calculated by:

$$EIRP_{OBU} = \frac{P_{MSS2} \times G_{TSA} \times \left(1 - |\rho_{TSA}|^2\right)}{ATN_{CA1} \times ATN_{BLN}},$$

where all the parameters in the above formula are related to the corresponding measurement frequencies. The result shall not exceed the limit stated in table 5.

- 15) Repeat step 12 to step 14 for all remaining sets of values of f_{Tx} , f_s and Mi.

5.3.1.2.3 Conducted measurement

The test procedure is as follows:

- 1) Prepare the test site according to clause B.1.5.4.1.
- 2) Tune the frequency of the MSS1's output signal to the carrier frequencies f_{Tx} defined for channel 1 according to table 3 and clause 4.1.3.
- 3) Replace the EUT receiver by a power meter PM1.
- 4) Adjust the output power of the MSS1 such that the power measured by PM1 matches the reference incident power as indicated in table 12 increased by the stated OBU receive antenna gain.
- 5) Replace PM1 by the EUT.
- 6) Set the EUT to a test mode such that it re-transmits test signal TS2 with sub-carrier frequency f_s .
- 7) Measure the signal power within each of the two side bands by the RD using a RBW of 100 kHz and compute the corresponding signal power at the connector of the OBU's transmitting antenna taking into account all losses the signal suffers between the output connector of the EUT and the input connector of the RD. Report the larger of these two values, the power P_{max} .
- 8) Repeat step 7 for the other sub-carrier frequency.
- 9) Repeat step 3 to step 8 for the carrier frequency f_{Tx} defined for channel 4 according to table 3 and clause 4.1.3.
- 10) Compute the corresponding e.i.r.p. for all the power levels P_{max} recorded within step 7 into the test report using the equation:

$$EIRP_{OBU} = P_{max} \times G_{OBU,Tx}(Mi)$$

where $G_{OBU,Tx}(Mi)$ denotes the gain of the stated OBU transmitting antenna in the directions M0 through M5 as indicated in figure 1. None of the results shall exceed the limit stated in table 5. In case of a Set A EUT only direction M0 is applicable.

5.3.1.3 Transmitter frequency error

5.3.1.3.1 General

If the EUT has an integrated antenna, radiated measurements shall be performed.

If the EUT has not an integrated antenna, conducted measurements shall be performed.

Basic requirements, test setups, and guidelines for measurements are provided in annex B.

Parameter descriptions and limits are provided in clause 4.3.1.3.

5.3.1.3.2 Radiated measurements

The test procedure is as follows:

- 1) Prepare the test site according to clause B.1.6.5.1.
- 2) Switch on the monochromatic output signal of the MSS1, tune it to the carrier frequencies f_{Tx} defined for channel 1 according to table 3 and clause 4.1.3 and adjust its output power to a level that produces an incident power at the location of the CA within the dynamic range of the EUT.
- 3) Replace the RSA by the EUT such that its phase centre M_c is as coincident with the axis of rotation of the turntable as possible. If the phase centre M_c of the EUT is unknown and no antenna is visible, the volume centre of the EUT shall be used instead. The boresight of the OBU antenna shall point towards the phase centre of the TA.
- 4) Set the RBW of the RD used for frequency measurements to ≤ 1 kHz.
- 5) Set the EUT to a test mode with test signal TS2 and with sub-carrier frequency f_s .
- 6) Connect temporarily the output of the MSS1 to the RD and measure and report the actual carrier frequency $f_{Tx,actual}$ of the downlink radio signal. Reconnect the output of the MSS1.
- 7) Measure with the RD the actual centre frequency f_{ObuTx} of the uplink radio signal in one of the two side bands as convenient.
- 8) Calculate the actual sub-carrier frequency error $\Delta f_s = \frac{|f_{ObuTx} - f_{Tx,actual}|}{f_s} - 1$ and convert the value to percent.
The actual value shall not exceed the limit stated in clause 4.3.1.3.
- 9) Repeat step 6 to step 8 for the other sub-carrier frequency f_s .

5.3.1.3.3 Conducted measurements

The test procedure is as follows:

- 1) Prepare the test site according to clause B.1.5.4.1.
- 2) Tune the frequency of the MSS1's output signal to the carrier frequencies f_{Tx} defined for channel 1 according to table 3 and clause 4.1.3.
- 3) Replace the EUT by a power meter PM1.
- 4) Adjust the output power of the MSS1 such that the power measured by PM1 is within the dynamic range of the EUT reduced by the stated OBU receive antenna gain.
- 5) Replace PM1 by the EUT.
- 6) Set the RBW of the RD used for frequency measurements to ≤ 1 kHz.
- 7) Set the EUT to a test mode with test signal TS2 and with sub-carrier frequency f_s .
- 8) Connect temporarily the output of the MSS1 to the RD and measure and report the actual carrier frequency $f_{Tx,actual}$ of the downlink radio signal. Reconnect the output of the MSS1.
- 9) Measure with the RD the actual centre frequency f_{ObuTx} of the uplink radio signal in one of the two side bands as convenient.

- 10) Calculate the actual sub-carrier frequency error $\Delta f_s = \frac{|f_{\text{ObuTx}} - f_{\text{Tx, actual}}|}{f_s} - 1$ and convert the value to percent.

The actual value shall not exceed the limit stated in clause 4.3.1.3.

- 11) Repeat step 8 to step 11 for the other sub-carrier frequency f_s .

5.3.1.4 Transmitter unwanted emissions

5.3.1.4.1 General

The test shall be performed either in an anechoic chamber or in an open area test site. The setup is illustrated in clause B.1.6.5.3 in figure B.10 and figure B.11.

The test shall be performed with radiated measurements within all frequency bands as referred to as "operating mode" in table 6 outside the exclusion band stated in clause 4.3.1.4. If the EUT has not an integrated antenna, then the antenna for the intended use of the EUT shall be used.

Basic requirements, test setups, and guidelines for measurements are provided in annex B.

Parameter descriptions and limits are provided in clause 4.3.1.4.

For this test, the incident signal power P_{inc} shall be adjusted such that the measured power level at the RTA is at its maximum. A suitable value for P_{inc} is the value $P_{\text{inc,scan}}$ as evaluated in clause 5.3.1.2.

5.3.1.4.2 Radiated measurement

With reference to figure B.10 and figure B.11 in clause B.1.6.5.3, the following test procedure shall apply for simultaneous spurious and out-of-band emissions radiated by the OBU transmit antenna.

- 1) The test shall be setup as specified in clause B.1.6.5.3.
- 2) Replace the EUT by the TSA such that their phase centres, and boresights coincide, respectively. Boresight of the TSA shall point towards the phase centre of the RTA. The TSA shall be connected to a MSS2 using ferrited coaxial cables. Polarization of the TSA shall match the one of the RTA.
- 3) Move the turntable to its initial angular position MT0 according to figure B.11.
- 4) Table 6 in clause 4.3.1.4 specifies the maximum spurious and out-of-band emissions for the operating mode as function of frequency. Adjust the output power of the MSS2 such that the e.i.r.p. of the TSA is equal to these limits for each measurement frequency and measure the power at the RD with a RBW equal to the reference bandwidth as indicated in table 6. Report the power levels as a function of frequency in Watt measured at the RD for further usage as a limit line.
- 5) The TTA shall be connected to a MSS1 using a FCCA.
- 6) Switch on the monochromatic output signal of the MSS1, tune it to the carrier frequency f_{Tx} defined for channel 1 according to table 3 and clause 4.1.3.
- 7) The LHCP RSA of gain G_{RSA} shall be suited for the range of carrier frequencies f_{Tx} listed in table 3. Replace the TSA by the LHCP RSA such that their phase centres, and boresights coincide, respectively. The output of the RSA shall be connected directly to the power sensor of power meter PM1 that shall be set to the frequency of the monochromatic signal under consideration. Adjust the output power of the MSS1 such that the power P_{RSA} measured by the power meter PM1 amounts to:

$$P_{\text{RSA}} = P_{\text{inc}} \times G_{\text{RSA}} \times \left(1 - |\rho_{\text{RSA}}|^2\right),$$

where P_{inc} , and ρ_{RSA} denote, respectively, the incident signal power as requested in clause 5.3.1.4.1, and the reflection coefficient at the connector of the RSA.

- 8) Repeat step 1, which actually replaces the RSA by the EUT.

- 9) Select the first frequency band to be tested according to table 6.
- 10) Set the EUT to a test mode with test signal TS1 and with sub-carrier frequency f_s .
- 11) Move the turntable to its initial angular position MT0 according to figure B.11.
- 12) The resolution bandwidth of the RD used to measure signal power shall be set equal to the reference bandwidth as indicated in table 6. Measure the power spectrum P_{pol} , i.e. $P_{pol} = P_v$ in case of vertical polarized RTA and $P_{pol} = P_h$ in case of horizontal polarized RTA, received by the RD and report the result for further processing in step 18. Repeat step 12 for all other angular positions MT1, MT2, MT3 of the turntable according to figure B.11.
- 13) Repeat step 16 and step 17 once for the other sub-carrier frequency f_s .
- 14) Repeat step 15 to step 18 for the carrier frequency f_{Tx} defined for channel 4 according to table 3 and clause 4.1.3.
- 15) Repeat step 11 to step 14 for all frequency bands indicated in clause 4.3.1.4, see there table 6 for the operating mode of the EUT and the exclusion band.
- 16) Rotate the RTA such that it is horizontally polarized, without changing position of its phase centre and boresight orientation.
- 17) Repeat step 11 to step 15.
- 18) Compute the resulting power $P_{spurious} = P_v + P_h$ and compare it with the limit line. If the power $P_{spurious}$ exceeds the limit evaluated in step 9 for any frequency, the test failed.

5.3.2 Receiver parameters

5.3.2.1 Receiver unwanted emissions in the spurious domain

5.3.2.1.1 General

The test shall be performed with radiated measurements within all frequency bands as referred to as "stand-by state" in table 7 outside the exclusion band stated in clause 4.3.1.4. Conducted measurements are not possible.

The test shall be performed either in an anechoic chamber or in an open area test site. The setup is illustrated in figure B.10 and figure B.11 in clause B.1.6.5.3. If the EUT has not an integrated antenna, then the antenna for the intended use of the EUT shall be used.

Basic requirements, test setups, and guidelines for measurements are provided in annex B.

Parameter descriptions and limits are provided in clause 4.3.2.1.

5.3.2.1.2 Radiated measurement

With reference to figure B.10 and figure B.11, the test procedure for spurious and out-of-band emissions according to clause 5.3.1.4 shall apply with the following modifications:

- 1) There shall be no TTA and no MSS1. Thus, statements on the carrier frequency f_{Tx} shall not apply.
- 2) There shall be no RSA.
- 3) The EUT shall never transmit. Thus, statements on sub-carrier frequency f_s shall not apply.
- 4) The EUT shall never be in the sleep mode.
- 5) The applicable limits and resolution band widths for the "stand-by mode" are indicated in table 7.

5.3.2.2 Sensitivity

5.3.2.2.1 General

If the EUT has an integrated antenna, radiated measurements shall be performed.

If the EUT has not an integrated antenna, conducted measurements shall be performed.

Detailed specifications for each measurement setup can be found in annex B (specific references are given in each test description).

Parameter descriptions and limits are provided in clause 4.3.2.2.

The description below assumes that an OBU is used to receive down-link signals and to generate up-link signals, both of type TM1. The test can be performed accordingly based on laboratory instruments, i.e. an RSU simulator, to generate down-link signals of type TS1 and messages of type TM1 and to receive and evaluate up-link signals of type TM1.

The reference signal power limit P_{ref} for the sensitivity measurements is given by the sensitivity limit P_{D11b} (see clause 4.3.2.2):

$$P_{\text{ref}} = P_{\text{D11b}}.$$

5.3.2.2.2 Radiated measurements

The following procedural step shall apply:

- 1) Prepare the test site according to clause B.1.6.5.2.
- 2) The boresight of the EUT antenna shall point towards the phase centre of the RTA.
- 3) Set the SMS1 such that it continuously transmits test signal TS1.
- 4) Set the carrier frequency f_{Tx} of SMS1 defined for channel 1 according to table 3 and clause 4.1.3.
- 5) Set the modulation index of the signal transmitted by the SMS1 to 0,5 or to the smallest possible value within the allowed range of 0,5 to 0,9 supported by the SMS1.
- 6) Replace the EUT receiver by a RSA of gain G_{RSA} such that their phase centres and boresights coincide. Connect the RSA to a power meter PM1.
- 7) Adjust the output signal power of the SMS1 such that the signal power indicated by the power meter PM1 amounts to:

$$P_{\text{RSA}} = P_{\text{ref}} \times G_{\text{RSA}} \times \left(1 - |\rho_{\text{RSA}}|^2 \right),$$

where ρ_{RSA} denotes the reflection coefficient at the connector of the RSA.

- 8) Replace RSA by the EUT receiver.
- 9) Measure BER of the EUT receiver according to clause B.4. If the BER is greater than 10^{-6} the test failed.
- 10) Repeat step 6 to step 9 for the carrier frequency f_{Tx} defined for channel 4 according to table 3 and clause 4.1.3.

5.3.2.2.3 Conducted measurements

The following procedural step shall apply:

- 1) Prepare the test site according to clause B.1.5.4.2.
- 2) Set the correction gain G_{corr} equal to the boresight gain of the stated EUT receive antenna.
- 3) Set the SMS1 such that it continuously transmits test signal TS1.

- 4) Set the carrier frequency f_{Tx} of SMS1 defined for channel 1 according to table 3 and clause 4.1.3.
- 5) Set the modulation index of the signal transmitted by the SMS1 to 0,5 or to the smallest possible value within the allowed range of 0,5 to 0,9 supported by the SMS1.
- 6) Replace the EUT receiver by a power meter PM1.
- 7) Adjust the output signal power of the SMS1 such that the signal power level indicated by the power meter PM1 equals $P_{ref,dBm}$ plus the gain G_{corr} in dB.
- 8) Replace PM1 by the EUT receiver.
- 9) Measure BER of the EUT receiver according to clause B.4. If the BER is greater than 10^{-6} the test failed.
- 10) Repeat step 6 to step 9 for the carrier frequency f_{Tx} defined for channel 4 according to table 3 and clause 4.1.3.

5.3.2.3 Receiver selectivity

5.3.2.3.1 General

This test shall be performed with radiated measurements. If the EUT has not an integrated antenna, then the antenna for the intended use of the EUT shall be used.

Detailed specifications for each measurement setup can be found in annex B (specific references are given in each test description).

Parameter descriptions and limits are provided in clause 4.3.2.3.

The description in clause 5.3.2.3.3 assumes that an EUT is used to receive downlink signals and to generate uplink signals, both of type TM1. The test can be performed accordingly based on laboratory instruments, i.e. an RSU simulator, to generate downlink signals of type TS1 and messages of type TM1 and to receive and evaluate uplink signals of type TM1.

5.3.2.3.2 Unwanted signal characteristics

The receiver selectivity measurement shall be performed with an unmodulated single carrier unwanted signal with frequencies f_u differing by ± 20 MHz, ± 50 MHz, ± 100 MHz and ± 200 MHz from the selected DSRC channel, in addition for the adjacent channel rejection measurement f_u shall be 5 825 MHz and 5 785 MHz (which is ± 20 MHz from the centre of the operational band of the OBU), and for the co-channel rejection measurement f_u shall be 5 802,5 MHz and 5 807,5 MHz. The power level of the unwanted signal shall be at the limits specified in clause 4.3.2.3 for the respective measurement.

The representative frequencies f_u of the unwanted signal and the DSRC channel for testing shall be stated in the test report.

NOTE: The manufacturer may extend the test in order to determine the actual value of the immunity against other services.

5.3.2.3.3 Measurement of receiver selectivity in OBU boresight

- 1) Depending on the antenna connector of the RSU, set up the measurement arrangement as detailed in clause B.1.6.5.4.
- 2) Replace the EUT by a LHCP RTA, orientated with its boresight towards M_{centre} and connect a power meter PM1 to it.
- 3) Mute the RSU signal.
- 4) Configure the ASG to transmit the unwanted signal waveform specified in clause 5.3.2.3.2.

- 5) Determine the offset between the power setting at the ASG and the power level measured at the LHCP RTA, including 3 dB for the LP to LHCP transformation, for the frequencies f_u used for the measurement. This offset should equal the offset between the ASG power setting and the incident power level received by a hypothetical LP loss-less isotropic antenna at the location of the OBU antenna.
- 6) Mute the ASG signal.
- 7) Set the RSU to the mode that it transmits an unmodulated carrier.
- 8) Set the RSU output power to its maximum allowed value.
- 9) Adjust AT1 so that the incident power level received by a hypothetical LHCP loss-less isotropic antenna at the location of the OBU antenna equals -37 dBm.
- 10) Put the EUT back in place.
- 11) Set the modulation index of the RSU to any convenient value, if it is adjustable.
- 12) Set RSU and EUT to a mode that they are able to process test messages TM1.
- 13) Set the RSU to a mode such that the EUT shall use the lower sub-carrier frequency f_s .
- 14) Set the RSU carrier frequency f_{TX} to channel 1 as specified in table 3, the unwanted signal frequency to a value that differs +20 MHz from f_{TX} , and the unwanted signal power to the level specified in table 8 for the selected OBU receiver selectivity class.
- 15) Configure the ASG to transmit an unmodulated carrier, taking the offset determined in step 5 into account.
- 16) Measure the BER of the EUT according to clause B.4. If the BER is greater than the value specified in clause 4.3.2.3.2 the test failed.
- 17) Repeat step 16 with an unwanted signal frequency f_u with -20 MHz difference to f_{TX} , and with f_u set to 5 785 MHz and 5 825 MHz.
- 18) Set the unwanted signal frequency to a value that differs + 50 MHz from f_{TX} , and the unwanted signal power to the level specified in table 9 for the selected OBU receiver selectivity class.
- 19) Configure the ASG to transmit an unmodulated carrier, taking the offset determined in step 5 into account.
- 20) Measure the BER of the EUT according to clause B.4. If the BER is greater than the value specified in clause 4.3.2.3.3 the test failed.
- 21) Repeat step 20 with the unwanted signal frequencies f_u with - 50 MHz, ± 100 MHz and ± 200 MHz difference to f_{TX} .
- 22) Set the unwanted signal frequency to 5 802,5 MHz, and the unwanted signal power to the level specified in table 10 for the selected OBU receiver selectivity class.
- 23) Configure the ASG to transmit an unmodulated carrier, taking the offset determined in step 5 into account.
- 24) Measure the BER of the EUT according to clause B.4. If the BER is greater than the value specified in clause 4.3.2.3.4 the test failed.
- 25) Repeat step 24 with the unwanted signal frequency $f_u = 5 807,5$ MHz.
- 26) Repeat step 14 to step 25 with the RSU carrier frequency f_{TX} of channel 4 in accordance with table 3.
- 27) Set the RSU to a mode such that the EUT shall use the upper sub-carrier frequency f_s .
- 28) Repeat step 14 to step 26.

Annex A (informative): Relationship between the present document and the essential requirements of Directive 2014/53/EU

The present document has been prepared under the Commission's standardisation request C(2015) 5376 final [i.3] to provide one voluntary means of conforming to the essential requirements of Directive 2014/53/EU on the harmonisation of the laws of the Member States relating to the making available on the market of radio equipment and repealing Directive 1999/5/EC [i.2].

Once the present document is cited in the Official Journal of the European Union under that Directive, compliance with the normative clauses of the present document given in table A.1 confers, within the limits of the scope of the present document, a presumption of conformity with the corresponding essential requirements of that Directive and associated EFTA regulations.

Table A.1: Relationship between the present document and the essential requirements of Directive 2014/53/EU

Harmonised Standard ETSI EN 300 674-2-2					
Requirement				Requirement Conditionality	
No	Description	Essential requirements of Directive	Clause(s) of the present document	U/C	Condition
1	Maximum equivalent isotropically radiated power	3.2	4.3.1.2	U	
2	Transmitter frequency error	3.2	4.3.1.3	U	
3	Transmitter spectrum mask	3.2	4.3.1.1	U	
4	Transmitter unwanted emissions	3.2	4.3.1.4	U	
5	Receiver unwanted emissions in the spurious domain	3.2	4.3.2.1	U	
6	Sensitivity	3.2	4.3.2.2	U	
7	Receiver selectivity	3.2	4.3.2.3	U	

Key to columns:

Requirement:

No A unique identifier for one row of the table which may be used to identify a requirement.

Description A textual reference to the requirement.

Essential requirements of Directive

Identification of article(s) defining the requirement in the Directive.

Clause(s) of the present document

Identification of clause(s) defining the requirement in the present document unless another document is referenced explicitly.

Requirement Conditionality:

U/C Indicates whether the requirement is unconditionally applicable (U) or is conditional upon the manufacturer's claimed functionality of the equipment (C).

Condition Explains the conditions when the requirement is or is not applicable for a requirement which is classified "conditional".

Presumption of conformity stays valid only as long as a reference to the present document is maintained in the list published in the Official Journal of the European Union. Users of the present document should consult frequently the latest list published in the Official Journal of the European Union.

Other Union legislation may be applicable to the product(s) falling within the scope of the present document.

Annex B (normative): Basics on testing

B.1 General conditions

B.1.1 Thermal balance

Before measurements are made the equipment shall have reached thermal balance in the test chamber.

The equipment shall be switched off during the temperature stabilizing period.

In the case of equipment containing temperature stabilization circuits designed to operate continuously, the temperature stabilization circuits shall be switched on for a time period as declared by the manufacturer such that thermal balance has been obtained, and the equipment shall then meet the specified requirements.

B.1.2 Test signals

The following test signals and test messages are defined:

Table B.1: Test signals and messages

Test signal/message	Description
Test Messages (TM1)	DSRC communication sequence starting with an initialization phase conform to ISO 14906 [2], clause 6.2 followed by successive ECHO commands conform to ISO 14906 [2], clause 7.2.17.
Test Signal (TS1)	Properly modulated and coded DSRC signal where the data is a continuously repeated maximum length pseudo-random sequence generated by a linear feedback shift register. The period of the pseudo-random sequence shall be 511 bits.
Test Signal (TS2)	Continuous DSRC uplink signal with unmodulated sub-carrier. The sub-carrier frequency shall be settable to $f_s = 1,5$ MHz and $f_s = 2,0$ MHz, respectively.

Data coding and bit rates in downlink and uplink shall be according to parameters D7, U7 and D8, D8a, U8, U8a of CEN EN 12253 [1], respectively.

B.1.3 Test sites

B.1.3.1 Shielded anechoic chamber

A typical anechoic chamber is shown in figure B.1. This type of test chamber attempts to simulate free space conditions.

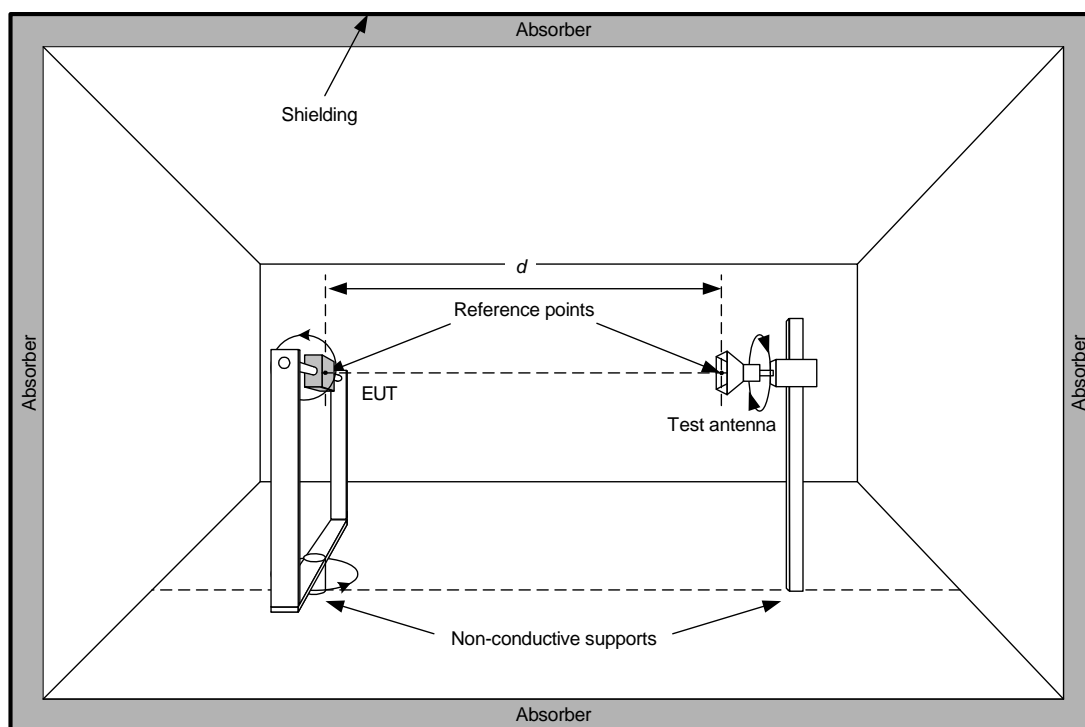

Figure B.1: Typical anechoic chamber

The chamber contains suitable antenna supports on both ends.

The supports carrying the test antenna and EUT shall be made of a non-permeable material featuring a low value of its relative permittivity.

The anechoic chamber shall be shielded. Internal walls, floor and ceiling shall be covered with radio absorbing material. The shielding and return loss for perpendicular wave incidence versus frequency as detailed in figure B.2 shall be met by anechoic chambers used to perform tests.

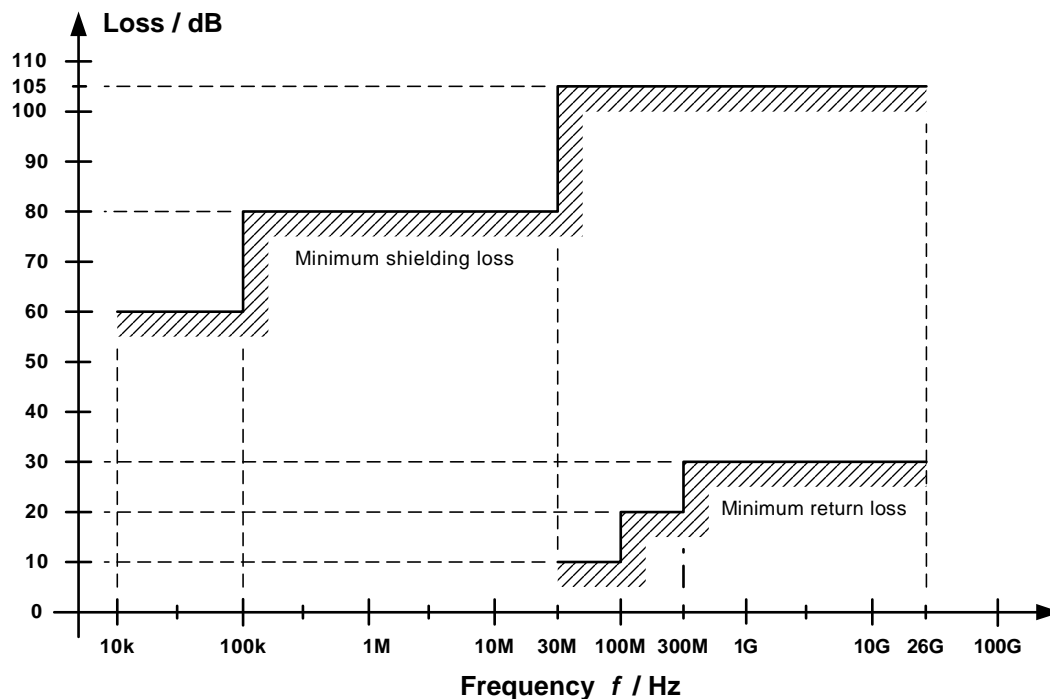

Figure B.2: Minimal shielding and return loss for shielded anechoic chambers

Both absolute and relative measurements can be performed in an anechoic chamber. Where absolute measurements are to be carried out the chamber shall be verified.

The shielded anechoic chamber test site shall be suitable for the frequency range being applicable.

NOTE: Information on uncertainty contributions, and verification procedures are detailed in clause 5 and clause 6, respectively, of ETSI TR 102 273-2 [i.7].

B.1.3.2 Open area test site

The open area test site shall be according to ETSI TS 103 052 [i.1], clause 5.1.

B.1.3.3 Test fixture

A test fixture is a device that allows for conducted measurements of an EUT that does not provide antenna connectors itself. The EUT can be either an OBU or a RSU. A test fixture contains a RF connector featuring a characteristic impedance of $50\ \Omega$, subsequently called $50\ \Omega$ RF connector, and a device for electromagnetic coupling to the EUT. It incorporates a means for repeatable positioning of the EUT. Figure B.3 illustrates a typical test fixture.

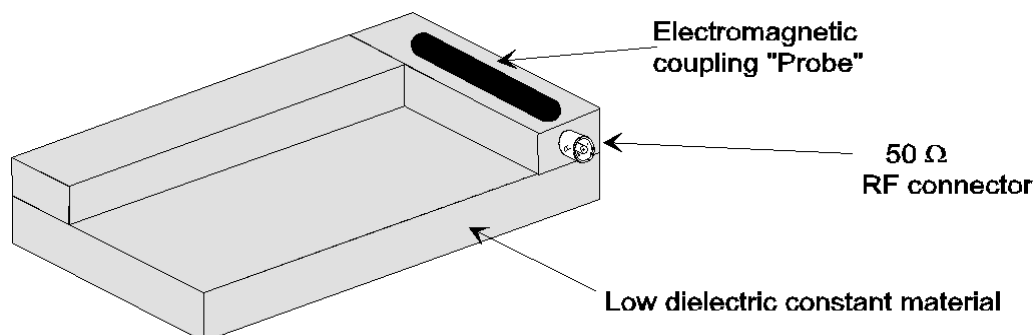

Figure B.3: Typical test fixture

The coupling device usually comprises a small antenna that is placed, physically and electrically, close to the EUT. This coupling device is used for sampling or generating the test fields when the EUT is undergoing testing. Figure B.4 illustrates an EUT mounted on a test fixture.

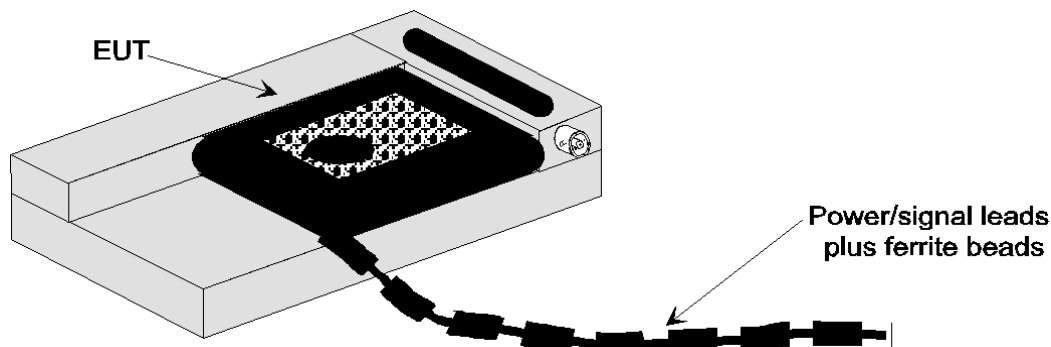

Figure B.4: EUT mounted in a typical test fixture

The entire assembly of test fixture plus EUT is generally compact and it can be regarded as a EUT with antenna connector. Its compactness enables the whole assembly to be accommodated within a test chamber, usually a climatic facility. The circuitry associated with the RF coupling device should contain no active or non-linear components and should present a VSWR of better than 1,5 to a 50 Ω line.

Absolute measurements shall not be made in a test fixture as the antenna of the EUT and the one of the test fixture might be mutually in the near-field range of each other. Hence, only relative measurements shall be performed that shall be related to results taken on a verified free field test site.

The way to relate the results is by a process, referred to as field equalization, in which the relevant parameter, e.g. effective radiated power, receiver sensitivity, etc. is initially measured on a free field test site under normal environmental conditions and then subsequently re-measured using the test fixture under the very same environmental conditions. The difference, e.g. in dB, of the two results is termed the coupling factor of the test fixture and provides the link between all the results of EUT tests carried out in the test fixture and its performance on a verified free field test site. As a general rule, the coupling factor should not be greater than 20 dB.

Emission tests are generally limited to the nominal frequencies, for which the performance of the test fixture has been verified.

Only after it has been verified that the test fixture does not affect performance of the EUT, the EUT can be confidently tested.

The test fixtures shall be suited for the frequency range they are used for.

NOTE: Information on uncertainty contributions, and verification procedures are detailed in clause 5 and clause 6, respectively, of ETSI TR 102 273-6 [i.8].

B.1.4 General requirements for RF cables

All RF cables including their connectors at both ends used within the measurement arrangements and set ups shall be of coaxial type featuring within the frequency range they are used:

- All RF cables exposed to radiation shall be loaded with ferrite beads spaced with a gap of D_{fb} between each other along the entire length of the cable. Such cables are referred to as FCCA. The gap D_{fb} shall be less than half of the signal's wavelength under test.
- All RF cables shall be routed suitably in order to reduce impacts on antenna radiation pattern, antenna gain, antenna impedance.

NOTE: Further details are provided in ETSI TS 103 052 [i.1], clause 6.10.

B.1.5 Conducted measurements

B.1.5.1 One antenna connector arrangement

Figure B.5 shows the measurement arrangements that shall be used in case of a single antenna connector at the EUT.

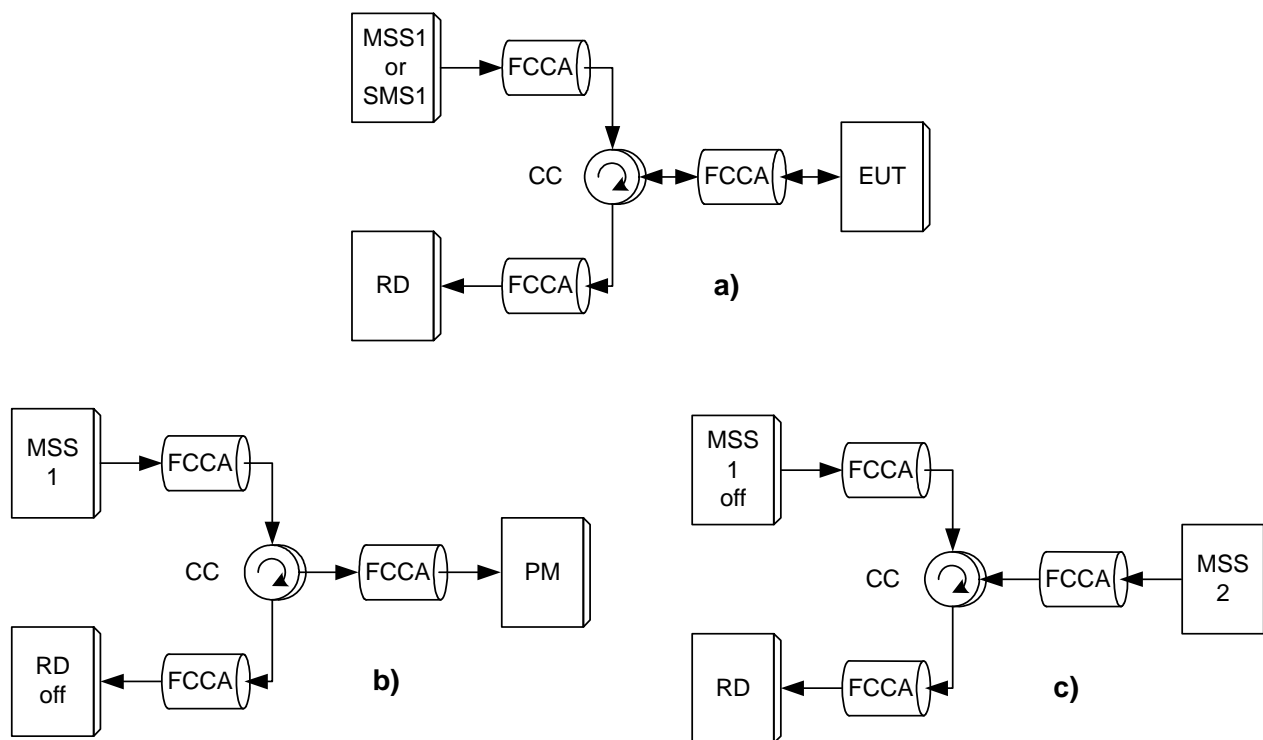

Figure B.5: Measurement arrangement with one antenna connector:
a) for measurement of EUT parameters
b) for adjusting input power to EUT
c) for substitution measurements

B.1.5.2 Two antenna connectors arrangement

Figure B.6 shows the measurement arrangements that shall be used in case of a two antenna connectors at the EUT.

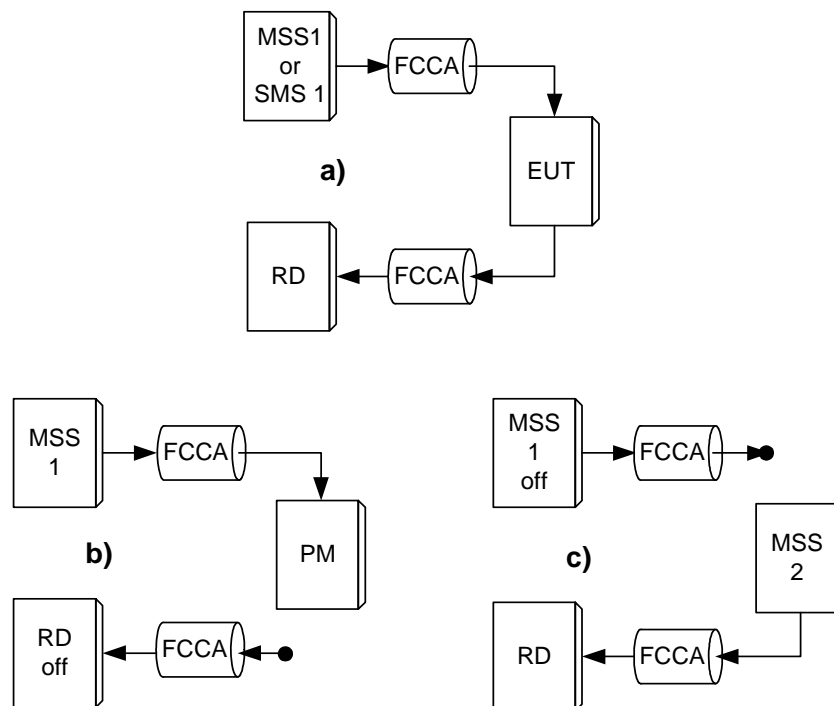

Figure B.6: Measurement arrangement with two antenna connectors:
a) for measurement of EUT parameters
b) for adjusting input power to EUT
c) for substitution measurements

B.1.5.3 Test site requirements

Conducted measurements shall be performed at the antenna connector(s) of the EUT.

B.1.5.4 Site preparation for conducted measurements

B.1.5.4.1 Monochromatic signals

If the measurement arrangement with one antenna connector is used, the measurement set up depicted in figure B.5 applies and the site preparation is as follows:

- 1) The MSS1 shall be connected to the antenna connector of the EUT via the CC providing three terminals.
- 2) The RD shall be connected to the antenna connector of the EUT via the remaining third terminal of the CC.

If the measurement arrangement with two antenna connectors is used, the measurement set up depicted in figure B.6 applies and the site preparation is as follows:

- 1) The MSS1 shall be connected to the receive antenna connector of the EUT.
- 2) The RD shall be connected to the transmit antenna connector of the EUT.

B.1.5.4.2 Modulated signals

If the measurement arrangement with one antenna connector is used, the measurement set up depicted in figure B.5 applies and the site preparation is as follows:

- 1) The SMS1 shall be connected to the antenna connector of the EUT via the CC providing three terminals.

- 2) The RD, i.e. either an RSU receiver or a measurement receiver, shall be connected to the antenna connector of the EUT via the remaining third terminal of the CC.

If the measurement arrangement with two antenna connectors is used, the measurement set up depicted in figure B.6 applies and the site preparation is as follows:

- 1) The SMS1 shall be connected to the receive antenna connector of the EUT.
- 2) The RD, i.e. either an RSU receiver or a measurement receiver, shall be connected to the transmit antenna connector of the EUT.

B.1.6 Radiated measurements

B.1.6.1 One antenna arrangement

Figure B.7 shows the measurement arrangements that shall be used in case one test antenna TA for transmitting and receiving signals are selected for testing the EUT.

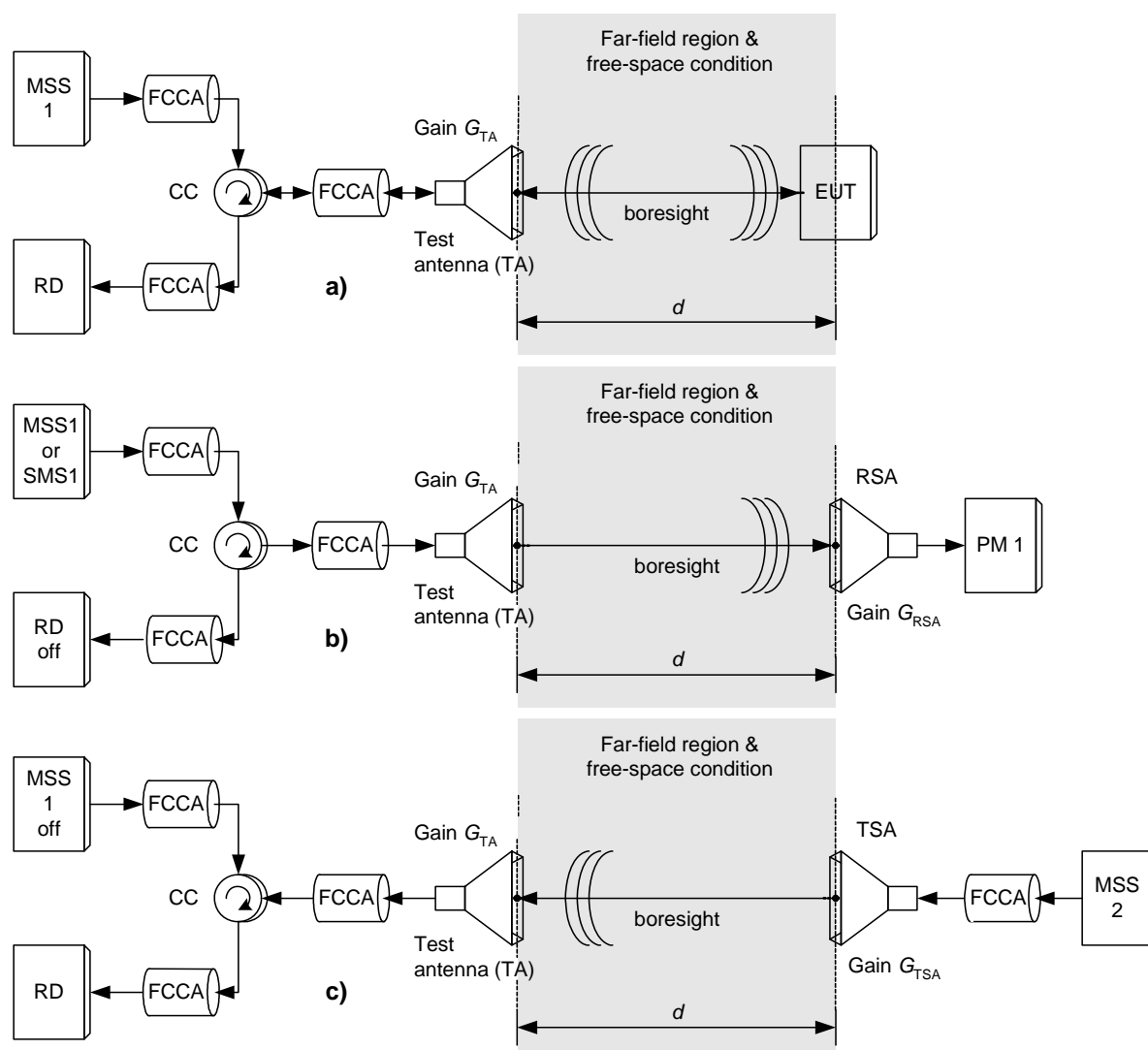

Figure B.7: Measurement arrangement with one test antennas:
a) for measurements of EUT parameters
b) for adjustment of the incident power to the EUT
c) for measurement steps using the substitution antenna

B.1.6.2 Two antennas arrangement

Figure B.8 shows the measurement arrangements that shall be used in case two test antennas, i.e. TTA and RTA, are selected for testing the EUT.

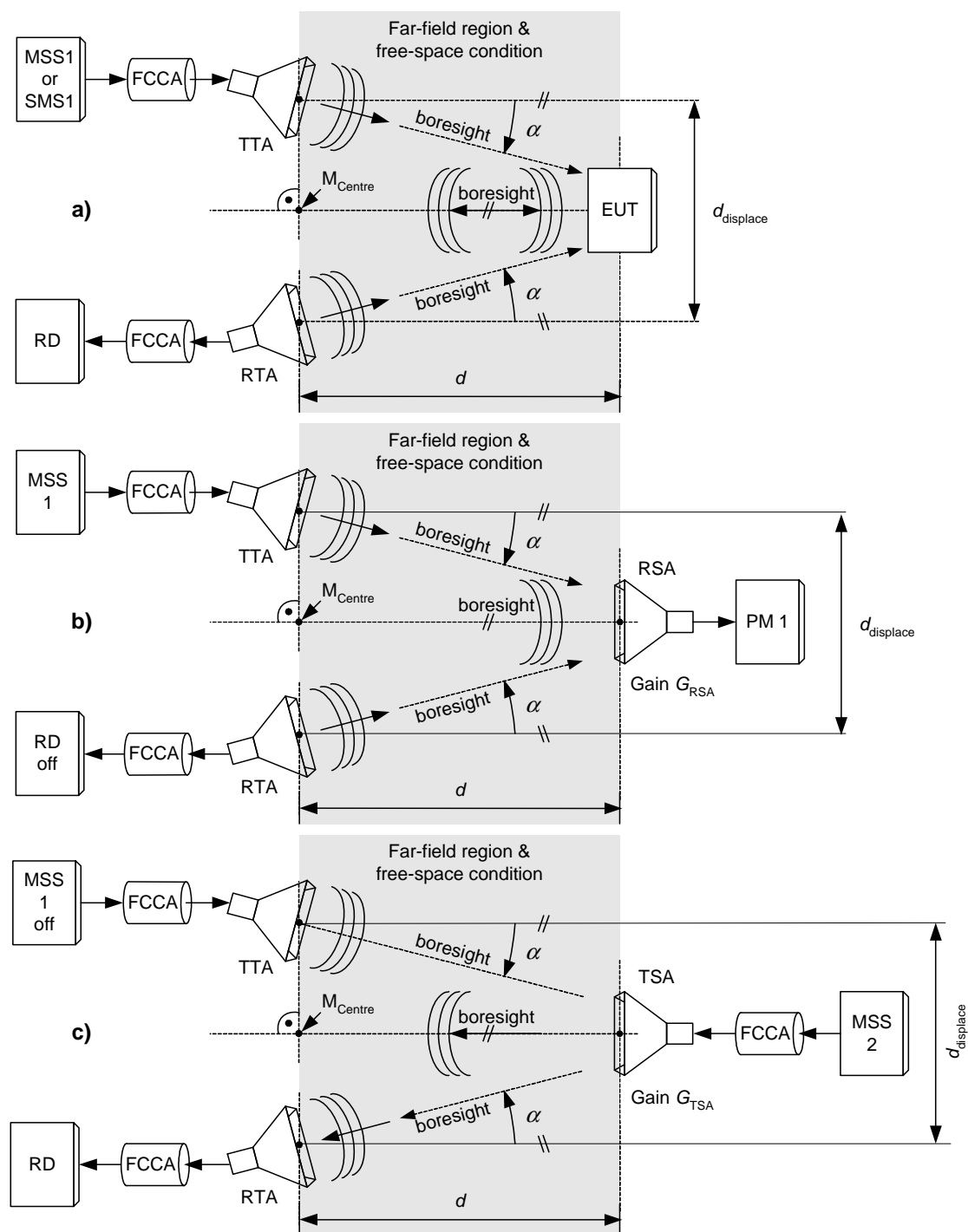

Figure B.8: Measurement arrangement with two test antennas:
a) for measurements of EUT parameters
b) for adjustment of the incident power to the EUT
c) for measurement steps using the substitution antenna

B.1.6.3 Test site requirements

B.1.6.3.1 Measurement distances

Within an open area test site or a shielded anechoic chamber the measurement distance or range length d depicted in figure B.7 and figure B.8 shall be such, that the antennas on both sides of the radio link are mutually in the far field of each other, i.e. d shall be according to the most stringent of the following three equations:

$$d > \frac{2 \times (D_{0,TA} + D_{0,EUT})^2}{\lambda}, \quad d > 5 \times (D_{0,TA} + D_{0,EUT}) \quad \text{and} \quad d > 2 \times \lambda,$$

where $D_{0,TA}$, $D_{0,EUT}$ and λ denote the largest dimension of the test antenna, the EUT antenna, and the wavelength, respectively.

This distance d shall be measured between:

- the centre of aperture of the test antenna TA, in case of a horn antenna, or the feeding point in case the TA is of another type; and
- the feeding point of the EUT antenna if the location of the EUT antenna is known, or the volume centre of the EUT if the location of its antennas is unknown.

B.1.6.3.2 Free-space wave propagation

Within an open area test site or a shielded anechoic chamber a radio path between a transmitting and receiving antenna requires a certain amount of clearance around the central or direct ray if the signal expected from free-space propagation is to be received.

The clearance is usually quoted in terms of Fresnel zones. As depicted in figure B.10 the first Fresnel zone encloses all radio paths from the transmitting to the receiving antenna for which the detour path length $d_{F1} + d_{F2}$ relative to the length d of the direct radio path does not exceed half of the wavelength λ , i.e. a phase change of 180° , of the radiated signal in air.

$$d_{F1} + d_{F2} - d \leq \lambda / 2.$$

Disregarding the non-conductive, dielectric supports of the EUT and the test antenna(s) the clearance around the LOS path between the transmitting and receiving antenna shall be such that at least the first Fresnel zone is free of any obstacles.

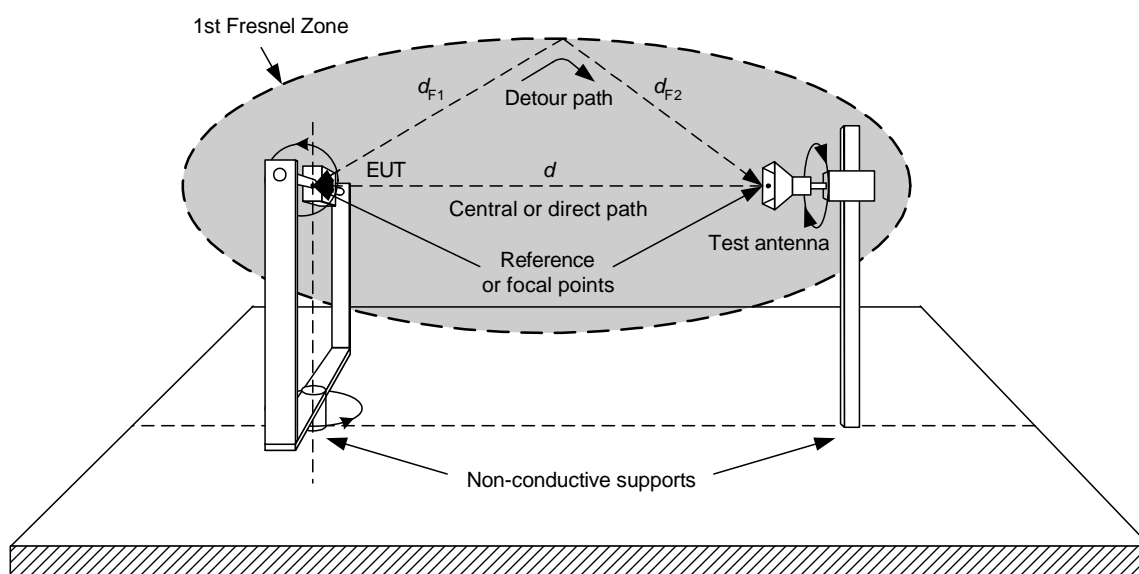

Figure B.9: First Fresnel zone with direct and detour radio path

B.1.6.4 Test and substitution antennas

Test antennas are used to detect the radiation from the EUT or to transmit a signal towards the EUT while substitution antennas together with signal generators are used to replace the EUT and its antenna in substitution measurements.

The test or substitution antenna shall be either LHCP, LP, or XP, whichever is required in the test procedure of the respective EUT parameter. Cross-polarized test or substitution antennas require a XPD > 25 dB within their specified frequency range.

Preferably test or substitution antennas with pronounced directivities shall be used. However, their directivities D_1 relative to an isotropic radiator shall be such that the antennas on both sides of the radio link are mutually in the far field region of each other.

If the symmetry of the test or substitution antenna does not match the one of its feeding cable, a symmetry matching circuit (balun) shall be inserted between the antenna output and the input of its feeding RF cable.

The return loss at the terminal of the test or substitution antenna shall exceed 15 dB within its specified frequency range.

When measuring signals in the frequency range up to 1 GHz the test or substitution antenna shall be either:

- a half wavelength dipole, resonant at the operating frequency; or
- a shortened dipole, adjusted to the properties of a half wavelength dipole; or
- a biconical antenna.

For measurements between 1 GHz and 4 GHz either:

- a half wavelength dipole; or
- a biconical antenna; or
- a horn radiator may be used.

When measuring signals in the frequency range above 4 GHz a horn antenna shall be used.

The type of test or substitution antenna actually used in the tests shall be stated in the test report.

B.1.6.5 Site preparation for radiated OBU measurements

B.1.6.5.1 Monochromatic signals

If the measurement arrangement with one test antenna is used, the measurement set up depicted in figure B.7 applies and the site preparation is as follows:

- 1) The LHCP Test Antenna (TA, TTA: transmit path, RTA: receive path) shall be suited for the range of carrier frequencies f_{Tx} in accordance with clause 4.1.3. It shall be mounted in a shielded anechoic chamber on a vertical pole. The distance between any part of this TA and the ceiling, floor or walls shall be at least 0,5 m. The height of the phase centres above floor of the TA and the CA shall be equal. The CA is either the OBU antenna (EUT) or the RSA. The boresight of the TTA shall point towards the phase centre of the CA.
- 2) The TA shall be connected via a CC featuring three terminals to a MSS1 using FCCAs. The remaining third terminal of the circulator shall be connected via a FCCA to the input of a RD, i.e. spectrum analyser or measuring receiver suitable for the frequencies of the monochromatic signals under consideration. Appropriate precautions shall be taken to prevent overloading the input of the RD.

- 3) The LHCP RSA of gain G_{RSA} shall be suited for the range of carrier frequencies f_{Tx} in accordance with clause 4.1.3. It shall be mounted on a vertical pole within the "quiet zone" at the other end of the shielded anechoic chamber. This pole shall be mounted on a turntable allowing rotating the RSA's phase centre around a vertical axis. The distance between any part of the RSA and the ceiling, floor or walls shall be at least 0,5 m. Further, the distance d between the TTA and the RSA shall be such that the two antennas are mutually in the far field of each other, see clause B.1.6.3.1. The boresight of the RSA shall point towards the phase centre of the TA. The output of the RSA shall be connected directly to the power sensor of power meter PM1 that shall be suitable for measurements at the frequency of the monochromatic signal under consideration.

If the measurement arrangement with two test antennas is used, the measurement set up depicted in figure B.8 applies and the site preparation is as follows:

- 1) The LHCP TTA and the LHCP RTA shall each be suited for the range of carrier frequencies f_{Tx} in accordance with clause 4.1.3. They shall be mounted in a shielded anechoic chamber on a vertical pole. These two antennas shall be displaced either horizontally or vertically such as to minimize the coupling between them. Vertically polarized TTA and RTA shall be displaced vertically whilst horizontally polarized TTA and RTA shall be displaced horizontally. Additionally, the phase centre of the TTA shall be displaced from the phase centre of the RTA by a distance d_{displace} such that the coupling loss between the two antennas becomes greater than 30 dB. The actual coupling loss and the distance d_{displace} between the TTA and RTA shall be stated in the test report together with a unique identification of the TTA and RTA used. The position between both phase centres is denoted M_{centre} . The distance between any part of the TTA and RTA with respect to the ceiling, floor or walls shall be at least 0,5 m. The height of M_{centre} and the phase centre of the CA above floor shall be equal. The CA is either the OBU antenna or the RSA. The boresight of the TTA and RTA shall point towards the phase centre of the CA.
- 2) The TTA shall be connected to a MSS1 using FCCAs.
- 3) The RTA shall be connected to the input of a RD, i.e. spectrum analyser or measuring receiver, using FCCA. The RD shall be suitable for measuring at frequencies of the monochromatic signals under consideration. Appropriate precautions shall be taken to prevent overloading the input of the RD.
- 4) The LHCP RSA of gain G_{RSA} shall be suited for the range of carrier frequencies f_{Tx} in accordance with clause 4.1.3. It shall be mounted on a vertical pole within the "quiet zone" at the other end of the shielded anechoic chamber. This pole shall be mounted on a turntable allowing to rotate the RSA's phase centre around a vertical axis. The RSA shall be positioned close to the middle between the ceiling and the floor. Its boresight shall point to the centre between the phase centres of the TTA and RTA. The distance between any part of the RSA and the ceiling, floor or walls shall be at least 0,5 m. Further, the distance d between the TTA and the RSA as well as between the RTA and the RSA shall be such that the two antennas on both sides of the radio link are mutually in the far field region of each other, see clause B.1.6.3.1. Additionally, the distance d between CA and the position M_{centre} shall be such that the displacement angle α_{displace} between TTA and RTA as observed from the CA complies with:

$$\alpha_{\text{displace}} = 2 \times \arctan\left(\frac{d_{\text{displace}}}{2 \times d}\right),$$

$$\alpha_{\text{displace}} \leq 2^\circ \text{ for horizontally displaced antennas,}$$

$$\alpha_{\text{displace}} \leq 6^\circ \text{ for vertically displaced antennas.}$$

The output of the RSA shall be connected directly to the power sensor of power meter PM1 that shall be suitable for measurements at the frequencies of the monochromatic signals under consideration.

B.1.6.5.2 Modulated signals

If the measurement arrangement with one test antenna is used, the measurement set up depicted in figure B.7 applies and the site preparation is as follows:

- 1) The LHCP test antenna (TA, TTA: transmit path, RTA: receive path) shall be suited for the range of carrier frequencies f_{Tx} in accordance with clause 4.1.3. It shall be mounted in a shielded anechoic chamber on a vertical pole. The distance between any part of this TA and the ceiling, floor or walls shall be at least 0,5 m. The height of the phase centres above floor of the TA and the CA shall be equal. The CA is either the OBU antenna (EUT) or the RSA. The boresight of the TTA shall point towards the phase centre of the CA.
- 2) The TA shall be connected via a CC featuring three terminals to a SMS1 using FCCAs. The remaining third terminal of the circulator shall be connected via a FCCA to the input of a RD, i.e. RSU receiver or measuring receiver, suitable for the frequencies of the modulated signals or messages under consideration. Appropriate precautions shall be taken to prevent overloading the input of the RD.
- 3) The LHCP RSA of gain G_{RSA} shall be suited for the range of carrier frequencies f_{Tx} in accordance with clause 4.1.3. It shall be mounted on a vertical pole within the "quiet zone" at the other end of the shielded anechoic chamber. This pole shall be mounted on a turntable allowing to rotate the RSA's phase centre around a vertical axis. The distance between any part of the RSA and the ceiling, floor or walls shall be at least 0,5 m. Further, the distance d between the TTA and the RSA shall be such that the two antennas are mutually in the far field of each other, see clause B.1.6.3.1. The boresight of the RSA shall point towards the phase centre of the TA. The output of the RSA shall be connected directly to the power sensor of power meter PM1 that shall be suitable for measurements at the frequencies of the monochromatic signals under consideration.

If the measurement arrangement with two test antennas is used, the measurement set up depicted in figure B.8 applies and the site preparation is as follows:

- 1) The LHCP TTA and the LHCP RTA shall each be suited for the range of carrier frequencies f_{Tx} in accordance with clause 4.1.3. They shall be mounted in a shielded anechoic chamber on a vertical pole. These two antennas shall be displaced either horizontally or vertically such as to minimize the coupling between them. Vertically polarized TTA and RTA shall be displaced vertically whilst horizontally polarized TTA and RTA shall be displaced horizontally. Additionally, the phase centre of the TTA shall be displaced from the phase centre of the RTA by a distance $d_{displace}$ such that the coupling loss between the two antennas becomes greater than 30 dB. The actual coupling loss and the distance $d_{displace}$ between the TTA and RTA shall be stated in the test report together with a unique identification of the TTA and RTA used. The position between both phase centres is denoted M_{centre} . The distance between any part of the TTA and RTA with respect to the ceiling, floor or walls shall be at least 0,5 m. The height of M_{centre} and the phase centre of the CA above floor shall be equal. The CA is either the OBU antenna or the RSA. The boresight of the TTA and RTA shall point towards the phase centre of the CA.
- 2) The TTA shall be connected to a SMS1 using FCCAs.
- 3) The RTA shall be connected to the input of a RD, i.e. RSU receiver or measuring receiver, using a FCCA. The RD shall be suited for the frequency of the modulated signal or message under consideration. Appropriate precautions shall be taken to prevent overloading the input of the RD.

- 4) The LHCP RSA of gain G_{RSA} shall be suited for the range of carrier frequencies f_{Tx} in accordance with clause 4.1.3. It shall be mounted on a vertical pole within the "quiet zone" at the other end of the shielded anechoic chamber. This pole shall be mounted on a turntable allowing to rotate the RSA's phase centre around a vertical axis. The RSA shall be positioned close to the middle between the ceiling and the floor. Its boresight shall point to the centre between the phase centres of the TTA and RTA. The distance between any part of the RSA and the ceiling, floor or walls shall be at least 0,5 m. Further, the distance d between the TTA and the RSA as well as between the RTA and the RSA shall be such that the two antennas on both sides of the radio link are mutually in the far field region of each other, see clause B.1.6.3.1. Additionally, the distance d between CA and the position M_{centre} shall be such that the displacement angle α_{displace} between TTA and RTA as observed from the CA complies with:

$$\alpha_{\text{displace}} = 2 \times \arctan \left(\frac{d_{\text{displace}}}{2 \times d} \right),$$

$$\alpha_{\text{displace}} \leq 2^\circ \text{ for horizontally displaced antennas,}$$

$$\alpha_{\text{displace}} \leq 6^\circ \text{ for vertically displaced antennas.}$$

The output of the RSA shall be connected directly to the power sensor of power meter PM1 that shall be suited for the frequencies of the monochromatic signals under consideration.

B.1.6.5.3 Arrangement for OBU transmitter unwanted emissions measurement

Figure B.10 and figure B.11 detail the arrangements used for measurement of the OBU transmitter unwanted emissions.

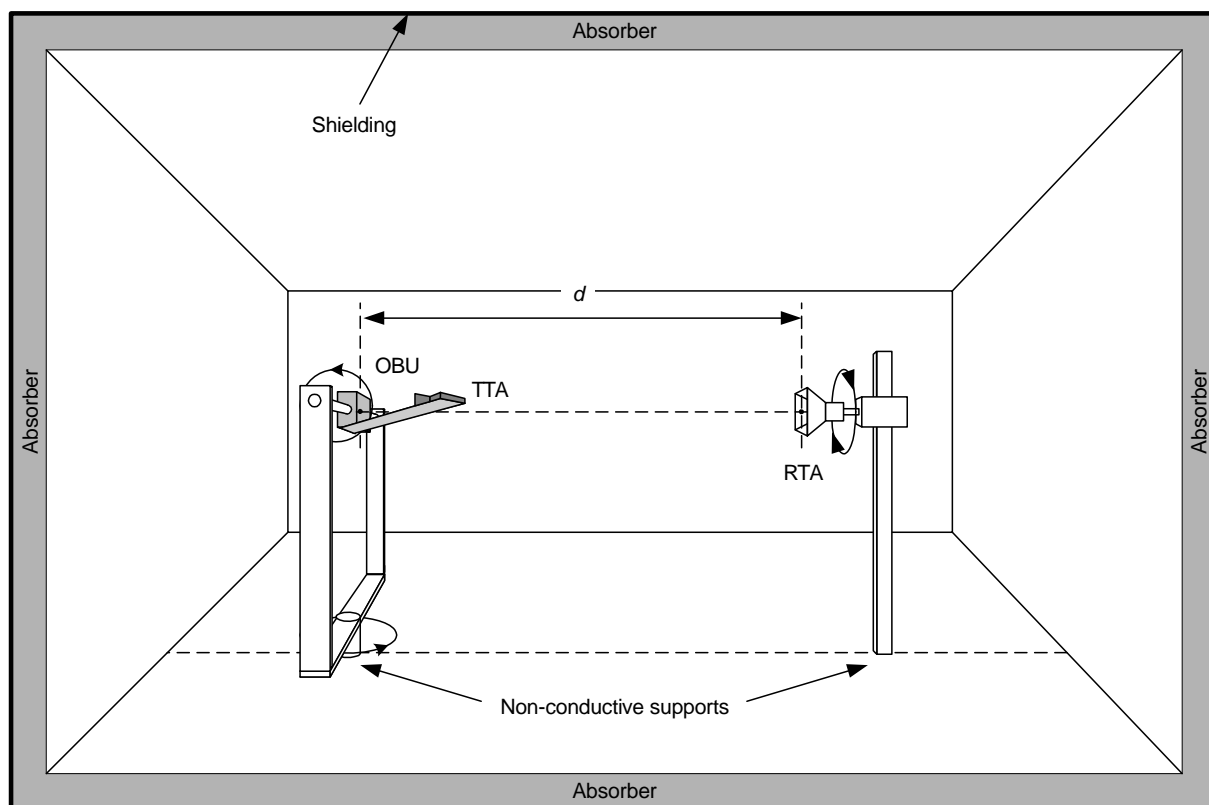

Figure B.10: Test set up for OBU unwanted emission measurements (side view)

Figure B.11 shows the turntable in its initial position MT0. MT1, MT2 and MT3 indicate the other angular positions used.

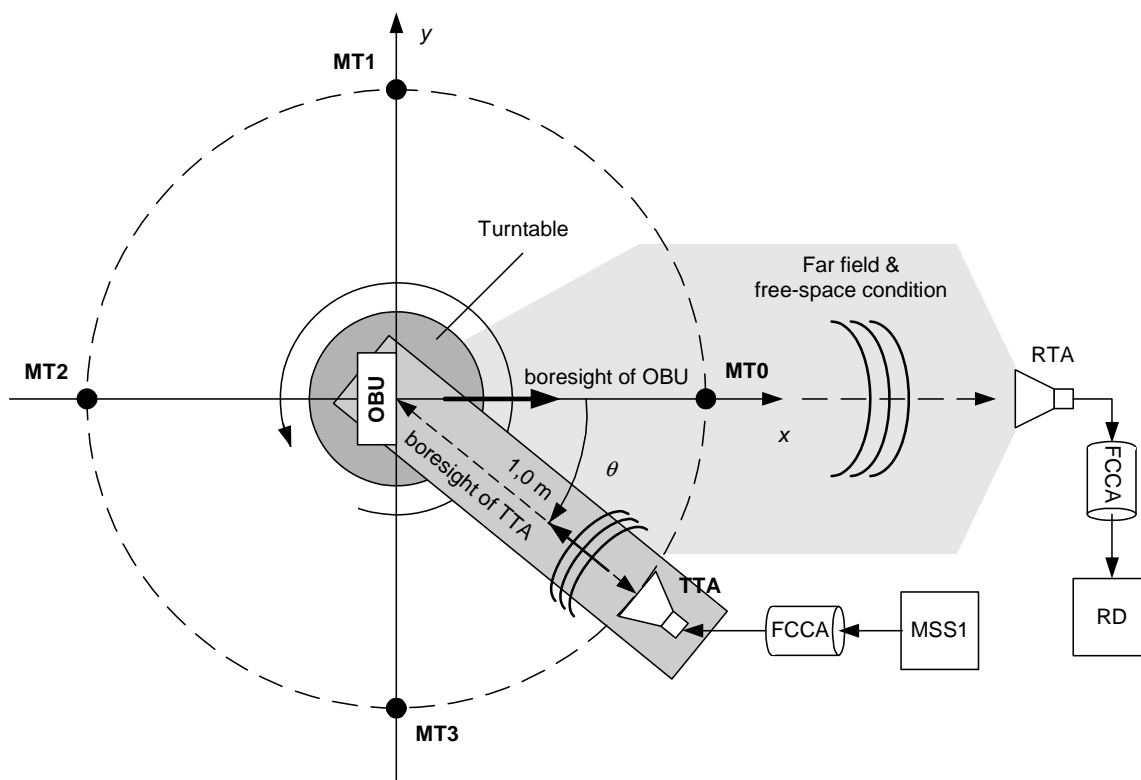

Figure B.11: Test set up for OBU unwanted emission measurements (top view)

For the OBU transmitter unwanted emissions arrangement shown in figure B.10 and figure B.11:

- 1) The LHCP TTA and the OBU antenna shall be installed at fixed distance of 1,0 m with fixed orientation relative to each other on a support, which itself is mounted on a turntable.
- 2) The boresight of the TTA shall point towards the phase centre of the OBU antenna.
- 3) The phase centre M_c of the OBU antenna shall be in the axis of the turntable. If the phase centre M_c of the EUT is unknown and no antenna is visible, the volume centre of the EUT shall be used instead.
- 4) The boresight of the OBU antenna shall point to the phase centre of the RTA in case the turntable is in its initial angular position MT_0 as shown in figure B.11.
- 5) The TTA shall be suited for the range of carrier frequencies f_{Tx} listed in table 3.
- 6) The vertical polarized RTA shall be dedicated to the frequency band actually under test. Different frequency bands shall be tested according to table 6.
- 7) The RTA shall be mounted on a vertical pole. The distance from the RTA to the axis of the turntable shall be such as to allow for full 360° rotation of the turntable. The height of the phase centres above ground of the RTA and the OBU antenna shall be equal.
- 8) The distance between any part of the TTA, and OBU antenna, respectively, and the ceiling, floor or walls shall be at least 0,5 m.
- 9) Every antenna of this set up shall always be mutually in the far field of any other antenna of this set up.
- 10) The distance between any part of the RTA and the ceiling, floor or walls shall be at least half of the wavelength actually under test.
- 11) The RTA shall be connected to the input of a RD, i.e. spectrum analyser or measuring receiver, using a calibrated, ferrited coaxial cable. The RD shall be suitable for measurements at the actual frequency under test.

B.1.6.5.4 Arrangement for OBU receiver selectivity measurement

Figure B.12 and figure B.13 detail the arrangements used for measurement of the receiver selectivity in OBU antenna boresight.

Figure B.12 applies for an RSU with separate antenna connectors for receive and transmit path.

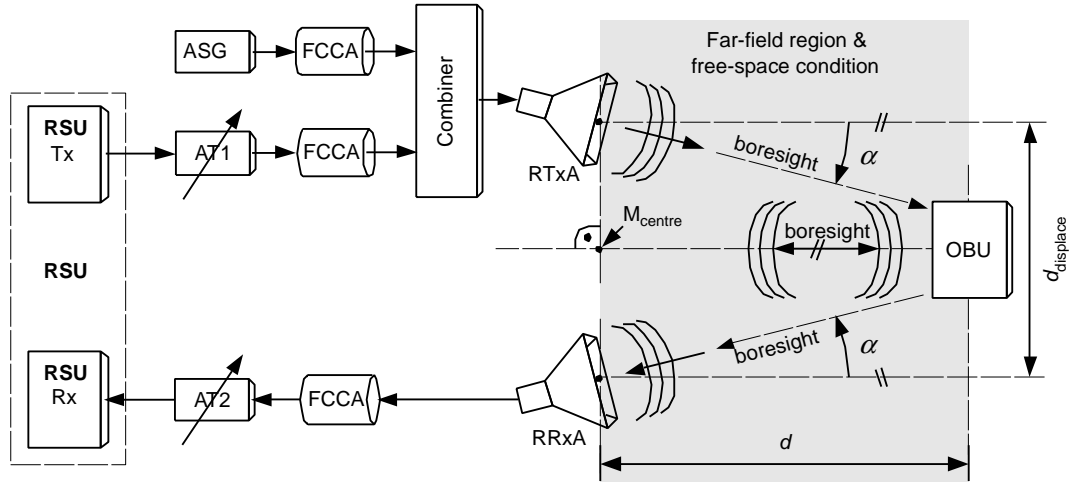

Figure B.12: OBU receive parameter measurement arrangement for horizontally separated RSU antennas and unwanted signal injection in direction of OBU antenna boresight

In case the RSU provides only a single antenna connector for both, the transmit and receive path, a CC shall be used in order to split up the single antenna connector into two antenna connectors, one for the receive path and one for the transmit path; see figure B.13.

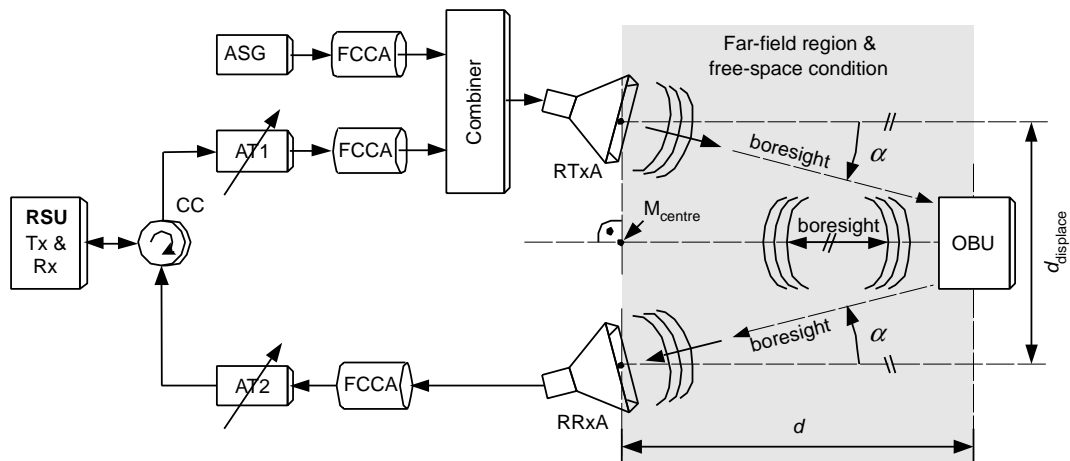

Figure B.13: OBU receive parameter measurement arrangement with CC for horizontally separated RSU antennas and unwanted signal injection in direction of OBU antenna boresight

For all OBU receiver selectivity measurement arrangements:

- 1) The RTxA shall be mounted on a vertical pole within the "quiet zone" of the shielded anechoic chamber. The distance between any part of the RTxA and the ceiling, floor or walls shall be at least 0,5 m.
- 2) The RRxA shall be mounted on a vertical pole within the "quiet zone" of the shielded anechoic chamber. The distance between any part of the RRxA and the ceiling, floor or walls shall be at least 0,5 m.
- 3) The phase centre of the RTxA shall be displaced from the phase centre of the RRxA by d_{displace} . The position between both phase centres is denoted M_{centre} .

- 4) The displacement shall either be horizontally or vertically such as to minimize the coupling between these antennas. The distance d_{displace} shall be such that the coupling loss between the two antennas exceeds 30 dB. The actual coupling loss and the distance d_{displace} shall be stated in the test report together with the unique identification of the RTxA and RRxA used.
- 5) The EUT shall be fixed on a vertical pole at the other end of the shielded anechoic chamber, such that its antenna boresight direction points towards M_{centre} .
- 6) The height of the phase centres above floor of the RTxA, RRxA, TTA and the OBU antenna shall be equal.
- 7) The boresight of the RTxA shall point towards the phase centre of the OBU antenna.
- 8) The boresight of the RRxA shall point towards the phase centre of the OBU antenna.
- 9) The distance d shall be chosen so that the OBU antenna(s) are mutually in the far field of RTxA and RRxA, see clause B.1.6.3.1.
- 10) The displacement angle $\alpha_{\text{displace}} = 2 \times \alpha$ between RTxA and RRxA as observed from the EUT shall comply with:

$$\alpha_{\text{displace}} = 2 \times \arctan\left(\frac{d_{\text{displace}}}{2 \times d}\right),$$

$$\alpha_{\text{displace}} \leq 2^\circ \text{ for horizontally displaced antennas,}$$

$$\alpha_{\text{displace}} \leq 6^\circ \text{ for vertically displaced antennas.}$$

- 11) Ensure by proper decoupling that the signal from the ASG is not disturbing the RSU receiver (this can be validated by a CRC check of the received frames, or a noise level monitoring).

For the arrangement with an RSU with separate antenna connectors for receive and transmit path (figure B.12):

- 1) Connect the RRxA to the RSU receiver via an isolator, an adjustable attenuator AT2 with attenuation ATN_{AT2} , and an FCCA.
- 2) Connect the RSU transmitter to the RTxA via an isolator, an adjustable attenuator AT1, an FCCA and a combiner with three terminals.
- 3) Connect an ASG via an FCCA to the remaining terminal of the combiner.

For the arrangement with an RSU with single antenna connector for receive and transmit path (figure B.13):

- 1) Connect the RSU transceiver via an isolator to a CC.
- 2) Connect the CC to the RTxA via an adjustable attenuator AT1, an FCCA, and a combiner with three terminals.
- 3) Connect an ASG via an FCCA to the remaining terminal of the combiner.
- 4) Connect the RRxA to the CC via an adjustable attenuator AT2 with attenuation ATN_{AT2} and an FCCA.

B.2 Instruments

B.2.1 Receiving device

The RD shall be either a spectrum analyser or a measurement receiver. The subsequent requirements shall apply for a spectrum analyser:

- 1) For any frequency to be measured, the noise floor of the RD shall be at least 10 dB below any power value intended to be measured, e.g. limits for spurious emissions, referred to the location where the limit applies.
- 2) The nominal characteristic impedance of the spectrum analyser's input connector shall match the nominal characteristic impedance of the device connected to this input connector.
- 3) The Video Bandwidth (VBW) shall always be equal to or greater than the Resolution Bandwidth (RBW) selected. The RBW will also be referred to as the reference or equivalent bandwidth.
- 4) For spurious and out-of-band emission measurements the RBW of the spectrum analyser shall be set to the required RBW specified in the test procedure:
 - The measurements may be performed using an RBW that is less than the required one and multiple measurements shall be carried out across the required RBW within non-overlapping frequency bins whose width equal to the selected RBW. The signal power measured within each of these frequency bins shall be added up to obtain the wanted signal power within the required RBW.
 - If the required RBW is less than the smallest one offered by the spectrum analyser and does not match any of the available ones of the spectrum analyser, the measured signal powers shall be performed with a RBW that is closest to the required RBW. The signal power measured shall be scaled according to the ratio of the required RBW to the RBW used while performing the measurements.
- 5) For measurements with a spectrum analyser, the averaging mode shall be used.
- 6) The spectrum analyser shall be used only after the instrument has warmed up. The minimum warm up duration is usually specified in the manual of the spectrum analyser. If this is not the case, a warm up time of at least half an hour shall be used.
- 7) If the dynamic range of the spectrum analyser in conjunction with the required setting of the RBW is not sufficient to measure relevant weak signals in the presence of irrelevant strong signal components appropriate measures to suppress the irrelevant strong signal components shall be applied in agreement between manufacturer and test laboratory and shall be described in the test report.
- 8) The rms detector shall be used.

For the usage of a measurement receiver the above requirements shall apply as well with the exception, where requirements are not applicable, e.g. VBW.

B.2.2 RF power sensor

The subsequent requirements shall apply for RF signal power measurements:

- 1) RF signal power measurements shall not be performed before warm-up of the RF power sensor and the RF power meter. The warm-up duration is usually specified in the manual of the instrument. If this is not the case the instrument shall have a warm-up time of at least half an hour.
- 2) The RF power sensor and RF power meter shall be zeroed before usage according to the requirements and the procedure specified in the manual of the instrument.
- 3) The VSWR at the input of the RF power sensor shall be less than 1,5 within the frequency range of the measurement under investigation.

- 4) The level of the superposition of all signals simultaneously fed to the input of the RF power sensor shall be within the dynamic range of the RF power sensor as stated by its manufacturer for its operational mode.
- 5) The power sensor shall be dedicated for the signal waveform under consideration.

B.2.3 Combiner

All RF combiners used within the measurement arrangements and set ups shall provide coaxial connectors at all ports and feature within the frequency range they are used:

- a nominal characteristic impedance of 50 Ω at each port;
- a VSWR of less than 1,5 at each port;
- an isolation between the input ports of at least 10 dB; and
- an amplitude balance between each of the input ports and the output port of less than 1 dB.

B.3 Power of modulated RSU carrier

Figure B.14 illustrates as an example the basic time-dependent sequence of unmodulated and modulated RSU transmit signals for a case of a modulation index $m = 0,5$, where the transmit signal power P_{mod} , and P_{CW} , respectively, of the modulated, and unmodulated signal parts are equal. The condition of equal power $P_{\text{mod}} = P_{\text{CW}}$ is not required by the present document.

NOTE: Figure B.14 does not allow extracting valid timing relations between carrier frequency and bit rate.

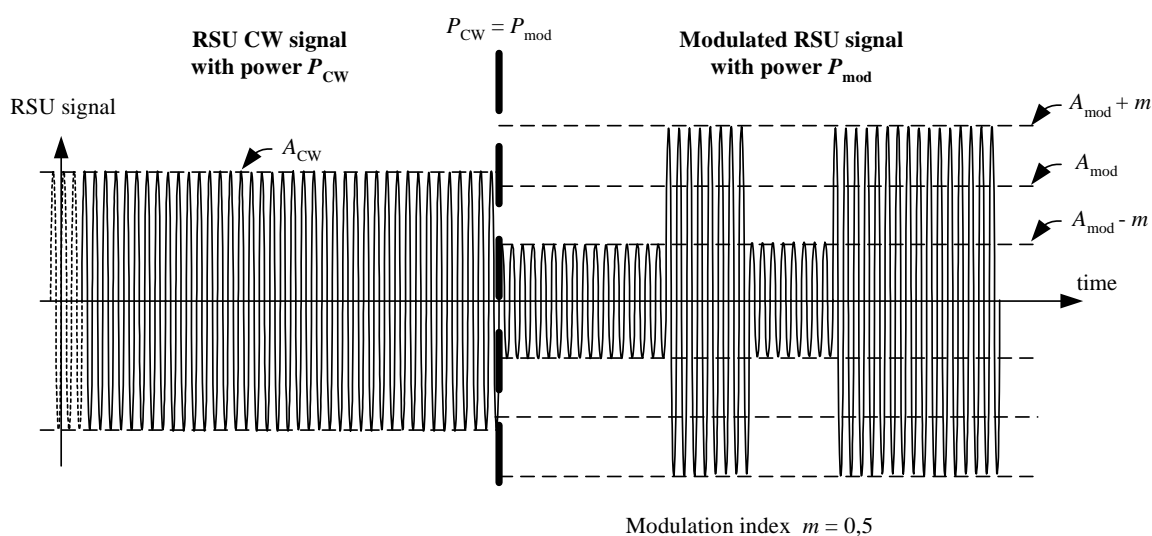

Figure B.14: RSU transmit signal

An RSU normally allows for a transmit mode "send unmodulated carrier", i.e. continuous transmission of the unmodulated carrier. Thus, it is possible to measure the power of the unmodulated signal in figure B.14, $P_{\text{CW}} = \frac{1}{2} A_{\text{CW}}^2$, by means of a thermal power sensor or a spectrum analyser.

An RSU does normally not allow for continuous transmission of the modulated carrier. In what follows a procedure is described, that allows to estimate the power $P_{\text{mod}} = \frac{1}{2} A_{\text{mod}}^2 (1 + m^2)$ of the modulated carrier:

- 1) Set the RSU in a mode that it transmits an unmodulated carrier. Measure P_{CW} .

- 2) Set the RSU in a mode that it transmits BSTs of maximum possible duration T_{mod} with a repetition period as close as possible to twice of the duration of a BST transmission. The gap between subsequent BST transmissions has duration T_{CW} . The duration T_{mod} and T_{CW} shall be constant within the following test.
- 3) Measure the average signal power P_{avg} of the signal transmitted according to step 2 with measurement time of at least ten times the repetition period $T_{\text{CW}} + T_{\text{mod}}$.
- 4) Measure the duration T_{mod} and T_{CW} .
- 5) Calculate $P_{\text{mod}} = P_{\text{avg}} + \frac{T_{\text{CW}}}{T_{\text{mod}}} (P_{\text{avg}} - P_{\text{CW}})$.

B.4 Bit error ratio measurements

B.4.1 Basics

The required BER for communication is referred to as parameters D9 and U9 in CEN EN 12253 [1].

BER measurements shall be conducted either in a direct or indirect way.

The direct way requires the possibility to generate and receive a continuous bit stream of significant length. The fraction of erroneous bits out of the total number of received bits is the BER. This approach uses standard laboratory equipment for BER measurement and requires a modification of the EUT.

The indirect way is based on generating and receiving frames of limited length where any bit errors in the frame can be detected by means of a CRC. The fraction of erroneous frames out of the total number of frames, which is called the FER, allows to estimate the BER assuming that bit errors are equally distributed. Precautions shall be taken to prevent drops of error-free received frames caused by specific implementation of upper layers.

B.4.2 BER measurement

BER may be measured indirectly, see clause B.4.3.

B.4.3 FER measurement

B.4.3.1 Mathematical expressions

Assuming equally distributed and statistically independent occurrence of erroneous bits the following relations between FER , BER , and total number N of transmitted bit within a single frame apply:

$$FER = 1 - (1 - BER)^N,$$

$$BER = 1 - 10^{\frac{\lg(1-FER)}{N}} = 1 - \sqrt[N]{1-FER}.$$

The minimum number C_F of frames together with the frame size shall be reported.

EXAMPLE 1: With $BER = 10^{-6}$ and frame length $N = 1\,000$ the equivalent FER amounts to approximately $1,0 \times 10^{-3}$. A reasonable number C_F of frames to be transmitted is 10 000, i.e. 10 frames may be lost on average.

EXAMPLE 2: For a large value of FER , e.g. 0,999 9 which may result from a $BER = 2,0 \times 10^{-2}$ as used for test, a reasonable number C_F of frames to be transmitted is 100 000, i.e. 10 frames may be error-free on average. The very large number of frames to be transmitted is to be able at all to estimate the BER, as a small variation in erroneous frames may change significantly the corresponding estimated BER.

B.4.3.2 Equipment

FER measurements can be easily conducted using the set of test messages TM1. Thus standard DSRC equipment might be used, if the following software configuration has been implemented:

- DSRC communication sequence starting with an initialization phase conform to ISO 14906 [2], clause 6.2 followed by successive ECHO commands conform to ISO 14906 [2], clause 7.2.17.

In case of a bit error performance measurement of the RSU receiver, the following additional configuration requirements apply:

- An ECHO.request transmitted by the RSU and not responded by the EUT shall be treated as "never transmitted", as in this case the ECHO.request was received erroneous.
- An erroneous ECHO.response received shall not result in a retransmission of the related ECHO.request as normally required by the DSRC protocol, but shall just lead to an increment of the frame error counter.

In case of a bit error performance measurement of the OBU receiver, the following additional configuration requirements apply:

- An ECHO.request transmitted by the RSU and not responded by the EUT shall not result in a retransmission of the related ECHO.request as normally required by the DSRC protocol, but shall just lead to an increment of the frame error counter.
- An erroneous ECHO.response received shall not result in a retransmission of the related ECHO.request as normally required by the DSRC protocol, but shall just be ignored, as in this case the ECHO.request was received error free at the EUT.

B.4.3.3 Procedure

- 1) The RSU shall perform initialization with the EUT by exchanging BST and VST. The signal level at the OBU receiver input relevant for BER measurement shall be set to the level required for the test. The signal level at the RSU receiver input shall be set at a minimum value such that the BER of the received messages is 10^{-6} . In the unexpected case of transmission errors, the initialization attempt shall be repeated. During initialization any additional interfering signals as requested by a specific test procedure shall be switched off.
- 2) The RSU shall transmit a single ECHO command of maximum length. Reception of the corresponding response from the EUT is expected to be error free. In case of errors, repetitions of the ECHO command according to the DSRC protocol shall happen. This finalizes initialization.

In case of a bit error performance measurement of the RSU receiver, the following additional procedural steps shall be processed:

- 3) Repeat step 2 C_F times, C_F see clause B.4.3.1, and report the total number C_E of erroneous ECHO.response frames received by the RSU. Calculate the actual Frame Error Ratio $FER = C_E / C_F$. Continue with step 5.

In case of a bit error performance measurement of the OBU receiver, the following additional procedural steps shall be processed:

- 4) Repeat step 2 for C_F times, C_F see clause B.4.3.1, and report the total number C_E of ECHO.response frames not received by the RSU. Calculate the actual Frame Error Ratio $FER = C_E / C_F$.
- 5) Calculate *BER* out of *FER* according to clause B.4.3.1.

Annex C (normative): Environmental profile

C.1 General Requirements

The requirements of the present document shall apply for the environmental profile as specified in clause C.2. Additional environmental profiles as defined in clause C.3 may be selected by the manufacturer.

C.2 Mandatory environmental conditions

The normal temperature and humidity conditions for tests shall be any convenient combination of temperature and relative humidity within the following ranges:

- temperature: +15 °C to +35 °C;
- relative humidity: 20 % to 75 %.

C.3 Additional environmental conditions

The manufacturer may add environmental conditions classified in categories according to table C.1.

Table C.1: Extreme environmental conditions

Temperature category	RSU	OBU
Category I (General):	temperature: -20 °C to +55 °C	temperature: -20 °C to +55 °C
Category II:	IEC 60721-3-4 [i.9] / 4K2	IEC 60721-3-5 [i.10] / 5K2
Category III	IEC 60721-3-4 [i.9] / 4K3	IEC 60721-3-5 [i.10] / 5K3
Category IV:	IEC 60721-3-4 [i.9] / 4K4	IEC 60721-3-5 [i.10] / 5K4

The extreme environmental conditions for tests should be any convenient selection of environmental parameter values, except temperature, of a single category. For tests at extreme temperature, measurements should be made at both, the upper and lower temperature of the selected category.

Annex D (informative): Maximum Measurement Uncertainty

Table D.1 shows the recommended values for the maximum measurement uncertainty figures.

Table D.1: Maximum measurement uncertainty

Parameter	Uncertainty
RF power (conducted)	±1,5 dB
RF frequency, relative	±1 x 10 ⁻⁷
Radiated emission of transmitter, valid to 40 GHz	±6 dB
Adjacent channel power	±5 dB
Sensitivity	±3 dB
Two and three signal measurements	±4 dB
Two and three signal measurements using radiated fields	±6 dB
Radiated emission of receiver, valid to 40 GHz	±6 dB
Temperature	±1 K
Relative humidity	±5 %

Annex E (informative): Bibliography

- Directive 98/34/EC of the European Parliament and of the Council of 22 June 1998 laying down a procedure for the provision of information in the field of technical standards and regulations.
- ETSI EN 301 489: "Electromagnetic compatibility and Radio spectrum Matters (ERM); Electro Magnetic Compatibility (EMC) standard for radio equipment and services".
- ETSI EG 203 336: "Electromagnetic compatibility and Radio spectrum Matters (ERM); Guide for the selection of technical parameters for the production of Harmonised Standards covering article 3.1(b) and article 3.2 of Directive 2014/53/EU".
- ETSI EN 300 674-1: "Electromagnetic compatibility and Radio spectrum Matters (ERM); Road Transport and Traffic Telematics (RTTT); Dedicated Short Range Communication (DSRC) transmission equipment (500 kbit/s / 250 kbit/s) operating in the 5,8 GHz Industrial, Scientific and Medical (ISM) band; Part 1: General characteristics and test methods for Road Side Units (RSU) and On-Board Units (OBU)".
- ETSI EN 300 674-2-1: "Transport and Traffic Telematics (TTT); Dedicated Short Range Communication (DSRC) transmission equipment (500 kbit/s / 250 kbit/s) operating in the 5 795 MHz to 5 815 MHz frequency band; Part 2: Harmonised Standard covering the essential requirements of article 3.2 of Directive 2014/53/EU; Sub-part 1: Road Side Units (RSU)".

Annex F (informative): Change History

Version	Information about changes
2.1.1	First published version covering Directive 2014/53/EU. Receiver selectivity characteristics have become an essential requirement.
2.2.1	Former clause 4.1 on mechanical and electrical design was deleted. The environmental profile specification was clarified. The wording for the power supply requirement was simplified. Clarifications in the receiver selectivity specification were added. A specification of the co-channel rejection and respective test cases were added. The measurement uncertainty values have become informative recommendations. Calibration procedures are now implicitly assumed. Some test setups were specified by reference and the corresponding detailed descriptions were deleted.

History

Document history		
V1.1.1	February 1999	Publication as ETSI EN 300 674
V1.1.1	February 1999	Publication as ETSI ES 200 674-2
V1.1.1	August 2004	Publication
V2.1.1	November 2016	Publication
V2.2.0	March 2019	EN Approval Procedure AP 20190616: 2019-03-18 to 2019-06-17
V2.2.1	June 2019	Publication