

**Access and Terminals (AT);
Analogue access to the
Public Switched Telephone Network (PSTN);
Subscriber line protocol over the local loop for
display (and related) services;
Part 1: On-hook data transmission**



Reference

REN/AT-030006-1

Keywords

data, PSTN, protocol, service

ETSI

650 Route des Lucioles
F-06921 Sophia Antipolis Cedex - FRANCE

Tel.: +33 4 92 94 42 00 Fax: +33 4 93 65 47 16

Siret N° 348 623 562 00017 - NAF 742 C
Association à but non lucratif enregistrée à la
Sous-Préfecture de Grasse (06) N° 7803/88

Important noticeIndividual copies of the present document can be downloaded from:
<http://www.etsi.org>

The present document may be made available in more than one electronic version or in print. In any case of existing or perceived difference in contents between such versions, the reference version is the Portable Document Format (PDF). In case of dispute, the reference shall be the printing on ETSI printers of the PDF version kept on a specific network drive within ETSI Secretariat.

Users of the present document should be aware that the document may be subject to revision or change of status. Information on the current status of this and other ETSI documents is available at <http://www.etsi.org/tb/status/>

If you find errors in the present document, send your comment to:
editor@etsi.fr

Copyright Notification

No part may be reproduced except as authorized by written permission.
The copyright and the foregoing restriction extend to reproduction in all media.

© European Telecommunications Standards Institute 2000.
All rights reserved.

Contents

Intellectual Property Rights	4
Foreword.....	4
1 Scope	6
2 References	6
3 Definitions and abbreviations.....	7
3.1 Definitions	7
3.2 Abbreviations	7
4 Data encoding.....	7
5 Protocol requirements.....	8
5.1 Presentation layer	8
5.2 Data Link layer	8
5.3 Physical layer	9
6 Data transmission requirements: signalling, timing and tolerance.....	10
6.1 Data transmission associated with ringing	10
6.1.1 Data transmission during ringing.....	10
6.1.2 Data transmission prior to ringing	11
6.2 Data transmission not associated with ringing	12
6.3 TAS physical characteristics	14
6.3.1 DT-AS	14
6.3.2 RP-AS.....	14
Annex A (normative): TE connected to the LE via a pair gain system - considerations for the Z' interface	15
Annex B (normative): DTMF based subscriber line protocol.....	16
B.1 Introduction	16
B.2 Line seizure phase	16
B.3 Alerting phase	16
B.4 Information transfer phase.....	16
B.5 Tests	17
Annex C (informative): Reference configurations.....	18
Annex D (informative): Data transmission format.....	19
Bibliography	20
History	21

Intellectual Property Rights

IPRs essential or potentially essential to the present document may have been declared to ETSI. The information pertaining to these essential IPRs, if any, is publicly available for **ETSI members and non-members**, and can be found in SR 000 314: "*Intellectual Property Rights (IPRs); Essential, or potentially Essential, IPRs notified to ETSI in respect of ETSI standards*", which is available from the ETSI Secretariat. Latest updates are available on the ETSI Web server (<http://www.etsi.org/ipr>).

The attention of ETSI has been drawn to the Intellectual Property Rights (IPRs) listed below which are, or may be, or may become, Essential to the present document and, in particular, on-hook data transmission associated with ringing, network operator option: "transmission during ringing". The IPR owner has undertaken to grant irrevocable licences, on fair, reasonable and non-discriminatory terms and conditions under these IPRs pursuant to the ETSI interim IPR Policy. Further details pertaining to these IPRs can be obtained directly from the IPR owner.

The present IPR information has been submitted to ETSI and pursuant to the ETSI IPR Policy, no investigation, including IPR searches, has been carried out by ETSI. No guarantee can be given as to the existence of other IPRs not referenced in SR 000 314 (or the updates on the ETSI Web server) which are, or may be, or may become, essential to the present document.

IPRs:

USA	4,582,956
Canada	1,225,726
Belgium	0,150,181
France	0,150,181
United Kingdom	0,150,181
Japan	1,832,616
Netherlands	0,150,181
Sweden	0,150,181
Germany	3,376,377

The related International Patent Application (WHO 85/00488) designated the following countries: AT, AU, BE, BR, CH, DE, DK, FI, FR, GB, JP, LU, NL, NO, SE and SU.

IPR owner: AT&T:
10 Independence Blvd.
Warren, NJ 07059-6799
USA

Contact: Mr. Rich De Felice
Tel: +1 (305) 569-3926
Fax: +1 (305) 569-4773

Foreword

This European Standard (Telecommunications series) has been produced by ETSI Technical Committee Access and Terminals (AT), and is now submitted for the ETSI standards One-step Approval Procedure.

Version 1.2.1 of the present document had been submitted to One-step Approval Procedure 200017 but was withdrawn due to the receipt of substantial technical comments.

The present document is part 1 of a multi-part standard covering the PSTN subscriber line protocol over the local loop for display (and related) services, as described below:

- Part 1: "On-hook data transmission";
- Part 2: "Off-hook data transmission";
- Part 3: "Data link message and parameter codings".

Proposed national transposition dates	
Date of latest announcement of this EN (doa):	3 months after ETSI publication
Date of latest publication of new National Standard or endorsement of this EN (dop/e):	6 months after doa
Date of withdrawal of any conflicting National Standard (dow):	6 months after doa

1 Scope

The present document specifies the subscriber line protocol for the support of PSTN display services at Local Exchange (LE) in "on-hook" state. The subscriber line protocol is accomplished by using asynchronous voice-band Frequency-Shift Keying (FSK) signalling. The data transmission specified in the present document is provided only in the direction from the LE to the TE.

In addition, annex B is provided in order to allow the continuation of use in those networks that already implemented a Dual Tone Multi-Frequency (DTMF) based subscriber line protocol.

The requirements imposed on the FSK signalling-based subscriber line protocol deal with data encoding, data transmission requirements and the three layers of the protocol at the network side of the interface:

- presentation layer;
- data link layer; and
- physical layer.

The requirements imposed on the DTMF-based subscriber line protocol deal with the transfer of the DTMF coded display information. The procedures and the encoding arrangements are specified in annex B of the present document.

Terminal Equipment (TE) can be connected by analogue access directly to the LE or through an Access Network (AN). In the latter case, data transmission can be applied from the LE or from elsewhere in the network hence a transmission path needs to exist from the LE to the TE before data transmission. It is the network operator's responsibility to ensure transmission path establishment. Transmission path establishment procedures are outside the scope of the present document.

2 References

The following documents contain provisions which, through reference in this text, constitute provisions of the present document.

- References are either specific (identified by date of publication, edition number, version number, etc.) or non-specific.
- For a specific reference, subsequent revisions do not apply.
- For a non-specific reference, the latest version applies.
- A non-specific reference to an ETS shall also be taken to refer to later versions published as an EN with the same number.

- [1] ETSI TR 101 182: "Analogue Terminals and Access (ATA); Definitions, abbreviations and symbols".
- [2] ETSI ETS 300 648 (1997): "Public Switched Telephone Network (PSTN); Calling Line Identification Presentation (CLIP) supplementary service; Service description".
- [3] ETSI ES 201 235: "Specification of Dual Tones Multi-Frequency (DTMF) Transmitters and Receivers", Part 1 to Part 4.
- [4] CCITT Recommendation Q.11 (1988): "Numbering plan for the international telephone service".
- [5] CCITT Recommendation T.50 (1992): "International Reference Alphabet (IRA) (Formerly International Alphabet No.5 or IA5) - Information technology - 7-bit coded character set for information interchange".
- [6] CCITT Recommendation V.23 (1988): "600/1200-baud modem standardized for use in the general switched telephone network".

- [7] ETSI EN 300 659-3 (V1.3.1): "Public Switched Telephone Network (PSTN); Subscriber line protocol over the local loop for display (and related) services; Part 3: Data link message and parameter codings".

3 Definitions and abbreviations

3.1 Definitions

For the purposes of the present document, the following terms and definitions apply:

calling line identity: see ETS 300 648 [2]

graphic character: character that has a visual representation normally hand-written, printed or displayed; in IRA characters 2/1 to 7/14 (see CCITT Recommendation T.50 [5])

long silent period: silent period between ring patterns

loop state: see TR 101 182 [1]

mark bit: symbol "1" (see CCITT Recommendation V.23 [6])

quiescent state: see TR 101 182 [1]

ring pattern: consists of one or more ringing pulses separated by short silent periods

Ringing Pulse Alerting Signal (RP-AS): pulse of ringing current used to alert the TE that a data transmission will follow. Duration of RP-AS is specified in the present document

ringing pulse: pulse of ringing current used for call arrival indication within a ring pattern. Ringing attributes (current values, duration of ringing pulses, number of ringing pulses in the ring patterns, cadence, etc.) are network specific

short silent period: silent period between ringing pulses in a ring pattern

space bit: symbol "0" (see CCITT Recommendation V.23 [6])

3.2 Abbreviations

For the purposes of the present document, the following abbreviations apply:

AN	Access Network
AS	Alerting Signal
CLIP	Calling Line Identification Presentation
DC	Direct Current
DT-AS	Dual Tone-Alerting Signal
DTMF	Dual Tone Multi-Frequency
FSK	Frequency-Shift Keying
IRA	International Reference Alphabet
LE	Local Exchange
LR	Line Reversal
LR+DT-AS	Line Reversal followed by a Dual Tone-Alerting Signal
PSTN	Public Switched Telephone Network
RP-AS	Ringing Pulse Alerting Signal
TAS	TE Alerting Signal
TE	Terminal Equipment

4 Data encoding

Data encoding shall be as described in EN 300 659-3 [7].

5 Protocol requirements

Annex D gives an overview of the data transmission format.

5.1 Presentation layer

The Presentation layer specifies the formats and sequence of information that LE transmits to the TE (Presentation layer message).

The Presentation layer message format is illustrated in figure 1.

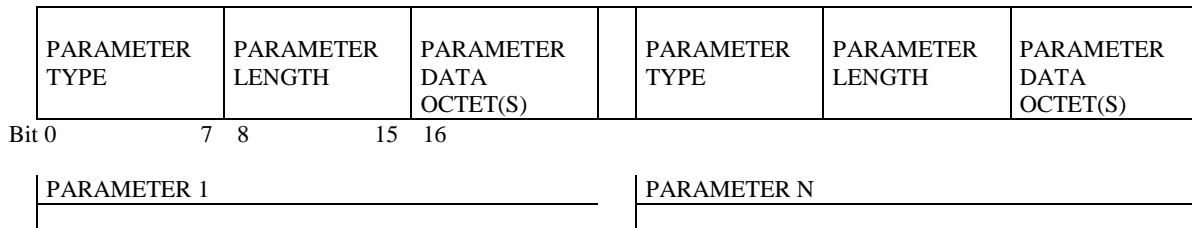

Figure 1: Presentation layer message format

Each parameter shall consist of a Parameter type, a Parameter length and Parameter octet(s).

Parameter type (1 octet): shall contain an assigned binary encoded value to identify the Parameter.

Parameter length (1 octet): shall contain the binary encoded number of Parameter octets that follow.

Parameter data octet(s): shall contain 1 or more (up to 253) octets. The value shall be either binary encoded or encoded in accordance with CCITT Recommendation T.50 [5].

5.2 Data Link layer

The Data Link layer is responsible for providing bit error detection capability and for prepending the Channel Seizure Signal and the Mark Signal to the Presentation layer message.

The Data Link layer message format shall be as illustrated in figure 2.

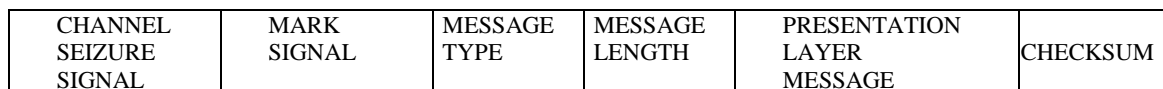

Figure 2: Data Link message format

Channel Seizure Signal: shall consist of a block of 300 continuous bits of alternating "0"s and "1"s. The first bit to be transmitted shall be a "0". The last bit to be transmitted shall be a "1". It shall start the data transmission only in "on-hook" data transmission.

Mark Signal: shall either consist of a block of 180 ± 25 mark bits or 80 ± 25 mark bits.

Message type (1 octet): shall contain an assigned binary encoded value to identify the message.

Message length (1 octet): shall contain the binary encoded number of octets of the Data Link layer message (not including the Message type, Message length and Checksum octets). This allows a presentation-layer message length between 3 and 255 octets.

Presentation Layer Message: shall contain at least one parameter.

Checksum octet (1 octet): shall contain the two's complement of the modulo 256 sum of all the octets in the message starting from the Message type octet up to the end of the message (excluding the Checksum itself).

The protocol does not support error correction or message retransmission. No sequence number or acknowledgement shall be used for the data messages transmitted from the LE to the TE.

NOTE: a Data Link message, received by the TE, resulting in an incorrect checksum should be discarded by the TE.

5.3 Physical layer

Physical layer requirements refer to the network end of the local loop (interface point Z, see annex C).

Simplex asynchronous voiceband data transmission technique is used to transfer data to the TE. A frequency modulator is required in the LE and a demodulator in the TE. The frequency modulator shall meet 1 200 baud V.23 [6] standard characteristics as specified in CCITT Recommendation V.23 [6] for the forward data transmission channel.

The transmission levels are described in table 1.

Table 1: Transmission levels

Signal Level	-14,5 dBV \pm 2,5 dB at the interface point Z, When the interface is terminated with the reference impedance Z_R defined in TR 101 182 [1].
Signal Purity	Total voltage of all extraneous signal in the band 300 Hz-3 400 Hz at the interface point Z shall be at least 30 dB lower than the level of the signal fundamental frequency.
Source impedance	Network specific.
NOTE: The level requirement is intended to take account of signal levels of existing interfaces.	

When sending a Data Link message the following requirements shall be met:

- each data octet (i.e. Message type, Message length, each Presentation layer message octet and Checksum) shall be enveloped by a Start bit (space) and a Stop bit (mark) in the format shown in figure 3; in order to avoid corruption of the checksum by premature cessation of transmission, the Stop bit following the checksum shall be followed by an additional one to ten Mark bits;

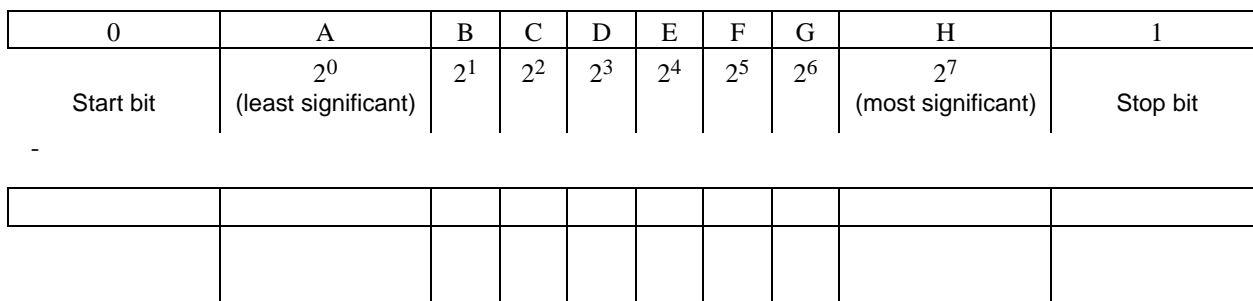

Figure 3

- the order of bits transmitted to line is: Start bit first, Stop bit last;
- the octets are transmitted according to the growing order of their number: octet 1 first, octet 2 second, etc.;
- the data signal shall be continuous.

FSK modulation shall be applied only during transmission of data hence it shall be immediately stopped after the last bit of Data Link message has been transmitted.

6 Data transmission requirements: signalling, timing and tolerance

Data transmission requirements refer to the network end of the local loop (interface point Z, see annex C).

Interface Z shall support data transmission to TE in either or both of the following modes:

- transmission is associated with ringing;
- transmission is not associated with ringing.

The data transmission mode is service-dependant.

6.1 Data transmission associated with ringing

Two methods associated with ringing are defined to transmit information to the TE:

- data transmission during ringing;
- data transmission prior to ringing.

It is a network operator option as to which method is used.

6.1.1 Data transmission during ringing

Data transmission shall occur during the first long silent period between two ring patterns (see figure 4). The first long silent period shall be of sufficient duration for the data to be transmitted.

The initial application of ringing will provide an alert signal to the TE that data transmission is to be expected.

If the TE goes in loop state before or during the data transmission, normal incoming call procedure shall occur and the data transmission shall be aborted.

Timing

FSK modulation transmission shall begin not less than 500 ms, but less than 2 000 ms after the end of the first ring pattern. The second ring pattern shall start not less than 200 ms after FSK modulation transmission is stopped (see figure 4 and table 2). The lower limits are required to enable TE to apply and remove appropriate circuit for data reception.

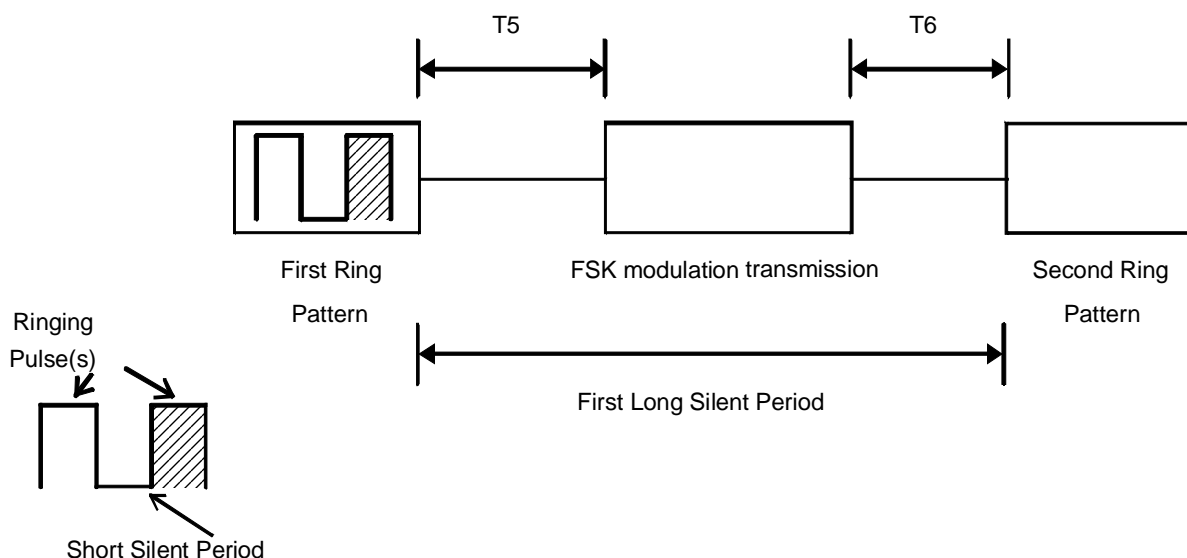

Figure 4: Data transmission during ringing

Table 2: Data transmission during ringing - timer values

$500 \text{ ms} \leq T5 < 2\,000 \text{ ms}$
$T6 \geq 200 \text{ ms}$

6.1.2 Data transmission prior to ringing

A TE Alerting Signal (TAS) will be used to signal to the TE that data transmission is to be expected.

Data transmission shall occur prior to normal first ring pattern, after the TAS.

The TAS shall be either:

- a Dual Tone Alerting Signal (DT-AS); or
- a Ringing Pulse Alerting Signal (RP-AS); or
- a line reversal followed by a DT-AS (LR+DT-AS).

It will be a network operator option as to which method is used: the same method shall be used for data transmission not associated with ringing (see subclause 6.2).

In case c) at the beginning of the first ringing pattern, those polarity conditions which are pertinent during ringing will apply. Return to idle polarity, if applicable, may take place after the data transmission phase.

If the TE goes in loop state before or during the data transmission, normal incoming call procedures shall occur and the data transmission shall be aborted.

Timing

a) DT-AS

TAS (DT-AS) shall precede FSK modulation transmission by not less than 45 ms and not more than 500 ms. The application of ringing signal shall start not less than 200 ms and not more than 500 ms after FSK modulation transmission is stopped (see figure 5 and table 3). The lower limits are required to enable TE to apply and remove appropriate circuit for data reception.

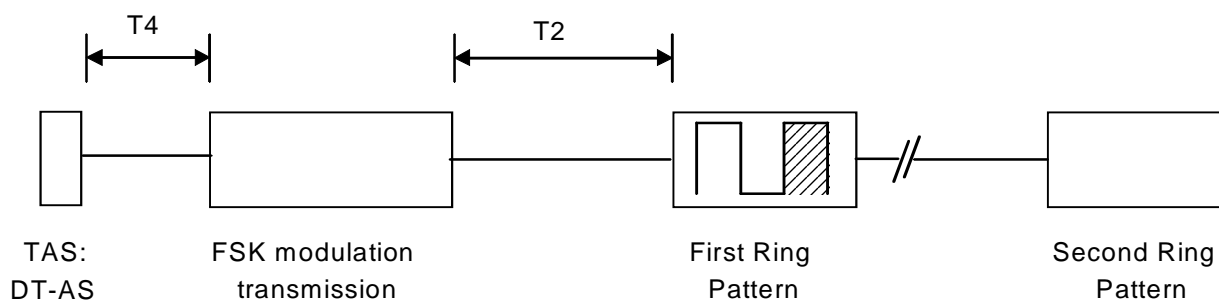
**Figure 5: Data transmission prior to ringing - case a) DT-AS****Table 3: Data transmission prior to ringing - timer values for case a)**

$45 \text{ ms} \leq T4 \leq 500 \text{ ms}$
$200 \text{ ms} \leq T2 \leq 500 \text{ ms}$

b) RP-AS

TAS (RP-AS) shall precede FSK modulation transmission by not less than 500 ms and not more than 800 ms. The application of ringing signal shall start not less than 200 ms and not more than 500 ms after FSK modulation transmission is stopped (see figure 6 and table 4). The lower limits are required to enable TE to apply and remove appropriate circuit for data reception.

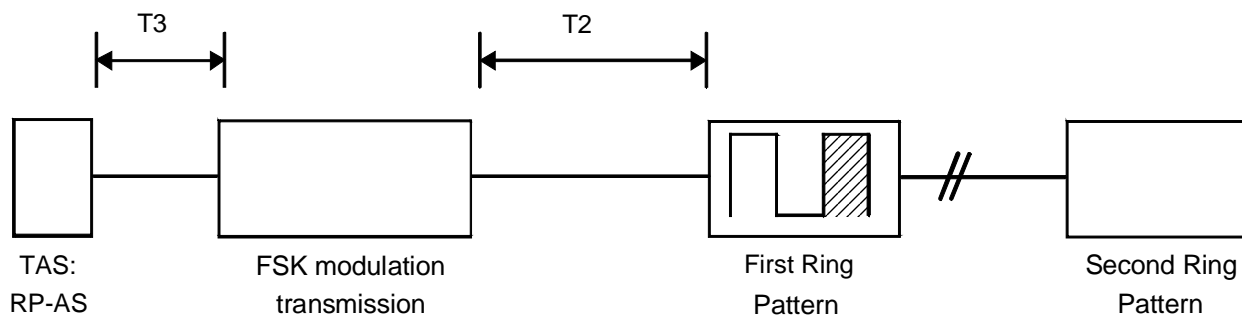

Figure 6: Data transmission prior to ringing - case b) RP-AS

Table 4: Data transmission prior to ringing - timer values for case b)

$500 \text{ ms} \leq T3 \leq 800 \text{ ms}$
$200 \text{ ms} \leq T2 \leq 500 \text{ ms}$

e) LR+DT-AS

A silent period of at least 100 ms shall immediately follow the line reversal; TAS (LR+DT-AS) shall precede FSK modulation transmission by not less than 45 ms; the total period between line reversal and the start of FSK modulation transmission shall not be greater than 700 ms. The application of ringing signal shall start not less than 200 ms and not more than 500 ms after FSK modulation transmission is stopped (see figure 7 and table 5). The lower limits are required to enable TE to apply and remove appropriate circuit for data reception.

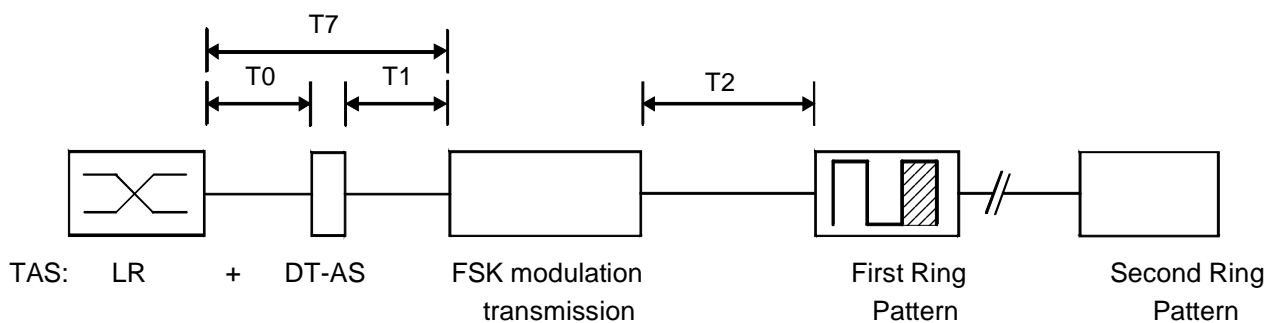

Figure 7: Data transmission prior to ringing - case c) LR+DT-AS

Table 5: Data transmission prior to ringing - timer values for case c)

$T7 \leq 700 \text{ ms}$
$T0 \geq 100 \text{ ms}$
$T1 \geq 45 \text{ ms}$
$200 \text{ ms} \leq T2 \leq 500 \text{ ms}$

6.2 Data transmission not associated with ringing

A TAS will be used to signal to the TE that data transmission is to be expected.

Data transmission shall occur after the TAS.

The TAS shall be either:

- a DT-AS; or
- a RP-AS; or
- a LR+DT-AS.

It is a network operator option as to which method is being used; nevertheless, it shall be the same method as used for data transmission associated with ringing (see subclause 6.1.2), in case a network operator uses a prior to ringing method for it.

If it is necessary a network operator using option c) (line reversal followed by DT-AS) may apply option a) (DT-AS only) to some subscribers in order to avoid unacceptable bell tinkle.

If the TE goes in loop state before or during the FSK modulation, the FSK modulation shall be aborted and normal outgoing call procedure shall occur.

Timing

a) DT-AS

TAS (DT-AS) shall precede FSK modulation transmission by not less than 45 ms and not more than 500 ms. The LE shall re-establish the condition existing before the TAS is sent within a minimum of 200 ms and a maximum of 500 ms after FSK modulation transmission is stopped (see figure 8 and table 6).The lower limit is required to enable TE to apply and remove appropriate circuit for data reception.

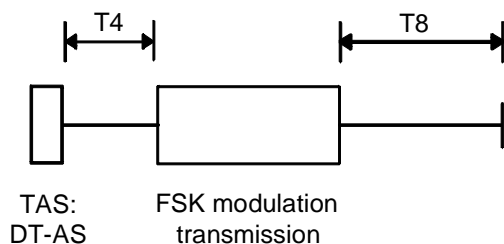

Figure 8: Data transmission not associated with ringing - case a) DT-AS

Table 6: Data transmission not associated with ringing - timer values for case a)

$45\text{ ms} \leq T4 \leq 500\text{ ms}$
$200\text{ ms} \leq T8 \leq 500\text{ ms}$

b) RP-AS

TAS (RP-AS) shall precede FSK modulation transmission by not less than 500 ms and not more than 800 ms. The LE shall re-establish the condition existing before the TAS is sent within a minimum of 200 ms and a maximum of 500 ms after FSK modulation transmission is stopped (see figure 9 and table 7).The lower limit is required to enable TE to apply and remove appropriate circuit for data reception.

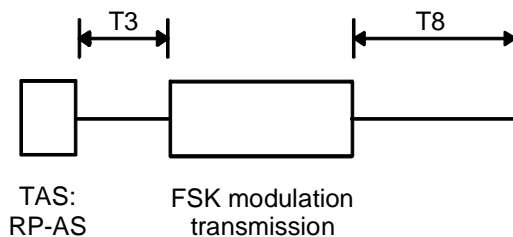

Figure 9: Data transmission not associated with ringing - case b) RP-AS

Table 7: Data transmission not associated with ringing - timer values for case b)

$500\text{ ms} \leq T3 \leq 800\text{ ms}$
$200\text{ ms} \leq T8 \leq 500\text{ ms}$

c) Line reversal followed by DT-AS

A silent period of at least 100 ms shall follow the line reversal; TAS (Line reversal followed by DT-AS) shall precede FSK modulation transmission by not less than 45 ms; the total period between line reversal and the start of FSK modulation transmission shall not be greater than 700 ms. The LE shall re-establish the condition existing before the TAS was sent within a minimum of 200 ms and a maximum of 500 ms after FSK modulation transmission is stopped (see figure 10 and table 8). The lower limits are required to enable TE to apply and remove appropriate circuit for data reception.

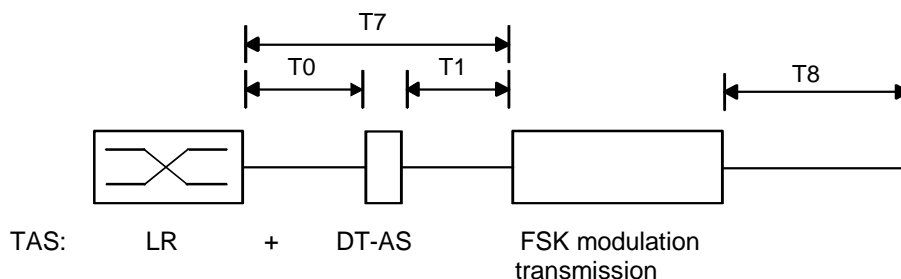

Figure 10: Data transmission not related with ringing - case c) line reversal + DT-AS

Table 8: Data transmission not related with ringing - timer values for case c)

$T7 \leq 700$ ms
$T0 \geq 100$ ms
$T1 \geq 45$ ms
200 ms $\leq T8 \leq 500$ ms

6.3 TAS physical characteristics

6.3.1 DT-AS

The physical characteristics of the DT-AS are described in table 9.

Table 9: DT-AS

Nominal Frequencies	2 130 Hz and 2 750 Hz \pm 0,5 %
Signal Level	-16,0 dBV/tone \pm 3,5 dB at the interface point Z, when the interface is terminated with the reference impedance Z_R as defined in TR 101 182 [1].
Maximum difference in the power between tones	3,0 dB
Signal Purity	Total voltage level of all extraneous signals in the band 300-3 400 Hz at the interface point Z shall be at least 30 dB lower than the level of the signal fundamental frequency.
Source impedance	Network specific.
Duration	100 ms \pm 10 ms
NOTE: The level requirement is intended to take account of signal levels of existing interfaces.	

6.3.2 RP-AS

The duration of RP-AS is described in table 10.

Table 10: RP-AS

Duration	200 ms \leq RP-AS ≤ 300 ms
----------	-------------------------------------

Annex A (normative): TE connected to the LE via a pair gain system - considerations for the Z' interface

Where pair gain system is introduced into the local distribution network, extra signalling delays are likely to result. This annex indicates the changes that might need to be made in order to support TE compatible with the main body of the present document.

- 1) Where TAS=DT-AS is used, the LE may be required to provide a line reversal, to cause the pair gain system to switch through the speech path;
- 2) In implementing the timings in the LE for interface Z in annex C, allowance may need to be made for signalling delays introduced, as follows:
 - a) the value of the timer T5, should be chosen to ensure a minimum interval of a 500 ms between first ring pattern and FSK data transmission, at interface Z';
 - b) the value of the timer T3 (in subclause 6.1.2 case b and subclause 6.2 case b) should be chosen to have a value to ensure a minimum interval of a 500 ms between RP-AS and FSK data transmission, at interface Z';
 - c) the value of the timer T0 (in subclause 6.1.2 case c) and subclause 6.2 case c) should be chosen (it may need to be up to 500 ms) to guarantee a minimum interval of 100 ms between LR and DT-AS at interface Z'.

NOTE: In case of using access networks or pair gain systems, the duration of RP-AS (subclause 6.3.2) may be extended up to 450 ms.

Annex B (normative): DTMF based subscriber line protocol

B.1 Introduction

This annex specifies the DTMF based subscriber line protocol for the support of PSTN display services at the TE. For the transfer of display information over analogue subscriber lines, use is made of the 16 code DTMF signalling system in accordance with ES 201 235 [3]. Except for these special display procedures, the normal signalling procedures and physical properties for analogue subscriber lines apply.

B.2 Line seizure phase

In case of an incoming call to a subscriber, the exchange shall seize the corresponding subscriber line for the terminating call. The line seizure may or may not be indicated to the subscriber line by means of a polarity reversal.

NOTE: Return to idle polarity, if applicable, may take place after the information transfer phase.

B.3 Alerting phase

When data transmission prior to ringing is used the first ring pattern shall be sent only after completion of the transmission of the display information.

When data transmission during ringing is used, the codes shall be sent during the first long silent period between the first and the second ring patterns.

Further the normal basic call signalling procedures shall apply.

B.4 Information transfer phase

Information transfer shall take place in association with ringing. Two methods are possible:

- data transmission prior to ringing;
- data transmission during ringing.

The sending of display information depends on the subscription option between user and network operator. The information shall be transmitted by the LE over the seized line to the TE using the DTMF codes, according to ES 201 235 [3], as specified below. The LE shall start sending within a predefined time range, not defined here, after line seizure. If the call is answered during transmission of the display information, the call shall be regarded, by the LE, as being answered and the LE shall then stop any DTMF transmission and through-connect the call.

The start code for calling number shall be either DTMF "A" or "D".

The start code for redirecting number shall be DTMF "D".

The start code for information values shall be DTMF "B".

The information may be sent in any order and shall always end with DTMF "C".

Below are shown some examples of how the transfer of information may look.

<S₁>...<S_n> represent DTMF digits (0 - 9)

EXAMPLE 1: Transfer of Calling Line Identity (CLI)

<D><S₁>...<S_n><C>

The <D> could be substituted by <A>

EXAMPLE 2: Transfer of Calling Line Identity, redirecting number and/or information values

<A><S₁>...<S_n><D><S₁>...<S_n><S₁>...<S_n><C>

The sending of information value(s) is optional

EXAMPLE 3: Transfer of information values for special events

<S₁>...<S_n><C>

The coding of S₁ and S₂ may be as follows (when using only 2 digits):

00	Number unavailable
01	Private number (restricted)

B.5 Tests

There are no tests specified and the conformance to the requirements in Annex B shall be by supplier's declaration.

Annex C (informative): Reference configurations

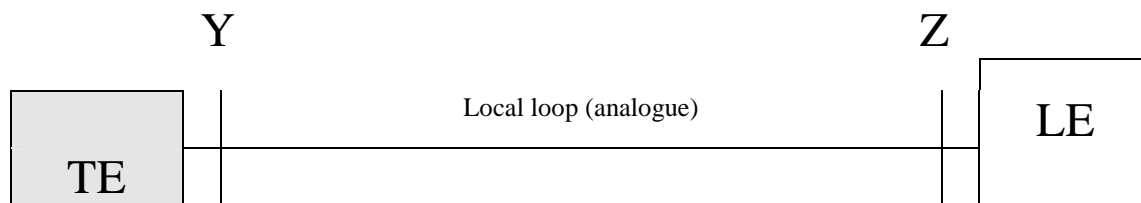
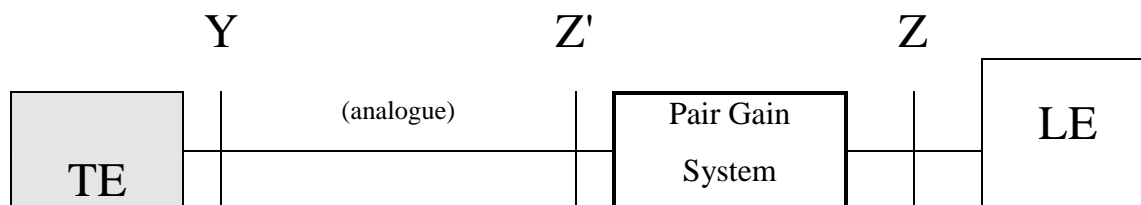

Figure C.1: TE directly connected to the LE



Pair Gain System: A multiplex or concentrating transmission system which presents normal analogue PSTN line interfaces at each end, i.e. at both Z and Z'.

Figure C.2: TE connected to the LE via a Pair Gain System

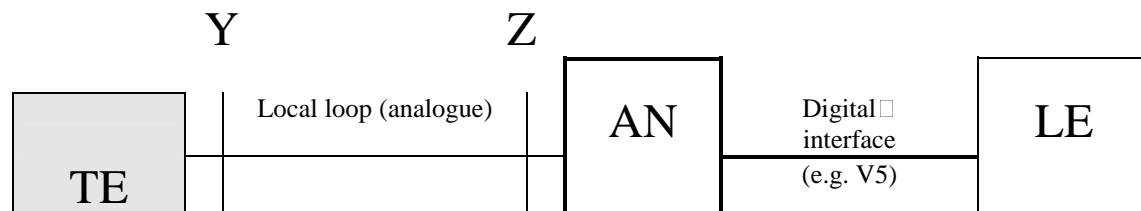

Figure C.3: TE connected to the LE via an AN

NOTE: It is recommended to present the Y interface with Z' as defined in TBR 21.

Annex D (informative): Data transmission format

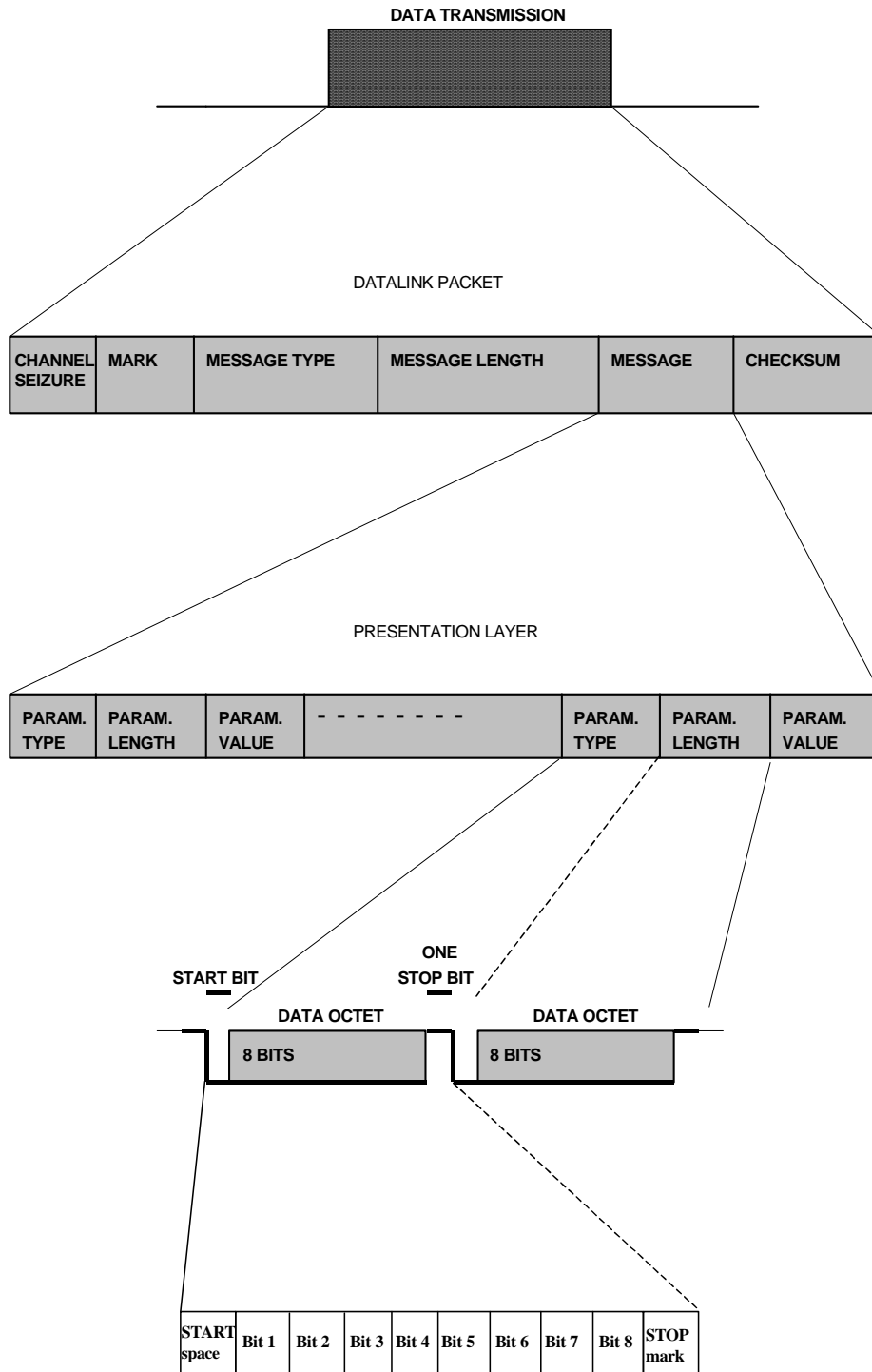

Figure D.1: Format of the data transmission

Bibliography

- Bellcore GR-30-Core (1994): "LSSGR: Voiceband Data Transmission Interface". Section 6.6.
- ETSI TBR 21: "Terminal Equipment (TE); Attachment requirements for pan-European approval for connection to the analogue Public Switched Telephone Networks (PSTNs) of TE (excluding TE supporting the voice telephony service) in which network addressing, if provided, is by means of Dual Tone Multi Frequency (DTMF) signalling".

History

Document history			
Edition 1	February 1997	Publication as ETS 300 659-1	
V1.2.1	December 1999 April 2000	One-step Approval Procedure Withdrawn from OAP	OAP 200017: 1999-12-29 to 2000-04-28
V1.3.1	September 2000	One-step Approval Procedure	OAP 20010112: 2000-09-13 to 2001-01-12